



MODEL NUMBERS:

UH15B045, UH15B070, UH15B096,
UH15B120, UH15B145, UH15B175,
UH15B195, UH15B245, UH15B295

UH15B SERIES

Cast Iron Gas Fired Boilers
For Forced Hot Water

INSTALLATION, OPERATION & MAINTENANCE MANUAL

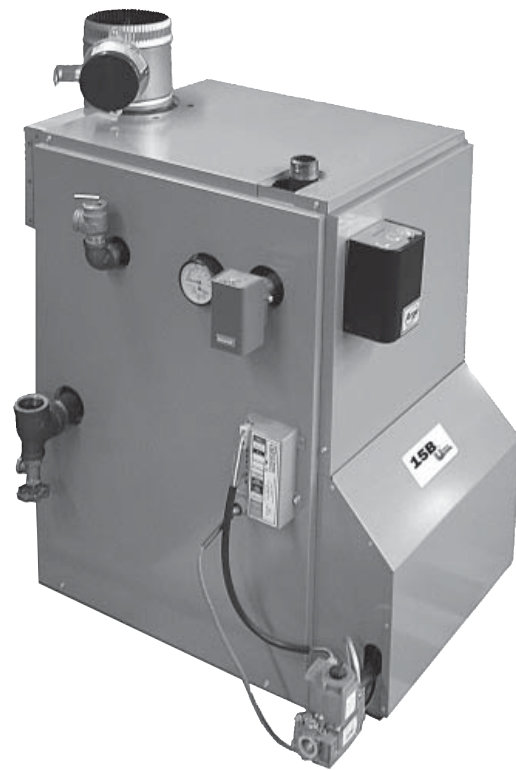

An ISO 9001-2008 Certified Company

UTICA HEATING

2201 Dwyer Avenue, Utica NY 13501
web site: www.ecrinternational.com

P/N 1305026UH, Rev. F [08/2011]

INSTALLATION MANUAL AND OPERATING INSTRUCTIONS

TABLE OF CONTENTS

Ratings & Data - Natural Gas & Propane Gas ...	3
Installation Procedure.....	4
Ventilation & Combustion Air	5
Connecting Supply & Return Piping.....	6
Vent Installation	11
Vent System Modification	11
Vent Damper Installation & Instructions.....	12
Connecting Gas Service.....	13
Electrical Section.....	13
Wiring Diagram.....	14
Lighting Instructions.....	18
Normal Sequence of Operation	20
General Instructions	20
Checking Gas Input Rate To Boiler	22
Replacement Parts.....	23
Conversion Kits	29

KEEP MANUAL NEAR BOILER

RETAIN FOR FUTURE REFERENCE

SAFETY SYMBOLS & WARNINGS

The following defined symbols are used throughout this manual to notify the reader of potential hazards of varying risk levels.

	DANGER
	Indicates a hazardous situation which, if not avoided, WILL result in death, serious injury.

	WARNING
	Indicates a hazardous situation which, if not avoided, may result in death, serious injury.

	CAUTION
	Indicates a hazardous situation which, if not avoided, may result in injury.

	NOTICE
	Indicates information which should be followed to ensure proper installation and operation.

IMPORTANT: Read the following instructions COMPLETELY before installing!!

	WARNING
	Keep boiler area clear and free from combustible materials, gasoline and other flammable vapors and liquids. Do not obstruct air openings to the boiler room. Modification, substitution or elimination of factory equipped, supplied or specified components may result in, personal injury or loss of life. To the owner - installation and service of this boiler must be performed by a qualified installer. To the installer - leave all instructions with the boiler for future reference. When this product is installed in the Commonwealth of Massachusetts installation must be performed by a licensed plumber or licensed gas fitter.

	WARNING
	All installations of boilers and venting should be done only by a qualified expert and in accordance with the appropriate manual. Installing or venting a boiler or any other gas appliance with improper methods or materials may result in serious injury or death due to fire or to asphyxiation from poisonous gases such as carbon monoxide which is odorless and invisible.



C.S.A. Certified
For Natural Gas Or Propane

Tested For 100 psi
ASME
Working Pressure

RATINGS & DATA - NATURAL GAS & PROPANE GAS

 Model No.	Input Mbh ⁽¹⁾	Heating Capacity Mbh ⁽¹⁾	Net I=B=R Rating Water Mbh ^{(1) **}	AFUE Elect. Ign.	AFUE Stdg. Pilot	No. Of Burners	Recommended Air Cushion Tank ⁽³⁾	Water Content (Gals.)
15B045	45	37	32	82.0%	80.0%	1	15	2.4
15B070	70	57	50	82.0%	80.0%	2	15	4.0
15B096	96	79	69	82.0%	80.0%	2	30	4.0
15B120	120	98	85	82.0%	80.0%	3	30	5.6
15B145	145	119	103	82.0%	80.0%	3	30	5.6
15B175	175	141	123	80.5%	80.0%	4	30	7.2
15B195	195	157	137	80.5%	80.0%	4	30	7.2
15B245	245	197	171	80.5%	80.0%	5	30	8.8
15B295	295	237	206	80.5%	80.0%	6	60	10.4

EXPLANATORY NOTES

- All boilers are design certified for installation on noncombustible floor.
- For installation on combustible floors use combustible floor kit.
- Recommended chimney height 20 feet. In special cases where conditions permit, chimney height may be reduced to 10 feet. Refer to the latest revision of NFCC.
- Electric service to be 120 Volts, 15 Amps, 60 Hz.
- The MEA number for the this boiler is 39-86-E Vol VIII.
- (1) For elevations above 2000 feet, ratings should be reduced at a rate of 4% for each 1000 feet above sea level.
- (2) Base on 170° temperature in radiators.
- (3) Tank sized for non-ferrous baseboard or radiant panel systems. Increase size for cast iron baseboard and radiation.
- Net I=B=R Water Ratings based on a pickup allowance of 1.15. Consult manufacturer before selecting boiler for installations having unusual piping and pickup requirements, such as intermittent system operation, extensive piping systems, etc..

STANDARD EQUIPMENT: Boiler Jacket, Cast Iron Boiler Battery, High Limit Control, Vent Damper Relay, Temperature - Pressure Gauge, Circulator With Return Piping To Boiler, Main Gas Burners, Combination 24 Volt Gas Control (Includes Automatic Gas Valve, Gas Pressure Regulator, Automatic Pilot, Safety Shutoff, Pilot Flow Adjustment, Pilot Filter), A.S.M.E. Relief Valve, Drain Valve, Spill Switch, Rollout Switch, Automatic Vent Damper. Not Shown Are: Wiring Harness, Thermocouple, Non-linting Safety Pilot.

OPTIONAL EQUIPMENT: Intermittent Electric Ignition Pilot System.

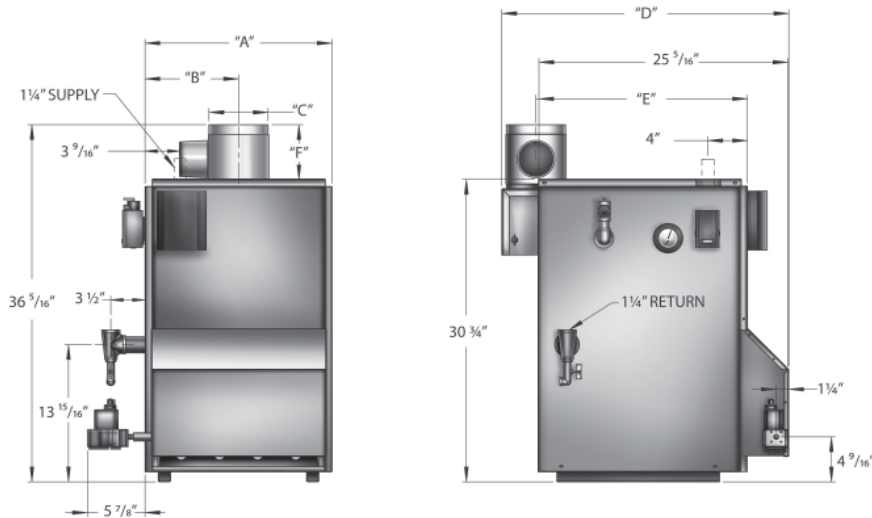

Model No.	Natural Gas Inlet*	Dimensions (Inches)						Pump Size Supply & Return Tappings
		A	B	C	D	E	F	
15B045	1/2"	11 1/4	5 5/8	4	27 1/8	20 7/16	4 15/16	1 1/4"
15B070	1/2"	15 1/8	7	5	28 1/8	20 15/16	4 15/16	1 1/4"
15B096	1/2"	15 1/8	7	5	28 1/8	20 15/16	4 15/16	1 1/4"
15B120	1/2"	19	9 1/2	6	29 1/8	21 7/16	5 7/16	1 1/4"
15B145	1/2"	19	9 1/2	6	29 1/8	21 7/16	5 7/16	1 1/4"
15B175	1/2"	22 7/8	11 3/16	7	30 1/8	21 15/16	5 15/16	1 1/4"
15B195	1/2"	22 7/8	11 3/16	7	30 1/8	21 15/16	5 15/16	1 1/4"
15B245	3/4"	26 3/4	13 5/16	8	31 1/8	22 7/16	6 15/16	1 1/4"
15B295	3/4"	30 5/8	15 5/16	9	32 1/8	22 15/16	8 15/16	1 1/4"

* Propane Gas Inlet (All Units) 1/2"

INSTALLATION PROCEDURE



WARNING

Improper installation, adjustment, alteration, service or maintenance can cause injury.

1. Installation must conform to requirements of authority having jurisdiction or, in the absence of such requirements, to the National Fuel Gas Code, ANSI Z223.1/NFPA 54.
2. Where required by the authority having jurisdiction, installation must conform to the Standard for Controls and Safety Devices for Automatically Fired Boilers, ANSI/ASME CSD-1.
3. Boiler series is classified as Category I. Vent installation shall be in accordance with "Venting of Equipment," of the National Fuel Gas Code, ANSI Z223.1/NFPA 54, or applicable provisions of the local building codes.
4. Boiler has met safe lighting and other performance criteria with the gas manifold and control assembly on the boiler per ANSI Z21.13/CGA 4.9.
5. Boiler shall be installed such that the gas ignition system components are protected from water (dripping, spraying, rain, etc.) during appliance operation and service, (circulator replacement, condensate trap, control replacement, etc.).
6. Locate boiler on level, solid base as near the chimney as possible and centrally located with respect to heat distribution system as practical.
7. Allow 24 inches at front and right side for servicing and cleaning.
8. When installed in utility room, door should be wide enough to allow largest boiler part to enter, or to permit replacement of another appliance such as a water heater.

9. FOR INSTALLATION ON NON-COMBUSTIBLE FLOORS ONLY - For installation on combustible flooring special base must be used. (See Replacement Parts Section.) **Boiler can not be installed on carpeting.**

10. Minimum clearances to combustible construction are:

TOP	18 in.
FRONT	ALCOVE *
FLUE CONNECTOR	6 in.
REAR	8 in.
CONTROL SIDE	9 in.
OTHER SIDE	3 in.
PIPES	1/2 in.

NOTE: Greater clearances for access should supersede fire protection clearances.

* The definition of an Alcove is a three sided space with no wall in front of the boiler. The ANSI standard for an alcove is 18 inches from the front of an appliance to the leading edge of the side walls as shown below.

Minimum Clearances To Combustible Construction (As Seen From Above)

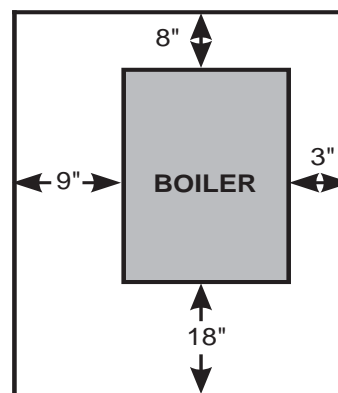

VENTILATION & COMBUSTION AIR

WARNING



Air openings to combustion area must not be obstructed. Following instructions below, adequate combustion air can be maintained.

Provide combustion air and ventilation air in accordance with the section "Air for Combustion and Ventilation," of the National Fuel Gas Code, ANSI Z223.1 / NFPA 54, or applicable provisions of local building codes.

Provide make-up air where exhaust fans, clothes dryers, and kitchen ventilation equipment interfere with proper operation.

National Fuel Gas Code recognizes several methods of obtaining adequate ventilation and combustion air. Requirements of the authority having jurisdiction may override these methods.

- **Engineered Installations.** Must be approved by authority having jurisdiction.
- **Mechanical Air Supply.** Provide minimum of 0.35 cfm per Mbh for all appliances located within space. Additional requirements where exhaust fans installed. Interlock each appliance to mechanical air supply system to prevent main burner operation when mechanical air supply system not operating.
- **All Indoor Air.** Calculate minimum volume for all appliances in space. Use a different method if minimum volume not available.
 - A. Standard Method.** Cannot be used if known air infiltration rate is less than 0.40 air changes per hour. See Table 1 for space with boiler only. Use equation for multiple appliances.

$$\text{Volume} \geq 50 \text{ ft}^3 \times \text{Total Input [Mbh]}$$

- B. Known Air Infiltration Rate.** See Table 1 for space with boiler only. Use equation for multiple appliances. Do not use an air infiltration rate (ACH) greater than 0.60.

$$\text{Volume} \geq 21 \text{ ft}^3/\text{ACH} \times \text{Total Input [Mbh]}$$

- C. Refer to National Fuel Gas Code** for opening requirements between connected indoor spaces.
- **All Outdoor Air.** Provide permanent opening(s) communicating directly or by ducts with outdoors.
 - A. Two Permanent Opening Method.** Provide opening commencing within 12 inches of top and second opening commencing within 12 inches of bottom of enclosure.
 - Direct communication with outdoors or communicating through vertical ducts. Provide minimum free area of 1 in² per 4 Mbh of total input rating of all appliances in enclosure.
 - Communicating through horizontal ducts. Provide minimum free area of 1 in² per 2 Mbh of total input rating of all appliances in enclosure.
 - B. One Permanent Opening Method.** Provide opening commencing within 12 inches of top of enclosure. Provide minimum clearance of 1 inch on sides/back and 6 inches on front of boiler (does not supersede clearance to combustible materials).
 - C. Refer to National Fuel Gas Code** for additional requirements for louvers, grilles, screens and air ducts.
- **Combination Indoor and Outdoor Air.** Refer to National Fuel Gas Code for application information.

Table 1 - Minimum Room Volume, Indoor Air Only*

Input Mbh	Standard Method	Known Air Infiltration Rate Method (Air Changes Per Hour)					
		0.1	0.2	0.3	0.4	0.5	0.6
45	2250	9450	4725	3150	2363	1890	1575
70	3500	14700	7350	4900	3675	2940	2450
96	4800	20160	10080	6720	5040	4032	3360
120	6000	25200	12600	8400	6300	5040	4200
145	7250	30450	15225	10150	7613	6090	5075
175	8750	36750	18375	12250	9188	7350	6125
195	9750	40950	20475	13650	10238	8190	6825
245	12250	51450	25725	17150	12863	10290	8575
295	14750	61950	30975	20650	15488	12390	10325

* Table values based on boiler only. Add volume for any additional appliances.

CONNECTING SUPPLY & RETURN PIPING

Hydronic Piping - General

- Install piping in accordance with authority having jurisdiction.
- Support system piping and safety relief valve discharge piping.

Special Conditions

- System piping exposed to freezing conditions: Use inhibited propylene glycol solutions certified by fluid manufacturer for use with closed water heating system. Do not use automotive or ethylene glycol.
- Boiler installed above radiation level (or as required by authority having jurisdiction). Install low water cutoff.
- Boiler used in connection with refrigeration system. Install piping in parallel with boiler, with appropriate valves to prevent chilled medium from entering boiler. See **Figure 2**.
- System piping connected to heating coils located in air handling unit exposed to refrigerated air circulation. Install flow control valves or other automatic means to prevent gravity circulation of boiler water during cooling cycle.

Safety Relief Valve

NOTICE

Boiler rated at 100 psig maximum allowable working pressure. Boiler provided with 30 psig safety relief valve. Field source safety relief valve for system pressures greater than 30 psig. Temperature-Pressure Gauge provided with boiler is satisfactory for 30-50 psig operation. Replace Temperature-Pressure Gauge for system pressure over 50 psig. Scale on dial must be graduated to not less than 1½ nor more than 3½ time safety relief valve pressure settings.

- Install safety relief valve and air vent using pipe fittings provided with boiler. See figure on page 3.
- Install safety relief valve with spindle in vertical position.
- Do not install shutoff valve between boiler and safety relief valve.
- Systems with automatic fill valves require back flow prevention device.
- Install discharge piping from safety relief valve. See **Figure 1**.
 - Use ¾" or larger pipe.
 - Use pipe suitable for temperatures of 375°F (191°C) or greater.

- Individual boiler discharge piping shall be independent of other discharge piping.
- Size and arrange discharge piping to avoid reducing safety relief valve relieving capacity below minimum relief valve capacity stated on rating plate.
- Run pipe as short and straight as possible to location protecting user from scalding and properly drain piping.
- Install union, if used, close to safety relief valve outlet.
- Install elbow(s), if used, close to safety relief valve outlet and downstream of union (if used).
- Terminate pipe with plain end (not threaded).
- When boiler is connected to heating system utilizing multiple zoned circulators, each circulator must be supplied with flow control valve to prevent gravity circulation.
- Hot water boilers and system must be filled with water and maintained to minimum pressure of 12 p psig.
- Bypass piping is an option which gives ability to adjust the supply boiler water temperature to fit the system or condition of installation. This method of piping, however, is not typically required for baseboard heating systems. Typical installations where bypass piping is used are as follows:
 - A. This method is used to protect boilers from condensation forming due to low temperature return water. Generally noticed in large converted gravity systems or other large water volume systems. **Figure 3**.
 - B. These methods are used to protect systems using radiant panels and the material they are encased in from high temperature supply water from the boiler and protect boiler from condensation.

NOTE#1: When using bypass piping, adjust valves V1 & V2 until desired system temperature is obtained.

NOTE#2: Bypass loop must be same size piping as the supply and return piping.

- Installation using circulators and zone valves are shown in **Figures 3-8**. For further piping information refer to I=B=R Installation and Piping Guide.

WARNING



Burn and scald hazard. Safety relief valve could discharge steam or hot water during operation. Install discharge piping per these instructions.

CONNECTING SUPPLY & RETURN PIPING

WARNING

To avoid burns, scalding, or water damage due to discharge of steam and/or hot water during operation, a discharge line shall be installed to relief valve outlet connection.

Discharge line shall:

- connect to relief valve outlet and piped down to safe point of disposal. Check local codes for maximum distance from floor or allowable safe point of discharge.
- be of pipe size equal to or greater than that of the relief valve outlet over the entire length of discharge line;
- have no intervening shutoff valve between safety relief valve and discharge to atmosphere (do not plug or place any obstruction in discharge line).
- terminate freely to atmosphere where any discharge will be clearly visible and at no risk of freezing;
- allow complete drainage of the valve and the discharge line;
- be independently supported and securely anchored to avoid applied stress on the relief valve;
- be as short and straight as possible;
- terminate with plain end (not threaded);
- be constructed of material suitable for exposure to temperatures of 375° F; or greater.

Refer to local codes and appropriate ASME Boiler and Pressure Vessel Code for additional installation requirements.

Figure 1

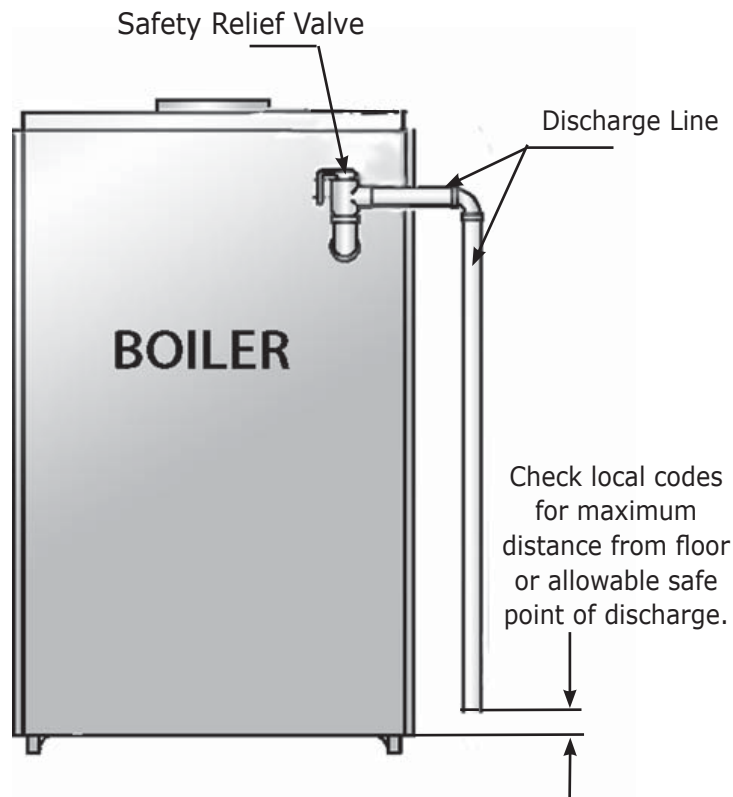

CONNECTING SUPPLY AND RETURN PIPING

IMPORTANT: Circulators in following illustrations are mounted on system supply side, but mounting on system return side is also acceptable practice.

Figure 2

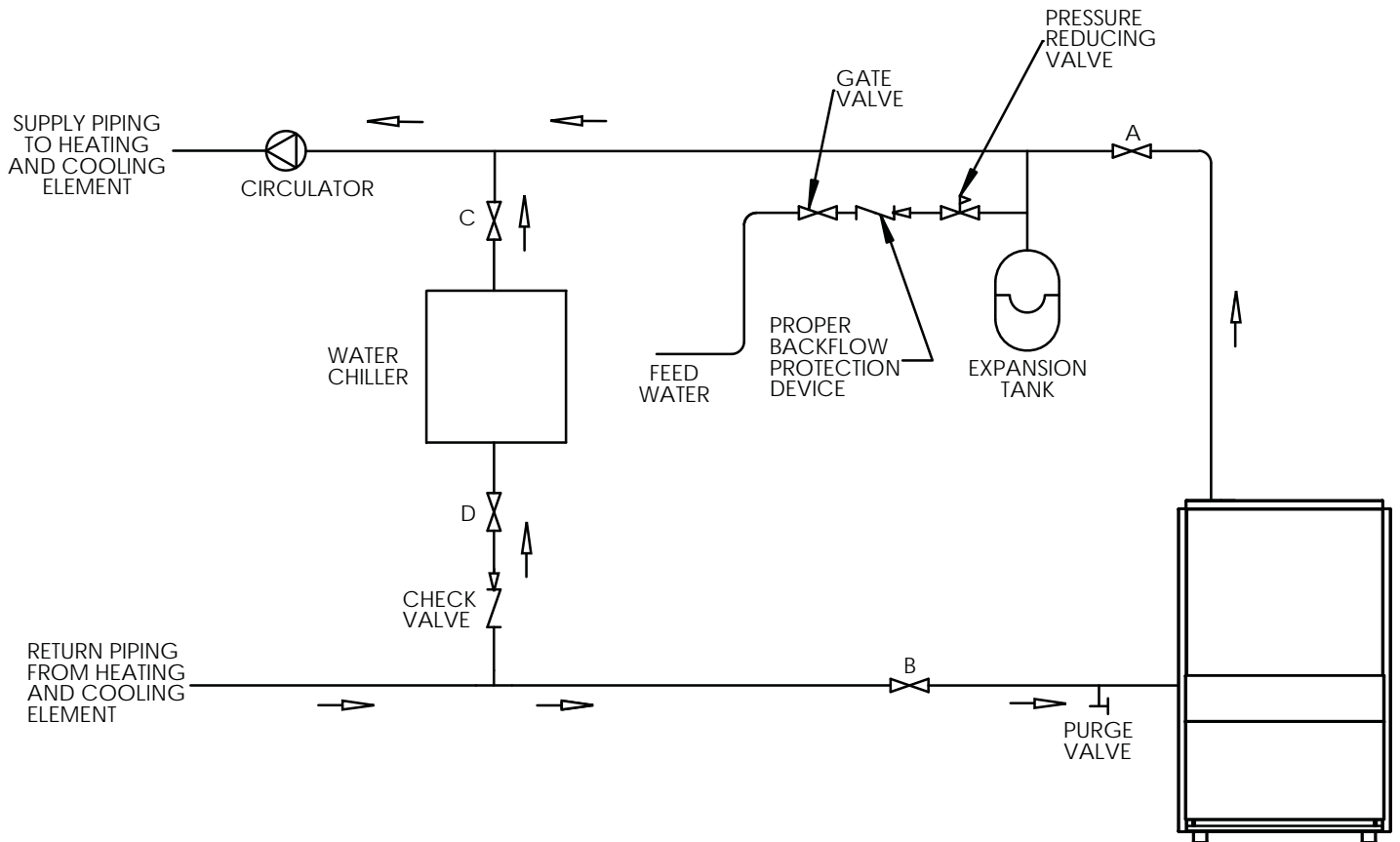

CONNECTING SUPPLY AND RETURN PIPING

Figure 3 - BYPASS PIPING - AUTOMATIC MIXING VALVE

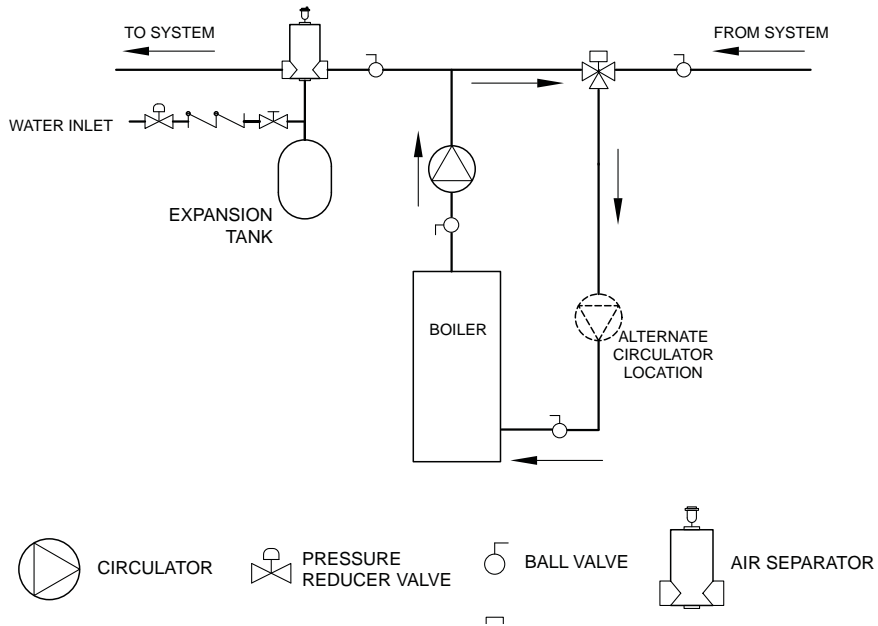
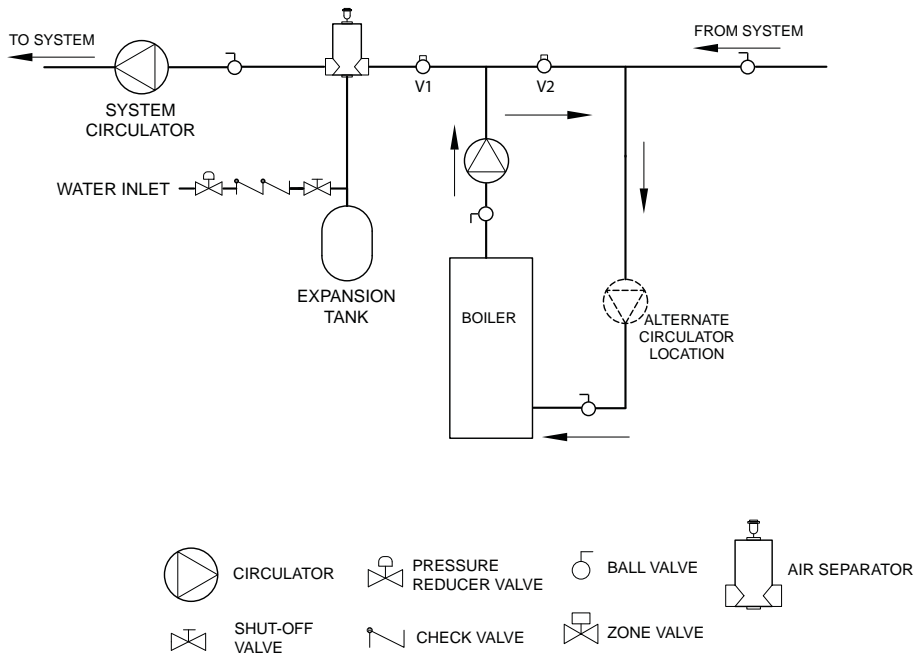

Figure 4 - BYPASS PIPING - FIXED LOW TEMP ONLY



CONNECTING SUPPLY AND RETURN PIPING

Figure 5 - Single Zone System With DHW Priority

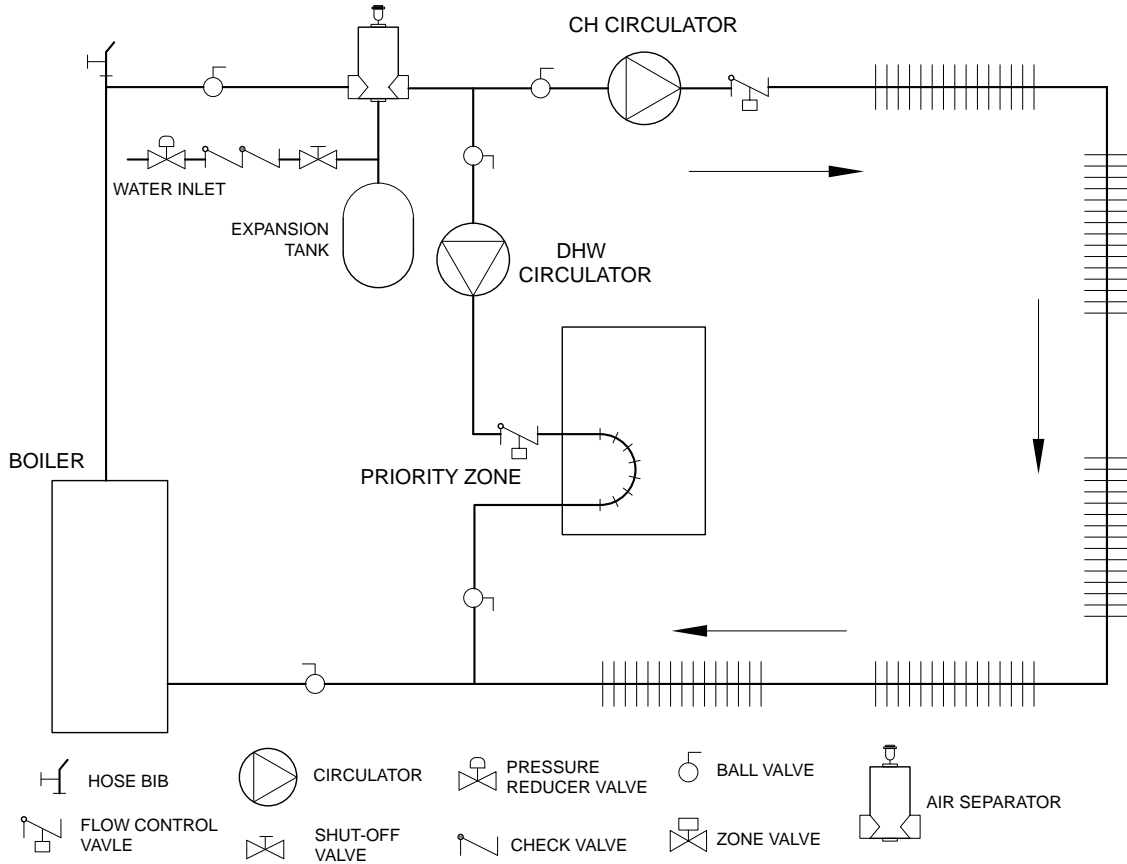
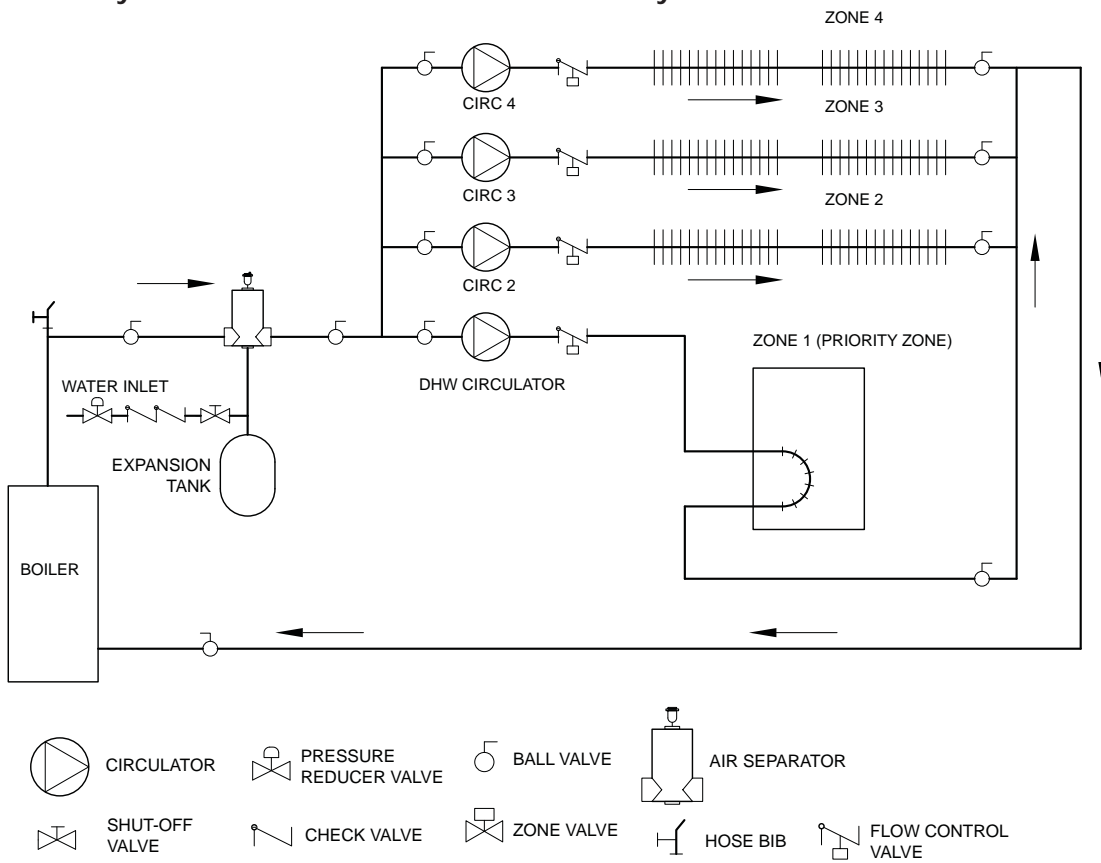

Figure 6 - Multi-zone System with Circulators and DHW Priority



CONNECTING SUPPLY AND RETURN PIPING

Figure 7 - Multi-zone System With Zone Valves And DHW Priority (With Circulator)

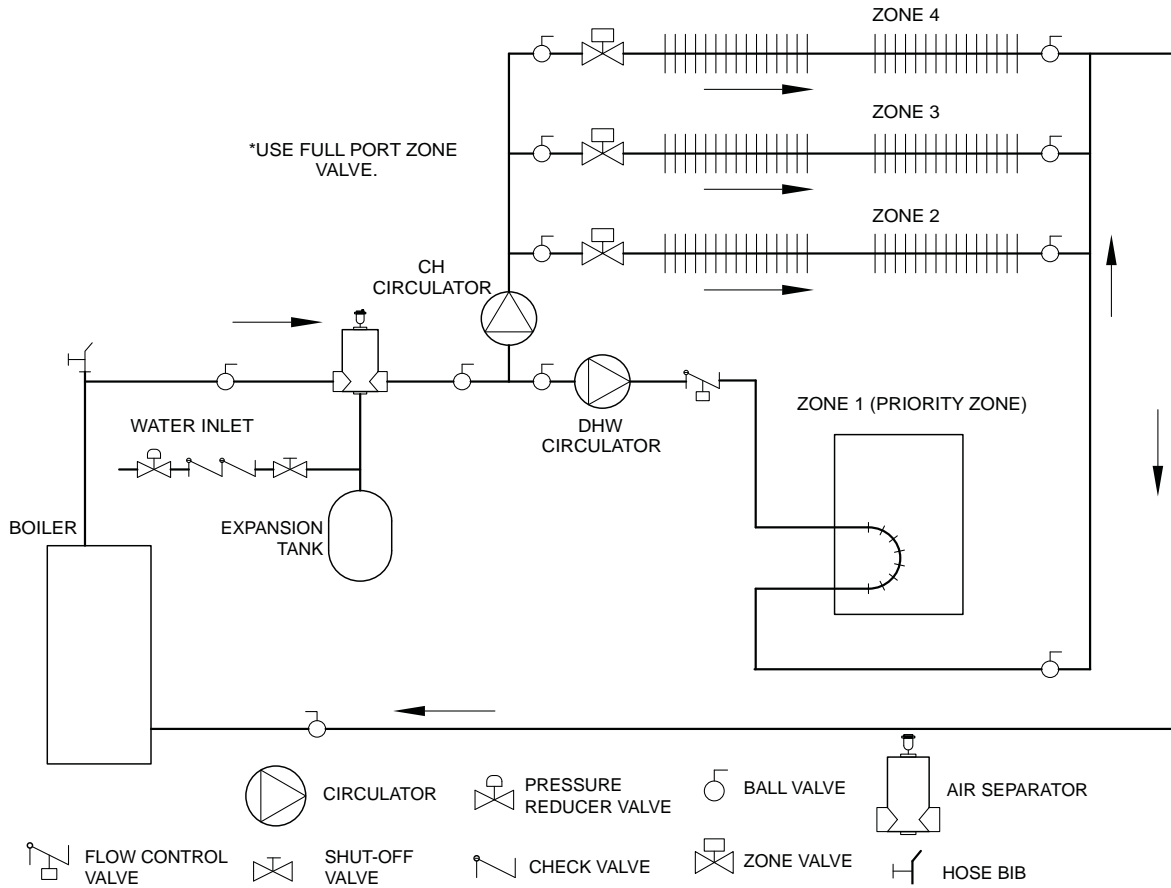
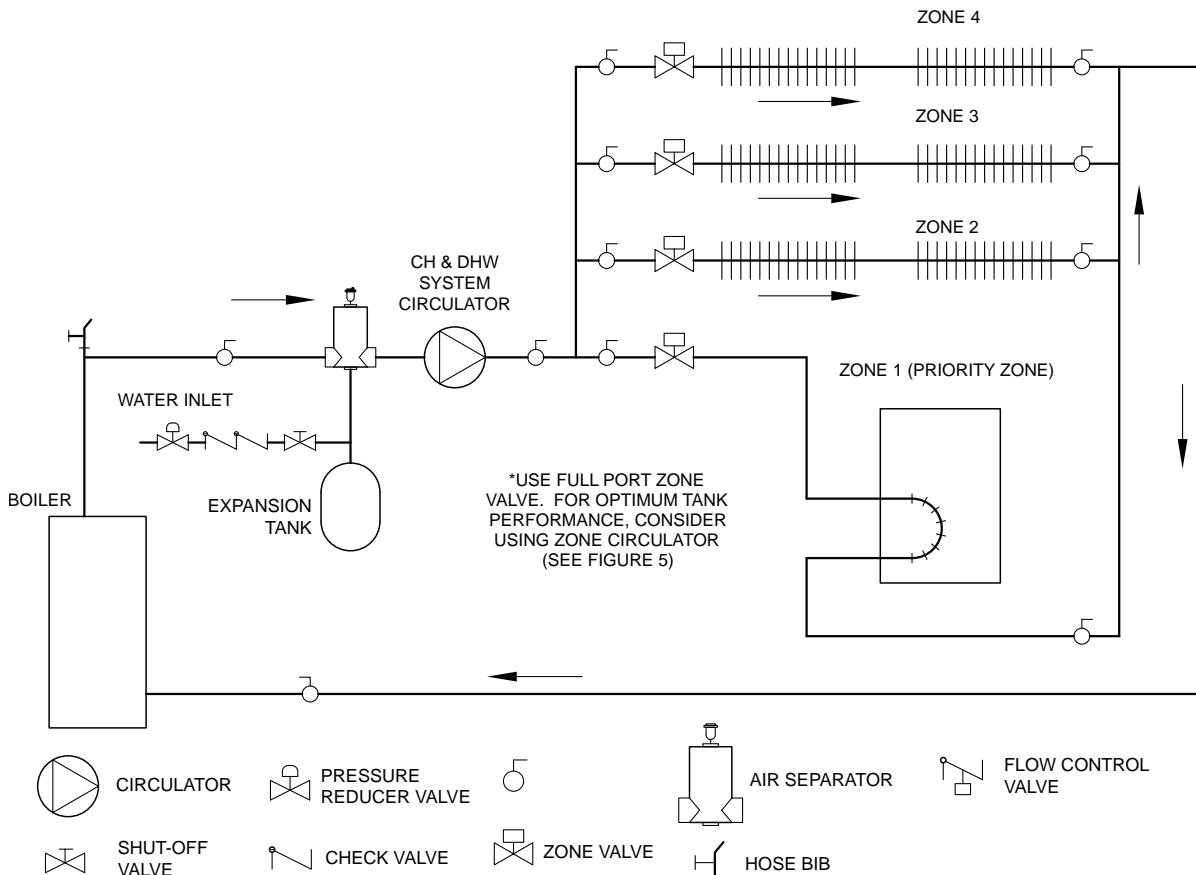

Figure 8 - Multi-zone System With Zone Valves And DHW Priority (With Zone Valve)



VENT INSTALLATION

WARNING



All installations of boilers and venting should be done only by a qualified expert and in accordance with the appropriate manual. Installing or venting a boiler or any other gas appliance with improper methods or materials may result in serious injury or death due to fire or to asphyxiation from poisonous gases such as carbon monoxide which is odorless and invisible.

1. Vent pipe must slope upward from boiler not less than 1/4 inch per 1 foot to the vent terminal.
2. Horizontal portions of venting system shall be supported rigidly every 5 feet and at elbows. No portion of vent pipe should have any dips or sags.
3. This boiler series is classified as Category I. Vent installation shall be in accordance with "Venting of Equipment," of the National Fuel Gas Code, ANSI Z223.1/NFPA 54, or applicable provisions of the local building codes.
4. Vent connectors serving appliances vented by natural draft shall not be connected into any portion of mechanical draft systems operating under positive pressure.
5. Connect flue pipe from draft hood to chimney. Bolt or screw joints together to avoid sags. Flue pipe should not extend beyond inside wall of chimney. Do not install manual damper in flue pipe or reduce size of flue outlet except as provided by the latest revision of ANSI Z223.1. Protect combustible ceiling and walls near flue pipe with fireproof insulation. Where two or more appliances vent into a common flue, the area of the common flue must be at least equal to the area of the largest flue plus 50 percent of the area of each additional flue.

VENT SYSTEM MODIFICATION

When existing boiler is removed from a common venting system, the system is likely to be too large for the proper venting of the appliances still connected to it.

REMOVAL OF BOILER FROM VENTING SYSTEM

At the time of removal of an existing boiler, the following steps shall be followed with each appliance remaining connected to the common venting system placed in operation, while the other appliances remaining connected to the common venting system are not in operation.

1. Seal any unused opening in the common venting system.
2. Visually inspect the venting system for proper size and horizontal pitch and determine there is no blockage or restriction, leakage, corrosion and other deficiencies which could cause an unsafe condition.
3. Insofar as is practical, close all building doors and windows and all doors between the space in which the appliances remaining connected to the common venting system are located and other spaces of the building. Turn on clothes dryers and any other appliance not connected to the common venting system. Turn on any exhaust fans, such as range hoods and bathroom exhausts, so they operate at maximum speed. Do not operate a summer exhaust fan. Close fireplace dampers.
4. Place in operation the appliance being inspected. Follow the lighting instructions. Adjust thermostat so appliance will operate continuously.
5. Test for spillage at the draft hood relief opening after 5 minutes of main burner operation. Use the flame of a match or candle, or smoke from a cigarette, cigar or pipe.
6. After it has been determined that each appliance remaining connected to a common venting system properly vents when tested as outlined above, return doors, windows, exhaust fans, fireplace dampers and any other gas burning appliances to their previous condition of use.
7. Any improper operation of the common venting system should be corrected so the installation conforms with the National Fuel Gas Code, ANSI Z223.1/NFPA 54. When re-sizing any portion of the common venting system, the common venting system should be re-sized to approach the minimum size as determined using the appropriate tables in Chapter 13 of the National Fuel Gas Code, ANSI Z223.1/NFPA 54.

VENT DAMPER INSTALLATION & INSTRUCTIONS

Figure 9 - DAMPER INSTALLATION

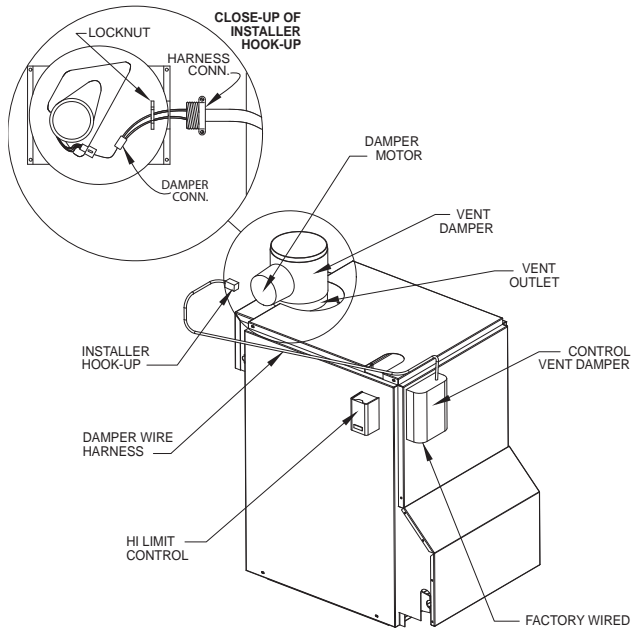
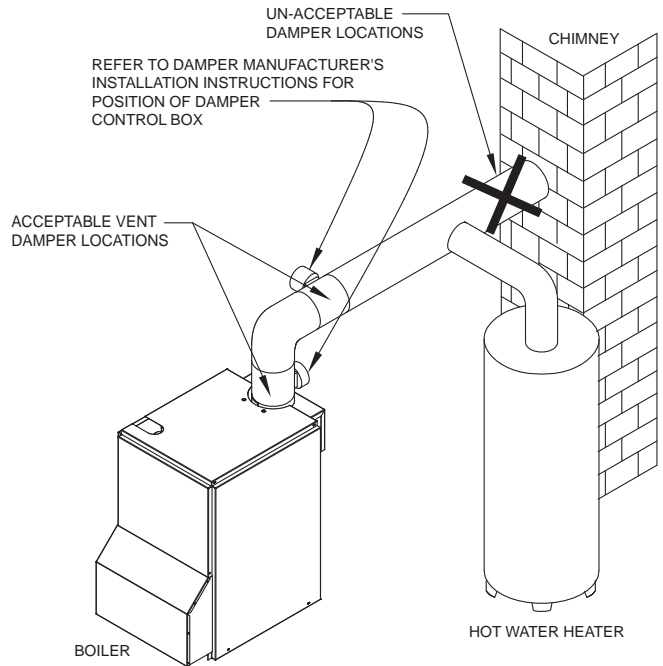

Figure 10 - DAMPER LOCATION



NOTE: Refer to **Figure 9** for steps 1-6.

1. Place Vent Damper on or as close to vent outlet of boiler as possible. **Figure 9**. Do not modify draft hood or vent damper during installation.
2. Remove Vent Damper Motor cover.
3. Feed damper wire harness connector through bracket hole on Damper Motor frame.
4. Tighten locknut onto Damper wire harness connector.
5. Plug Damper connector into socket on Damper Motor frame.
6. Replace Damper Motor cover and wire Damper in accordance with **Figure 9**.

1. Ensure only boiler is serviced by Vent Damper. **Figure 10**.
2. Clearance of not less than 6 inches between Vent Damper and combustible material must be maintained. Additional clearance should be allowed for service of Vent Damper.
3. Vent Damper must be in open position when appliance main burners are operating.
4. Vent Damper position indicator must be in visible location following installation.
5. Thermostat's heat anticipator must be adjusted to match total current draw of all controls associated with boiler during heating cycle.

CONNECTING GAS SERVICE

1. Use piping materials and joining methods acceptable to authority having jurisdiction. In absence of such requirements:
 - National Fuel Gas Code, ANSI Z223.1/NFPA 54

Ground joint union should be installed for easy removal of gas control for servicing. Drip leg or trap must be installed at bottom of vertical section of piping at inlet to boiler. Pipe compound resistant to action of liquefied petroleum gases must be used on all threaded pipe connections. Check with local utility for location of manual shutoff valve if required.

Figure 11.

2. Gas line should be of adequate size to prevent undue pressure drop and never smaller than pipe size of main gas control valve. See Chart below.
3. Boiler and its gas connection must be leak tested before placing boiler in operation.
4. Boiler and its individual shutoff valve must be disconnected from gas supply piping system during any pressure testing of that system at test pressures in excess of 1/2 psi (3.5 kPa).
Boiler must be isolated from gas supply piping system by closing its individual manual shutoff valve during any pressure testing of gas supply piping system at test pressures equal to or less than 1/2 psi (3.5 kPa).

	Natural Gas	Propane
Min. Supply Pressure	5.0" w.c.	11.0" w.c.
Max. Supply Pressure	13.5" w.c.	13.5" w.c.
Manifold Pressure	3.5" w.c.	10.5" w.c.



WARNING

Do not use an open flame.

Figure 11

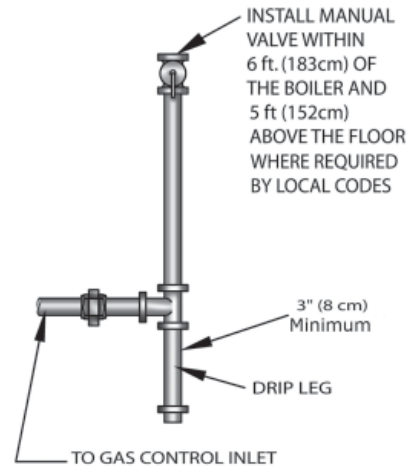

Maximum Capacity Of Pipe In Cubic Feet Of Gas/Hour
(Gas Pressure = 0.5 psig or less, Pressure Drop = 5 in. w/c)

Length of Pipe (Feet)	Nominal Iron Pipe Size			
	1/2"	3/4"	1"	1 1/4"
10	175	360	680	1400
20	120	250	465	950
30	97	200	375	770
40	82	170	320	660
60	66	138	260	530
80	57	118	220	460
100	50	103	195	400

For additional information refer to the National Fuel Gas Code Handbook.

ELECTRICAL SECTION

ELECTRICAL WIRING

See wiring diagrams on the following four pages for details.

Boiler must be electrically bonded to ground in accordance with the requirements of the authority having jurisdiction or, in the absence of such requirements, with the National Electrical Code, ANSI/NFPA 70.

IMPORTANT: Install fused disconnect switch between boiler and electrical panel at convenient location.

THERMOSTAT INSTALLATION

1. Thermostat should be installed on inside wall about four feet above floor.
2. NEVER install thermostat on outside wall.
3. Do not install thermostat where it will be affected by drafts, hot or cold pipes, sunlight, lighting fixtures, televisions, a fireplace, or chimney.
4. Check thermostat operation by raising and lowering thermostat setting as required to start and stop burners.
5. Instructions for final adjustment of thermostat are packaged with thermostat (adjusting heating anticipator, calibration, etc.)

WIRING DIAGRAM

Figure 13 - 24V Intermittent Ignition

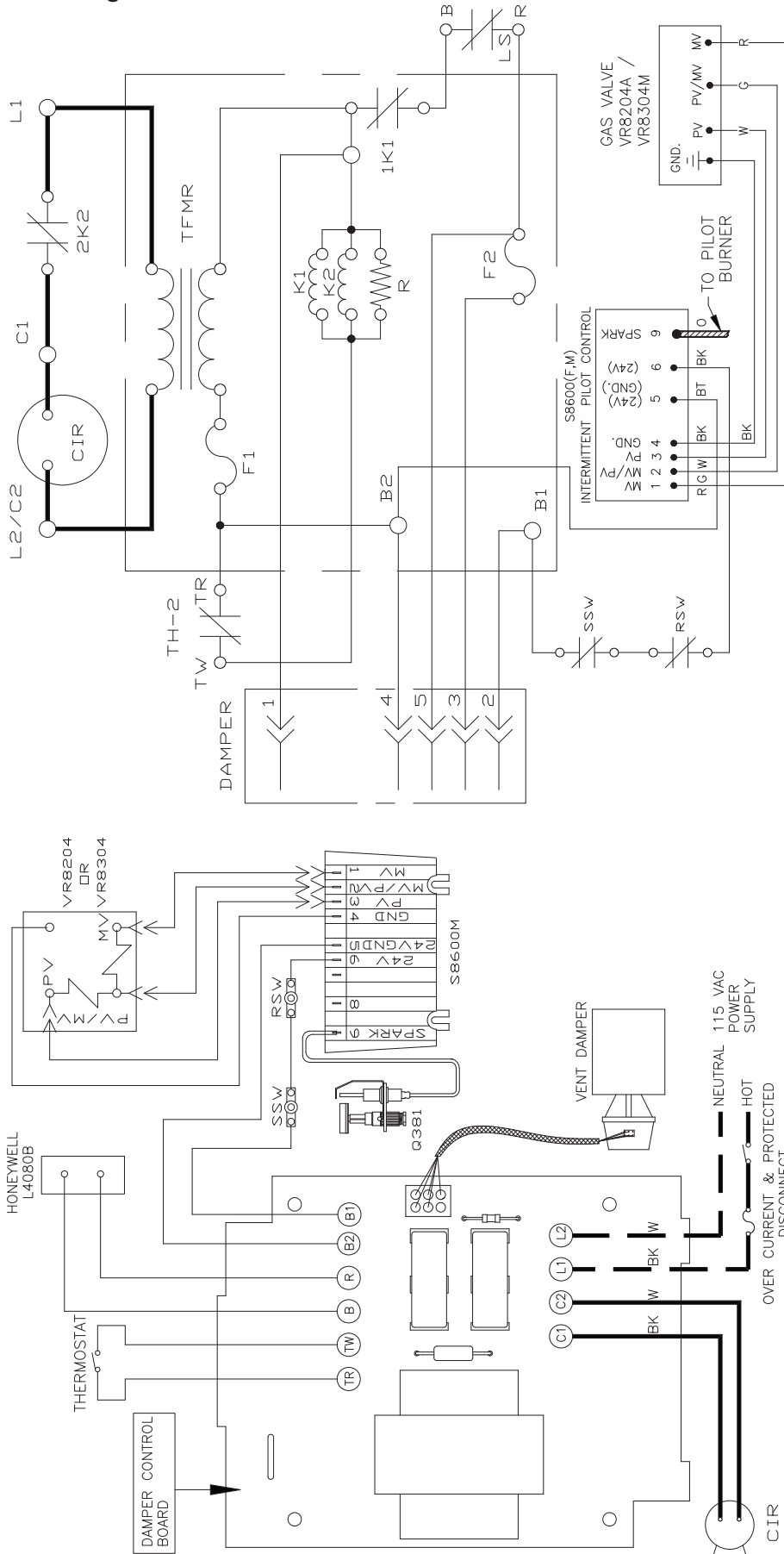

WIRING DIAGRAM

Figure 14 - 24V Standing Pilot with LWCO

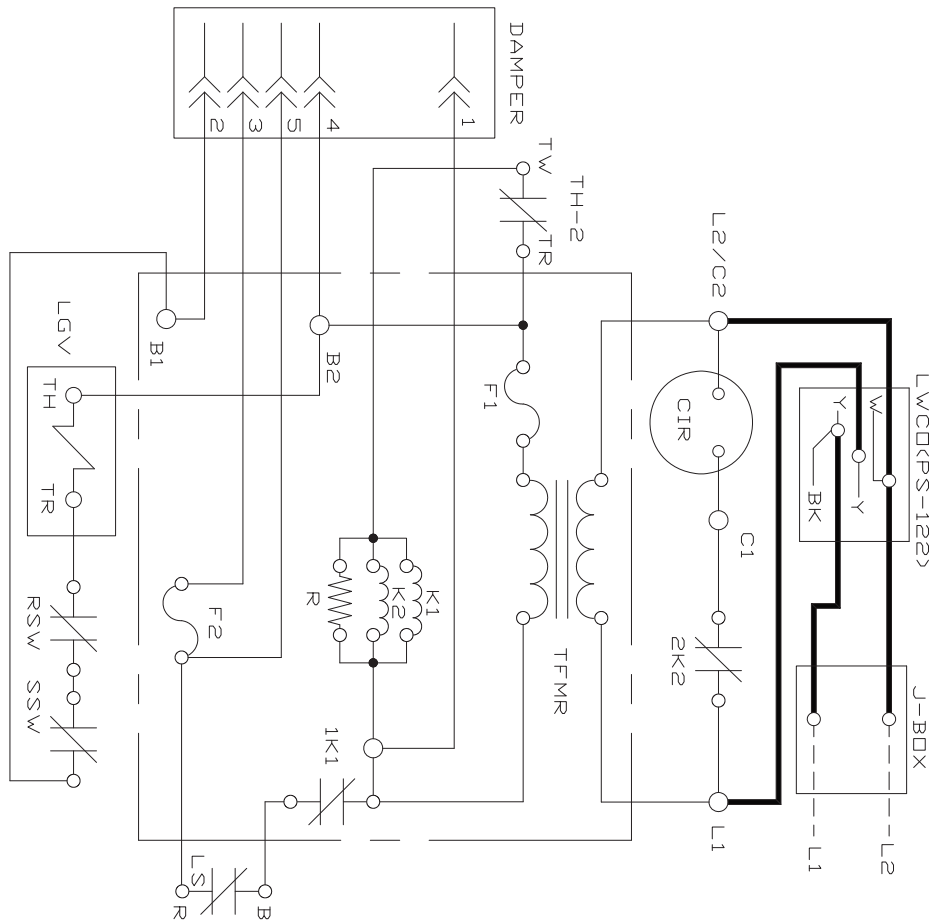
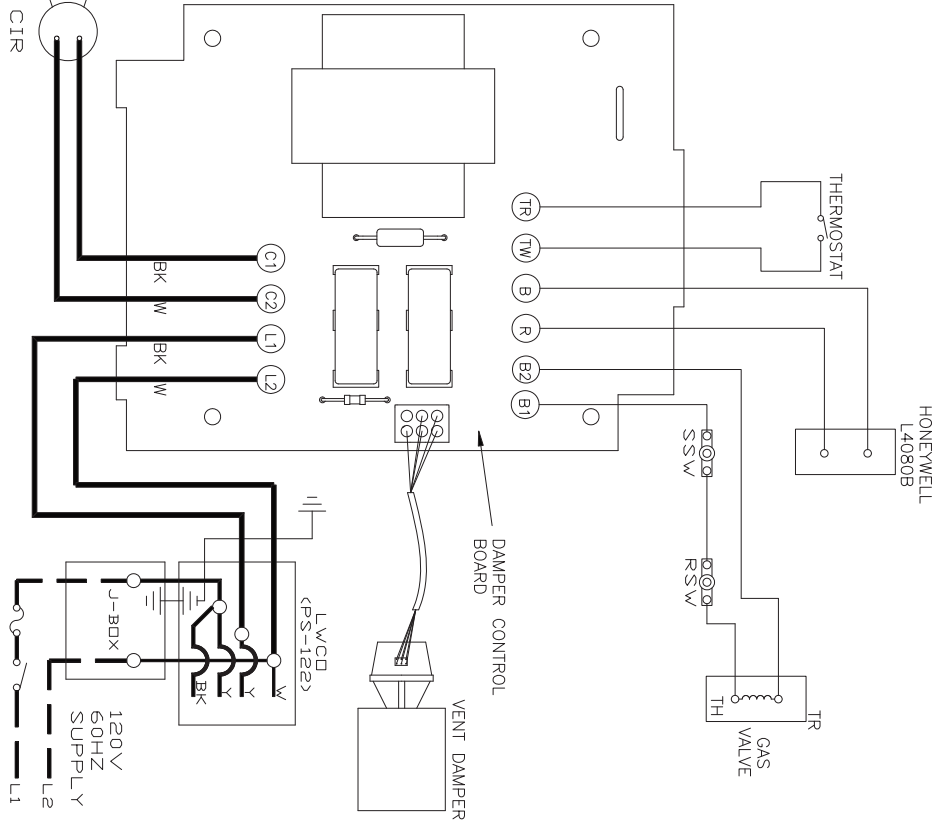

WIRING DIAGRAM

Figure 15 - 24V Interim Ignition With LWCO

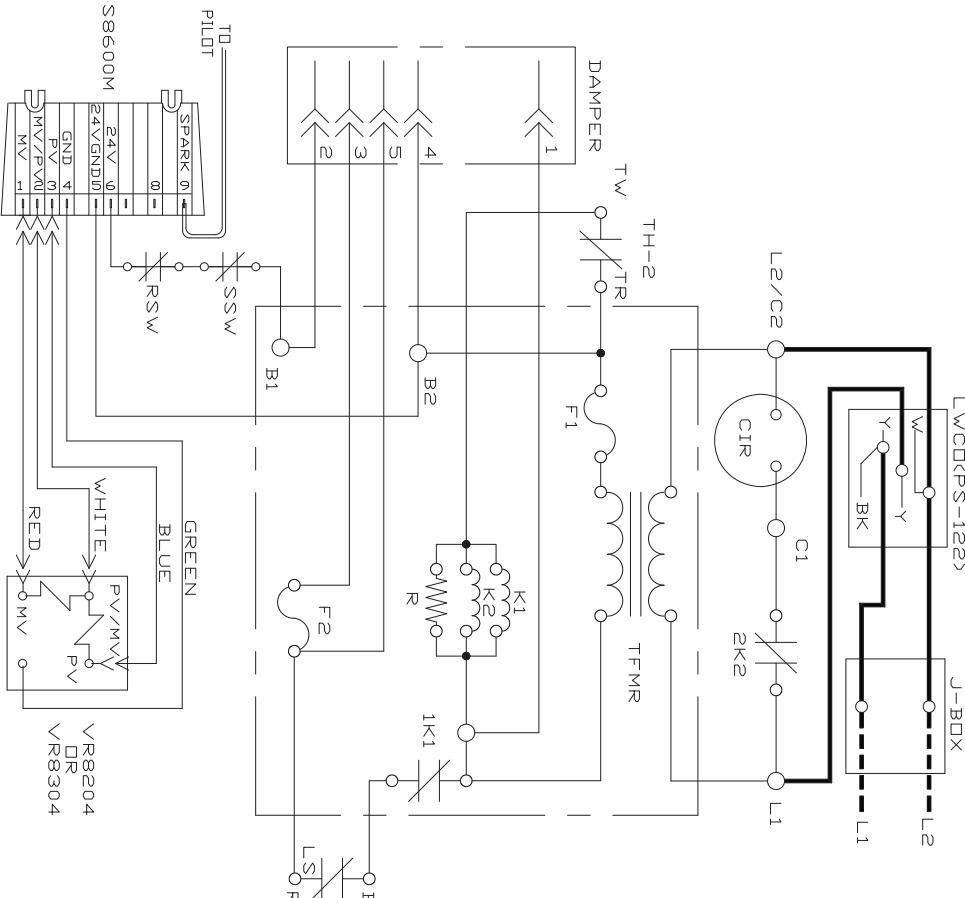
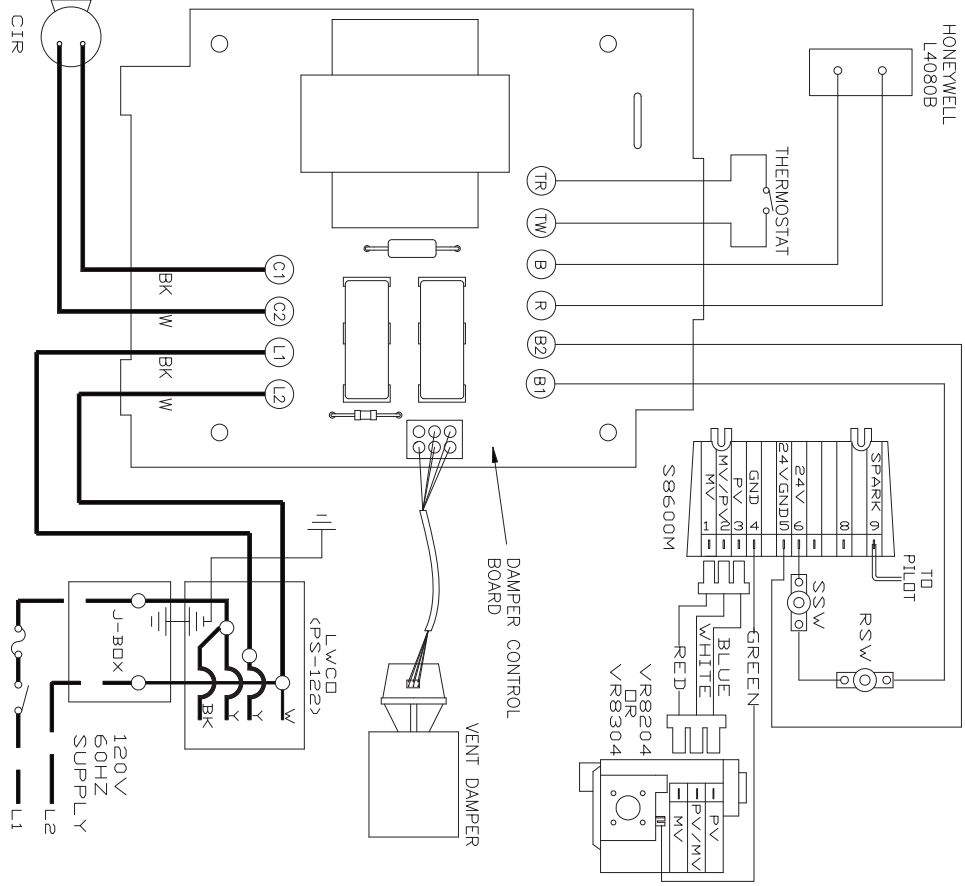

LIGHTING INSTRUCTIONS

WARNING

If you do not follow these instructions exactly, a fire or explosion may result, causing personal injury or loss of life.

Before any procedures are attempted on this appliance, it is necessary to determine if ignition system is electric or standing pilot. If you are uncertain, contact manufacturer before proceeding.

WARNING

Before lighting any type of pilot burner (standing or intermittent), make certain hot water boiler and system are full of water to minimum pressure of 12 lbs. Per square inch in system, and also make certain system is vented of air. Set operating control of thermostat to "below" normal setting. Refer to following appropriate lighting instruction.

Lighting Procedure For Boiler With Intermittent Pilot System

For Your Safety, Read Before Operating!!

- A. This appliance is equipped with an ignition device which automatically lights the pilot. Do not try to light the appliance by hand.
- B. Before operating, smell all around the appliance area for gas. Be sure to smell next to the floor because some gas is heavier than air and will settle on the floor.

CAUTION

WHAT TO DO IF YOU SMELL GAS

- Do not try to light any appliance.
- Do not touch any electrical switches; do not use any phones in your building.
- Immediately call your gas supplier from a neighbor's phone. Follow the gas supplier's instructions.
- If you cannot reach your gas supplier, call the fire department.

- C. Use only your hand to push in or turn the gas control knob. Never use tools. If the knob will not push in or turn by hand, don't try to repair it. Call a qualified service technician. Force or attempted repair may result in a fire or explosion.

- D. Do not use this appliance if any part has been under water. Immediately call a qualified service technician to inspect the appliance and to replace any part of the control system and any gas control which has been under water.

Operating Instructions For Intermittent Pilot System

1. STOP! Read the safety information to the left on this page.
2. Set the thermostat to lowest setting.
3. Turn off all electric power to the appliance.
4. This appliance is equipped with an ignition device which automatically lights the pilot. Do not try to light the pilot by hand. **Figure 16.**

Figure 16

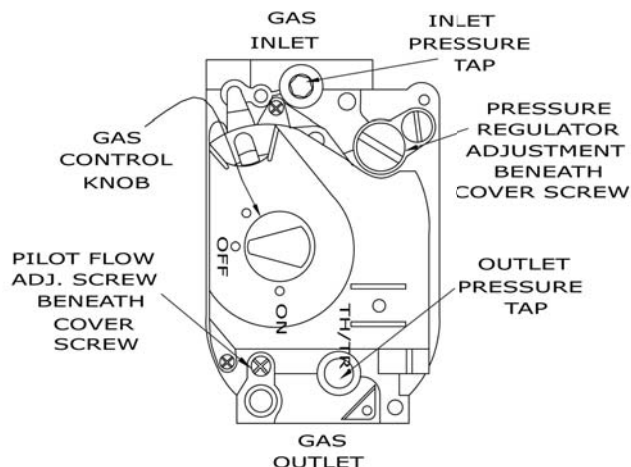

5. Turn gas control knob clockwise to "OFF."
6. Wait (5) minutes to clear out any gas. If you then smell gas, STOP! Follow "What To Do If You Smell Gas" in the safety information to left. If you don't smell gas, go on to the next step.
7. Turn gas control knob counterclockwise to "ON."
8. Turn on all electric power to the appliance.
9. Set thermostat to desired setting.
10. If the appliance will not operate, follow the instructions "To Turn Off Gas To Appliance" and call a qualified service technician or your gas supplier.

LIGHTING INSTRUCTIONS

Lighting procedure for boiler with continuous pilot For Your Safety, Read Before Lighting!

1. Read warning at beginning of "**Lighting Instructions**" on previous page.
2. This appliance has a pilot which must be lighted by hand. When lighting the pilot, follow these instructions exactly.
3. Before lighting, smell all around appliance area for gas. Be sure to smell next to floor because some gas is heavier than air and will settle on floor. See section "**What To Do If You Smell Gas**" on previous page.
4. Use only your hand to push in or turn gas control knob or reset button. Never use tools. If knob or reset button will not push in or turn by hand, don't try to repair it, call a qualified service technician. Force or attempted repair may result in a fire or explosion.
5. Do not use this appliance if any part has been under water. Immediately call a qualified service technician to inspect the appliance and to replace any part of the control system and any gas control which has been under water.

Lighting Instructions For Continuous Pilot

1. **STOP!** Read safety information above on this page.
2. Set thermostat to lowest setting.
3. Turn off all electric power to appliance.
4. Remove access panel and burner door.
5. Turn gas control knob clockwise  to "OFF."
Figures 17 and 18.

Figure 17

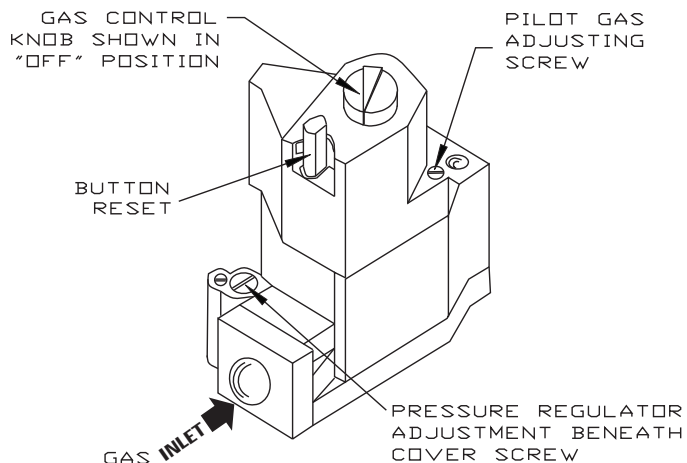
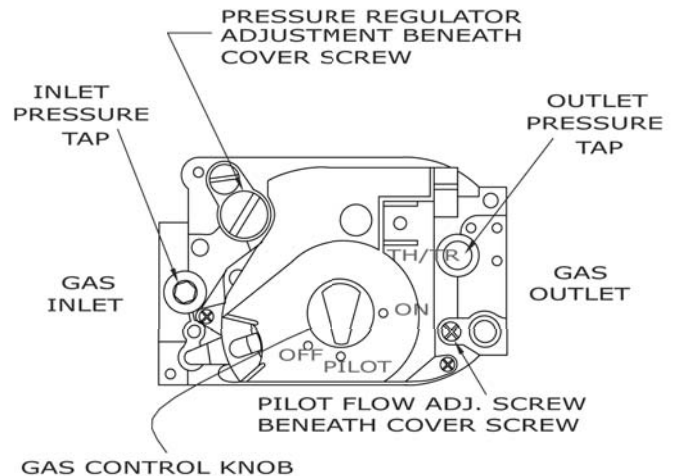





Figure 18



NOTE: Some gas control knobs cannot be turned from "PILOT" to "OFF" unless knob is pushed in slightly. **DO NOT FORCE.**

6. Wait (5) minutes to clear out any gas. If you then smell gas, STOP! Follow "**What To Do If You Smell Gas.**" If you don't smell gas, go to the next step.
7. Find pilot. Follow metal tube from gas control. Depending on model of boiler, pilot is either mounted on base or on one of burner tubes.
8. Turn gas control knob counterclockwise  to "PILOT."
9. Push in gas control knob or reset button if so equipped, all way in and hold. Immediately light pilot with match. Continue to hold gas control knob or reset button in for about 1 minute after pilot is lit. Release knob or button, and it will pop up back up. Pilot should remain lit. If it goes out, repeat steps 5 through 9.
 - If knob or button does not pop up when released, stop and immediately call a qualified service technician or your gas supplier.
 - If the pilot will not stay lit after several tries, turn the gas control knob clockwise  to "OFF." Call a qualified service technician or your gas supplier.
10. Replace burner door.
11. Turn gas control knob counterclockwise  to "ON."
12. Replace access panel.
13. Turn on all electric power to the appliance.
14. Set thermostat to desired setting.

To Turn Off Gas To The Appliance

1. Set thermostat to lowest setting.
2. Turn off all electric power to the appliance if service is to be performed.
3. Push in gas control knob slightly and turn clockwise  to "OFF." **DO NOT FORCE.**

NORMAL SEQUENCE OF OPERATION

On call for heat, thermostat will actuate, completing the circuit to control. Completed circuit to control will first activate the circulator and damper which will close an end switch inside the damper. This action will complete the circuit to the ignition system and ignition will take place.

In event the boiler water temperature exceeds high limit setting on boiler mounted high limit control, power will be interrupted between control system and ignition system. Power will remain off until boiler water temperature drops below high limit setting. Circulator will continue to operate under this condition until thermostat is satisfied.

In event flow of combustion products through boiler venting system becomes blocked, the blocked vent safety switch will shut main burner gas off. Similarly, if boiler flue-way becomes blocked, flame rollout safety switch will shut main burner gas off. **Figure 19.**

If either of these conditions occur, **DO NOT ATTEMPT TO PLACE THE BOILER BACK INTO OPERATION. CONTACT A CERTIFIED SERVICE AGENCY.**

Figure 19

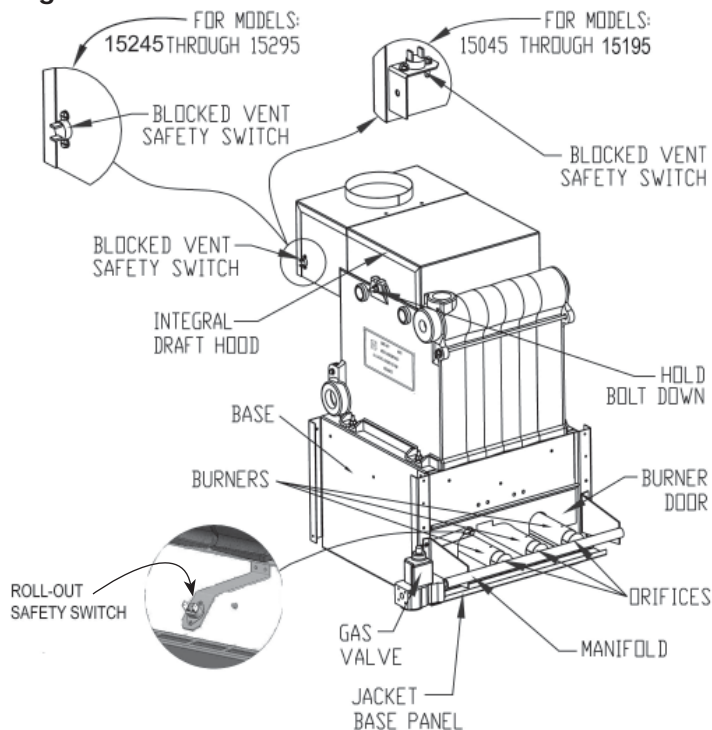

GENERAL INSTRUCTIONS

Before seasonal start-up, have a certified service agency check the boiler for soot and scale in the flues, clean the burners and check the gas input rate to maintain high operating efficiency.

CAUTION



Label all wires prior to disconnection when servicing controls. Wiring errors can cause improper and dangerous operation.

Verify proper operation after service.

The service agency or owner should make certain the system is filled with water to minimum pressure and open air vents, if used, to expel any air that may have accumulated in the system. Check the entire piping system and, if any leaks appear, have them repaired.

Circulators need to be checked and maintained. Refer to the circulator manufacturer's instructions.

The venting system should be inspected at the start of each heating season. Check the vent pipe from the boiler to the chimney for signs of deterioration by rust or sagging joints. Repair if necessary. Remove the vent pipe at the base of the chimney or flue and using a mirror, check vent for obstruction and make certain the vent is in good working order.

The boiler flue gas passageways may be inspected by a light and mirror. Remove the burner door. (Figure #20) Place a trouble lamp in the flue collector through the draft relief opening. With the mirror positioned above the burners, the flue gas passageways can be checked for soot or scale.

The following procedure should be followed to clean the flue gas passageways:

1. Remove the burners from the combustion chamber by raising the burners up from the manifold orifices and pulling toward the front of the boiler. **Figure 21.**
2. Disconnect the vent pipe from the draft hood.
3. Remove the top jacket panel.
4. Remove the combination flue collector and draft hood from the boiler castings by loosening the nuts on the hold down bolts located on each side of the collector. **Figure 19.**
5. Place a sheet of heavy paper or similar material over the bottom of the base and brush down the flue passageways. The soot and scale will collect on the paper and is easily removed with the paper.
6. With the paper still in place in the base, clean the top of the boiler castings of the boiler putty or silicone used to seal between the castings and flue collector. Make certain that chips are not lodged in the flue passageways.

GENERAL INSTRUCTIONS

When cleaning process is complete, restore boiler components to their original position. Use IS-808 GE silicone (available from a distributor) to seal around flue collector and boiler castings.

Visual check of main burner and pilot flames should be made at start of heating season and again in mid-season. Main burner flame should have well defined inner blue mantel with lighter blue outer mantel. Check burner throats and burner orifices for lint or dust obstruction. **Figures 20 and 21.**

Pilot flame should envelop $\frac{3}{8}$ to $\frac{1}{2}$ inch of tip of pilot thermocouple or ignition/sensing electrode. **Figure 21.**

To adjust pilot flame, remove pilot adjustment cover screw (**Figures 16 - 18** on previous pages) and turn inner adjustment screw counterclockwise ↺ to increase or clockwise ↻ to decrease pilot flame. Be sure to replace cover screw after adjustment to prevent possible gas leakage.

Burners and pilot should be checked for signs of corrosion, rust or scale buildup. Area around boiler must be kept clear and free of combustible materials, gasoline and other flammable vapors and liquids.

Free flow of combustion and ventilating air to boiler and boiler room must not be restricted or blocked.

It is recommended that a qualified service agency be employed to make annual inspection of boiler and heating system. They are experienced in making inspections outlined above, and, in event repairs or corrections are necessary, trained technicians can make proper changes for safe operation of boiler.

Field-sources low water cutoff(s). Inspect low water cutoff annually, or as recommended by low water cutoff manufacturer. Flush float type low water cutoffs per manufacturers instructions.

Figure 20

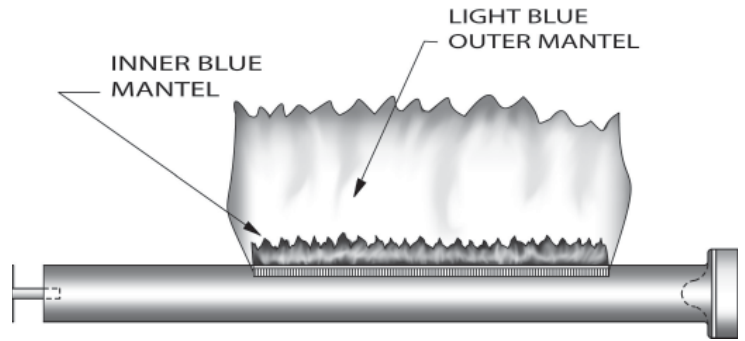

Figure 21

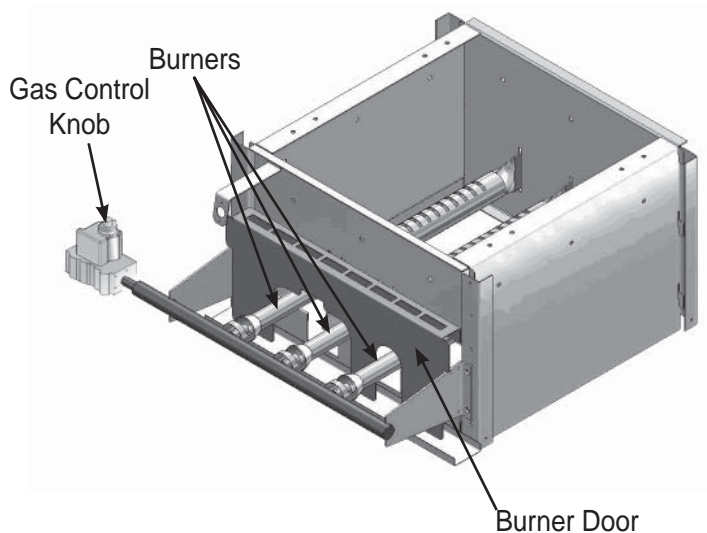
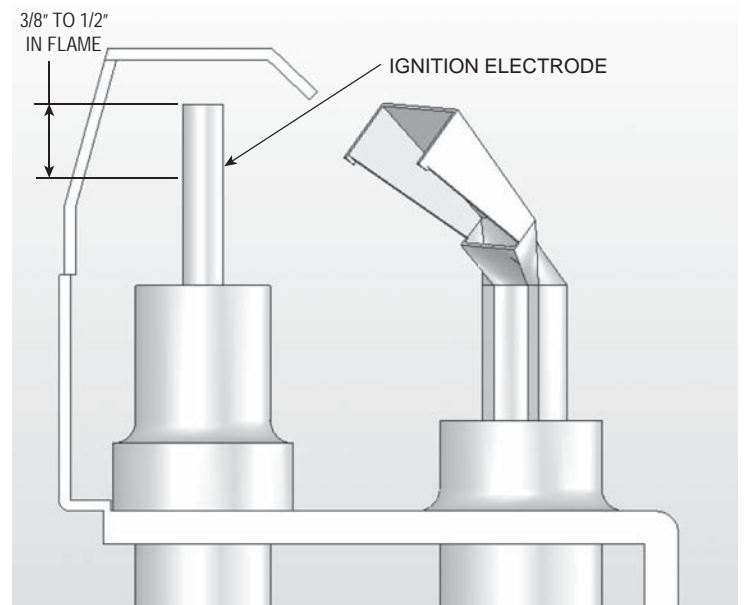



Figure 22



CHECKING GAS INPUT RATE TO BOILER

Gas input to boiler can be adjusted by removing protective cap on pressure regulator (Figures 16-18) and turning screw clockwise  to increase input and counterclockwise  to decrease input. Manifold pressures are taken at outlet side of gas valve. (Figure 16 and 18) To check for proper flow of natural gas to boiler, divide input rate shown on rating plate by heating value of gas obtained from local gas company. This will determine number of cubic feet of gas required per hour. With all other gas appliances off, determine flow of gas through meter for two minutes and multiply by 30 to get hourly rate. Make minor adjustments to gas input as described above.

Burner orifices should be changed if final manifold pressure varies more than plus or minus 0.3 inches water column from specified pressure.

Primary air adjustment is not necessary, therefore air shutters are not furnished as standard equipment. Air shutters can be furnished on request where required by local codes or conditions.

CHECK SAFETY CONTROL CIRCUIT. Ignition system safety shutoff device must be tested after placing boiler in operation.

- 1. Pilot:** With main burner operating, turn pilot gas adjusting screw clockwise  until pilot gas is turned off. (Figures 16-18 on previous pages) Within 90 seconds main gas control should close, shutting off gas to main burner.
- 2. High Limit Control (Figure 23):** Remove cover and note temperature setting. Decrease this setting to minimum and operate boiler. When boiler water temperature exceeds control temperature setting, control will open circuit, closing automatic main gas valve.

Figure 23



REPLACEMENT PARTS

BOILER EXPLODED VIEW

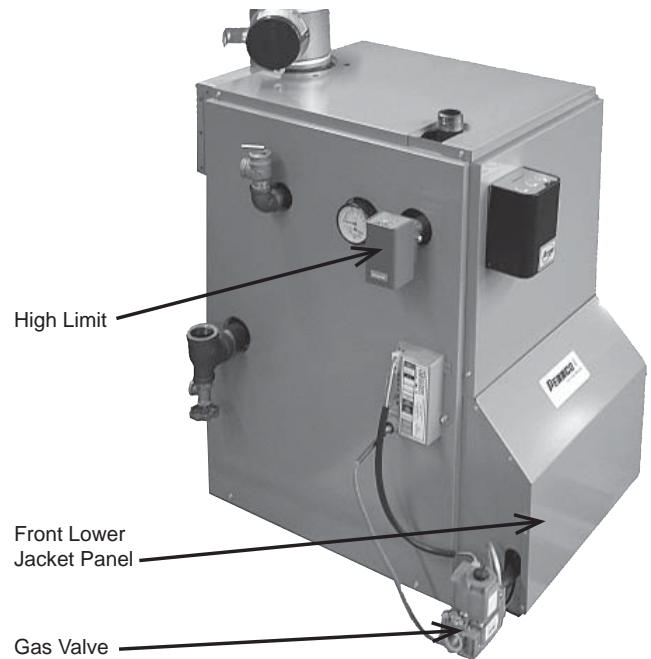
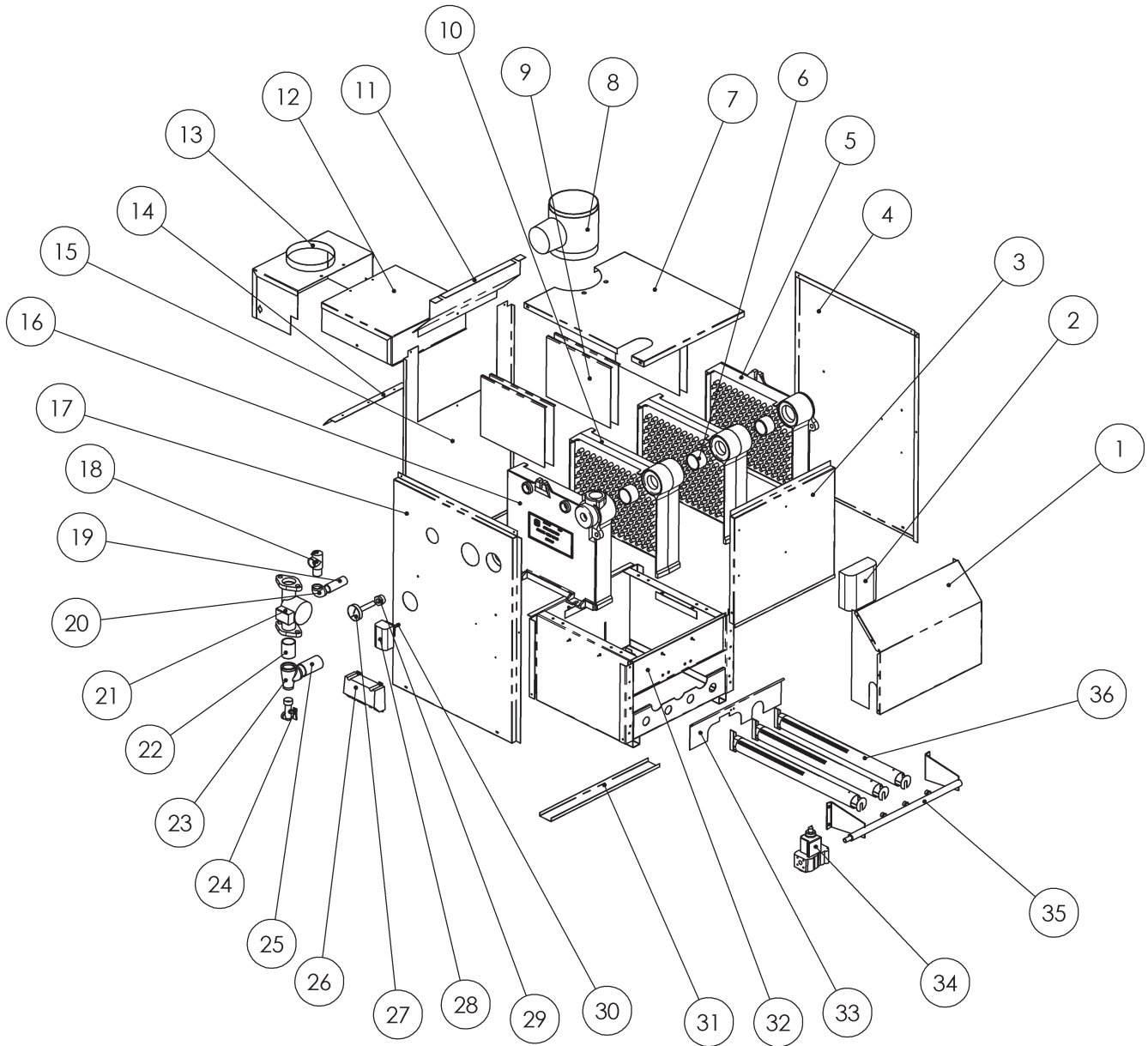

Item	Description	Item	Description	Item	Description
1	Jacket Front Lower	13	Draft Hood	25	Pipe Nipple
2	Control	14	Restrictor	26	Pilot Spark Control
3	Jacket Front Upper	15	Jacket Back	27	Temperature-Pressure Gauge
4	Jacket Side Right	16	Right End Section	28	High Limit Control
5	Left End Section	17	Jacket Side Left	29	Pipe Bushing
6	Push Nipple	18	Relief Valve	30	Well
7	Jacket Top	19	Pipe Nipple	31	Tray
8	Damper	20	Pipe Elbow	32	Base
9	Baffle	21	Circulator	33	Burner Door
10	Center Section	22	Pipe Nipple	34	Gas Valve
11	Jacket Back To Flue	23	Pipe Tee	35	Manifold
12	Flue Collector	24	Drain Cock	36	Burner Tube

REPLACEMENT PARTS

BOILER BASE

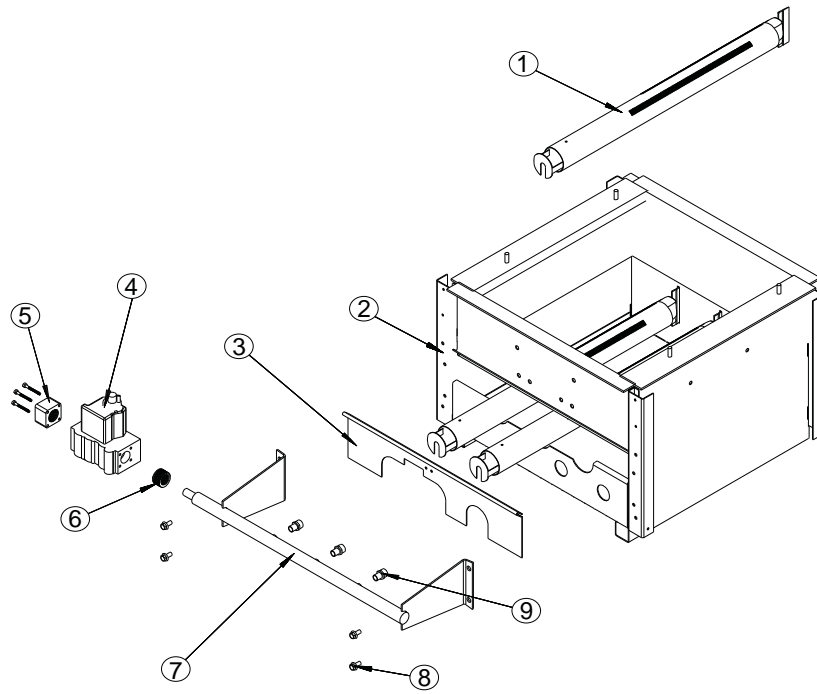

Item	Part No.	Description	QTY.
1	240005543	Burner Tube 1½" (045)	1
		Burner Tube 1½" (070, 096)	2
		Burner Tube 1½" (120, 145)	3
		Burner Tube 1½" (175, 195)	4
		Burner Tube 1½" (245)	5
		Burner Tube 1½" (295)	6
2	5611601	Base w/Insul & Bracket (045)	1
	5611602	Base w/Insul & Bracket (070, 096)	
	5611604	Base w/Insul & Bracket (175, 195)	
	5611605	Base w/Insul & Bracket (245)	
	5611606	Base w/Insul & Bracket (295)	
3	3261201	Burner Door (045)	1
	32611405	Burner Door (070, 096)	
	109008519	Burner Door (120, 145)	
	109008520	Burner Door (175, 195)	
	109008521	Burner Door (245)	
	109008522	Burner Door (295)	
4	VG-003.05	Gas Valve, 24V Nat (045-145)	1
	VG00307	Gas Valve, 24V LP (045-295)	
	VG01101	Gas Valve, Spark Nat (045-145)	
	VG01103	Gas Valve, Spark Nat (175-295)	
	VG01104	Gas Valve, Spark LP (045-295)	
	VG01201	Gas Valve, 24V Nat (245, 295)	
	VG01202	Gas Valve, 24V Nat (175, 195)	
5	VG01601	Straight Flange - ¾" NPT (175, 195, 245, 295 - LP ONLY)	1
6	VG-006.00	Internal Bushing ¾ x ½ (ALL LP)	1
7	240006792	Manifold (045)	1
	240006793	Manifold (070, 096)	

Item	Part No.	Description	Qty.
7	240006794	Manifold (120, 145)	1
	240006795	Manifold (175, 195)	
	240006796	Manifold (245)	
	240006797	Manifold (295)	
	8	HW-005.01	
9	240007406	Orifice 3.2mm, Nat. (096)	2
		Orifice 3.2mm, Nat. (145)	3
		Orifice 3.2mm Nat. (195)	4
		Orifice 3.2mm, Nat. (245)	5
		Orifice 3.2mm, Nat. (295)	6
	240007405	Orifice 3.1mm, Nat (045)	1
	240007404	Orifice 3.0mm, Nat (175)	4
	240007403	Orifice 2.9mm, Nat (120)	3
	240007402	Orifice 2.8mm, Nat (070)	2
	355-1-520	Orifice #45, LP (045)	1
	355-1-5.04	Orifice #47, LP (096)	2
		Orifice #47, LP (145)	3
		Orifice #47, LP (195)	4
		Orifice #47, LP (245)	5
	355-1-5.06	Orifice #47, LP (295)	6
Orifice #49, LP (120)		3	
Orifice #49, LP (175)		4	
355-1-5.07	Orifice #50, LP (070)	2	
NOT SHOWN	325-2-8.01	Combustible Base Flooring - 45	1
	325-2-8.02	Combustible Base Flooring - 70, 96	
	325-2-8.03	Combustible Base Flooring - 120, 145	
	325-2-8.04	Combustible Base Flooring - 175, 195	
	325-2-8.05	Combustible Base Flooring - 245	
	325-2-8.06	Combustible Base Flooring - 295	

REPLACEMENT PARTS

HEAT EXCHANGER

Fully Assembled Heat Exchangers	
912000001	Heat Exchanger (2 Section)
912000002	Heat Exchanger (3 Section)
912000003	Heat Exchanger (4 Section)
912000004	Heat Exchanger (5 Section)
912000005	Heat Exchanger (6 Section)
912000006	Heat Exchanger (7 Section)

PIPING & CONTROLS

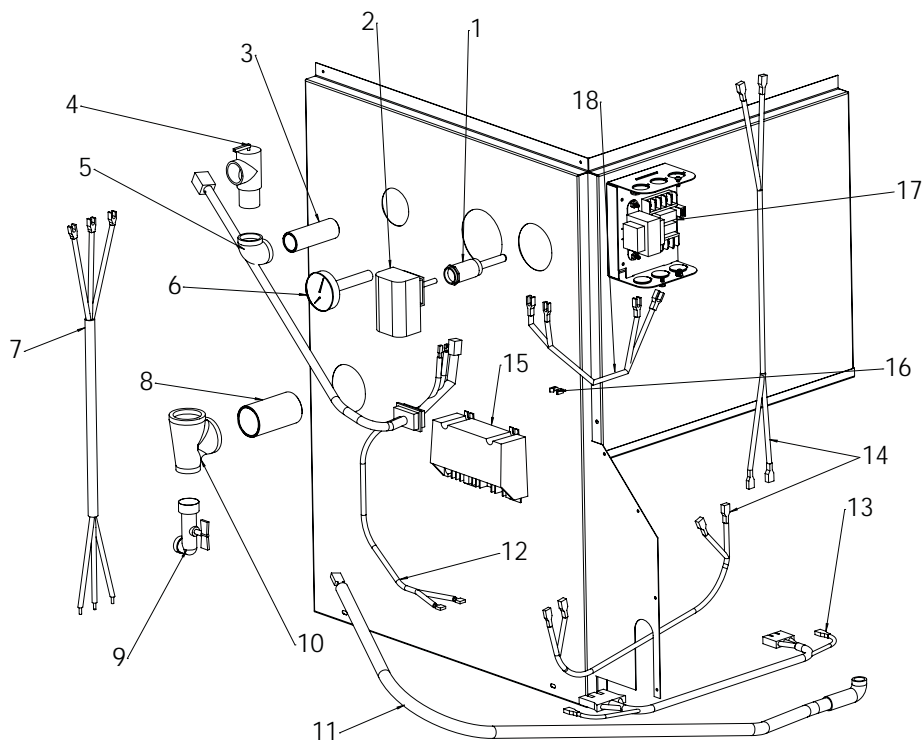

Item	Part No.	Description	Qty.
1	AQ-020.01	Well ¾" x 3"	1
2	AQ02201	High Limit Control	1
3	1310001	Pipe - Nipple ¾" x 4"	1
4	VR-001.01	Relief Valve 30#	1
5	1190001	Pipe - Elbow ¾" 90°	1
6	1260006	Gauge - Theraltimeter	1
7	37519501	Harness Circulator 72"	1
8	1310002	Pipe - Nipple 1¼" x 4½" NPT	1
9	HW-016.03	Drain Valve	1

Item	Part No.	Description	Qty.
10	1516001	Pipe - Tee 1¼" x ¾" x 1¼"	1
11	240007093	Pilot Ignition Cable 30"	1
12	375-1-14.01	Wire - Low Voltage/Damper	1
13	37413602	Harness - Ignition to Gas Valve 18"	1
14	37513301	Wire - Rollout/Spill 28"	2
15	14662070	Pilot Spark Control	1
16	EF03601	Clamp #3600 White	2
17	Z99	Control Vent Damper	1
18	240004779	Wire, 2 Cond., Bonded 18"	1

REPLACEMENT PARTS

BOILER JACKET

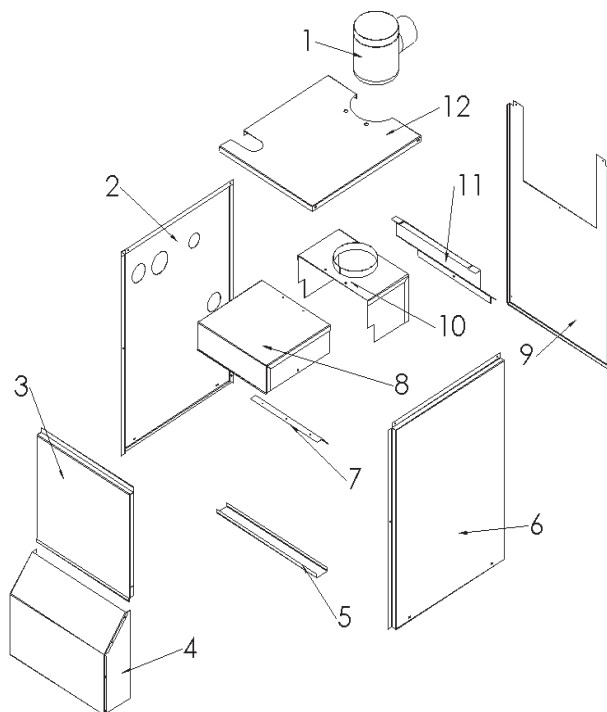

Item	Part No.	Description	Qty.
1	240006936	4" Damper (045)	1
	240006937	5" Damper (070, 096)	
	240006938	6" Damper (120, 145)	
	240006939	7" Damper (175, 195)	
	240006940	8" Damper (245)	
	240006941	9" Damper (295)	
2	31623101	Jkt Side Left Panel (046-295)	1
3	31623001	Jkt Front Upper (045)	1
	31623002	Jkt Front Upper (070, 096)	
	31623003	Jkt Front Upper (120, 145)	
	31623004	Jkt Front Upper (175, 195)	
	31623005	Jkt Front Upper (245)	
	31623006	Jkt Front Upper (295)	
4	31622001	Jkt Front Lower (045)	1
	31622002	Jkt Front Lower (070, 096)	
	31622003	Jkt Front Lower (120, 145)	
	31622004	Jkt Front Lower (175, 195)	
	31622005	Jkt Front Lower (245)	
	31622006	Jkt Front Lower (295)	
5	31622701	Tray (045)	1
	31622702	Tray (070, 096)	
	109008558	Tray (120, 145)	
	109008559	Tray (175, 195)	
	109008521	Tray (245)	
	109008522	Tray (295)	
6	31623201	Jkt Side Right Panel (046-295)	1
7	3461701	Flue Collector Restrictor (045)	1
	3461702	Flue Collector Restrictor (070)	

Item	Part No.	Description	Qty.
8	34620501	Flue Collector (045)	1
	109008571	Flue Collector (070, 096)	
	109008554	Flue Collector (120, 145)	
	109008555	Flue Collector (175, 195)	
	34620505	Flue Collector (245)	
	109008573	Flue Collector (295)	
9	31623301	Jkt Back Panel (045)	1
	31623302	Jkt Back Panel (070, 096)	
	31623303	Jkt Back Panel (120, 145)	
	31623304	Jkt Back Panel (175, 195)	
	31623305	Jkt Back Panel(245)	
	31623306	Jkt Back Panel (295)	
10	34620601	Draft Hood (045)	1
	34620602	Draft Hood (070, 096)	
	34620603	Draft Hood (120, 145)	
	34620604	Draft Hood (175, 195)	
	34620605	Draft Hood (245)	
	34620606	Draft Hood (295)	
11	31623501	Jkt Back to Flue (045)	1
	31623502	Jkt Back to Flue (070, 096)	
	31623503	Jkt Back to Flue (120, 145)	
	31623504	Jkt Back to Flue (175, 195)	
	31623505	Jkt Back to Flue (245)	
	31623506	Jkt Back to Flue (295)	
12	31622901	Jkt Top Panel (045)	1
	31622902	Jkt Top Panel (070, 096)	
	31622903	Jkt Top Panel (120, 145)	
	31622904	Jkt Top Panel (175, 195)	
	31622905	Jkt Top Panel (245)	
	31622906	Jkt Top Panel (295)	

REPLACEMENT PARTS

STANDING PILOT

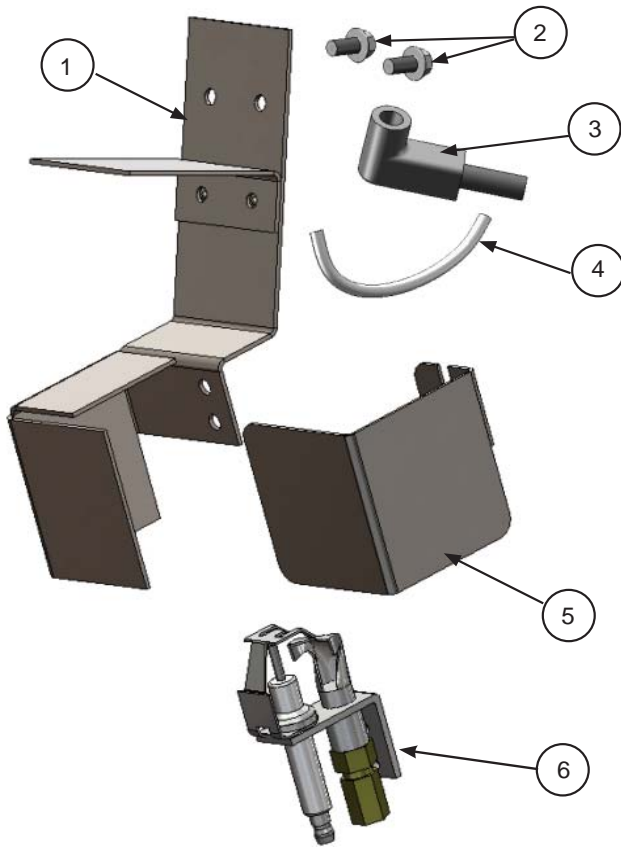

Spark Pilot Kit - Natural Gas 550001911 Spark Pilot Kit - LP/Propane 550001912		
Item	Description	Qty.
1	PILOT BRACKET ASSEMBLY	1
2	BRACKET SCREW	2
3	SPARK CABLE	1
4	PILOT TUBING, 1/8" x 24"	1
5	PILOT SHIELD	1
6	IGNITER	1

CONTINUOUS PILOT

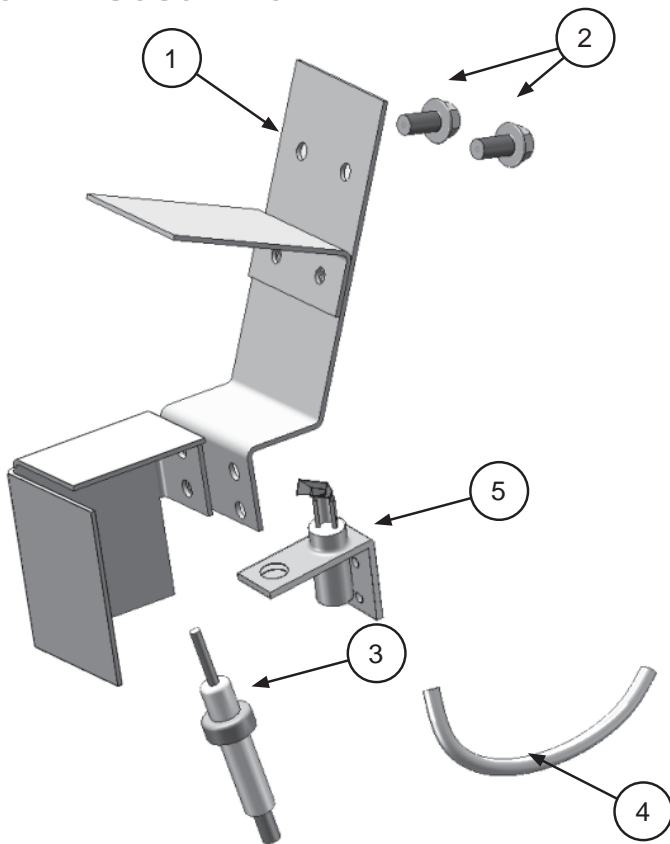

Continuous Pilot Kit - Natural Gas 550001926 Continuous Pilot Kit - LP/Propane 550001927		
Item	Description	Qty.
1	PILOT BRACKET ASSEMBLY	1
2	BRACKET SCREW	2
3	THERMOCOUPLE Q309	1
4	PILOT TUBING, 1/8" x 24"	1
5	PILOT	1

CONVERSION KITS

ROLLOUT & SPILL SWITCH

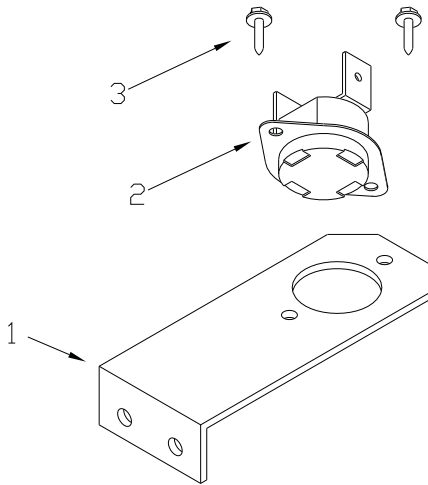

ITEM	PART NO.	DESCRIPTION	QTY.*
1	32611001	2 Section Temp. Sensor Bracket	1
	3161202	3 Section Temp. Sensor Bracket	1
	109008517	4 Section Temp. Sensor Bracket	1
	109008518	5-7 Section Temp. Sensor Bracket	1
2	AQ02101	Control - Fixed Temperature Thermostat (Rollout Switch)	1
3	HW06501	Screw - #6 x 1/4" Hex HD	2

NOTES:

- (1) The rollout switch is located on the manifold bracket.
- (2) The quantities above are for each switch.

CONVERSION KITS

NATURAL GAS TO LP		
Model	Part No.	Description
15B045	550001279	Kit, Conversion, Natural to LP
15B070	550001280	Kit, Conversion, Natural to LP
15B096	550001281	Kit, Conversion, Natural to LP
15B120	550001282	Kit, Conversion, Natural to LP
15B145	550001283	Kit, Conversion, Natural to LP
15B175	550001284	Kit, Conversion, Natural to LP
15B195	550001285	Kit, Conversion, Natural to LP
15B245	550001286	Kit, Conversion, Natural to LP
15B295	550001287	Kit, Conversion, Natural to LP

LP TO NATURAL GAS		
Model	Part No.	Description
15B045	550001270	Kit, Conversion, LP to Natural
15B070	550001271	Kit, Conversion, LP to Natural
15B096	550001272	Kit, Conversion, LP to Natural
15B120	550001273	Kit, Conversion, LP to Natural
15B145	550001274	Kit, Conversion, LP to Natural
15B175	550001275	Kit, Conversion, LP to Natural
15B195	550001276	Kit, Conversion, LP to Natural
15B245	550001277	Kit, Conversion, LP to Natural
15B295	550001278	Kit, Conversion, LP to Natural



UTICA HEATING
2201 Dwyer Avenue, Utica NY 13501
web site: www.ecrinternational.com
