



USER'S INFORMATION MANUAL

SERIES UH15B CAST IRON GAS FIRED BOILERS FOR FORCED HOT WATER

WARNING: If the information in this manual is not followed exactly, a fire or explosion may result causing property damage, personal injury or loss of life.

- Do not store or use gasoline or other flammable vapors and liquids in the vicinity of this or any other appliance.

- WHAT TO DO IF YOU SMELL GAS
 - Do not try to light any appliance.
 - Do not touch any electrical switch; do not use any phone in your building.
 - Immediately call your gas supplier from a neighbor's phone. Follow the gas supplier's instructions.
 - If you cannot reach your gas supplier, call the fire department.

- Installation and service must be performed by a qualified installer, service agency or the gas supplier.

Do not use this boiler if any part has been under water. Immediately call a qualified service technician to inspect the boiler and to replace any part of the control system and any gas control which has been under water.

Should overheating occur or the gas supply fail to shut off, do not turn off or disconnect the electrical supply to the pump. Instead, shut off the gas supply at a location external to the appliance.

Information and specifications outlined in this manual in effect at the time of printing of this manual. ECR International reserves the right to discontinue, change specifications or system design at any time without notice and without incurring any obligation, whatsoever.

UTICA HEATING
2201 Dwyer Avenue, Utica NY 13501
web site: www.ecrinternational.com

Check our website frequently for updates: www.ecrinternational.com

P/N 1305027UH, Rev. B [8/2011]

KEEP THIS MANUAL NEAR BOILER
RETAIN FOR FUTURE REFERENCE

SAFETY SYMBOLS & WARNINGS

The following defined symbols are used throughout this manual to notify the reader of potential hazards of varying risk levels.

	DANGER
	Indicates a hazardous situation which, if not avoided, WILL result in death or serious injury.

	CAUTION
	Indicates a hazardous situation which, if not avoided, may result in minor or moderate injury.

	WARNING
	Indicates a hazardous situation which, if not avoided, could result in death or serious injury.

	NOTICE
	Indicates information which should be followed to ensure proper installation and operation.



LIGHTING INSTRUCTIONS

WARNING



Before lighting any type of pilot burner (standing or intermittent), make certain the hot water boiler and system are full of water to minimum pressure of 12 lbs. per square inch in the system, and also make certain system is vented of air. Refer to the following appropriate lighting instruction.

Lighting Procedure For Boiler With Intermittent Pilot System

WARNING



If you do not follow these instructions exactly, a fire or explosion may result causing property damage, personal injury or loss of life.

- A. This appliance is equipped with an ignition device which automatically lights the pilot. Do not try to light pilot by hand.
- B. Before operating, smell all around the appliance area for gas. Be sure to smell next to the floor because some gas is heavier than air and will settle on the floor. Read *"What To Do If You Smell Gas"* on front cover of this manual.
- C. Use only your hand to push in or turn the gas control knob. Never use tools. If the knob will not push in or turn by hand, don't try to repair it. Call a qualified service technician. Force or attempted repair may result in a fire or explosion.
- D. Do not use this appliance if any part has been under water. Immediately call a qualified service technician to inspect the appliance and to replace any part of the control system and any gas control which has been under water.

Operating Instructions For Intermittent Pilot System

1. **STOP!** Read the safety information above.
2. Set the thermostat to lowest setting.
3. Turn off all electric power to the appliance.



4. This appliance is equipped with an ignition device which automatically lights the pilot. Do not try to light the pilot by hand.
5. Turn gas control knob clockwise  to "OFF." See Figure 1.
6. Wait (5) minutes to clear out any gas. If you then smell gas, **STOP!** Follow *"What To Do If You Smell Gas"* on front cover of this manual. If you don't smell gas, go on to the next step.
7. Turn gas control knob counterclockwise  to "ON."
8. Turn on all electric power to the appliance.
9. Set thermostat to desired setting.
10. If the appliance will not operate, follow the instructions in *"To Turn Off Gas To Appliance"* on following page and call a qualified service technician or your gas supplier.

Figure 1 - Intermittent Pilot



Lighting Procedure For Boiler With Continuous Pilot System

For your safety read before Lighting.

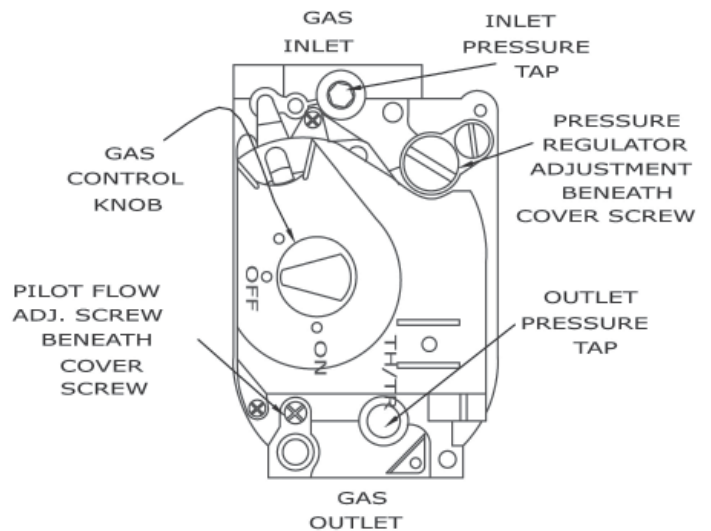
WARNING



If you do not follow these instructions exactly, a fire or explosion may result causing property damage, personal injury or loss of life.

- A. This appliance has a pilot which must be lighted by hand. When lighting the pilot, follow these instructions exactly.
- B. Before lighting, smell all around the appliance area for gas. Be sure to smell next to the floor because some gas is heavier than air and will settle on the floor. Read *"What To Do If You Smell Gas"* in the front of this manual.
- C. Use only your hand to push in or turn gas control knob or reset button. Never use tools. If the knob or reset button will not push in or turn by hand, don't try to repair it, call a qualified service technician. Force or attempted repair may result in a fire or explosion.
- D. Do not use this appliance if any part has been under water. Immediately call a qualified service technician to inspect the appliance and to replace any part of the control system and any gas control which has been under water.

Lighting Instructions For Continuous Pilot

1. **STOP!** Read the safety information above.
2. Set the thermostat to lowest setting.
3. Turn off all electric power to the appliance.
4. Remove access panel and burner door.
5. Turn gas control knob clockwise  to "OFF."
See Figures 2 and 3.

Note* Some gas control knobs cannot be turned from "PILOT" to "OFF" unless knob is pushed in slightly. **DO NOT FORCE.**

6. Wait (5) minutes to clear out any gas. If you then smell gas, STOP! Follow *"What To Do If You Smell Gas"* on the front cover of this manual. If you don't smell gas, go to the next step.
7. Find pilot. Follow metal tube from gas control. Depending on the model of the boiler, pilot is either mounted on the base or on one of the burner tubes.

Figure 2 - Gas Control Knob

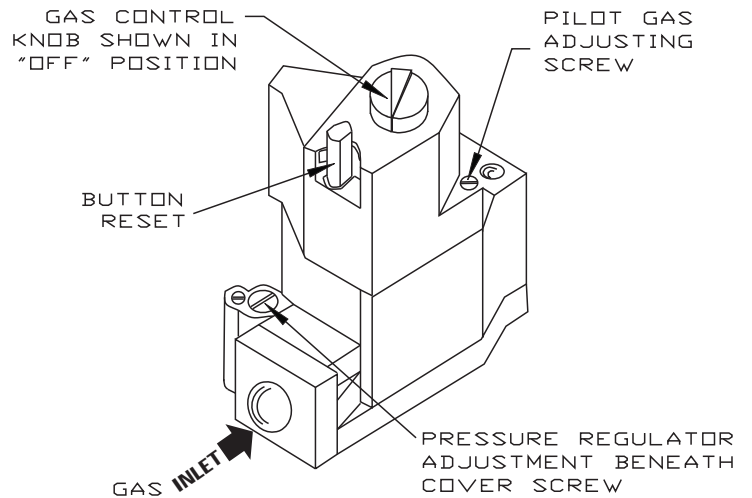
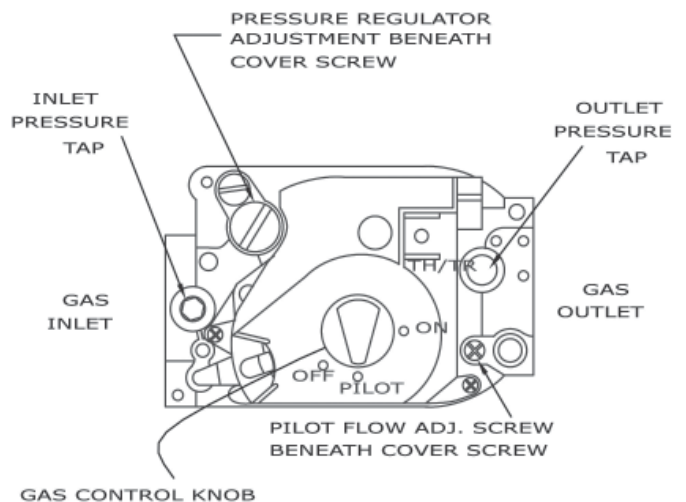





Figure 3 - Continuous Pilot Gas Valve



8. Turn gas control knob counterclockwise  to "PILOT."
9. Push in gas control knob or reset button if so equipped, all the way in and hold. Immediately light the pilot with a match. Continue to hold the gas control knob or reset button in for about 1 minute after the pilot is lit. Release knob or button, and it will pop up back up. Pilot should remain lit. If it goes out, repeat steps 5 through 9.
 - * If knob or button does not pop up when released, stop and immediately call a qualified service technician or your gas supplier.
 - * If the pilot will not stay lit after several tries, turn the gas control knob clockwise  to "OFF" and call a qualified service technician or your gas supplier.
10. Replace burner door.

LIGHTING INSTRUCTIONS

11. Turn gas control knob counterclockwise  to "ON."
12. Replace access panel.
13. Turn on all electric power to the appliance.
14. Set thermostat to desired setting.

To Turn Off Gas To Appliance

1. Set the thermostat to lowest setting.
2. Turn off all electric power to the appliance if service is to be performed.
3. Push in gas control knob slightly and turn clockwise  to "OFF." DO NOT FORCE.
4. Replace access panel.

GENERAL INSTRUCTIONS

Before seasonal start-up, have a qualified service agency check the boiler for soot and scale in the flues, clean the burners and check the gas input rate to maintain high operating efficiency.

Put about one half teaspoon of SAE 20 or 30 non-detergent motor oil in each opening twice a year.



CAUTION

Do Not Over Oil!!



CAUTION

Label all wires prior to disconnection when servicing controls. Wiring errors can cause improper and dangerous operation.

Many circulators have an oil opening for the shaft bearing. This should be oiled at the same time for quiet operation. Follow the manufacturer's instructions for oiling the shaft bearing.

Verify proper operation after service.

The service agency or owner should make certain the system is filled with water to minimum pressure and open air vents, if used, to expel any air that may have accumulated in the system. Check the entire piping system and, if any leaks appear, have them repaired.

The venting system should be inspected at the start of each heating season. Check the vent pipe from the boiler to the chimney for signs of deterioration by rust or sagging joints. Repair if necessary. Remove the vent pipe at the base of the chimney or flue and using a mirror, check vent for obstruction and make certain the vent is in good working order.

Figure 4 - Circulator



Many circulators like the one pictured in Figure 4 (above) require periodic servicing. The motor usually has openings at each end to lubricate the bearings.

Figure 5 - Boiler Flue Gas Passageways

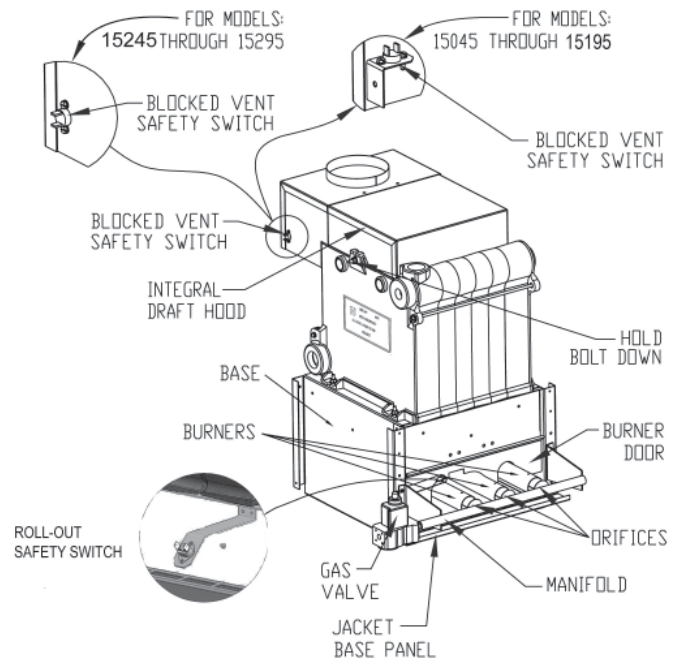

GENERAL INSTRUCTIONS

The boiler flue gas passageways may be inspected by a light and mirror. Remove the burner door. Place a trouble lamp in the flue collector through the draft relief opening. With the mirror positioned above the burners, the flue gas passageways can be checked for soot or scale. See Figure 5.

In the event the flow of combustion products through the boiler venting system becomes blocked, the blocked vent safety switch will shut the main burner gas off. If this condition occurs, **do not attempt to place the boiler in operation. Contact a qualified service agency.**

If the boiler flue-ways become blocked, a flame rollout safety switch will shut the main burner gas off. If this condition occurs, **do not attempt to place the boiler in operation. Contact a qualified service agency.**

To Clean The Flue Gas Passageways



1. Remove the burners from the combustion chamber by raising the burners up from the manifold orifices and pulling toward the front of the boiler. See Figure 8.
2. Disconnect the vent pipe from the draft hood.
3. Remove the top jacket panel.
4. Remove the combination flue collector and draft hood from the boiler castings by loosening the nuts on the hold down bolts located on each side of the collector.
5. Place a sheet of heavy paper or similar material over the bottom of the base and brush down the flue passageways. The soot and scale will collect on the paper and is easily removed with the paper.

With the paper still in place in the base, clean the top of the boiler castings of the boiler putty or silicone used to seal between the castings and flue collector. Make certain that chips are not lodged in the flue passageways.

When the cleaning process is complete, restore the boiler components to their original position. Use boiler putty or IS-808 GE silicone (available from the distributor) to seal around the flue collector and boiler castings.

A visual check of the main burner and pilot flames should be made at the start of the heating season and again mid-season. The main burner flame should have a well defined inner blue mantel with a lighter blue outer mantel. Check the burner throats and burner orifices for lint or dust obstruction. See Figures 6, 7 and 8.

The pilot flame should envelop 3/8 to 1/2 inch of the tip of the pilot thermocouple, ignition/sensing electrode or mercury sensor.

To adjust the pilot flame, remove the pilot adjustment cover screw and turn the inner adjustment screw counterclockwise  to increase or clockwise  to decrease pilot flame. Be sure to replace cover screw after adjustment to prevent possible gas leakage.

The burners and pilot should be checked for signs of corrosion, rust or scale build-up. The area around the boiler must be kept clear and free of combustible materials, gasoline and other flammable vapors and liquids.

The free flow of combustion and ventilating air to the boiler and boiler room must not be restricted or blocked.

It is suggested that a qualified service agency be employed to make an annual inspection of the boiler and heating system. They are experienced in making the inspections outlined above and, in the event repairs or corrections are necessary, can make the proper changes for safe operation of the boiler.

Figure 6 - Burner Flame

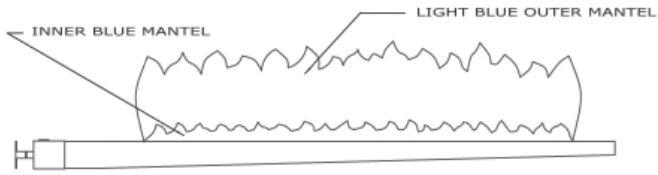

Figure 7 - Burner Pilot Flame

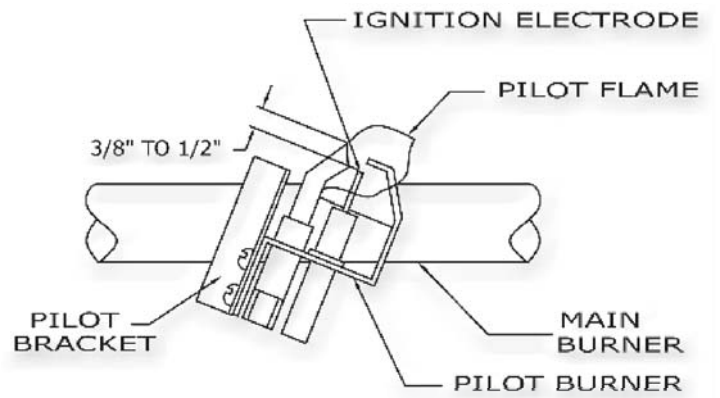
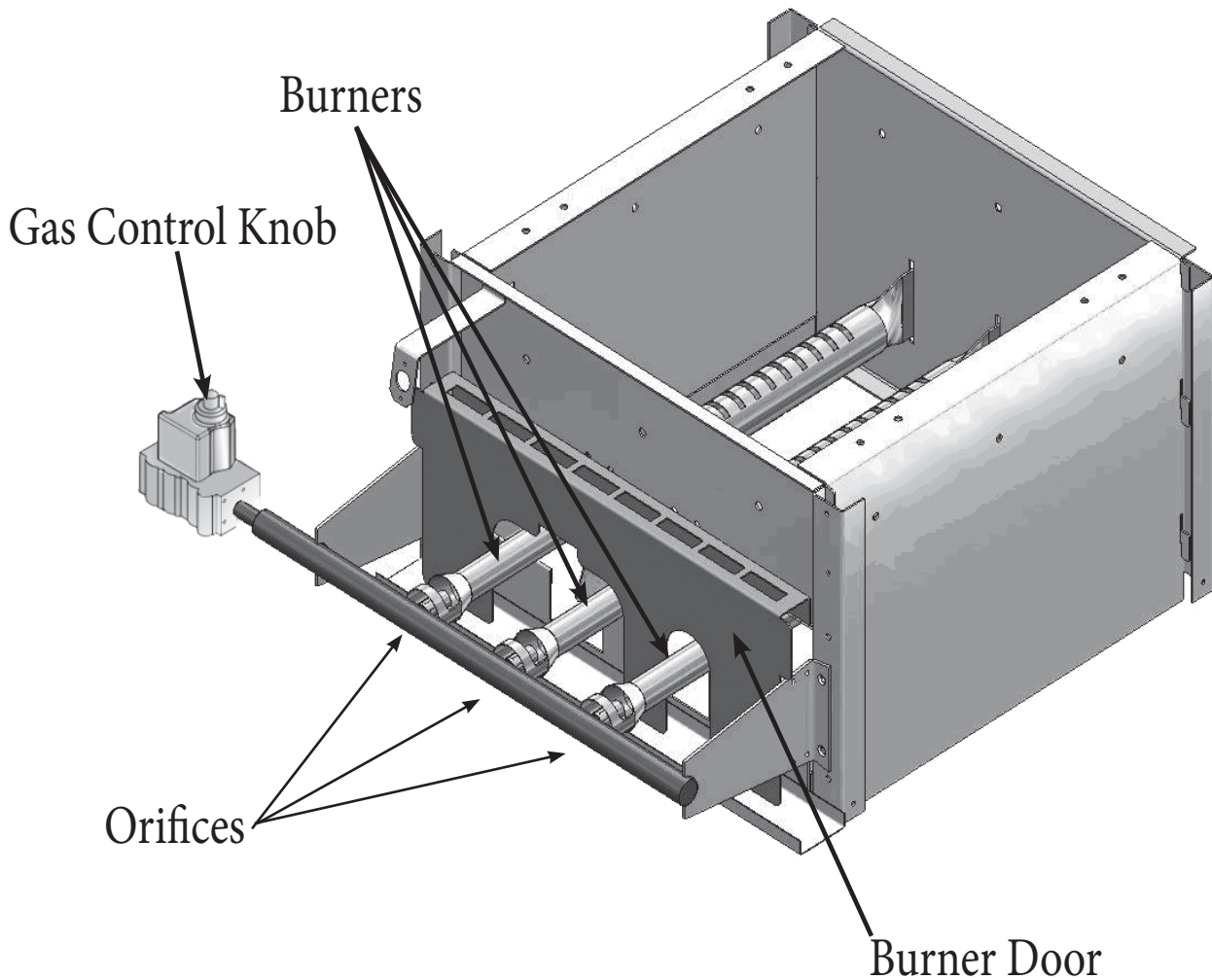

Figure 8 - Burners, Burner Orifices



NOTES

UTICA HEATING

Date of Installation: _____

Boiler Model #: _____

Installed By: _____



UTICA HEATING
2201 Dwyer Avenue, Utica NY 13501
web site: www.ecrinternational.com