

INSTALLATION MANUAL AND OPERATING INSTRUCTIONS

**EMPIRE STEAM II
OIL-FIRED CAST IRON BOILER**

MODEL NUMBERS:
ESB0365, ESB3100,
ESB4125, ESB4150,
ESB5175, ESB5200,
ESB6225, ESB7275



DUNKIRK
85 Middle Road
Dunkirk, NY 14048
Phone: (716) 366-5500
Fax: (716) 366-1209
www.dunkirk.com

An **ECR International Brand**
An ISO 9001-2000 Certified Company



INSTALLATION MANUAL AND OPERATING INSTRUCTIONS

P/N# 1305029, Rev. 1.0 [08/04] • Printed in USA • Made In USA

TABLE OF CONTENTS

Safety Symbols and Warnings	2
Ratings, Data, and Dimensions	3
Installation Procedure	4
Ventilation and Combustion Air	5
Connecting Supply and Return Piping Steam	7
Venting System Inspection and Installation	8
Oil Tank and Piping	8
Electrical Wiring	9
Thermostat Operation	9
Normal Sequence of Operation	11
Operating Instructions	11
Maintenance Procedures	14
Replacement Parts List	15
Service Checklist	20

KEEP THIS MANUAL NEAR BOILER
RETAIN FOR FUTURE REFERENCE

SAFETY SYMBOLS & WARNINGS

The following defined symbols are used throughout this manual to notify the reader of potential hazards of varying risk levels.



Indicates an imminently hazardous situation which, if not avoided, **WILL** result in death or serious injury.



Indicates a potentially hazardous situation which, if not avoided, **COULD** result in death or serious injury.



Indicates a potential hazardous situation which, if not avoided, **MAY** result in minor or moderate injury. It may also be used to alert against unsafe practices.

IMPORTANT: Read the following instructions **COMPLETELY** before installing!!



1. Keep boiler area clear and free from combustible materials, gasoline and other flammable vapors and liquids.
2. **DO NOT** obstruct air openings to the boiler room.
3. Modification, substitution or elimination of factory equipped, supplied or specified components may result in property damage, personal injury or the loss of life.
4. **TO THE OWNER** - Installation and service of this boiler must be performed by a qualified installer.
5. **TO THE INSTALLER** - Leave all instructions with the boiler for future reference.
6. When this product is installed in the Commonwealth of Massachusetts the installation must be performed by a Licensed Plumber or Licensed Gas Fitter.



All installations of boilers and venting should be done only by a qualified expert and in accordance with the appropriate Pennco manual. Installing or venting a boiler or any other gas appliance with improper methods or materials may result in serious injury or death due to fire or to asphyxiation from poisonous gases such as carbon monoxide which is odorless and invisible.



Tested For 15 LBS.
ASME
Working Pressure

RATINGS, DATA, AND DIMENSIONS

Boiler Model Number ⁽¹⁾	I=B=R Oil Burner Input ⁽²⁾		D.O.E. Heating Capacity MBH ⁽⁴⁾	I=B=R Net Ratings ⁽³⁾⁽⁴⁾			Min. Natural Draft Chimney Size		Pump Pressure PSI	Nozzle Furnished 140PSIG ⁽⁵⁾	A.F.U.E. Rating
	G.P.H.	MBH ⁽⁴⁾		Steam MBH	Sq. Ft. Steam	Water MBH	Round	Square			
ESB0365	0.65	91	78	59	246	68	6	8x8x15	140	.60 80B	84
ESB3100	1.00	140	116	87	363	101	6	8x8x15	140	.85 80B	81.5
ESB4125	1.25	175	145	109	454	126	7	8x8x15	140	1.10 80B	82.5
ESB4150	1.50	210	170	128	533	148	7	8x8x15	140	1.25 80B	81
ESB5175	1.75	245	202	152	633	176	8	8x8x15	140	1.50 80B H	83
ESB5200	2.00	280	227	170	708	197	8	8x8x15	140	1.75 70B H	82
ESB6225	2.25	315	251	188	783	218.3	8	8x12x15	140	2.00 45B	-
ESB7275	2.75	385	307	230	958	267.1	8	8x12x15	140	2.25 45B	-

NOTES:

- Add suffix "T" to denote boiler with tankless heater.
- I=B=R burner capacity is based on an oil heating value of 140,000 Btu/gal. and with 13% CO₂.
- Net ratings based on 170°F temperature in radiators and include 33% allowance for normal piping and pick-up load. Consult manufacturer for unusual piping and pick-up temperatures.
- For altitudes above 2,000 ft. ratings maybe reduced at the rate of 4% for every 1,000 ft. above sea level.
- Nozzle sizes with an H designation are Hago brand, all others are Delevan.
- The electrical service is 120 Volts, 15 Amps, 60 Hz.
- The MEA number for the ESB series is 182-86E.
- The MEA number for the AFG Beckett Burner used in the ESB series is 213-83-E.

DIMENSIONS (See FIG. A)

Boiler No.	Length of Flush Jacket	Front of Jacket to Center Line of Flue Outlet	Flue Outlet Diameter
	-A-	-B-	-C-
ESB-3S	16.375"	6.5"	6.0"
ESB-4S	20.25"	8.5"	6.0"
ESB-5S	23.875"	10.25"	7.0"
ESB-6S	27.5"	8.3125"	8.0"
ESB-7S	31.125"	8.3125"	8.0"

TANKLESS WATER HEATER CAPACITIES

Boiler Model Number	Firing Rate G.P.H.	Tankless Heater Number	Tankless Heater Capacity Intermittent Draw G.P.M.	Boiler Water	
				To Water Line	To LWCO Line
ESB0365	0.65	L-24	Available on request	11	8
ESB3100	1.00	L-24	4.5	11	8
ESB4125	1.25	L-24	4.5	13	9
ESB4150	1.50	L-24	4.5	13	9
ESB5175	1.75	L-24	5.0	15	10
ESB5200	2.00	L-24	5.0	15	10
ESB6225	2.25	L-24	5.0	17	11
ESB7275	2.75	L-24	5.0	19	12

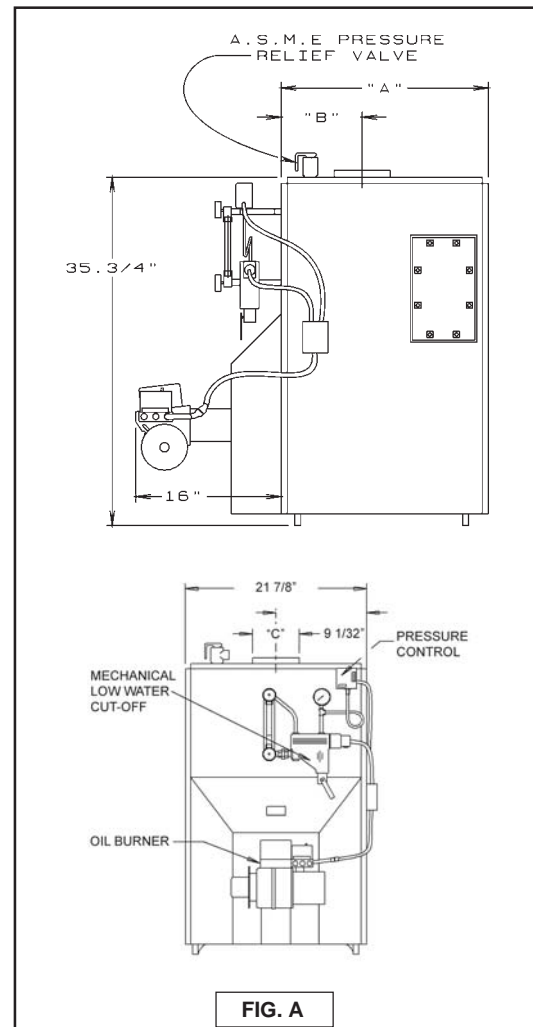

STANDARD EQUIPMENT: Crated boiler, flush jacket, oil burner, target wall/liner, ASME relief valve, steam water level gauge, steam pressure gauge, steam pressure control, mechanical low water cut-off, drain valve, wiring harness, burner electric disconnect, plastic cover, 2" supply tapping, 1½" return tapping, skim port, and primary control. (**NOTE:** For tankless heater units, add tankless hot water coil, and 4006 limit control.)

INSTALLATION PROCEDURE



Improper installation, adjustment, alteration, service or maintenance can cause injury or property damage.

All installations must conform to the requirements of the authority having jurisdiction. Such applicable requirements take precedence over the general instructions of this manual.

Where required by the authority having jurisdiction, the installation must conform to the American Society of Mechanical Engineers Safety Code for Controls and Safety Devices for Automatically Fired Boilers, ANSI/ASME No. CSD-1.

Locate boiler in front of final position before removing crate. Provide a level solid base as near chimney as possible and centrally located with respect to the heat distribution system as practical.



Boiler may not be installed on combustible flooring!!

Allow 24 inches in the front, top and right hand side for servicing and cleaning, or removing tankless water heating coil.

It is recommended that 24 inches be allowed in back of boiler for convenience when skimming hole is used.

When installed in a utility room, the door should be wide enough to allow the largest boiler part to enter, or to permit replacement of another appliance such as a water heater.

The boiler shall be installed such that the oil ignition system components are protected from water (dripping, spraying, rain etc.) during appliance operation and service.

FOR INSTALLATION ON NON-COMBUSTIBLE FLOORS ONLY - The boiler must not be installed on carpeting or vinyl flooring. Minimum clearances to combustible construction are:

- TOP 24 IN.
- FRONT 24 IN.
- FLUE CONNECTOR 9 IN.
- REAR 24 IN.
- LEFT SIDE 6 IN.
- RIGHT SIDE 24IN.

MINIMUM CLEARANCES TO COMBUSTIBLE CONSTRUCTION (AS SEEN FROM ABOVE)

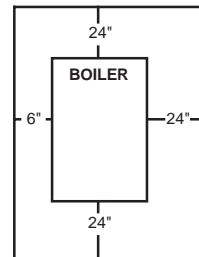

NOTE: Clearance for access should exceed fire protection clearance.

VENTILATION AND COMBUSTION AIR



Air openings to combustion area must not be obstructed. By following the instructions below, adequate combustion air can be maintained.

COMBUSTION AIR REQUIREMENTS

(Minimum Opening Requirement)

BTU/Hr Input	Unconfined Area*		Confined Area**	
	Outside	Inside	Outside Combustion Air	
	Combustion Air 1 Sq. In./5000 BTU/Hour (Step 4)	Combustion Air 1 Sq. In./1000 BTU/Hour (Min. 100 Sq. In.) (Fig. 1)	Vertical Ducts 1 Sq. In./4000 BTU/Hour (Fig. 2 & 3)	Horizontal Ducts 1 Sq. In./2000 BTU/Hour (Fig. 4)
91,000	19	100	23	46
140,000	28	140	35	70
175,000	35	175	44	88
210,000	42	210	53	106
245,000	49	245	61	122
280,000	56	280	61	140

* A space whose volume is not less than 50 cubic feet per 1000 BTU/Hour of all appliances installed in that space (cubic feet of space = height x width x length)

** A space whose volume is less than 50 cubic feet per 1000 BTU/Hour of all appliances installed in that space (cubic feet of space = height x width x length)

1. Ventilation of boiler room must be adequate enough to provide sufficient air to properly support combustion and venting.

2. When the boiler is located in an unconfined space in a building of conventional construction frame, masonry or metal, infiltration normally is adequate to provide air for combustion and ventilation. However, in any building which has been altered to conserve energy or to minimize infiltration, the boiler area should be considered as a confined space. If there is any doubt, install air supply provisions for combustion and ventilation in accordance with section 5.3, Air for Combustion and Ventilation, of the NFPA 54 1988 code, the recommendations that follow, or applicable provisions of the local building codes.

3. When the boiler is installed in an unconfined space, in a building of unusually tight construction, air for combustion and room ventilation must be obtained from outdoors or from spaces freely communicating with the outdoors. A permanent opening or openings having a total free area of not less than 1 square inch per 5,000 BTU per hour of total input rating of all appliances shall be provided. Ducts may be used to convey make-up air from the outdoors and shall have the same cross-sectional area of the openings to which they are connected.

4. When air for combustion and room ventilation is from inside buildings, the confined space shall be provided with two permanent openings, one starting 12 inches from the top and one 12 inches from the bottom of the enclosed space. Each opening shall have a minimum free area of 1 square inch per 1,000 BTU per hour of the total input rating of all appliances in the enclosed space, but must not be less than 100 square inches. These openings must freely communicate with the interior areas having adequate infiltration from the outside. (Figure 1)

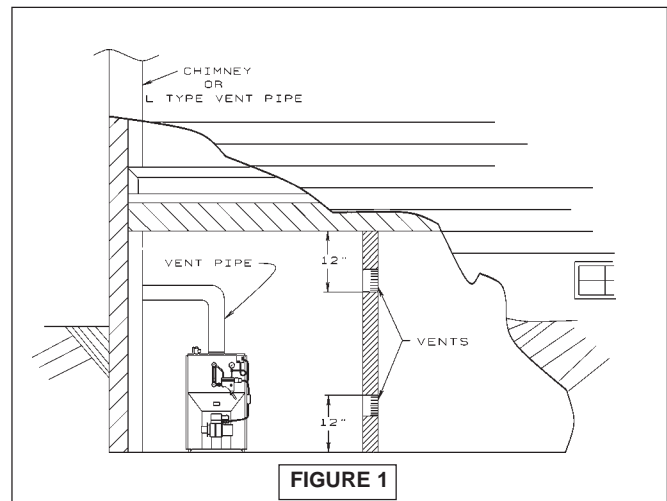

5. When the boiler is installed in a confined space and all air is provided from the outdoors, the confined space shall be provided with two permanent openings, one commencing within 12 inches from the top and one commencing 12 inches from the bottom of the enclosure. The openings shall communicate directly, or by ducts, with the outdoors or spaces (crawl or attic) that freely communicate with the outdoors. One of the following methods must be used to provide adequate air for ventilation and combustion.

A. When directly communicating with the outdoors, each opening shall have a minimum free area of 1 square inch per 4,000 BTU per hour of total input rating of all equipment in the enclosure. (Figure 2)

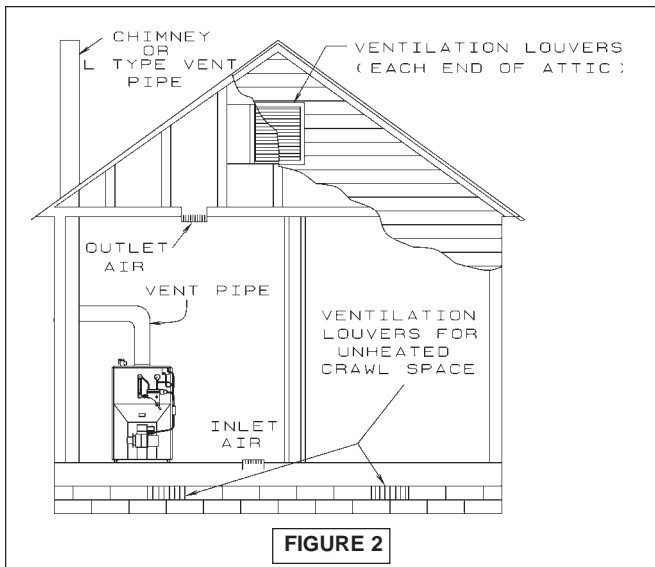

B. When communicating with the outdoors by means of vertical ducts, each opening shall have a minimum free area 1 square inch per 4,000 BTU per hour of total input rating of all appliances in the enclosed space. (Figure 3)

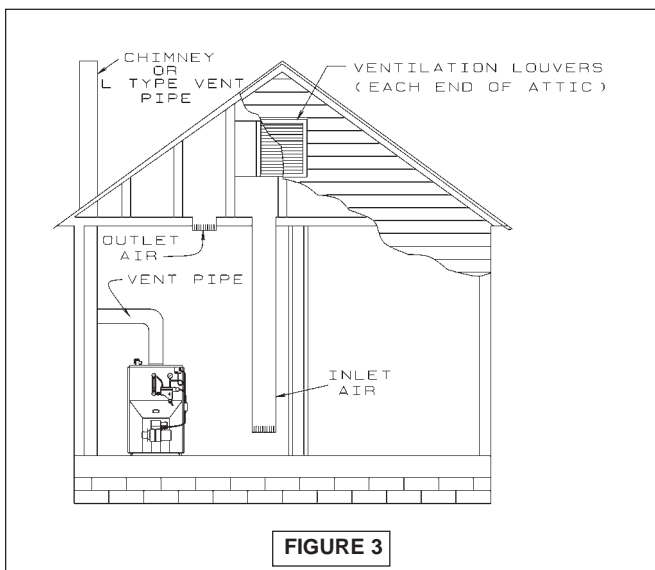

C. If horizontal ducts are used, each opening shall have a minimum free area 1 square inch per 2,000 BTU per hour total input rating of all appliances in the enclosed space. (Figure 4)

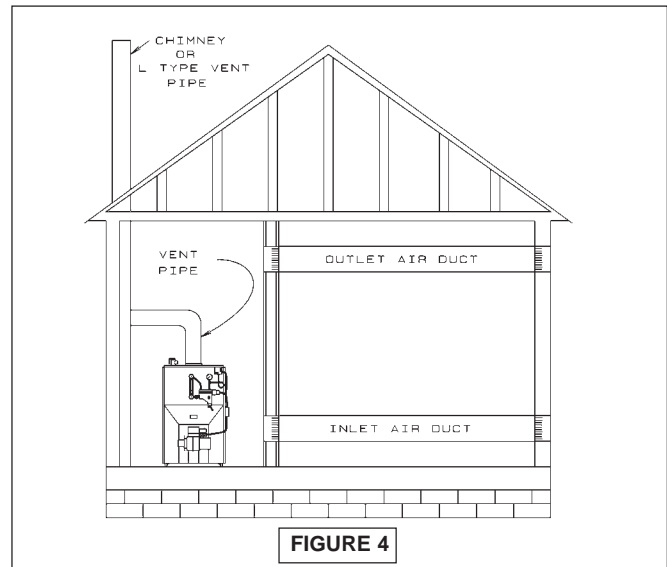

D. When ducts are used, they shall be of the same cross sectional area as the free area of the area of the openings to which they connect. The minimum dimension of rectangular air ducts shall not be less than 3 inches.

6. In calculating free area using louvers, grills or screens for the above, consideration shall be given to their blocking effect. Screens used shall not be smaller than 1/4 inch mesh. If the free area through a design of louver or grill is known, it should be used in calculating the size opening required to provide the free area specified. If the design and free area is not known, it may be assumed that wood louvers will have 20-25% free area and metal louvers and grills will have 60-75% free area. Louvers and grills shall be fixed in the open position or interlocked with the boiler so that they are opened automatically during boiler operation.

CONNECTING SUPPLY AND RETURN PIPING

1. Suggested piping for steam heating system can be seen in Figure 5. Actual piping may vary based on system design and local conditions.

2. For further piping information refer to the I=B=R installation piping guide.

3. See Figure 6 for typical piping for domestic hot water heater.

4. See Figures 7 and 8 for the suggested piping for a modular steam boiler.

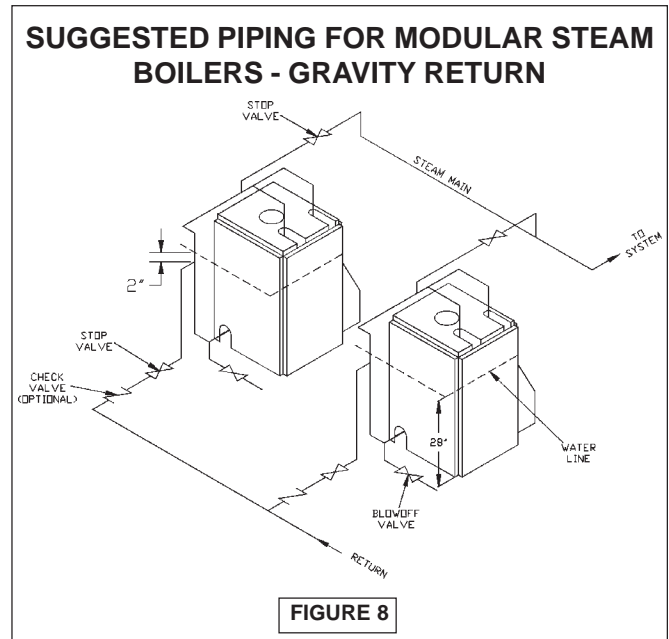
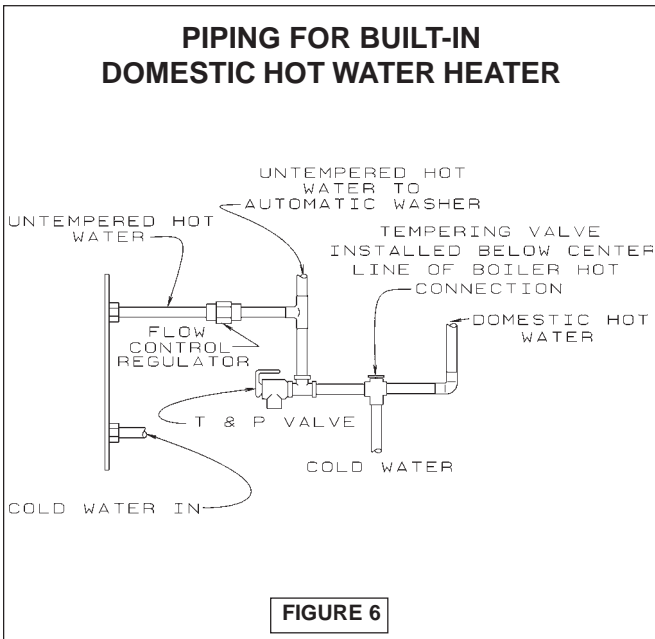
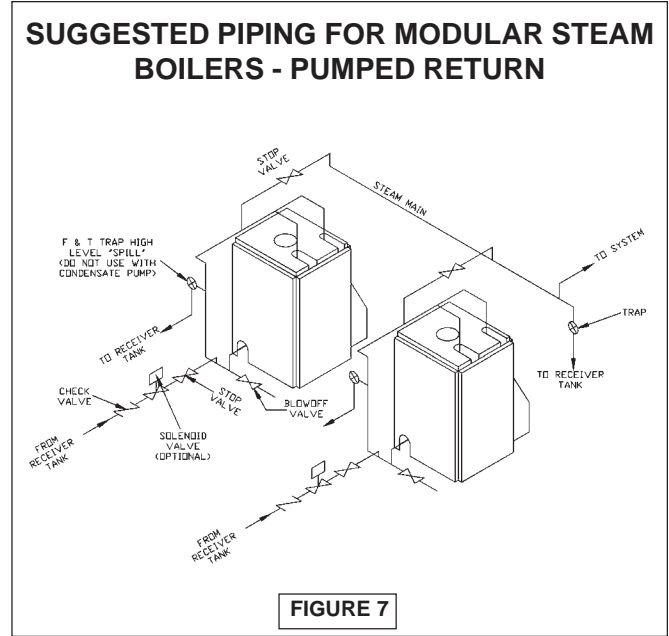
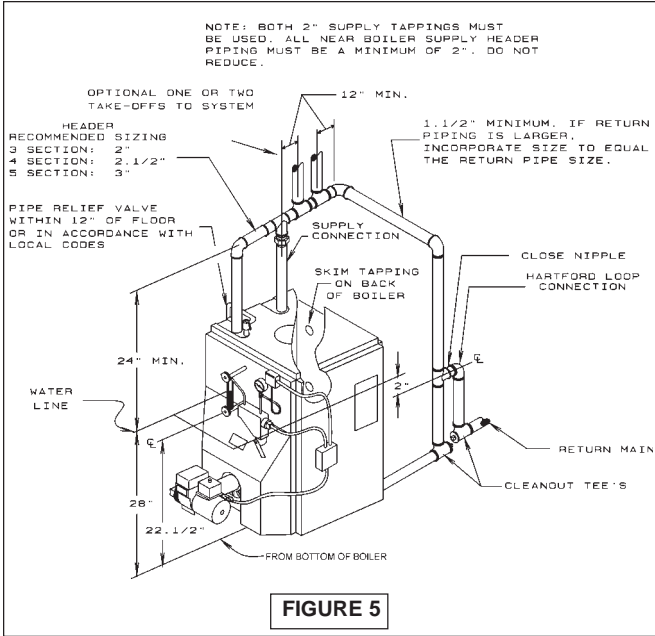

VENTING SYSTEM INSPECTION & INSTALLATION



WARNING

Boiler is to be vented by natural draft and shall not be connected into any portion of a mechanical draft operating system under a positive pressure.

Inspect chimney to make certain it is constructed according to the latest revision of the NFPA 211. Local regulations may differ from this code and should be checked. Where there is a conflict, the local code will prevail.

The boiler must be installed into a chimney which has a masonry or metallic chimney liner.

An unlined chimney will have leaks that will cause poor chimney performance (no draft), and could result in a positive pressure in the combustion chamber.

Horizontal portions of the venting system should not exceed 10 feet in length. Horizontal lengths over 10 ft. will have a negative effect on the chimney performance.

The chimney should extend at least 2 ft. above any portion of the building within 10 ft. (Figure 9) It should produce a -.02 inch W.C. draft in the combustion chamber. See "Chimney or Vent Sizes" chart for recommended minimum and maximum chimney or vent sizes.

Inadequate draft will cause improper combustion, resulting in dirty flue ways and high fuel bills.

Connect flue pipe same size as boiler outlet to chimney, sloping upward continuously toward the chimney approximately 1/4" per foot. Bolt or screw joints together to avoid sag.

If an oil fired water heater is vented into the same flue as the boiler, provide a separate hole into the chimney whenever possible. When this isn't possible, use a "Y" connection in the flue pipe, using a separate draft regulator for each unit. When a chimney will not provide adequate draft to handle the input from the water heater and boiler simultaneously, wire the units so that only one will operate at a time, favoring the water heater.

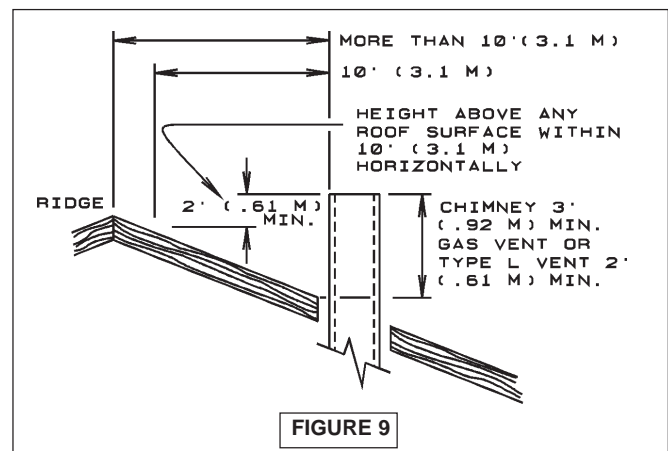

FIGURE 9

CHIMNEY OR VENT SIZES

BTU/HR INPUT	ROUND INCHES		SQUARE INCHES		HEIGHT (FT)	
	MIN	MAX	MIN	MAX	MIN	MAX
91,000 - 140,000	6	8	8x8	8x8	15	40
175,000 - 210,000	7	8	8x8	8x10	15	40
245,000 - 280,000	8	10	8x8	8x12	15	50
315,000	8	10	8x8	8x12	15	50
385,000	8	10	8x8	8x12	15	50

OIL TANK AND PIPING

Oil tank and piping should be installed in accordance with the National Board of Fire Underwriters and local regulations. Oil storage tank, vent, fill pipe and caps should be as prescribed by local codes. In no case should the vent pipe be smaller than 1-1/4" I.P.S. The fill pipe should not be less than 2" I.P.S.

The suction line from the tank to the burner should be one continuous piece of tubing to prevent air entering the line. The suction line, must be 3/8" O.D. copper tubing for runs of 50 feet or less, and 1/2" O.D. for longer runs. An oil return line, same size as

the suction line, must be used on any installation where the bottom of the tank is below the fuel unit of the burner. Oil lines should be buried or otherwise protected from mechanical injury. Flare fittings on all oil lines are recommended. Compression fittings on the suction line often allow air to be drawn into the fuel pump, making it difficult to maintain oil pressure at the nozzle. Do not run overhead fuel lines from tank to oil burner.

Fuel pump connections and by-pass should be made according to instructions attached to the fuel pump.

If tank is more than 20' from the boiler, a two stage fuel unit should be installed in place of the single stage pump supplied as standard equipment with the burner. Make certain the rotation and speed are the same and the pump is suitable for the burner horsepower rating.

An oil line filter and shut-off valve should be installed in the suction line. Shut-off valves should be installed in both the suction and return lines at the burner for convenience in servicing burner. Allow extra tubing at burner so burner may be removed from boiler for cleaning without disconnecting tubing. (Figures 10-11) An optional flexible oil line is available.

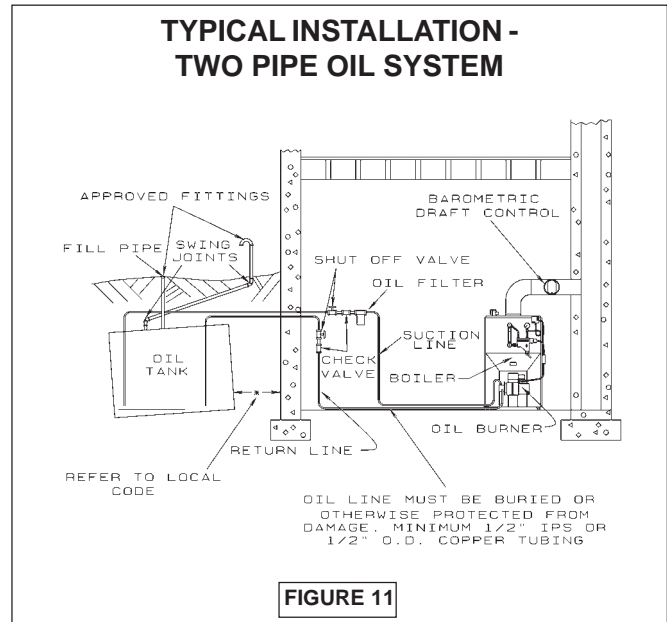
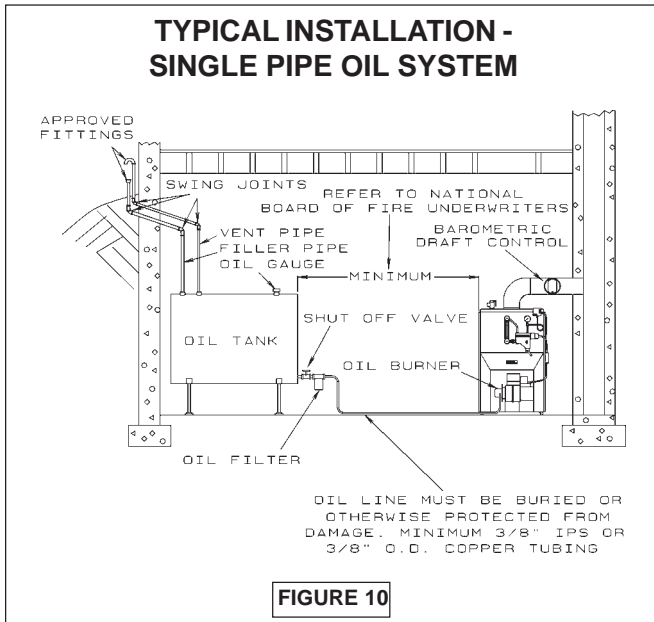

ELECTRICAL WIRING

Electrical wiring must conform with the latest revisions of the National Electrical Code, ANSI/NFPA No. 70, and/or local authority having jurisdiction.

1. When an external electrical source is utilized, the boiler, when installed, **MUST BE** electrically grounded in accordance with these requirements.

2. Install a fused disconnect switch between boiler and meter at a convenient location.

3. When the boiler is equipped with self-energized controls, no outside source of electric power shall be connected to the circuit of this system. (See "Steam Wiring W/MM #67 Mechanical LWCO" on next page.)

THERMOSTAT INSTALLATION

1. Thermostat should be installed on an inside wall about four feet above the floor.

2. **NEVER** install a thermostat on an outside wall.

3. Do not install a thermostat where it will be affected by drafts, hot or cold pipes, sunlight, lighting fixtures, television, fireplaces, or chimneys.

4. Check thermostat operation by raising and lowering thermostat as required to start and stop the burner.

5. Instructions for the final adjustment of the thermostat are packaged with the thermostat (adjusting heating anticipator, calibration, etc.).

STEAM WIRING W/MM #67 MECHANICAL LWCO

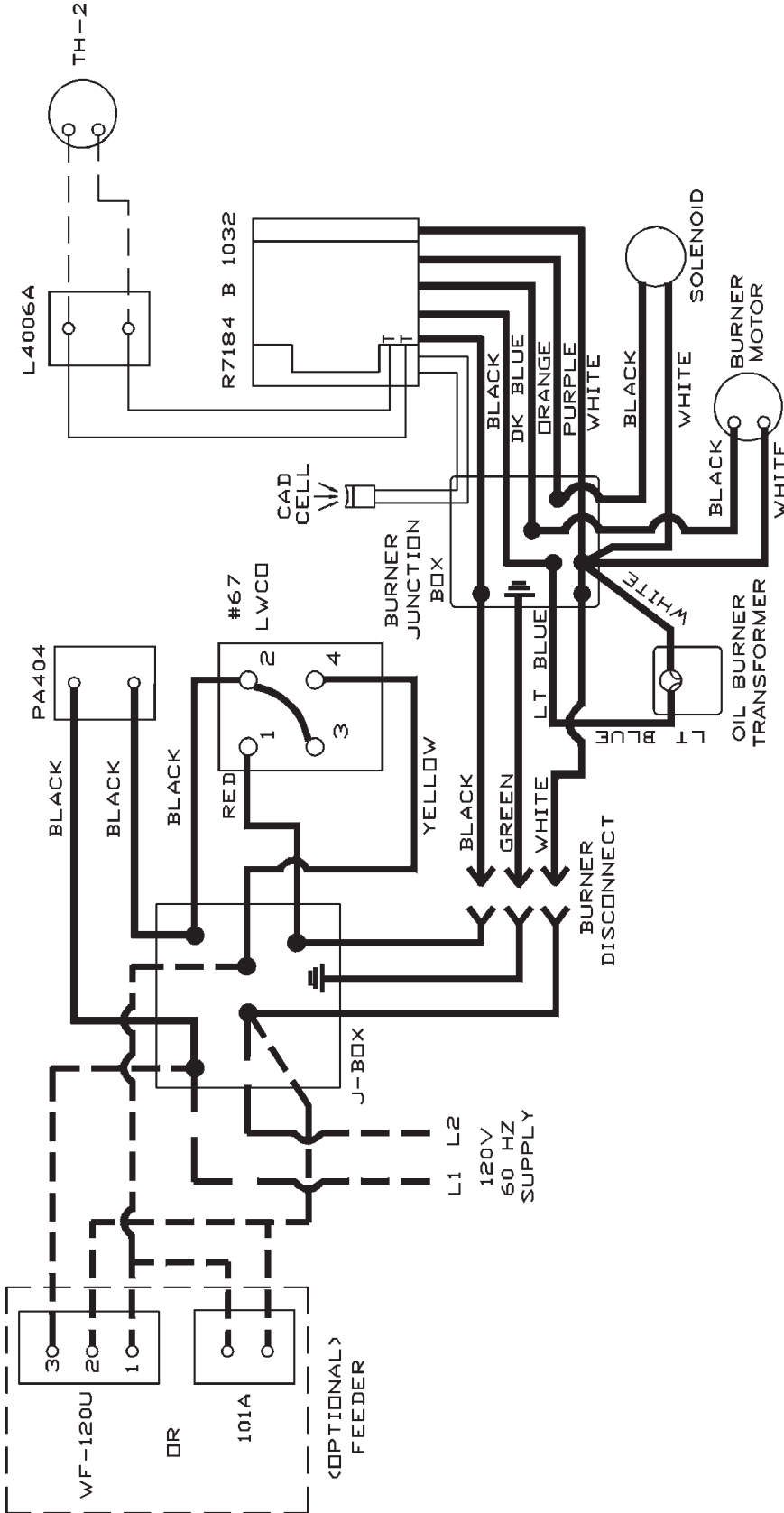

COMPONENT CODING

Component	MR-PS	Manual Reset Pressure Switch	CIR
TH-1	Thermostat (Millivolt)	Control Terminal	Circulator
TH-2	Thermostat (24 Volt)	Relay Coil	Energy Cut-Off
TH-3	Thermostat (Line Voltage)	Relay Contacts	Pilot Safety Coil
TR-1	Transformer (120V/24V/40VA)	Relay Contacts	Wire Connection
TR-2	Transformer (120V/24V/50VA)	Relay Contacts	Low Water Cut Off
LGV24	Volt Gas Valve	Limit Switch	Electric Water Feeder
PS	Pressure Switch	Manual Switch	Power Generator

WIRING CODE

—	Line Voltage By Factory
---	Low Voltage By Factory
---	Line Voltage By Installer
---	Low Voltage By Installer

NOTE: Not all components listed are used in all control systems.

NORMAL SEQUENCE OF OPERATION

On a call for heat, the thermostat will actuate, completing the circuit to the boiler. In turn, the ignition systems are activated and ignition will begin.

In the event of a low water condition, an automatic low water cut-off device will interrupt power between the low water cut-off and the burner. The burner will remain off until the low water condition is corrected, (i.e., manually restore boiler water or utilize a water feeder device which will automatically restore water to its normal operating level).

IMPORTANT TO THE INSTALLER - Before putting the boiler in operation, test the mechanical low water cut-off device for proper operation. While burner is on, open the blow-off valve located in the lower portion of the cut-off body. This will drain the water quickly from the cut-off body and break the circuit to the burner. If it does not, replace control.



WARNING

WATER WILL BE BOILING HOT.

OPERATING INSTRUCTIONS

The venting system should be inspected at the start of each heating season. Check the vent pipe from the boiler to the chimney for signs of deterioration by rust or sagging joints. Repair if necessary.

Remove the vent pipe at the base of the chimney or flue and, using a mirror, check for obstruction and verify compliance to the latest revision of the NFPA 211.

The lever of the pressure relief valve (*Figure 12*) on the boiler should be operated periodically to make sure that it is functioning properly.

The pressure relief valve should open before the steam pressure exceeds the 15 lb. reading on the gauge. If this pressure is exceeded and the pressure relief valve leaks steam when the boiler is operating at normal pressures, it should be immediately replaced. Corrosion can build up rapidly at the valve seat and prevent its functioning as a safety device.

START-UP AND ADJUSTMENT OF OIL BURNER

(See oil burner instructions for nozzle and electrode setting).



CAUTION

DO NOT SET FIRE VISUALLY.

Instruments are the only reliable method to determine proper air adjustments. An improperly adjusted burner causes soot and high fuel bills because of incomplete combustion of the fuel oil. This in turn may require excessive boiler maintenance, service costs, and in some instances, house cleaning or redecorating. A competent service mechanic should be consulted to make the proper adjustments with a smoke tester, CO₂ indicator, and draft gauge. NOTE: Bacharach or Dwyer test kits include these instruments.

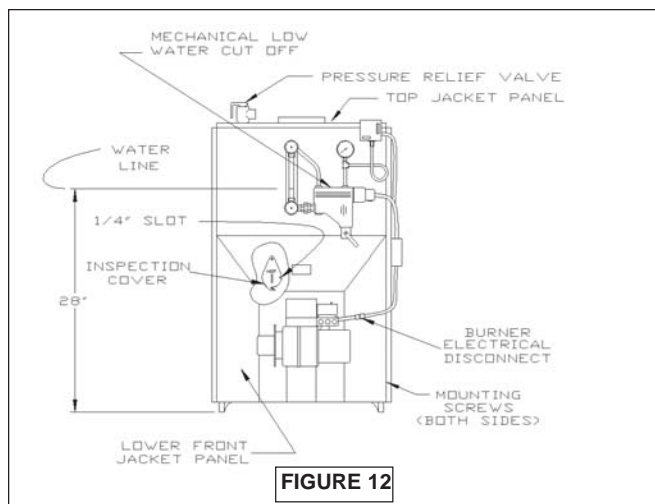

WARNING

Discharge will be boiling hot water and steam.

A. Check oil burner nozzle to make certain it is tight in adapter. Burner mounting bolts should be tight.

B. Check electrode setting, as they may have been jarred out of position during transportation.

C. Lubricate burner motor if necessary.

D. Set room thermostat to call for heat, or jump thermostat contacts on the boiler control.

E. Open all oil line valves.

F. Turn service switch on. Burner should start.

G. On one pipe fuel systems only, bleed pump as soon as burner starts. Allow oil to run until all traces of air in the suction line disappear.

H. Turn "OFF" burner and install pressure gauge port on pump.

I. Start burner again and check oil pressure for 140 lbs. Adjust if necessary.

INSTRUCTIONS TO OBTAIN PROPER OPERATION OF BOILER-BURNER UNIT

A 1/4" diameter slot is provided in the inspection cover plate to take draft readings in the combustion chamber. (Figure 12) A 1/4" diameter hole will be required in the flue pipe between the boiler and barometric damper (if used) to take draft, CO₂, smoke and temperature readings. Adjust air shutter on oil burner to obtain a "trace" of smoke. Measure CO₂ at this point. Increase air adjustment to lower CO₂ approximately one percent. Check to insure minimum negative .02 w.c., (water column), "overfire" draft and zero smoke. If -.02 w.c. "overfire" draft can not be maintained, changes and/or modifications may be required in the venting or the chimney.

The following tables are provided as a guideline for initial start-up. Final adjustments MUST be made using combustion instruments as previously mentioned.

RIELLO SETTINGS

Boiler No.	Burner No.	Air Damper	Pump Press.	Turb.	Nozzle Furnished
ESB3100	F-5	3.6	150 PSI	1	.85 80W
ESB4125	F-5	4	150 PSI	3	1.10 60W
ESB4150	F-5	6	150 PSI	4	1.25 60W
ESB5200	F-10	5	150 PSI	0	1.75 80B

CARLIN SETTINGS

Boiler No.	Burner No.	Air Damper	Pump Press.	Head Bar	Nozzle Furnished
ESB3100	EZ-1	0.85	150 PSI	.85-1.00	.85 70B
ESB4125	EZ-1	1.00-1.10	150 PSI	1.10-1.25	1.10 70B
ESB4150	EZ-1	1.25-1.35	150 PSI	1.10-1.25	1.25 70B
ESB5200	EZ-2	1.75	150 PSI	1.65-1.75	1.75 70B

BECKETT SETTINGS

Boiler No.	Burner No.	Air Damper	Air Shut.	Pump Press.	Static Disc	End Cone	Nozzle Furnished
ESB3100	AFG	1	5	140 PSI	3-3/8U	F3	.85 80B
ESB4125	AFG	1	8	140 PSI	2-3/4"	F4	1.10 80B
ESB4150	AFG	2	6	140 PSI	2-3/4"	F6	1.25 80B
ESB5200	AFG	5	5	140 PSI	3U	F12	1.75 70B H
ESB6225	CF375	4	6	140 PSI	L1	N/A	2.00 45B
ESB7275	CF375	4	6	140 PSI	L1	N/A	2.25 45B

NOTES:

(1) Model ESB6225 needs a head setting of 1 and ESB7275 needs a head setting of 2.

(2) Nozzle sizes with an H designation are Hago brand, all others are Delevan.

(3) Information in above table uses Beckett model AFG burner for model numbers ESB365-5200 and Beckett model CF375 for model numbers 6225 and 7275.

IMPORTANT: Check safety control circuit after burner adjustments have been made for satisfactory performance.

A. Pressure Control - Remove cover and note pressure setting. With boiler operating, decrease the setting. When the setting is lower than boiler pressure, the control will open and turn off the boiler. After checking pressure control, reset control to original setting.

B. Mechanical Low Water Cut-off - May be checked by opening the blow-off valve on the lower portion of the cut-off body while the boiler is running. This will drain the water from the boiler and break the circuit to the burner.



WARNING

WATER WILL BE BOILING HOT.

Refill boiler to its normal water line.

C. Primary Control and Flame Sensor -

To Check:

1. Flame Failure - simulate by shutting off oil supply with hand valve while burner is on. Sixty seconds after flameout, the safety switch locks out, ignition stops, motor stops and oil valve - when used - closes. To restart, open oil supply valve and reset safety switch.
2. Ignition Failure - With burner off, close oil supply valve and run through start-up procedure, The safety switch should lock out as in flame failure.
3. Power Failure - Turn off main power supply switch while burner is operating. When burner stops, restore power and burner should start. If operation is not as described as above, check wiring and controls.

Preventative maintenance of an oil fired boiler reduces operating costs. The boiler and vent pipe should be inspected for accumulation of soot or scale deposits periodically but at least once every year before the start of each heating season. When soot is present on the section walls and flueways, improper combustion will result, causing additional sooting and scaling until flueways are completely closed. To remove soot and scale from the flueways, remove top jacket panel, top clean-out plate, open burner swing door. (Figure 12)

OPENING THE BURNER SWING DOOR

1. Turn off power to boiler and allow boiler to cool down.

2. Disconnect power cable at factory supplied burner electrical disconnect. (Figure 12)

3. Loosen screws on the sides of the lower front jacket panel. (Figure 6) Pull the bottom part of the lower front panel forward and lift the lower front panel up and off the boiler. (Figure 12)

4. Close oil valve (Figures 10-11) and disconnect oil line from burner.

IMPORTANT: Do not open swing door with oil line attached.

5. Remove nut from swing door stud on right hand side of door.

6. Swing open burner and door to the left. Using a flue brush, brush the soot and scale into the combustion space where it can be removed through the swing door opening.



CAUTION

Use caution when vacuuming in the chamber area. Damage to chamber could result.

It is recommended to replace the nozzle at the start of each heating season. Lubricate the burner motor and circulator motor - if required - with a few drops of a good grade of light motor oil. Do not over oil. Have a competent service person service the burner and check the controls and check the electrodes for carbon or cracks in the insulators. Burners should be adjusted to produce the conditions shown in "Startup and Adjustment of Oil Burner."

CLOSING THE BURNER SWING DOOR

1. Swing burner and door to the right until insulation is slightly compressed and the stud is exposed.
2. Attach nut to the stud and tighten it until the built in stop contacts the mounting door.
3. Reconnect oil line to burner.
4. Replace lower jacket panel, and tighten the screws.
5. Connect the power cable at the factory supplied burner electrical disconnect.
6. Turn on power to boiler and bleed oil line.

MAINTENANCE PROCEDURES

Before seasonal start up it is advisable to have a competent service agency check the boiler for soot and scale in the flues, change oil filter and nozzle, clean the burner and readjust burner input rate to maintain high operating efficiency.

On steam boilers make certain the boiler is filled to the water line as indicated in Figure 12. The gauge cocks should be normally open. To remove dirt from the gauge glass the petcock may be opened to flush out the glass.



Discharge may be boiling hot water.

The radiator valves on a one-pipe steam system must be either wide open or tightly shut. Do not attempt to regulate room temperature by partially closing the radiator valve.

Air vents on steam radiators and the supply main release air from the system. If radiators do not heat satisfactorily, make sure the air vents are clean and operational.

The lever of the pressure relief valve on the boiler (Figure 12) should be operated periodically to make sure that it is functioning properly.



Discharge will be boiling hot water and steam.

The safety valve should open before the steam pressure exceeds the 15 lb. reading on the gauge. (Figure 12) If this pressure is exceeded and the safety valve does not open, it must be replaced. If the safety valve leaks steam when the boiler is operating at normal pressures, it should be immediately replaced. Corrosion can build up rapidly at the valve seat and prevent its functioning as a safety device. If the water in a steam boiler appears to be dirty or oily, or the water level in the gauge glass fluctuates considerably, the boiler should be cleaned. A competent service person will use approved cleaning compounds and properly clean and flush out the boiler. He/she should also clean or replace air vents and traps, clean flue passages and check for proper operation of all controls and safety devices.

The venting system should be inspected at the start of each heating season. Check the vent pipe from the boiler to the chimney for signs of deterioration by rust or sagging joints. Repair if necessary.

Impurities in boiler water of a steam boiler may cause foaming and an unsteady water line, or prevent steam generation. They may result in objectionable odors escaping from the vents on water boilers. This condition is caused by oil, grease, and sediment from pipe fittings collecting within the boiler and can be remedied only by giving the boiler a thorough cleaning.

BOILERS SHOULD BE CLEANED BY SKIMMING OR BLOWING DOWN.



The boiler should not be left unattended during the cleaning process.

SKIMMING OFF IMPURITIES

Some of the impurities in the boiler water will float on the water and must be skimmed off.

With the boiler empty and cool, slowly begin to add water. After water has entered boiler - never before - turn "on" oil burner and adjust water flow so that the water being added is kept just below boiling point. Avoid boiling and turbulence.

Gradually raise hot water level to skimming hole (Figure 6) installed on the rear section of the boiler being careful not to raise it above the opening of the hole. Skim until there are no impurities. Repeat the process if necessary.

Water may be checked to make sure it is free from oil by drawing off a sample at the skimming hole. If the sample is reasonably free from oil, it will not froth when boiled on stove. This test does not indicate the amount of sediment which may lay in the bottom of the boiler. It is therefore necessary that the boiler be further cleaned by "blowing down."

BLOWING DOWN THE BOILER

Before blowing down the boiler, fill it to the water line. Turn on burner and allow five pounds of steam

pressure to build up. Run a temporary connection from one of the drain valves to a nearby sewer. Connect to a drain valve on the opposite end of the boiler from feed water inlet, if possible. Shut off the oil burner, open drain valve and blow down the entire contents of boiler.

Allow boiler to thoroughly cool and slowly refill to water line. Repeat as many times as required until blow off water is clear. Owner should blow down boiler at least once each month of the heating season.



WARNING

WATER WILL BE BOILING HOT.

USING CLEANING COMPOUND

If an exceptional amount of dirt or sludge seems to be present in the boiler, a boiler cleaning compound made by a reputable manufacturer may be used according to the instructions of the manufacturer of the compound. When any type of cleaning compound is used, care must be taken to thoroughly flush all traces of the compound out of the boiler.

Following blow down allow the boiler to cool. Add fresh water slowly. Be certain to blow enough times as required to remove compounds from system.

The area around the boiler must be kept clear and free of combustible materials, gasoline and other flammable vapors and liquids.

The free flow of combustion and ventilation air to the boiler and boiler room must not be restricted or blocked.

Periodic inspection and tightening of the tankless heater/cover plate bolts will reduce the risk of leaks. See parts 3 and 5 under "Coil and Cover Plate Replacement Parts."

MECHANICAL LOW WATER CUT-OFF

Operation should be checked, with burner on, by opening the blow-off valve located in the lower portion of the low water cut-off body. This will drain the water quickly from the cut-off body and break the circuit to the burner. If it does not, replace the control.

During the heating season, the blow-off valve on the low water cut-off should be opened once a week to flush out the sediment chamber so the device will be free to function properly. (Figure 12) Use a pail to catch the discharge.



WARNING

WATER WILL BE BOILING HOT.

It is suggested that a qualified service agency be employed to make an annual inspection of the boiler and heating system. They are experienced in making the inspections outlined above and, in the event repairs or corrections are necessary, can make the proper changes for safe operation of the boiler.

REPLACEMENT PARTS - COIL AND COVER PLATE

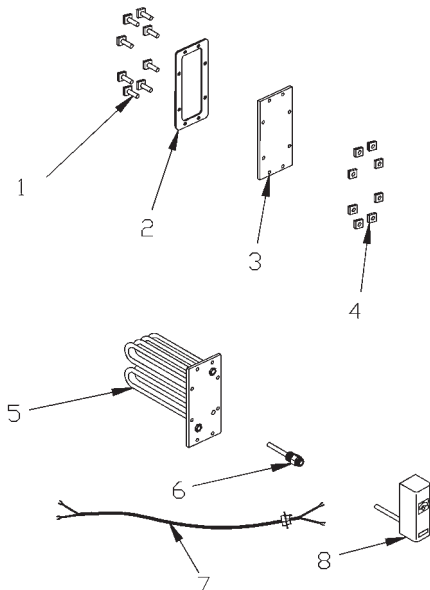

ITEM	PART NO.	DESCRIPTION	QTY.
1	HW-012.02	Bolt - 7/16-14x1½ Square Head	8
2	252-2-2.00	Gasket - B Tankless	1
3	202-2-1.00	Cover Plate - B Tankless Coil	1
4	HW-013.01	Nut 7/16-14 Square	8
5	252-3-1.02	Tankless Coil L-24	1
6	AQ-020.03	Well ¾ x 1½ - 123870A	1
7	275-1-1.00	Harness	1
8	AQ-008.00	Control - L4006A1827	1

REPLACEMENT PARTS - CONTROLS AND HARDWARE

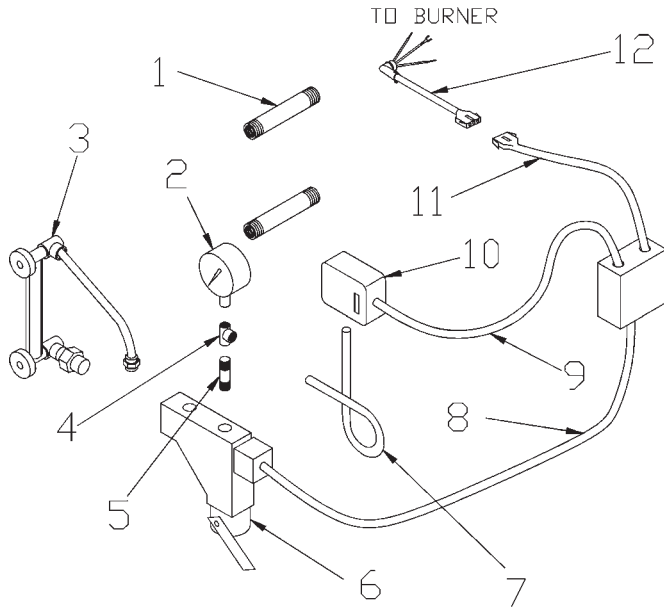

ITEM	PART NO.	DESCRIPTION	QTY
1	PF05501	Pipe Fit - Nipple ½" x 2" Brass	2
2	GA-003.00	Gauge Pressure (Steam)	1
3	GA-004.00	Gauge - Water Level	1
4	PF-025.01	Pipe Fit Tee ¼"	1
5	PF-026.05	Pipe Fit Nipple ¼" x 3"	1
6	WC-011.00	MLWCO #67-CH-3 24 Volt	1
	275-2-3.01	LWCO Assembly Steam*	1
7	753-1-3.00	Siphon 90° Black Iron	1
8	28511301	Harness ELWCO 24"	1
9	28511201	Harness Pressure Switch 30"	1
10	SS-001.01	Pressure Switch PA404A-1009	1
11	1263012	Harness Burner 22" (Beckett & Riello)	1
	28511801	Harness Aquastat 41" (Carlin)	
12	1263013	Burner Harness 8" (Beckett)	1
	1263011	Burner Harness 8" (Riello)	
	28511901	Burner Harness 8" (Carlin)	

* This includes MLWCO #2, 4, 5, 7, 8, 9, & 10

REPLACEMENT PARTS - HARDWARE

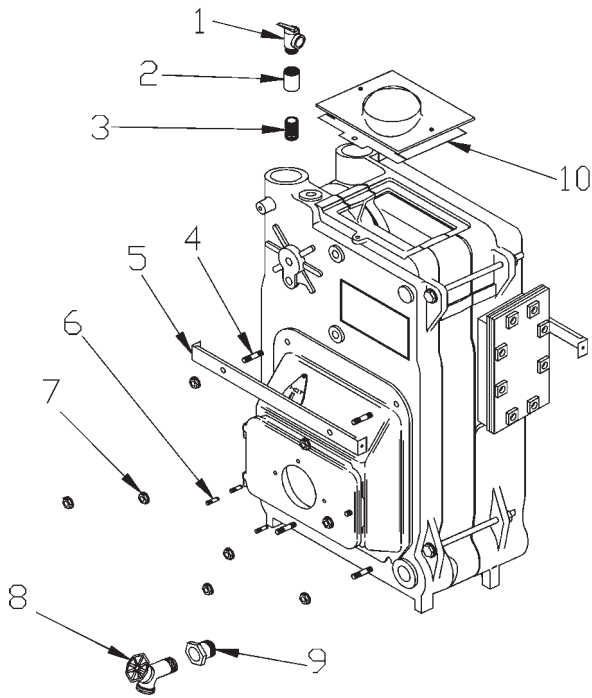

ITEM	PART NO.	DESCRIPTION	QTY
1	VR-002.02	Relief Valve #15 ¾"	1
2	PF-019.02	Pipe Fit Coupling ¾"	1
3	PF-005.01	Pipe Fit Npl ¾" Close	1
4	HW06701	Stud 5/16-18 x 2-3/8"	4
5	2252501	Support - Jacket Brkt	2
6	HW07001	Stud 5/16" x 18 x 1-3/8"	3
7	HW06901	Nut 5/16"-18 Wislock	8
8	HW-016.02	Drain	1
9	PF-004.04	Pipe Fit Bushing 1¼ x ¾"	1
10	2452906	Flue Collector - 3 Sec.	1
	2452902	Flue Collector - 4 Sec.	
	2452903	Flue Collector - 5 Sec.	
	2452907	Flue Collector - 6 Sec.	
	2452908	Flue Collector - 7 Sec.	

REPLACEMENT PARTS - HEAT EXCHANGER

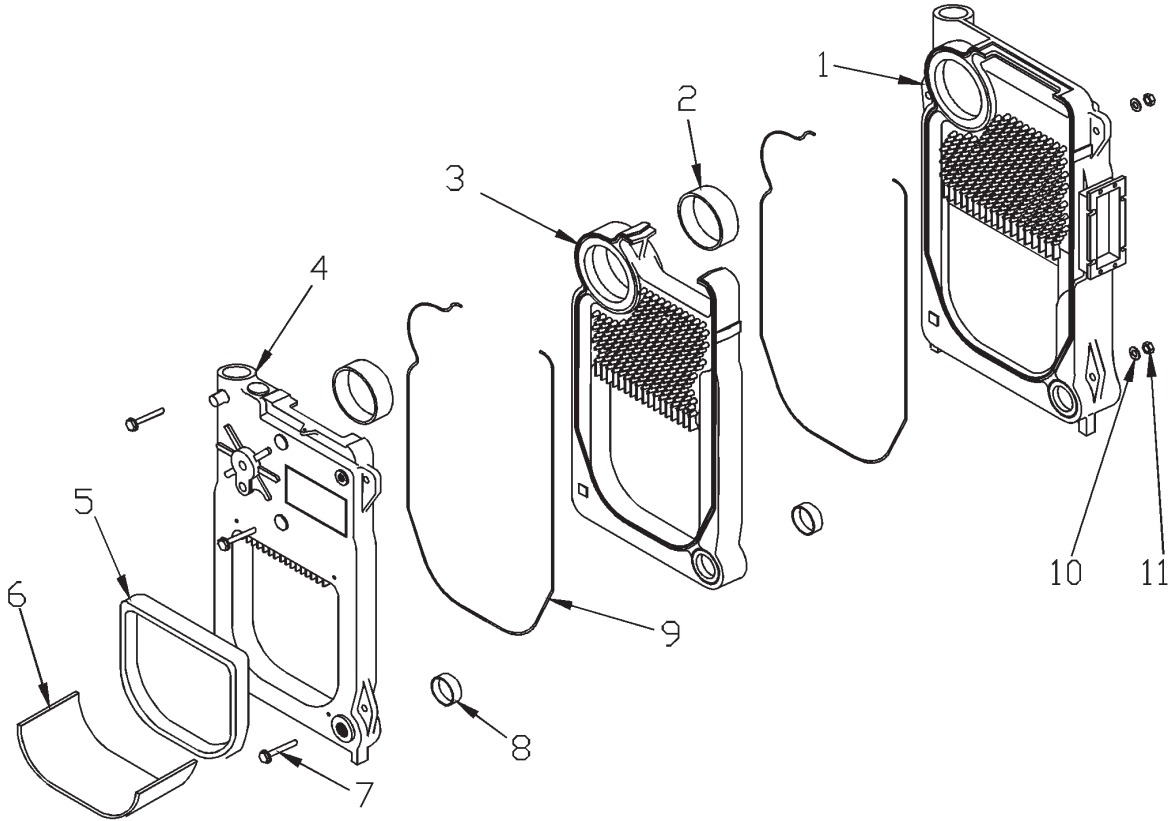

ITEM	PART NO.	DESCRIPTION	QTY
1	100-5-10.01	Rear Section	1
2	100-1-8.01	#60 Push Nipple - 3 Sec.	2
		#60 Push Nipple - 4 Sec.	3
		#60 Push Nipple - 5 Sec.	4
		#60 Push Nipple - 6 Sec.	5
		#60 Push Nipple - 7 Sec.	6
		3	10051101
Center Section - 4 Sec.	2		
Center Section - 5 Sec.	3		
Center Section - 6 Sec.	4		
Center Section - 7 Sec.	5		
4	10051202	Front Section Castover	1
5	5611508	Kit - Target Wall & Insulation Blanket	1
6	25511005	Insul Blanket 16x24 (6 & 7 Section)	1
7	HW-025.05	Tie Rod ½ x 9 - 3 Sec.	3
	HW-025.01	Tie Rod ½ x 12½ - 4 Sec.	
	HW-025.02	Tie Rod ½ x 16½ - 5 Sec.	
	HW-025.03	Tie Rod ½ x 20½ - 6 Sec.	
	HW-025.09	Tie Rod ½ x 23½ - 7 Sec.	
8	100-1-5.01	#22 Push Nipple - 3 Sec.	2
		#22 Push Nipple - 4 Sec.	3
		#22 Push Nipple - 5 Sec.	4
		#22 Push Nipple - 6 Sec.	5
		#22 Push Nipple - 7 Sec.	6

ITEM	PART NO.	DESCRIPTION	QTY
9	MS-006.00	Rope, Med. Density - 3 Sec.	13.0'
		Rope, Med. Density - 4 Sec.	19.5'
		Rope, Med. Density - 5 Sec.	26.0'
		Rope, Med. Density - 6 Sec.	32.5'
		Rope, Med. Density - 7 Sec.	39.0'
10	HW-008.03	Washer ½ ID Flat	3
11	HW-003.05	Nut ½-13 Hex Head	3

FULLY ASSEMBLED HEAT EXCHANGERS		
10022201	3 Section Without Coil	
10022202	4 Section Without Coil	
10022203	5 Section Without Coil	
10022207	6 Section Without Coil	
10022208	7 Section Without Coil	
10022204	3 Section With Tankless Coil	
10022205	4 Section With Tankless Coil	
10022206	5 Section With Tankless Coil	
10022209	6 Section With Tankless Coil	
10022210	7 Section With Tankless Coil	

REPLACEMENT PARTS - JACKETS

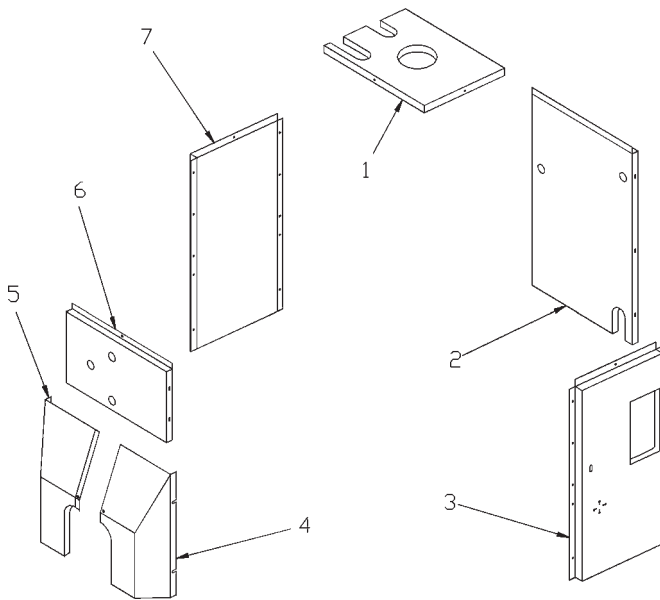

ITEM	PART NO.	DESCRIPTION	QTY
1	21522801	Top Panel - 3 Sec.	1
	21522802	Top Panel - 4 Sec.	
	21522803	Top Panel - 5 Sec.	
	21522806	Top Panel - 6 Sec.	
	21522807	Top Panel - 7 Sec.	
2	21521501	Rear Panel	1
3	21523101	Right Side Panel - 3 Sec.	1
	21523102	Right Side Panel - 4 Sec.	
	21523103	Right Side Panel - 5 Sec.	
	21523104	Right Side Panel - 6 Sec.	
	21523105	Right Side Panel - 7 Sec.	
4	21524401	Lower Cowl - Right	1
5	21524301	Lower Cowl - Left	1
6	21524101	Top Front Panel	1
7	21521803	Left Side Panel - 3 Sec.	1
	21521804	Left Side Panel - 4 Sec.	
	21521805	Left Side Panel - 5 Sec.	
	21521806	Left Side Panel - 6 Sec.	
	21521807	Left Side Panel - 7 Sec.	

REPLACEMENT PARTS - SWING DOOR AND MOUNTING DOOR COMPONENTS

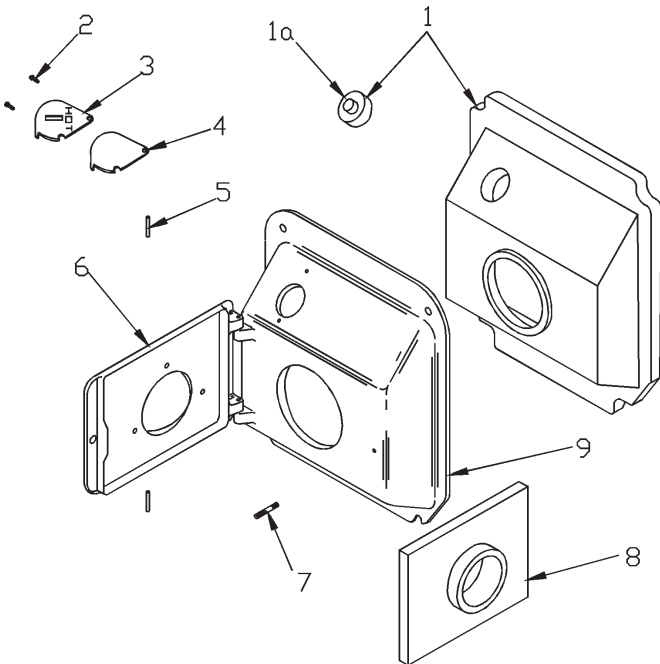

ITEM	PART NO.	DESCRIPTION	QTY
1	2552901	Mounting Door Insulation & Plug	1
1a	2551901	Door Plug Replacement	1
2	HW-005.01	Screw ¼-20x½ Self-Tapping	2
3	10011701	Observation Door	1
4	25511101	Obs. Door Gasket	1
5	HW06801	¼ x 1¾ Drive Lock Pin	2
6	10011501	Swing Door	1
7	HW06701	5/16 x 18 x2-3/8 Stud	1
8	2553301	Insulation - Swing Door (Carlin & Riello Burners)	1
	2553303	Insulation - Swing Door (Beckett AFG Burners)	
9	10011301	Mounting Door	1

REPLACEMENT PARTS - BURNER COMPONENTS

ITEM	PART NO.	DESCRIPTION	QTY
1	BN04002	Burner Oil UT902 Beckett (ESB3100)	1
	BN04003	Burner Oil UT903 Beckett (ESB4125)	
	BN04004	Burner Oil UT904 Beckett (ESB4150)	
	BN04006	Burner Oil UT906 Beckett (ESB5200)	
	BN08901	Burner Oil UT1801 Beckett (ESB6225, ESB7275)	
	30A064202	Burner Oil Riello 40/F5 (ESB3100, ESB4125, ESB4150)	
	BN07007	Burner Oil Riello 40/F10 (ESB5200)	
	BN08401	Burner Oil Carlin EZ-1 (ESB3100)	
	BN08402	Burner Oil Carlin EZ-1 (ESB4125, ESB4150)	
	BN08403	Burner Oil Carlin EZ-2 (ESB5200)	
2	BN08001	Burner Oil Flange Gasket #3616	1
3	CD-001.01	Cad Cell (For Boilers w/Beckett Burners Only)	1
4	RY00701	Control R7184B 1032 (7456U) (For Boilers w/Beckett Burners Only)	1
5	1320004	Nozzle .85 80B (ESB3100 Beckett)	1
	1320006	Nozzle 1.10 80B (ESB4125 Beckett)	
	NZ-002.10	Nozzle 1.25 80B (ESB4150 Beckett)	
	NZ00206	Nozzle 1.75 80B (ESB5200 Beckett)	
	NZ01201	Nozzle 2.00 45B (ESB6225 Beckett)	
	14619346	Nozzle 2.25 45B (ESB7275 Beckett)	
	NZ00802	Nozzle .85 80W (ESB3100 Riello)	
	1320012	Nozzle 1.10 60W (ESB4125 Riello)	
	NZ00804	Nozzle 1.25 60W (ESB4150 Riello)	
	NZ00206	Nozzle 1.75 80B (ESB5200 Riello)	
	1320002	Nozzle .85 70B (ESB3100 Carlin)	
	1320010	Nozzle 1.10 70B (ESB4125 Carlin)	
	NZ00904	Nozzle 1.25 70B (ESB4150 Carlin)	
	NZ00905	Nozzle 1.75 70B (ESB5200 Carlin)	

REPLACEMENT PARTS - BURNER COMPONENTS (BECKETT BURNERS ONLY)

AFG BURNER PARTS

(Used on all boiler models w ith Beckett Burners except ESB6225 and ESB7275)

ITEM	PART NO.	DESCRIPTION
1	RP03801	Blast Tube AFG
2	RP03701	Fuel Pump, 2 Stage, 140 PSI, AFG
	RP03702	Fuel Pump, 1 Stage, 140 PSI, AFG
3	BN07102	Drawer Assembly (Oil Line), AFG
4	BN08001	Burner Gasket
5	RP-015.00	Motor
6	RP-019.01	Transformer

BECKETT CF375 BURNER PARTS

(Used on models ESB6225 and ESB7275)

ITEM	PART NO.	DESCRIPTION
1	RP04501	Fuel Pump, Cleancut (21844U)
2	RP-015.00	Motor, PSC (21805U)
3	RP02001	Transformer (51771U)
4	RP04601	Oil Burner Valve Coil Kit (21755U)

SERVICE CHECKLIST

- Inspect Chimney and Flue Pipe [X]
- Inspect and Clean Appliance [X]
- Inspect Oil Line - Size/Leaks [X]
- Inspect Electrical Connections [X]
- Install New Filter [X]
- Room Make-up Air [X]
- Electrode Setting [X]
- Proper Light-Off (Hot & Cold) [X]
- Controls and Safety Devices [X]
- Nozzle-Size, Angle, Type [*]
- Pump Pressure/Vacuum [*]
- Line Voltage/Motor Amps [*]
- Smoke Test [*]
- Draft-Overfire/In Flue [*]
- CO₂ or O₂ [*]
- Flue Gas Temperature [*]

** Measure with instruments and record results below.*

Date	Nozzle			Pump Pressure PSI	Smoke#	Draft		CO ₂ or O ₂	Flue Temp °F
	Size	Angle	Type			O.F.	INF		