



PRODUCT LITERATURE

Lennox Industries Inc.
Dallas, Texas

INSTALLATION INSTRUCTIONS

GWB8-IE GAS FIRED BOILER

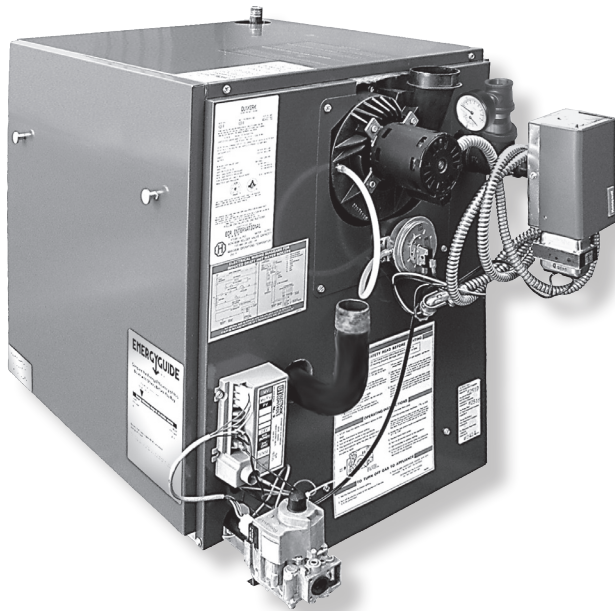

**RETAIN THESE INSTRUCTIONS FOR
FUTURE REFERENCE**

*These instructions must be affixed on
or adjacent to the boiler.*

WARNING



Improper installation, adjustment, alteration, service, or maintenance can cause injury or property damage. Refer to this manual. For assistance or additional information consult a qualified installer, service agency, or the gas supplier.

This boiler cannot be used with all types of chimneys. Read these instructions carefully before installing.



C.S.A. Certified for
Natural gas or Propane



Tested for 50 psi. ASME
Working Pressure



GAS-FIRED HOT WATER BOILERS

These Gas-Fired Water boilers are low pressure, sectional cast iron boilers Design Certified by CSA (Canadian Standards Association) for use with Natural and Propane Gases. They are constructed and hydrostatically tested for a maximum working pressure of 50 psi (pounds per square inch) in accordance with A.S.M.E. (American Society of Mechanical Engineers) Boiler and Pressure Vessel Code Section IV Standards for Cast Iron Heating Boilers.

TABLE OF CONTENTS

Safety Symbols	2
Installation Instructions.....	3
Boiler Ratings And Capacities	3
Before You Start.....	4
Locating The Boiler	5
Fresh Air For Combustion.....	6
Installation System Piping	7
Chimney & Vent Pipe Connection	10
Gas supply Piping	13
Electrical Wiring	14
Sequence of Operation	15
Wiring Diagrams.....	16
Equipment & Optional Accessories	17
Starting Your Boiler.....	19
Checking and Adjusting	20
Initial Operational Boiler Test Check-Out Procedure	22
Maintaining Your Boiler.....	24
Service Hints	25

NOTICE

Read the following instructions completely before installing!

NOTICE

Keep this manual near boiler and retain for future reference.

SAFETY SYMBOLS

The following defined symbols are used throughout this manual to notify the reader of potential hazards of varying risk levels.



DANGER

Indicates a hazardous situation which, if not avoided, will result in death, serious injury.



CAUTION

Indicates a hazardous situation which, if not avoided, may result in injury.



WARNING

Indicates a hazardous situation which, if not avoided, may result in death, serious injury.

NOTICE

Indicates information which should be followed to ensure proper installation and operation.

INSTALLATION INSTRUCTIONS

These instructions must be affixed on or adjacent to the boiler.

This boiler cannot be used with all types of chimneys. Read these instructions carefully before installing.

These Gas-Fired Hot Water Boilers are low pressure, sectional cast iron boilers Design Certified by C.S.A. (Canadian Standards Association) for use with Natural and Propane Gases. They are constructed and hydrostatically tested for a maximum working pressure of 50 psi in accordance with A.S.M.E. Boiler and Pressure Vessel Code Section IV Standards for cast iron heating boilers.

WARNING



Improper installation, adjustment, alteration, service or maintenance can cause injury or property damage. Refer to this manual. For assistance or information consult a qualified installer, service agency or the gas supplier.

BOILER RATINGS AND CAPACITIES

Figure 1 - Boiler Ratings and Capacities

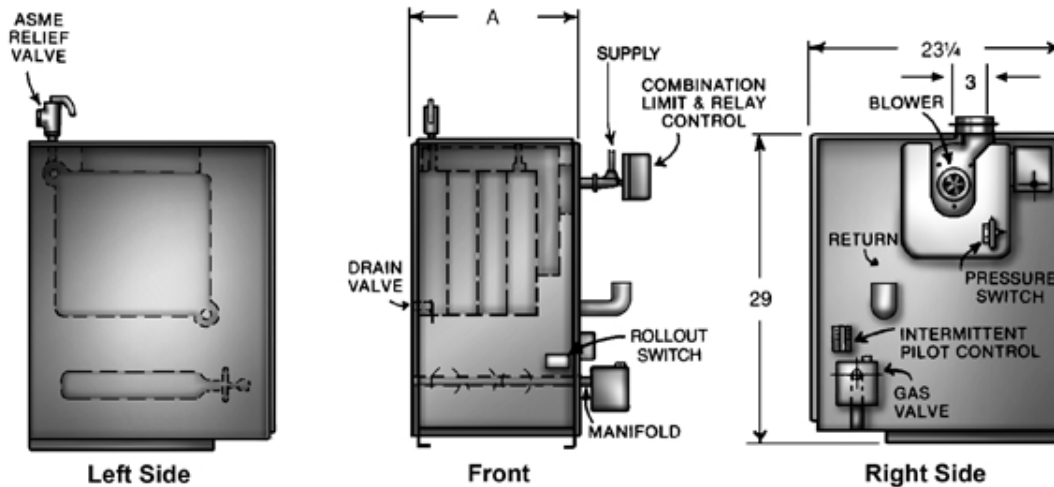

Model	Number of Sections	Input *MBH	Heating Capacity *MBH	Net I=B=R Rating *MBH	Width A	Vent Diameter (Inches)	
						To Chimney (Category I)	Horizontal Vent (Category III)
XEB-2	2	42.5	36	31	11	4	3
XEB-3	3	75.0	63	55	14-1/4	4	3
XEB-4	4	112.5	94	82	17-1/2	4	3
XEB-5	5	150.0	125	109	20-3/4	4	3
XEB-6	6	187.5	155	135	24	4	4
XEB-7	7	225.0	186	162	27-1/4	4	4

* MBH = 1,000 Btuh = British Thermal Unit Per Hour. Boilers are equipped for altitudes up to 2,000 feet only. U.S.A. Only - For altitudes above 2,000 feet, ratings should be reduced at the rate of 4% for each 1,000 feet above sea level. Canada Only - Boilers may be used at high altitude (2,000-4500 feet/640-1350m) by using a certified field conversion kit, resulting in a 10% de-rate. Contact Provincial authority having jurisdiction for installations above 4500 ft (1350m) above sea level.

+ Heating Capacity based on D.O.E. (Department of Energy) test procedure.

New York City MEA Number 484-84-E Vol. IV.

The Ratings marked "Net I=B=R Ratings" indicate the amount of remaining heat input that can be used to heat the radiation or terminal units. The Net I=B=R Ratings shown are based on an allowance of 1.15

Selection of boiler size should be based upon "Net I=B=R Rating" being equal to or greater than the calculated heat loss of the building.

The manufacturer should be consulted before selecting a boiler for installations having unusual piping and pickup requirements.

BOILER RATINGS & CAPACITIES

Boilers must stand on a noncombustible floor. If installed on a combustibile floor, please refer to the Repair Parts manual for the appropriate Combustible Floor Base part number.

Gas-Fired Hot Water Boilers are low pressure, sectional cast iron boilers Design Certified by CSA (Canadian Standards Association) for use with Natural and Propane Gases. They are constructed and hydrostatically tested for a maximum working pressure of 50 psi (pounds per square inch) in accordance with A.S.M.E. (American Society of Mechanical Engineers) Boiler and Pressure Vessel Code, Section IV, Rules for Construction of Heating Boilers.

Boilers For Use At High Altitude

This boiler is factory equipped for use at altitudes of 0-2,000 feet above sea level. For use at altitudes above 2,000 feet above sea level, the input ratings are reduced by a change in main burner orifice size.

U.S.A. Only - For altitudes above 2,000 feet above sea level, input ratings should be reduced at the rate of 4% for each 1,000 feet above sea level. Consult the National Fuel Gas Code (NFPA54/ANSI Z223.1), or the manufacturer for correct orifice sizing information. High altitude orifices are available from the boiler manufacturer.

Canada Only - For altitudes in the range of 2,000-4,500 feet (610 - 1350m) above sea level, boilers may be field equipped for use at high altitude by using a certified field conversion kit. The change in main burner orifice size results in the boiler's input rating being reduced by 10%. The conversion shall be carried out by a manufacturer's authorized representative, in accordance with the requirements of the manufacturer, provincial or territorial authorities having jurisdiction and in accordance with the requirements of CSA-B149 Natural Gas and Propane Installation Code. The certified field conversion kit includes a conversion data plate, which must be attached to the boiler adjacent to the rating plate, indicating that the boiler has been converted for high altitude use. The conversion data plate must be filled in with the correct conversion information.

For altitudes over 4500 feet (1350m), contact Provincial authority having jurisdiction.

BEFORE YOU START

Check to be sure you have the right size boiler before starting installation. See rating and capacity table on previous page. Also be sure the new boiler is for the type of gas you are using. Check the rating plate on the right side of the boiler.

Verify that the boiler is supplied with the correct type of gas, fresh air for combustion, and a suitable electrical supply. Also, the boiler must be connected to a suitable chimney or horizontal venting system and an adequate piping system. Finally, a thermostat, properly located, is needed for control of the heating system. If you have any doubts as to the various requirements, check with local authorities and obtain professional help where needed. Take the time to complete all of the steps for SAFE and PROPER operation of the heating system.

If this boiler is installed in a building under construction, special care must be taken to insure a clean combustion air supply during the construction process. Airborne particulates such as from drywall dust and from fiberglass insulation can clog the burner ports and cause incomplete combustion and sooting. Where required by the authority having jurisdiction, the installation must conform to the Standard for Controls and Safety Devices for Automatically Fired Boilers, ANSI/ASME CSD-1.

Installation must conform to the requirements of the authority having jurisdiction or, in the absence of such requirements, to the National fuel Gas Code, ANSI Z223.1/ NFPA 54, and/or Natural Gas and Propane Installation Code, CAN/CSA B149.1

NOTICE

Installers - Follow local regulations with respect to installation of CO detectors. Follow maintenance recommendations in this instruction manual.

NOTICE

Keep boiler area clean and free from combustible materials, gasoline and other flammable vapors and liquids

LOCATING THE BOILER

If the boiler is part of a planned heating system, locate it where shown on your plan. If boiler is to be part of an existing system, it is usually best to put it where the old one was. If you plan to change location, you will need additional materials as well as an adequate base. The following rules apply:

1. The boiler must be level. Metal shims may be used under base legs for final leveling.
2. Use a raised base if floor can become wet or damp.
3. The vent pipe connection should be as short as possible.
4. Additional clearances for service may exceed clearances for fire protection. Always comply with the minimum fire protection clearances shown on the boiler. An 18 inch clearance should be maintained on any side where passage is required to access for cleaning, servicing, inspection or replacement of any part that may need attention. An 18 inch clearance is recommended on the control side for servicing. **Figure 2** and **Table 2** shows minimum clearances to combustible construction. Consult the National Fuel Gas Code for further information.
5. Equipment shall be installed in a location in which the facilities for ventilation permit satisfactory combustion of gas, proper venting, and maintenance of ambient temperature at safe limits under normal conditions of use. Equipment shall be located so as not to interfere with proper circulation of air. When normal infiltration does not provide the necessary air, outside air shall be introduced (see "Fresh Air for Combustion").
6. Advise owner to keep air passages free of obstructions. Ventilating and combustion air must enter boiler room without restrictions.
7. The floor supporting the boiler must be noncombustible. If it is combustible, please refer to Repair Parts List for the appropriate Combustible Floor Base part number. We use a 2" Cladlite pad as a combustible floor base. These are available from your local supplier. Use 24" x 30" pad for 2-5 section boilers, and a minimum 30" x 30" pad for 6-7 sections boilers. The boiler must be centered on the combustible floor base.
8. The boiler shall be installed such that the automatic gas ignition system components are protected from water (dripping, spraying, rain, etc.) during appliance operation and service (circulator replacement, control replacement, etc..)

Figure 2 - Minimum Clearances To Combustible Construction

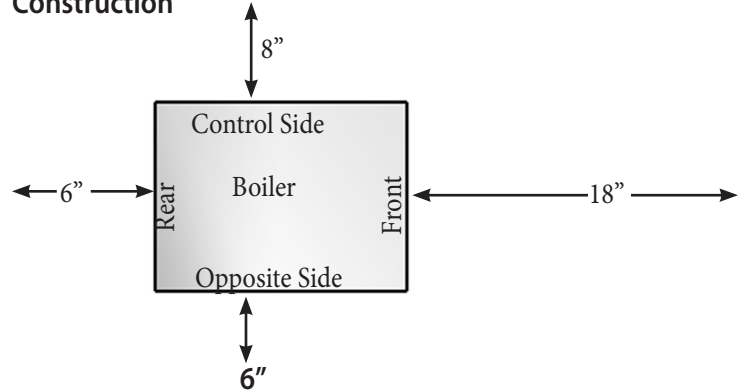

Table 2 - BOILER MINIMUM CLEARANCE TO COMBUSTIBLES

Unit	Minimum Clearances
Top	6" (152mm)
Rear	6" (152mm)
Control Side	8" (203mm)
Opposite Side	6" (152mm)
Front (Alcove)	18" (457mm)
Flue/Vent Connector	6" (152mm)
Near Boiler Piping	1" (24mm)

This unit must be set on a concrete or other noncombustible material base or floor. **IT MUST NOT BE INSTALLED ON CARPETING.**

NOTICE

This unit must be set on a concrete or other noncombustible material base or floor. It must not be installed on carpeting.

FRESH AIR FOR COMBUSTION

Provide combustion air and ventilation air in accordance with the section "Air for Combustion and Ventilation," of the National Fuel Gas Code, ANSI Z223.1/NFPA 54, or Sections 8.2, 8.3 or 8.4 of Natural Gas and Propane Installation Code, CAN/CSA B149.1, or applicable provisions of local building codes.

Provide make-up air where exhaust fans, clothes dryers, and kitchen ventilation equipment interfere with proper operation.

National Fuel Gas Code recognizes several methods of obtaining adequate ventilation and combustion air. Requirements of the authority having jurisdiction may override these methods.

- Engineered Installations. Must be approved by authority having jurisdictions.
- Mechanical Air Supply. Provide minimum of 0.35 cfm per Mbh for all appliances located within space. Additional requirements where exhaust fans installed. Interlock each appliance to mechanical air supply system to prevent main burner operation when mechanical air supply system not operating.
- All Indoor Air. Calculate minimum volume for all appliances in space. Use a different method if minimum volume not available.
 - Standard Method. Cannot be used if known air infiltration rate is less than 0.40 air changes per hour. See Table 3 for space with boiler only. Use equation for multiple appliances.

$$\text{Volume} \geq 50 \text{ ft}^3 \times \text{Total Input [Mbh]}$$
 - Known Air Infiltration Rate. See Table 3 for space with boiler only. Use equation for multiple appliances. Do not use an air infiltration rate (ACH) greater than 0.60.

$$\text{Volume} \geq 15 \text{ ft}^3/\text{ACH} \times \text{Total Input [Mbh]}$$
 - Refer to National Fuel Gas Code for opening requirements between connection indoor spaces.

- All Outdoor Air. Provide permanent opening(s) communicating directly or by ducts with outdoors.
 - Two Permanent Opening Method. Provide opening commencing within 12 inches of top and second opening commencing within 12 inches of bottom enclosure.
 - Direct communication with outdoors or communicating through vertical ducts. Provide minimum free area of 1 in² per 4 Mbh of total input rating of all appliances in enclosure.
 - Communicating through horizontal ducts. Provide minimum free area of 1 in² per 2 Mbh of total input rating of all appliances in enclosure.
 - One Permanent Opening Method. Provide opening commencing within 12 inches of top of enclosure. Provide minimum clearance of 1 inch on sides and back and 6 inches on front of boiler (does not supersede clearance to combustible materials).
 - Combination Indoor and Outdoor Air. Refer to National Fuel Gas Code for additional requirements for louvers, grilles, screens and air ducts.
- Combination Indoor and Outdoor Air. Refer to National Fuel Gas Code for application information.

National Gas and Propane Installation Code Requires providing air supply in accordance with:

- Section 8.2 and 8.3 when combination of appliances has a total input of up to and including 400 Mbh (120 kW).
 - Does not have draft control device.
- Section 8.4 when combination of appliances has total input exceeding 400 Mbh (120 kW).
- Refer to Natural Gas and Propane Installation Code for specific air supply requirements for enclosure or structure where boiler is installed, including air supply openings and ducts.

Table 3

Input Mbh	Standard Method	Known Air Infiltration Rate Method (Air Changes Per Hour)					
		0.1	0.2	0.3	0.4	0.5	0.6
42.5	2125	6375	3188	2125	1594	1275	1063
75	3750	11250	5625	3750	2813	2250	1875
112.5	5625	16875	8438	5625	4219	3375	2813
150	7500	22500	11250	7500	5625	4500	3750
187.5	9375	28125	14063	9375	7031	5625	4688
225	11250	33750	16875	11250	8438	6750	5625

WARNING

To avoid burns, scalding, or water damage due to discharge of steam and/or hot water during operation, a discharge line shall be installed to relief valve outlet connection.

The discharge line shall:

- connect to relief valve outlet and piped down to safe point of disposal.
- be of pipe size equal to or greater than that of the relief valve outlet over the entire length of discharge line;
- have no intervening shutoff valve between safety relief valve and discharge to atmosphere (do not plug or place any obstruction in discharge line).
- terminate freely to atmosphere where any discharge will be clearly visible and at no risk of freezing;
- allow complete drainage of the valve and the discharge line;
- be independently supported and securely anchored to avoid applied stress on the relief valve;
- be as short and straight as possible;
- terminate with plain end (not threaded);
- be constructed of material suitable for exposure to temperatures of 375° F or greater;

Refer to local codes and appropriate ANSI/ASME Boiler and Pressure Vessel Code, Section IV, or Boiler, Pressure Vessel and Pressure Piping Code, CSA B51 for additional installation requirements.

1. Place boiler in the selected location (as near chimney as possible). Your boiler is shipped assembled. You need only to install the circulator, ball valves, the relief valve with a drain line to carry any water to a drain, and the drain valve.
2. Install relief valve on 3/4" pipe nipple in tapped boiler opening. Pipe the discharge line following guidelines in the preceding **Warning**. Refer to example shown in **Figure 4**. The discharge line pipe size shall be equal or greater than that of the relief valve outlet over the entire length of discharge line with no intervening shutoff valve between the safety relief valve and discharge to atmosphere. The discharge line shall terminate with a plain end to atmosphere where any discharge will be clearly visible and is at no risk of freezing. The discharge line shall be independently supported to avoid applied stress on the relief valve. The installation shall allow complete drainage of the relief valve and the discharge line. The discharge line shall be as short and straight as possible and constructed of a material suitable for exposure to temperatures of 375° F or greater.
3. Refer to local codes and appropriate ASME Boiler and Pressure Vessel Code for additional installation requirements.
4. Install Drain Valve on lower left side of boiler as marked.
5. Install Temperature and Pressure Gauge into 1/4" bushing threaded in tee furnished with supply piping See **Figures 5 and 6**.
6. Connect Supply and Return Lines to boiler, as shown in **Figures 5 and 6**. The connections may require certain additional fittings and parts.

Figure 4 - Relief Valve Discharge Piping

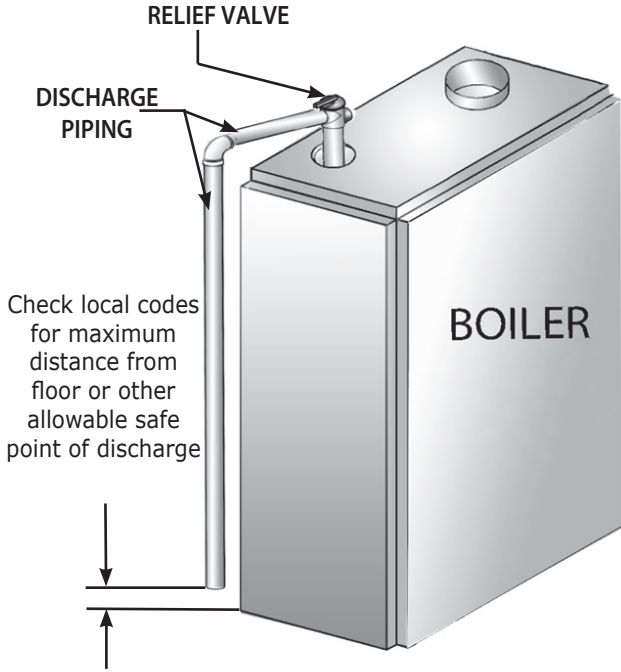

Figure 5 - Forced Hot Water Typical Piping

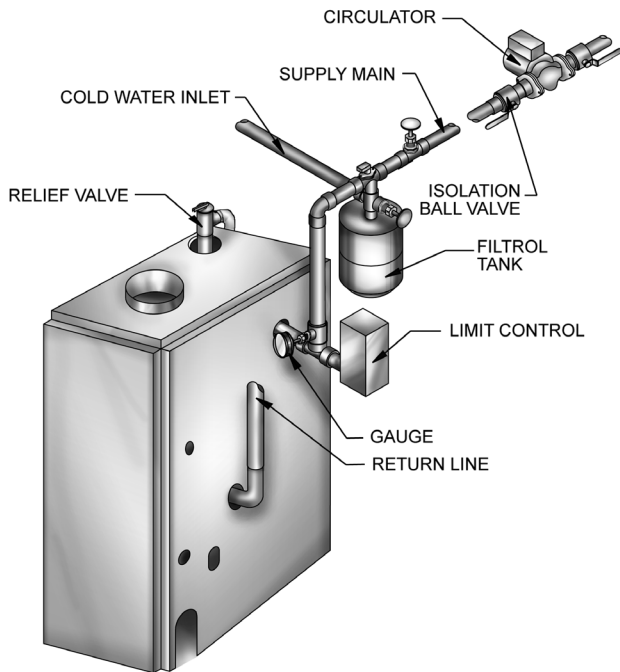
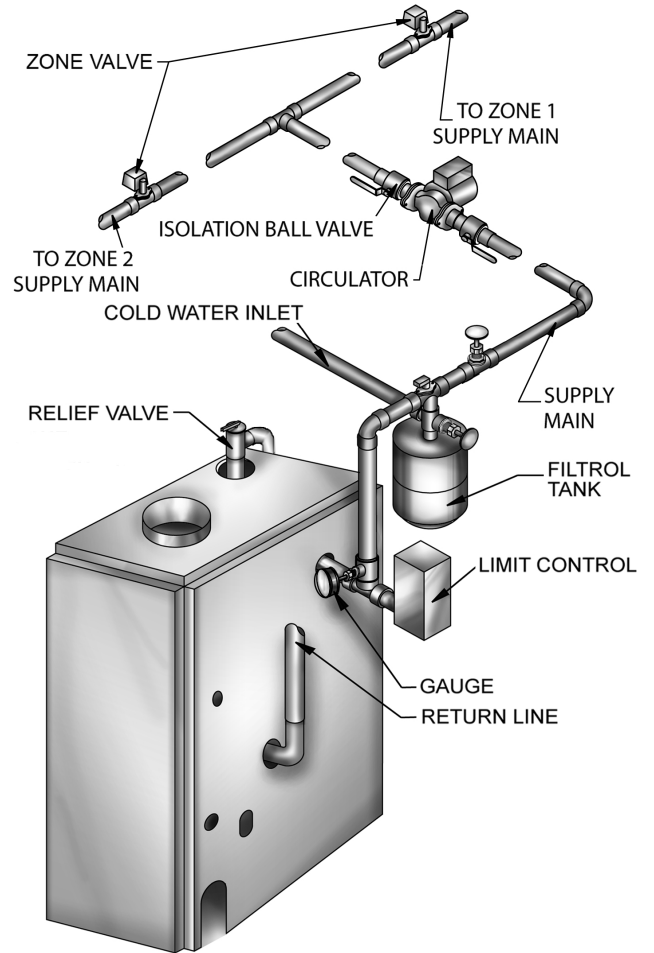

Figure 6 - Forced Hot Water Typical Piping With Zone Control Valve



If you are installing an entire new heating system, first install all of your radiation units (panels, radiators or cabinets) and the Supply and Return Mains - then make the connections at the boiler.

In connecting the cold water supply to the water valve, make sure that a clean water supply is available. When the water supply is from a well or pump, a sand strainer should be installed at the pump.

A hot water boiler installed above radiation level or as required by the Authority having jurisdiction, must be provided with a low water cutoff device either as a part of the boiler or at the time of boiler installation. A periodic inspection is necessary, as is flushing of float type devices, per manufacturers specific instructions.

When the boiler is used in connection with refrigeration systems it shall be installed so that the chilled medium is piped in parallel with the heating boiler with appropriate valves to prevent the chilled medium from entering the heating boiler (**Figure 7**).

If the boiler is connected to heating coils located in air handling units where they may be exposed to refrigerated air circulation, the piping system shall be equipped with flow control valves or other automatic means to prevent gravity circulation of the boiler water during the cooling cycle.

Low Design Water Temperature Systems (Below 140° F) And Large Water Content Systems:

WARNING



Significant condensation may form in this boiler and/or the venting system if the boiler is operated with return temperatures of less than 120° F.

This condensation is corrosive and can eventually cause severe damage to the boiler and venting system. The minimum design return water temperature to prevent this condensation in the boiler and venting is 120°F. The minimum high limit setting is 140°F.

If the boiler is to be used in a heating system where design water temperatures below 140°F are desired (e.g. radiant floor heating), a 3-way or 4-way mixing valve or suitable alternative is required to prevent low temperature return water from entering the boiler. When using a mixing valve, follow the manufacturer's installation instructions.

If the boiler is to be connected to a system having a large water content (such as a former gravity system), it is suggested to use bypass piping shown in **Figure 8**.

Figure 7 - Piping Arrangements For Boiler When Used In Connection With Refrigeration System

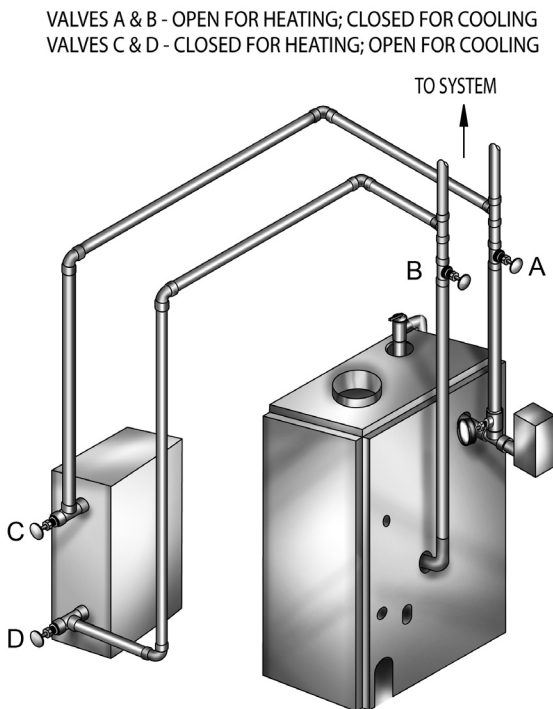
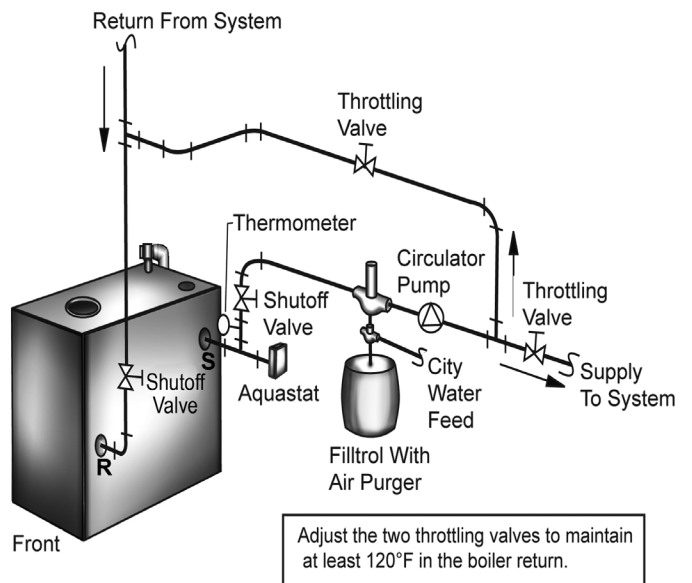

Figure 8 - Bypass Piping



Check Your Chimney

This is a very important part of your heating system. It must be clean, the right size, properly constructed and in GOOD CONDITION. No boiler can function properly with a bad chimney.

1. Installation must conform to the requirements of the authority having jurisdiction or, in the absence of such requirements, to the National Fuel Gas Code, ANSI Z223.1/NFPA 54, and/or Natural Gas and Propane Installation Code, CAN/CSA B149.1.
2. The boiler's induced draft blower has a 3" outlet. A 3" X 4" increaser fitting is included in the parts bag. Locate the increaser fitting on the outlet of the induced draft blower, and secure gas-tight with a bead of the furnished silicone sealant. The increaser fitting is required on this boiler for Category I venting, and 4" is the minimum permissible vent diameter. This does not imply that the vent connector is intended to be 4" diameter pipe. The vent connector shall be sized according to the appropriate venting tables in the National Fuel Gas Code or the Canadian Installation Codes, and may be required to be larger than 4" diameter.

NOTICE

The boiler installation for chimney venting is not complete unless the 3" x 4" increaser fitting is located and secured.

3. These are high efficiency boilers with a low stack or exhaust temperature.
4. If venting into a masonry chimney without a liner, line the chimney from top to bottom with either:
 - A. Listed Type B vent pipe
 - B. Listed flexible vent liner
 - C. Poured ceramic liner.
5. Outside chimneys should not be used unless they are (choose one of the following):
 - A. Enclosed in a chase
 - B. Lined with Type B vent pipe
 - C. Use a listed flexible vent liner
 - D. Use a certified chimney lining system
6. The vent connector from the boiler to the chimney should run as directly as possible with as few elbows as possible.
7. Where possible, it is recommended to common vent the water heater and boiler. Consult the appropriate Vent Sizing Tables in either the National Fuel Gas Code, or the Canadian Installation Codes for specific requirements of multiple appliance venting.

8. If the boiler is the only appliance connected to the vent, Type B vent pipe is recommended for the vent connector.
9. Slope pipe up from boiler to chimney not less than 1/4" per foot (21mm/m).
10. End of vent pipe must be flush with the inside face of the chimney flue. Use a sealed-in thimble for the chimney connection.
11. The sections of vent pipe should be fastened with sheet metal screws to make the piping rigid. Use stovepipe wires to support the pipe from above.
12. Do not connect to fireplace flue.
13. Do not install a damper on this boiler.

Minimum Vent Pipe Clearance

If the vent pipe must go through a crawl space, Type B vent pipe should be used. Where vent pipe passes through a combustible wall or partition, use a ventilated metal thimble. The thimble should be 4 inches larger in diameter than the vent pipe.

If boiler is installed with single wall vent, it must have a 6" clearance between its surface and any combustible material. A new Type B gas vent or flexible liner must be installed in accordance with the instructions furnished with the vent. Maintain clearances as specified for the vent pipe.

Check the vent pipe to see if it is fire-stopped where it goes through the floor or ceiling. It should have an approved vent cap with clearances from the roof as shown in **Figure 9**. If clearances are less than shown in **Figure 9**, have the vent checked by local authorities.

Vent connectors serving appliances vented by natural draft shall not be connected into any portion of mechanical draft systems operating under positive pressure.

Removing Existing Boiler From Common Venting System

When an existing boiler is removed from a common venting system, the common venting system is likely to be too large for proper venting of the appliances remaining connected to it.

At the time of removal of an existing boiler, the following steps shall be followed with each appliance remaining connected to the common venting system placed in operation, while the other appliance remaining connected to the common venting system are not in operation.

1. Seal any unused openings in the common venting system.
2. Visually inspect the venting system for proper size and horizontal pitch and determine there is no blockage or restriction, leakage, corrosion and other deficiencies which could cause an unsafe condition.

Figure 9 - Type B Gas Vent

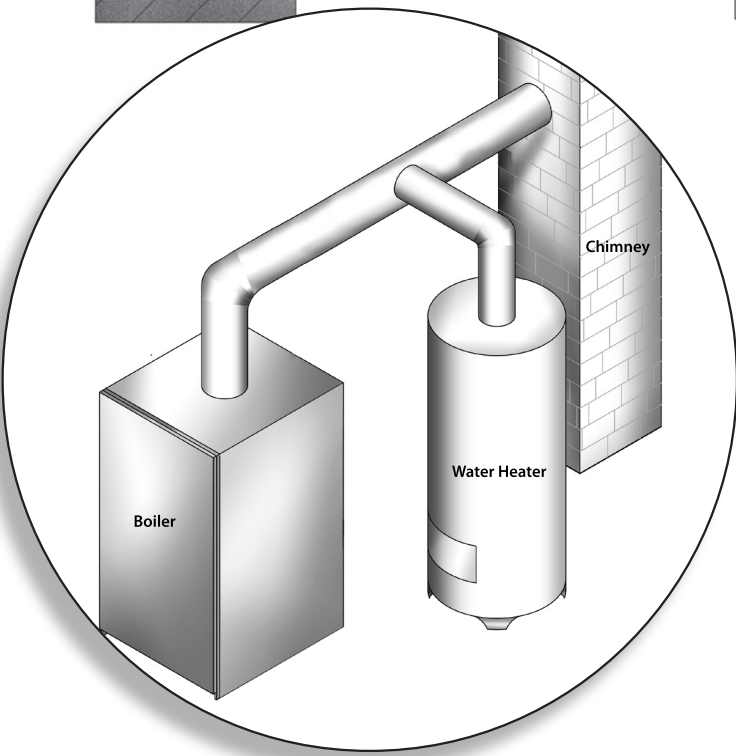
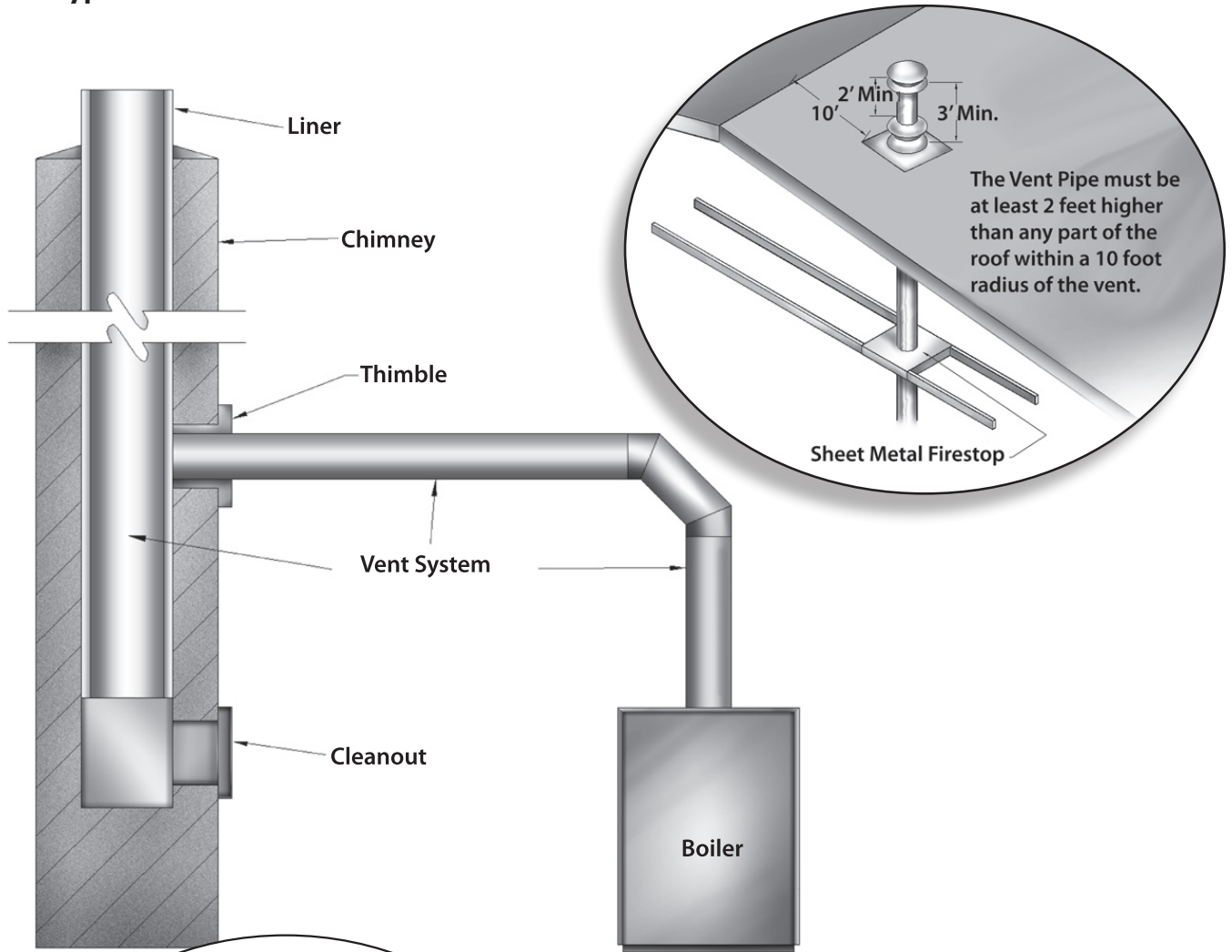

CHECK YOUR CHIMNEY

For boilers for connection to gas vents or chimneys, vent installations shall be in accordance with "Venting of Equipment", of the National Fuel Gas Code, ANSI Z223.1/ NFPA 54, or "Venting systems and Air Supply for Appliances", of the Natural Gas and Propane Installation Code, CAN/CSA B149.1, or applicable provisions of the local building codes.

CHIMNEY & VENT PIPE CONNECTION

3. Insofar as is practical, close all building doors and windows and all doors between the space in which the appliances remaining connected to the common venting system are located and other spaces of the building. Turn on clothes dryers and any appliance not connected to the common venting system. Turn on any exhaust fans, such as range hoods and bathroom exhausts, so they will operate at maximum speed. Do not operate a summer exhaust fan. Close fireplace dampers.
4. Place in operation the appliance being inspected. Follow the lighting instructions. Adjust thermostat so appliance will operate continuously.
5. Test for spillage at the draft hood relief opening after 5 minutes of main burner operation. Use the flame of a match or candle, or smoke from a cigarette, cigar, or pipe.
6. After it has been determined that each appliance remaining connected to the common venting system properly vents when tested as outlined above, return doors, windows, exhaust fans, fireplace dampers and any other gas-burning appliance to their previous conditions of use.
7. Any improper operation of the common venting system should be corrected so the installation conforms with the National Fuel Gas Code, ANSI Z223.1/NFPA 54, and/or the Natural Gas and Propane Installation Code, CAN/CSA B149.1. When re-sizing any portion of the common venting system, the common venting system should be re-sized to approach the minimum size as determined using the appropriate tables in Chapter 13 of the National Fuel Gas Code, ANSI Z223.1/NFPA 54, and the Natural Gas and Propane Installation Code, CAN/CSA B149.1.

NOTICE

It is recommended that existing gas vents be checked to be sure they meet local codes.

CAUTION

WHAT TO DO IF YOU SMELL GAS

Do not try to light any appliance.

Do not touch any electrical switch; do not use any phone in your building.

Immediately call your gas supplier from a neighbor's phone. Follow gas supplier's instructions.

If you cannot reach your gas supplier, call the fire department.

2. All pipe compound must be resistant to liquefied petroleum gas.
3. Install ground joint union in gas supply line between shut-off valve and boiler controls.
4. Install a sediment trap upstream of gas controls.
5. Use two pipe wrenches when making the connection to the gas valve to keep it from turning.
6. Install manual shut-off valve in vertical pipe about 5 feet (1.5m) above floor.
7. Tighten all joints securely.
8. Propane gas connections should only be made by a licensed propane installer.
9. Two-stage regulation should be used by the propane installer.
10. Propane gas piping should be checked out by the propane installer.

Connecting The Gas Piping

Refer to **Figure 12** for the general layout at the boiler. It shows the basic fittings you will need. The gas line enters the boiler from the right side. Flexible gas connectors must never breach any boiler openings.

Figure 12 - Gas Piping At Boiler

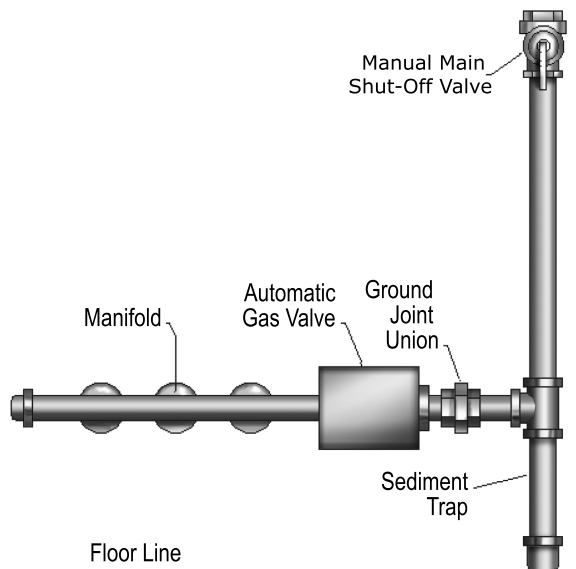

Check Gas Supply

The gas pipe to your boiler must be the correct size for the length of the run and for the total BTU per hour input of all gas utilization equipment connected to it. See Gas Table 8 for the proper size. Be sure your gas line complies with local codes and gas company requirements.

DANGER



Fire Hazard. Do not use matches, candles, open flames, or other methods providing ignition source. Failure to comply will result in death or serious injury.

Checking The Gas Piping

Pressure test boiler and gas connection before placing boiler in operation.

- Pressure test over 1/2 psig (3.5 kPa). Disconnect boiler and its individual gas shutoff valve from gas supply system.
- Pressure test at 1/2 psig (3.5 kPa) or less. Isolate boiler from gas supply system by closing manual gas shutoff valve. See figure 7-6.
- Locate leakage using gas detector, noncorrosive detection fluid, or other leak detection method acceptable to authority having jurisdiction. Do not use matches, candles, open flames, or other methods providing ignition source.
- Correct leaks immediately and retest.

Table 7		
PRESSURE	GAS	
	NATURAL	PROPANE
MIN. SUPPLY	5" w.c.	11" w.c.
MAX. SUPPLY	13.5" w.c.	13.5" w.c.
MANIFOLD	3.5" w.c.	10" w.c.

The following rules apply:

1. Use piping materials and joining methods acceptable to authority having jurisdiction. In absence of such requirements:
USA - National Fuel gas Code, ANSI Z223.1/NFPA 54
Canada - Natural Gas and Propane Installation Code, CAN/CSA B149.1

GAS SUPPLY PIPING

Table 8a - NATURAL GAS

Length of Pipe - Ft.	Pipe Capacity - BTU Per Hour Input Includes Fittings			
	1/2"	3/4"	1"	1 1/4"
20	92,000	190,000	350,000	625,000
40	63,000	130,000	245,000	445,000
60	50,000	105,000	195,000	365,000

Table 8b - PROPANE GAS

Length of Pipe - Ft.	Pipe Capacity - BTU Per Hour Input Includes Fittings			
	Copper Tubing*		Iron Pipe	
	5/8"	3/4"	1/2"	3/4"
20	131,000	216,000	189,000	393,000
40	90,000	145,000	129,000	267,000
60	72,000	121,000	103,000	217,000

***Outside diameter:**

The length of pipe or tubing should be measured from the gas meter or propane second stage regulator.

ELECTRICAL WIRING

All electrical work must conform to the requirements of the authority having jurisdiction or, in the absence of such requirements, with the National Electrical code, ANSI/NFPA 70, and/or the Canadian Electrical Code Part I, CSA C22.1, Electrical Code

WARNING



Electrical shock hazard. Turn OFF electrical power supply at service panel before making electrical connections. Failure to do so could result in death or serious injury.

Electric Power Supply

Run a separate 115 volt circuit from a separate over current protective device in the electrical service entrance panel. This should be a 15 ampere circuit. Locate a shut-off switch at the boiler. It must be turned off during any maintenance. Connect 115 volt power supply to aquastat terminals L1 (HOT) and L2.

The boiler, when installed, must be electrically bonded to ground in accordance with the requirements of the authority having jurisdiction or, in the absence of such requirements, with the National Electrical code, ANSI/NFPA 70, and/or the Canadian Electrical Code Part I, CSA C22.1, Electrical Code. Run a 14 gauge or heavier copper wire from the boiler to a grounded connection in the service panel or a properly driven and electrically grounded ground rod.

CAUTION



Label all wires prior to disconnection when servicing controls. Wiring errors can cause improper and dangerous operation. Verify proper operation after servicing.

Install Your Thermostat

The thermostat location has an important effect on the operation of your boiler system. BE SURE TO FOLLOW THE INSTRUCTIONS INCLUDED WITH YOUR THERMOSTAT. Locate the thermostat about five feet (5') above the floor on an inside wall. It may be mounted directly on the wall or on a vertically mounted outlet box. It should be sensing average room temperature.

THERMOSTAT LOCATIONS TO AVOID

DEAD SPOTS	HOT SPOTS	COLD SPOTS
Behind doors	Concealed pipes	Concealed pipes or ducts
	Fireplace	
	TV sets	Stairwells - drafts
Corners & alcoves	Radios	Doors - drafts
	Lamps	Unheated room on other side of wall
	Direct sunlight	
	Kitchens	

Set heat anticipator at .2 amps. The 24 volt thermostat connects to aquastat terminals T and T.

Sequence of Operation - Refer to Figure 13

1. Thermostat calls for heat, powering the 1K relay coil and closing contacts 1K1 and 1K2.
2. Circulator pump is powered through terminals C1 and C2.
3. Induced draft blower and transformer primary are powered through terminals B1 and B2.
4. When blower gets up to speed and blower suction pressure reaches pressure switch set point, pressure switch contacts close sending 24 volts to intermittent pilot control from transformer secondary.
5. Pilot gas valve opens and spark initiates to light pilot burner.
6. When pilot flame is proven, spark drops out.
7. Main gas valve opens and pilot burner ignites main burners.
8. If boiler water temperature reaches high limit set point, high limit contacts B-R open, cutting power to blower and intermittent pilot control. Burners extinguish and blower stops. Circulator pump continues to run as long as the thermostat continues to call for heat. When boiler water temperature drops past the high limit set point and through the differential, high limit contacts B-R close, repeating steps 3-7.
9. If venting system becomes blocked, blower suction pressure will drop below the pressure switch set point, opening the pressure switch contacts and cutting power to the intermittent pilot control. Burners will extinguish, but blower will remain powered as long as the thermostat continues to call for heat. If venting system clears, steps 4-7 will repeat.
10. Thermostat is satisfied, ending call for heat. Relay coil 1K is de-energized, opening 1K1 and 1K2 contacts. Burners extinguish. Blower and circulator pump stop.

Figure 13 - Intermittent Ignition

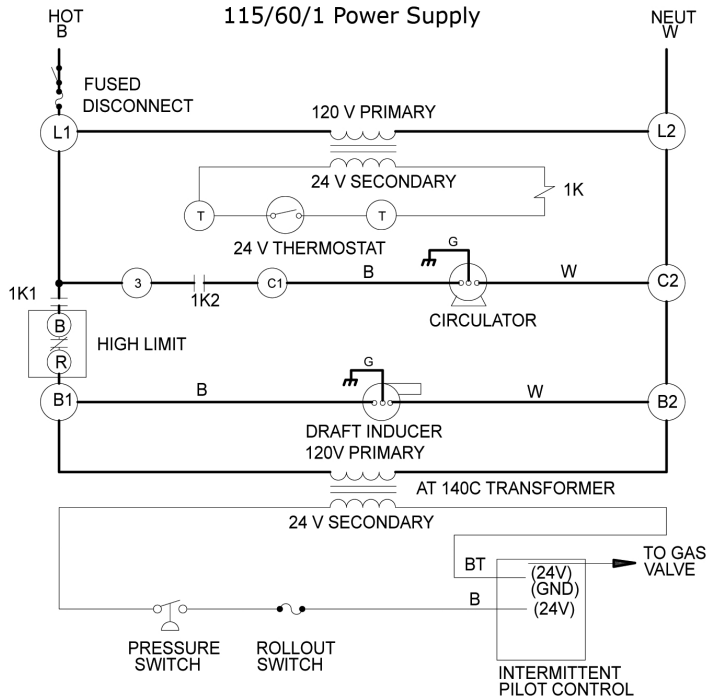
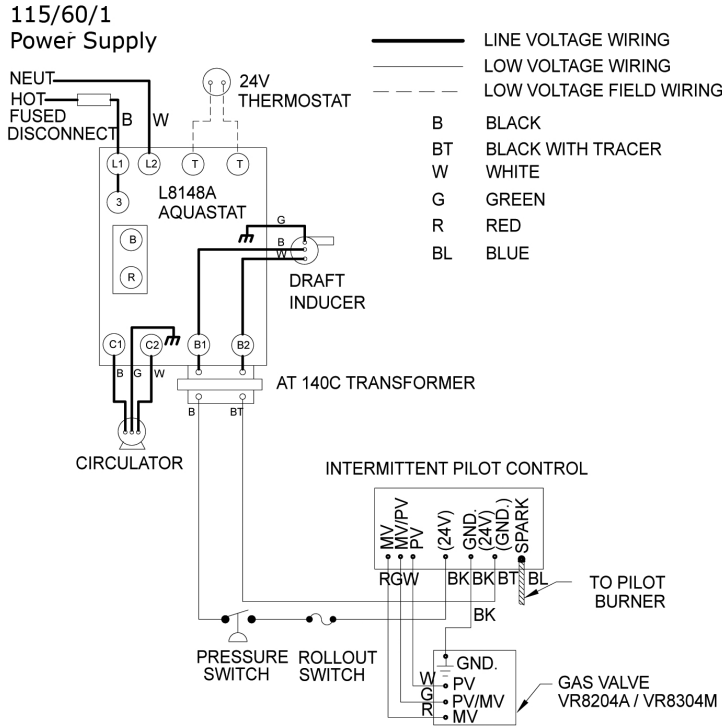

NOTICE

If any of the original wire as supplied with this appliance must be replaced, it must be replaced with type 105° C thermoplastic wire or its equivalent.

NOTICE

The circulator harness is factory wired to the aquastat. This harness needs to be connected to the circulator in the field.

Relief Valve

You must have a relief valve on your boiler. Water expands as it is heated. If there is no place for the water to expand into, water pressure will build up inside the boiler and system. Should this happen, the Relief Valve will automatically open at a pre-determined pressure. This will relieve the strain on the boiler and system. Run a pipe from the relief valve outlet (pipe must be same size as outlet and the open end must not be threaded) to an open drain, tub or sink, or other suitable drainage point not subject to freezing. Failure to do so may cause water damage or injury should relief valve release.

Expansion Tank

In a properly assembled system, the expanding water flows into an Expansion Tank. This tank should be of the correct size.

The tank is partially filled with air. As the water expands it compresses the air in the tank to form an air pressure cushion. This "spring-like" cushion serves to maintain correct operating water pressure regardless of water temperature. This assures a "full measure" of water, even in the highest radiation unit of the system. It also prevents blowing off of the relief valve.

The air in the tank in the beginning (with system filled with cold water) is sufficient for proper operation. The tank also serves as a trap for excess air in the system. The air would cause gurgling in the pipes and inefficient circulation in the radiators if left in the system.

It is possible for a tank to become "waterlogged" (filled with water). It can also become overfilled with air. This can happen after filling the system with new water. Fittings provided on the tank and in the line to the tank are for bleeding off excess water or air.

When installing this tank, it is important:

- 1) That the tank be higher than the boiler top.
- 2) That the pipe to the tank continuously rises up to the tank (so that air can "bubble" up to it).

Diaphragm Type Expansion Tank

The Diaphragm Type Expansion Tank (EX-TROL) takes the place of the conventional expansion tank. Carefully read the instructions packed with your EX-TROL Tank Assembly. The EX-TROL Tank comes to you with a 10-12 pounds per square inch air charge. This is the same as the pressure produced in the system by the automatic fill valve. When the system is first filled, the EX-TROL Tank will contain little or no water.

As the water is heated its pressure increases. It expands into the EX-TROL Tank, compressing the air in the tank. This compressed air cushion permits the water in the system to expand as the temperature changes.

Air Eliminating Fitting (Air Purger)

An Air Purger is used to remove excess air from the system. It is installed in the supply line. It will help to eliminate air from the water before it reaches the radiators and bleed off this air.

Main Air Vent For Down Flow Systems Or Diaphragm Type Expansion Tank

Before a system is filled with water, there is air in the pipes and radiation units. Some of it will be trapped as the system is filled. It is possible to eliminate most of this air through the air vents on the radiation units. A Main Air Vent will speed and simplify this. It should be installed on the highest point in the main when all radiation is below top of boiler.

Automatic Fill Valve

For safe, efficient operation, a hot water system must be filled with water. Adding new water, when needed can be done manually (by use of a hand valve in the water supply line). This requires regular attention to the system's needs. An Automatic Fill Valve accomplishes this without attention. It is installed in the Supply Line on hot water boilers only. The Valve operates through water pressure differentials. It does not require an electrical connection.

Drain Valve

This manual valve provides a means of draining all water from the boiler and system. It is often installed in the ¾" Tapping at the bottom of the left boiler section. Or it can be installed in a tee where the return line enters the boiler.

Water Temperature Control

The water temperature limit control in the relay is adjustable and may be set as necessary. It may be set as low as 140° F, or as high as 240° F. This depends on the type and amount of radiation involved and weather conditions.

Circulating Pump

Every Forced Hot-Water System requires a Circulating Pump. A separate pump or zone valve is required for each Zone, if you have a two or more Zone System. This pump must have the capacity to provide the circulation required by your system.

The pump does not come pre-installed on the boiler. It must be connected to the circulator harness in the field according to the pump manufacturer's instructions and the wiring diagrams in this manual.

Blower (Draft Inducer)

The blower provides a means for pulling air through the boiler and exhausting the flue gasses into the vent system. The blower shuts off when the burners are not firing. This keeps heat in the house rather than having it go up the chimney.

Pressure Switch

The air pressure switch works on a negative pressure. When the blower comes on the air pressure switch operates the intermittent pilot and gas valve. The air pressure switch is factory set and will only work when the blower operates properly. It will not allow the boiler to come on if the blower does not generate enough pressure or if the venting system is blocked.

Factory Pressure Switch Set point:

-0.4" wc. for 2-5 section boilers.

-0.5" w.c. for 6-7 section boilers.

Rollout Switch

(Flame Rollout Safety Shutoff)

The rollout switch is a temperature-sensitive fuse link device. It is located on the boiler base just outside the fire box. In the event of heat exchanger flue-way blockage causing flame to roll out of the fire box, the fuse will blow, shutting down the flow of gas to the main burners. The fuse does not change in appearance when blown.

If the rollout switch blows, it must be replaced with an exact replacement. Check heat exchanger flue-ways for blockage when restoring system to operating condition. Do not operate system without a rollout switch.

How A Hot Water System Operates

Your entire heating system (boiler, piping and radiation units) is filled with water. As the water in the boiler is heated, it is pumped from the top of the boiler through the supply main to the radiation units. The cooler water in them flows back through the return main to the boiler. This provides positive and rapid response to the thermostat.

 **WARNING**
Never run water into a hot empty boiler.

Filling System With Water

Close the Air Vents on all radiation units. Open the Valves to these units. Make sure the boiler and Expansion Tank Drain Cocks are closed. The Air Bleed Screw on the tank Drain Fitting should be closed. Open the valve in the line from the boiler to the expansion tank. Open the water inlet to your boiler and leave it open. Start with the lowest radiation unit. Open the air vent on this unit. When all the air has escaped and water starts to flow from the vent, close it. Go to the next radiation unit, and repeat this process. Repeat until you have covered every radiation unit in the system (ending up at the highest unit in the system). If your units have automatic vents, this manual venting is unnecessary but it will speed up the proper filling of your system.

If your system is a closed expansion tank system, you may have an Automatic Fill Valve. You may leave it open to refill the system automatically as needed. Check the temperature-pressure gauge. Note the position of the hand indicating pressure. This should be between 10 and 15 psig. Any lowering of this movable hand below 10 psig. will indicate loss of water due to leakage. The automatic fill valve should compensate for this. Instructions are packaged with the valve.

WARNING

BEFORE OPERATING smell all around the appliance area for gas. Be sure to smell next to the floor because some gas is heavier than air and will settle on the floor.

WHAT TO DO IF YOU SMELL GAS

- Do not try to light any appliance.
- Do not touch any electrical switch; do not use any phone in your building.
- Immediately call your gas supplier from a neighbor's phone. Follow gas supplier's instructions.
- If you cannot reach your gas supplier, call the fire department.

Do not use this appliance if any part has been under water. Immediately call a qualified service technician to inspect the appliance and to replace any part of control system and any gas control which has been under water.



WARNING

If you do not follow these instructions exactly, fire or explosion may result with personal injury, or loss of life.

This appliance is equipped with an ignition device which automatically lights the burner. Do not attempt to light the burner by hand.



Use only your hand to push down or turn the knob. Never use tools. If the knob will not operate by hand, don't try to repair it, call a qualified service technician. Force or attempted repair may result in fire or explosion.

STARTING YOUR BOILER

Operating Instructions.

1. **STOP! Read Safety Information on previous page.**
2. Set the thermostat to lowest setting.
3. Turn off all electric power to the appliance.
4. This appliance is equipped with an ignition device which automatically lights the burner. Do not attempt to light the burner by hand.
5. Remove burner access panel.
6. Depress gas control knob slightly and turn clockwise  to "OFF" position.

Figure 14 - Gas Control Knob



NOTICE

Knob cannot be turned to "OFF" unless knob is depressed slightly. Do not force.

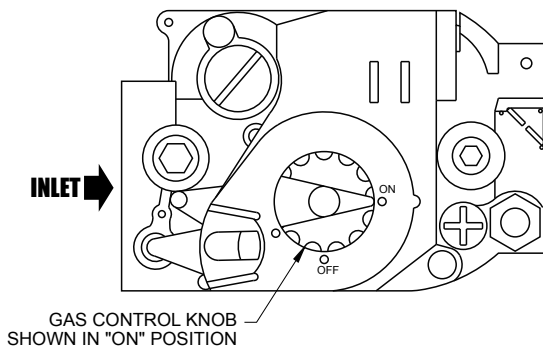
WARNING



Wait five (5) minutes to clear out any gas. If you then smell gas **STOP! Follow WHAT TO DO IF YOU SMELL GAS** on previous page. If you don't smell gas, go to next step.

7. Turn gas control knob counterclockwise  to "ON."
8. Turn on all electric power to the appliance.
9. Set thermostat to desired setting.
10. After visually inspecting the flame, replace lower front panel.

WARNING



If the appliance will not operate after several tries, turn the gas control knob to "OFF" and call your service technician or gas supplier.

To Turn Off Appliance:

1. Set the thermostat to lowest setting.
2. Turn off all electric power to the appliance if servicing is to be performed.
3. Depress gas control knob slightly and turn clockwise  to "OFF" position. Do not force.

CHECKING AND ADJUSTING

Gas Valve Safety Shutdown Test

Ignition system safety shutoff device must be tested after placing boiler in operation.

With main burners firing, disconnect the ignition cable from the intermittent pilot control box. The gas valve should shut off the main burners. **TURN OFF ELECTRIC POWER** to boiler before reconnecting ignition cable, to prevent electric shock.

Adjust Pilot Burner

1. Remove screw cover over pilot adjusting screw.
2. Insert small screwdriver and adjust flame as needed (**Figure #16**. Turn screw counterclockwise  to increase flame, clockwise to decrease (**Figure #17**).
3. Replace screw cover over pilot adjusting screw.

Main Burner(S)

The main burners do not require primary air adjustment and are not equipped with primary air shutters.

Main burner flames should form sharp blue inner cones in a softer blue outer mantel, with no yellow. Puffs of air from blowing on the flame or stamping on the floor will cause the flames to turn orange momentarily. *This is not unusual.* Remain still when observing the main burner flames. Refer to **Figure #17**.

If flame appearance is not correct, check main burner orifices and burner throat and flame ports for dust and lint obstruction. It may be necessary to remove rollout shield to observe main burner flames. Replace rollout shield after observation.

Adjust Limit Controls

Instructions for each control are included with the controls.

Recommended Boiler Water Temperatures

Type of Heating Unit	Limit Control Setting
Standing Radiators.....	180° F
Baseboard and Convactor Radiators.....	180° F

These settings can be changed after you have had some idea how the system works.

Example: If your system does not give quite enough heat in very cold weather, you can raise the limit setting to 190°F.

**Adjust Thermostat Heat Anticipator
Instructions For The Final Adjustment of
Thermostat Are Packaged With Thermostat.**

1. Set Heat anticipator at .2.
2. Check thermostat operation. When set above temperature indicated on the thermometer, boiler burners should ignite. Make certain the thermostat turns off the boiler when room temperature reaches the selected setting and starts the boiler operating when room temperature falls a few degrees. After setting limit control to desired setting, check to see if it shuts off the gas supply to the burners.
3. Turn your thermostat up to call for heat and let your boiler run until the temperature of the water reaches the limit setting. The gas valve should shut off and the circulator keep running until the thermostat is satisfied, or the water cools enough to restart the burners through the limit control.
4. To check the operation of the contacts in the pressure switch, disconnect the rubber tubing (located between the blower and the pressure switch) from the pressure switch, while the boiler is operating. The burners should extinguish and the blower should keep running. When the tubing is reconnected to the pressure switch, the ignition sequence should begin, resulting in ignition of the main burners.
5. Finally, set the thermostat for the desired temperature. Special conditions in your home and the location of the thermostat will govern this setting.

Safe lighting and other performance criteria were met with the gas manifold and control assembly provided on the boiler when the boiler underwent tests specified in ANSI Z21.13.

Burners

A visual check of the pilot and main burner flames should be made at least once each year, preferably at the beginning of the heating season. See **Figures 15, and 17.**

Figure 15 - Pilot Flame Adjustment

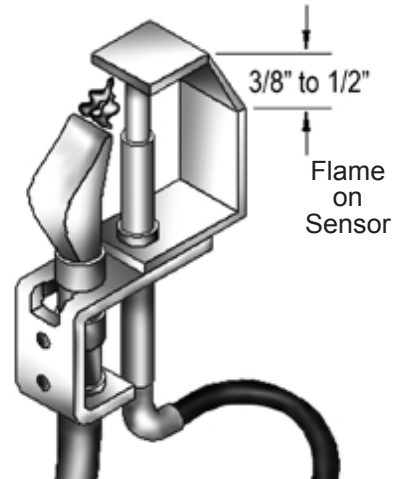

Figure 16 -Automatic Gas Valve

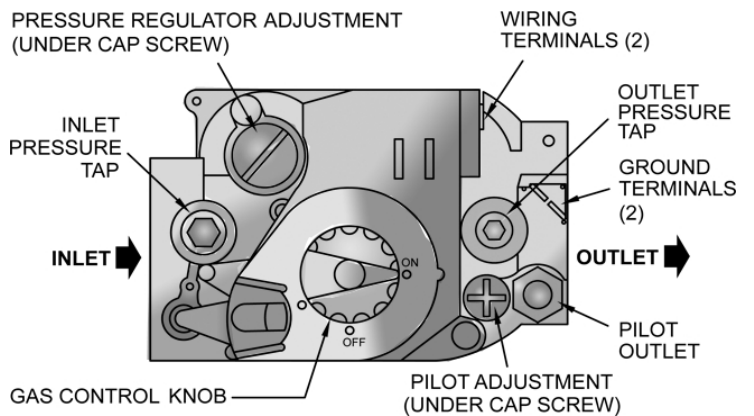
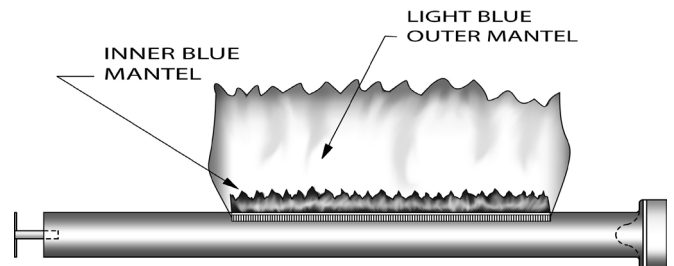

Figure 17 - Main Burner Flame



The main burner flame should form a sharp blue inner mantel with no yellow.

INITIAL OPERATIONAL BOILER TEST CHECK-OUT PROCEDURE

XEB Series Cast Iron Gas-Fired Cast Iron Boilers

- Check off each step as completed.
- Verify base insulation is securely fastened to base panels.
- Verify air purged from hydronic heating system.
- Purge air from gas piping; check gas piping for leaks.
- Verify proper orifices have been installed.
- Follow lighting instructions in series XEB installation, operation and maintenance manual furnished with boiler.
- Visually check the main burner flame and verify it has a well defined inner blue mantel with a lighter blue outer mantel.
- Inspect vent system to verify it is functional, unobstructed, and not leaking.
- Test the temperature limit control: With burner operating, adjust indicator on limit control below actual boiler water temperature. Verify burners turn off. Verify the circulator continues to operate. Adjust the indicator on limit control above actual boiler water temperature and verify burners reignite.
- Test any additional field-installed controls. If boiler has a low water cut-off or additional high limit, test for operation as outlined by the controls manufacturer. Burners should be operating and should go off when controls are tested. When controls are reset, burners should reignite.
- Ignition system safety shutoff must be tested after placing boiler in operation: with main burner operating, disconnect the ignition cable from the intermittent pilot control box. Verify that the main gas control closes, shutting off the gas to the main burner. After verifying safety control circuit, turn off electric power and reconnect ignition cable. Once ignition cable securely reset to intermittent pilot control box, turn electric power on.
- For multiple heating system zones, balance flow through each zone so that it is about equal per zone.
- Verify several operating cycles of proper operation.
- Measure gas input:

Natural Gas Procedure

- Operate boiler for 10 minutes.
- Turn off all other gas appliances piped with the boiler.
- At the gas meter, measure the cubic feet of gas used in 10 seconds (CF10).
- Calculate input: $Btuh = CF10 \times 360,000$
- Verify the Btuh is approximate to the input rating on the boiler rating plate.

LP Gas Procedure

- LP gas input rate is determined by measuring gases produced during combustion. Refer to Boiler Manual for combustion guidelines and corresponding BTU input.
- Verify the Btuh is approximate to the input rating on the boiler rating plate.

- Record the Btuh input on the OPERATIONAL BOILER TEST CERTIFICATE & SIGNED RECEIPT form.
- Set operating control (thermostat(s)) to the desired design requirement.
- Forward boiler manuals, instructions, wiring diagrams, piping diagrams, and supporting information shipped with this boiler to owner and/or maintenance personnel.
- Complete and sign the INITIAL OPERATIONAL BOILER TEST CERTIFICATE & SIGNED RECEIPT form.

INITIAL OPERATIONAL BOILER TEST CERTIFICATE & SIGNED RECEIPT

Boiler Manufacturer:
Dunkirk Boilers
85 Middle Road
Dunkirk, NY 14048

Boiler Identification:
Model #: _____
Serial #: _____

Measured BTUH input: _____ Operational Test Date: _____ / _____ / _____

- Installation Instructions in the XEB Installation, Operation and Maintenance Manual have been followed.
- Initial Operational Boiler Test Check-Out Procedure has been performed.
- Information on this form is certified to be correct.
- All boiler instructions, wiring diagrams, piping diagrams, and supporting information shipped with this boiler forwarded to owner/maintenance personnel.

Installation Location:

Customer Name: _____

Address: _____

City: _____ State: _____ Zip: _____

Installer Information

Company/Contractor: _____

Address: _____

City: _____ State: _____ Zip: _____

Telephone #: _____

Installer's Signature _____ Date: _____ / _____ / _____

Installer's Printed Name: _____

Relief Valve

This valve should open automatically if the system pressure exceeds the pressure rating (usually 30 psi) of the relief valve. Should it ever fail to open under this condition, shut down your system. Drain the system until system pressure is reduced below the relief valve pressure rating. If valve discharge occurs, or if valve fails to open as described above, contact an authorized contractor or qualified service technician to replace the relief valve and inspect the heating system to determine the cause, as this may indicate an equipment malfunction.

This valve should be tested every month during periods of boiler operation, and at the beginning and end of any extended non-service period. Prior to testing, make certain discharge pipe is properly connected to valve outlet and arranged so as to contain and safely dispose of boiler discharge. Test at normal system operating pressure. Hold the trip lever fully open for at least five seconds in order to flush free any sediment that may lodge on the valve seat. Then permit the valve to snap shut.

Expansion Tank

As previously noted, this tank may become waterlogged, or may receive an excess of air. Frequent automatic opening of the relief valve indicates water logging. A high boiler temperature accompanied by unusually low radiation unit temperature (and "knocking") indicates excess air in tank. To correct either condition, close the valve between the boiler and the tank. Drain the tank until it is empty. Check all the tank plugs and fittings. Tighten as necessary. Open the valve between the boiler and tank. Water will rise to the normal height in the tank if you have an automatic fill valve (otherwise, manually refill the system).

Boiler Flue Passages

Under normal operating conditions, with the burners properly adjusted, it should not be necessary to clean the boiler flue gas passages. However, to assure trouble-free operation, we recommend that you have the flue passages, burner adjustment, and operation of the controls checked once each year by a competent Service Technician.

Before The Start Of Each Season

(or whenever system has been shut down for some time) recheck the whole system for leaks . . . and recheck the boiler and vent pipe for leaks. Replace or patch any boiler seals that are faulty.

Vent Pipe

The venting of this unit is very important and the piping should be checked at least once a month. If the vent piping shows any sign of leaking, replace it immediately.

Water System

If system is to remain out of service during freezing weather, always drain it completely (water left in to freeze will crack the pipes and/or boiler).

Cleaning Your Boiler And Burners

Flue passages between sections should be examined yearly and cleaned if necessary.

To clean, remove burners, pilot and vent pipe. Remove top and front jacket panels. Split the silicone seal on the flue collector and the clean out plates with a razor knife. Remove flue collector. Remove clean out plates by tapping upwards on the bottom of the plate with a hammer. Remove loose silicone sealant from sections, flue collector, and clean out plates.

Clean passageways between sections with a flexible handle wire brush and a straightened out wire coat hanger. Remove dirt from the bottom of the boiler and from between sections by vacuuming.

Make sure all flame ports in burners are open and clear. Shake out or blow out all loose dirt in burners. Reassemble all parts. Seal flue collector and clean out plates to sections with silicone sealant (400° F RTV silicone sealant or equivalent). Reseal seams between adjacent sections where necessary. All joints must be airtight. Be sure to check tightness of pilot connections and condition of burner flames after reassembly (see **Figures 15, and 17**). Be sure vent pipe connections to chimney are secure and no obstructions are present.

Blower

The blower motor features a permanently lubricated ball bearing construction. Lubrication is not required.

Circulator Pump Isolation Valves

The isolation valves in the circulator pump flanges should be operated manually once or twice per year to prevent the valves from becoming stuck in the open position. Rotate the valves from the open position to the closed position and back to the open position.

Low Water Cutoff(s)

Inspect field sourced low water cutoffs annually or as recommended by low water cutoff manufacturer. Flush float type low water cutoff(s) per manufacturer's instructions.

General Housekeeping

Keep boiler area clear and free from combustible materials, gasoline and other flammable vapors and liquids.

SERVICE HINTS

You may avoid inconvenience and service calls by checking these points before you call for service:

WARNING

WHAT TO DO IF YOU SMELL GAS



Do not try to light any appliance.

Do not touch any electrical switches; do not use any phones in your building.

Immediately call your gas supplier from a neighbor's phone. Follow gas supplier's instructions.

If you cannot reach your gas supplier, call the fire department.

IF YOUR SYSTEM IS NOT HEATING OR NOT GIVING ENOUGH HEAT . . .

POSSIBLE CAUSE	WHAT TO DO
Thermostat is not set correctly	Reset thermostat
Burner is not operating properly	Check flame. If it is yellow, the burner is not getting enough air. Or, if flame is blue and noisy and seems to lift off the burner, the burner is getting too much air. Contact your service technician.
No electric power to boiler	Check over-current protection. Check to be sure electric power supply circuit is "ON".
Controls out of adjustment	Reset according to instructions.
Radiators not heating	Open radiator vents to excess air. Check flow control valve (if used). It may be in closed position.
Circulating pump not running	Check over-current protection. Check relay operation.
Poor electrical contact	Check all control terminals and wire joints.
Chimney flue is blocked	Pressure switch will not close and pilot spark will not operate to start pilot. Have your service technician check and correct, if necessary.
Rollout switch blown	Have your service technician check heat exchanger for blockage. Replace rollout switch with exact replacement.

IF BURNER IS NOISY . . .

POSSIBLE CAUSE	WHAT TO DO
Gas input amount is incorrect	Contact your service technician.

RELIEF VALVE LEAKING . . .

POSSIBLE CAUSE	WHAT TO DO
Dirt on seat	Open valve manually. Allow water to run and clear valve seat.
Water logged expansion tank	Drain tank, see instructions.

HAVE YOUR SERVICE TECHNICIAN CHECK ANY PROBLEM YOU ARE UNABLE TO CORRECT.

Date	Service Performed	Company Name & Tech Initials	Company Address & Phone #

Gas-Fired Hot Water Induced Draft Boilers

REPAIR PARTS & OPTIONAL KITS

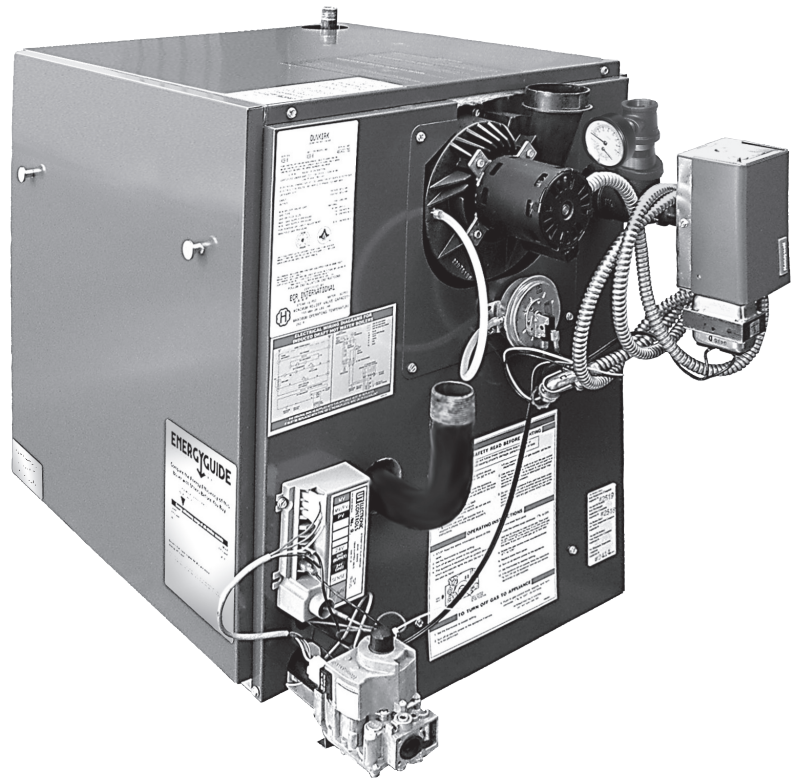

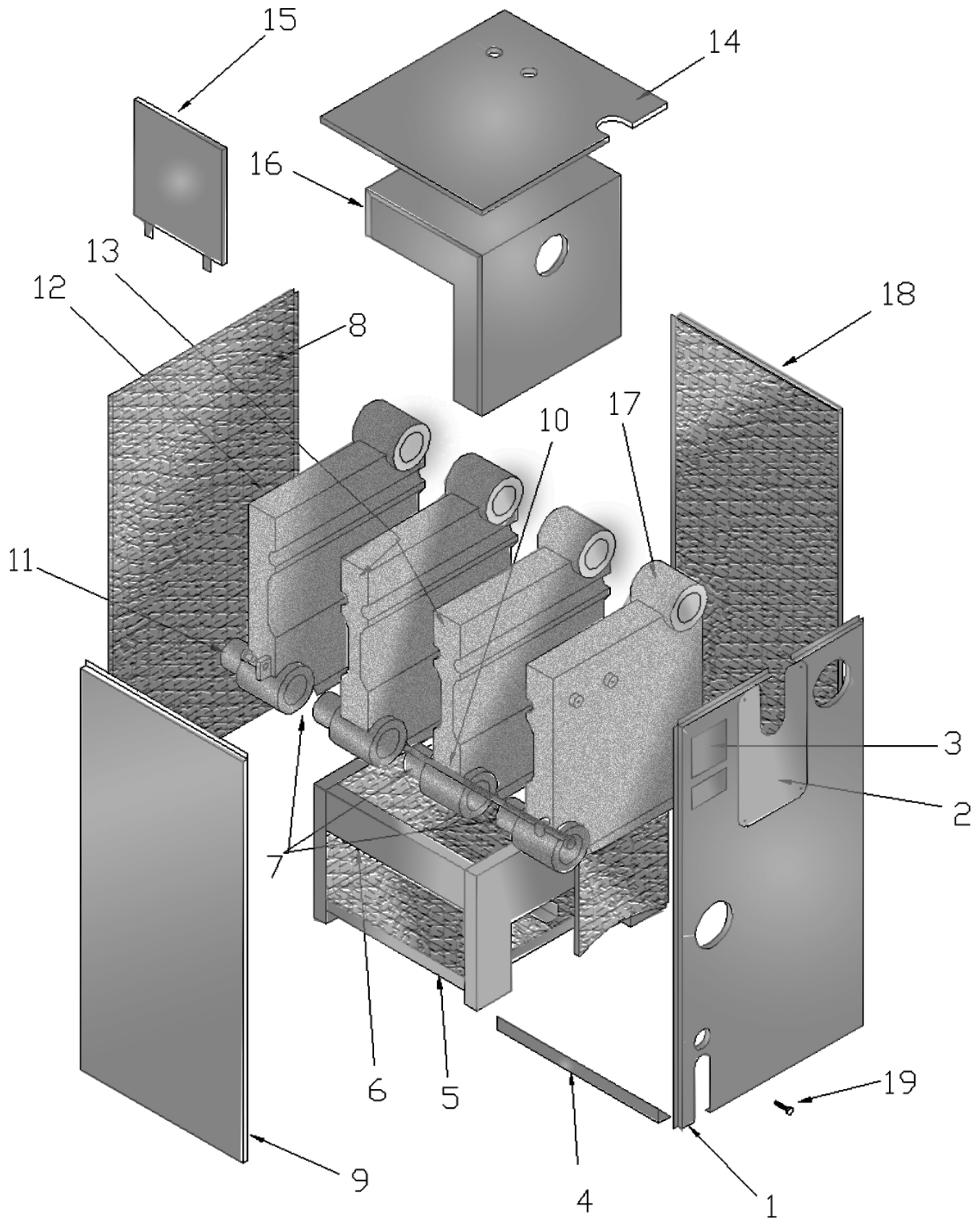
Jacket Sections and Base Parts

Jacket Sections and Base Parts

KEY NO.	DESCRIPTION	PART NUMBERS FOR					
		2 Section	3 Section	4 Section	5 Section	6 Section	7 Section
1	Jacket, Right Side Panel	730001050	730001050	730001050	730001050	730001050	730001050
2	Blower Cover Plate	630001170	630001170	630001170	630001170	630001170	630001170
3	Rating Plate	240004760	240004760	240004760	240004760	240004760	240004760
4	Jacket Tie Bar	42500653	42500654	42500655	42500656	42500657	42500658
5	Boiler Base	42500733	42500734	42500735	42500736	42500737	42500738
6	Insulation, Base Side (2 Required)	14614020	14614020	14614020	14614020	14614020	14614020
6	Insulation, Base Front	14614112	14614113	14614114	14614115	14614116	14614117
6	Insulation, Base Rear	14614122	14614123	14614124	14614125	14614126	14614127
7	Nipple, Boiler	43300976	43300976	43300976	43300976	43300976	43300976
8	Jacket, Left Side Panel	730001040	730001040	730001040	730001040	730001040	730001040
9	Jacket, Front Panel	730001032	730001033	730001034	730001035	730001036	730001037
10	1/4" Tie Rod, (2 Required)	14605008	14605002	14605002	14605051	14605053	14605008
11	Nut & Washer	1330002	1330002	1330002	1330002	1330002	1330002
12	Section, Left End	41000019	41000019	41000019	41000019	41000019	41000019
13	Section, Intermediate		41001018	41001018	41001018	41001018	41001018
14	Jacket, Top Panel	730001012	730001013	730001014	730001015	730001016	730001017
15	Cleanout Plate(s) & Insulation	42501539	42501540	42501541	42501542	42501540 & 42501541	42501541 (x2)
16	Flue Collector	730003002	730003003	730003004	730003005	730003006	730003007
17	Section, Right End	41000017	41000017	41000017	41000017	41000017	41000017
18	Jacket, Back Panel	730001022	730001023	730001024	730001025	730001026	730001027
‡	Jacket, Complete	730001002	730001003	730001004	730001005	730001006	730001007
19	#10 x 1/2 Sheet Metal Screw	14695074	14695074	14695074	14695074	14695074	14695074
‡	Block Assembly (7,10,11,12,13,17))	41000212	41000312	41000412	41000512	41000612	41000712
‡	Combustible Floor Plate	14614031	14614031	14614031	14614031	14614032	14614032

‡ Not illustrated

Boiler Controls and Piping Repair Parts

NOTE: Circulator and ball valves do not come pre-installed.

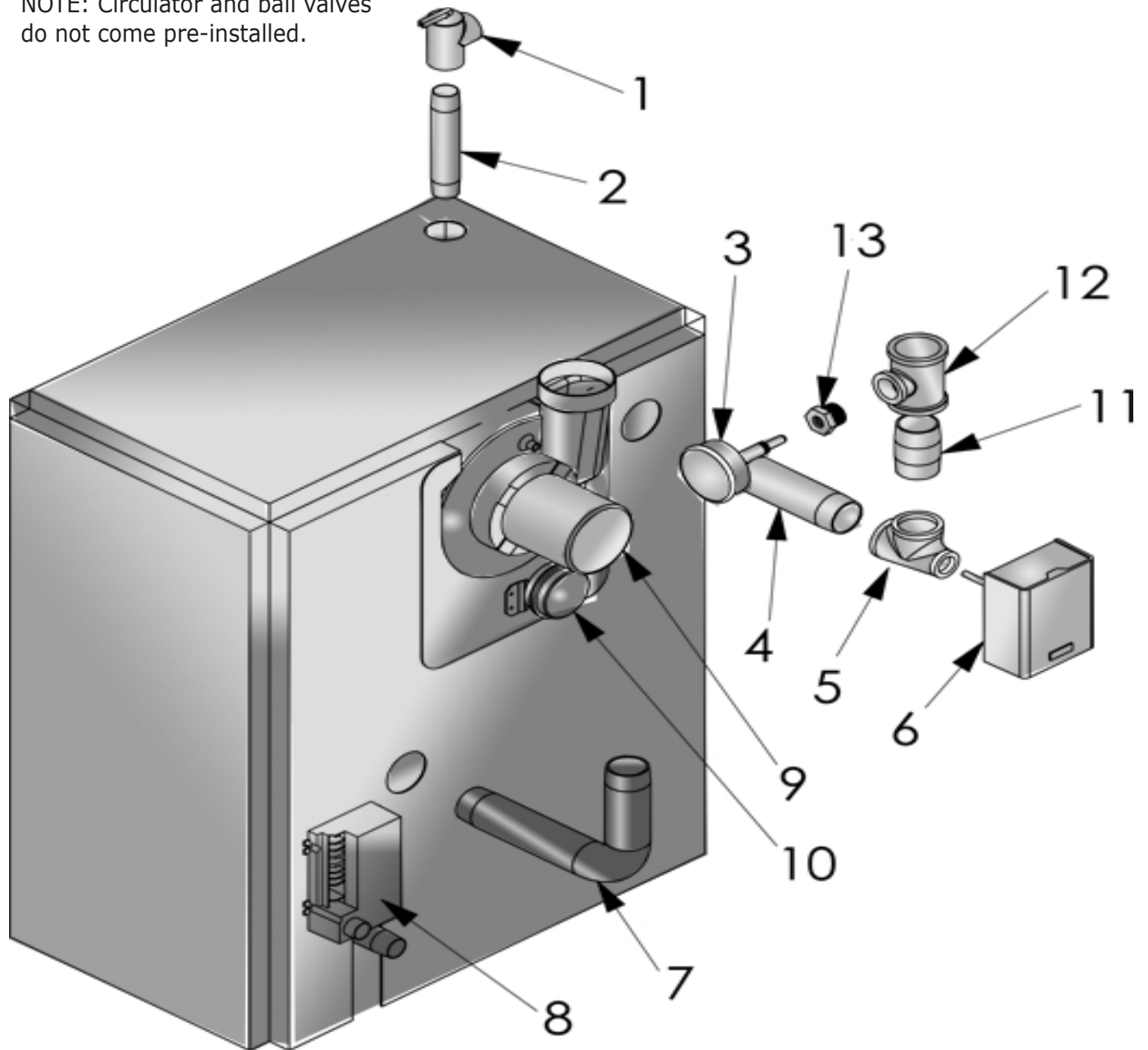

Boiler Controls and Piping Repair Parts

Key No.	Description	Part No.
1	¾" ASME Relief Valve	14622011
2	¾" x 5½" Nipple	1310010
3	Temperature Pressure Gauge - (3½" Stem)	1260006SP
4	1¼" x 5½" Nipple	14607019
5	1¼" x ¾" x 1¼" Tee	1510001
6	L8148A Comb Hi Limit & Relay Control	43300521
7	1¼" Return Nipple	14607004
8	Intermittent Pilot Control	14662070
9	Induced Draft Blower and Gasket	2272159
10	Pressure Switch - 2,3,4,5, Section	14655006
	Pressure Switch - 6,7, Section	14655005
11	Nipple 1¼" x 2½"	14607044
12	Tee 1¼" x 1¼" x ¾"	PF05901
13	Bushing ¾" x ¼"	1060002
‡	Taco Pump 007	CI-001.03
‡	Isolation Ball Valve	14626038
‡	Rubber Tube (Blower to Pressure Switch)	1552014
‡	Rollout Switch	14629002
‡	1¼" x ¾" Bushing	1060003
‡	AT 140C 24 V. Transformer	14662080
‡	3" x 4" Increaser Fitting - Galvanized	14628012
‡	400°F Black Silicone Rubber Adhesive Sealant (10.1 oz. Cartridge)	240006837
‡	500°F Red Silicone Rubber Adhesive Sealant (10.3 oz. Cartridge)	240006502

‡ Not illustrated

Natural Gas Valve

FOR USE WITH
NATURAL GAS ONLY

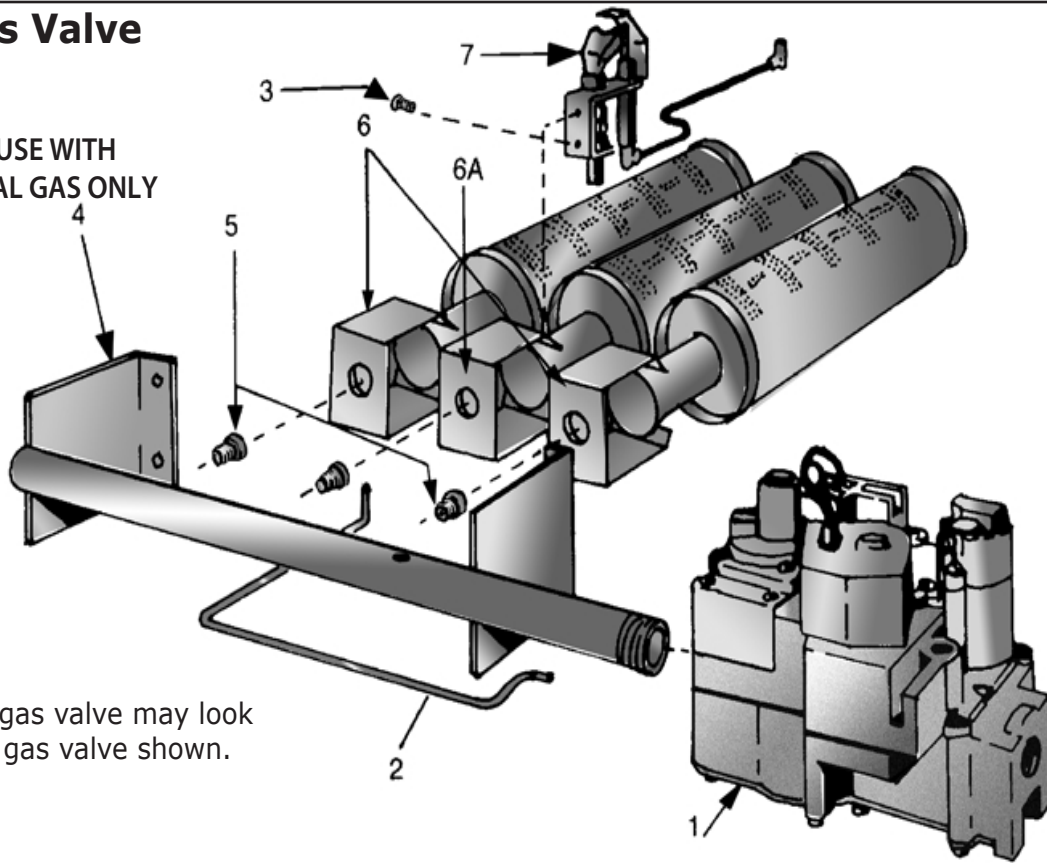

NOTE: Actual gas valve may look different than gas valve shown.

NATURAL GAS BURNER & MANIFOLD PARTS							
KEY NO.	DESCRIPTION	PART NUMBERS FOR					
		2 Section	3 Section	4 Section	5 Section	6 Section	7 Section
1	24 Volt Gas Valve, Natural Gas	14662052	14662052	14662052	14662052	14662058	14662058
2	Pilot Tube With Fitting	43300201	43300201	43300201	43300201	43300200	43300200
3	10-32 x 3/16" Slotted Hex Head Screws	14695301	14695301	14695301	14695301	14695301	14695301
4	Gas Manifold	14616042	14616043	14616044	14616045	14616024	14616025
5	Orifice -Natural Gas*	14615030	14615031	14615031	14615031	14615035	14615035
6	Main Burner Less Pilot Bracket**	- - -	14615532	14615532	14615532	14615532	14615532
6A	Main Burner with Pilot Bracket	14615531	14615531	14615531	14615531	14615531	14615531
7	Pilot Burner with Orifice, Natural Gas	14662100	14662092	14662092	14662092	14662092	14662092
‡	Rollout Shield	42500932	42500933	42500934	42500935	42500936	42500937

*Requires 1 less than the number of sections.

**Requires 2 less than the number of sections.

‡ Not illustrated.

Quantity is 1 unless otherwise noted.

Propane Gas Valve

For Use With
Propane Gas Only

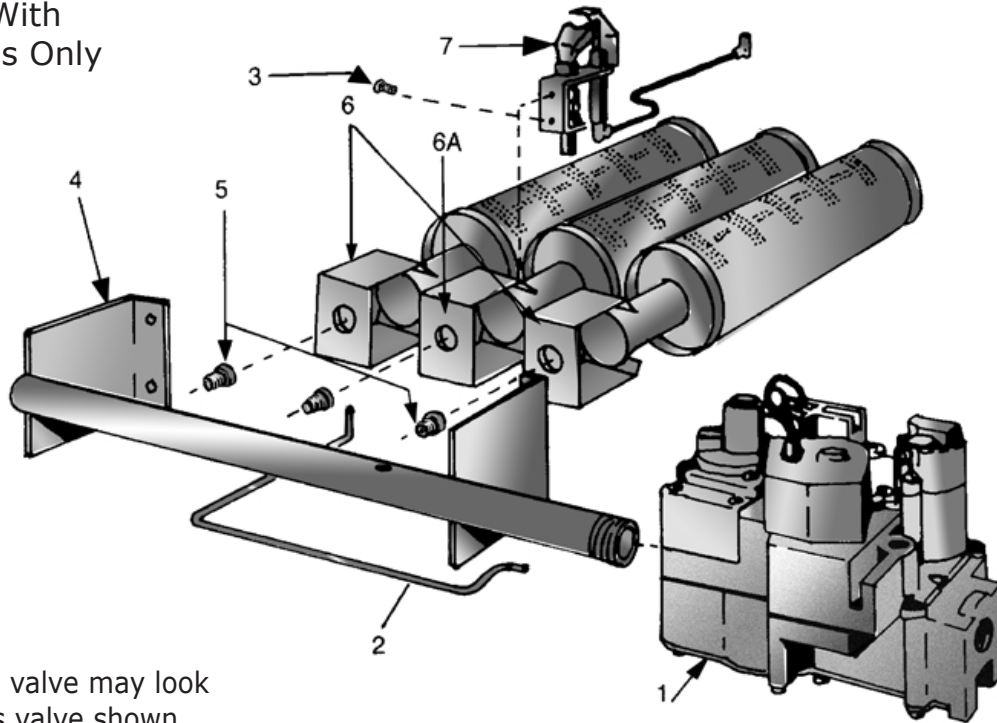

NOTE: Actual gas valve may look different than gas valve shown.

PROPANE GAS BURNER & MANIFOLD PARTS							
KEY NO.	DESCRIPTION	PART NUMBERS FOR					
		2 Section	3 Section	4 Section	5 Section	6 Section	7 Section
1	24 Volt Gas Valve, Propane Gas	14662062	14662062	14662062	14662062	14662059	14662059
2	Pilot Tube With Fitting	43300201	43300201	43300201	43300201	43300200	43300200
3	10-32 x 3/16" Slotted Hex Head Screws	14695301	14695301	14695301	14695301	14695301	14695301
4	Gas Manifold	14616020	14616021	14616022	14616023	14616024	14616025
5	Orifice-Propane Gas*	14615044	14615036	14615036	14615036	14615036	14615036
6	Main Burner Less Pilot Bracket**	---	14615532	14615532	14615532	14615532	14615532
6A	Main Burner with Pilot Bracket	14615531	14615531	14615531	14615531	14615531	14615531
7	Pilot Burner with Orifice, Propane Gas	14662093	14662094	14662094	14662094	14662094	14662094
‡	Rollout Shield	42500932	42500933	42500934	42500935	42500936	42500937

*Requires 1 less than the number of sections.
**Requires 2 less than the number of sections.

‡ Not illustrated.
Quantity is 1 unless otherwise noted.

ORDERING INSTRUCTIONS

Order Parts through your nearest supplier.

When ordering parts, first obtain Model Number from data plate on your boiler.

Include following information when ordering:

Part No. _____

Part Description _____

Boiler Model No. _____



PRODUCT LITERATURE
Lennox Industries Inc.
Dallas, Texas