



**PRODUCT LITERATURE**

Lennox Industries Inc.  
Dallas, Texas

# INSTALLATION INSTRUCTIONS

---

## **COWB2 OIL FIRED BOILER**

---

*BOILERS 456,983M*

**RETAIN THESE INSTRUCTIONS FOR  
FUTURE REFERENCE**

***These instructions must be  
affixed on or adjacent to the boiler.***



### **OIL FIRED BOILERS**

These boilers are low pressure, sectional cast iron boilers constructed and hydrostatically tested for a maximum working pressure of psi in accordance with A.S.M.E. (American society of Mechanical Engineers) Section IV Standards for cast iron heating boilers. They are capacity rated in accordance with the code of the I=B=R (Hydronics Institute).



## INTRODUCTION

The Empire Water boiler is a natural draft oil fired hot water boiler comprised of cast iron sections. The Empire Water boiler is available with 3, 4, or 5 cast iron sections. These sections are held together by cast iron push nipples.

The Empire Water boiler is capable of firing #2 fuel oil from 0.65 gph up to 2.00 gph. All packaged

boilers include a swing door, Honeywell aquastat, temperature and pressure gage, relief valve, drain valve, 2 Delevan oil nozzles for multiple firing rates (only when purchasing a burner), flue brush, and an extra boiler tap for an expansion tank or air elimination.

## BOILER RATINGS AND CAPACITIES

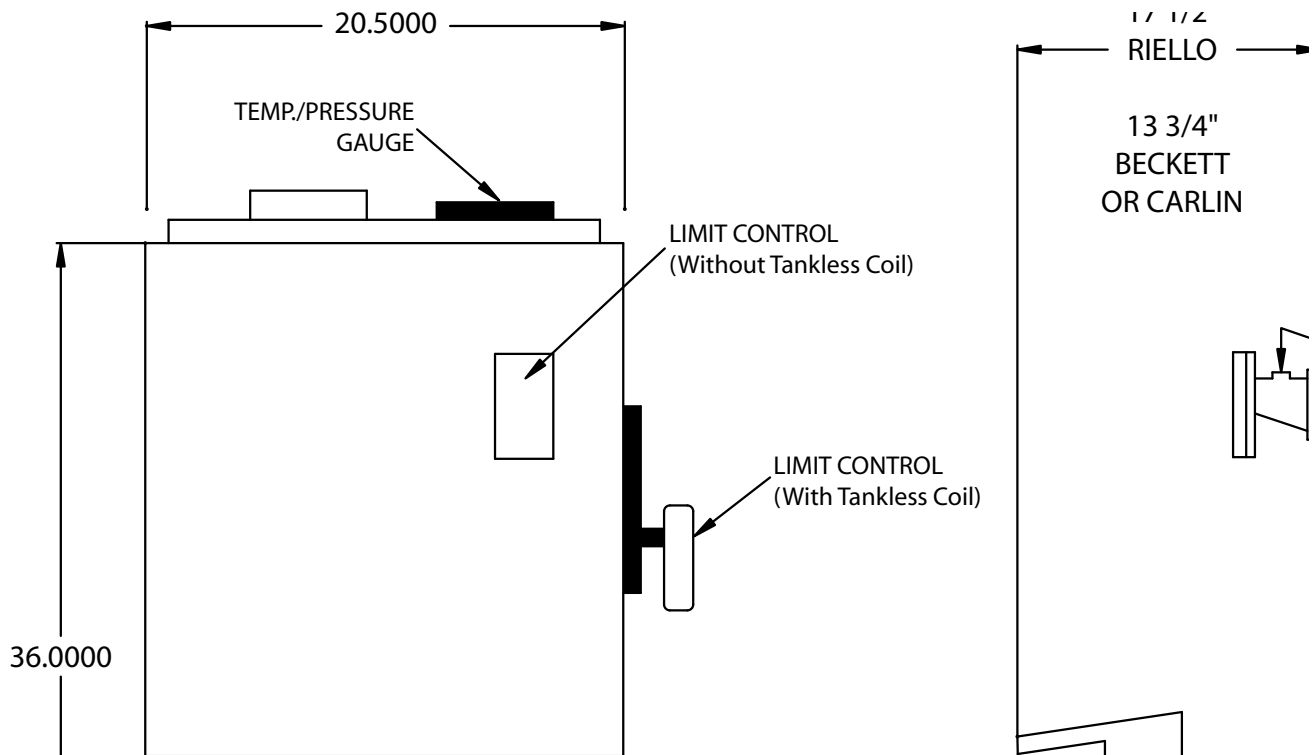

BOILER MODEL NO. <i>Without Tankless Coil</i>	NO. SEC.	INPUT *MBH	**HEATING CAPACITY *MBH	NET I=B=R RATING *MBH	FIRING RATE +GPH	A.F.U.E. ++	MINIMUM CHIMNEY SIZE/HEIGHT	DIMENSIONS (inches)		
								A	B	C
COWB23.65Z	3	91	80	70	0.65	86.3	8" X 8" X 15"	14 1/2	6	8
COWB23.75Z	3	105	92	80	0.75	85.2	8" X 8" X 15"	14 1/2	6	8
COWB231.00Z	3	140	119	103	1.00	83.4	8" X 8" X 15"	14 1/2	6	8
COWB24.90Z	4	126	111	97	0.90	86.0	8" X 8" X 15"	17 3/4	6	95/8
COWB241.25Z	4	175	150	130	1.25	83.9	8" X 8" X 15"	17 3/4	6	95/8
COWB241.50Z	4	210	178	155	1.50	82.4	8" X 8" X 15"	17 3/4	6	95/8
COWB251.20Z	5	168	147	128	1.20	86.5	8" X 8" X 15"	21	6	111/2
COWB251.75Z	5	245	209	182	1.75	83.6	8" X 8" X 15"	21	6	111/2
COWB252.00Z	5	280	236	205	2.00	82.0	8" X 8" X 20"	21	6	111/2

\*MBH = 1,000 BTU per hour

BTU = British Thermal Unit

\*\*Heating Capacity based on 13% CO<sub>2</sub> with a 0.02" w.c. draft over fire, and a #1 smoke or less. Testing was done in accordance with the D.O.E. (Department of Energy) test procedure.

+GPH = Gallons per hour oil at 140,000 BTU per gallon

++A.F.U.E. = Annual Fuel Utilization Efficiency based upon D.O.E. test procedure.

## BOILER RATINGS AND CAPACITIES

These low pressure oil fired hot water boilers are constructed and hydrostatically tested for a maximum working pressure of 50 psig (pounds per square inch gage) in accordance with A.S.M.E. (American Society of Mechanical Engineers) Boiler and Pressure Vessel Code Section IV Standards for heating boilers.

The **Heating Capacity** indicates the amount of heat available after subtracting the losses up the stack. Most of this remaining heat is available to heat water. A small portion is heat from the jacket and surfaces of the boiler and it is assumed that this heat stays in the structure. The Net I=B=R Rating represents the portion of the remaining heat that can be applied to heat the radiation or terminal units (i.e. finned tube baseboard, cast iron radiators, radiant floor, etc.). The difference between the Heating Capacity and the Net I=B=R Rating, called the piping and pickup allowance, establishes a reserve for heating the volume of water in the system and offsetting heat losses from the system piping. The Net I=B=R Ratings shown are based on a piping and pickup factor of 1.15 in accordance with the I=B=R Standard as published by the Hydronics Institute. The **Net I=B=R Rating** of the boiler selected should be greater than or

equal to the calculated peak heating load (heat loss) for the building or area(s) served by the boiler and associated hot water heating systems. The manufacturer should be consulted before selecting a boiler for installations having unusual piping and pickup requirements.

Boilers with the same number of sections are identical to each other except for their firing rate. The firing rate is determined by the nozzle size in the oil burner and the oil pressure at the nozzle. For example: Models 3E.65Z, 3E.75Z, and 3EI.00Z are the same boiler, without a tankless coil, except for the firing rate of the oil burner.

Each boiler rating plate shows three possible model numbers for a given boiler configuration. The actual model number is determined by the firing rate of the oil burner. Boilers that are factory packaged include two nozzles for two firing rates. These boilers operate on #2 Heating Oil. This fire rate does not come with additional nozzles or heads for the burner. The 3 & 4 section units are packaged with two nozzles. They can be field converted to low fire rates by utilizing the low fire kit.

## RULES FOR SAFE INSTALLATION AND OPERATION

1. Read the Owner's Manual for Safe Operation carefully. Failure to follow the rules for safe operation and the instructions can cause a malfunction of the boiler and result in death, serious bodily injury, and/or property damage.
2. Check your local codes and utility requirements before installation. The installation must be in accordance with their directives, or follow NFPA 31 Installation of Oil Burning Equipment, latest revision.
3. Before servicing, allow boiler to cool. Always shut off any electricity and oil to boiler when working on it.
4. Inspect oil line and connections for leaks.
5. Be certain oil burner nozzle is the size required. Over-firing will result in early failure of the boiler sections. This will cause dangerous operation.
6. Never vent this boiler into an enclosed space. Always vent to the outside. Never vent to another room or inside a building.
7. Be sure there is adequate air supply for complete combustion.
8. Follow a regular service and maintenance schedule for efficient and safe operation.
9. Keep boiler area clean and free of combustible material, gasoline and other flammable vapors and liquids.
10. Oil burners are not do-it-yourself items. This boiler must be installed and serviced by qualified professionals using combustion test instruments.
11. Be aware when piping the relief valve that if the system pressure exceeds the safe limit of 30 pounds per square inch, the relief valve will automatically lift open. Lifting of the relief valve can discharge large quantities of steam and hot water, which may damage the surroundings. Before installing the relief valve read the manufacturer's instructions and maintenance section of the manual on relief valves.
12. Installation and sizing of the expansion tank must consider the heating systems total water volume, temperature, boiler initial fill pressure, and system arrangement. An improperly installed and sized expansion tank may result in frequent lifting of the relief valve or other heating system problems. For proper installation, sizing, and maintenance of the expansion tank follow the guidelines established by Dunkirk Boilers and the expansion tank manufacturer.
13. Expansion tank performance and life expectancy can be hindered by overfilling the boiler. Dunkirk Boilers recommends an initial fill pressure of 10-12 psig. For higher fill pressures the expansion tank's air charge will need to be increased to match the fill pressure. Consult the manufacturer's guidelines for sizing and selection.
14. Purging the heating system of air and gases when first putting the boiler into service is critical for proper circulation and quiet performance. Once the air and gases are purged, for boiler installations using float type vents, the air vents should be closed for normal operation. If air is heard or noticed by a loss of heat, purge the system and open the vents for a short period of time.

### **WARNING**

***This boiler has been designed for residential installations. If used for commercial applications, all jurisdictional requirements must be met. This may require wiring and/or piping modifications. The manufacturer is not responsible for any changes to the original design.***

**DO NOT USE GASOLINE CRANKCASE DRAININGS OR ANY OIL CONTAINING GASOLINE.**

## BEFORE YOU START

Complete all of the following prior to installing the boiler.

- A. Check to be sure you have selected the right size boiler with the proper capacity. The I=B=R rating of the boiler selected should be greater than or equal to the calculated peak heating load (heat loss) for the building or area(s) served by the boiler and associated hot water heating systems. See boiler rating and capacity table previously listed in this manual. Any heat loss calculations used should be based on approved methods.
- B. Boiler must be supplied with the proper oil supply and oil piping, sufficient fresh combustion air, and a suitable electrical supply.
- C. Boiler must be connected to a suitable venting system and a piping system adequate to distribute the heating load.
- D. A thermostat must be properly located and installed for control of the heating system.

If there are any doubts as to the various requirements, check with local authorities and obtain professional help where needed. The **OPERATING INSTRUCTIONS**, **FINAL CHECKS AND ADJUSTMENTS**, and **MAINTENANCE** sections in this manual are vital to the proper and safe operation of the heating system. Take the time to be sure they are all done.

## LOCATING THE BOILER

1. Place the boiler in a location centralized with the piping system and as close to the chimney as possible.
2. The boiler must be level. If necessary use metal shims beneath the boiler's feet.
3. Use a raised base if the floor can become wet or damp.
4. Maintain clearances for fire safety as well as servicing. An 18" clearance must be maintained at a side where passage is required for access to another side for cleaning, servicing, inspection, or replacement of any parts that normally may require such attention. Boilers must be installed at least 6" from combustible material on all sides and above. Allow at least 24" front clearance for servicing.
5. Fresh air for combustion must be available at the front of the boiler. Fresh air for ventilation must be available to the front **and** rear of the boiler. Air passages must be free of obstructions at all times. Ventilating and combustion air must enter boiler room without restrictions.
6. The floor supporting the boiler must be noncombustible and sufficiently stable. If it is combustible, place the boiler on 2" concrete patio blocks or 2" Cladlite Pad™. The blocks or pad must be under the entire boiler to protect the floor.
7. Be sure installation is in accordance with the requirements of the local authorities having jurisdiction. Compliance with these regulations is required. In the absence of local codes, follow NFPA 31 Installation of Oil Burning Equipment, latest revision.

## MINIMUM CLEARANCE DIMENSIONS

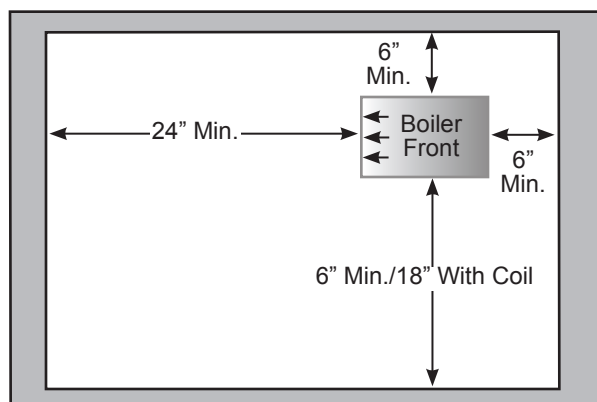

BOILER CLEARANCES			
Unit	Combustible Clearance	Accessibility, Cleaning, and Servicing	Flue to Combustible Clearance
Top	6"	18"	18"
Left Side	24"	24"	
Right Side	6"		
Base	noncombustible		
Front	18"		
Back	6"		

All distances measured from the cabinet of the boiler.

# INSTALLATION REQUIREMENTS

**ALWAYS KEEP THE MANUAL FUEL SUPPLY VALVE SHUT OFF, IF THE BURNER IS SHUT DOWN FOR AN EXTENDED PERIOD OF TIME.**

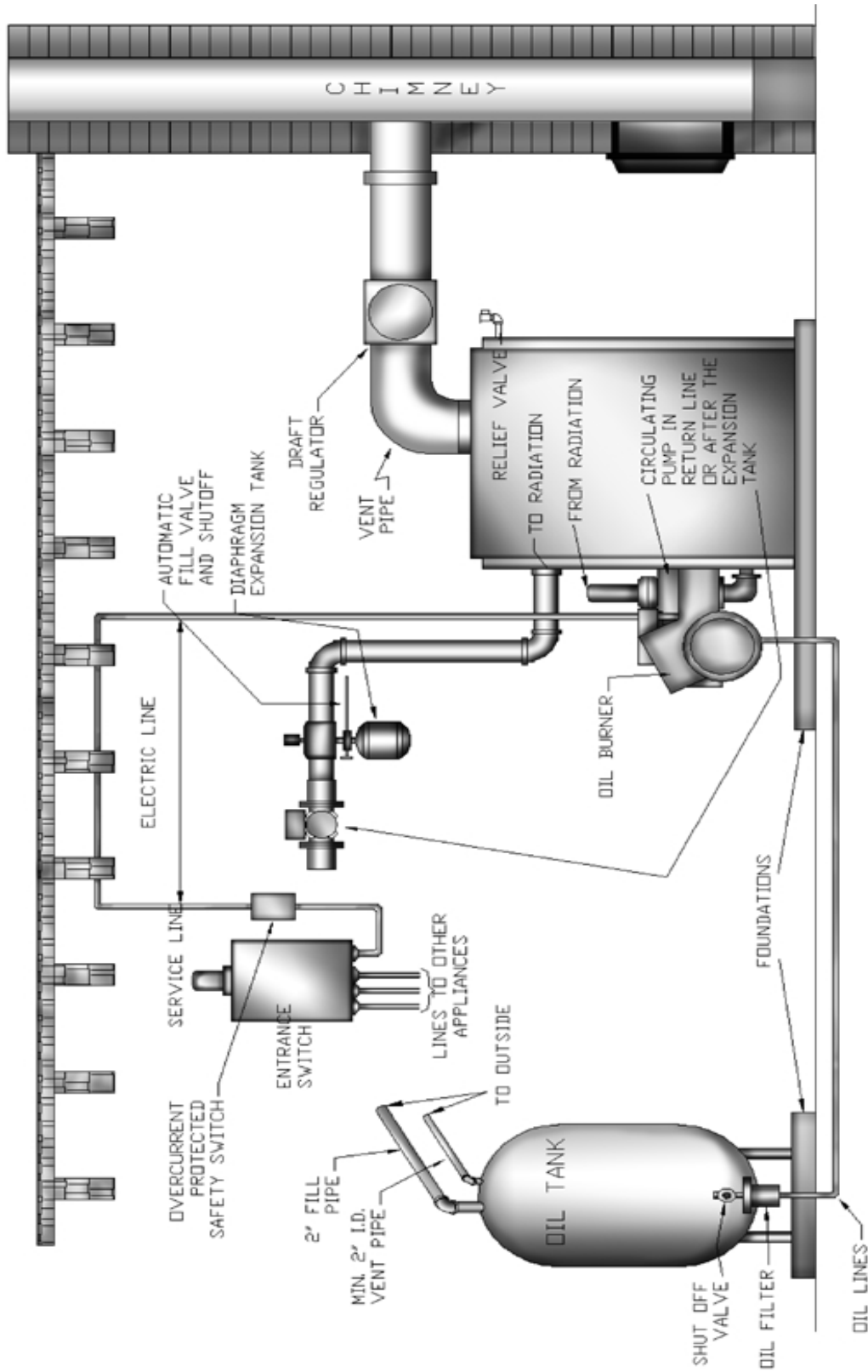

GENERAL PRINCIPAL REQUIREMENTS FOR A TYPICAL INSTALLATION



## FRESH AIR FOR COMBUSTION

### ⚠ WARNING ⚠

Be sure to provide enough fresh air for combustion. Enough air ensures proper combustion and assures that no hazard will develop due to the lack of oxygen.

**NOTE:** If you use a fireplace or a kitchen or a bathroom exhaust fan, you should install an outside air intake. These devices will rob the boiler and water heater of combustion air.

You must provide enough fresh air to assure proper combustion. The fire in the boiler uses oxygen. It must have a continuous supply. The air in the house contains only enough oxygen to supply the burner for a short time. Outside air must enter the house to replace the air used by the burner. Study the following examples 1 and 2 to determine your fresh air requirements.

### EXAMPLE 1: Boiler Located in Unconfined Space

If your boiler is in an open area (un-partitioned basement) in a conventional house, the air that leaks through the cracks around the doors and windows will usually be adequate to provide air for combustion. The doors should not fit tightly. Do not caulk the cracks around the windows.

An unconfined space is defined as a space whose volume is not less than 50 cubic feet per 1,000 Btu per hour of the total input rating of all appliances installed in that space.

### EXAMPLE 2: Boiler Located in Confined Space

**A. All Air from Inside the Building:** The confined space shall be provided with two permanent openings communicating directly with an additional room(s) of sufficient volume so that the combined volume of all spaces meets the criteria for an unconfined space. The total input of all combustion equipment installed in the combined space shall be considered in making this determination. Each opening shall have a minimum free area of one square inch per 1,000 Btu per hour of the total input rating of all combustion equipment in the confined space, but not less than 100 square inches. One opening shall be within 12 inches of the top and one within 12 inches of the bottom of the enclosure.

Example: Your boiler is rated at 100,000 Btu per hour. The water heater is rated at 30,000 Btu per hour. The total is 130,000 Btu per hour. You need two grilles, each with 130 square inches of **FREE** opening. Metal grilles have about 60% **FREE** opening. To find the louvered area needed, multiply the free opening required by 1.7 ( $130 \times 1.7 = 221.0$  sq. in. louvered area). In this example, two grilles each having an 8" x 30" (240 sq. in.) louvered area would be used.

### AIR OPENINGS FOR BOILER LOCATED IN CONFINED SPACE (Closet or Utility Room)

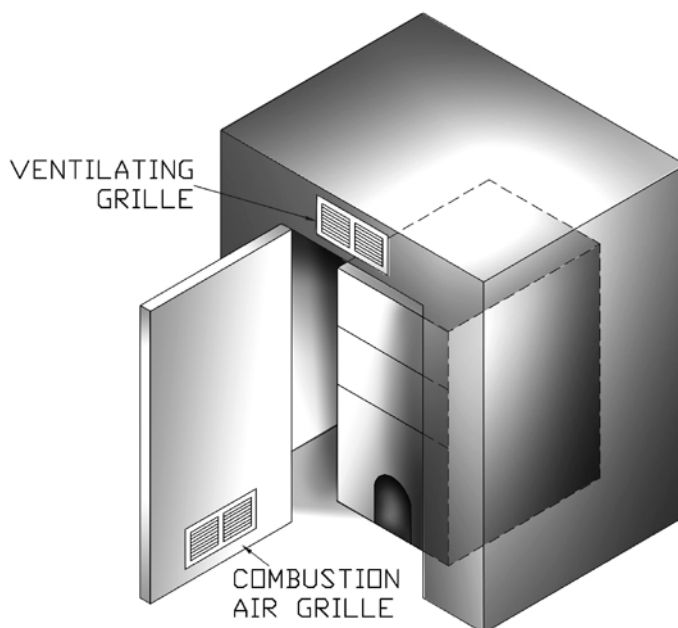

## FRESH AIR FOR COMBUSTION

**B. All Air from Outdoors:** The confined space shall be provided with two permanent openings, one commencing within 12 inches of the top and commencing within 12 inches of the bottom of the enclosure. The openings shall communicate directly, or by ducts, with the outdoors or spaces (crawl or attic) that freely communicate with the outdoors.

1. When directly communicating with the outdoors, each opening shall have a minimum free area of one square inch per 4,000 Btu per hour of total input rating of all equipment in the enclosure.
2. When communicating with the outdoors through vertical ducts, each opening shall have a minimum free area of one

square inch per 4,000 Btu per hour of total input rating of all equipment in the enclosure.

3. When communicating with the outdoors through horizontal ducts, each opening shall have a minimum free area of one square inch per 2,000 Btu per hour of total input rating of all equipment in the enclosure.
4. When ducts are used, they shall be of the same cross sectional area as the free area of the openings to which they connect. The minimum dimension of rectangular air ducts shall be not less than three inches.

## FRESH AIR DUCT CAPACITIES FOR DUCTS SUPPLYING FRESH AIR TO BOILER IN TIGHTLY CONSTRUCTED HOUSES

FRESH AIR DUCT CAPACITIES THROUGH LOUVERS			
Fresh Air Duct Size	1/4" Mesh Screen	Wood Louvers	Metal Louvers
	(Btuh)*	(Btuh)*	(Btuh)*
3 1/2" x 12"	144,000	36,000	108,000
8" x 8"	256,000	64,000	192,000
8" x 12"	384,000	96,000	288,000
8" x 16"	512,000	128,000	384,000

*\*Btuh = British Thermal Units per hour based on opening covered by 1/4" mesh screen, wood louvers, or metal louvers.*

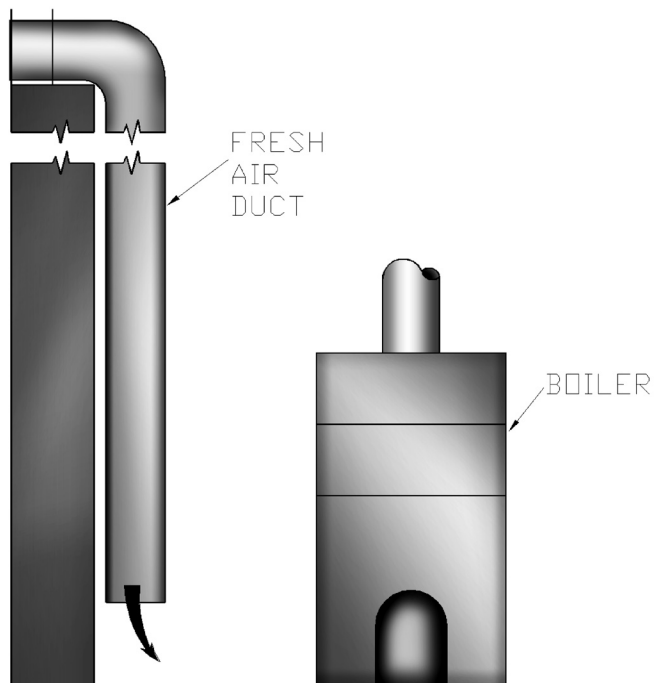



## SYSTEM PIPING

1. **When the installation of the boiler is for a new heating system**, first install all of the radiation units (panels, radiators, baseboard, or tubing) and the supply and return mains. After all heating system piping and components have been installed, make final connection of the system piping to the boiler. It is recommended to mount the circulating pump on the supply side piping, such that it pumps away from the expansion tank. Refer to the figures on the next pages.
2. A hot water **boiler installed above radiation level** must be equipped with a low water cut off device. A periodic inspection is necessary, as is flushing of float type devices, per low water cut off manufacturer's specific instructions.
3. The **packaged boiler unit is set up with 1 1/4" NPT supply and return piping** from the front of the boiler. The boiler supply and return piping can be moved to the rear of the boiler. The boiler should not be piped return line to the front, supply line to the rear, or vice versa, as this will cause the boiler water to short circuit the heat exchanger. Piping connections may require additional fittings and parts.
4. **The relief valve** is meant to be installed in the back side of the rear section using the 3/4" nipple and street ell provided in the parts bag. Connect a discharge pipe of the same pipe size (3/4") to carry any water away to a drain. Do not connect directly to a drain, but leave an air gap. No shutoff of any description shall be placed between the safety relief valve and the boiler, or on discharge pipes between such safety valves and the atmosphere. Installation on the safety relief valve shall conform to the ANSI/ASME Boiler and Pressure Vessel Code, Section IV. The manufacturer is not responsible for any water damage.
5. **When connecting the cold water supply** to the pressure reducing valve, make sure that a clean water supply is available. When the water supply is from a well or pump, a sand strainer should be installed at the pump.

## Low Design Water Temperature Systems (Below 140° F) And Large Water Content Systems

### ⚠ WARNING ⚠

Significant condensation may form in this boiler and/or the venting system if the boiler is operated with return temperatures of less than 120° F.

This condensation is corrosive and can eventually cause severe damage to the boiler and venting system. The minimum design return water temperature to prevent this condensation in the boiler and venting is 120°F. The minimum high limit setting is 140°F.

If the boiler is to be used in a heating system where design water temperatures below 140°F are desired (e.g. radiant floor heating), a 3way or 4way mixing valve or suitable alternative (e.g. bypass piping, **Figure A**) is required to prevent low temperature (below return 120°F) return water from entering the boiler. When using a mixing valve, follow the manufacturer's installation instructions.

If the boiler is to be connected to a system having a large water content (such as a former gravity system), it is suggested to use bypass piping shown in **Figure A**.

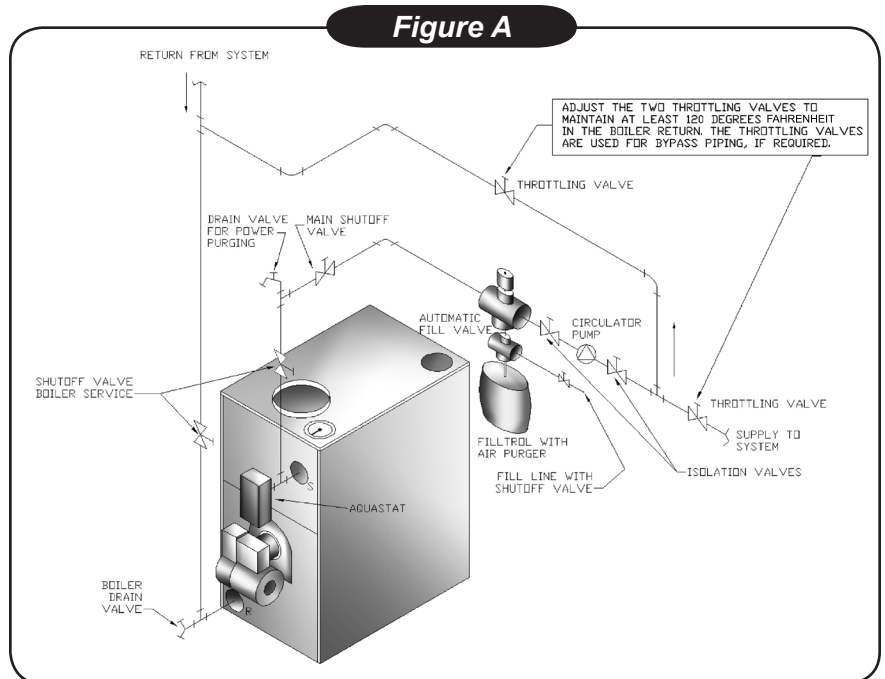

# SYSTEM PIPING ARRANGEMENT ZONING WITH ZONE VALVES

- > CIRCULATOR ON SUPPLY PIPING PUMPS AWAY FROM EXPANSION TANK
- > PIPING ARRANGED FOR "POWER PURGING" AIR OUT OF SYSTEM PIPING, REFER TO THIS MANUAL'S SECTION ON "FILLING THE SYSTEM WITH WATER" OPTION #1

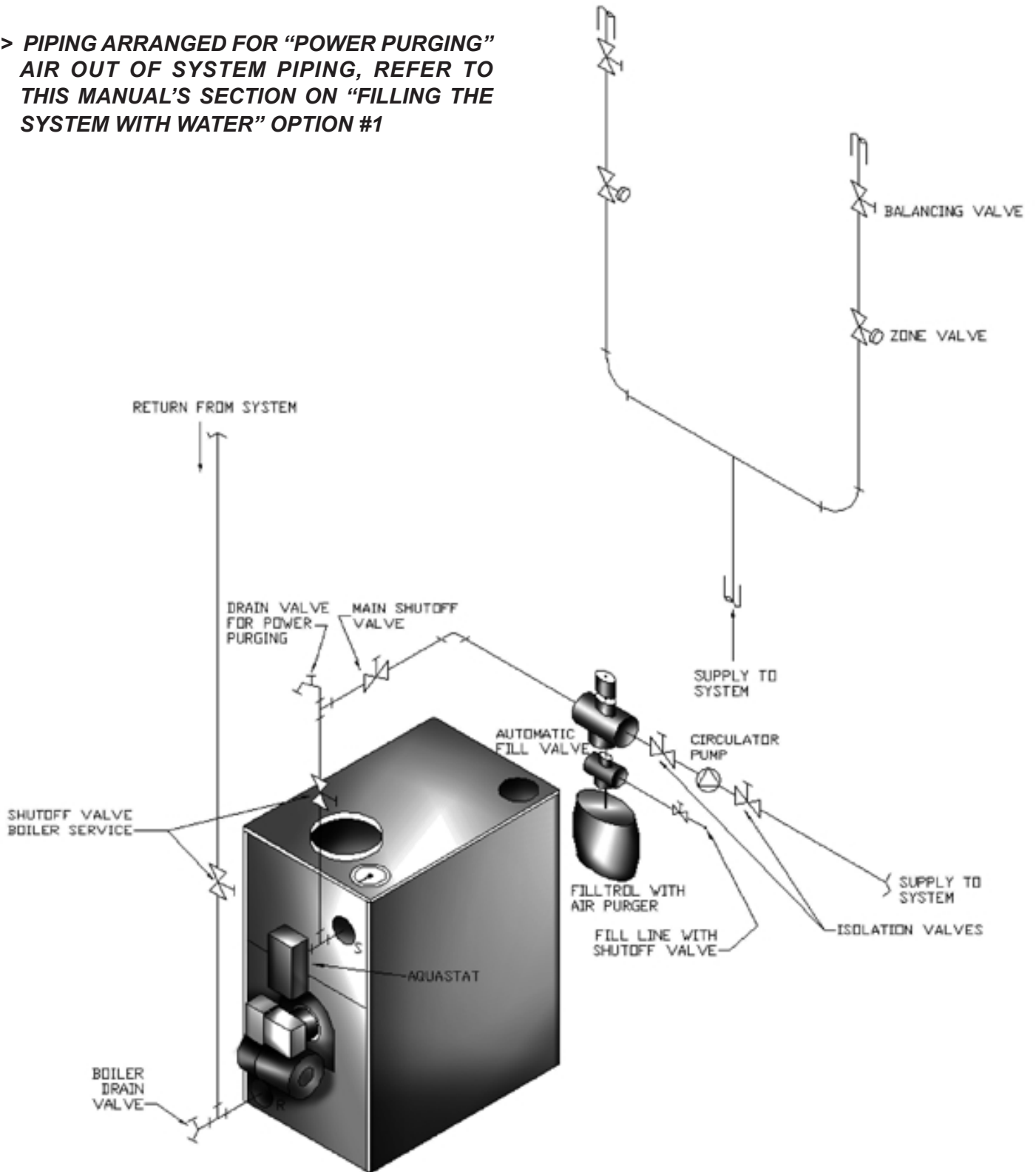

# SYSTEM PIPING ARRANGEMENT ZONING WITH CIRCULATORS

- > CIRCULATOR ON SUPPLY PIPING PUMPS AWAY FROM EXPANSION TANK
- > PIPING ARRANGED FOR "POWER PURGING" AIR OUT OF SYSTEM PIPING, REFER TO THIS MANUAL'S SECTION ON "FILLING THE SYSTEM WITH WATER" OPTION #1

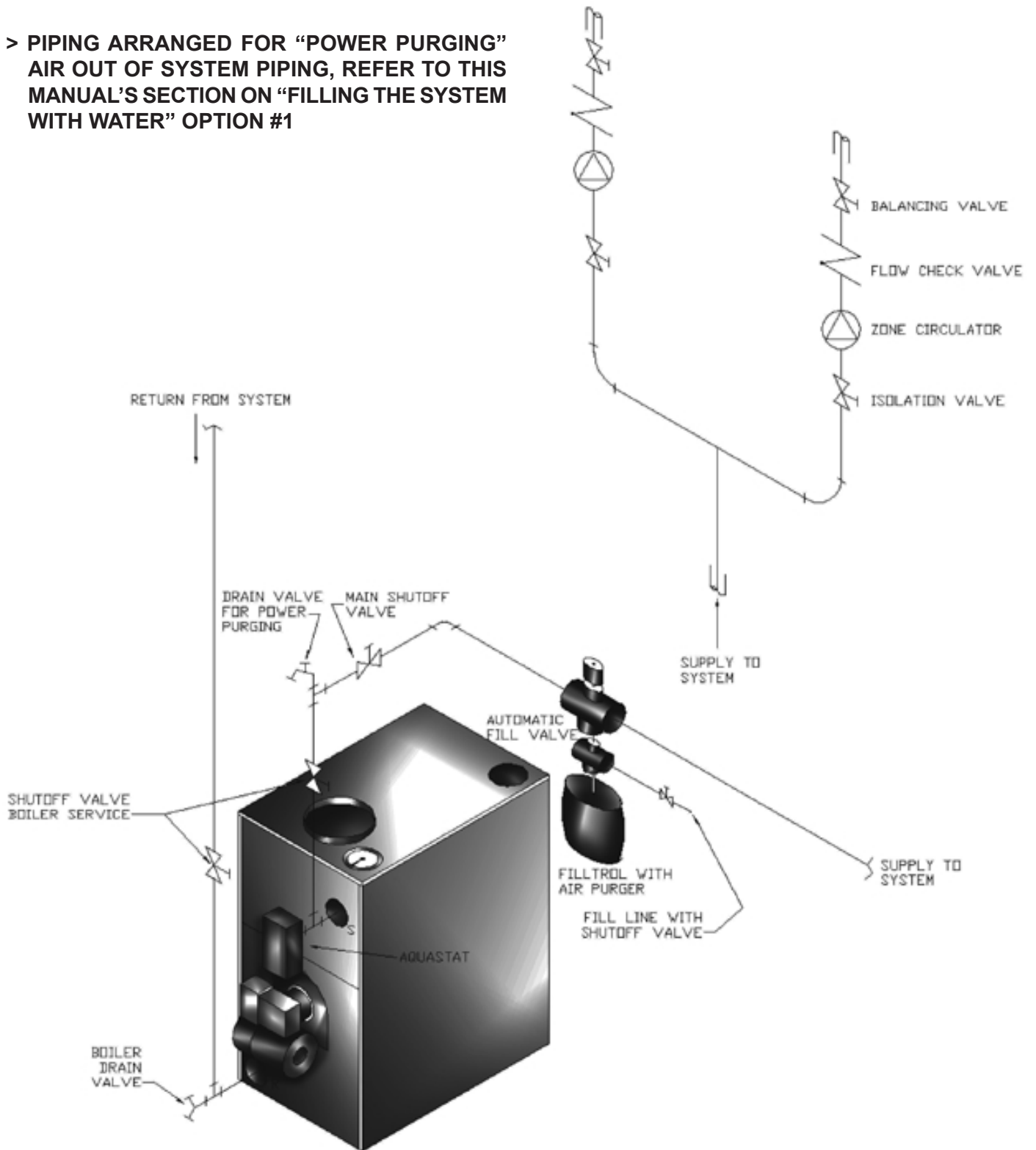

## SYSTEM PIPING ARRANGEMENT ALTERNATE NEAR BOILER PIPING

- > DIAPHRAGM EXPANSION TANK MOUNTED OFF THE BOILER
- > PER THIS MANUAL, USE OPTION #2 IN "FILLING THE SYSTEM WITH WATER"
- > CIRCULATOR ON SUPPLY PIPING PUMPS AWAY FROM EXPANSION TANK
- > THIS PIPING ARRANGEMENT CAN BE USED WITH ZONE VALVES OR ZONE CIRCULATORS

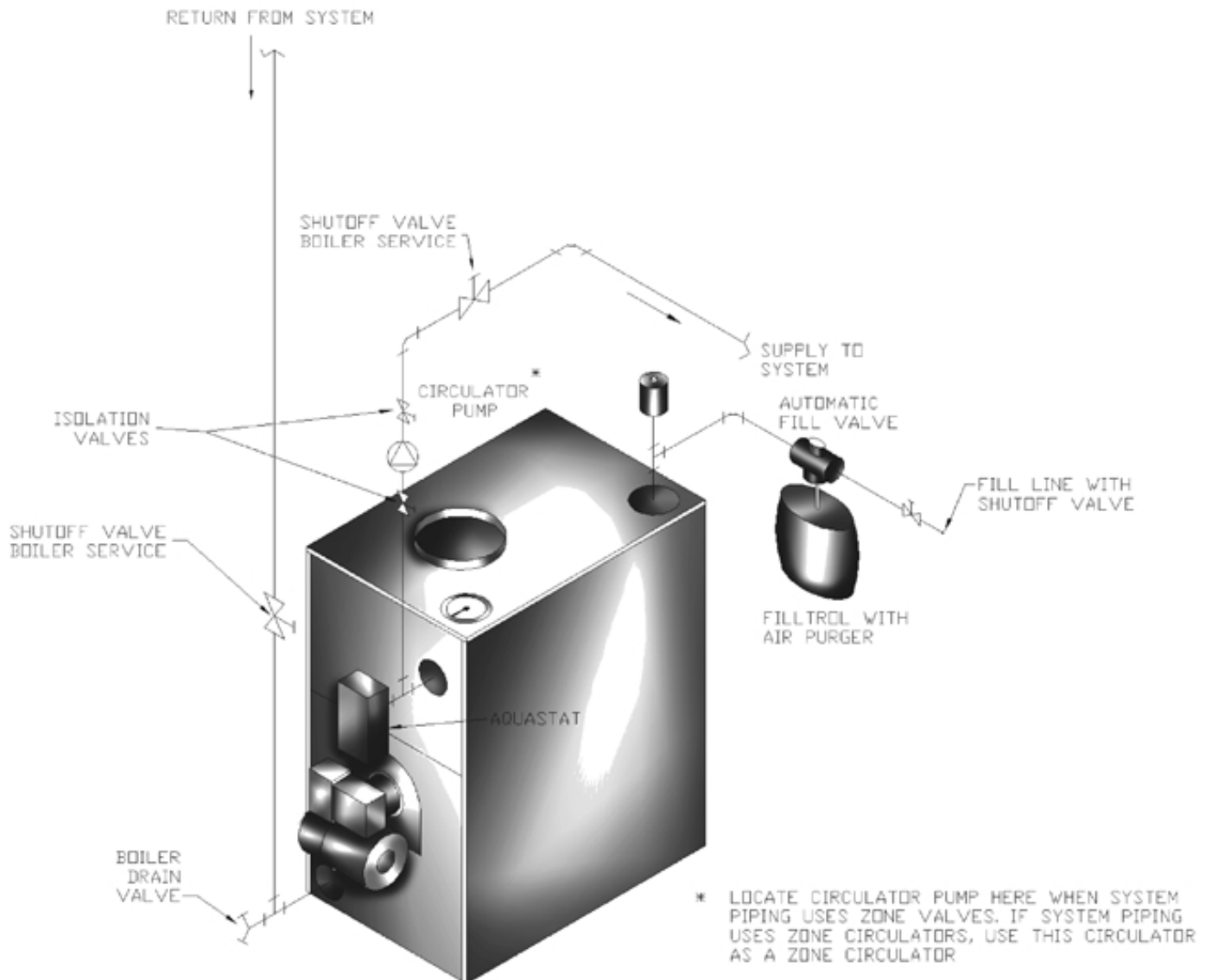

## SYSTEM PIPING ARRANGEMENT ALTERNATE NEAR BOILER PIPING

7. Boilers may be factory **packaged with a tankless heater coil** see figure below. This coil provides instantaneous heating of water for domestic use if proper burner and water supply line controls are used. Tankless coils are meant to provide domestic hot water for intermittent draws, not continuous flow.

**IMPORTANT!** Do not use a tankless coil if your water is excessively hard with lime or other deposits which will accumulate inside the coil.

When using a tankless coil, the boiler has been configured so the Honeywell L8124C Combination Hi/Low Limit Aquastat Relay mounts on a thermowell (provided) which needs to be installed in the  $\frac{3}{4}$ " tapping on the tankless coil. By mounting the aquastat on the coil, the tankless coil performance is maximized by making the burner

respond more quickly to a call for domestic hot water. A tempering valve (mixing valve) is also recommended as shown in figure below. A flow restrictor may be required on the tankless coil inlet piping so that flow rates are matched to boiler heat input (see table below).

Boiler Model	Burner Firing Rate (gph)	Input (MBH)	Tank less Rating (gpm)‡
3EW.65T	0.65	91	2.90
3EW.75T	0.75	105	3.00
3EW1.00T	1.00	140	3.25
4EW.90T	0.90	126	3.15
4EW1.25T	1.25	175	3.50
4EW1.50T	1.50	210	3.75
5EW1.20T	1.20	168	3.45
5EW1.75T	1.75	245	4.00
5EW2.00T	2.00	280	4.25

‡ Gallons of water per minute heated from 40°F to 140°F with 200°F boiler water temperature, intermittent draw

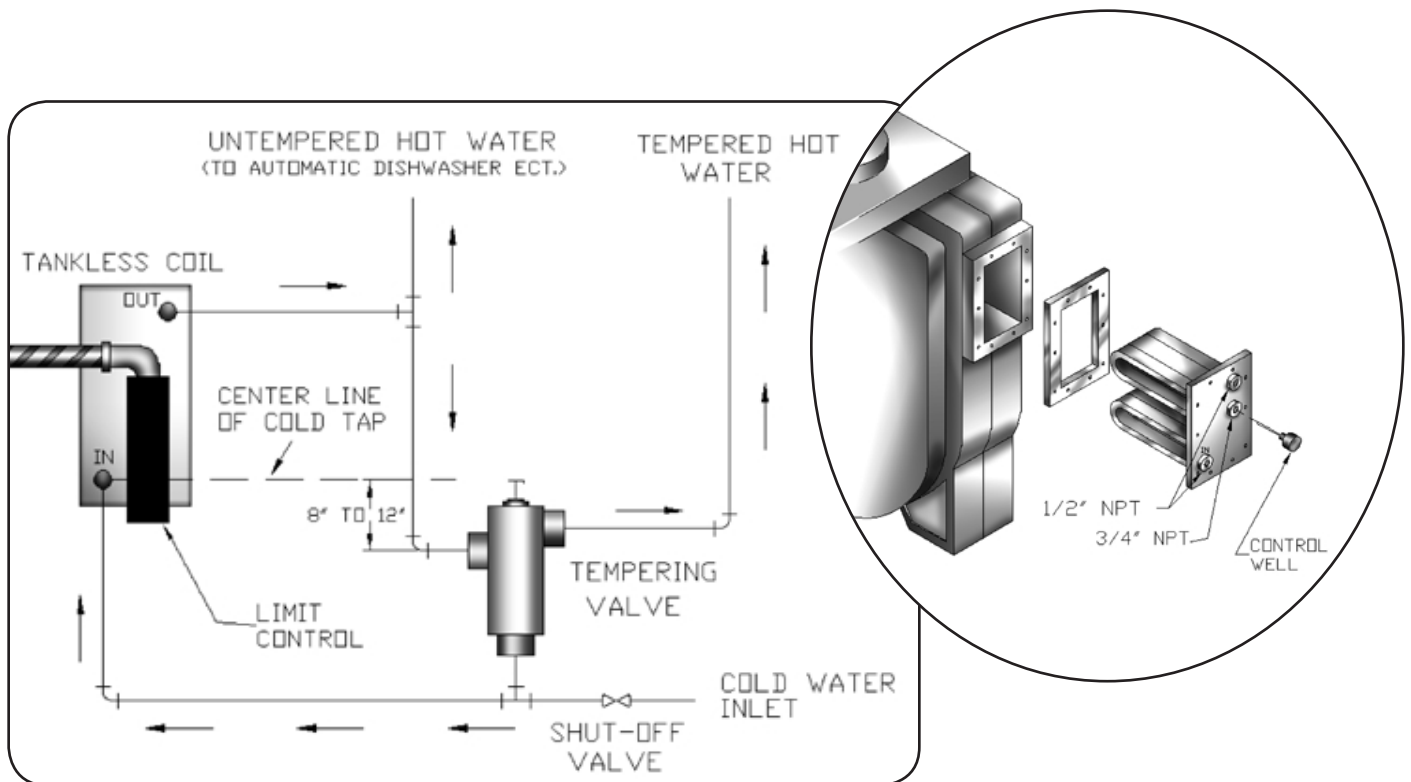

## SYSTEM PIPING ARRANGEMENT ALTERNATE NEAR BOILER PIPING

8. **Antifreeze added to boilers** must be nontoxic, and must be of a type specifically intended for use in closed hydronic heating systems. Under no circumstances should automotive antifreeze be used. Antifreeze used in any

boiler may reduce capacity by 10% or more and increase fuel consumption. Tankless coil performance will fall as concentration of antifreeze is increased. Refer to boiler and piping water volumes tables in this manual.

BOILER WATER VOLUMES	
Number of Boiler Section	Total Volume (Gallons)
3	9.6
4	11.6
5	13.7

PIPING WATER VOLUMES		
PIPE SIZE	COPPER PIPE FACTOR	STEEL PIPE FACTOR
1/2"	82.5	63.5
3/4"	40.0	36.0
1"	23.3	22.2
1 1/4"	15.3	12.8
1 1/2"	10.8	9.5
2"	6.2	5.8

Divide total length of piping in feet by appropriate factor in table to determine volume in gallons.



## CHIMNEY AND CHIMNEY CONNECTIONS

For oilfired boilers for connections to vents or chimneys, vent installations shall be in accordance with applicable provisions of INSTALLATION OF OIL BURNING EQUIPMENT, NFPA31 latest revision, and applicable provisions of local building codes.

This is a very important part of your heating system. No boiler, however efficient its design, can perform satisfactorily if the chimney that serves it is inadequate. Check your chimney to make certain that it is the right size, properly constructed and in sound condition.

It is cheaper to rebuild a poor chimney than to pay excessive fuel bills. If yours is an old chimney, a new steel liner or a new prefabricated chimney may be the best solution. The following chart shows recommended minimum chimney sizes based on Table 3 and Figure 6 of the **I=B=R Testing and Rating Standard for Heating Boilers**, Sixth Edition, June 1989.

RECOMMENDED MINIMUM CHIMNEY SIZES				
FIRING RATE (gph)	CHIMNEY HEIGHT (ft)	NOMINAL CHIMNEY	ROUND LINERINSIDE	SQUARE LINERINSIDE
0.60 1.30	15	8" x 8"	6"	6 3/4" x 6 3/4"
1.31 1.80	15	8" x 8"	7"	6 3/4" x 6 3/4"
1.81 2.00	20	8" x 8"	8"	6 3/4" x 6 3/4"

*For elevations above 2,000 feet above sea level, add 3 feet to the chimney heights.*

For additional chimney design and sizing information, consult the ASHRAE 1996 HVAC Systems and Applications Handbook, Chapter 30, Gas Vent and Fireplace Systems; or the National Standard for Chimneys, Fireplaces, Vents and Solid Fuel Burning Appliances, ANSI/NFPA 211.

### **CHIMNEY CONNECTOR AND DRAFT REGULATOR**

Venting the boiler requires a 6" diameter chimney connector pipe and using the draft regulator packed with the boiler. Properly installed, the regulator will control the draft automatically. It is better to install it in a horizontal section of pipe, but it may be installed in an angled or vertical section of pipe. Make certain that the "top" of the regulator is at the top and that the short pipe section which holds the vane is horizontal. Even though locating the draft regulator close to the chimney reduces noise, **install the draft regulator as close as practicable to the boiler.**

To install the chimney connector, start at the boiler with a vertical pipe and then elbow then install the draft regulator making it horizontal. When the regulator is in place, start at the chimney and work back to the regulator. Join the two sections with a drawband. The horizontal pipe must slope up toward the chimney at least 1/4 inch per linear foot of venting. The chimney connector must not leak and must be firmly supported. Join each of the sections with at least two sheetmetal screws. Support every second section with a stovepipe wire.

**Maintain a minimum vent pipe clearance of 18" from the surface of the vent to wood and other combustible materials.**

# TYPICAL CHIMNEY CONNECTION

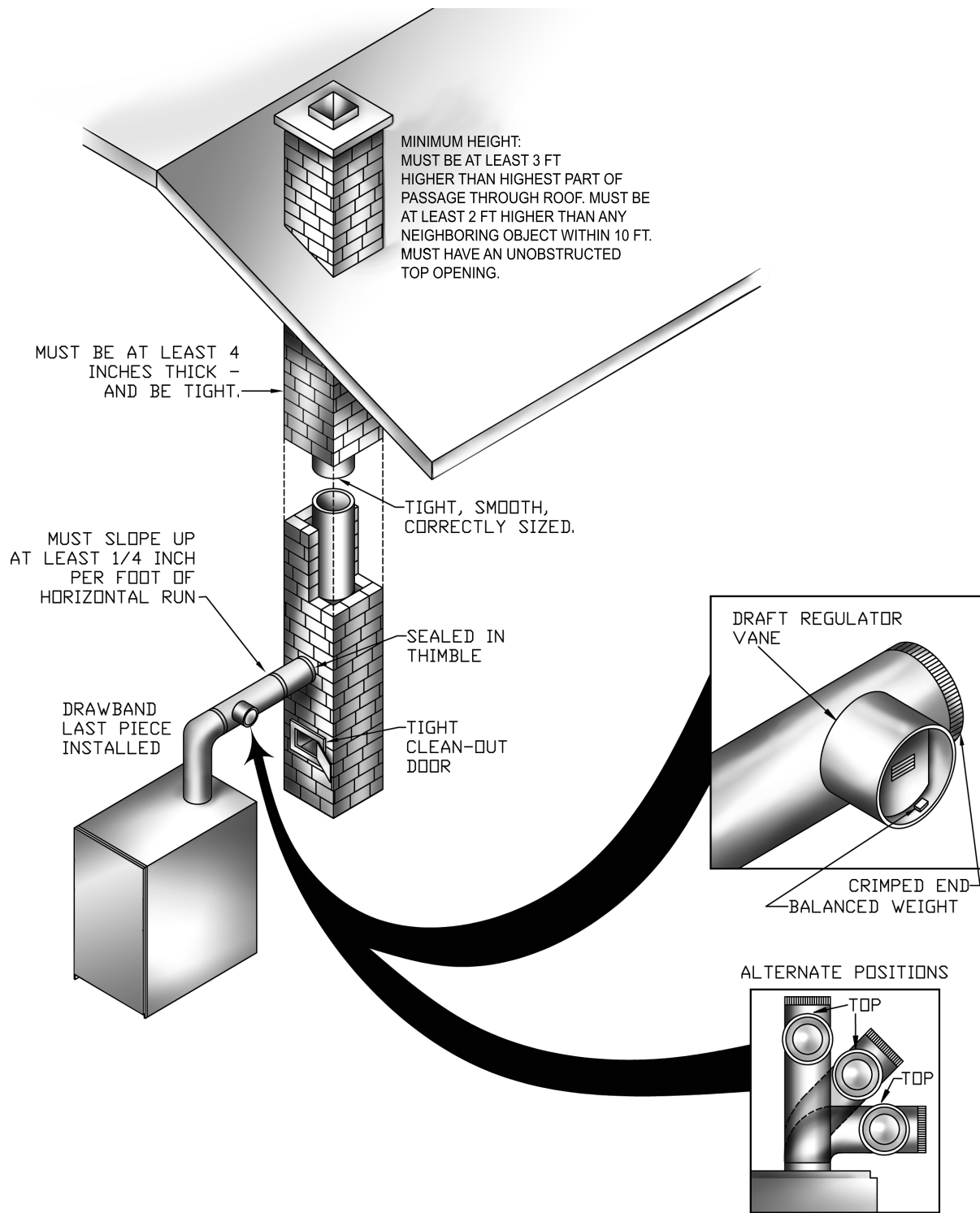

# ELECTRICAL CONNECTIONS

## THERMOSTAT

Install a 24-volt thermostat (not provided) in a proper location. The location of the thermostat has an important effect on boiler system operation. **BE SURE TO FOLLOW THE INSTRUCTIONS INCLUDED WITH THE THERMOSTAT.**

## GROUNDING

Permanently ground the boiler according to local codes and the National Electrical Code. Run a 14 gauge or heavier copper wire from the boiler to a grounded connection in the service panel or a properly driven and electrically grounded ground rod.

### **⚠ WARNING ⚠**

Turn off electric power at fuse box before making any line voltage connections. Follow local electrical codes.

## ELECTRIC POWER SUPPLY

All electrical work must conform to your local codes as well as the National Electrical Code. If you are not familiar with wiring and codes in general, have a competent electrician do this job.

On packaged boilers, the boiler controls are all wired at the factory. You need only connect a 115 volt electrical supply to the L1 and L2 terminals on the aquastat relay and two thermostat wires to the T and T terminals on the same aquastat relay (see figure below).

Run a separate circuit from a separate over-current protection device in your electrical service entrance panel. This should be a 15 ampere circuit. Locate a shutoff switch at the boiler. It must be turned off during any maintenance. Solder and tape or securely fasten these connections with wire nuts.

## OIL BURNER WIRING

For boilers packaged with oil burners, the burners are wired at the factory. For boilers shipped knockdown or packaged without a burner, wiring connections are shown in the electrical wiring diagrams of this manual.

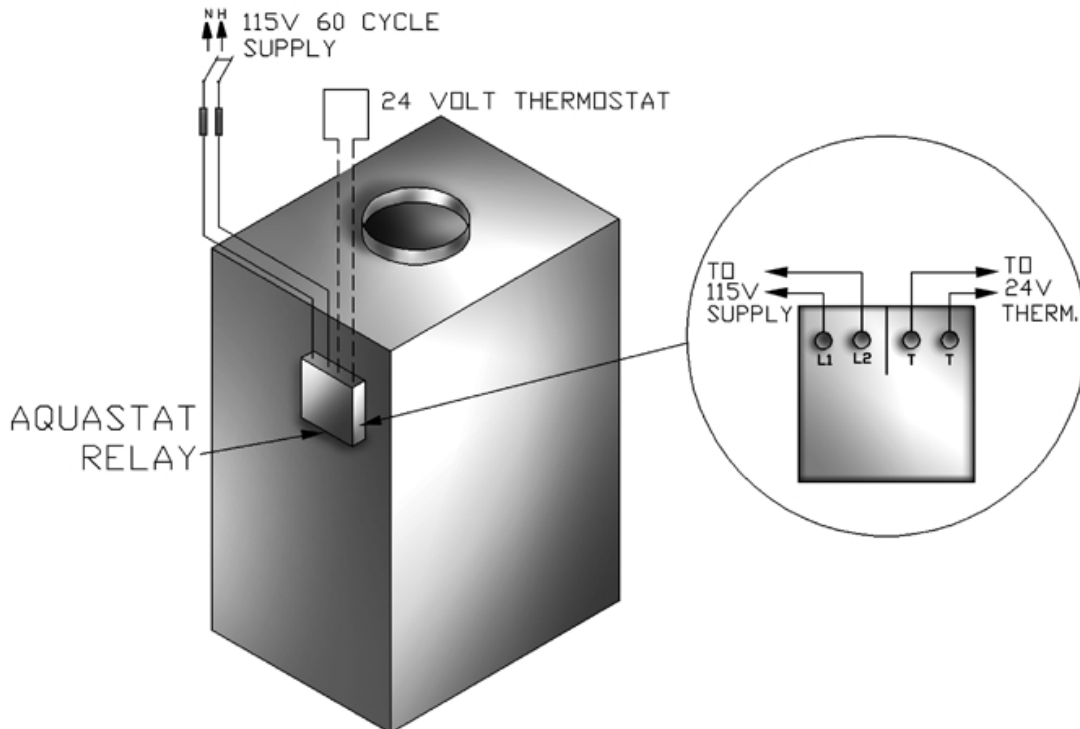

## EQUIPMENT AND OPTIONAL ACCESSORIES

### **RELIEF VALVE (provided)**

Each low pressure hot water heating boiler is provided with a relief valve for over pressure protection of the boiler and heating system. The relief valve will open when the pressure in the boiler rises to 30 psig. Each relief valve is provided with a lifting device for testing and should be tested monthly during the heating season. Discharge piping should be provided from the outlet side of the relief valve so as to prevent scalding or other hazardous situations. The discharge piping must remain full size and end at a safe point.

### **CONVENTIONAL EXPANSION TANK (not provided)**

In a properly assembled system, the expanding water flows into an expansion tank. The expansion tank should be sized correctly, because an improperly installed or sized expansion tank may result in frequent lifting of the relief valve or other heating system problems. It is important to install the tank higher than the boiler top and that the connecting pipe rise continuously up to the tank so air can bubble itself up through it.

An expansion tank is filled with air. The air compresses as water expands, thus forming an air pressure cushion. This “spring-like” cushion serves to maintain correct operating water pressure regardless of water temperature. This assures a “full measure” of water, even in the highest radiation unit of the system. The tank also serves as a trap for excess air in the system. The air can cause noises in the pipes and inefficient circulation in the radiators if left in the piping system.

It is possible for a tank to become “waterlogged” (filled with water). It can also become overfilled with air when filling the system with new water. Fittings provided on the tank and in the line to the tank are for bleeding off excess air and water.

### **DIAPHRAGM EXPANSION TANK (not provided)**

The diaphragm type expansion tank takes the place of the conventional expansion tank. Carefully read the instructions packed with your tank assembly. The expansion tank should be sized and installed correctly, because an improperly installed or sized expansion tank may result in frequent lifting of the relief valve or other heating system problems.

The tank typically comes with a 10-12 psig air charge. This is the same as the pressure produced in the system by an automatic fill valve set to fill the boiler to 10-12 psig with fresh water. When the system is first filled, the tank will contain little or no water. As the water is heated, and system pressure increases, the water expands into the tank and compresses the air in the tank. This compressed air cushion permits the water in the system to expand as the temperature changes and assures a “full measure” of water, even in the highest radiation unit of the system.

The diaphragm type expansion tank can be mounted on the air purger fitting or at any other convenient place in the supply or return line. It is recommended to locate the diaphragm type expansion tank (a) in the supply line with the circulator located after the expansion tank or (b) off the  $\frac{3}{4}$ " tapping provided on the top of the rear casting with the circulator mounted directly off the boiler's supply piping connection. This configuration allows the circulator to “pump away” from the expansion tank for improved air elimination and system performance. The air eliminator fitting or air purger is not provided. The air eliminator fitting or air purger is used to help remove air from the system before it reaches the radiators. It should be installed in the supply line. Air left in the system can cause noises in the pipes and inefficient circulation in the radiators.

## EQUIPMENT AND OPTIONAL ACCESSORIES

### **MAIN AIR VENT: for down flow systems or diaphragm type expansion tanks (not provided)**

Before a system is filled with water, there is air in the pipes and radiation units. Some of the air will be trapped as the system is filled. It is possible to eliminate most of this air through the air vents on the radiation units. A main air vent will speed and simplify this process. The main air vent should be installed on the highest point in the supply main when all radiation is below the top of the boiler.

### **AUTOMATIC FILL VALVE (not provided)**

For safe, efficient operation, a hot water system must be filled with water. Adding new water, when needed can be done manually (by use of a hand valve in the water supply line). This requires regular attention to the system's needs. An automatic fill valve or pressure reducing valve accomplishes this without attention. It is installed in the supply line on hot water boilers only. The valve operates through water pressure differentials. It does not require an electrical connection.

### **BURNER SOLENOID VALVE (provided)**

The Beckett and Carlin oil burner's use a standard solenoid valve. Upon burner shut down, a standard solenoid valve stops the flow of oil to the nozzle. Without the solenoid valve, the oil pump continues to pump oil to the burner nozzle until the burner motor winds down below the pumps cutoff speed. The Riello oil burner has a delay solenoid valve. The delay solenoid valve provides the same shut down action as the standard solenoid valve, plus on burner start up the delay solenoid valve remains closed for an additional 15 seconds. This allows the burner fan motor to prepurge the combustion chamber and the oil pump to bring the supply oil pressure up to its set point helping to provide a clean light off.

### **AQUASTAT RELAY CONTROL (provided)**

The water temperature limit control in the aquastat relay is adjustable and may be set: as low as 140°F so long as return water temperatures to the boiler are no less than 120°F, or as high as 240°F so long as the boiler and heating system have adequate circulation to remove the heat from the boiler otherwise steam may be created in the boiler. Refer back to **SYSTEM PIPING** section for more information.

### **DRAIN VALVE (provided)**

The drain valve is a manually operated valve that provides a means of draining all the water from the boiler and heating system. It should be installed in the reducing tee where the return line enters the boiler.

### **CIRCULATOR (provided)**

Every forced hot water system requires a circulator. A separate circulator or zone valve is required for each zone, if there are two or more zones. The circulator must have the capacity to provide the circulation required by the heating system. The circulator should be connected to the supply main and must be wired into the boiler's electrical system. See the **SYSTEM PIPING** section for piping configurations with the circulator located on the supply main piping using zone circulators or zone valves. When the piping is arranged with zone circulators and no bypass piping, the circulator provided with the boiler may be used as a zone circulator. Both piping arrangements allow the circulator to pump away from the expansion tank and show how the piping should be arranged to allow the heating system to be easily purged of air.

The pump curve for the furnished Taco 007 pump is shown below

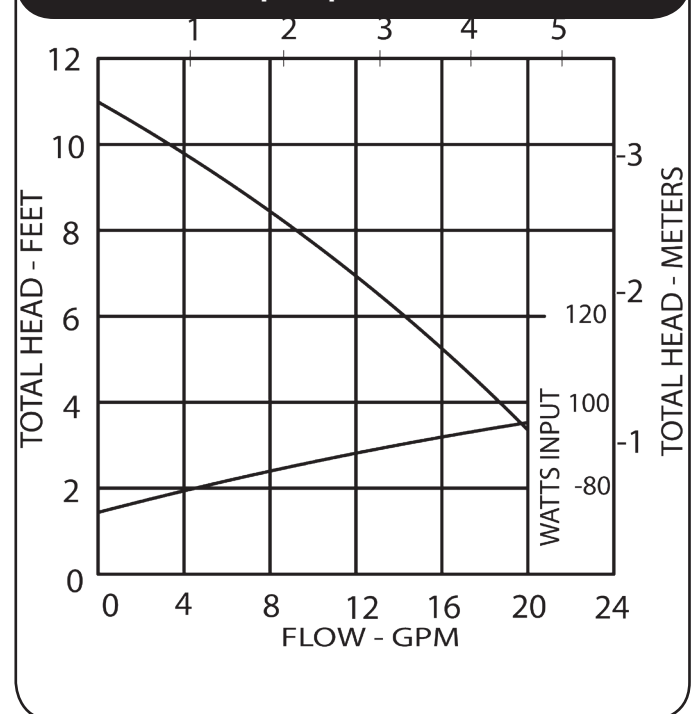



## FILLING THE BOILER

### HOW A HOT WATER SYSTEM OPERATES

The entire heating system (boiler, piping, and radiation units) is filled with water. As the water in the boiler is heated, it is circulated from the top of the boiler through the supply main to the radiation units. The cooler water in the radiation units flows back through the return piping through the return main into the boiler. This arrangement provides positive and rapid response to the thermostat.

### FILLING THE SYSTEM WITH WATER

**OPTION #1** This method utilizes the boiler piping as shown in the figure on the previous page.

- a) **Close** the main shutoff valve, isolation valves, and zone valves (if applicable). If bypass piping is installed, also close the two throttling valves. Leave the boiler service shutoff valve (if installed) and the balancing valves to each heating zone **fully open**.
- b) **Open** the following valves in order: the drain valve for power purging, isolating valves before and after the boiler circulator (if applicable), both throttling valves (if applicable), and then open the fill line shutoff valve. Water will fill the bypass piping and push the air through the piping and out the power purging drain valve. When the power purging drain valve runs air free, close the bypass piping throttling valve (leaving the throttling valve to the supply piping fully open).
- c) Next, **open** the isolation valve (or zone valve) to the first zone. Water will fill the piping and push any air out the power purging drain valve. When the power purging drain valve runs air free, close the isolation valve or zone valve). Repeat this procedure for the remaining heating zones.

- d) Once all zones are filled with water and purged of air, **close** the power purging drain valve and fill line shut off valve, **open** the main shutoff valve, and **adjust** the throttling valves and balancing valves as required.

**OPTION #2** Close the air vents on all radiation units. Open the valves to the radiation units. Make sure the boiler drain valve, expansion tank drain cock, and the air bleed screw on the expansion tank drain fitting are closed. Open the fill valve on the piping to the expansion tank. Open the water inlet to the boiler and leave it open. Open the air vent on the lowest radiation unit. When all the air has escaped and water starts to flow from the vent, close it. Go to the next radiation unit, and repeat this process until finishing with the highest radiation unit. If the heating system has automatic vents, this manual venting is unnecessary but it will speed up the proper filling of the system.

If the system is a closed expansion tank system, an automatic fill valve is needed. Leave the automatic fill valve open to refill the system automatically as needed. Note the initial fill pressure on the boiler's temperature / pressure gauge, which should be 10-15 psig. Any lowering of the pressure from its initial fill pressure indicates a loss of water due to leakage. The automatic fill valve should then compensate for this water pressure loss. If it does not, manually open this valve to refill the system until the needle is again pointing to the same pressure reading. Instructions are packaged with the valve.



## OPERATING THE BOILER

**DO NOT TAMPER WITH THE UNIT OR CONTROLS**

**IMPORTANT** *You or your installer must follow these instructions carefully.*

**STARTING:** Fill the entire system with water. Vent all air from the system following the section for **FILLING THE BOILER**.

**FUEL UNITS AND OIL LINES:** Install oil line(s) to the oil burner. Recommend using heavy wall copper tubing and flared fittings, not compression fittings. All connections and joints must be absolutely airtight. Use an appropriate nonhardening thread sealing compound on the threaded connections, not Teflon tape. See fuel unit data sheet furnished with the burner for sizing, lift, and length of tubing recommendations.

The original equipment oil burner (when furnished) is equipped with a single stage fuel unit with the bypass plug removed for single pipe installation. This is satisfactory where the fuel supply is on the same level as, or above the burner, permitting gravity flow of oil. Per NFPA31 requirements, never exceed 3 psig pressure to the inlet side of the fuel unit. When it is necessary to lift the oil to the burner, a two pipe installation is required. Run a return line between the fuel unit and the oil supply. When a two pipe installation is used, the bypass plug (furnished with the burner) must be installed in the fuel unit. Refer to the fuel unit instructions furnished with the burner for specific instructions on installing the bypass plug. Do not exceed the fuel unit manufacturer's recommendations for running vacuum.

**NOTE:** *If lift exceeds 14 feet for Beckett or Carlin burners or 11 feet for Riello burners, a twostage fuel unit is required with a return line.*

Install an oil filter of adequate size inside the building between tank shutoff valve and the oil burner. For ease of servicing, locate the shutoff valve and filter near the oil burner.

**AIR SUPPLY FOR COMBUSTION:** Do not install the boiler in rooms with insufficient air, unless corrective steps are taken. Occasionally, it is necessary to install windows or cut holes in a door to rooms used for supply air to obtain sufficient combustion air and prevent less than atmospheric air pressure in that room. If there is a lack of combustion air, the burner flame will be dark orange and the formation of soot will occur in the heating unit. In buildings of conventional frame, brick, or stone construction that do not have utility rooms, basement windows, or stair doors, air infiltration is normally adequate to provide enough air for combustion and for operation of the barometric draft control. The room used for supplying combustion air should be isolated from any area served by exhaust fans. Refer back to the section on **FRESH AIR FOR COMBUSTION** for additional sizing guidelines.

**DRAFT REGULATORS:** A barometric draft regulator is required for controlling the draft through the boiler. The barometric draft regulator is mounted in the chimney connector. Refer back to the section on **CHIMNEY AND CHIMNEY CONNECTIONS**. Once the draft regulator is installed, use a draft gauge to adjust to the proper opening: combustion chamber over fire draft will be approximately a 0.01" WC to 0.02" WC and the stack draft will be approximately 0.02" WC. to 0.04" WC. On a larger installation, a greater draft will be required in the stack to obtain the desired over fire draft.

## OPERATING THE BOILER

**NOZZLES AND ELECTRODES:** Use the proper size, spray angle, and spray pattern nozzle. Refer to the recommended nozzle selection charts at the end of this manual. To install a nozzle, remove the nozzle line electrode assembly, if necessary remove the retention ring assembly, and then install and tighten the nozzle. Be careful not to damage the electrode insulators or the bend the electrode tips. After installing the nozzle, reassemble the nozzle line electrode assembly and set the electrode tip spacing. Depending on the burner purchased, the electrode tip spacing may need to be set prior to reassembling the nozzle line electrode assembly. Refer to the figures on the following pages for setting the electrode tip spacing on Beckett, Carlin, and Riello burners.

**FINAL BURNER ADJUSTMENTS:** Final burner adjustments must be made using combustion test instruments. Initial settings for the burner are shown at the back of this manual.

Set the burner accordingly. Check the draft over fire to verify that it is between 0.01" WC and 0.02" WC, otherwise adjust the draft as necessary. After operating 10 minutes to warm up the boiler, use the combustion test equipment to take a smoke reading in the flue pipe between the boiler and the draft regulator. The smoke reading should be zero to a trace (Shell Bacharach Scale). At times a new boiler requires more than 10 minutes to burn clean due to the oil film on the new heat exchanger. If the smoke reading is zero, gradually close the burner's air adjustment to obtain a smoke reading showing a trace smoke reading. Once the smoke reading is a trace, measure the CO<sub>2</sub> and as an insurance margin increase the air to sufficiently reduce the CO<sub>2</sub> by 1/2% to 1%.

If a clean fire cannot be obtained, it will be necessary to verify the burner head and electrode alignment. Proper electrode alignment figures are presented on the following pages. If the fire continues to be smoky, replace the nozzle with a correct replacement. Once the burner is completely adjusted, the

burner should be started and stopped several times to assure good operation with no fluttering or rumbling. Verify that there are no oil leaks and then record the nozzle size, oil pressure, combustion readings, and air settings on a tag or label that can be attached to the burner or, boiler.

**OIL BURNER MAINTENANCE:** For the Beckett AFG, Carlin EZ1 or EZ2, and the Riello 40 F3, F5, or F10 the following preventative maintenance items should be performed annually, preferably prior to the heating season.

1. **Oil Burner Motor** For Beckett and Carlin burners, add 2-3 drops of non-detergent electric motor oil to each oil cup located at the front and rear of the motor (Riello burners are permanently lubricated). Excessive oiling will shorten the life expectancy of the motor.
2. **Fuel Filter** This should be replaced so as to prevent contaminated fuel from reaching the nozzle. A partially blocked fuel filter can cause premature failure of the fuel pump.
3. **Fuel Pump Unit** Replace pump screen and clean pump unit to maintain fuel delivery to the nozzle.
4. **Ignition Electrodes** Clean and adjust as per manufacturer's recommendations, so as to maintain reliable ignition of oil.
5. **Nozzle** Replace so as to maintain safe and reliable combustion efficiency. Always replace with the exact nozzle as required in the charts in the back of this manual.
6. **Fan and Blower Housing** These must be kept clean, free of dirt, lint and oil so as to maintain the proper amount of air the fuel requires to burn.
7. **Check the final burner adjustments.**

**NOTE:** *If any component parts must be replaced, always use parts recommended by the burner manufacturer.*

# OPERATING THE BOILER

## BECKETT AFG BURNER ELECTRODE ADJUSTMENTS VARIABLE (V1) HEADS

BOILER MODEL	DIMENSION "N" (electrode to nozzle)	DIMENSION "H" (head to nozzle)
SEW	1/16"	7/32" - 9/32"

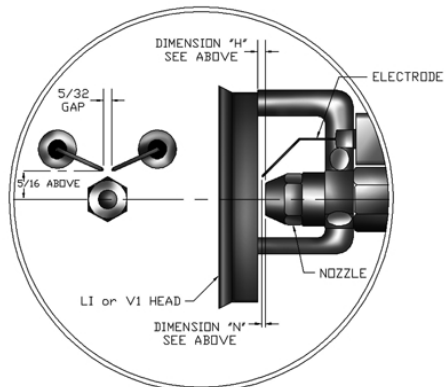

## BECKETT AFG VARIABLE (V1) HEAD ADJUSTMENTS AND SETTINGS

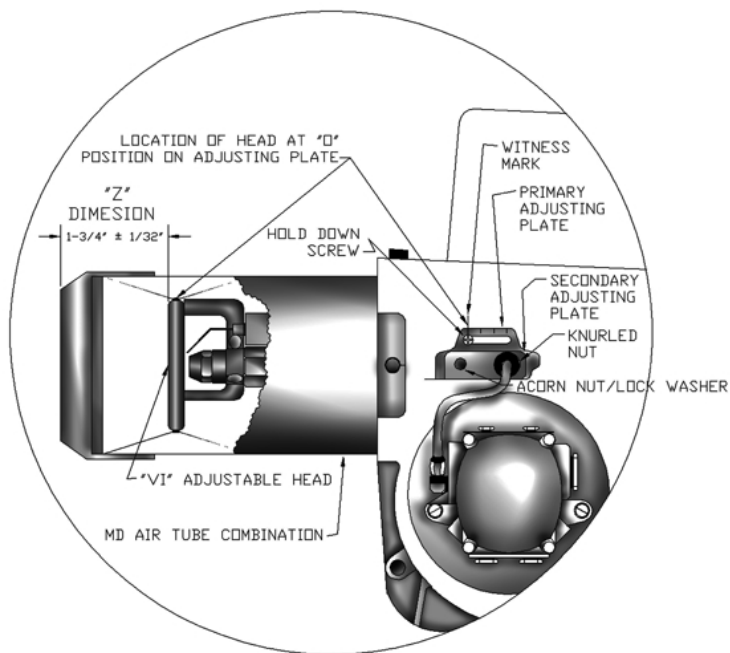

## BECKETT AFG BURNER ELECTRODE ADJUSTMENTS F-HEADS

BURNER F-HEAD MODEL	DIMENSION "N" (HEAD TO NOZZLE)
F0 THRU F31	1/16"

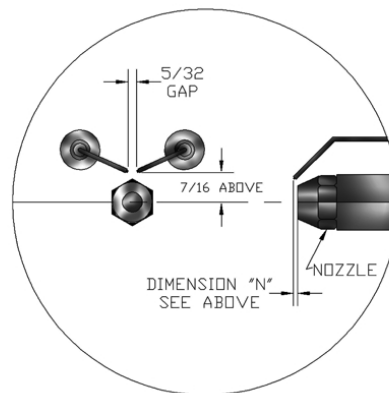

## CHECKING AND ADJUSTING CONTROLS

A boiler using a tankless coil is configured with a Honeywell L8124C Combination Hi/Low Limit Aquastat Relay (refer back to the SYSTEM PIPING section for more details). A boiler not using a tankless coil is configured with a Honeywell L8148A Hi Limit Aquastat Relay. Instructions for the control provided are included with the boiler.

**IMPORTANT:** *You or your installer must follow these instructions carefully.*

**ADJUST OPERATING CONTROLS:** For both aquastats, use the following settings for the first adjustment:

**High Limit:**

Baseboard and Convectors 200°F  
Standing Radiators 180°F

**Low Limit** (when used) 140° (increase if hotter domestic water is required, but low limit set point must be at least 20°F less than the high limit set point)

**Differential** (when used) 10°F

**ADJUST THERMOSTAT HEAT ANTICIPATOR TO: 0.2 AMPS**

**Do not attempt to start the burner when excess oil has accumulated, when the unit is full of vapor, or when the combustion chamber is very hot.**

**CHECK THERMOSTAT OPERATION:** The thermostat location has an important effect on the operation of the boiler system. Be sure to **FOLLOW THE INSTRUCTIONS** included with your thermostat. Typically the thermostat is located about five feet above the floor on an inside wall. The thermostat should be located to sense average room temperature, so avoid the following:

THERMOSTAT LOCATIONS TO AVOID		
DEAD SPOTS	HOT SPOTS	COLD SPOTS
Behind doors	Concealed pipes	Concealed pipes or ducts
	Fireplace	
	TV sets	Stairwells drafts
Corners & alcoves	Radios	Doors drafts
	Lamps	Unheated room on other side of wall
	Direct sunlight	
	Kitchens	

When the temperature on the thermostat is set above the indicated thermostat temperature, the boiler's burner should start. Make certain: once the room temperature reaches the selected temperature setting, the thermostat should turn the boiler's burner off, and once the room temperature falls a few degrees the boiler starts operating again. **Do not start the burner unless all cleanout doors are secured in place.**

## MAINTENANCE

**ANNUALLY:** To assure trouble free operation, it is recommended that the flue passages, combustion chamber area (target wall, fire door insulation, durablanket), burner adjustment, operation of the controls, and boiler seals (fire door gasket or silicone seal, cast iron sectional seals, flue collector) be checked once each year by a competent Service Technician. **Before the start of each heating season** (or whenever the system has been shut down for extended periods of time) recheck the whole system for water, oil, and vent piping leaks. Replace or patch any leaks or seals that are faulty.

**VENT PIPE:** Visually inspect the entire venting system once a month for any signs of leakage, deterioration, or soot build up. If the vent pipe shows any signs of leaking or deterioration, replace it immediately. If it shows any signs of soot build up, clean the vent pipe and have the burner settings and combustion checked by a competent professional.

**RELIEF VALVE:** This valve should open automatically when the system pressure exceeds the pressure rating (usually 30 psi) of the relief valve. Should the valve ever fail to open under this condition, shut down the system. Drain the system until system pressure is reduced below the relief valve pressure rating. Then contact a competent Service Technician to replace the valve and inspect the heating system and determine the cause, as this problem may indicate an equipment malfunction. The relief valve should be tested monthly during the heating season. Prior to testing, make certain a discharge pipe is properly connected to the valve outlet and arranged so as to contain and safely dispose of boiler discharge. Hold the trip lever fully open for at least five seconds in order to flush free any sediment that may lodge on the valve seat. Then permit the valve to snap shut. Refer to the valve manufacturer's instructions packaged with the valve for more details.

**CONVENTIONAL EXPANSION TANK:** As noted in the **EQUIPMENT AND OPTIONAL ACCESSORIES** section, this tank may become water logged or may receive an excess of air. Frequent automatic opening of the relief valve indicates water logging. A high boiler temperature accompanied by unusually low radiation unit temperature (and "knocking" noises) indicates excess air in the tank. To correct either condition, close the valve between the boiler and the tank. Drain the tank until empty. Check all the tank plugs and fittings, tighten as necessary. Open the valve between the boiler and tank. Water will rise to the normal height in the tank if the system has an automatic fill valve, otherwise manually refill the system.

**DIAPHRAGM EXPANSION TANK:** As noted in the **EQUIPMENT AND OPTIONAL ACCESSORIES** section, this tank may become water logged. Frequent automatic opening of the relief valve indicates water logging. A high boiler temperature accompanied by unusually low radiation unit temperature (and "knocking" noises) indicates excess air in the tank. To correct this condition, replace the diaphragm expansion tank.

**WATER SYSTEM:** If the system is to remain out of service during freezing weather, always drain it completely (water left in to freeze will crack the pipes and/or boiler).

**TANKLESS COIL (OR COVER PLATE) GASKET:** This gasket should be checked at least twice a year for leakage and replaced if necessary. If the gasket is replaced, make sure that when the coil plate (or cover plate) is reattached that the ten nuts are torqued in an alternating pattern to ensure equal force is applied to the entire gasket creating a good seal. The nuts should be torqued such that the gasket does not squeeze out from behind the plate.

**OIL BURNER:** Oil burner maintenance is listed in this manual under **OPERATING THE BOILER**.

**Never burn garbage or paper in the unit, and never leave combustible material around it.**



## OIL BOILER / BURNER CLEANING INSTRUCTIONS

### OIL BOILER CLEANING:

1. Shut off all electrical power to the boiler / burner and shut off fuel oil supply.
2. Remove the vent pipe from the top of the boiler. Inspect the pipe and chimney for signs of corrosion and deterioration. Clean out the base of the chimney. If the vent pipe shows any signs of corrosion or deterioration, replace it immediately. If chimney damage or deterioration is discovered, contact a competent professional.
3. Remove the top jacket panel screws (5), the brass wing nuts (2) holding the flue collector top, and then the flue collector top. Inspect the gasket on the underside of the flue collector and replace as necessary.
4. Before beginning to clean the flue passageways, ensure that the combustion chamber blanket is covered. If the blanket is not covered prior to cleaning, replace the blanket once cleaning is completed.
5. Now with access to the flue passageways, remove the soot from the fireside surfaces by brushing diagonally through the flue passages (see drawing below). Brushing can be made easier by cutting the end of the flue brush off and inserting it into a drill. When brushing, care should be taken so as not to damage the target wall with the flue brush.
6. Carefully vacuum the soot accumulations from the combustion chamber area, being particularly careful to not damage any of the refractory or blanket insulation. To gain access

to the combustion chamber first double check that the shut off valve on the fuel oil line is closed and then disconnect the fuel oil line. Then open the swing door by simply removing the whiz lock nut holding the door shut.

7. Now inspect the target wall, fire door refractory, and combustion chamber blanket (when included) for cracking and deterioration. If there is any signs of cracking or deterioration, replace the refractory or blanket before reassembling the burner / front plate.

8. Inspect the door's braided gasket for wear and damage. Replace when necessary with braided gasket of the same material and size. See repairs parts section of this manual.
9. Now inspect and clean the oil burner.

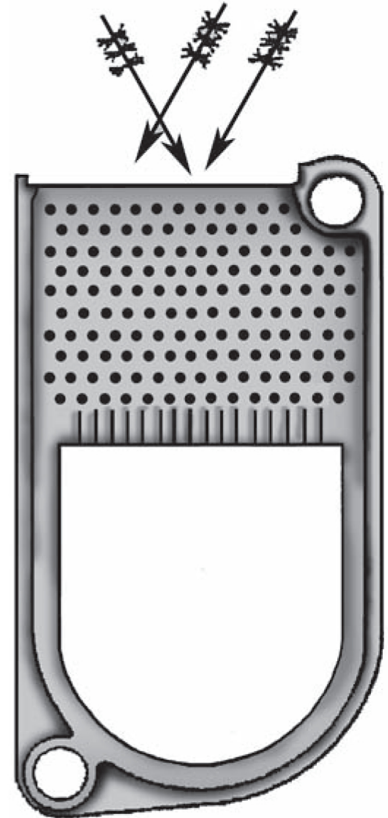

### **IMPORTANT OPERATING AND MAINTENANCE REQUIREMENTS:**

- **KEEP YOUR BOILER AND THE AREA AROUND IT CLEAN**
- **NEVER BURN REFUSE OR ANY MATERIAL OTHER THAN THE SPECIFIED FUEL IN YOUR BOILER**
- **HAVE YOUR BOILER CHECKED EACH YEAR BY A QUALIFIED TECHNICIAN**



## OIL BURNER CLEANING

These are general instructions for cleaning an oil burner. For specifics, consult the burner manufacturer's instructions.

1. Make sure all electrical power to the boiler / burner and the fuel supply to the burner are shut off.
2. With the swing door open, clean any soot accumulations from the end of the burner and if applicable burner head.
3. Remove the burner drawer assembly, clean the electrodes and then reset the electrode spark gap per the manufacturer's recommendations. Refer back to the section in this manual on **OPERATING THE BOILER** Nozzles and Electrodes.
4. Replace the oil nozzle with the exact same size and type recommended for use on this boiler.
5. Reinstall the burner drawer assembly making sure the head location (*and size if applicable*) are per the manufacturer's recommendations. If the burner being used has a damaged head, replace the head with the exact same head recommended for use on this boiler.
6. Inspect and clean the oil burner blower wheel.
7. Remove the oil pump cover and clean / replace the pump screen. Carefully reassemble ensuring the pump cover makes a proper seal.
8. Securely fasten the swing door shut.
9. Replace the fuel filter (*if applicable*).
10. Reconnect the electrical and fuel supplies.
11. Fire the burner, checking for proper combustion using combustion test equipment and making adjustments as necessary. Refer to the section in this manual on **OPERATING THE BOILER** Final Burner Adjustments.
12. Insure that all safety controls and operating controls are functioning properly.

## SERVICE HINTS

*You may avoid inconvenience and service calls by checking these points before you call for service:*

### FOR YOUR SAFETY

#### WHAT TO DO IF YOU SMELL GAS

1. Do Not try to light any appliance.
2. Do not touch any electric switch, do not use the phone.
3. Leave the building immediately, then call your gas supplier.
4. If you cannot reach the gas supplier, call the fire department.

### IF YOUR SYSTEM IS NOT HEATING OR NOT GIVING ENOUGH HEAT . . .

<i>POSSIBLE CAUSE</i>	<i>WHAT TO DO</i>
Thermostat is not set correctly	Reset thermostat
Burner is not operating properly	Check flame. If it is yellow, the burner is not getting enough air. Or, if flame is blue and noisy and seems to lift off the burner, the burner is getting too much air. Contact your service technician.
No electric power to boiler	Check overcurrent protection. Check to be sure electric power supply circuit is "ON".
Controls out of adjustment	Reset according to instructions.
Radiators not heating	Open radiator vents to excess air. Check flow control valve (if used). It may be in closed position.
Circulating pump not running	Check overcurrent protection. Check relay operation.
Poor electrical contact	Check all control terminals and wire joints.
Chimney flue is blocked	Pressure switch will not close and pilot spark will not operate to start pilot. Have your service technician check and correct, if necessary.
Rollout switch blown	Have your service technician check heat exchanged for blockage. Replace rollout switch with exact replacement.

### IF BURNER IS NOISY . . .

<i>POSSIBLE CAUSE</i>	<i>WHAT TO DO</i>
Gas input amount is incorrect	Contact your service technician.

### RELIEF VAVLE LEAKING . . .

<i>POSSIBLE CAUSE</i>	<i>WHAT TO DO</i>
Dirt on seat	Open valve manually. Allow water to run and clear valve seat.
Water logged expansion tank	Drain tank, see instructions.

**HAVE YOUR SERVICE TECHNICIAN CHECK ANY PROBLEM YOU ARE UNABLE TO CORRECT.**

# ELECTRICAL WIRING

**BOILER WITH TANKLESS COIL AND AND HONEYWELL L8124C AQUASTAT CONTROL (BECKETT AFG BURNER SHOWN)**

**BOILER WITHOUT TANKLESS COIL AND AND HONEYWELL L8148A AQUASTAT CONTROL (BECKETT AFG BURNER SHOWN)**

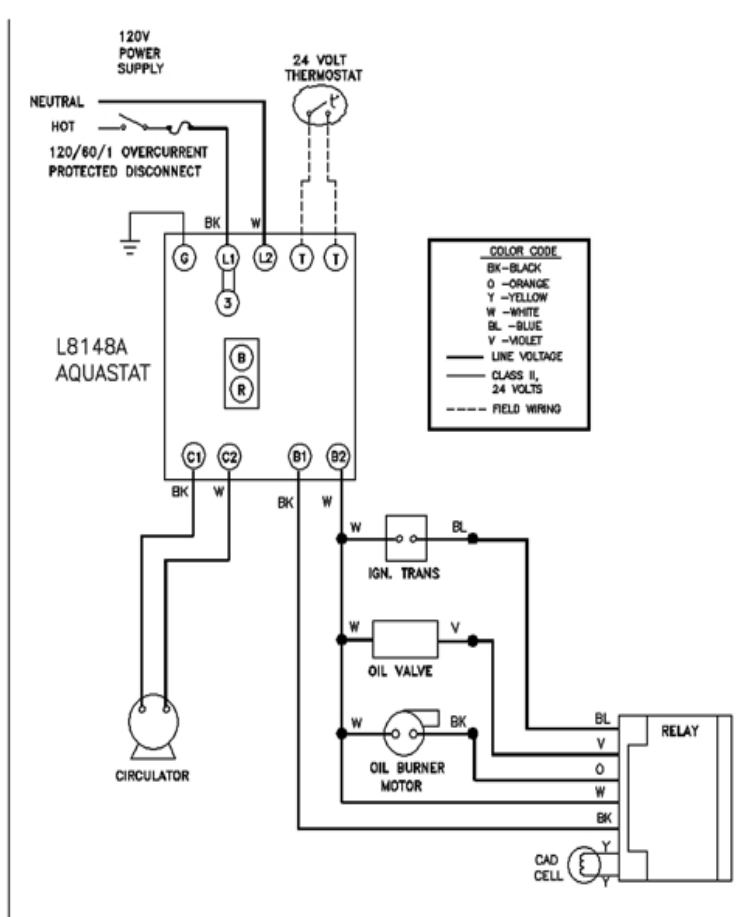
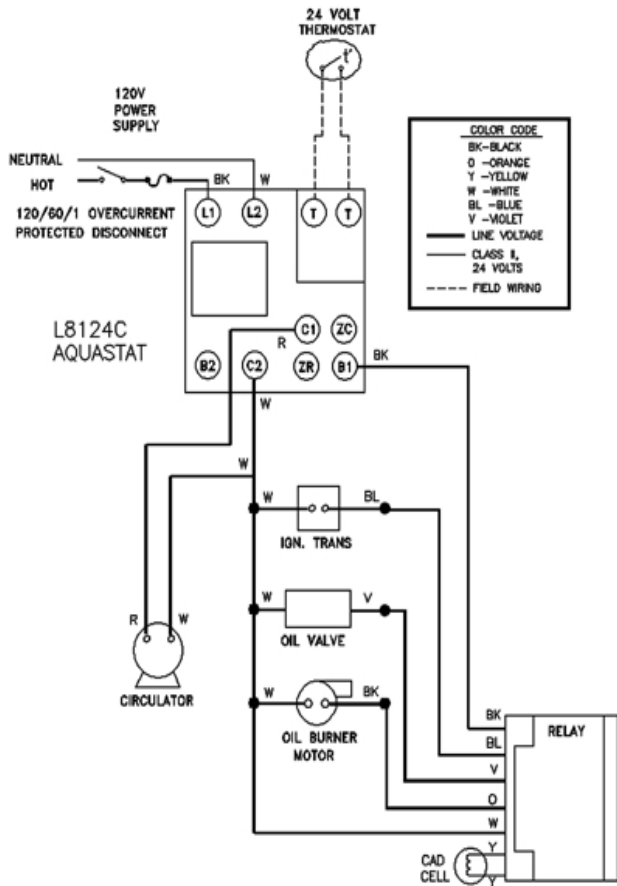

Service Company: \_\_\_\_\_

Serviceman: \_\_\_\_\_

Address: \_\_\_\_\_

Telephone: \_\_\_\_\_

## SEQUENCE OF OPERATIONS

### BOILER WITH TANKLESS COIL:

#### Aquastat high limit controller:

The aquastat control's high limit contacts open and turn off the burner when the boiler water temperature reaches the control's high limit set point. The high limit contacts automatically reset after the boiler water temperature drops past the set point by 10°F, which is a fixed differential.

#### Aquastat low limit and circulator control:

With the adjustable differential at the minimum setting of 10°F:

- On a boiler water temperature rise above the low limit set point, the burner circuit contacts (RB) break and the circulator circuit contacts (RW) make
- On a boiler water temperature drop of 10°F below the low limit set point, the RB contacts make and the RW contacts break.

With the adjustable differential setting greater than 10°F:

- When the boiler water temperature is at (or below) the low limit set point, the RB contacts make and fire the burner and the RW contacts break leaving the circulator off. The burner will fire until the boiler water temperature reaches the low limit set point **plus** the adjustable differential setting **minus** 10°F. At this point the RB contacts break stopping the burner and the RW contacts make. With no call for space heating, operating in this way keeps the circulator off and allows the boiler to give preference to the domestic water heating requirements.  
**Example: Consider the boiler water temperature drops to 150°F with the low limit set at 160°F and the differential is set at 15°F. The burner will begin to fire. When the aquastat probe senses a boiler water temperature of 165°F (15°F-10°F = 5°F, then 160°F+5°F=165°F) the RB contacts break and the RW contacts make.**

When the boiler water temperature rises above the low limit / adjustable differential setting and the thermostat controls call for domestic space

heating. The sequence of operation for the burner and circulator is as follows:

1. Thermostat calls for heat, completing circuit between terminals T & T on the aquastat controller, energizing the 1K relay coil.
2. With the 1K relay coil energized, contacts 1K1 and 1K2 are closed. Terminal B1 is energized, providing power to the oil burner primary control. This, in turn, powers the ignition coil and burner motor.
3. With the primary control energized, the burner operation starts and remains running as long as the cad cell senses flame. In the event of flame failure or the flame is not fully proven within the trial for ignition period, the primary control will lockout and open the burner circuit. This will require a manual startup of the burner.
4. As long as flame is proven through the cad cell relay, the burner will remain on until the circuit is interrupted by the boiler water temperature reaching the aquastat's high limit setting (opening high limit contacts RB), or the thermostat is satisfied breaking the TT circuit.
5. Circulator pump is powered through terminal C 1 and will run when boiler water temperature is above the low limit setting and there is a call for heat from the thermostat. If the boiler water temperature reaches the aquastat's high limit setting and high limit contact RB is de-energized, the burner stops but the circulator pump will continue to run, as long as, the thermostat calls for heat.
6. Whenever the boiler water temperature reaches the aquastat's high limit setting, the high limit contact RB is de-energized shutting the burner off. Then the boiler water temperature must fall 10°F below the aquastat's high limit setting for the high limit contacts RB to close and the burner to be energized.
7. When the thermostat is satisfied, the call for domestic space heating is ended. Relay coil 1K is de-energized, opening 1K1 and 1K2 contacts. Both the burner and circulator pump operation stop.

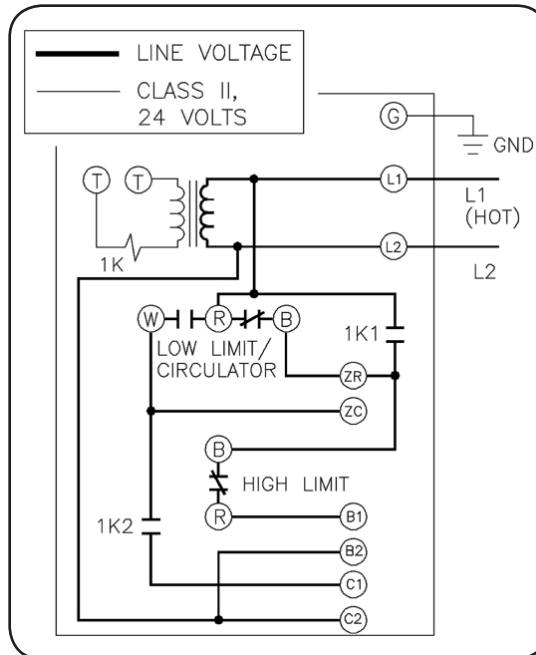

**NOTE:** High limit setting must be a minimum of 20° higher than the low limit setting.

## SEQUENCE OF OPERATIONS

### BOILER LESS TANKLESS COIL:

#### Aquastat high limit controller:

The aquastat control's high limit contacts open and turn off the burner when the boiler water temperature reaches the control's high limit set point. The high limit contacts automatically reset after the boiler water temperature drops past the set point by 10°F, which is a fixed differential.

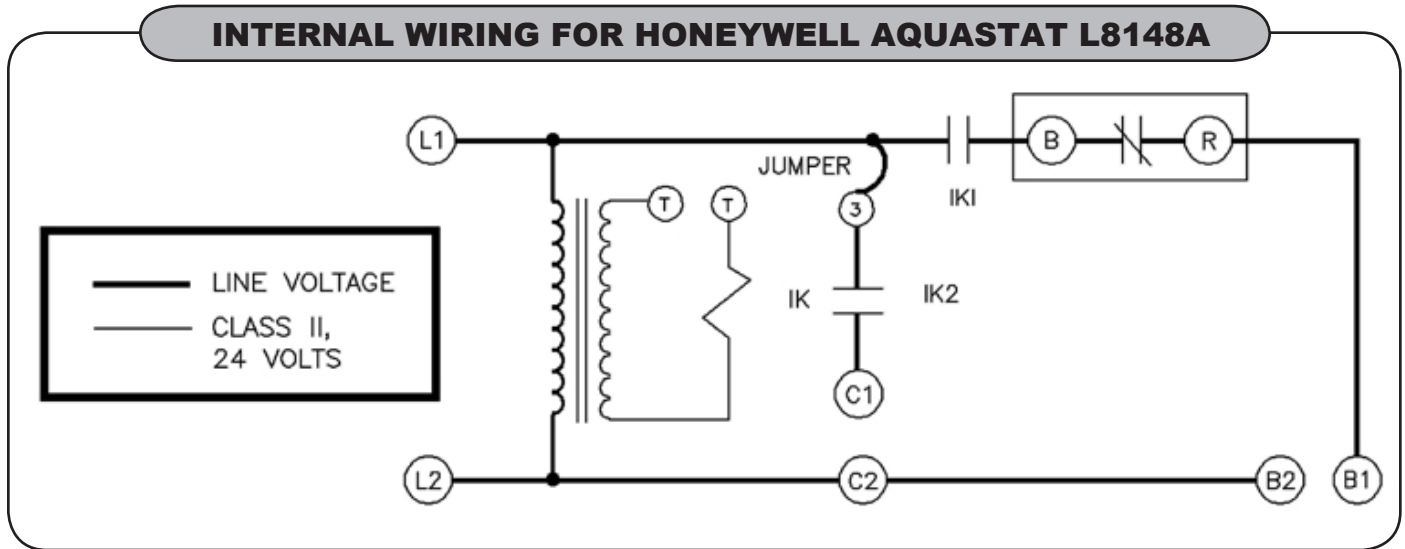

#### **When the thermostat controls call for domestic space heating. The sequence of operation for the burner and circulator is as follows:**

1. Thermostat calls for heat, completing circuit between terminals T & T on the aquastat controller, energizing the 1K relay coil.
2. With the 1K relay coil energized, contacts 1K1 and 1K2 are closed. Terminals C1 and C2 are energized providing power to the circulator. Terminal B1 is energized, providing power to the oil burner primary control. This, in turn, powers the ignition coil and burner motor.
3. With the primary control energized, the burner operation starts and remains running as long as the cad cell senses flame. In the event of flame failure or the flame is not fully proven within the trial for ignition period, the primary control will lockout and open the burner circuit. This will require a manual startup of the burner.
4. As long as flame is proven through the cad cell relay, the burner will remain on until the circuit is interrupted by the boiler water temperature reaching the aquastat's high limit setting (opening high limit contacts BR), or the thermostat is satisfied breaking the TT circuit.
5. If the boiler water temperature reaches the aquastat's high limit setting, the high limit contact BR is de-energized turning the burner off. However, the circulator pump will continue to run, as long as, the thermostat calls for heat.
6. After the high limit contact BR is de-energized, the boiler water temperature must fall 10°F below the aquastat's high limit setting for the high limit contacts BR to close and energize the burner.

When the thermostat is satisfied, the call for domestic space heating is ended. Relay coil 1K is de energized, opening 1K1 and 1K2 contacts. Both the burner and circulator pump operation stop.

# REPAIR PARTS

- 17  
1 COVER PLATE FOR BOILERS WITHOUT TANKLESS COIL NOT SHOWN
- 21  
2 1 1/4" SQUARE HEAD PLUGS NOT SHOWN
- 22  
XXX 400°F BLACK SILICONE RUBBER NOT SHOWN  
ADHESIVE SEALANT

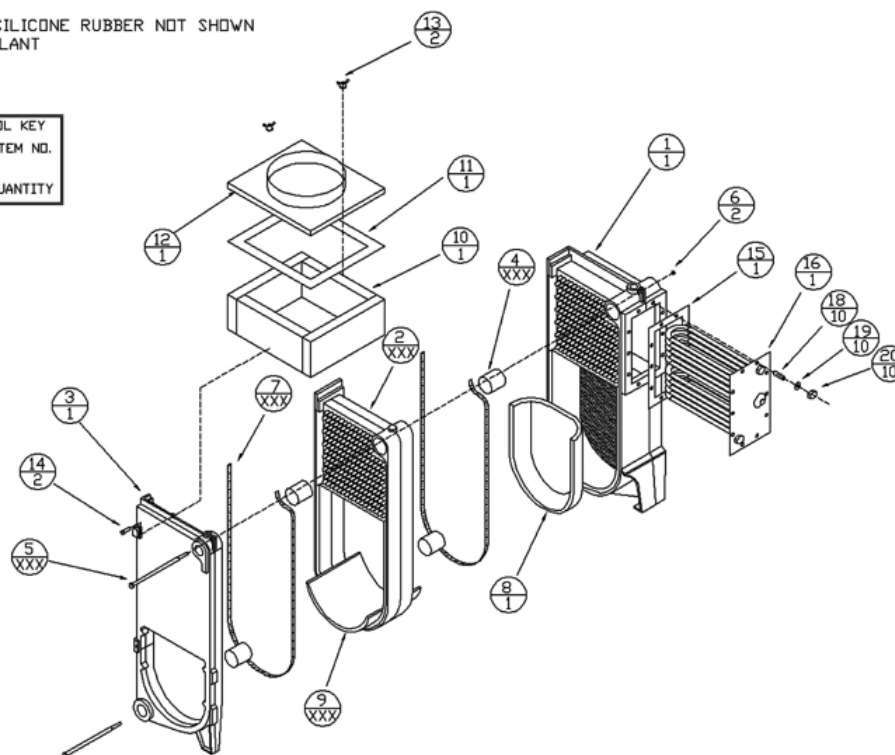
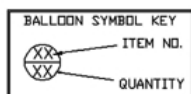

ITEM	DESCRIPTION	3EW	4EW	5EW
1	Water Boiler Back Section (EW3)	40300008	40300008	40300008
2	Water Boiler Middle Section (EW2)	40300007	40300007	40300007
3	Empire Water Front Section (EW1)	40300006	40300006	40300006
4*	Cast Iron Machined Nipples 2"	43300976	43300976	43300976
5*	1/4" Tie Rods	14605002	14605051	14605053
6	Tie Rods 1/4"20 Hex Head Nut	14695041	14695041	14695041
7*	5/16" x 701/2" Braided Rope	43300955	43300955	43300955
8	Target Wall	14619003	14619003	14619003
9*	1/2" thick Durablanket	14630031	14630031	14630031
10	Collector Base Complete (plus item 11, 12, 13)	42500279	42500280	42500281
11	Insulation Tape (plus items 10, 12, 13)	42500279	42500280	42500281
12	Collector Top (plus items 10,11,13)	42500279	42500280	42500281
13	8/32" Brass Wing Nut	13704007	13704007	13704007
14	#14 x 1" Hex Washer Head Screw	14695109	14695109	14695109
15**	Coil Housing Gasket	14693065	14693065	14693065
		CAT#94X40	CAT#94X40	CAT#94X40
16**	3.7 GPM Tankless Coil	14627020	14627020	14627020
17	Coil Housing Cover Plate (not shown)	43300256	43300256	43300256
18**	Stainless Steel 3/8"16 x 11/2" Stud	14695113	14695113	14695113
19	Stainless Steel 3/8" Flat Washer	14695114	14695114	14695114
20**	Stainless Steel 3/8" Top Lock Nut	14695115	14695115	14695115
21	1 1/4" Solid Plug (not shown)	1395002	1395002	1395002
22	Black Silicone Sealant (not shown)	14606020	14606020	14606020
‡	Battery	40300303	40300403	40300503
‡	**Rplacment Coil Kit (contains items 15, 16, 18, 20)	43360408	43360408	43360408
		CAT#65N34	CAT#65N34	CAT#65N34

\* Note: Item quantities marked XXX vary depending upon the number of sections. Four cast iron nipples for first middle replacement section and two for each additional section. Durablanket is sold as one oversized piece to be cut to fit the appropriate boiler 6" x 12" (3EW), 9" X 20" (4EW), 12" X 20" (5EW). Black silicone sealant is sold in 10.3 oz. Cartridges.

‡ Not illustrated.



## REPAIR PARTS

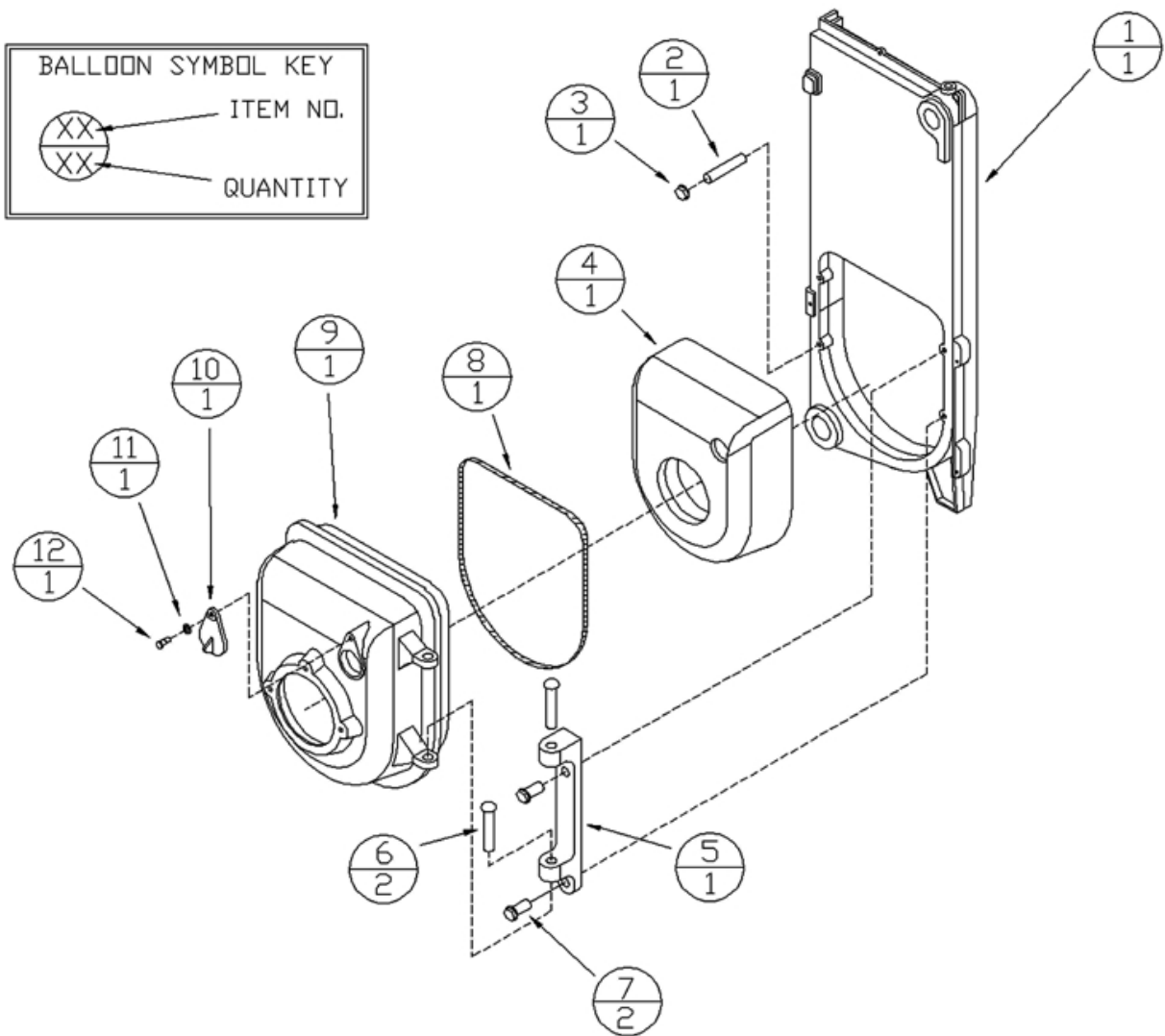

ITEM	DESCRIPTION	PART#
1	Empire Water Front Section (EW1)	40300006
2	3/8" - 16 X 2-1/4" stud	14695125
3	3/8" Whizlock Nut	14695126
4	Swing Door Insulation	14614014
5	Swing Door Hinge	40300010
6	1/4" x 2" Round Head Rivet	14695121
7	3/8" x 1" Hex Head Serrated Flange Bolt	14695124
8	3/8" x 48" Fiberfrax Round Braid	43300905
9	Swing Door	40300009
10	Observation Door	40300014
11	5/16" Lock Washer	14695123
12	3/8" x 3/8" Shoulder Bolt 5/16"-18 Thread	14695122



# REPAIR PARTS

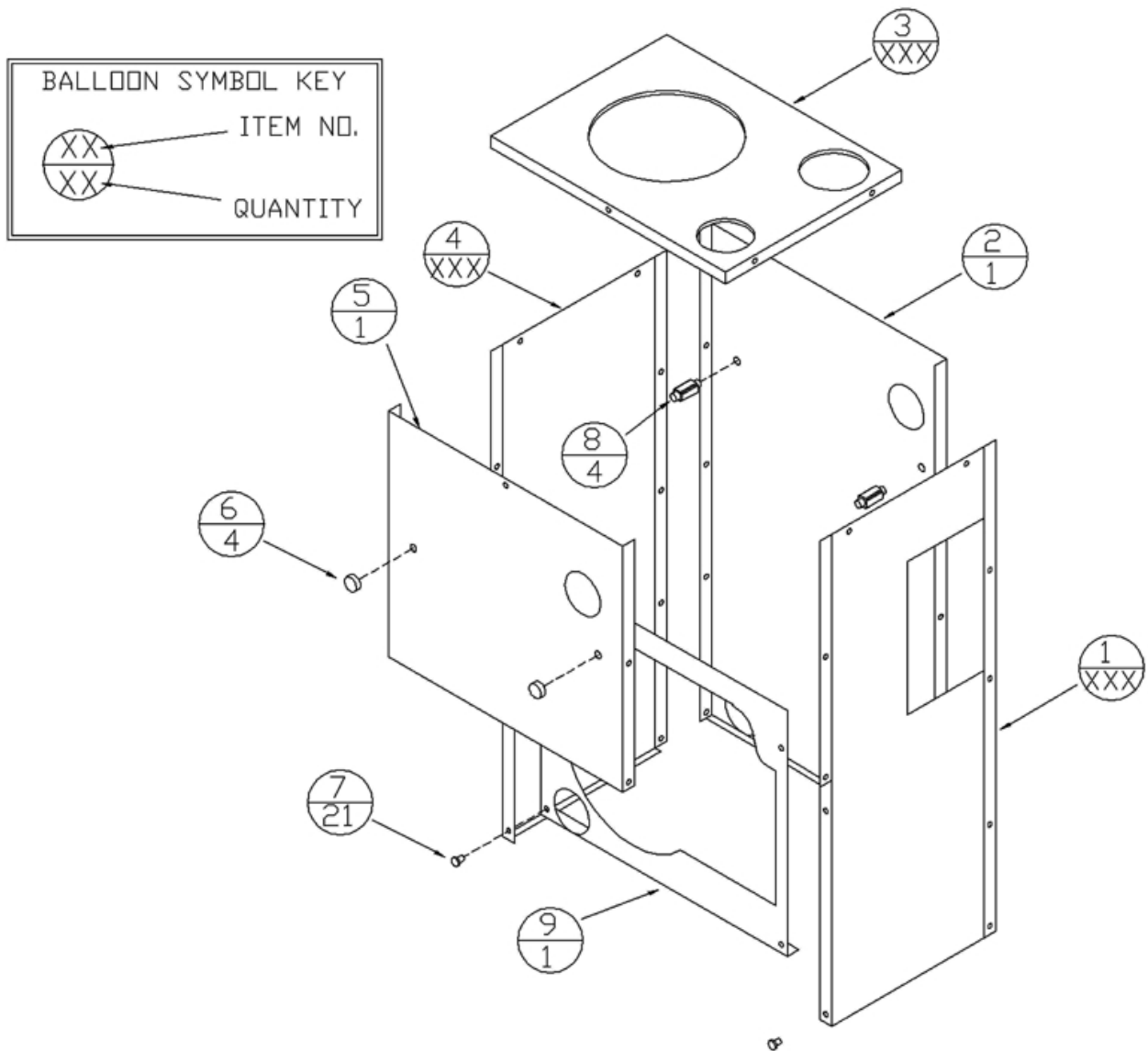

ITEM	DESCRIPTION	3EW	4EW	5EW
1	Right Side Jacket Panel	42500244AF	42500245AF	42500246AF
2	Back jacket Panel	42500269AF	42500269AF	42500269AF
3	Top jacket Panel	42500254AF	42500255AF	42500256AF
4	Left Side Jacket Panel	42500264AF	42500265AF	42500266AF
5	Upper Side Jacket Panel	42500267AF	42500267AF	42500267AF
6	5/16" Acorn Nut	14695042	14695042	14695042
7	#10 x 1/2" Jacket Screw	14695074	14695074	14695074
8	Stand Off	14695103	14695103	14695103
9	Lower Front Jacket Panel (boiler w/swing door)	42500268AF	42500268AF	42500268AF
XX	Complete Jacket for Boiler with Swing Door	42600289AF	42600290AF	42600291AF

# REPAIR PARTS

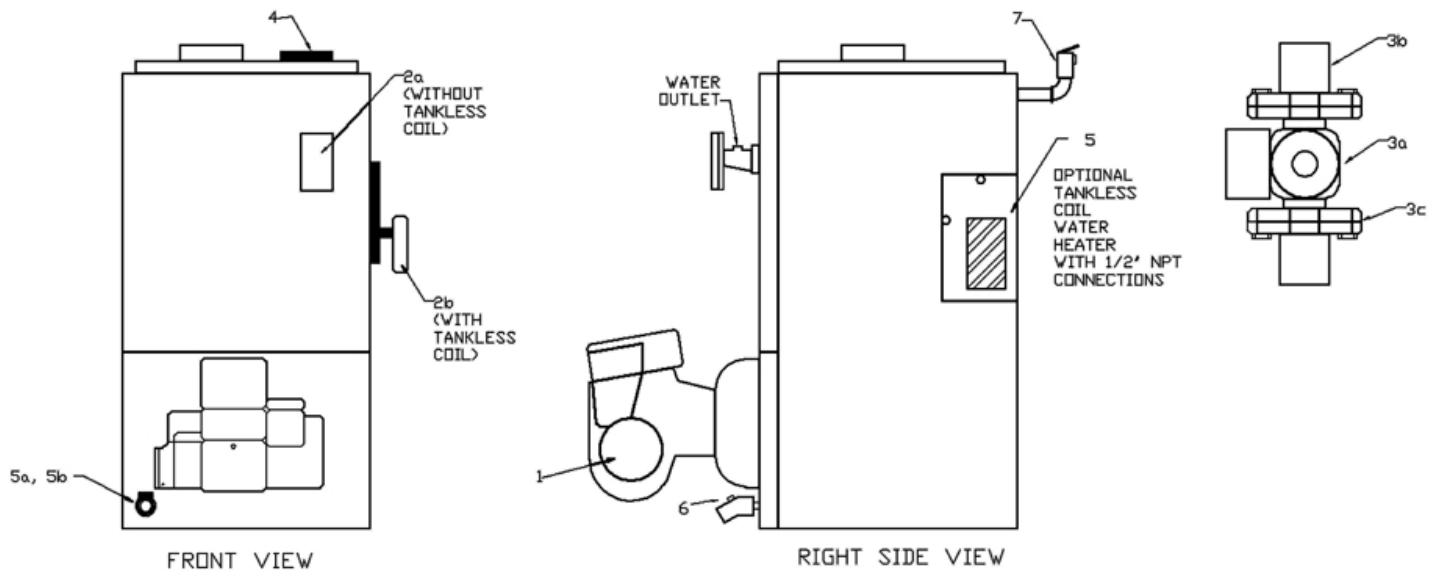

ITEM	DESCRIPTION	3EW	4EW	5EW
1	Beckett AFG FHead Oil Burner	1050036	1050037	----
1	Beckett AFG Variable Head Oil Burner	----	----	1050038
–	Beckett AFG FHead Low Fire Kit (0.65 gph)	43300015	----	----
–	Beckett AFG FHead Low Fire Kit (0.90 gph)	----	43300016	----
2a	L8148A1124 Aquastat Control (no tankless coil)	1010001	1010001	1010001
		CAT#97X74	CAT#97X74	CAT#97X74
2b	L8124C1094 Aquastat Control (with tankless coil)	14662022	14662022	14662022
		CAT#57P01	CAT#57P01	CAT#57P01
3a	Taco 007 Circulator	CI00103	CI00103	CI00103
		CAT#74P79	CAT#74P79	CAT#74P79
3b	11/4" Ball Valves	14626038	14626038	14626038
3c	Taco Circulator Gaskets	14626050	14626050	14626050
–	11/4" Flange set with gaskets, nuts, and bolts	14626049	14626049	14626049
4	Temperature/Pressure Gauge 2" Stem	1260006	1260006	1260006
5a	11/4" x 21/2" Pipe Nipple	14607044	14607044	14607044
5b	11/4" x 3/4" x 11/4" Reducing Tee	14693049	14693049	14693049
6	3/4" Drain Valve	14622000	14622000	14622000
7	3/4" Relief Valve	14622011	14622011	14622011

Note: Beckett AFG FHead low fire kits include: static plate, burner head, and oil nozzle. The temperature/pressure gauge connects to the boiler using a 3/4" x 1/4" bushing. The relief valve connects to the boiler using a 3/4" x 2" nipple and a 3/4" street elbow.

## BECKETT OIL BURNER, NOZZLE, AND AIR SETTING

BOILER MODEL	DELEVAN OIL NOZZLE	FIRING RATE (gph)	HEAD-ADJ. OR SETTING	LOW FIRE BAFFLE	AIR SHUTTER/BAND	STATIC PLATE	OIL BURNER
COWB2-3-.65*	0.50-80° B	0.65	F0 - 1 1/8	YES	10/0	3 5/8	AFG F-HEAD
COWB2-3-.75	0.65-70° B	0.75	F3 - 1 1/8	YES	10/0	3 1/2	AFG F-HEAD
COWB2-3-1.00	0.85-70° B	1.00	F3 - 1 1/8	NO	10/2	3 1/2	AFG F-HEAD
COWB2-4-.90	0.75-80° A	0.90	F3 - 1 1/8	NO	8/0	3 1/2	AFG F-HEAD
COWB2-4-1.25	1.00-80° A	1.25	F6 - 1 1/8	NO	10/0	3 3/8	AFG F-HEAD
COWB2-4-1.50	1.25-80° A	1.50	F6 - 1 1/8	NO	10/2	3 3/8	AFG F-HEAD
COWB2-5-1.20	1.00-60° B	1.20	0	NO	10/1.5	2 3/4	AFG 50 MD
COWB2-5-1.75	1.50-45° B	1.75	2	NO	10/4	2 3/4	AFG 50 MD
COWB2-5-2.00	1.65-60° B	2.00	4	NO	10/5	2 3/4	AFG 50 MD

*\*To fire the 3EW.65 on rate, the oil pressure must be increased to 175 psig. All Beckett oil burners for the EW boiler are factory preset at 140 psig.*

**NOTE: All burners use an insertion depth of 2 1/4" and fired at a over-fire draft of 0.02 inches w.c. The burner settings provided are intended for initial start up only. Final adjustment must be made using combustion test instruments.**