



GTHB

NATURAL GAS AND PROPANE GAS HIGH EFFICIENCY (CONDENSING) WARM AIR FURNACE

INSTALLATION, OPERATION & MAINTENANCE MANUAL





Manufactured by:
ECR International, Inc.
2201 Dwyer Avenue, Utica NY 13501
web site: www.ecrinternational.com

IMPORTANT: THIS MANUAL MUST BE KEPT NEAR THE FURNACE FOR FUTURE REFERENCE!!



1 - Warnings And Safety Symbols.....4
 2 - Furnace Dimensions And Clearance To Combustibles.....6
 3 - Installation Requirements7
 4 - Furnace Components8
 5 - Furnace Sizing.....9
 6 - Location Of Unit 10
 7 - Combustible Clearances..... 12
 8 - Duct work 12
 9 - Ventilation And Combustion Air..... 13
 10 - Venting And Combustion Air Piping 14
 11 - Non-Direct Vent Furnace Installations (Using Indoor Combustion Air) 15
 12 - Determining Combustion Air..... 15
 13 - Venting Guidelines 18
 14 - Terminations 21
 15 - Vent Termination Clearances..... 26
 16 - Upflow Option..... 29
 18 - Horizontal Left Option 31
 19 - Downflow Option 32
 20 - Condensate Drains 33
 21 - Gas Supply And Piping 34
 22 - Conversions..... 36
 23 - Electrical Specifications..... 38
 24 - Low Voltage Wiring 40
 25 - Optional Accessories (Field Supplied/Installed)..... 40
 26 - Startup Procedures..... 40
 27 - Air Flow..... 42
 28 - Maintenance And Troubleshooting 46
 30 - Wiring Diagram For PSC Motor 52
 31 - Venting Checklist..... 53
 32 - Replacement Parts List..... 54

1 - WARNINGS AND SAFETY SYMBOLS

	<p style="text-align: center;">DANGER</p> <p>Indicates an imminently hazardous situation which, if not avoided, WILL result in death, serious injury or substantial property damage.</p>		<p style="text-align: center;">CAUTION</p> <p>Indicates an imminently hazardous situation which, if not avoided, may result in injury or property damage.</p>
	<p style="text-align: center;">WARNING</p> <p>Indicates an imminently hazardous situation which, if not avoided, may result in death, serious injury or substantial property damage.</p>		<p style="text-align: center;">NOTICE</p> <p>Indicates information which should be followed to ensure proper installation and operation.</p>

Introduction

This 93% efficient gas fired (condensing) furnace is an upflow, downflow, horizontal left and right warm air furnace suitable for residential and light commercial heating applications from 40,000 to 120,000 BTU/Hr.

The 93% efficient furnace series is CSA design certified as a Category IV indirect or direct vent central forced air furnace. When installed as a direct vent furnace, all combustion air is supplied to the furnace burners through the air intake system. (See Section 9, "Ventilation and Combustion Air.")

All models may be fired by natural gas or LP gas (propane) and may be field converted from natural gas to LP gas.

The furnace is shipped completely assembled except for the drain trap assembly and the venting. Please inspect for damage when the furnace is unpacked.

IMPORTANT: Read the following instructions COMPLETELY before installing!!

	WARNING
	If the information in these instructions is not followed exactly, a fire or explosion may result, causing property damage, personal injury or loss of life.

	WARNING
	This product must be installed by a licensed plumber or gas fitter when installed within the commonwealth of Massachusetts.

	WARNING
	These instructions are intended as an aid to qualified service personnel for proper installation, adjustment and operation of this furnace. Read these instructions thoroughly before attempting installation or operation. Failure to follow these instructions may result in improper installation, adjustment, service or maintenance, possibly resulting in fire, electrical shock, carbon monoxide poisoning, explosion, property damage, personal injury or death.

WARNING

FOR YOUR SAFETY

Do not store or use gasoline or other flammable vapors and liquids, or other combustible materials in the vicinity of this or any other appliance.

WHAT TO DO IF YOU SMELL GAS

Do not try to light any appliance.

Do not touch any electrical switch; do not use any phone in your building.



Immediately call your gas supplier from a neighbor's phone, or a cellular phone from a location well away from the building. Follow the gas supplier's instructions.

If you cannot reach your gas supplier, call the fire department.

Do not re-enter the building until authorized to do so by the gas supplier or the fire department.

Improper installation, adjustment, alteration, service or maintenance can cause injury, property damage or loss of life. Refer to this manual.

Installation and service must be performed by a qualified installer, service agency or the gas supplier.

Safety Rules

1. Use this furnace only with type of gas approved for this furnace. Refer to the furnace rating plate.
2. Install this furnace only in dry indoor locations (protected from weather).
3. Provide adequate combustion and ventilation air to the furnace space as specified in Section 9 of this manual, "Ventilation and Combustion Air."
4. Combustion products must be discharged outdoors. Connect this furnace to an approved vent system only, as specified in Section 10 of this manual, "Venting and Combustion Air Piping."
5. Never test for gas leaks with an open flame. Use a commercially available soap solution made specifically for the detection of leaks to check all connections as specified in Section 21 of this manual, "Gas Supply and Piping."
6. Always install furnace to operate within the furnace's intended temperature-rise range with a duct system, which has an external static pressure within the allowable range, as specified in Sections 5, 8, and 27 of this manual, "Furnace Sizing," "Duct work," and "Airflow."

1 - WARNINGS AND SAFETY SYMBOLS

7. When a furnace is installed so that the supply ducts carry air circulated by the furnace to areas outside the space containing the furnace, the return air shall also be handled by duct(s) sealed to the furnace casing and terminating outside the space containing the furnace. (Furnace for heating the home located in the attached garage, for example).
8. A gas-fired furnace for installation in a residential garage must be installed so that the burners and ignitor are no less than 18" above the floor. The furnace must be located, or protected to avoid physical damage by vehicles. (See safety warning).
9. This furnace is not to be used for temporary heating for buildings under construction.

Codes

1. This furnace must be installed:
 - A. In accordance with all local codes, by-laws and regulations by those authorities having jurisdiction.
 - B. In Canada, this furnace must be installed in accordance with the current CAN/CGA -B149 Installation Code for Natural Gas and Propane Installations.
 - C. In the United States, this furnace must be installed in accordance with the current ANSI Z223.1 (NFPA 54) National Fuel Gas Code.
2. Electrical connections must be made in accordance with:
 - A. Any applicable local codes, by-laws and regulations.
 - B. Canada: current edition of CAN/CSA C22.1, Canadian Electrical Code (Part 1).
 - C. United States: current edition of ANSI/NFPA 70, National Electrical Code.

Codes and additional information may be obtained from:

Canadian Standards Association
5060 Spectrum Way
Mississauga, Ontario, L4W 5N6
Phone: (416) 747-4000

American Gas Association
400 North Capitol Street, NW, Suite 450
Washington DC, 20001
Phone: (202) 824-7000

National Fire Protection Association
1 Batterymarch Park
Quincy, MA, 02169-7471
Phone: (617) 770-3000

WARNING



Do not install this furnace in a mobile home! This furnace is not approved for installation in a mobile home. Doing so could cause fire, property damage, personal injury or loss of life.

WARNING



The furnace contains foil covered fiberglass insulation. Inhalation of fiberglass particles is associated with respiratory disease including cancer.

WARNING



Natural gas and propane are normally odorized by the fuel supplier. In some cases, the odorant may not be perceivable. Installation of UL and ULC recognized fuel gas detectors installed in accordance with their manufacturer's instructions is recommended as an additional margin of safety.

WARNING



The exhaust gases from this furnace contain chemicals which on some occasions may include carbon monoxide (CO). Carbon monoxide is an odorless, tasteless, clear colorless gas which is highly toxic. Even low concentrations are suspected of causing birth defects and other reproductive harm.

UL and ulc recognized CO detectors are recommended for all buildings equipped with fossil fuel burning appliances. All CO detectors should be installed in accordance with their manufacturer's instructions and applicable local building codes.

WARNING



When this furnace is installed in a residential garage, it must be installed so the burners and ignition source are located no less than 18" above the floor to prevent the risk of igniting flammable vapors which may be present in the garage.

The furnace must be located or protected to avoid physical damage by vehicles.

Failure to heed these warnings can cause a fire or explosion, resulting in property damage, personal injury or loss of life.

2 - FURNACE DIMENSIONS AND CLEARANCE TO COMBUSTIBLES

Figure 1 - Furnace Dimensions And Clearance To Combustibles

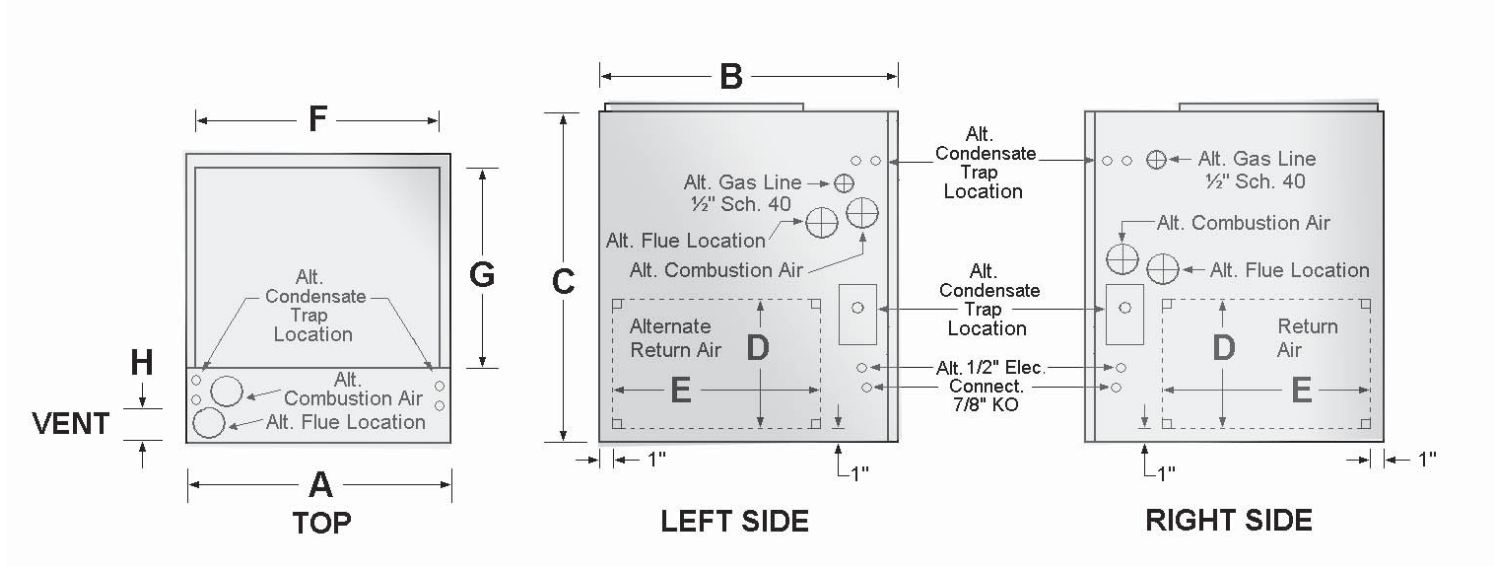

TABLE 1A - FURNACE DIMENSIONS						
Model	Width A	Depth B	Height C	Vent H	Supply Air (F x G)	Return Air (D x E)
40/60	16 ⁷ / ₈ "	29"	40"	2"	15 ⁷ / ₈ x 20	14 x 22
80	18 ¹ / ₂ "	29"	40"	2"	17 ¹ / ₂ x 20	14 x 22
100	20 ¹ / ₂ "	29"	40"	2"	19 ¹ / ₂ x 20	14 x 22
120	23 ¹ / ₂ "	29"	40"	2"	22 ¹ / ₂ x 20	14 x 22

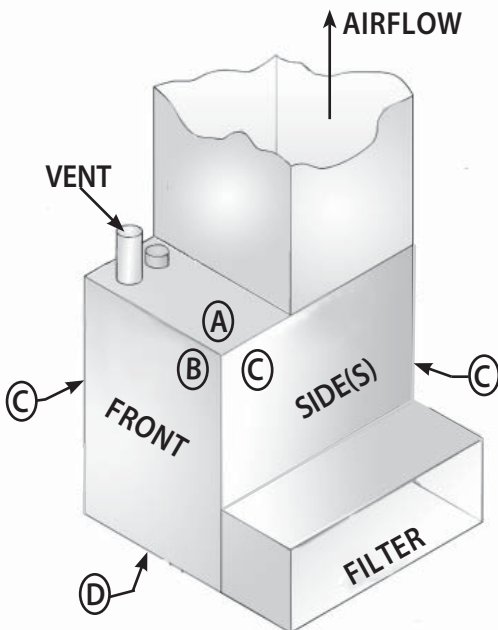

TABLE 1B - FURNACE CLEARANCE TO COMBUSTIBLES	
SIDE	Distance
A	1" or Non-Combustible Floor
B	0", Service Clearance 24 Inches or more
C	0"
D	Combustible Floor (must not be placed on carpet non-ceramic tile)
All models are approved for closet installation	

For down-flow installations use optional
sub-base kit 550001346

3 - INSTALLATION REQUIREMENTS

Installation Requirements Specific To The State Of Massachusetts For Direct Vent, Mechanical Vent, And Domestic Hot Water Appliances.

For all side wall horizontally vented gas fueled equipment installed in every dwelling, building or structure used in whole or in part for residential purposes, including those owned or operated by the commonwealth and where the side wall exhaust vent termination is less than seven feet above finished grade in the area of the venting, including but not limited to decks and porches, the following requirements shall be satisfied:

1. INSTALLATION OF CARBON MONOXIDE DETECTORS:

At the time of installation of the side wall horizontal vented gas fueled equipment, the installing plumber or gasfitter shall observe that a hard wired carbon monoxide detector with an alarm and battery back-up is installed on the floor level where the gas equipment is to be installed. In addition, the installing plumber or gasfitter shall observe that a battery operated or hard wired carbon monoxide detector with an alarm is installed on each additional level of the dwelling, building or structure served by the side wall horizontal vented gas fueled equipment. It shall be the responsibility of the property owner to secure the services of qualified licensed professionals for the installation of hard wired carbon monoxide detectors.

A. In the event that the side wall horizontally vented gas fueled equipment is installed in a crawl space or an attic, the hard wired carbon monoxide detector with alarm and battery back-up may be installed on the next adjacent floor level.

B. In the event that the requirements of this subdivision can not be met at the time of completion of installation, the owner shall have a period of thirty (30) days to comply with the above requirements; provided, however that during said thirty (30) day period, a battery operated carbon monoxide detector with an alarm shall be installed.

2. APPROVED CARBON MONOXIDE DETECTORS: Each carbon monoxide detector as required in accordance with the above provisions shall comply with NFPA 720 and be ANS/UL 2034 listed and IAS certified.

3. SIGNAGE: A metal or plastic identification plate shall be permanently mounted to the exterior of the building at a minimum height of eight (8) feet above grade directly in line with the exhaust vent termination for the horizontally vented gas fueled heating appliance or equipment. The sign shall read, in print size no less than one-half (1/2) inch in size. "GAS VENT DIRECTLY BELOW. KEEP CLEAR OF ALL OBSTRUCTIONS".

4. INSPECTION: The state or local gas inspector of the side wall horizontally vented gas fueled equipment shall not approve the installation unless, upon inspection, the inspector observes carbon monoxide detectors and signage installed in accordance with the provisions of 248 CMR 5.0(2)(a)1. through 4.

- 5. EXEMPTIONS:** The following equipment is exempt from 248 CMR 5.08(2)(a)1. through 4.
- A. The equipment listed in Chapter 10 entitled "Equipment Not Required To Be Vented" in the most current edition of NFPA54 as adopted by the Board; and
 - B. Product Approved side wall horizontally vented gas fueled equipment installed in a room or structure separate from the dwelling, building or structure used in whole or in part for residential purposes.

6. MANUFACTURER REQUIREMENTS

A. GAS EQUIPMENT VENTING SYSTEM PROVIDED.

When the manufacturer of Product Approved side wall horizontally vented gas equipment provides a venting system design or venting system components with the equipment, the instructions provided by the manufacturer for installation of the equipment and the venting system shall include:

- Detailed instructions for the installation of the venting system design or the venting system components; and
- A complete parts list for the venting system design or venting system.

B. GAS EQUIPMENT VENTING SYSTEM NOT PROVIDED. When the manufacturer of a Product Approved side wall horizontally vented gas fueled equipment does not provide the parts for venting the flue gases, but Identifies "special venting systems", the following requirements shall be satisfied by the manufacturer:

- The referenced "special venting system" instructions shall be included with the appliance or equipment installation instructions; and
- The "special venting systems" shall be Product Approved by the Board, and the instructions for that system shall include a parts list and detailed installation instructions.

7. INSTALLATION INSTRUCTIONS: A copy of all installation instructions for all product approved side wall horizontally vented gas fueled equipment, all venting instructions, all parts lists for venting instructions, and/or all venting design instructions shall remain with the appliance or equipment at the completion of the installation.

4 - FURNACE COMPONENTS

Figure 2 - Furnace Components

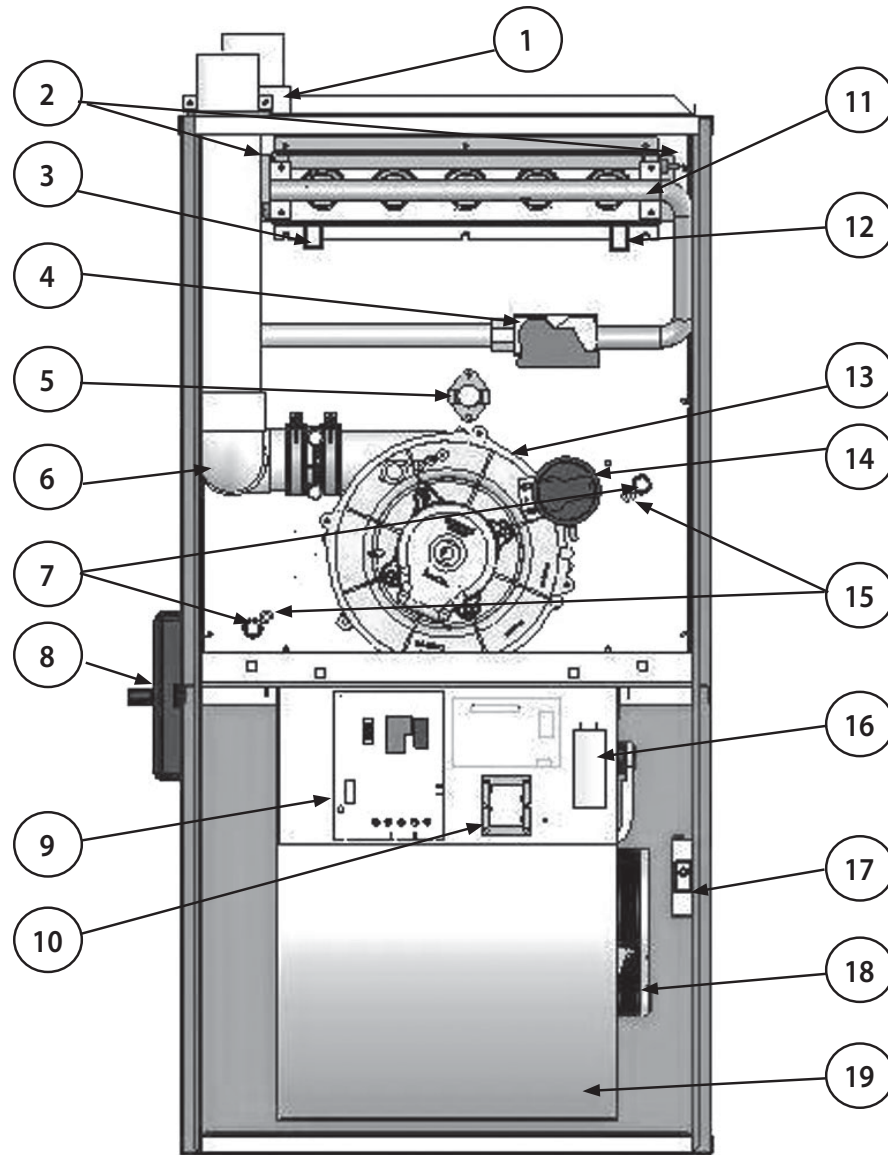

Item	Description	Qty	Item	Description	Qty
1	Combustion Air Intake Fitting	1	11	Burner Assembly	1
2	Flame Roll-out Switch (2)	2	12	Igniter	1
3	Flame Sensor	1	13	Induced Draft Blower (Ventor)	1
4	Gas Valve	1	14	Pressure Switches	1
5	Air High Temperature Limit	1	15	Front Manifold Cover Pressure Tap	2
6	Vent and Drain Assembly	1	16	Blower Motor Start Capacitor	1
7	Drain for Recovery Coil	2	17	Door Switch and Junction Box	1
8	Condensate Trap	1	18	Blower Motor	1
9	Integrated Control Board	1	19	Blower	1
10	Transformer for 24 VAC	1			

5 - FURNACE SIZING

The maximum hourly heat loss for each heated space shall be calculated in accordance with the procedures described in the manuals of the Heating, Refrigeration and Air Conditioning Institute of Canada (HRAI), or by any other method which is suitable for local conditions, provided the results obtained are in substantial agreement with, and not less than those obtained using the procedure described in their manuals.

In the United States, “Manual J - Load Calculation,” published by the Air Conditioning Contractors of America, describes a suitable procedure for calculating the maximum hourly heat loss.

If the installation is a retrofit application, do not rely on the capacity of the existing heating equipment as a method to size the new furnace. Many of the heat transfer multiples listed in earlier versions of load calculation manuals were much higher than those listed in more recent editions. It is possible that energy saving measures have been completed since the installation of the existing furnace. This might include additional insulation in the attic or walls, the application of sprayed foam insulation, the addition of storm windows and doors, weather-stripping, caulking, etc.

Many of the older furnaces were equipped with large belt drive blower systems, operating at low RPM's. If replacing an existing furnace, be sure that the existing duct work can handle the amount of airflow necessary for a reasonable temperature rise. Most older gas furnaces operated with a system temperature rise of 70 - 100°F. This furnace is designed to be operated with a system temperature rise (ΔT) of 35 - 65°F. If the furnace selected has an identical output capacity as the original furnace, a substantial increase in system air flow will be required. See **Tables 2A and 2B** (below) and the airflow characteristics in Section 27 of this manual, “Airflow.”

branch run is 600 fpm, and should not exceed 900 fpm. These values are slightly lower for flexible ducting. The recommended air velocity of a return air trunk duct is 600 fpm, and should not exceed 700 fpm. The recommended and maximum air velocity of a return air branch 600 fpm.

The “Equal Friction Chart,” as published by ASHRAE and HRAI, is the basis for the various air duct calculators available through heating supply companies. Following the air velocity guide lines, according to the “Equal Friction Chart,” or a slide rule air duct calculator, a typical 6” round duct has a capacity of approximately 100 cfm.

NOTICE

NOTE: The return air system is equally as important as the supply air system. An under-sized return air system will prevent sufficient quantities of air from reaching the supply air system and will consequently reduce the service life of the furnace and its components.

TABLE 2A - RANGE OF TEMPERATURE RISE

Furnace Model	Temperature Rise
40, 60, 80, 100, 120	35 – 65°F

TABLE 2B - AIR FLOW FOR TEMPERATURE RISE

Furnace Model	CFM Required for a ΔT of:			
	35	45	55	65
40	980	762	623	527
60	1469	1143	935	791
80	1959	1524	1247	1055
100	2449	1905	1558	1319
120	2939	2286	1870	1582

Existing duct work should be assessed for its air handling capabilities. For residential applications, the recommended air velocity of a supply air trunk duct is 700 feet per minute (fpm), and should not exceed 900 fpm. The recommended air velocity of a supply air

6 - LOCATION OF UNIT

1. General Guidelines

- A. Select a location where the exhaust and combustion air piping can be routed between the furnace and their terminations with a minimum of lengths and fittings. Be sure to check that the proposed termination location will meet code requirements with respect to location and minimum clearances. (See venting section for minimum and maximum limits.)
- B. Select a location as near as possible to the existing or proposed duct system.
- C. The furnace location must have provisions for condensate drainage. If a suitable drain is unavailable near the furnace, a condensate pump must be used. The condensate pump drain tubing must not terminate outdoors; similar to some air conditioning condensate installations. Be sure to select a condensate pump that has been approved for furnace condensate applications.
- D. The furnace location must permit access for servicing and be within the clearance to combustibles guidelines as marked on the appliance rating plate.
- E. The furnace must be installed level to allow for the proper drainage of condensate. The furnace may shut down during winter operation if the condensate does not drain freely away from the furnace.
- F. The furnace should be installed on a firm base when installed in the upflow position. This could typically be the concrete floor if installing the furnace in a basement.
- G. If the furnace is being installed so that the return air will enter through the bottom, the perimeter of the furnace must be properly supported.
- H. When installed in the horizontal position, the furnace may be supported from the bottom, or suspended. (**Figure 3**)
- I. If the furnace is to be installed in a commercial (repair) garage, the burners and ignition source must be a minimum of 4½ feet (1375 mm) above the floor. The furnace must be protected from physical damage by metal barriers or other acceptable means.

2. Other Considerations

- A. If the furnace is to be located in an area where the combustion air is laden with chemical compounds such as bromine, chlorine or fluorine, as may be found in swimming pool chemicals, laundry detergents, etc., use outdoor air for combustion. These compounds when exposed to flame, form acids which attack the heat exchanger and other components. A partial list of contaminants would include:
 - Aerosols, particularly CFC based aerosols
 - Air fresheners
 - “Airplane” glue and similar cements
 - Ammonia, as is commonly found in permanent wave solutions used in women’s hair dressing salons
 - Anti-static fabric softeners used in clothes dryers
 - Carbon tetrachloride
 - Chlorinated cleaners and waxes
 - Chlorine and bromine based swimming pool chemicals and treatments
 - De-icing salts or chemicals, rock salt, etc.
 - Dry cleaning solutions such as perchloroethylene
 - Halogen based refrigerants including R-12 and R-22
 - Hydrochloric acid, muriatic acid, or other acid based masonry washing compounds
 - Polyurethane and similar derivatives fumes
 - Printer’s inks, paint removers, furniture strippers, varnishes, varsol, toluene, etc.
 - Water softener salts and chemicals.

NOTICE

IMPORTANT: This furnace is not to be used for temporary heating of buildings or structures under construction.

Figure 3 - Suggested Method For Suspending Horizontal Furnace

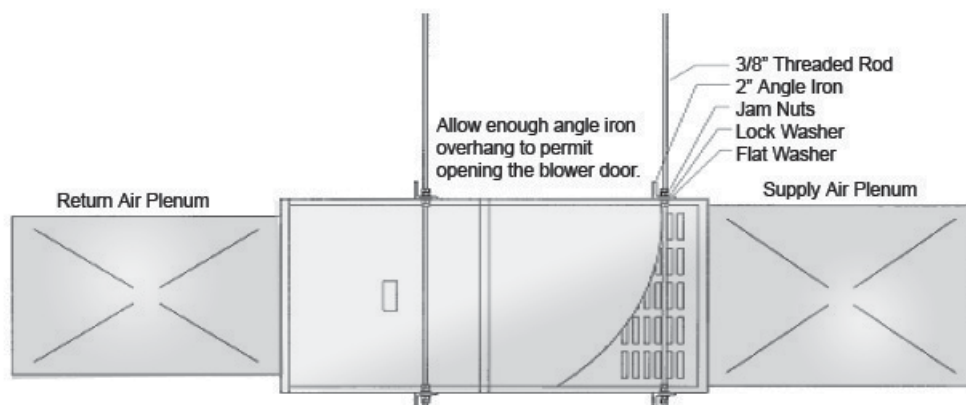

- B. If this furnace is to be installed in an area over a finished ceiling or living area, install a field fabricated auxiliary drain pan under the furnace to protect that area from accidental condensate spills. The auxiliary pan should be large enough to collect accidentally spilled condensate from the air conditioning evaporator coil assembly if applicable.

NOTICE

NOTE: These furnaces are approved for installation in attics, alcoves, utility rooms, closets and crawl spaces. If this furnace is to be installed in a utility room, be sure that it is located in such a way as to allow access for servicing or the removal of other appliances installed in the room (hot water heater, for example).

- C. If the furnace is installed in an area where freezing may occur, a garage, an attic, a crawl space or any unconditioned space, steps must be taken to protect the condensate trap and drain line from freezing. One possible measure could be to use a self-regulating 5 or 6 watt per foot heat tape covered with a jacket of insulation. Heat tapes are available in plumbing supply houses.

3. INSTALLATION IN UPFLOW, DOWNFLOW OR HORIZONTAL POSITIONS:

- UPFLOW INSTALLATION: Vent positioning, pressure switch location and drain locations shall be performed in accordance with instructions in the appropriate sections of this manual.
- HORIZONTAL INSTALLATION: Vent positioning, pressure switch location and drain locations shall be performed in accordance with instructions in the appropriate sections of this manual.
- NON-SUSPENDED INSTALLATION: Maintain clearances to combustibles as outlined in **Figure 1, Table 1A**. The furnace must be supported in such a way as to not allow twisting or sagging of the cabinet.
- SUSPENDED INSTALLATION: Maintain clearances to combustibles as outlined in **Figure 1, Table 1A**. The furnace may be suspended by field fabricating a cradle of angle iron and threaded rod. Secure the furnace with 2” minimum slotted angle or equivalent as shown in **Figure 3**. The furnace must be supported in such a way as to not allow twisting or sagging of the cabinet. Position the supports so as to not interfere with accessing the burner and blower compartments.
- DOWNFLOW INSTALLATION: Vent positioning, pressure switch location and drain locations shall be performed in accordance with instructions in the appropriate sections of this manual.

The opening in the floor must provide adequate clearances to the combustible material. According to the clearance to combustible table, a 1/2” clearance will be required between the plenum and the combustible material. If installed on a non combustible material, zero clearance is required. Optional subbase kit 550001346 will assist in achieving required clearances.

NOTICE

IMPORTANT: The rear of the furnace must be elevated 1/4” higher than the front from a level position to facilitate proper condensate drainage.

NOTICE

IMPORTANT: If the furnace and air conditioner is above a finished space, install a drain pan underneath the unit.

NOTICE

NOTE: It is not permissible to use a rear return on this appliance. Use only side and end returns.

- 4. AIR CONDITIONING:** This furnace may be used as part of an air conditioning system. The furnace wiring and control system is “air conditioning ready.” There are the following factors to consider:

- The air conditioning evaporator coil must be downstream of the heat exchanger. The cooled air passing over the warmer heat exchanger tubes can cause condensation inside the tubes, resulting in corrosion and premature failure.
- A parallel duct system can be installed to direct the air from the furnace through the evaporator coil only. Use dampers or other means to bypass the heat exchanger. If (summer/winter) dampers are used, they should be interlocked to prevent system operation unless the dampers are in the full open or full closed position.

7 - COMBUSTIBLE CLEARANCES

Combustible Clearances

Figure 1, Table 1A provides the certified clearances to combustibles and dimensional information. Also see the appliance rating plate affixed to the furnace for specific model number, serial number and clearance to combustibles information.

NOTICE

IMPORTANT: This furnace requires a minimum of 24" of front clearance for service purposes. For this purpose, service clearance takes precedence over clearance to combustibles.

WARNING

This furnace is design certified for installation on combustible floors. This shall be interpreted as a wood floor only.



The furnace must not be installed directly on carpeting, tile, or other combustible material except wood.

Installation on combustible material can result in fire, causing property damage, personal injury or death.

WARNING

The area around the furnace must be kept clear and free of all combustible materials including gasoline and other flammable vapors and liquids.

The homeowner should be cautioned that the furnace area must not be used as a broom closet or for any other storage purpose.

Inspection / Access Panel

If an air conditioning coil is not to be used in the supply air plenum, it is recommended that the outlet duct be provided with a removable access panel which is accessible when installed so the heat exchanger may be inspected for possible openings using light assistance or a probe that can be inserted for sampling the air stream. The access cover must be fabricated in such a manner as to prevent leaks.

8 - DUCT WORK

Proper airflow is required for the correct operation of this furnace. Insufficient airflow may cause erratic operation, could cause the furnace to cycle on the high temperature limit, and may damage the heat exchanger. Excessive airflow may result in an excessively noisy duct system and may result in undesirable consequences such as creating uncomfortable drafts and causing drapes or curtains to blow around.

If air conditioning is to be used with the furnace, the duct system must be capable of delivering the correct amount of airflow for each system.

The duct work should be sized and constructed in accordance with accepted industry standards. Duct sizing and construction information may be obtained from:

- A.C.C.A. (Air Conditioning Contractors of America)
- A.S.H.R.A.E. (American Society of Heating, Refrigeration and Air Conditioning Engineers)
- H.R.A.I. (Heating, Refrigerating and Air Conditioning Institute (Canada))
- S.M.A.C.N.A. (Sheet Metal and Air Conditioning Contractors' National Association (United States))

All of the above professional organizations have duct sizing manuals available.

The total static pressure drop of the air distribution system (including filters) should not exceed ½" w.c.

WARNING



Do not allow gas piping to be routed through joist spaces that are used for return air purposes. Do not use joist spaces for return air purposes if the joist space already contains plumbing stacks, chimney components, etc. Unless the portion used for return air purposes can be completely isolated from portions with other usages.

WARNING



Failure to prevent products of combustion from being circulated into the living space can create potentially hazardous conditions, including carbon monoxide poisoning that could result in personal injury or death.

Do not, under any circumstances, connect return or supply air duct work to or from any other heat producing device such as a fireplace insert, stove, etc. Doing so may result in fire, carbon monoxide poisoning, explosion, personal injury, loss of life, or property damage.

8 - DUCT WORK

WARNING

Never allow the products of combustion from the flue to enter the return air or supply air duct work.

All return air duct work must be adequately sealed and secured to the furnace with sheet metal screws. Tape the sheet metal seams in the vicinity of the furnace with duct tape or similar material.

When the furnace is mounted on a platform with return air through the bottom, it must be sealed air tight between the furnace and the return air plenum. The floor or platform must provide sound physical support of the furnace without sagging, cracks or gaps around the base, providing a seal between the support and the base.

Models capable of 5 tons of airflow for air conditioning must have dual return air inlets for optimal airflow and air filtration. If not specifically stated by the filter manufacturer, for effective air filtration assume a maximum velocity of 300 FPM for disposable type filters or 600 FPM for permanent type air filters.

GUIDE: Filter free area (in²) = 144 x (CFM / desired velocity (FPM))

NOTICE

IMPORTANT: Some high efficiency filters have a greater than normal resistance to airflow. This can adversely affect furnace operation.

Duct work Steps

1. Position the furnace to minimize duct work length and fittings.
2. Cut open a return air inlet. The choices are furnace bottom, either side, or any combination thereof (i.e., two sides or a side and the bottom).

WARNING

DO NOT USE THE REAR PANEL AS A RETURN AIR INLET. There is insufficient room to permit adequate airflow.

In all cases, cut the inlet air opening the full width of the knockouts.

3. Connect the return air duct or filter fitting to the furnace. The connection should be sealed air tight to prevent entraining combustion gases from an adjacent fuel burning appliance, or entraining combustion air for this furnace or adjacent fuel burning appliances.
4. Ensure that there is adequate space and accessibility for air filter removal.

NOTE: If two return air inlets are used, both must be equipped with filters.

5. If an air conditioning evaporator coil is required, position it on the supply air side of the furnace. Ensure that no air can bypass the evaporator coil.
6. Connect the supply air plenum to the supply air outlet.

FLEXIBLE DUCT CONNECTORS are an effective device to prevent the telegraphing of mechanical noise from the furnace to other parts of the home via the duct work. If using flexible connectors, ensure that the adjoining duct is independently supported.

9 - VENTILATION AND COMBUSTION AIR

WARNING

READ, UNDERSTAND AND FOLLOW ALL INSTRUCTIONS IN THIS SECTION. FAILURE TO PROPERLY VENT OR SUPPLY COMBUSTION AIR TO THIS FURNACE CAN CAUSE CARBON MONOXIDE POISONING, OR AN EXPLOSION OR FIRE, RESULTING IN PROPERTY DAMAGE, PERSONAL INJURY OR LOSS OF LIFE.

Definitions

“*Vent and Chimney*” refer to open passageways that convey vent gases from the furnace, or its vent connector to the outside. Vents can be horizontal or vertical. When they serve only one gas appliance, they are called “dedicated” vents or chimneys. When they serve multiple gas appliances, they are called “common” vents or chimneys.

“*Vent Connector*” refers to a pipe or duct that connects the furnace

to a vent or chimney. Vent connectors usually run from the furnaces vent collar to the vent or chimney. Vent connectors may have vertical and horizontal runs.

“*Venting System*” refers to a continuous open passageway from the vent collar to the outside. Venting systems usually have a vent connector(s) and a vent or chimney. Venting systems commonly serve a single furnace, or a single furnace and a hot water heater. Other multiple appliance venting systems are less common.

“*Fan Assisted Combustion System*” refers to an appliance equipped with an integral mechanical means to either draw or force products of combustion through the combustion chamber and/or heat exchanger. This series furnace uses a draft inducer to draw combustion products through the heat exchanger and is considered to have a fan-assisted combustion system. Category IV furnaces with fan-assisted combustion systems must not be vented into single wall metal vents.

General Considerations

If this furnace is to replace a Category I type furnace connected to a chimney serving other appliances, steps must be taken to ensure that the remaining appliances will vent properly after the removal of the existing furnace. There is a probability that the existing chimney will be too large.

Remove the vent connector of the furnace being replaced, seal off the inlet to the vent from that furnace, then test the remaining appliances connected to the common vent individually following these steps:

1. Permanently seal any unused openings into the common vent system.
2. Visually inspect the venting system for proper size and horizontal pitch and determine that there is no blockage, restriction, leakage, corrosion, collapsed materials such as fallen bricks, or any other deficiency that could lead to an unsafe condition.
3. Insofar as practical, duplicate winter operating conditions such as closing all windows and doors in the building. If the remaining appliances are in a mechanical room, close the door to the room. Close the fireplace dampers if any, turn on any appliances that exhaust air to the outdoors on maximum speed. This would include clothes dryers, range hoods, bathroom fans, etc. Attic fans or other fans used only in summer should be exempted from the test.
4. Follow the lighting instructions of the appliance being tested and turn it on to continuous operation.
5. Test for spillage at the draft hood relief opening after 5 minutes of main burner operation. Detect for spillage using a match flame, taper (candle).
6. After it has been proven that each appliance to remain connected to the common venting system properly vents when tested as listed above, return the windows, doors, fireplace dampers, appliances, etc. to the condition they were in prior to the test.
7. If improper venting is observed during any of the tests, the common venting system must be re-sized. In Canada, refer to the latest addition if CAN/GGA-B149, Natural Gas or Propane Installation Code. In the United States, refer to the latest ANSI Z223.1 National Fuel Gas Code (NEPA 54), or AGA-GAMA Venting Tables for Category I furnaces.

10 - VENTING AND COMBUSTION AIR PIPING

The furnace products of combustion include both flue gases and condensate. All venting and drain materials are plastic.

Acceptable Materials In The United States

For United States installations, the combustion air and vent piping may be comprised of:

- Schedule 40 PVC, ASTM D1785 or CSA B137.3
- PVC-DWV, ASTM D2665 or CSA B181.2
- Schedule 40 CPVC, ASTM F441 or CSA B137.6
- PVC primer and solvent cement: ASTM D2564

Follow piping manufacturers instructions on proper installation of piping and fittings including cutting, de-burring, priming, cementing, curing and supporting.

Acceptable Materials In Canada

Effective August 1, 2007, all vent piping materials and fittings for flue gas venting must be ULC S636 listed and identified as such on the material. The first 3ft. (900mm) of venting must be readily available for visual inspection. Specified primers and glues of the certified vent system must be from a single system manufacture, and not intermixed with other system manufacture's vent system parts. The components of the certified vent system must not be interchanged with other vent systems, or unlisted pipe, and or fittings. Follow the

venting manufactures instructions on installation, cutting, de-burring, cementing, curing and supporting of the venting system.

This furnace can be vented with ULC S636 certified PVC material with a rating of 65°C or more.

The supplied PVC street elbows are certified for use within the vestibule. Use the approved transition cement certified by the ULC S636 venting supplier.

The optional Concentric Vent Termination Kits are available. Use the approved transition cement certified by the ULC S636 venting supplier.

The combustion air piping does not have flue gases traveling through it and may be installed with common ABS, PVC, or CPVC piping or fittings. The piping, fittings, primer and cement will need to be installed as per the manufactures instructions including cementing, cutting, curing and supporting the piping

11 - NON-DIRECT VENT FURNACE INSTALLATIONS (USING INDOOR COMBUSTION AIR)

The furnace, although designed as a direct vent type appliance, may be installed with the intake vent inside the structure.

WARNING



THIS FURNACE AND ANY OTHER FUEL BURNING APPLIANCE MUST BE PROVIDED WITH ENOUGH FRESH AIR FOR PROPER COMBUSTION AND VENTILATION OF THE FLUE GASES. MOST HOMES WILL REQUIRE THAT OUTSIDE AIR BE BROUGHT TO THE FURNACE AREA. FAILURE TO DO SO CAN CAUSE PERSONAL INJURY, OR DEATH FROM CARBON MONOXIDE POISONING.

Adequate provisions for combustion and ventilation air must be in accordance with CAN/CGA-B149 in Canada, and ANSI Z223.1 - 1992, section 5.3, "Air for Combustion and Ventilation," in the United States. Check with local authorities for any additional building codes bylaws or regulations.

CAUTION



Air for combustion and ventilation purposes must not originate from a corrosive atmosphere. Any furnace failure caused by corrosive elements is excluded from warranty coverage.

The following types of installation sites (but not limited to the following) will require OUTDOOR AIR for combustion because of chemical exposures:

- Commercial buildings
- Buildings with indoor swimming pools
- Furnaces installed in laundry rooms
- Furnaces in hobby or craft rooms
- Furnaces installed near chemical storage areas

Exposure to the following substances in the combustion air supply (but not limited to the following) will also require OUTDOOR AIR for combustion:

Aerosols, particularly CFC based or propelled aerosols

- Air fresheners
- "Airplane Glue" and similar adhesives and cements
- Ammonia, as commonly found in permanent wave solutions used in hair dressing salons
- Anti-static fabric softeners used in clothes dryers
- Carbon tetrachloride
- Chlorinated cleaners and waxes
- Chlorine and bromine based swimming pool chemicals
- De-icing salts or chemicals (rock salt, etc.)
- Dry cleaning fluids such as perchloroethylene
- Fumes from curing polyurethane and similar substances
- Halogen based refrigerants including R-12 and R-22
- Hydrochloric acid, muriatic acid and other acid based masonry washing and curing materials
- Printer's inks, paint removers, varnishes, varsol, toluene, etc.
- Water softener salt and chemicals

Combustion air must be free of acid forming chemicals such as sulphur, fluorine and chlorine. These elements are found in aerosol sprays, detergents, bleaches, cleaning solvents, air fresheners, paint and varnish removers, refrigerants, and many other commercial and household products. When burned in a gas flame, vapors from these products form acid compounds. Acid compounds increase the dew point temperature of the flue products and are highly corrosive after they condense.

12 - DETERMINING COMBUSTION AIR

CASE 1 - Furnace Located In An Unconfined Space

Unconfined space does not necessarily mean that ventilation will not have to be introduced from the outdoors, particularly in airtight homes. The minimum requirement for unconfined space is a volume of 50 cubic feet for each 1000 BTU/Hr for all fuel burning appliances located within the unconfined area.

If the amount of combustion and ventilation air is insufficient to properly operate the furnace and other fuel burning appliances within the unconfined area, it will be necessary to supply it from the outdoors based on the criteria used when calculating the air supply for a confined space.

NOTICE

NOTE: If planning to use the inside air in an unconfined space, remember to test for proper furnace operation (as well as other fuel burning appliances located within the unconfined space) with respect to adequate combustion and ventilation air with fireplace dampers open, clothes dryer running, bathroom exhaust fans on, kitchen range hood on, etc.

CASE 2 - Furnace Located In A Confined Space

A confined space, (any space smaller than the minimums discussed

12- DETERMINING COMBUSTION AIR

in Case 1), must have two air openings; one within 12" of the ceiling and the other within 12" of the floor. The air openings must be sized based on whether the combustion and ventilation air is being taken from indoors or outdoors, the method outdoor air (if used) is introduced, and taking into account any other fuel burning appliances in the confined space.

If sufficient indoor combustion and ventilation air is available for the furnace and all other fuel burning appliances, size each opening on the basis of one square inch of free area per 1000 BTU/Hr. (**Figure 4**)

NOTICE

NOTE: Be sure to consider all clothes dryers, bathroom fans, range hoods, etc., when making this calculation.

Figure 4 - Combustion/Dilution Air From Heated Inside Sources (Case 2)

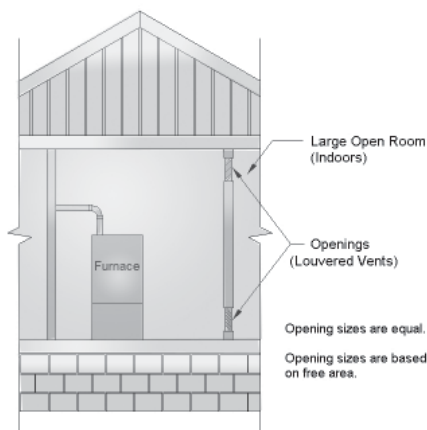

The minimum requirement for these openings is 100 square inches, even for the furnace models under 100,000 btu/hr.

NOTICE

NOTE: If using grilles to cover the two openings, factor in the free area of the grille. Typically, a sidewall grille will have a free area approximately 50% of its nominal size. Consequently, if the required opening is 10 x 10, it will have to be doubled if using a sidewall grille with 50% free area.

NOTICE

IMPORTANT: If an exhaust fan, fireplace, clothes dryer or any similar device is present in the indoor area from which the combustion and ventilation air will be drawn, negative pressure could be a problem if natural infiltration from the outdoors does not match the rate at which air is exhausted.

CASE 3 - Furnace Located In A Confined Space, Outdoor Air From Attic Or Crawl Space

In this circumstance, the free area of each of the two combustion and ventilation air openings is based on a minimum of 1 square inch per 4000 BTU/Hr. In this configuration, one opening can originate from the floor drawing combustion and ventilation air from the ventilated crawl space.

The other opening may communicate freely with a ventilated the attic. If using the attic air, ensure that the opening is ducted from the ceiling high enough to be above the insulation. The attic must be adequately vented with soffit vents or gable vents. (**Figure 5**)

Figure 5 - Outside Air For Combustion, Attic Or Crawl Space (Case 3)

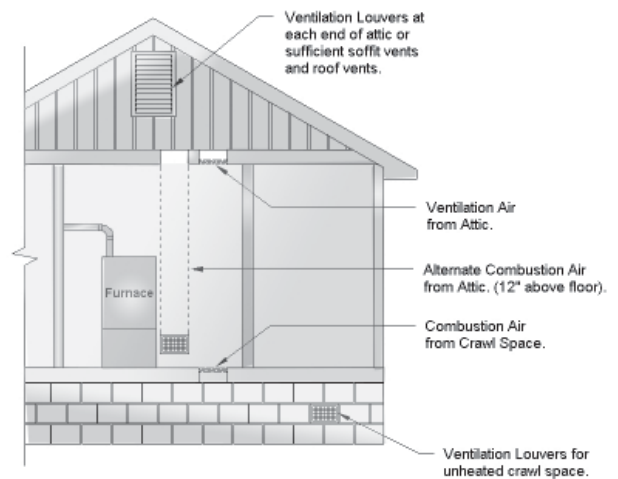

As an alternative to creating an opening in the floor to draw air from a crawl space, a duct may be dropped from the attic terminating 12" above the floor.

The following table (**Table 3**) shows minimum free areas and round pipe sizes when drawing combustion air vertically from the attic or crawl space for the furnace only. If other fuel burning appliances are present, their combustion air and ventilation air requirements must be added to those of the furnace.

TABLE 3 - VERTICAL AIR SUPPLY (CASE 3)

Model	Free Area Ea. Opening	Round Pipe Size
40	10 in. ²	4 in.
60	15 in. ²	5 in.
80	20 in. ²	6 in.
100	25 in. ²	6 in.
120	30 in. ²	7 in.

NOTICE

IMPORTANT: If the attic has an exhaust fan (power vent), it may create a negative pressure sufficiently large enough to prevent the attic from being an effective source of combustion and ventilation air. Powered attic fans do not customarily run during the heating season; however, some are controlled by a humidistat as well as a thermostat, which may allow some operation during the heating season. The choices are (a) use the direct vent option; (b) obtain outdoor air from elsewhere; or (c) interlock the attic exhaust fan with the furnace such that the two cannot operate simultaneously.

Figure 6 - Outdoor Air For Combustion, Horizontal (Case 4)

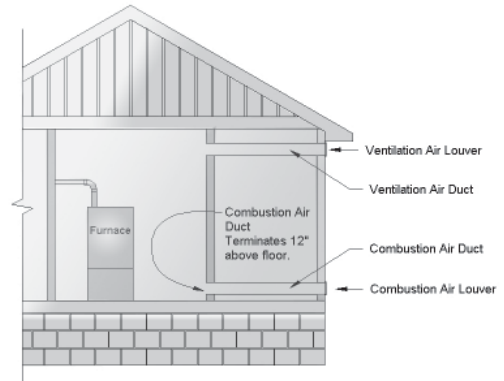

CASE 4: Furnace Located In A Confined Space, Outdoor Air Ducted Horizontally

Similar to Case 3, outdoor air for combustion and ventilation may be drawn through horizontal ducting. The free area for each opening is calculated on the basis of a minimum of 1 square inch per 2000 BTU/Hr input.

The following table (Table 4) shows minimum free areas and round pipe sizes when drawing combustion air horizontally from the outdoors for the furnace only. If other fuel burning appliances are present, their combustion air and ventilation air requirements must be added to those of the furnace.

TABLE 4 - HORIZONTAL AIR SUPPLY (CASE 4)

Model	Free Area Ea. Opening	Round Pipe Size
40	20 in. ²	6 in.
60	30 in. ²	7 in.
80	40 in. ²	8 in.
100	50 in. ²	8 in.
120	60 in. ²	9 in.

CASE 5: Furnace Located In A Confined space, Outdoor Air Ducted with Single Opening (US Only)

One permanent opening, commencing within 12 in. (300 mm) of the top of the enclosure, shall be provided. The appliance shall have clearances of at least 1 in. (25 mm) from the sides and back and 6 in. (150 mm) from the front of the appliance. The opening shall directly communicate with the outdoors or shall communicate through a vertical or horizontal duct to the outdoors or spaces that freely communicate with the outdoors and shall have a minimum free area of the following:

- 1 in²/3000 BTU/hr (700 mm² per kW) of the total input rating of all appliances located in the enclosure, and
- Not less than the sum of the areas of all vent connectors in that space.

Connection To Furnace Non-Direct Vent

When using indoor air or the non-direct vent configuration, the combustion air inlet to the furnace must be protected from blockage. Use a double elbow arrangement if supplying combustion air through the top, or a downward pointing single elbow if supplying combustion air through the side. (Figure 7)

NOTICE

IMPORTANT: If grilles are used on the outside wall, they must be sized properly. Most sidewall grilles have only 50% free area. In the case of a unit with 100,000 Btuh input, which requires a pair of 8" round pipes to obtain sufficient combustion and ventilation air, the duct could be an equivalent rectangular duct; 8" x 7" for example. Based on 50% free area for the inlet grilles, the actual grille size would have to be 14" x 8" or its equivalent. A transition may be used to reduce to the smaller duct size if necessary.

Figure 7- Non-Direct Combustion Air Inlet

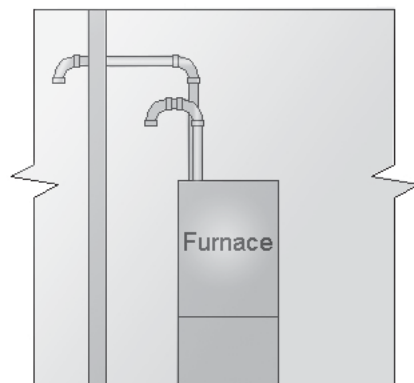

NOTICE

IMPORTANT: The outdoor grilles must be installed in a location where they will not be obstructed in any manner.

CAUTION



Failure to follow all venting guidelines may result in erratic furnace operation, freeze-up of the exhaust air piping, or sooting of the furnace.

WARNING



READ AND FOLLOW ALL INSTRUCTIONS IN THIS SECTION. FAILURE TO PROPERLY VENT THIS FURNACE CAN CAUSE CARBON MONOXIDE POISONING OR AN EXPLOSION OR FIRE RESULTING IN PROPERTY DAMAGE, PERSONAL INJURY OR LOSS OF LIFE.

NOTICE

NOTE: Combustion air intake and exhaust termination should be inspected periodically to ensure they are clear of obstructions. i.e. vegetation, debris, snow, etc.

NOTICE

NOTE: Accumulation of snow around the combustion air intake and exhaust termination may have negative effects on appliance operation and/or performance. Snow accumulation should be considered when locating combustion air intake and exhaust terminations.

- Venting may be vertical or horizontal.
- Minimum vent length - 25 total equivalent feet. (See Table 5 - Direct and Non-Direct Vent Lengths)
- Horizontal piping must slope back towards the furnace at a minimum rate of 1/4" to the foot, so that condensate drains towards the furnace.
- Horizontal runs must be supported at least every 3 feet. Horizontal sections must not dip or sag.
- All vent runs through unconditioned space where freezing might occur should be insulated with 1" thick, medium density, foil-faced Fiberglass insulation. An equivalent "arm-a-flex" or "rub-a-tex" may also be used as long as there is no heat tape applied to the vent pipe. For horizontal runs where water may collect, wrap the vent pipe with self regulating 3 or 5 watt heat tape. The heat tape must be CSA, UL, or ULC listed and installed per the manufacturer's instructions.
- DO NOT COMMON VENT WITH ANY OTHER APPLIANCE.

- If venting vertically, do not vent up a chimney serving another appliance or install in a chase with a metal or high temperature plastic pipe from another gas or fuel burning appliance unless the required clearances to combustibles can be maintained between the PVC pipe and other pipes.

All exhaust piping must be installed in accordance with CAN/CGA-B149 in Canada; the latest edition of National Fuel Gas Code, NFPA 54 / ANSI Z223.1 in the United States, as well as in accordance with local codes.

Size the combustion air and exhaust piping in accordance with **Table 5**. When calculating allowable vent lengths, be sure to count all termination fittings in addition to counting the concentric vent as a straight pipe.

Take the building orientation and the presence of other buildings or other nearby structures into consideration when planning the venting system location. Certain external structures could create air turbulence around the vent termination leading to downdrafts and similar venting problems. In windy and hill locations, roof venting may improve operations. Maximum venting length is based on 30 mph winds, areas where higher gusts are dominant it is suggest to shorten the horizontal vent length.

The vent and combustion air intake shall be installed so that both are located in the same wind pressure zone.

WARNING



DO NOT CONNECT FURNACE TO A CHIMNEY OR FLUE SERVING OTHER APPLIANCES OR A SOLID FUEL BURNING APPLIANCE

Vent Termination

Horizontal vents should pass through the exterior wall. **Figure 8** shows a standard horizontal vent detail. Terminate the vent approximately 8" or more from the wall.

Figure 8 - Standard (Straight) Horizontal Vent Detail

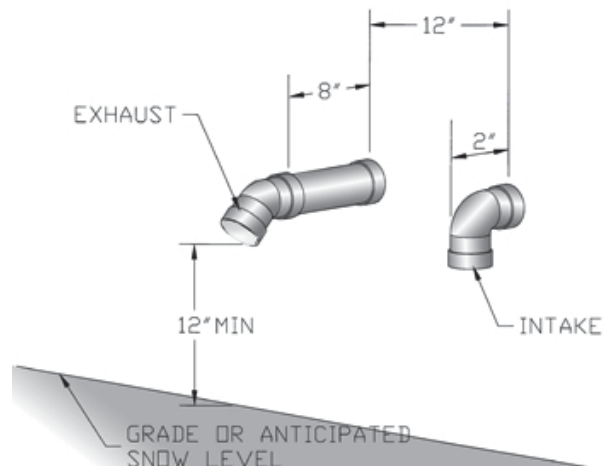

13 - VENTING GUIDELINES

If it is not possible to obtain proper clearance to grade by a straight out configuration, the termination may be raised by the use of a pair of 90° elbows. (**Figure 9**, Exhaust Detail Only)

NOTICE

NOTE: Length of pipe and elbows count toward maximum allowable vent length as shown in **Table 5** (below).

TABLE 5 - DIRECT AND NON-DIRECT VENT LENGTHS

MAXIMUM ALLOWABLE LENGTH OF EXHAUST OR INTAKE. MINIMUM VENT LENGTH - 25 TOTAL EQUIVALENT FEET.

MODEL	PIPE SIZE	NUMBER OF 90° ELBOWS							NOTES
		0	1	2	3	4	5	6	
40	1½	50	45	40	35	30	25	20	<ol style="list-style-type: none"> 1. Count concentric vent fitting as straight pipe. 2. Use medium or long sweep elbows where possible. 3. One 90° elbow is equivalent to two 45° elbows. 4. For direct vent, the listed lengths are allowed for each vent (intake and exhaust). 5. For non-direct vent, the listed lengths are allowed for exhaust. The intake should have a 1½" or 2" snorkel intake fitting. (Figure 7) 6. Include the 2 vestibule elbows when calculating total vent length for all models.
	2	100	95	90	85	80	75	70	
60	1½	25	20	15	10	5	-	-	
	2	75	70	65	60	55	50	45	
	3	100	95	90	85	80	75	70	
80	2	50	45	40	35	30	25	20	
	3	100	95	90	85	80	75	70	
100	2	50	45	40	35	30	25	20	
	3	100	95	90	85	80	75	70	
120	3	100	95	90	85	80	75	70	

When 1½" or 3" pipe is used, exit the cabinet with 2" pipe. Reduce or increase immediately after exiting the cabinet making provisions to secure the vent bracket between cabinet and fitting.
Use of a concentric termination reduces the allowable length by 5 feet from lengths shown in this table

Figure 9 - Periscoped Vent Detail

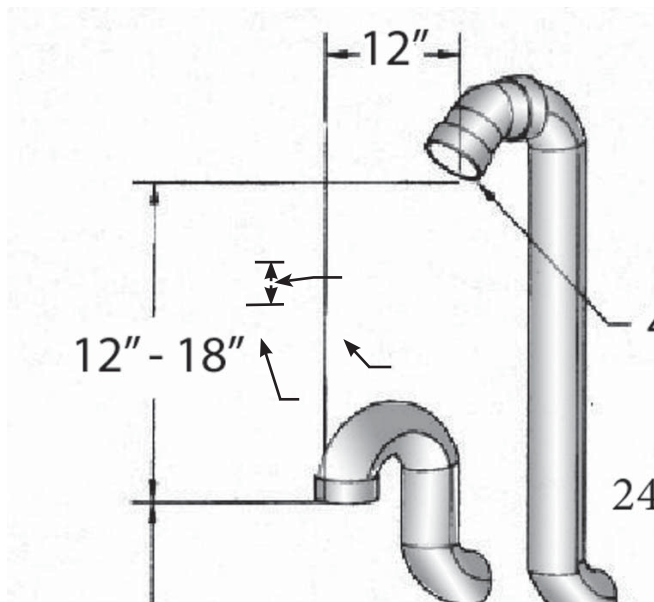
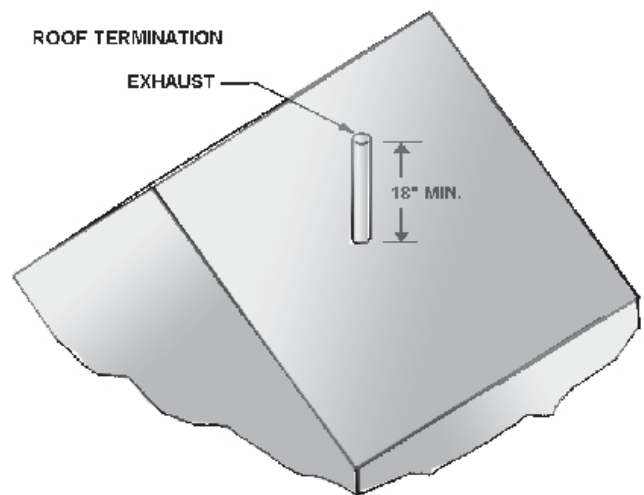

Figure 10 - Vertical Venting



The venting system must stay consistent in regards to pipe diameter through out the entire vent length. The vent may also terminate in a vertical venting configuration through the roof. No termination fitting is required. **(Figure 10)**

The exhaust pipe extending through the roof must extend 18" above the highest point where it extends through the roof, surface and above any obstruction within an 18" horizontal distance. **(Figure 10)**

Exterior vent pipe greater than 24" should be insulated with ½" insulation to prevent moisture from freezing within the pipe and accumulating.

Size the exhaust pipe as specified in **Table 5** - Direct and Non-Direct Vent Lengths. This table lists the maximum allowable length of pipe with respect to the number of 90° elbows used. For the purposes of this calculation, one 90° elbow is equivalent to two 45° elbows.

Avoid locating the termination in locations where dripping condensate may cause problems such as sidewalks, patios, above planters, near windows where exhaust gases may cause fogging, etc. Avoid locating the termination too close to shrubs and other vegetation. The condensate may stunt or kill them.

CAUTION



Moisture in the flue gases condenses as it leaves the termination. This moisture can freeze on exterior walls, on soffits, and other nearby objects. Some discoloration is to be expected; however, improper location or installation can cause structural or exterior finish damage to the building.

Caulk all cracks, seams or joints within a 6 foot radius of the termination.

Do not terminate under a deck unless there is adequate clearance to prevent damage from the flue gases. A termination may be located at the end of a patio deck. Piping running beneath the deck must be suitably insulated and suspended in a manner to prevent condensate from collecting and freezing.

Do not locate the termination on the side of the building facing the prevailing winter winds.

In Canada

In addition to the general guidelines, in Canada, the non-direct vent exhaust shall not terminate:

- Directly above a paved sidewalk or paved driveway which is located between two single-family dwellings and serves both dwellings;
- Less than 7 feet above a paved sidewalk or paved driveway located on public property;
- Within 6 feet of a mechanical air supply inlet to any building;
- Above a meter/regulator assembly within 3 feet horizontally of the center line of the regulator;
- Within 6 feet of any service regulator vent outlet;
- Less than 12" above grade level or anticipated snow level;
- Within 12" of any door, window, or non-mechanical air supply inlet to any building;
- Within 12" of the combustion air inlet of any other appliance;
- Underneath a veranda, porch or deck, unless (a) the veranda, porch or deck is fully open on a minimum of two sides beneath the floor, and (b) the distance between the top of the vent termination and the underside of the veranda, porch or deck is greater than 12".

In The U.S.A.

In addition to the general guidelines, in the United States, the non-direct vent exhaust shall be installed in accordance with the following:

- The clearance from the bottom of the termination to grade shall be 12".
- The vent shall not terminate over public walkways or over an area where condensate or vapor could create a nuisance or hazard.
- The vent termination shall be installed 4 feet below, 4 feet horizontally from, or 1 foot above any door, window, soffit, under eave vent or gravity air inlet to the building.
- The vent termination shall have a minimum horizontal clearance of 3 feet from electric meters, gas meters, regulators and relief equipment.
- Locate the vent termination 3 feet above any forced air inlet located within 10 feet. Any fresh air or make-up air inlet, such as for a dryer or furnace area is considered a forced air inlet.

The vent termination should be located no fewer than 6 feet from an inside corner formed by two exterior walls; a 10 foot distance is recommended.

Recommended clearance from overhangs is a minimum of 1 foot vertically for each foot horizontally up to 6 feet.

Furnace Venting Installations

WARNING



READ AND FOLLOW ALL INSTRUCTIONS IN THIS SECTION. FAILURE TO PROPERLY VENT THIS FURNACE CAN CAUSE CARBON MONOXIDE POISONING OR AN EXPLOSION OR FIRE RESULTING IN PROPERTY DAMAGE, PERSONAL INJURY OR LOSS OF LIFE.

Non-Direct Vent Installation (Using Indoor Combustion Air)

Non-direct vent installations require only a vent pipe. This may be desirable when using outdoor combustion air is not practical.

- Provisions are not made for routing of combustion air;
- The outdoor environment may contain contaminants undesirable for combustion.

Direct Vent Installation (Using Outdoor Combustion Air)

The direct vent configuration is the preferred installation method. The primary advantages are:

- Dedicated combustion air and vent piping eliminates the need to use already heated air for combustion purposes;
- The probability of corrosive contaminants being present in the combustion air is greatly reduced;
- The direct vent configuration is unaffected by any other appliances, exhaust fans, or other devices that tend to create negative pressure conditions while operating.

- No vents for combustion and ventilation air are required in confined spaces

Combustion Air

This furnace is certified as a Category IV Type FSP Non-Direct and Direct Vent Furnace. When installed as a direct vent furnace, all combustion air is supplied from the outdoors via the plastic piping system. All components are field supplied except for the adapter used to connect the piping to the furnace.

The combustion air piping, like the exhaust piping, must be air tight throughout the system. The adapter joining the combustion air to the furnace is supplied with a gasket to maintain the seal.

NOTICE

IMPORTANT: The supplied adapter is made of PVC. If planning to use ABS pipe, use an all-purpose cleaner and ABS to PVC transition cement. If planning to use CPVC pipe, use an all-purpose cleaner, a clear or purple primer and all-purpose cement approved for the purpose.

Additional information about cleaners, primers, solvents and cements may be obtained from their manufacturers.

NOTICE

IMPORTANT: If the furnace is to be installed in the vicinity of other fuel burning appliances, adequate combustion air must be available for the non-direct vent appliances. See Section 12 of this manual, "Determining Combustion Air."

14 - TERMINATIONS

Combustion Air

HORIZONTAL - The combustion air termination is a 1½" or 2" medium or long sweep 90° elbow pointing downward to prevent rain from readily entering the combustion air intake piping. An intake screening is optional; however, unless there is a compelling reason to use one, the screen may actually encourage the formation of rime ice, which could cause the intake to become blocked in certain weather conditions.

If the required clearance to grade cannot be obtained with the "straight through" configuration, the combustion air intake pipe may be "periscoped" up to 24" to gain extra height (**Figure 9**)

VERTICAL - The combustion air termination is a pair of 2" medium or long sweep 90° elbow pointing downward to prevent rain from entering the combustion air intake piping. The termination inlet must be positioned within 3" of the companion exhaust piping.

The combustion air inlet must be located a minimum of 12" above grade, and 12" below the exhaust outlet. (**Figure 11**)

Figure 11 - Standard Vertical Venting Detail

ROOF TERMINATION

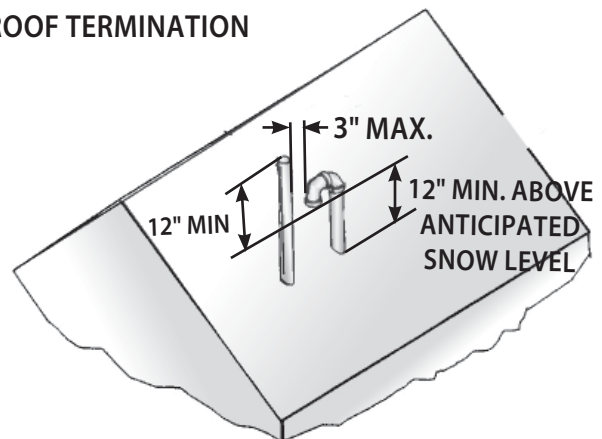

Exhaust

HORIZONTAL - The exhaust termination is normally a 45° elbow or a medium or long sweep 90° elbow pointing within 45° of the downward position, away from the combustion air intake termination.

If the required clearance to grade cannot be obtained with the “straight through” configuration, the exhaust pipe may be “periscoped” up to 24” to gain extra height. **(Figure 9)** In this case, the flue gases may be expelled horizontally. Use the same size pipe as the interior run and count the fittings and length as part of the total vent length.

If winter prevailing wind conditions are variable and likely to occasionally blow flue gases back in on the combustion air intake, the exhaust termination may be raised 18-24” above the combustion air intake termination to take advantage of the natural buoyancy of the flue gases to help prevent re-circulation of the exhaust. **(Figure 9)**

VERTICAL - No termination fitting is required if venting vertically through a roof. The end of the exhaust pipe must be 12” higher than the entrance of the combustion air intake termination. **(Figure 11)**

The exhaust pipe extending through the roof must extend a minimum of 18” above any obstruction within an 18” horizontal distance.

Concentric Venting Kit

Concentric venting termination kits may be used for this series furnace. They provide a means of obtaining combustion air and exhausting products of combustion utilizing a single penetration through the exterior wall. This can be useful when there is limited wall space available. Kits are available in 2” and 3” sizes. If venting the 60000 Btuh model with 1½” vent material, and a concentric vent kit is necessary, an increase coupling may be used to connect to the 2” concentric venting kit. Read the instructions supplied with the kit for additional installation instructions and details.

Concentric Vent Termination Installation Instructions

Follow the concentric vent termination manufacturer's instructions for installation of the concentric vent termination kit. These instructions can be found by contacting the furnace manufacturer. Furnace manufacturer contact information is found on the front cover of this installation manual and operating instructions.

Location

Avoid locating the terminations where the flue gas could become stagnant and allow recirculation into the combustion air intake.

Avoid locating the termination in locations where dripping condensate may cause problems such as sidewalks, patios, above planters, near windows where exhaust gases may cause fogging, etc.

Avoid locating the termination too close to shrubs and other vegetation. The condensate may stunt or kill them.

Caulk all cracks, seams or joints within a 6 foot radius of the termination.

Do not terminate under a deck unless there is adequate clearance to prevent damage from the flue gases. A termination may be located at the end of a patio deck. Piping running beneath the deck must be suitably insulated and suspended in a manner to prevent condensate from collecting and freezing.

Do not locate the termination on the side of the building facing the prevailing winter winds.

CAUTION



Improper location or installation can result in structural damage to the building, damage to the exterior finish of the building, or may allow recirculation or freezing of the flue gases onto or into the combustion air intake.

Moisture in the flue gases condenses as it leaves the terminations. This moisture can freeze on exterior walls, soffits, and other nearby objects. Some discoloration is to be expected.

The vent termination should be located no fewer than 6 feet from an inside corner formed by two exterior walls. A 10 foot distance is recommended.

Recommended clearance for overhangs is a minimum of 1 foot vertically for each foot horizontally up to 6 feet.

Any adjacent painted surfaces should be in good condition; no cracks, peeling paint, etc. If wooden surfaces that may be periodically exposed to flue gases are present, consider treating with a sealer such as Thompson's Water Seal®. Additional information about sealers may be obtained from the Thompson's web site at www.thompsonsonline.com.

Multiple Venting

NOTICE

IMPORTANT: When installing multiple furnaces in close proximity, each requires dedicated combustion air and exhaust venting.

COMMON VENTING IS PROHIBITED!!

If two of these furnaces are to be installed in close proximity, the combustion air intake and exhaust terminations may be installed as shown in **Figures 12 and 13**.

Figure 12 - Multiple Venting (Standard Horizontal)

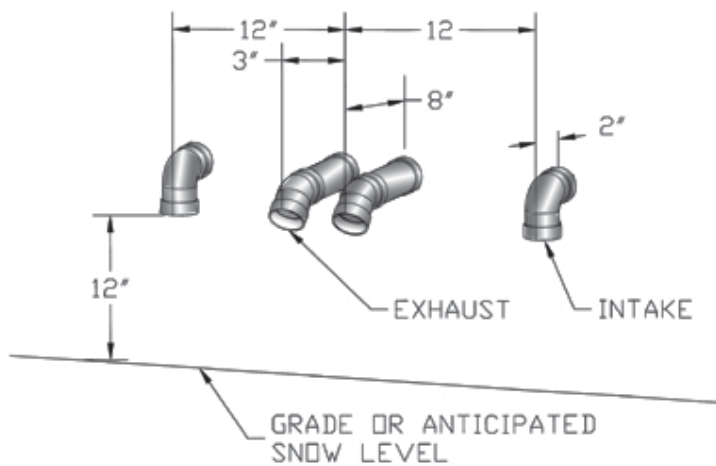
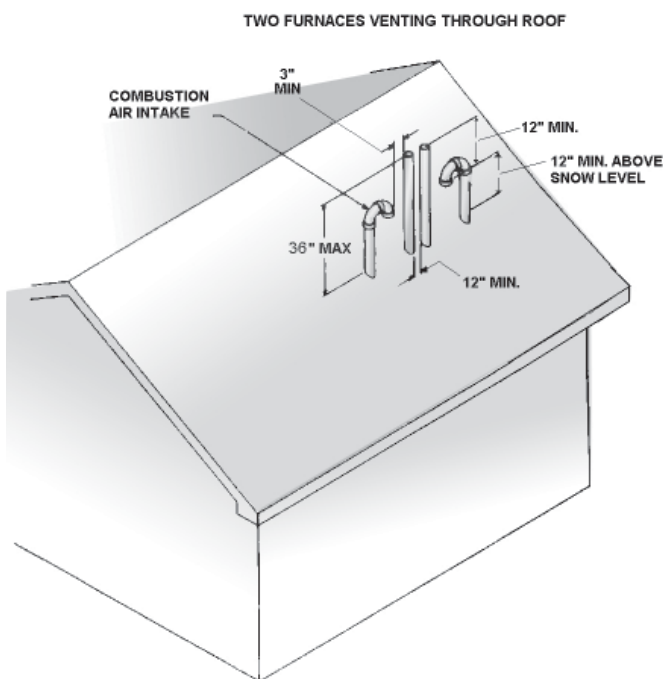

Figure 13 - Multiple Venting (Standard Vertical)



If more than two furnaces are being installed in close proximity, each additional combustion air intake and exhaust termination set shall not terminate less than 12 in (300mm) apart. Note: Canadian installations of 120000 Btuh require 3 ft (900mm). This is an exception to the 10 foot requirement mentioned in the "Location" section on the previous page.

WARNING



Recirculation of flue gases may occur causing the intake pipe to freeze shut during cold weather operation if the venting system is not installed per these guidelines.

In Canada

In addition to the general guidelines, both non-direct and direct vent exhaust shall not terminate:

- Directly above a paved sidewalk or paved driveway which is located between two single-family dwellings and serves both dwellings;
- Less than 7 feet above a paved sidewalk or paved driveway located on public property;
- Within 6 feet of a mechanical air supply inlet to any building;
- Above a meter/regulator assembly within 3 feet horizontally of the center line of the regulator;
- Within 6 feet of any service regulator vent outlet;
- Less than 12" above grade level or anticipated snow level;
- Within 12" of any door, window, or non-mechanical air supply inlet to any building;
- Within 12" of the combustion air inlet of any other appliance;
- Underneath a veranda, porch or deck, unless (a) the veranda, porch or deck is fully open on a minimum of two sides beneath the floor, and (b) the distance between the top of the vent termination and the underside of the veranda, porch or deck is greater than 12".
- Refer to **Figures 16A and 16B** for termination clearances.

In The U.S.A.

In addition to the general guidelines, in the United States, both non-direct and direct vent exhaust shall be installed in accordance with the following:

- The clearance from the bottom of the termination to grade shall be 12".
- The vent shall not terminate over public walkways or over an area where condensate or vapor could create a nuisance or hazard.
- The vent termination shall be installed at least 1 foot from any opening through which flue gases could enter a building.

14 - TERMINATIONS

- The vent termination shall have a minimum horizontal clearance of 3 feet from electric meters, gas meters, regulators and relief equipment.
- Locate the vent termination 3 feet horizontally from the vent of any side wall vented fuel gas appliance or electric clothes dryer, except in the case where two or more of these furnaces are multi-vented. (See “Multiple Venting”)
- Refer to **Figures 16A and 16B** for termination clearances.

Furnace Connection

NOTICE

IMPORTANT: Clean and de-burr all pipe cuts. The shavings must not be allowed to block the exhaust, combustion air inlet or condensate drain lines.

NOTICE

IMPORTANT: If the pipe and fittings are to be other than PVC, use the proper cleaner, primer and cement for the dissimilar materials.

WARNING



There must not be any openings between the blower division panel and the combustion compartment. The blower compartment is under greater suction than the combustion compartment and can pull combustion air from the burners and cause incomplete combustion and erratic furnace operation.

WARNING



The vent must be clamped to the furnace panel using the gasket and clamp provided. The intake must use the threaded PVC connector with the gasket and lock nut.

Routing Options

The furnace can be installed in any of four positions. **Figures 17-20** on the following pages show the four positions. The installer must consider the following services: gas pipe, electrical power, drain trap, intake and exhaust vents. Also consider the air conditioning connections and drain, access to filter(s) and access to furnace and a/c for repair. Drains and traps of furnaces installed in spaces subjected to freezing temperature must also be protected against freezing.

The vent must be clamped to the exterior panel(s) with the clamp provided. Place the gasket between the clamp and the side panel. Tighten clamp and fasten in place using the three screws provided. The clamp should secure the vent pipe to prevent internal damage if

the vent pipe is tampered with. (See **Figure 14**)

The combustion air inlet fitting is a 2” PVC Socket to Pipe Thread adapter. Choose the intake location and open the appropriate knock out. Install the adapter to the exterior panel using the gasket (on the outside of the panel and the locknut on the inside of the panel.

Figure 14 -Vent Clamp and Gasket

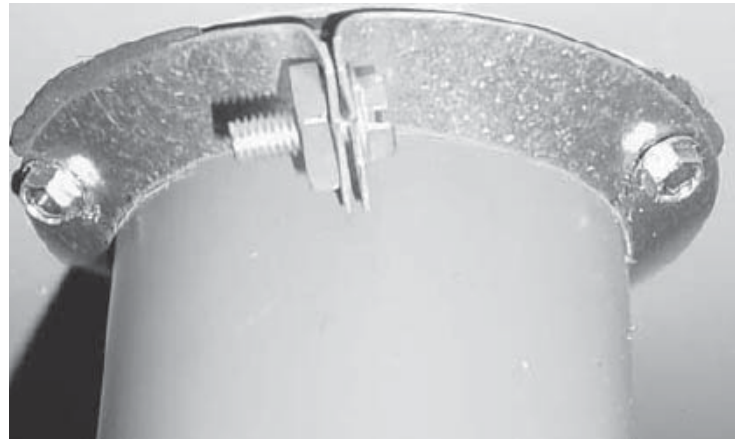

NOTICE

IMPORTANT: Keep pressure switch hose above heat exchanger drain.

Figure 15- Pressure Switch Positioning

ORIENTATION		ROTATE INDUCER	RECOMMEND MOUNTING
FURNACE	FLUE		
Down	Left	Y	B or G
Down	Right	N	G
Up	Left	N	A or E
Up	Right	Y	G
Up	Vertical	N	A or E
Horz. Left	Vertical	Y	E
Horz. Right	Vertical	N	A or E
Horz. Right	Right	N	A or E

Venting Installation Instructions

1. Remove 4 inducer screws
2. Disconnect inducer wire connections.
3. Remove pressure switch hose.
4. Remove pressure switch if applicable.
5. Remove inducer.
6. Reverse the clamps on the rubber drain coupling so the screws are accessible if necessary. (Do not reverse the drain coupling.) Confirm that directional arrows on drain coupling point away from inducer.
7. Remove the appropriate knock out.
8. Reinstall the inducer in the correct orientation with 4 screws removed in step 1.
9. Reinstall the pressure switch so that the switch and hose is above the heat exchanger drain. See pressure switch recommended mounting **Figure 15**.
10. Complete the venting as installation requires. If exiting the top panel, use two street elbows to route the vent. One elbow secured to the inducer, will angle toward the front of cabinet with the second nested inside directed towards the top panel. The 100,000 BTUH input unit will require an extension between the inducer and the first elbow. If exiting the side panels the pipe can be routed straight outside the cabinet. The pipe exiting the cabinet in any installation should be long enough to install the vent clamp on the outside of the cabinet.
11. Rotate the drain coupling so the drain holes are angled downward and tighten coupling bands.
12. Tighten the vent clamp and secure in place using three screws provided.

Always support the vent and intake to the floor joists or rafters to avoid sagging and possible fatigue of venting materials. This ensures proper drainage and prevents spilling of the products of combustion into the building.

The blower compartment should be complete isolated from the burner compartment. In tight rooms with other combustion devices, the blower compartment must be completely isolated from the room. The combustion compartment must also be completely isolate from the room (unless indirect vent). Inspect unused knockouts to ensure that they are completely sealed.. Use caulking on the inside of the cabinet to seal any holes. Insure that the combustion door gasket is in good condition.

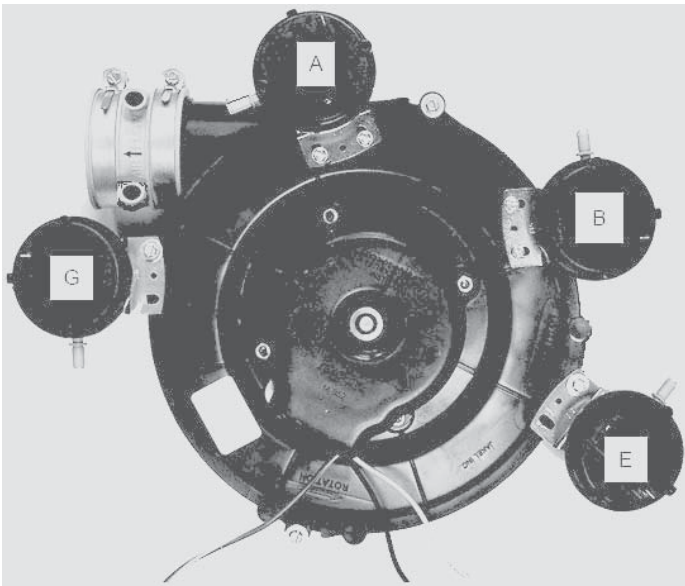

EXAMPLE: In a Horizontal Right/Vertical application (not shown), when the furnace is horizontal, room air is exiting from the right side of furnace, and the flue is vertical (exiting from the left side panel in an upflow position), the pressure switch should be mounted at location A or E.

Figure 16A & 16B- Direct Vent & Non-Direct Termination Clearances

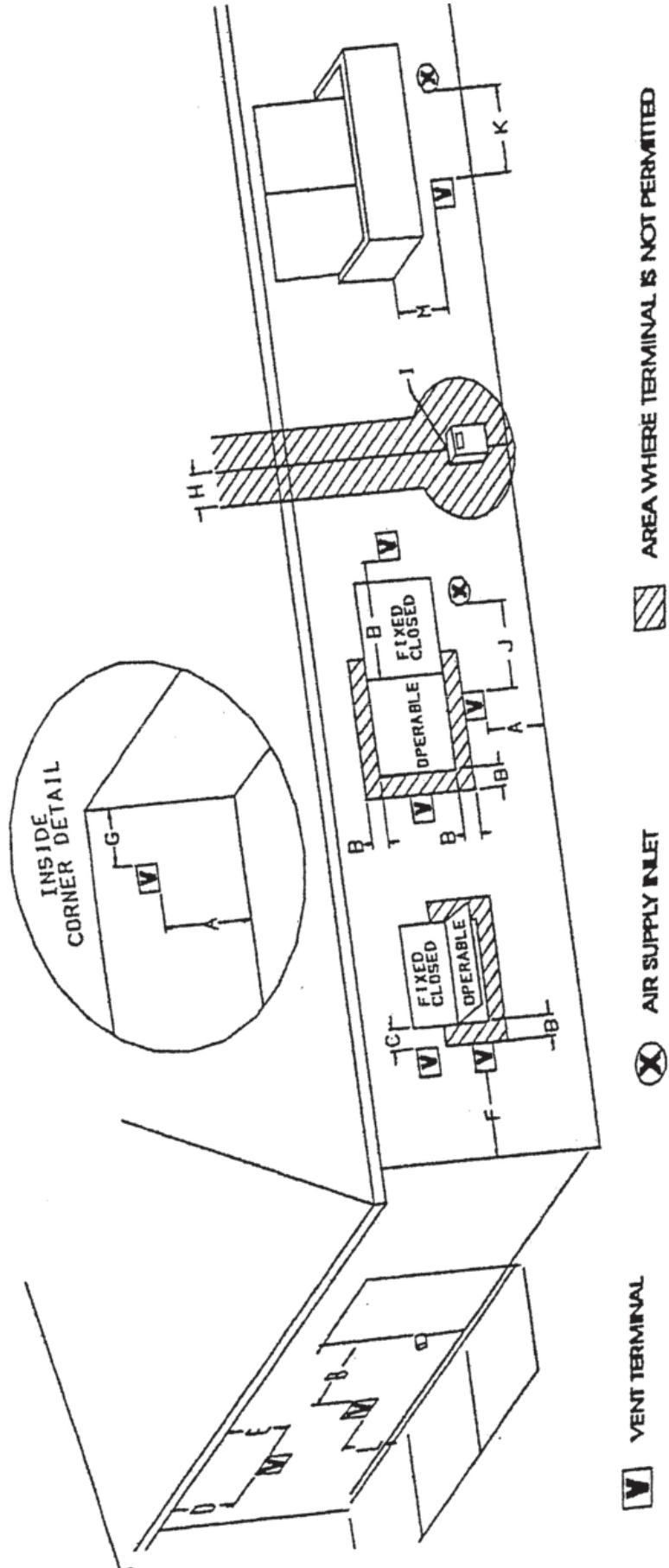

Figure 16A - Direct Vent Termination Clearances

DIRECT VENT TERMINATION CLEARANCES		
Clearance	Canadian Installations - 1	US Installations - 2
A = Clearance above grade, veranda, porch, deck, or balcony	12 inches (30cm)	12 inches (30cm)
B = Clearance to window or door that may be opened	6 inches (15cm) for appliances ≤ 10,000 Btuh (3kW), 12 inches (30 cm) for appliances > 10,000 Btuh (3kW) and ≤ 100,000 Btuh (30kW), 36 inches (91cm) for appliances > 1000,000 Btuh (30kW)	6 inches (15cm) for appliances ≤ 10,000 Btuh (3kW), 9 inches (23 cm) for appliances > 10,000 Btuh (3kW) and ≤ 50,000 Btuh (15kW), 12 inches (30 cm) for appliances > 50,000 Btuh (15kW)
C = Clearance to permanently closed window	*	*
D = Vertical clearance to ventilated soffit located above the termination within a horizontal distance of 2 feet (61 cm) from the center line of the termination	*	*
E = Clearance to unventilated soffit	*	*
F = Clearance to outside corner	*	*
G = Clearance to inside corner	*	*
H = Clearance to each side of center line extended above meter/regulator assembly	3 feet (91 cm) within a height 15 feet (4.5 m) above the meter/regulator.	*
I = Clearance to service regulator vent outlet	3 feet (91 cm)	*
J = Clearance to non-mechanical air supply inlet to building or the combustion air inlet to any other appliance	6 inches (15 cm) for appliances ≤ 10,000 Btuh (3kW), 12 inches (30 cm) for appliances > 10,000 Btuh (3kW) and ≤ 100,000 Btuh (30 kW), 36 inches (91 cm) for appliances > 100,000 Btuh (30 kW)	6 inches (15 cm) for appliances ≤ 10,000 Btuh (3kW), 9 inches (23 cm) for appliances > 10,000 Btuh (3kW) and ≤ 50,000 Btuh (15 kW), 12 inches (30 cm) for appliances > 50,000 Btuh (15 kW)
K = Clearance to mechanical air supply inlet	6 feet (1.83 cm)	3 feet (91 cm) above if within 10 feet (3m) horizontally
L = Clearance above paved sidewalk or paved driveway located on public property	7 feet (2.13m) +	*
M = Clearance under veranda, porch, deck or balcony	12 inches (30 cm) ++	*
<p>1 In accordance with the current CSA B149.1.1, Natural Gas and Propane Installation Code</p> <p>2 In accordance with the current ANSI Z223.1/NFPA 54, National Fuel Gas Code</p> <p>+ A vent shall not terminate directly above a sidewalk or paved driveway that is located between two single family dwellings and serves both dwellings.</p> <p>++ Permitted only if veranda, porch, deck or balcony is fully open on a minimum of two sides beneath the floor</p> <p>* For clearances not specified in ANSI Z223.1/NFPA 54 or CSA B149.1, the following statement shall be included: "Clearance in accordance with local installation codes and the requirements of the gas supplier and the manufacturer's installation instructions."</p>		

Figure 16B - Non-Direct Vent Termination Clearances

NON - DIRECT VENT TERMINATION CLEARANCES		
Clearance	Canadian Installations - 1	US Installations - 2
A = Clearance above grade, veranda, porch, deck, or balcony	12 inches (30cm)	12 inches (30cm)
B = Clearance to window or door that may be opened	6 inches (15cm) for appliances ≤ 10,000 Btuh (3kW), 12 inches (30 cm) for appliances > 10,000 Btuh (3kW) and ≤ 100,000 Btuh (30kW), 36 inches (91cm) for appliances > 1000,000 Btuh (30kW)	4 feet (1.2 cm) below or to side of opening; 1 foot (300 m) above opening
C = Clearance to permanently closed window	*	*
D = Vertical clearance to ventilated soffit located above the termination within a horizontal distance of 2 feet (61 cm) from the center line of the termination	*	*
E = Clearance to unventilated soffit	*	*
F = Clearance to outside corner	*	*
G = Clearance to inside corner	*	*
H = Clearance to each side of center line extended above meter/regulator assembly	3 feet (91 cm) within a height 15 feet (4.5 m) above the meter/regulator.	*
I = Clearance to service regulator vent outlet	3 feet (91 cm)	*
J = Clearance to non-mechanical air supply inlet to building or the combustion air inlet to any other appliance	6 inches (15 cm) for appliances ≤ 10,000 Btuh (3kW), 12 inches (30 cm) for appliances > 10,000 Btuh (3kW) and ≤ 100,000 Btuh (30 kW), 36 inches (91 cm) for appliances > 100,000 Btuh (30 kW)	4 feet (1.2 cm) below or to side of opening; 1 foot (300 m) above opening
K = Clearance to mechanical air supply inlet	6 feet (1.83 cm)	3 feet (91 cm) above if within 10 feet (3m) horizontally
L = Clearance above paved sidewalk or paved driveway located on public property	7 feet (2.13m) +	7 feet (2.13cm)
M = Clearance under veranda, porch, deck or balcony	12 inches (30 cm) ++	*
<p>1 In accordance with the current CSA B149.1.1, Natural Gas and Propane Installation Code</p> <p>2 In accordance with the current ANSI Z223.1/NFPA 54, National Fuel Gas Code</p> <p>+ A vent shall not terminate directly above a sidewalk or paved driveway that is located between two single family dwellings and serves both dwellings.</p> <p>++ Permitted only if veranda, porch, deck or balcony is fully open on a minimum of two sides beneath the floor</p> <p>* For clearances not specified in ANSI Z223.1/NFPA 54 or CSA B149.1, the following statement shall be included: "Clearance in accordance with local installation codes and the requirements of the gas supplier and the manufacturer's installation instructions."</p>		

Figure 17- Upflow Option

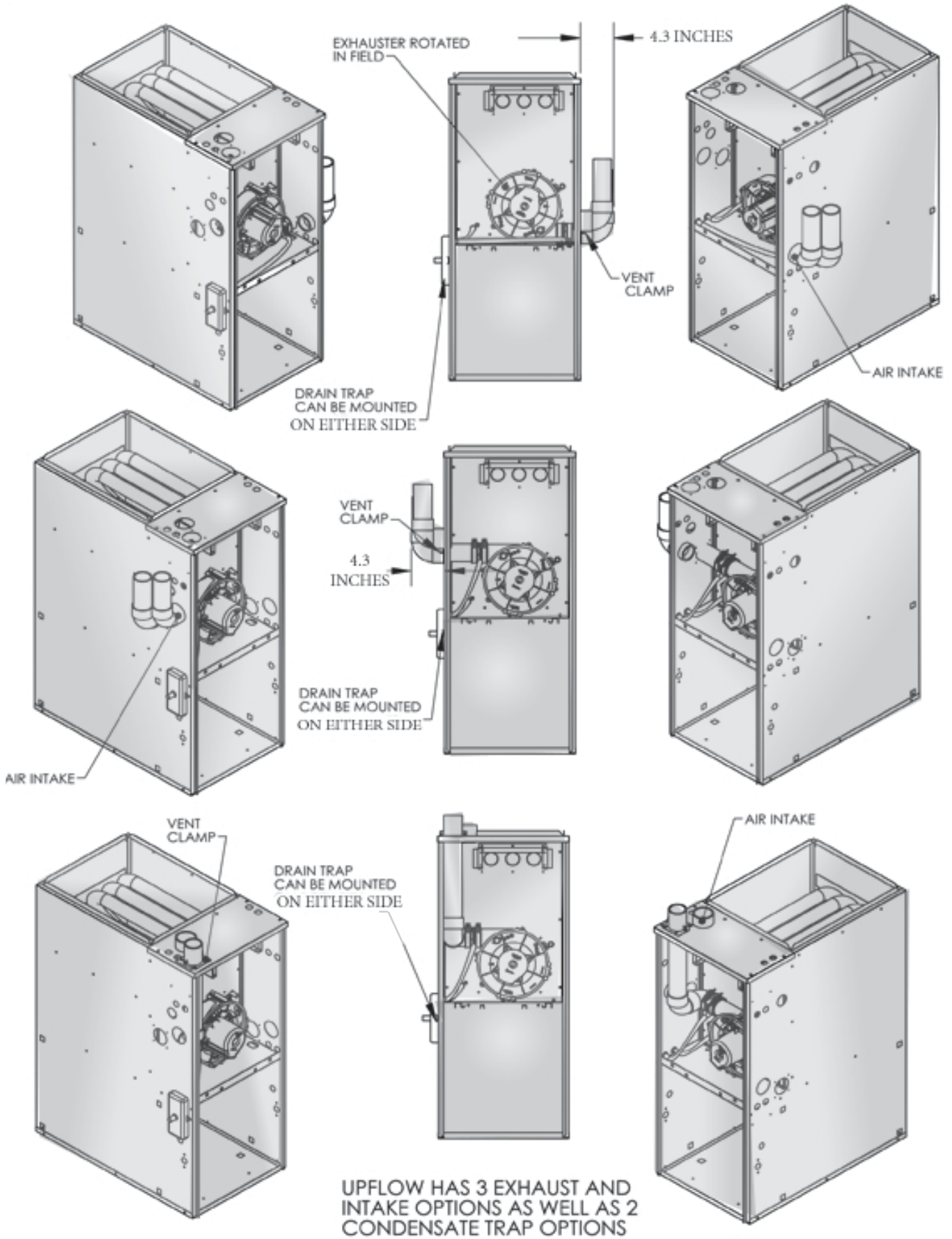

Figure 18 - Horizontal Right Option

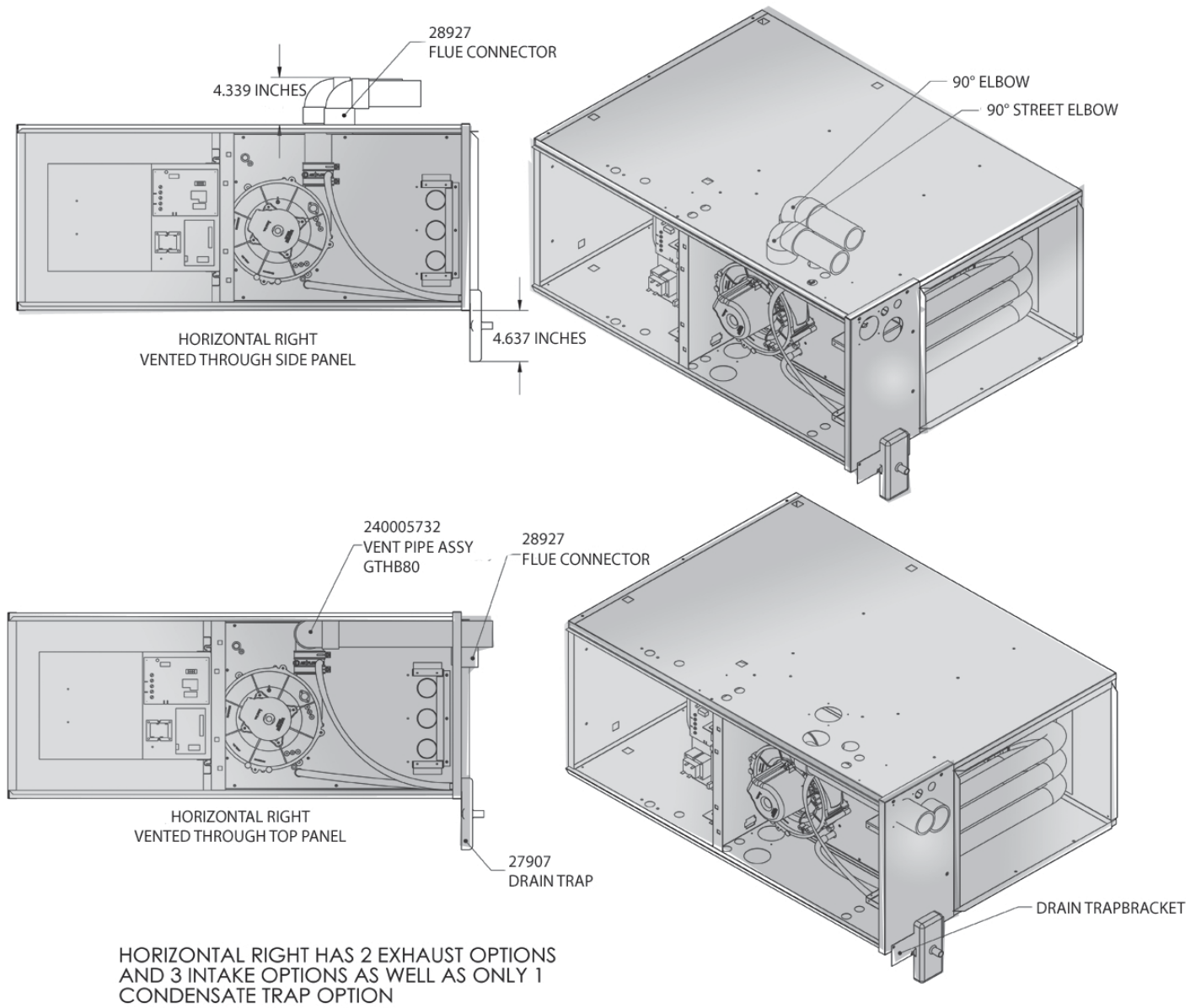
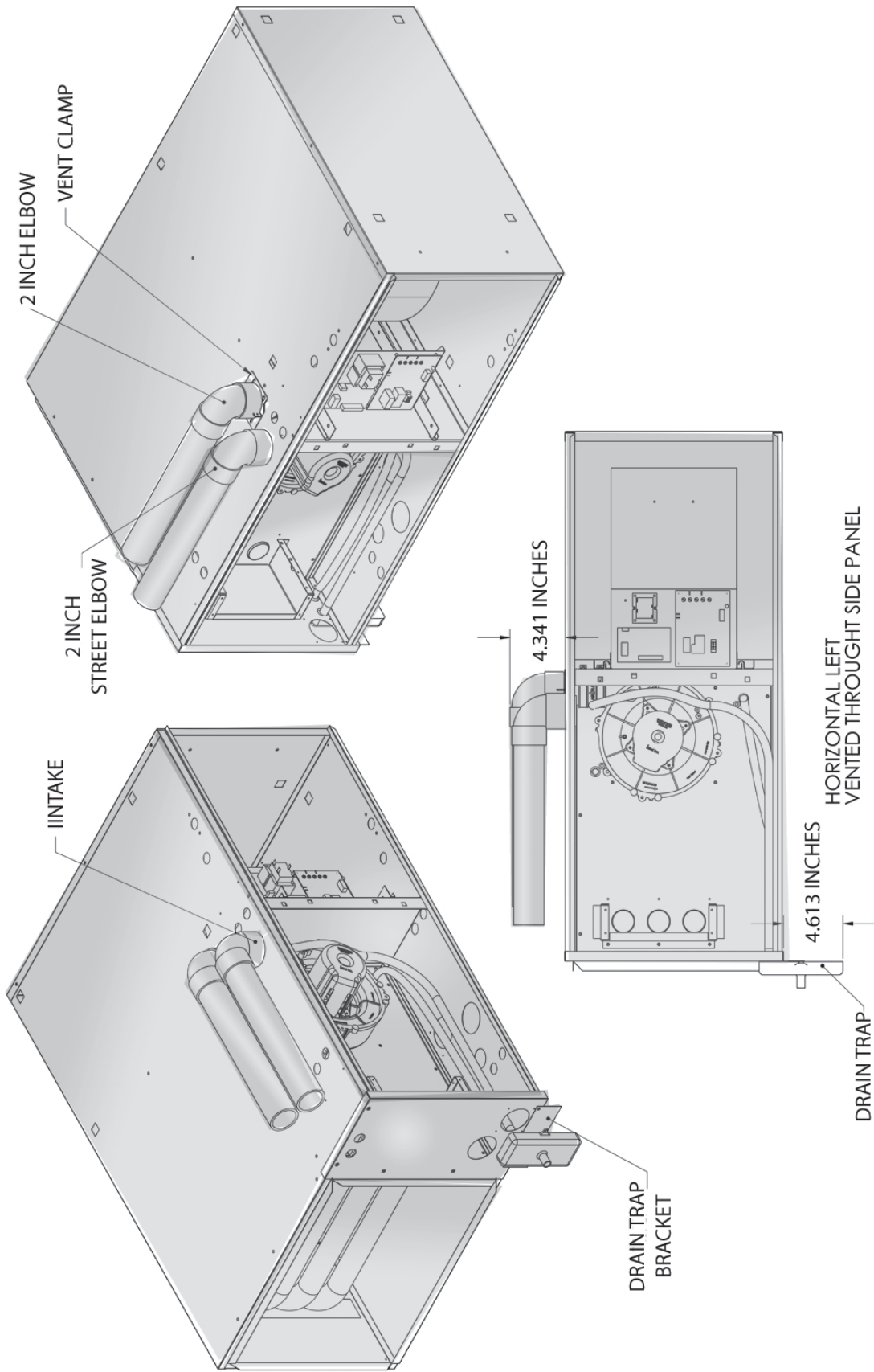
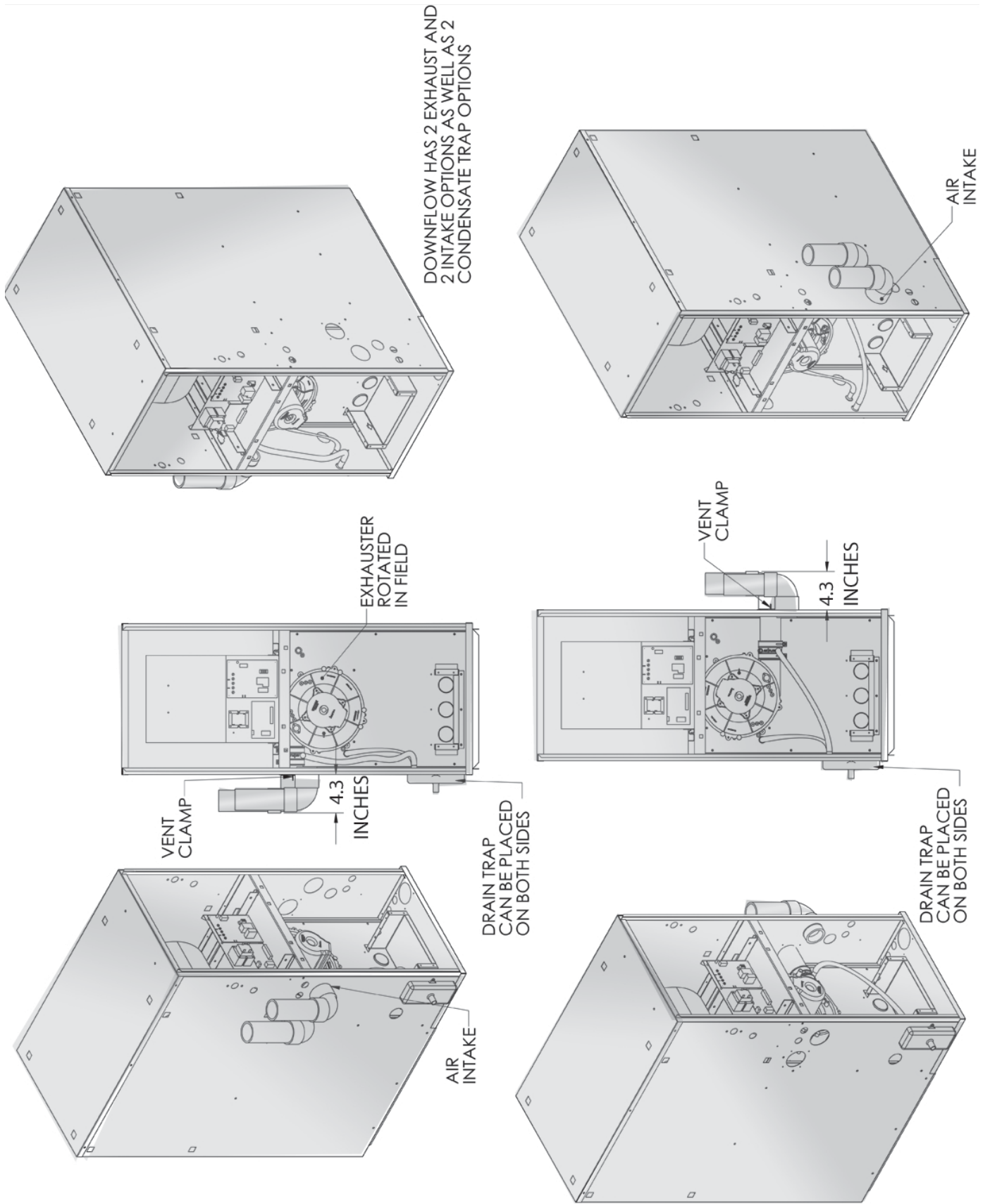

Figure 19- Horizontal Left Option



HORIZONTAL LEFT HAS ONLY
1 EXHAUST OPTION AND 3 INTAKE OPTIONS
AS WELL AS 1 CONDENSATE TRAP OPTION

Figure 20- Downflow Option



The furnace may condense as much as a 4½ pounds of water per hour (approximately 2 imperial quarts, 2½ U.S. quarts or 2¼ liters). It is necessary to make provisions for draining the condensate away. The furnace is supplied with a drain trap assembly.

See **Figures 17-20** for possible locations of the drain trap.

The drain coupling on the inducer shall be fastened with drain holes angled down 15 degrees to permit gravity drain. The drain hose supplied with the furnace is long enough to reach either side panel.

CAUTION



The two inlets to the drain trap are for vent pipe and recovery coil drain. The vent pipe inlet is smaller than the recovery coil drain inlet. Ensure that the drain hoses are properly connected.

Drain Hose Installation

1. Select a drain trap location suitable for the orientation of the furnace and remove the corresponding knockouts. See **Figures 17-20**.
2. Affix the drain trap assembly to the exterior of the side panel when the furnace is upflow or downflow using two screws provided. For horizontal positions the installer will need to use the mounting bracket supplied and secure the bracket to the top panel. Remove two top panel screws and fasten bracket to top panel with removed screws. Secure trap assembly using screws provided to the mounting bracket. See **Figure 19**
3. Slide the short end of the 5/8" formed tube over the appropriate recovery coil drain, and fasten by tightening the tube clamp approximately 1/8" from the end of the tube.
4. Cut the formed drain tube to the required length if necessary, and slide tube over the condensate inlet on the drain trap (larger diameter inlet hole). Fasten by tightening the tube clamp approximately 1/8" from the end of the tube.
5. Rotate exhaustor coupling 15 degrees downwards, and remove the yellow cap over the lowest vent drain outlet. Slide the short end of the 1/2" drain tube on the exhaustor coupling drain. Fasten by tightening the tube clamp approximately 1/8" from the end of the tube.
6. Cut the formed vent drain tube to the required length if necessary, and slide over inlet on the drain trap (smaller diameter inlet hole). Fasten by tightening the tube clamp approximately 1/8" from the end of the tube.
7. All drain tubes must slope towards the drain trap.

CAUTION



Ensure that drain hoses do not create traps prior to the condensate trap assembly. A secondary trap will cause intermittent operation due to the pressure switches opening.

Drain Piping

Condensate from the outlet of the drain trap assembly must be conveyed to a floor drain, sump pit, or, if these are unavailable, to a condensate pump. If using a condensate pump, be sure that it is approved for use for furnace condensate.

CAUTION



Do not drain the condensate outdoors. Do not run the condensate line through areas where freezing might occur. Freezing of condensate can result in erratic furnace operation and in property damage.

Figure 21 - Condensate Trap/Condensate Drainage With Vent



Figure 22 - Condensate Bypass

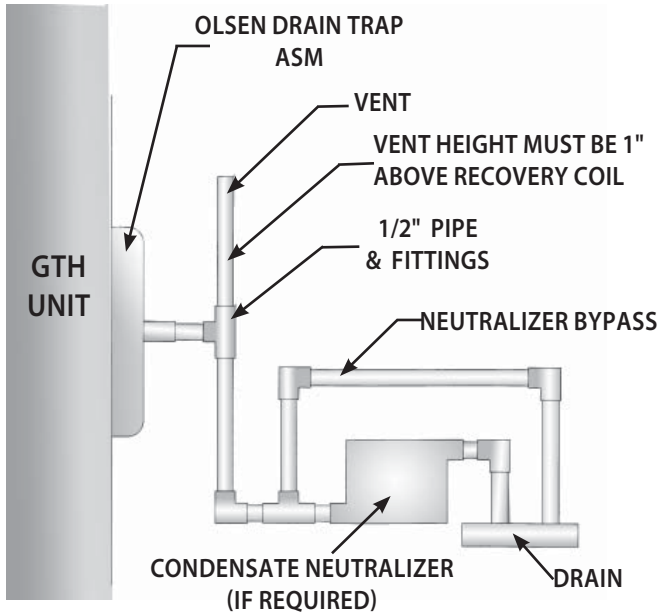

The condensate drainage configuration requires a vent. It takes less than a one inch rise anywhere along the horizontal route of the drain tube to create a vapor lock, which will prevent condensate from draining away freely, and result in erratic furnace operation.

A typical configuration would be to cement the side branch of a 1/2" tee to the drain trap assembly outlet, with the end branches oriented vertically. (Figure 21 & 22)

A 1" piece of 1/2" pipe cemented to the upper end branch will serve as a vent, which will prevent the creation of a vapor lock, and serve as an overflow in the event that the drain line becomes blocked. From the lower end branch connect pipe directly to floor drain or condensate pump.

NOTICE

IMPORTANT: If an air conditioning evaporator coil drain is to share the furnace drain line, it should be connected with a tee fitting downstream from the trap. Do not connect the evaporator coil condensate drain upstream of the furnace drain trap assembly.

Condensate Neutralizers

Some local codes may require the use of a condensate neutralizer. If the furnace condensate is to be routed to a septic system, it may be advisable to use a condensate neutralizer.

Condensate neutralizers such as the Ward Industries 90+ Neutralizer are available through heating supply wholesalers.

When condensate neutralizers are used, it is advisable to install it with an overflow bypass tube. (Figure 22)

NOTICE

IMPORTANT: The condensate drain trap assembly should be full of water before starting the furnace. To fill the condensate drain trap assembly, temporarily remove the vent drain hose from the induced blower assembly elbow/drain fitting, and pour approximately one cup of water down the hose. Water will begin running out the condensate drain trap outlet when it is full. Refasten the vent drain hose to the induced blower assembly elbow/drain fitting.

21 - GAS SUPPLY AND PIPING

Gas Supply

WARNING

THIS FURNACE IS FACTORY EQUIPPED TO BURN NATURAL GAS ONLY.
 CONVERSION TO LP GAS REQUIRES SPECIAL NATURAL GAS TO LP CONVERSION KIT.
 FAILURE TO USE THE PROPER CONVERSION KIT CAN CAUSE FIRE, EXPLOSION, CARBON MONOXIDE POISONING, PROPERTY DAMAGE, PERSONAL INJURY OR LOSS OF LIFE



NOTICE

IMPORTANT: Conversion of this furnace requires specialized equipment. Conversion must be completed by a trained and qualified installer, service agency or gas supplier.

NOTICE

IMPORTANT: Connect this furnace only to gas supplied by a commercial utility or supplier. Private gas wells do not generally provide gas with consistent, uniform and predictable heating values and densities. Many non-commercial wells contain impurities such as sulphur, which may damage the furnace. This furnace cannot operate properly or safely using fuels outside normal commercial standards.

Gas Piping

In Canada, the gas piping should be installed in accordance with CAN/CGA-B149.1 and 2, and in accordance with any local codes.

In the United States, the gas piping should be installed in accordance with NFPA 54 / ANSI Z223.1 and any local codes.

If local codes allow the use of a flexible gas appliance connector, always use a new listed connector. Do not use a connector, which has previously serviced another gas appliance.

NOTICE

IMPORTANT: To maintain a good seal in the burner area, the gas piping through the side panel into the furnace must be ½” Schedule 40 black iron pipe. The pipe passes through a special rubber grommet that is custom manufactured to seal tightly around the gas pipe. See **Figure 23**.

Figure 23 - Furnace Gas Pipe Connections (Note Rubber Grommet)



The gas piping may enter the furnace from either side. Once the routing of the gas pipe is determined, select and remove the applicable knockout and install the grommet within the hole.

Install a BMI ground joint union between the gas valve and the side panel to allow easy removal of the burner for service purposes.

NOTICE

IMPORTANT: Always use a backup wrench to prevent twisting of the control assembly and gas valve. Any strains on the gas valve can affect positioning of the orifices relative to the burners. This could result in faulty burner operation.

Install a manual gas shut-off valve and drip leg as close to the furnace as possible. Some local codes call for the manual gas shut-off valve to be located between 4 to 5 feet above floor level to prevent tampering by small children. Ensure that the valve is readily accessible.

NOTICE

IMPORTANT: Ensure that the manual shut-off valve and gas valve are not subjected to high pressures.



WARNING

Disconnect the manual shut-off valve and gas valve during any pressure testing that exceeds ½ p.s.i.g. (3.45 kPa).

Gas Inlet Pressure

The natural gas inlet supply pressure should be 5” to 7” w.c. (7” w.c. recommended. The LP gas inlet supply pressure should be 11” to 14” w.c. (12” w.c. recommended). These pressures must be maintained while all gas fired appliances are operating at maximum conditions.

NOTICE

IMPORTANT: Do not exceed 14” w.c. inlet pressure with either fuel.

The gas valve has an adjustable internal regulator for controlling burner manifold pressure. Burner manifold pressure is listed on the furnace rating plate.

Leak Testing

All new gas piping installations should be pressure tested as specified by CAN/CGA-B149.1 & 2, or NFPA 54 ANSI Z223.1 or ANSI/NFPA 58, “Standard for the Storage and Handling of Liquefied Petroleum Gases.”

Gas piping that has not been pressure tested, from the manual shut-off valve to the furnace gas valve for example, should be leak tested using an electronic combustible gas detector, a commercially prepared leak detector, or other locally approved method. A leak detector solution can be prepared by mixing a small quantity of dish detergent with water and daubing it onto the gas piping, especially the joints.

Purging Gas Lines

WARNING

NEVER PURGE A GAS LINE INTO THE COMBUSTION CHAMBER.



NEVER USE A MATCH, TAPER, CIGARETTE LIGHTER, FLAME OR ANY OTHER IGNITION SOURCE TO CHECK FOR LEAKS IN A GAS LINE.

FAILURE TO ADHERE TO THIS WARNING CAN CAUSE A FIRE OR EXPLOSION RESULTING IN PROPERTY DAMAGE, PERSONAL INJURY, OR LOSS OF LIFE.

22 - CONVERSIONS

HIGH ALTITUDE: In Canada, the furnace may be converted for high altitude (2000-4500 feet) by changing the burner orifices. The Conversion Kit part number 550001334 contains both natural gas and LP gas orifices. (**Table 7**)

In the United States, the modifications for high altitude are based on a 4% reduction of input capacity for every 1000 feet above 2000 feet above sea level. **Table 6** illustrates the impact of altitude for selected elevations. Consult with local fuel suppliers or authorities to determine local regulations or customs.

NATURAL TO LP GAS: This series furnace is manufactured as a natural gas (sea level) appliance that may be converted to LP gas through use of the Conversion Kit part number 550001335. This kit contains the orifices needed for all models, the regulator spring for the gas valve, and a label to affix adjacent to the appliance rating plate to alert subsequent service technicians of the conversion.

LP TO NATURAL GAS: Although the furnace is manufactured initially as a natural gas appliance, if, after an LP gas conversion it becomes necessary to convert back to natural gas and the original parts are unavailable, The Conversion Kit part number 550001334 may be obtained.

TABLE 6 - HIGH ALTITUDE SPECIFICATIONS (U.S.A.)

MODEL	ALTITUDE (FT)	ORIFICE SIZE (DMS)	
		NATURAL	LP GAS
All	0-2000	45	55
	2000-3000	48	56
	3000-4000	49	57
	4000-5000	50	58
	5000-6000	51	60
	6000-7000	52	61
	7000-8000	53	62
	8000-9000	54	63
	9000-10000	55	65

TABLE 7 - HIGH ALTITUDE SPECIFICATIONS (CANADA)

MODEL	ALTITUDE (FT)	INPUT BTU/HR	OUTPUT BTU/HR	ORIFICE SIZE (DMS)		QTY.
				NATURAL	LP GAS	
40	0-2000	40000	37200	45	55	2
	2000-4500	36000	33480	46	56	
60	0-2000	60000	55800	45	55	3
	2000-4500	54000	50220	46	56	
80	0-2000	80000	74400	45	55	4
	2000-4500	72000	66960	46	56	
100	0-2000	100000	93000	45	55	5
	2000-4500	90000	83700	46	56	
120	0-2000	120000	111600	45	55	6
	2000-4500	108000	100440	46	56	

Figure 24 - Inshot Burner Assembly

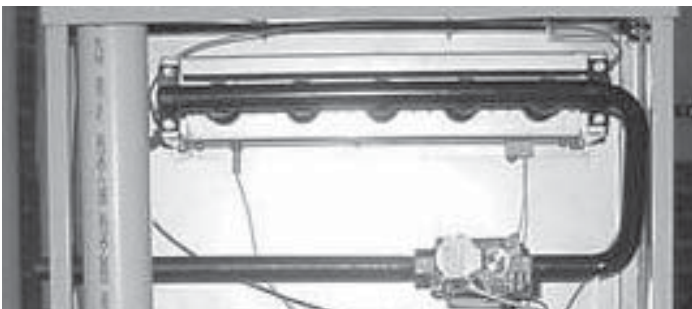

Conversion Steps

To convert from sea level to high altitude, from natural gas to LP gas, or from LP gas to natural gas, follow these steps:

1. Turn off gas supply to the furnace.
2. Shut off electrical power to the furnace.
3. Remove the front door to expose the gas train and burner assembly.
4. Unfasten the ground joint union between the gas valve and gas supply piping if applicable.
5. Unplug the two wires connected to the gas valve.

6. Unfasten the burner manifold pipe from the burner assembly. It is held in place by 2 screws on either end of the manifold pipe.
 7. Remove the existing orifices with a 7/16" socket, box or open end wrench. Install the replacement orifices. The orifice spuds are brass, and do not normally require pipe dope. A light grease may be used to lubricate the threads. The orifice spuds have tapered threads. **Do not over-tighten!!**
 8. If completing a fuel conversion, remove the protective screw cap from the gas valve regulator adjustment. Remove the regulator adjustment screw by turning it counter-clockwise. Remove the existing regulator spring.
 9. Install the new regulator spring.
- NOTICE**

NOTE: If converting the regulator spring is tapered, the tapered end (small end) is inserted back into the gas valve regulator adjustment cavity.
10. Re-install the adjustment. Give it 4 full clockwise turns initially. Do not re-install the protective screw cap yet.
 11. Re-install the burner manifold pipe assembly following steps 4, 5, and 6 in reverse order.

If, in all other respects, the furnace is ready to be fired, continue with the following steps. If not, complete the remainder of the installation and return to these steps before starting the "Start-up & Setup" section.

Figure 25 - Honeywell Gas Valve

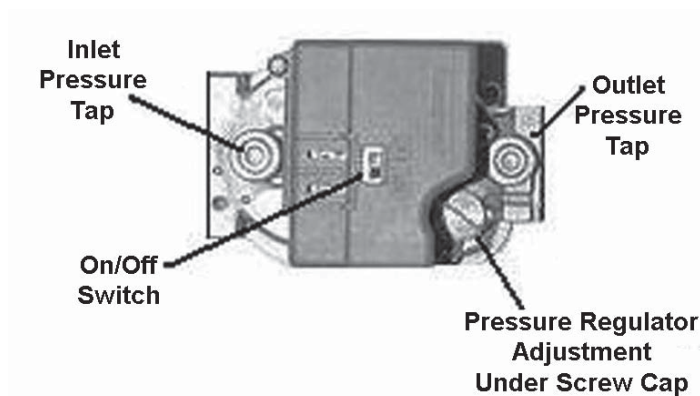

Setting The Gas Pressure

HONEYWELL VALVE

1. Remove the allen head 3/16" manifold pressure tap plug. Install a 1/8" MPT to 1/8" barb fitting.

2. Connect a U-tube manometer to the gas valve pressure tap adapter fitting. The manometer should be capable of reading 0-15" w.c.
 3. Turn on the gas supply and electrical power to the furnace.
 4. Start the furnace.
 5. Note the gas manifold pressure. It should be 3 1/2" w.c. (Natural Gas) or 10 1/2" w.c. (LP).
 6. Turn the adjustment screw clockwise to increase manifold pressure or counterclockwise to reduce manifold pressure.
 7. When the correct pressure has been established, securely replace the regulator protective screw cap.
 8. If the pressure remains steady and on target after tightening the cap, shut off the gas at the manual valve and remove the U-tube manometer.
 9. Remove the barb adapter and replace the pressure tap plug.
- If problems were encountered with obtaining enough pressure on the manifold, first examine the gas piping system to ensure that it is correctly sized. Pipe sizing is specified in CAN/CGA-B-149.1 & 2, and in NFPA 54 / ANSI Z223.1. Be sure to check for restrictions, partially closed valves, etc.

Testing The Gas Pressure

When the installation is completed to the "Start-up & Setup" stage, test the gas input pressure by following these steps:

HONEYWELL VALVE

1. Remove the allen 3/16" manifold pressure tap plug. Install a 1/8" MPT to 1/8" barb fitting.
2. Connect a U-tube manometer to the gas valve pressure tap adapter fitting. The manometer should be capable of reading 0-15" w.c. (See **Figure 27**).
3. Turn on the gas supply and electrical power to the furnace.
4. Start the furnace, and any other gas burning appliances on the same gas piping system.
5. Note the gas inlet pressure. It should be 5-7" w.c. (Natural Gas) or 11-14" w.c. (LP).
6. If working on a natural gas system, contact the gas utility. They may insist on any service regulator adjustments being made by their own staff.
 - A. If working on a propane system, consult the fuel supplier. They too may insist on any service regulator adjustments being completed by their own staff. If permission is granted to adjust the regulator, adjustments are made in a similar fashion as the gas valve regulator.
 - B. Turn the adjustment screw clockwise to increase manifold pressure or counter-clockwise to reduce manifold pressure. (See **Figure 26**)

WARNING



ALL REGULATOR ADJUSTMENTS MUST BE DONE BY A TRAINED, QUALIFIED TECHNICIAN. IMPROPER MODIFICATIONS OR ADJUSTMENTS CAN RESULT IN FIRE OR EXPLOSION CAUSING PROPERTY DAMAGE, SEVERE PERSONAL INJURY OR LOSS OF LIFE.

8. Check burner manifold pressure if changes were made to the inlet pressure and adjust if necessary.
9. Shut off the gas at the manual valve and remove the U-tube manometer.
10. Remove the barb adapter and replace the pressure tap plug.

In some circumstances, high inlet pressure can be remedied with the use of an inline appliance regulator. If an inline appliance regulator is used, ensure that it has the capacity to adequately handle the gas volume required by the furnace and any other appliances receiving gas from the header serving the furnace.

Figure 26 - Regulator Adjustment

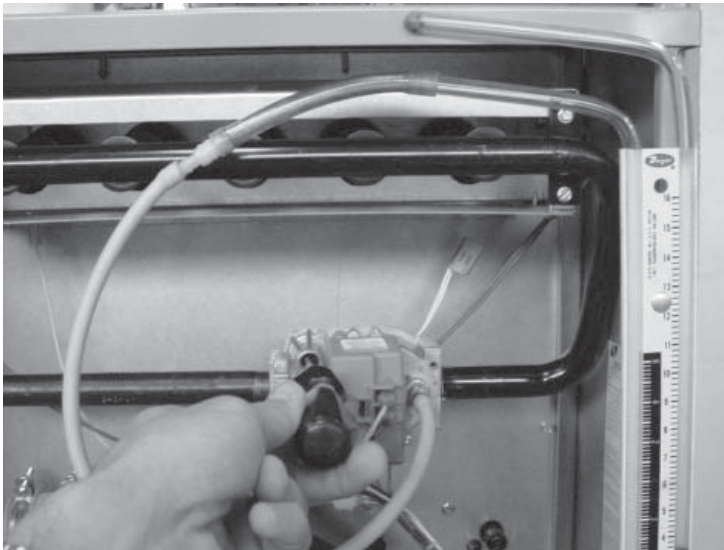

7. When the correct pressure has been established, securely replace the service regulator protective screw cap.

Figure 27 - Manometer Measuring Gas Inlet Pressure

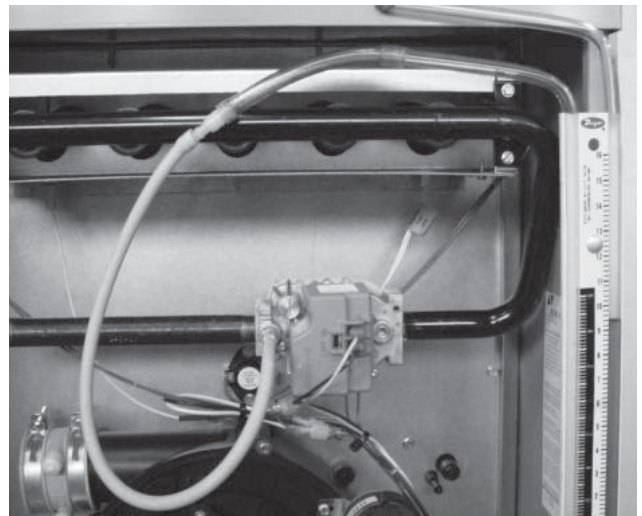

23 - ELECTRICAL SPECIFICATIONS

Electrical Wiring & Connections

Before proceeding with the electrical connections, ensure that the available electrical supply is compatible with the voltage, frequency and phase listed on the appliance rating plate.

All furnaces are rated 120 vac, 60 Hz, 1 Ø. The amperage rating is 15 amps or less.

Each furnace requires a dedicated 20 amp over-current device, either a 20 amp circuit breaker or a 20 amp Type D time delay fuse. It is permissible to connect furnace accessories such as humidifier transformers, condensate pumps and electronic air cleaners. If adding accessory equipment to the furnace circuit, ensure that the combined amperages listed on the appliance rating plates does not exceed the rating of the over-current device.

WARNING



SHUT OFF ELECTRICAL POWER AT THE FUSE BOX OR SERVICE PANEL BEFORE MAKING ANY ELECTRICAL CONNECTIONS. FAILURE TO DO SO CAN CAUSE ELECTRICAL SHOCK RESULTING IN PERSONAL INJURY OR LOSS OF LIFE.

WARNING



THE FURNACE CABINET MUST HAVE AN UNINTERRUPTED GROUND.
A GROUND WIRE IS PROVIDED IN THE ELECTRICAL JUNCTION BOX.
DO NOT USE GAS PIPING AS A GROUND.
FAILING TO GROUND THE FURNACE PROPERLY CAN RESULT IN ELECTRIC SHOCK RESULTING IN PERSONAL INJURY OR DEATH.

In Canada, all electrical work must be in accordance with the latest edition of CSA-C22.1, Canadian Electrical Code Part 1, and any applicable local code.

In the United States, all electrical work must be in accordance with the latest edition of the National Electrical Code, ANSI / NFPA 70.

Although a suitably located circuit may serve as a service switch, a separate service switch is recommended. A separate service switch is necessary if the circuit breaker is in a location where accessing it would require getting close to the furnace, or if the furnace is located between the main electrical panel and the entry to the furnace room. The furnace switch (service switch) should be clearly labeled, and installed in a location where it is not likely to be mistaken as being a light switch or similar control.

Figure 28 - Electrical Connections / Molex Connector

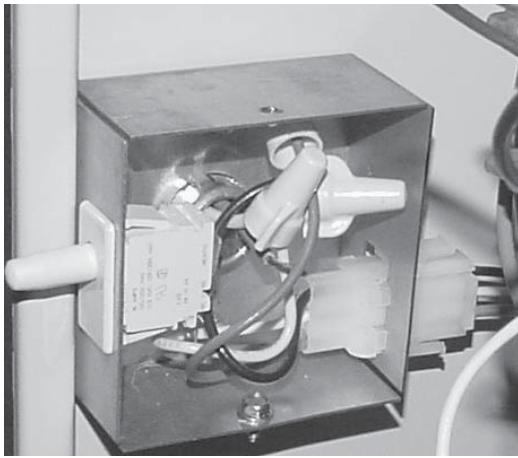
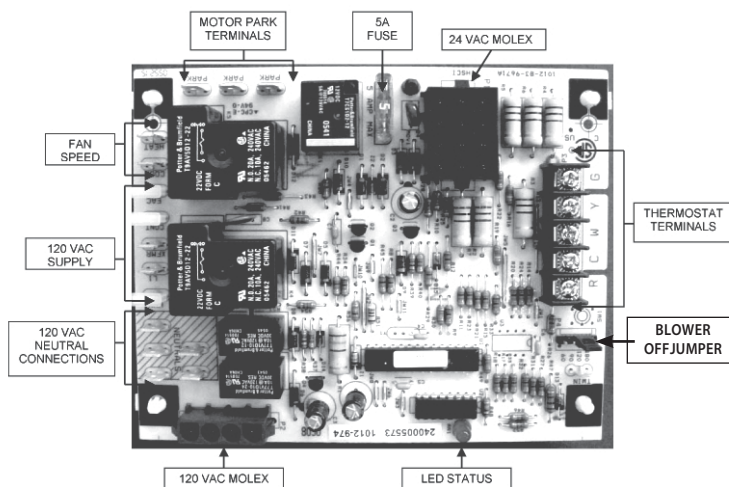

Figure 29 - Integrated Furnace Control



120v Furnace Connection

The furnace is shipped fully wired except for the connections to the house wiring. The furnace power connections are made in a junction box inside the blower compartment. The junction box is factory installed on the left hand side; however, it may be moved to the right hand side. The junction box contains a BLACK wire to be connected with L1 (hot), a WHITE wire to be connected with L2, the Neutral, and a GREEN wire to be connected to the ground.

NOTICE

NOTE: Use good quality wire nuts such as Marrette® connectors, Ideal® wire nuts, etc.

NOTICE

IMPORTANT: Use copper conductors only

If the junction box must be moved to the right hand side of the unit:

1. Unfasten the junction box from the left hand side.
2. Remove the right side panel knock-out.
3. Remove the junction box cover hook screw and re-install it on the opposite side of the box.
4. Fasten the junction box to the right hand panel.

NOTICE

NOTE: L1 (hot) and L2 (neutral) polarity must be observed when making field connections to the furnace. The ignition control may not sense flame if L1 and L2 are reversed. The ground is also essential.

NOTICE

IMPORTANT: Electrical wiring and components must be protected from moisture including water and condensate.

WARNING



THIS FURNACE IS EQUIPPED WITH A BLOWER DOOR SAFETY SWITCH. DO NOT DISABLE THIS SWITCH. FAILURE TO FOLLOW THIS WARNING CAN RESULT IN ELECTRICAL SHOCK, PERSONAL INJURY, OR LOSS OF LIFE.

24 - LOW VOLTAGE WIRING

The low voltage terminations are located in the control box mounted to the blower assembly. The furnace is air conditioning ready. Insert the thermostat and air conditioner contactor low voltage wiring through a knockout provided in the side panel above the supply voltage knockout using a field supplied bushing. Route the control wiring to the control panel to connect to the 24 volt termination screws.

Thermostat

The room thermostat must be compatible with the integrated control in the furnace. Electromechanical thermostats should be rated 30V / 1.5 amps. See **Figure 29**.

Most electronic or microprocessor based thermostats except those with “current robbing” circuits should work satisfactorily. Consult the instructions of the thermostat manufacturer for technical and installation details.

Most compatibility problems can be overcome by the use of an isolation relay. The isolation relay should be SPST with a 24 volt coil. The switch ratings should be a minimum of 0.5 amps. (**Figure 30**)

The thermostat and control wiring should be a minimum of 18 AWG copper. Excessive lengths of wire may result in enough voltage drop to impair the proper functioning of the furnace. For thermostat wires in excess of 25 feet, use 16 AWG; 50 feet, use 14 AWG.

Figure 30 - Isolation Relay

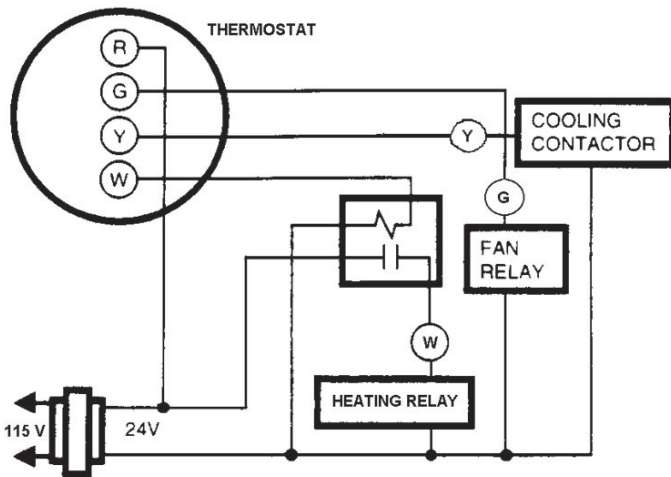

Thermostat Location

The thermostat should be located approximately 5 feet above the floor, on an inside wall where there is good natural air circulation, and where the thermostat will be exposed to average room temperatures. Avoid locations where the thermostat will be exposed to cold drafts, heat from nearby lamps or appliances, exposure to sunlight, heat from inside wall stacks, etc.

Thermostat Heat Anticipator Setting: 0.1 AMP (Honeywell)

25 - OPTIONAL ACCESSORIES (FIELD SUPPLIED/INSTALLED)

Electronic Air Cleaner

The control modules have provisions to supply power and control an electronic air cleaner rated at 120vac, 1.0 amp max. 120 volt power will be available at these terminations whenever the circulating fan is operating in the heating or cooling modes.

Power Humidifier

The control module has provisions to supply power and control a line voltage humidifier or the primary of a 120 / 24 volt humidifier step down transformer, rated at 120vac, 1.0 amp max.

NOTICE

NOTE: All HUM and EAC terminations are 120V. Do not directly connect 24V equipment to these terminations.

26 - STARTUP PROCEDURES

This furnace is equipped with a HSI (hot surface ignition) device. Each time that the room thermostat calls for heat, the HSI lights the main burners directly. See the lighting instructions on the furnace.

To Start The Furnace

1. Remove the burner compartment access door.

2. Shut off the electrical power to the furnace and set the room thermostat to its lowest setting.

NOTICE

IMPORTANT: Ensure that the manual gas control switch has been in the “OFF” position for at least 5 minutes. Do not attempt to manually light the main burners.

3. Turn the gas control switch to the “ON” position.
4. Replace the burner compartment access door.
5. Restore electrical power to the furnace.
6. Set the room thermostat to a point above room temperature to light the furnace.
7. After the burners are lit, set the room thermostat to the desired temperature.

To Shut Down The Furnace

1. Set the room thermostat to its lowest setting.
2. Remove the burner compartment access door.
3. Turn the gas control switch to the “OFF” position.
4. The furnace appliance shut-off valve may be closed if desired.
5. Power to the furnace must remain on for the air conditioner to work.

WARNING



SHOULD OVERHEATING OCCUR OR THE GAS BURNERS FAIL TO SHUT OFF, CLOSE THE MANUAL GAS VALVE FOR THE FURNACE BEFORE SHUTTING OFF THE ELECTRICAL POWER TO THE FURNACE. FAILURE TO DO SO CAN CAUSE AN EXPLOSION OR FIRE RESULTING IN PROPERTY DAMAGE, PERSONAL INJURY OR LOSS OF LIFE.

BEFORE RESTARTING THE FURNACE, CHECK ALL PLASTIC VENTS AND WIRES FOR DAMAGE.

NOTICE

NOTE: On initial startup, the drain trap assembly will be dry. A dry trap will allow flue gases to flow through the recovery coil drain, which will prevent the condensate from draining from the recovery coil. If enough condensate accumulates in the recovery coil, the recovery coil pressure switch will sense this condition and break its electrical contacts, and extinguish combustion. If this takes place, the induced blower will stop after a brief post-purge cycle, the condensate will drain out and fill the trap. If the thermostat is still calling for heat, the ignition sequence will start again after a 5 minute wait.

Sequence Of Operation

1. Room temperature drops causing the room thermostat heating contacts to close.
2. The induced blower (also called a power venter) begins a pre-purge cycle of 15 seconds.
3. The air proving pressure switch contact closes.

4. After the pre-purge period, the hot surface igniter heats up for 5-14 seconds.
5. The gas valve opens for a 5 second trial for ignition. The gas burners light and the igniter shuts off. (See next section for sequence of operation in the event of a flame failure.)
6. The circulating fan begins 30 seconds after a successful trial for ignition.
7. Furnace continues to run in this state until the room thermostat heating contacts open in response to raised room temperature.
8. With the thermostat heating contacts open, the burner flames extinguish immediately and the induced blower stops after a 5 second post-purge period. Pressure switch contacts open.
9. The circulating fan continues to run until timed out in 60 to 180 seconds, depending on the jumper selection. Factory set for 120 seconds.

In The Event Of Flame Failure:

1. Room temperature drops causing the room thermostat heating contacts to close.
2. The induced blower begins a pre-purge cycle of 15 seconds.
3. If pressure switch contact is closed and has failed to open since the last cycle, all subsequent steps will fail to occur.
4. The air proving pressure switch contact closes. If pressure switch contact fails to close, the ignition sequence will not continue.
5. After the pre-purge period, the hot surface igniter heats up for 10 seconds.
6. The gas valve opens for a 5 second trial for ignition. The gas burners light and the igniter shuts off. If the burners fail to light or if the flame is not sensed, the gas valve closes and, if there have been less than 4 trials for ignition, the sequence returns to Step 5. There is a 30 second purge between trials. If this was the 4th trial for ignition, the ignition sequence goes into a 60 minute soft lockout. After a 5 second post-purge, the induced blower stops and pressure switch contacts open.
7. Also, if the flame signal is lost during burner firing, the gas valve will close and the ignition sequence will begin again at Step 4. If the flame sensing signal is lost more than 3 times during a furnace cycle, the gas valve will close, the ignition sequence goes into a 5 second post-purge, and the induced blower stops. The ignition system then goes into a 60 minute lockout and reattempts the sequence at Step 4. The 60 minute lockout sequence will repeat itself indefinitely. Lowering the room thermostat setting below room temperature for more than 3 seconds or shutting off the electrical supply to the furnace for more than 1 second should interrupt the 60 minute lockout.
8. The circulating fan begins 30 seconds after a successful trial for ignition and the furnace continues to run in this state until the room thermostat heating contacts open in response to raised room temperature.

9. With the thermostat heating contacts open, the burner flames extinguish immediately, the induced blower stops after a 5 second post-purge period. The air pressure switch contacts open.
10. The circulating fan continues to run for 60 to 180 seconds, depending on the jumper selection. Factory set at 120 seconds.

Checking Furnace Input

The natural gas supply pressure should be a maximum of 7" w.c. and minimum of 5" w.c. The burner manifold pressure is factory set to 3.5" w.c.

Since heating values for the gas vary geographically, the actual furnace input and output will vary accordingly. For example, natural gas with a 1000 BTU/cu. ft. heating value will reduce the input to 93% of the rated input. Natural gas with a 1100 BTU/cu. ft. heating value will increase the input to approximately 103% of the rated input. This is not usually a problem; however, adjustments to compensate for this can be made by minor adjustments to the burner manifold pressure or by changing the burner orifice size.

Any adjustments to the burner manifold pressure should be carried out with the use of a manometer or calibrated magnehelic gauge. Do not adjust the gas valve pressure regulator more than ±0.3" w.c. (3.2 -3.8" w.c.)

NOTICE

IMPORTANT: Never adjust the input of the furnace to exceed the input shown on the rating plate.

27 - AIR FLOW

For proper furnace operation, air flow over the heat exchanger is of utmost importance. Insufficient airflow accelerates metal fatigue and failure in the heat exchanger and excessive airflow promotes accelerated corrosion of the heat exchanger.

NOTICE

IMPORTANT: Do not bypass this step of the start up procedures.

Temperature Rise Check

When the duct system is complete and the air filter or filters are in place, determine if the airflow is correct.

1. Insert a duct thermometer in the supply air duct. The thermometer should be placed as close as practical to the furnace, but out of the "line of sight" of the heat exchanger (this prevents false readings owing to radiant heat). Ensure that the thermometer

location is within the duct air stream. Avoid locations such as the inside radius of an elbow, etc.

Table 8 on the following page may be used to evaluate furnace input with a gas meter. If using a gas meter to check the furnace input, be sure that all gas fired appliances other than the furnace are off during the test. The formula for determining the furnace input via the gas meter test dial is:

$$\text{Input} = \frac{\text{Heating Value of Gas} \times 3600}{\text{Time in Sec. for 1 cu. ft.}}$$

where:

- input is expressed in BTU/Hr
- heating value of the gas is expressed in BTU/ft³
- and time is the number of seconds required for the test dial to indicate 1 cubic foot.

If using a gas meter with SI (metric) units:

- 1 cubic foot = 0.0283 cubic meters
- 1 cubic meter = 35.315 cubic feet
- 0.01 cubic meter = 0.3531 cubic feet
- 0.5 cubic meter = 1.766 cubic feet

TABLE 8 shows the actual input of the furnace based on the heating value of the natural gas in BTU/ft³. (See page 43 of this manual)

TABLE 9 shows the meter timings when the furnace is running at rated input, with respect to the heating value of the gas. (See page 43 of this manual)

2. Insert a duct thermometer in the return air duct as close to the furnace as practical. Ensure that the thermometer location will be unaffected by humidifier bypass ducts, etc. Choose a location well within the main air stream.
3. Operate the furnace long enough to obtain steady state conditions.
4. When the two thermometers have stabilized, usually within 5-8 minutes, compare the two readings. Subtract the return air temperature from the supply air temperature. The difference is the temperature rise, also called ΔT.
5. Compare the measured ΔT to the temperature rise range shown on the rating plate.

TABLE 8 - INPUT VALUES

MODEL	RATED INPUT (BTU/HR)	TIME TO CONSUME 1 CU. FT. OF 1075 BTU/FT ³ GAS (SECONDS)	HEATING VALUE OF NATURAL GAS IN BTU/CU. FT.				
			900	950	1000	1050	1100
40	40,000	99	32,727	34,545	36,364	38,182	40,000
60	60,000	66	49,091	51,818	54,545	57,273	60,000
80	80,000	49.5	65,455	69,091	72,727	76,364	80,000
100	100,000	39.6	81,818	86,364	90,909	95,455	100,000
120	120,000	33	98,182	103,636	109,091	114,545	120,000

Input BTU/Hr = Heating Value of Gas (BTU/Cu.Ft.) x 3600 / Time (in Seconds) To Consume 1 Cu.Ft. gas.

TABLE 9: GAS METER TIMINGS

MODEL	METER TEST DIAL	METER TEST DIAL TIMINGS FOR FULL RATED FLOW											
		HEATING VALUE OF GAS - BTU/CUBIC FOOT											
		900		950		1000		1050		1100		2520 (LPG)	
HEAT INPUT		MIN	SEC	MIN	SEC	MIN	SEC	MIN	SEC	MIN	SEC	MIN	SEC
40	¼ ft ³	-	20	-	21	-	22	-	24	-	25	-	57
	½ ft ²	-	40	-	43	-	45	-	47	-	50	1	53
	1 ft ³	1	21	1	26	1	30	1	34	1	39	3	47
	2 ft ³	2	42	2	51	3	-	3	9	3	18	7	34
	0.01 m ³	-	29	-	30	-	32	-	33	-	35	1	20
	0.05 m ³	2	23	2	31	2	39	2	47	2	55	6	40
60	¼ ft ³	-	14	-	14	-	15	-	16	-	16	-	38
	½ ft ²	-	27	-	28	-	30	-	32	-	33	1	16
	1 ft ³	-	54	-	57	1	-	1	3	1	6	2	31
	2 ft ³	1	48	1	54	2	-	2	6	2	12	5	2
	0.01 m ³	-	19	-	20	-	21	-	22	-	23	-	53
	0.05 m ³	1	35	1	41	1	46	1	51	1	57	4	27
80	¼ ft ³	-	10	-	11	-	11	-	12	-	12	-	28
	½ ft ²	-	20	-	21	-	22	-	24	-	25	-	57
	1 ft ³	-	40	-	43	-	45	-	47	-	50	1	53
	2 ft ³	1	21	1	26	1	30	1	34	1	39	3	47
	0.01 m ³	-	14	-	15	-	16	-	17	-	17	-	40
	0.05 m ³	1	12	1	15	1	19	1	23	1	27	3	20
100	¼ ft ³	-	8	-	9	-	9	-	9	-	10	-	23
	½ ft ²	-	16	-	17	-	18	-	19	-	20	-	45
	1 ft ³	-	32	-	34	-	36	-	38	-	40	1	31
	2 ft ³	1	5	1	8	1	12	1	16	1	19	3	1
	0.01 m ³	-	11	-	12	-	13	-	13	-	14	-	32
	0.05 m ³	-	57	1	-	1	4	1	7	1	10	2	40
120	¼ ft ³	-	7	-	7	-	8	-	8	-	8	-	19
	½ ft ²	-	14	-	14	-	15	-	16	-	16	-	38
	1 ft ³	-	27	-	28	-	30	-	32	-	33	1	16
	2 ft ³	-	54	-	57	1	-	1	3	1	6	2	31
	0.01 m ³	-	10	-	10	-	11	-	11	-	12	-	27
	0.05 m ³	-	48	-	50	-	53	-	56	-	58	2	13

TABLE 10 - AIR FLOW (CFM)

MODEL		Blower & Motor HP	SPEED	EXTERNAL STATIC PRESSURE - INCHES W.C.					
Input	A/C Tonnage			0.10	0.20	0.30	0.40	0.50	0.60
40,000	2 Ton	10-6R DD 1/3	High	1085	1044	1001	960	908	864
			Med	990	960	928	894	853	805
			Low ⁽²⁾	680	700	684	675	653	620
60,000	3 Ton	12-7T DD 1/2	High	1510	1454	1411	1374	1321	1265
			M-Hi ⁽²⁾	1341	1318	1281	1246	1206	1168
			M-Lo	996	990	981	969	949	937
			Low	709	685	683	674	658	643
80,000	3 Ton	12-7T DD 1/2	High ⁽²⁾	1652	1621	1599	1563	1524	1473
			M-Hi	1403	1395	1388	1380	1350	1304
			M-Lo	1054	1046	1058	1062	1056	1031
			Low	662	656	663	658	657	629
80,000	4Ton ⁽¹⁾	12-7T DD 3/4	High	1698	1664	1645	1613	1570	1533
			M-Hi	1618	1610	1587	1570	1523	1478
			M-Lo	1623	1594	1564	1560	1516	1449
			Low ⁽²⁾	1506	1471	1460	1439	1391	1337
100,000	3 Ton	11-10 DD 1/2	High ⁽²⁾	1743	1716	1685	1630	1572	1502
			M-Hi	1443	1422	1400	1367	1329	1278
			M-Lo	1036	1017	1011	1001	983	966
			Low	661	625	592	564	539	521
100,000	5 Ton ⁽¹⁾	12-10 DD 3/4	High	2224	2172	2103	2028	1965	1904
			M-Hi	2104	2029	2005	1952	1870	1808
			M-Lo ⁽²⁾	2023	1995	1955	1885	1826	1759
			Low	1804	1772	1742	1709	1659	1592
120,000	5 Ton ⁽¹⁾	12-10T DD 3/4	High ⁽²⁾	2359	2305	2260	2214	2150	2089
			M-Hi	2165	2106	2099	2065	1999	1947
			M-Lo	2059	2038	2003	1950	1933	1860
			Low	1749	1736	1710	1688	1678	1627

⁽¹⁾ TWO RETURNS REQUIRED ⁽²⁾ FACTORY HEATING SPEED

Unless stated differently on the rating plate, the temperature rise should normally range between 35° to 65°F. When adjusting the temperature rise, the ideal temperature is approximately mid-range.

If the measured ΔT is above the approved temperature range, there is too little air flow. It must be increased by selecting a faster fan speed, removing restrictions in the duct work, or adding supply or return duct work.

If the measured ΔT is too low, there is too much air flow. Use a lower speed tap on the multi-speed motor.

Calculating Air Flow

There are circumstances where it may be desirable to know the air flow delivery through the duct system, such as when estimating the amount of air flow available for air conditioning. This can be done

by direct measurement with electronic or sloped manometers and velometers, or by using the formula below.

$$CFM = \frac{\text{Output}}{1.085 \times \Delta T}$$

where:

- CFM is airflow in cubic feet per minute;
- ΔT is the temperature rise; and
- Output is the furnace output capacity from the rating plate.

NOTE: Output will vary directly with the input. If the actual input is below the stated input, the output will be reduced in the same ratio (93%).

Adjusting Blower Speeds

If the blower speeds require adjusting, follow these steps:

WARNING



DISCONNECT THE ELECTRICAL SUPPLY TO THE FURNACE BEFORE ATTEMPTING TO CHANGE THE BLOWER SPEED. FAILURE TO DO SO COULD RESULT IN ELECTRICAL SHOCK RESULTING IN PERSONAL INJURY OR LOSS OF LIFE.

1. Remove the blower compartment door.
2. Unfasten the two sheet metal screws securing the blower assembly to the blower division panel.
3. Slide the blower assembly out far enough to access the motor electrical wiring. (Only required if motor is equipped with a power block. There are three colored wires from the motor.)
4. If the motor is equipped with a power block, remove the blue wire from the existing termination and re-install it on the desired termination.

Figure 31 - Piggy-Back Connector

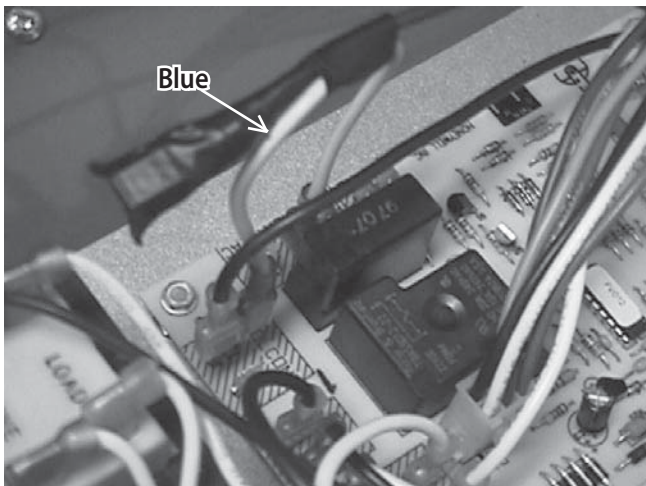

Remove blue wire from HEAT termination, tape it off, replace it with a jumper. Connect the black wire and jumper to COOL.

If the motor has permanent leads, the speed is changed at the control module. Remove the wire from the HEAT termination of the control module and plug in the desired wire on the HEAT termination.

When this configuration is used, the following color codes are used:

Black - High Speed

Blue - Medium-High Speed

Yellow - Medium-Low Speed

Red - Low Speed.

The unused leads are connected to the Park terminations.

(See **Figure 29**)

NOTICE

IMPORTANT: If the heating speed and cooling speed are to be the same, remove the cooling lead from the control, tape it off, then install a piggyback connector from the control HEAT termination to the COOL termination.

(See **Figure 31**)

UNDER NO CIRCUMSTANCE MAY TWO MOTOR WINDINGS BE POWERED SIMULTANEOUSLY.

The piggy-back connector is used for both types of motor wiring configuration; wiring block and permanent lead.

5. Slide the blower assembly back into position, and refasten with the sheet metal screws.
6. Re-install the blower compartment door.
7. Re-check temperature rise.

NOTICE

NOTE: Temperature rise should always be re-checked whenever blower speed is changed.

Setting Blower "Off" Timings

All the control systems allow flexibility in the FAN OFF delay function. The control is located in the blower compartment. Follow the same steps as listed in blower speed adjustment to access the control. The United Technologies control boards use a jumper to change off timing. Factory set at 120 seconds.

Continuous Fan Operation

The control board has an available connection for continuous fan operation. When used, the speed that is connected to this termination is constantly energized until a call for heating or cooling is introduced. Once the heating or cooling fan on delay has completed (5-30 seconds) the continuous fan connection is de-energized and the selected heating or cooling speed is energized.

After the call for heating or cooling is terminated and the fan off delay has completed (40-180 seconds) the heating or cooling speed is de-energized and the continuous fan speed selected is energized.

NOTICE

IMPORTANT: Do not select speeds below 800 rpm for continuous fan. This may cause premature motor failure.

WARNING



DISCONNECT THE ELECTRICAL POWER SUPPLY TO THE FURNACE BEFORE ATTEMPTING ANY MAINTENANCE. FAILURE TO DO SO CAN CAUSE ELECTRICAL SHOCK RESULTING IN PERSONAL INJURY OR LOSS OF LIFE.

CAUTION



Label all wires prior to disconnection when servicing controls. Wiring errors can cause improper and dangerous operation.

Always verify proper operation after servicing.

Air Filter

The filter should be inspected frequently and cleaned as necessary. We recommend a monthly inspection at first, perhaps coinciding with the arrival of the monthly fuel bill as a reminder. The frequency may be increased or decreased depending on experience and conditions.

Avoid the use of the fiberglass throw-away filters. They tend to block up quickly, which may result in higher than normal operating temperatures, and lower efficiency.

Some paper media high efficiency filters, sometimes identified as HEPA filters can do an effective and excellent filtration of the air; however, some models may also cause a large pressure drop across the filter. The contractor should assess the capabilities of the duct system to deliver sufficient air flow if this type of filter is considered.

RECOMMENDED: Electronic air filters using electrostatic precipitation to remove dust are an excellent filtration device. A 16" x 25" model is an ideal fit with this furnace in the case of a side mounted return air inlet. The furnace control module is supplied with electrical terminations for use with electronic air cleaners.

A 16" x 25" x 1" filter kit part number 550001458 can be ordered for use on this appliance. This kit includes the filter rack and washable filter.

NOTICE

NOTE: If two return air inlets are used, both must be equipped with filters.

CAUTION



Do not operate the furnace for prolonged periods of time without an air filter.

A portion of the dust entrained in the air may lodge in the supply air duct work and registers. Any recirculated dust particles will be heated and charred by contact with the furnace heat exchanger. This residue will soil ceilings, walls, drapery, carpets, and other household articles.

Lubrication

Both the induced draft blower motor and circulating fan motor are ball-bearing type motors. Neither requires routine lubrication.

NOTICE

IMPORTANT: The motor bearings were pre-lubricated by the motor manufacturer. Do not attempt to lubricate them. Excess lubrication will void the warranty, shorten the service life if the motors, and will attract the buildup of dust and dirt.

The induced blower motor and circulating fan motor must be cleaned on a periodic basis by a qualified service technician. Dust buildup in the ventilation ports of the motor will cause the motor to not dissipate heat properly resulting in reduced service life.

Terminations

The combustion air and exhaust terminations should be inspected occasionally to ensure that they are free of obstructions and debris. If screens were used in either termination, ensure that they are free of debris, corrosion, or anything preventing the free flow of air. In weather conditions when snow build-up occurs, the homeowner should inspect the vent termination and air intake regularly to ensure they are free and clear of snow. Maintain at least one foot of clearance between snow build-up and vent/combustion air intake openings at all times. Clear away excess snow to maintain this clearance.

Figure 32 - Snow Clearance

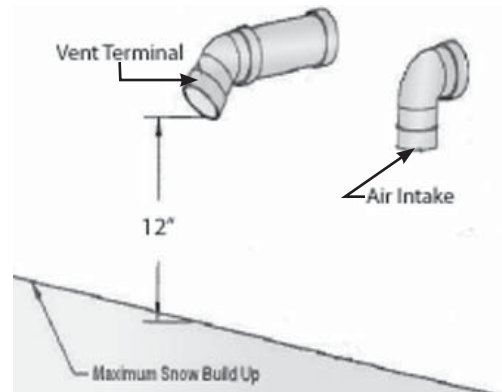

Intake Air/Exhaust Piping

The combustion air intake piping and exhaust piping should be inspected periodically for sags, evidence of leakage etc. If either condition exists, contact your installation contractor, service agency or fuel supplier.

WARNING



Holes in the exhaust piping or furnace heat exchanger can allow toxic fumes to enter the home and circulate through the duct system resulting in carbon monoxide poisoning or death. If leaks are found in the furnace heat exchanger, it must be replaced.

Operating Tips

1. Clean air filters maximize efficiency and reduce heating costs.
2. During the heating season, keep windows and doors closed to reduce the heating load on the system.
3. Avoid excessive use of kitchen exhaust hoods and other exhaust fans to reduce the heating load on the system.
4. Arrange the furniture and drapes so that the supply air registers and return air grilles are unobstructed.
5. If you have a perimeter duct system, ideally, the warm air should bathe the cold exterior walls. Avoid the use of plastic deflectors on the supply air registers which tend to short circuit the warm air straight into the return air grilles. These deflectors are often the cause of cool draughts across the floor.
6. Avoid placing heat producing appliances such as televisions, radios, lamps, etc. in a location to influence the thermostat.
7. Keep combustible articles at least 3 feet away from the furnace. Do not block access for servicing the furnace. Do not use the combustion air or exhaust piping as a hanger for clothes or anything else.

NOTICE

IMPORTANT: Never attempt to operate the furnace without the blower door and combustion compartment door in place or when the blower has failed.

Annual Inspection/Service

The furnace must be inspected annually by a qualified installation contractor, service agency or fuel supplier. Your annual inspection will normally cover the following:

Heat Exchanger - The heat exchanger should be inspected for corrosion. The flue passages (heat exchanger tubes) should be free of scale or excessive corrosion. The top row of heat exchanger tubing is accessible for cleaning with a small diameter wire-handled brush by removing the burner assembly. The bottom row is only accessible if the heat exchanger is removed and the rear flue box cover is removed. The recovery coil (secondary heat exchanger) may be cleaned by accessing the rear flue box cover or removing the front manifold cover. After clearing accumulated scale, observe the burner flames. If there appears to be flame distortion, check the combustion air intake and exhaust piping and terminations for blockage. Also check for signs of soot in the condensate drainage. If flame distortion continues after eliminating the blockage in the piping as the cause, it may be necessary to replace the tubular heat exchanger.

NOTICE

NOTE: Prior to removal of rear flue box cover or front manifold cover, ensure that replacement gaskets are available to ensure proper sealing of the heat exchanger when re-assembled.

Burners - The burners should be inspected to ensure that they are free of deterioration, dust and debris, and properly aligned with the heat exchanger. In most cases, a simple vacuuming with a brush attachment will adequately clean the burner assembly and burner compartment.



CAUTION

Be careful when working on the burner assembly. The hot surface igniter is fragile and can break easily.

The flame sensor should be inspected and cleaned with fine steel wool or Scotch-Brite™ scrubbing pad. The wiring connection should be checked to ensure that it is tight and corrosion free.

NOTICE

NOTE: This is a critical connection. Small amounts of corrosion can significantly increase the internal resistance of the connection. A relatively small increase in resistance can result in a large decrease in flame signal.

Drainage - The condensate drainage system should be inspected and cleaned if necessary. If the drain trap assembly, or any other component becomes blocked, condensate may backup into the secondary or primary heat exchanger causing nuisance trip-outs of the pressure switches or limit switch. The condensate should be observed for signs of dirt, carbon, debris, etc.

If a condensate neutralizer has been added to the condensate drain, it should be inspected, cleaned, or the condensate neutralizing media should be replaced to ensure clear condensate flow.

Induced Blower - The induced blower motor should be inspected and cleaned if necessary. Clear any dust buildup from the ventilation ports.

Circulating Fan - The condition of the circulating fan should be checked to ensure that it is free of excessive dust buildup, debris, etc. The mechanical fasteners should be inspected and checked for proper tightness and parts alignment. The motor ventilation ports should be cleaned if necessary to prevent restriction to cooling by air over the motor.

Electrical - All electrical connections should be examined to ensure that they are tight and corrosion free. Repair any connections that have become loose or corroded.

Furnace Operation - The furnace should be cycled during the annual inspection and servicing to:

1. Test all safety related controls.
2. Determine that the temperature rise falls within the range shown on the appliance rating plate.
3. Ensure that the burner ignition is smooth and that the flames are smooth soft blue, and not impinging on the heat exchanger.

Troubleshooting Flowchart

SEQUENCE OF OPERATION

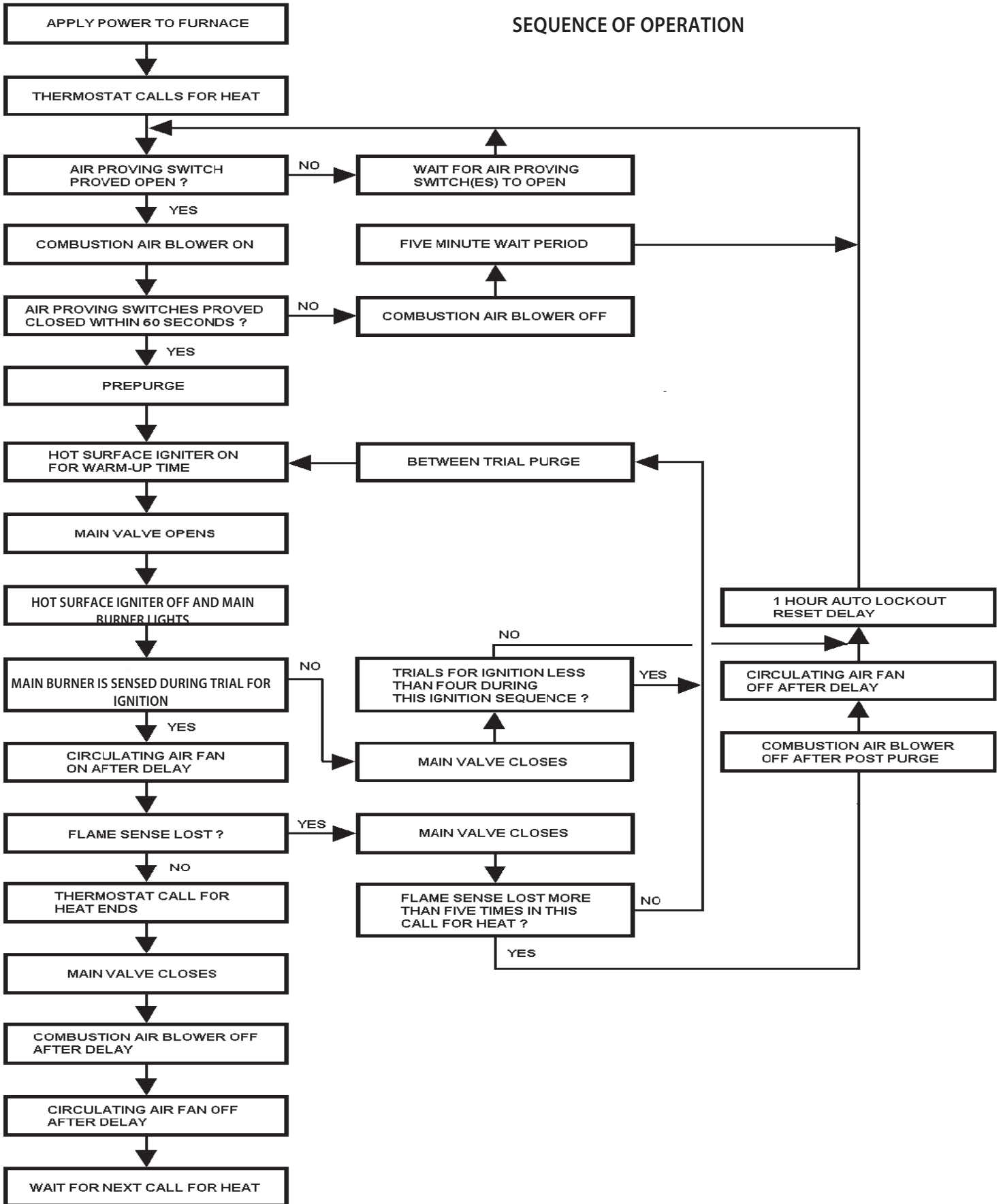

Diagnostic Codes For Status Led

LED Condition	Fault Condition	Diagnostic Check
LED ON	Normal Operation	No action required. Control Okay.
LED OFF	Twin fault or no power	Line voltage input power at L1 and Neutral connectors control board. System wiring harness in good condition and securely connected at both ends. Line voltage removed from one furnace (Twin) and not the other. 24 VAC supply to twinned furnaces should be in phase.
Rapid Flash	Internal control fault	
1 Flash	High limit switch open	Open limit switch. Limit switch and wiring in good condition and securely connected. Check for blocked air filter, correct temperature rise, blower speed selection, closed ducts, etc.
2 Flashes	Pressure switch(s) open with inducer on	Pressure switch(s) operation, tubing, drainage and wiring. Obstructions or restrictions in venting preventing proper air flow. Obstructions or restrictions in drain hoses, condensate trap or drainage system preventing proper condensate removal.
3 Flashes	Pressure switch(s) closed with inducer off	Pressure switch(s) stuck closed. Pressure switch(s) mis-wired or jumpered
4 Flashes	Control lockout due to failed ignition	Gas supply OFF, or gas supply pressure too low to operate furnace. Damaged or broken HSI element. Line voltage input power at L1 and Neutral connectors control board. Furnace not properly earth grounded. Flame sensor rod contaminated or in incorrect position. HSI element located in wrong position. Hot surface element or flame sensor wiring in good condition and properly connected.

28 - DIAGNOSTIC CODES FOR STATUS LED

LED Condition	Fault Condition	Diagnostic Check
5 Flashes	Incorrect line voltage phasing or voltage not present on L1	Check supply voltage to ensure proper polarity to L1 and Neutral connections
6 Flashes	Lockout too many limit switch trips in a call for heat (5)	If the limit switch opens more than 5 times in a single call for heat. Check for blocked air filter, correct temperature rise, blower speed selection, closed ducts, etc.
7 Flashes	Too many pressure switch drop-outs in one call for heat (5)	Pressure switch(s) operation, tubing, drainage and wiring. Obstructions or restrictions in venting preventing proper air flow. Obstructions or restrictions in drain hoses, condensate trap or drainage system preventing proper condensate removal.
8 Flashes	Too many flame sense losses in 1 call for heat (5)	Check system for proper ground. Dirty, oxidized or failed flame sensor
9 Flashes	Limit switch open for more than 150 seconds; Hard lockout	Open limit switch. Limit switch and wiring in good condition and securely connected. Check for blocked air filter, correct temperature rise, blower speed selection, closed ducts, etc.
10 Flashes	Flame present with gas valve off	Flame at main burner. Gas Valve
11 Flashes	Rollout switch open	Check flame rollout switch Ensure wiring is in good condition and securely connected.

Fault Code History

The control stores the last 5 fault codes in memory. When the push-button switch is pressed for less than 5 seconds, the control will flash the stored fault codes when the switch is released. The most recent fault code is flashed first, the oldest last.

Fault history may be cleared by holding the push-button switch for more than 5 seconds.

28 - MAINTENANCE AND TROUBLESHOOTING

IF	AND	CHECK or REPAIR
Induced blower does not energize when call for heat.	No error code.	<ol style="list-style-type: none"> 1. Induced blower wiring. 2. Induced blower. 3. T-stat defective.
Induced blower does not energize.	Error code indicating Pressure Switch failure.	<ol style="list-style-type: none"> 1. Pressure switch(s) stuck closed. 2. Pressure switch(s) is mis-wired or jumpered.
Induced blower is energized.	Induced blower turns off after 60 seconds.	<ol style="list-style-type: none"> 1. Pressure switch(s) stuck open. 2. Pressure switch(s), tubing and wiring. 3. Water in tubing. Reroute tubing to always be above drain hole. 4. Obstruction in furnace combustion air intake or exhaust piping. 5. Obstructions or restrictions in drain hoses, condensate trap or drainage system preventing proper condensate removal.
Pre-purge time has expired	HSI element does not glow red within 10 seconds.	<ol style="list-style-type: none"> 1. Broken or damaged HSI element. 2. Broken or damaged HSI element lead wires. 3. Board failure to power HSI element.
HSI element warm up time has expired and main valve has been energized.	Does not light within trial for ignition period.	<ol style="list-style-type: none"> 1. Gas valve did not open. 2. Inlet gas pressure too low for main burner ignition. 3. Input line voltage too low to heat HSI element. 4. HSI element incorrectly positioned. 5. Clogged or incorrect main burner orifice. 6. Check gas valve on/off switch.

VENTING CHECKLIST		✓
Vent pipe must be sloped to drain from outlet back to furnace.		
Exposed vents and drains must be equipped with heat trace cable.		
Venting pipes exiting house must be well sealed to prevent exhausts from re-entering the house.		
Vents and intake must be 12" above grade. For Massachusetts see page 6.		
In Canada all venting material must be identified as ULC S636 and be readily accessible for visual inspection for the first 3ft. (900mm)		
Use large radius elbows where possible.		
Exhaust vents must not be near windows or other fresh air intakes.		
Support vents firmly. Keep out of work areas to prevent damage.		
Clamp and gasket all vent exits to furnace panels to insure airtight seal.		
Equivalent vent length must be less than the allowable length in <i>Table 4 - Direct and Non-Direct Vent Lengths</i> .		
If there is a choice, the exhaust should be shorter than the intake vent.		
For indirect vent, installer must calculate size of room to determine if an outside air is required.		
Use direct vent for commercial installations that use chemicals (Hair Salons, etc.).		
Avoid exposure to windy side of house.		
Heat Exchanger (suction) drain must be trapped separate from vent drain (pressure). A/C drain must not be inserted before heat exchanger and vent drain trap.		
Exhaust vent and combustion air intake must be located within the same wind pressure zone when installed in a direct vent application using outdoor combustion air.		

REPLACEMENT PARTS LIST

HIGH EFFICIENT GAS FURNACE

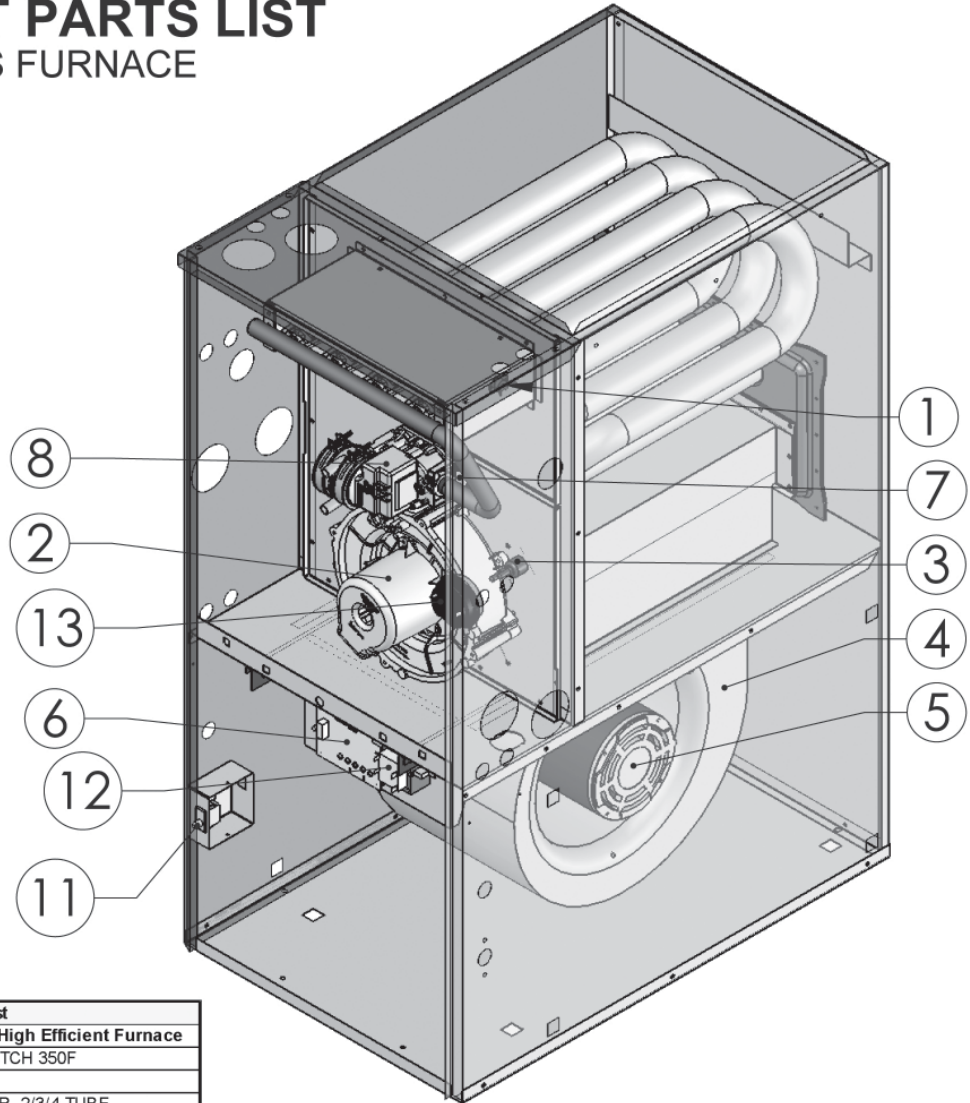

Replacement Parts List		
Item	Kit Number	Repair Parts List for 93% High Efficient Furnace
1	550001515	KIT,FLAME ROLLOUT SWITCH 350F
2	550001516	KIT,IND,BLW.REPL,HI
3	550001522	KIT,FRONT MANIFOLD CVR. 2/3/4 TUBE
3	550001523	KIT,FRONT MANIFOLD CVR. 5/6 TUBE
4	550001519	KIT,BLOWER 10-6 W/WHEEL
4	550001520	KIT,BLOWER 12-7T W/WHEEL
4	550001535	KIT,BLOWER 10-10 W/WHEEL
4	550001536	KIT,BLOWER 12-10T W/WHEEL
5	550001529	KIT,1/3HP 3SPD DD MOTOR W/CAP
5	550001530	KIT,1/2HP 4SPD DD MOTOR W/CAP
5	550001531	KIT,3/4HP 4SPD DD MOTOR W/CAP
6	550001524	KIT,INTEGRATED CNTL. BOARD
7	550001514	KIT,LIMIT SWITCH 160F
7	550001525	KIT,LIMIT SWITCH 150F
8	550001526	KIT,GAS VALVE
9	550001527	KIT,HOT SURF,IGNITOR
10	550001528	KIT,FLAME SENSOR
11	550001532	KIT,DOOR SWITCH
12	550001533	KIT,TRANSFORMER 120V/24V SEC.
13	550001336	KIT,PRESS,SWITCH HI -1.60WC
13	550001518	KIT,PRESS,SWITCH HI -1.70WC
13	550001513	KIT,PRESS,SWITCH HI -1.80WC
14*	550001534	KIT,FUSE 5 AMP.
15*	550001458	KIT,FILTER
16*	29570	KIT,CONCENTRIC VENT, 2" DIA.
17*	29571	KIT,CONCENTRIC VENT, 3" DIA.
18*	550001521	KIT,PARTS BAG
19*	550001517	KIT,WIRE HARNESS HI
20*	550001538	KIT,12T SERIES BLOWER DD HARDWARE
21*	550001537	KIT,10 SERIES BLOWER DD HARDWARE
22*	550001334	KIT,CONV,NG,LP,H/A,GTHB,CAN/US
23*	550001335	KIT,CONV,NG TO LP,GTHB,93%
*Not Shown		

32 - REPLACEMENT PARTS LIST

Replacement Parts List		
Item	Kit Number	Repair Parts List for 93% High Efficient Furnace
1	550001515	KIT,FLAME ROLLOUT SWITCH 350F
2	550001516	KIT,IND,BLW,REPL,HI
		<i>Jake! induced blower with gasket and termination</i>
3	550001522	KIT,FRONT MANIFOLD CVR. 2/3/4 TUBE
		Plastic front manifold cover with gaskets
3	550001523	KIT,FRONT MANIFOLD CVR. 5/6 TUBE
		Plastic front manifold cover with gaskets
4	550001519	KIT,BLOWER 10-6 W/WHEEL
4	550001520	KIT,BLOWER 12-7T W/WHEEL
4	550001535	KIT,BLOWER 10-10 W/WHEEL
4	550001536	KIT,BLOWER 12-10T W/WHEEL
5	550001529	KIT,1/3HP 3SPD DD MOTOR W/CAP
		<i>1/3 HP motor</i>
		<i>7.5 µf capacitor</i>
5	550001530	KIT,1/2HP 4SPD DD MOTOR W/CAP
		<i>1/2 HP motor</i>
		<i>10 µf capacitor</i>
5	550001531	KIT,3/4HP 4SPD DD MOTOR W/CAP
		<i>3/4 HP motor</i>
		<i>20 µf capacitor</i>
6	550001524	KIT,INTEGRATED CNTL, BOARD
7	550001514	KIT,LIMIT SWITCH 160F
7	550001525	KIT,LIMIT SWITCH 150F
8	550001526	KIT,GAS VALVE
		<i>VR8205S5802B 24V Honeywell K2 gas valve set for NG</i>
9	550001527	KIT,HOT SURF,IGNITOR
10	550001528	KIT,FLAME SENSOR
11	550001532	KIT,DOOR SWITCH
12	550001533	KIT,TRANSFORMER 120V/24V SEC.
13	550001336	KIT,PRESS,SWITCH HI -1.60WC
13	550001518	KIT,PRESS,SWITCH HI -1.70WC
13	550001513	KIT,PRESS,SWITCH HI -1.80WC
14*	550001534	KIT,FUSE 5 AMP.
15*	550001458	KIT,FILTER
		<i>Filter rack</i>
		<i>Filter rail</i>
		<i>16" x 25" permanent filter</i>
16*	29570	KIT,CONCENTRIC VENT, 2" DIA.
17*	29571	KIT,CONCENTRIC VENT, 3" DIA.
18*	550001521	KIT,PARTS BAG
19*	550001517	KIT,WIRE HARNESS HI
		<i>Wire harness, supply</i>
		<i>Wire harness, Junction box to Board</i>
		<i>Wire harness, Board to Blower division</i>
		<i>Wire harness, Blower division to Safetys 40/60</i>
		<i>Wire harness, Blower division to Safetys 80/100/120</i>
		<i>Wire harness, Board to Blower Motor</i>
20*	550001538	KIT,12T SERIES BLOWER DD HARDWARE
		<i>48 frame motor mounting band with fasteners</i>
		<i>3 - 12" diameter motor mounting arms</i>
21*	550001537	KIT,10 SERIES BLOWER DD HARDWARE
		<i>48 frame motor mounting band with fasteners</i>
		<i>3 - 10" diameter motor mounting arms</i>
22*	550001334	KIT,CONV,NG,LP,H/A,GTHB,CAN/US
		<i>All fuels and altitudes springs and orifices</i>
23*	550001335	KIT,CONV,NG TO LP,GTHB,93%
		<i>LP spring and orifices</i>
	*Not Shown	

