



**Q95M-200**  
Gas-Fired Direct Vent  
Modulating Hot Water Boiler

P/N# 240006108D, Rev. A [05/08]



**95% AFUE Efficiency**



**MODULATING CAPACITY  
FROM 80 - 200 MBH**

▲ **APPLICATION:** The Q95M-200 Gas-Fired Direct Vent Modulating Hot Water Boiler is available in natural or propane gas with an infinitely modulating capacity from 80 to 200 MBH and an AFUE of 95% (Category IV Venting). The boiler can be used for a wide variety of applications (with or without zones) including radiant floor heating, snow melting, baseboard heating, standing cast iron radiators and coil units. All boilers are factory-assembled with controls and wiring, and tested to ensure dependable performance. The compact size allows for easy installation in a basement, a closet, or an alcove enclosure.

**Benefits:**

- Advanced microprocessor control continuously monitors supply and return water temperature, adjusting boiler output to match building load.
- 95% AFUE efficiency dramatically reduces fuel consumption.

▲ **CERTIFICATIONS AND APPROVALS:** The cast aluminum boiler assembly is manufactured and tested in accordance with American Society of Mechanical Engineers standards (ASME), and certified by Canadian Standards Association (CSA) in the US and Canada. The Annual Fuel Utilization Efficiencies (AFUE) are based on US DOE test procedures and FTC labeling regulations. AFUE and I=B=R ratings are certified in accordance with standards set by The Hydronics Institute Division of the Gas Appliance Manufacturers Association (GAMA). A New York City Materials and Equipment Acceptance (MEA) number is pending.

▲ **WARRANTY:** 95M-200 Series Boilers are backed by a 15-Year Limited Heat Exchanger Warranty and by our reputation for quality and service to customers, based on 75 years of successful hydronic experience.

**FEATURES AND BENEFITS**

▲ **FLEXIBLE DESIGN:** The 95M-200 Series Boiler is engineered with installation flexibility and convenience that benefit both the installer and the homeowner.

- No primary/secondary dedicated piping required (one circulator can service boiler and all zones).
- Option of left, right or rear exit for return plumbing and gas piping.
- Piping connection options on rear and top of unit facilitates multiple boiler installations with boilers located in close quarters.

▲ **ALUMINUM HEAT EXCHANGER:** This boiler employs a cast aluminum heat exchanger with a monoblock design that eliminates the need for mating sections and therefore eliminates leaks between sections. Since the heat exchanger is cast of aluminum instead of iron, it has better heat transfer properties which in turn lead to higher efficiency and cooler exhaust temperatures. These cooler exhaust temperatures create condensation of the flue gas, which would cause corrosion in traditional cast iron heat exchangers.

**Benefit:** Better heat transfer and thermal storage than similarly sized cast iron boilers, resulting in higher efficiency.

▲ **INTEGRATED MODULATING BOILER CONTROL (IMBC):** This appliance incorporates an integrated modulating control that senses the load necessary to heat a structure and therefore uses less fuel than a conventional fixed firing rate boiler when there is a lower than peak demand for heat. The control senses the supply water, return water, and outside air temperatures and calculates the load on the system. It then adjusts the firing rate to deliver the amount of heat that is needed at that particular time.

## 95M-200 GAS-FIRED DIRECT VENT MODULATING HOT WATER BOILER

### Benefits:

- Saves water by redirecting heat where and when it's needed. No waiting for hot water.
- Additional savings with factory standard outdoor temperature reset, which adjusts the water supply temperature for best possible fuel economy based on actual seasonal conditions.

▲ **NTC SENSORS:** The NTC sensors used with this appliance for measuring supply water, return water, and outside air temperature are specially configured to operate with the modulating boiler control.

▲ **MODULATING BLOWER:** The modulating blower provides a means of introducing the gas/air mixture through the burner and into the combustion chamber where combustion can begin and then out the exhaust vent where the combustion products are discharged to the outdoors. The blower is designed to communicate with the modulating control to run at variable speeds dependent on the heat load experienced by the heating system. The variable speeds create pressures felt by the gas valve and gas/air mixer that dictate how much fuel is introduced to the combustion process.

▲ **GAS CONTROL VALVE:** The gas controls in this boiler have been developed for domestic heating appliances with premix burners and automatic direct burner ignition and are suitable for natural and LP gas. The gas controls perform all the functions required to safely regulate gas flow to the main burner of the boiler. The gas valve is directly connected to the gas/air mixer.

▲ **MODULATING BURNER:** This burner is designed to operate over the full range of input for this boiler. The burner can operate under normal (blue flame) and infrared conditions.

▲ **DIRECT SPARK IGNITER (DSI):** This appliance uses a direct spark igniter to ignite the fuel/air mixture in the combustion chamber and sense flame during operation. The DSI is a durable, reliable component that resists breakage due to handling or inadvertent impact with other objects.

▲ **MANUAL RESET LOW WATER CUT OFF (LWCO):** This unit is equipped with a manual reset low water cut off control that protects the boiler against dry firing. This control provides burner cut off if there is an unsafe water loss, which can result from a broken or leaking radiator, pipe, or boiler. A water/glycol mixture up to 50% concentration may be used with the control.

▲ **NORMALLY CLOSED LOW WATER CUT OFF SWITCH:** This switch is normally closed and spring loaded so that,

when depressed, it opens, and closes again when pressure is removed. The switch is used as the manual reset for the low water cut off. When tripped the LWCO will remain in lockout until the water level reaches the probe and the switch is depressed to an open state and then released to a closed state, which sends a signal to the LWCO to resume normal operation. The boiler control reset button must then be pressed to reset from a low water condition. The LWCO switch and control reset button are located on the display panel of the boiler.

▲ **HIGH LIMIT AQUASTAT CONTROL:** The high limit aquastat control determines the maximum boiler water temperature and also provides a means for protecting the boiler and heating system from unsafe operating conditions which could damage the boiler. The aquastat is tied in with the IMBC and is factory set at 200°F (93.3°C) water temperature. The high limit set point is field adjustable and may be set anywhere between 100°F (37.8°C) and 200°F (93.3°C). The field set point adjustment for each installation depends on the heating system's requirements.

▲ **CASTING TEMPERATURE SAFETY SWITCH:** In the event there is a lack of water or too high of a temperature in the boiler, the casting temperature safety switch (located on the top of the aluminum boiler section) shuts down the boiler by turning off power to the Integrated Modulating Boiler Control (IMBC). The boiler may then be manually reset after verifying it is properly filled with water.

▲ **AIR PROVING BLOCKED VENT SAFETY ASSEMBLY:** The air proving blocked vent safety assembly incorporates two pressure switches that are wired in series to discontinue operation of the appliance if there is a problem with the blower or venting system. The normally open switch closes upon the initiation of the blower and functions as an air proving switch. The normally closed switch opens if there is a blockage in the combustion air intake or exhaust vent pipes.

▲ **DRAIN VALVE:** The manual drain valve provides a means of draining the water in the heating system, including the boiler and hot water supply and return piping systems installed above the drain valve. This drain valve is installed in the return piping at the bottom front of the boiler section. Any piping installed below the elevation of this drain valve will require additional drain valves to be installed at low points in the piping systems in order to drain the entire system.

▲ **ASME RATED PRESSURE RELIEF VALVE:** The pressure relief valve is furnished as standard on top of the boiler and provides for pressure relief of the heating system in case of abnormal operating conditions. The valve opens at 30 psig (201 kPa) and is ASME approved.

# BOILER SPECIFICATIONS

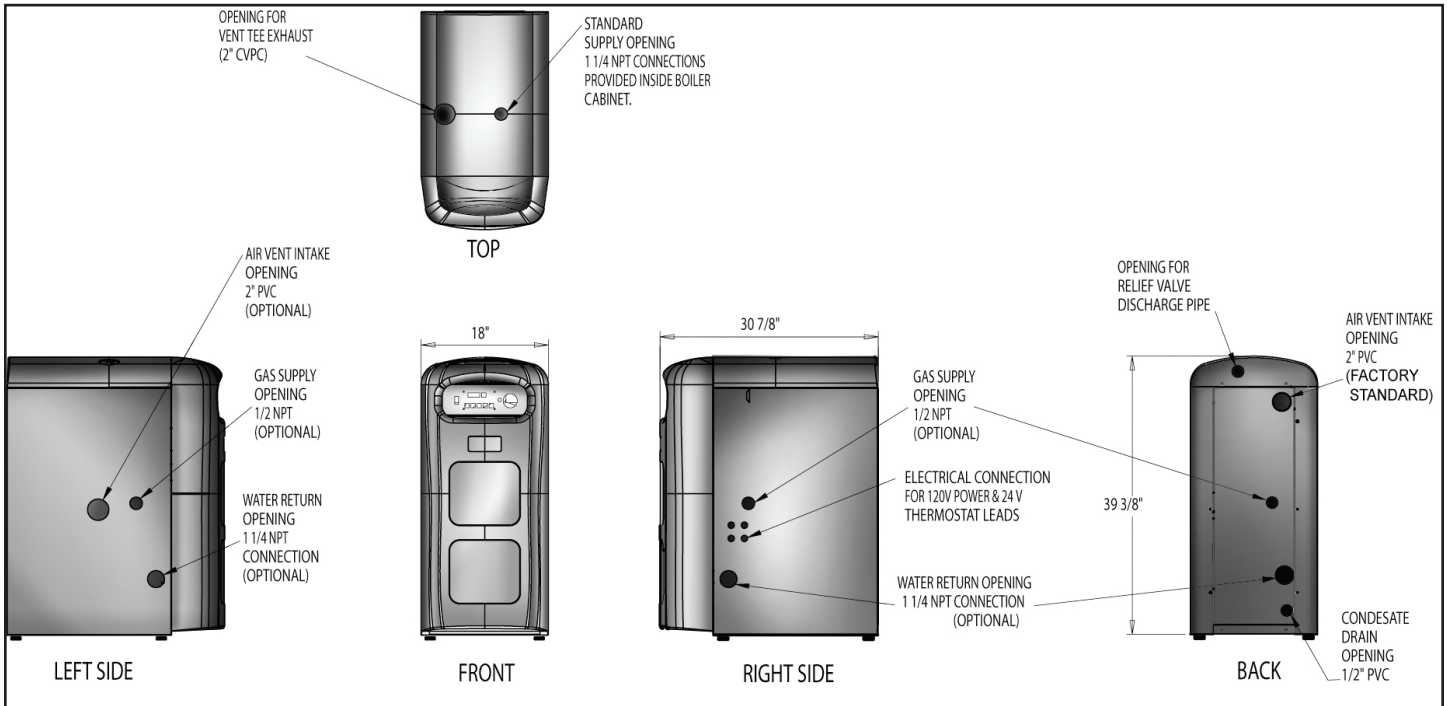

## STANDARD AND OPTIONAL EQUIPMENT

- Aluminum monoblock boiler with painted metal and plastic jacket
- High limit Aquastat
- Circulator 1/25 Hp
- Manual reset LWCO
- Pressure gauge
- Temperature display
- 30 psi ASME rated relief valve
- Air purge vent
- Service switch
- Service receptacle outlet
- Microprocessor based modulating control
- Fully modulating burner
- Modulating automatic gas valve
- Modulating blower
- Direct Spark Igniter
- Manual Reset casting temperature switch
- Air proving / blocked vent safety assembly
- Integral condensate trap

## OPTIONS

- Honeywell AM Kit (allows for external modulation control)
- Concentric Vent Kit
- GCI Kit (allows for PC diagnostic interface)

## ELECTRICAL SPECIFICATIONS

120 Volts AC, 60 Hertz, 1 Phase, Less Than 12 Amps

## CONNECTIONS

**Vent Pipe:** First 2 1/2' is Schedule 80 2" CPVC (Provided), then Schedule 40 3" PVC

**Air Intake:** Schedule 40 3" PVC

**Water In/Out:** 1/4" NPT

**Gas In:** 1/2" NPT

**Condensate Drain:** 1/2" PVC

**Vent Length Runs:** 15' min./60' max.

## BOILER CLEARANCES\*

Dimension	Combustible Construction	Accessibility/ Cleaning	Service
Top	1"	8"	8"
Left Side	1"	24"	24"
Right Side	1"	-	-
Base	1"	-	-
Front	0	24"	24"
Back	6"	-	-
Intake/Vent Piping	0	-	-
Near Boiler Hot Water Piping	1"	-	-

\* All distances measured from the cabinet of the boiler.

## RATINGS & CAPACITIES

### SEA LEVEL RATINGS - NATURAL AND PROPANE GASES

Boiler Input Rate (MBH) <sup>(1)</sup>		Heating Capacity (MBH) <sup>(1)(2)</sup>	Net I=B=R Rating (MBH) <sup>(1)</sup>	AFUE <sup>(2)</sup>	Flue Diameter	Shipping Wt.
High Fire	200	190	165	95%	2" CPVC & 3" PVC	284 lbs.
Low Fire	80	76	66			

<sup>(1)</sup> 1 MBH = 1,000 Btuh (British Thermal Units Per Hour)

<sup>(2)</sup> Heating Capacity and AFUE (Annual Fuel Utilization Efficiency) are based on DOE (Department of Energy) test procedures.

### 95M-200 HIGH ALTITUDE DERATE CHART

Boiler Input Rate (MBH)	Altitude (In Feet)							
	3,000	4,000	5,000	6,000	7,000	8,000	9,000	10,000
High Fire	196	192	188	184	181	177	174	170
Low Fire	78.4	76.8	75.3	73.8	72.3	70.9	69.5	68.1

### NATURAL GAS PIPING SIZES

Pipe Length	Pipe Capacity - BTU/Hr. Input Includes Fittings			
	1/2"	3/4"	1"	1 1/4"
20'	92,000	190,000	350,000	625,000
40'	63,000	130,000	245,000	445,000
60'	50,000	105,000	195,000	365,000

### LP GAS PIPING SIZES

Pipe Length	Pipe Capacity - BTU/Hr. Input Includes Fittings			
	Copper Tubing (O.D.)		Iron Pipe	
	5/8"	3/4"	1/2"	3/4"
20'	131,000	216,000	189,000	393,000
40'	90,000	145,000	129,000	267,000
60'	72,000	121,000	103,000	217,000

The length of pipe or tubing should be measured from the gas meter or propane second stage regulator.

### GAS SUPPLY PRESSURE

Natural Gas	4" min. w.c.	10" max. w.c.
LP Gas	10" min. w.c.	14" max. w.c.

Please check line pressure while unit is running.

### ROOF VENT / INTAKE TERMINATIONS

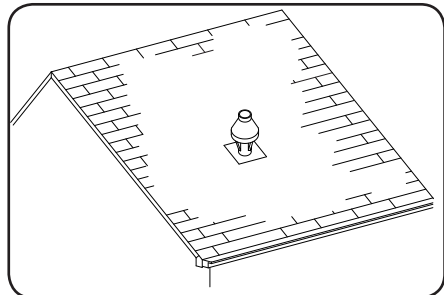
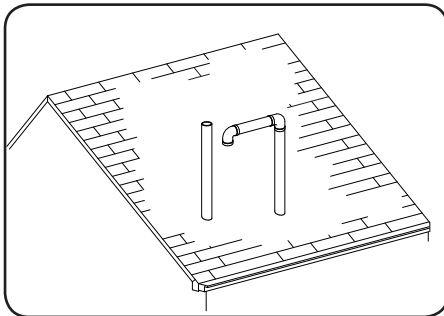

### SIDEWALL VENT / INTAKE TERMINATIONS

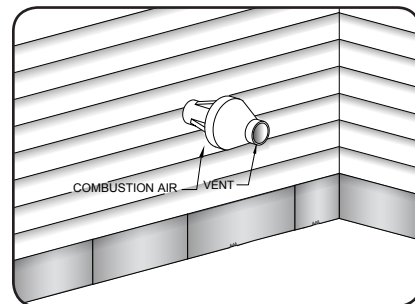
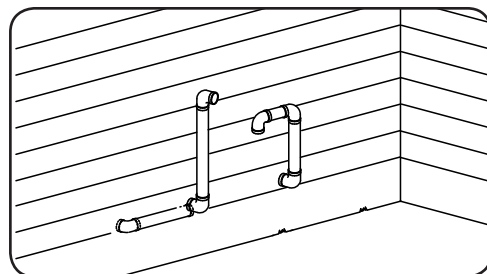

Note: See installation manual for proper dimensions & clearances of exhaust and air intake pipes and concentric terminations.

