



G95V
NATURAL AND PROPANE GAS TWO
STAGE HIGH EFFICIENCY (CONDENSING)
WARM AIR FURNACE

**INSTALLATION, OPERATION &
MAINTENANCE MANUAL**



An ISO 9001-2008 Certified Company

Manufactured by:

ECR International, Inc.
2201 Dwyer Avenue, Utica NY 13501
web site: www.ecrinternational.com

P/N 240006743, Rev. E [04/2012]

TABLE OF CONTENTS

1 - Warnings And Safety Symbols.....	3
2 - Furnace Dimensions And Clearance To Combustibles.....	6
3 - Installation Requirements	7
4 - Furnace Sizing.....	9
5 - Location Of Unit	10
6 - Combustible Clearances	12
7 - Duct Work.....	12
8 - Ventilation And Combustion Air.....	13
9 - Venting And Combustion Air Piping	14
10 - Non-Direct Vent Furnace Installations (Using Indoor Combustion Air)	15
11 - Determining Combustion Air.....	15
12 - Venting Guidelines	18
13 - Terminations	22
14 - Vent Clearances	26
15 - Vent And Draining Options - Upflow.....	29
16 - Condensate Drains	33
17 - Gas Supply And Piping	34
18 - Conversions.....	36
19 - Electrical Specifications.....	39
20 - Low Voltage Wiring	41
21 - Optional Accessories (Field Supplied/Installed).....	42
22 - Startup Procedures.....	42
23 - Air Flow.....	44
24 - Maintenance And Troubleshooting	47
25 - Troubleshooting Flowchart	50
26 - Diagnostic Codes For Status Led	51
27 - Wire Diagram For Two Stage Furnace With ECM.....	53
28 - Venting Checklist.....	54
29 - Replacement Parts List.....	55

PLEASE READ THIS MANUAL CAREFULLY AND KEEP IN A SAFE PLACE FOR FUTURE REFERENCE BY A SERVICE TECHNICIAN.

Introduction

This 95% efficient gas fired two stage condensing furnace is an upflow, downflow, horizontal left and right warm air furnace suitable for residential and light commercial heating applications from 60,000 to 120,000 BTU/Hr.

The 95% efficient furnace series is CSA design certified as a Category IV indirect or direct vent central forced air furnace. When installed as a direct vent furnace, all combustion air is supplied to the furnace burners through the air intake system. (See Section 8, "Ventilation and Combustion Air.")

All models may be fired by natural gas or LP gas (propane) and may be field converted from natural gas to LP gas.

The furnace is shipped completely assembled except for the drain trap assembly and the venting. Please inspect for damage when the furnace is unpacked.

IMPORTANT: Read the following instructions COMPLETELY before installing!!

1 - WARNINGS AND SAFETY SYMBOLS

The following defined symbols are used throughout this manual to notify the reader of potential hazards of varying risk levels.

	DANGER
Indicates an imminently hazardous situation which, if not avoided, WILL result in death, serious injury or substantial property damage.	

	CAUTION
Indicates an imminently hazardous situation which, if not avoided, may result in injury or property damage.	

	WARNING
Indicates an imminently hazardous situation which, if not avoided, may result in death, serious injury or substantial property damage.	

	NOTICE
Indicates information which should be followed to ensure proper installation and operation.	

WARNING

 If the information in these instructions is not followed exactly, a fire or explosion may result, causing property damage, personal injury or loss of life.

WARNING

 This product must be installed by a licensed plumber or gas fitter when installed within the commonwealth of Massachusetts.

WARNING

 These instructions are intended as an aid to qualified service personnel for proper installation, adjustment and operation of this furnace. Read these instructions thoroughly before attempting installation or operation. Failure to follow these instructions may result in improper installation, adjustment, service or maintenance, possibly resulting in fire, electrical shock, carbon monoxide poisoning, explosion, property damage, personal injury or death.

WARNING

FOR YOUR SAFETY

Do not store or use gasoline or other flammable vapors and liquids, or other combustible materials in the vicinity of this or any other appliance.

WHAT TO DO IF YOU SMELL GAS

Do not try to light any appliance.

Do not touch any electrical switch; do not use any phone in your building.

 Immediately call your gas supplier from a neighbor's phone, or a cellular phone from a location well away from the building. Follow the gas supplier's instructions.

If you cannot reach your gas supplier, call the fire department.

Do not re-enter the building until authorized to do so by the gas supplier or the fire department.

Improper installation, adjustment, alteration, service or maintenance can cause injury, property damage or loss of life. Refer to this manual.

Installation and service must be performed by a qualified installer, service agency or the gas supplier.

Safety Rules

1. Use this furnace only with type of gas approved for this furnace. Refer to the furnace rating plate.
2. Install this furnace only in dry indoor locations (protected from weather).
3. Provide adequate combustion and ventilation air to the furnace space as specified in Section 8 of this manual, "Ventilation and Combustion Air."
4. Combustion products must be discharged outdoors. Connect this furnace to an approved vent system only, as specified in Section 9 of this manual, "Venting and Combustion Air Piping."
5. Never test for gas leaks with an open flame. Use a commercially available soap solution made specifically for the detection of leaks to check all connections as specified in Section 17 of this manual, "Gas Supply and Piping."
6. Always install furnace to operate within the furnace's intended temperature-rise range with a duct system, which has an external static pressure within the allowable range, as specified in Sections 4, 7, and 23 of this manual, "Furnace Sizing," "Ductwork," and "Airflow."
7. When a furnace is installed so that the supply ducts carry air circulated by the furnace to areas outside the space containing the furnace, the return air shall also be handled by duct(s) sealed to the furnace casing and terminating outside the space containing the furnace. (Furnace for heating the home located in the attached garage, for example).
8. A gas-fired furnace for installation in a residential garage must be installed so that the burners and ignitor are no less than 18" above the floor. The furnace must be located, or protected to avoid physical damage by vehicles. (*See safety warning*).
9. This furnace is not be used for temporary heating for buildings under construction.

Codes

1. This furnace must be installed:
 - A. In accordance with all local codes, by-laws and regulations by those authorities having jurisdiction.
 - B. In Canada, this furnace must be installed in accordance with the current CAN/CGA -B149 Installation Code for Natural Gas and Propane Installations.
 - C. In the United States, this furnace must be installed in accordance with the current ANSI Z223.1 (NFPA 54) National Fuel Gas Code.
2. Electrical connections must be made in accordance with:
 - A. Any applicable local codes, by-laws and regulations.
 - B. Canada: current edition of CAN/CSA C22.1, Canadian Electrical Code (Part 1).
 - C. United States: current edition of ANSI/NFPA 70, National Electrical Code.

Codes and additional information may be obtained from:

Canadian Standards Association
 5060 Spectrum Way
 Mississauga, Ontario, L4W 5N6
 Phone: (416) 747-4000

American Gas Association
 400 North Capitol Street, NW, Suite 450
 Washington DC, 20001
 Phone: (202) 824-7000

National Fire Protection Association
 1 Batterymarch Park
 Quincy, MA, 02169-7471
 Phone: (617) 770-3000



WARNING

Do not install this furnace in a mobile home! This furnace is not approved for installation in a mobile home. Doing so could cause fire, property damage, personal injury or loss of life.



WARNING

THE FURNACE CONTAINS FOIL COVERED FIBER-GLASS INSULATION. Inhalation of fiberglass particles is associated with respiratory disease including cancer.



WARNING

Natural gas and propane are normally odorized by the fuel supplier. In some cases, the odorant may not be perceivable. Installation of UL and ULC recognized fuel gas detectors installed in accordance with their manufacturer's instructions is recommended as an additional margin of safety.



WARNING

The exhaust gases from this furnace contain chemicals which on some occasions may include carbon monoxide (CO). Carbon monoxide is an odorless, tasteless, clear colorless gas which is highly toxic. Even low concentrations are suspected of causing birth defects and other reproductive harm.

UL and ULC recognized CO detectors are recommended for all buildings equipped with fossil fuel burning appliances. All CO detectors should be installed in accordance with their manufacturer's instructions and applicable local building codes.



WARNING

When this furnace is installed in a residential garage, it must be installed so the burners and ignition source are located no less than 18" above the floor to prevent the risk of igniting flammable vapors which may be present in the garage.

The furnace must be located or protected to avoid physical damage by vehicles.

Failure to heed these warnings can cause a fire or explosion, resulting in property damage, personal injury or loss of life.

2 - FURNACE DIMENSIONS AND CLEARANCE TO COMBUSTIBLES

Figure 1 - Furnace Dimensions

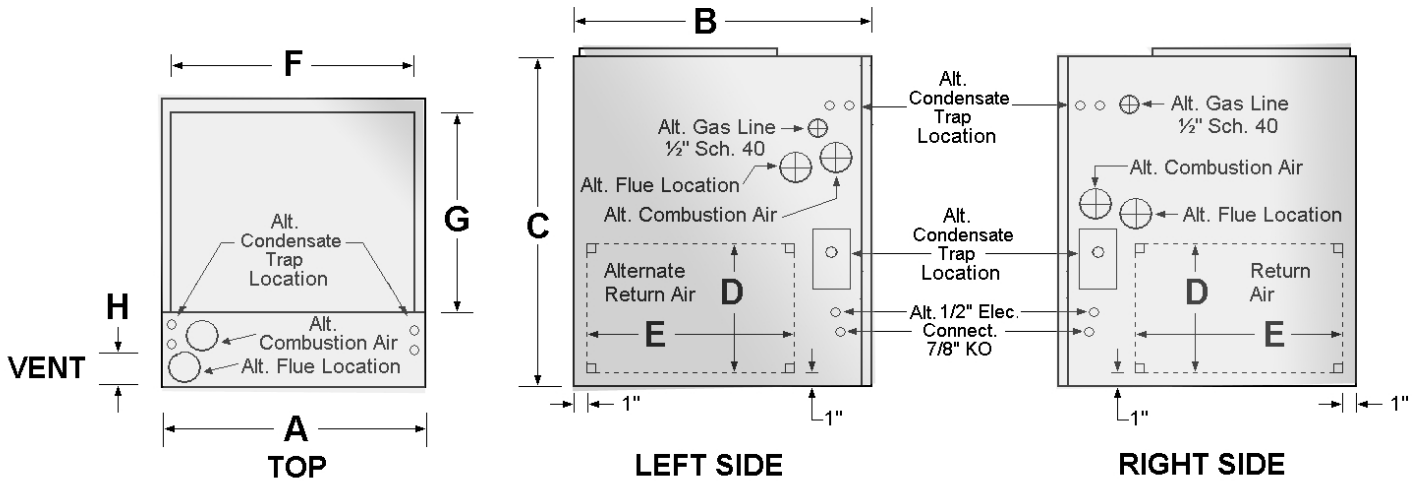

TABLE 1 - FURNACE DIMENSIONS

Model	Width A	Depth B	Height C	Vent H	Supply Air (F x G)
60	16 ⁷ / ₈ "	29"	40"	2"	15 ⁷ / ₈ " x 20"
80	18 ¹ / ₂ "	29"	40"	2"	17 ¹ / ₂ " x 20"
100	20 ¹ / ₂ "	29"	40"	2"	19 ¹ / ₂ " x 20"
120	23 ¹ / ₂ "	29"	40"	2"	22 ¹ / ₂ " x 20"

Figure 2 - Clearance To Combustibles

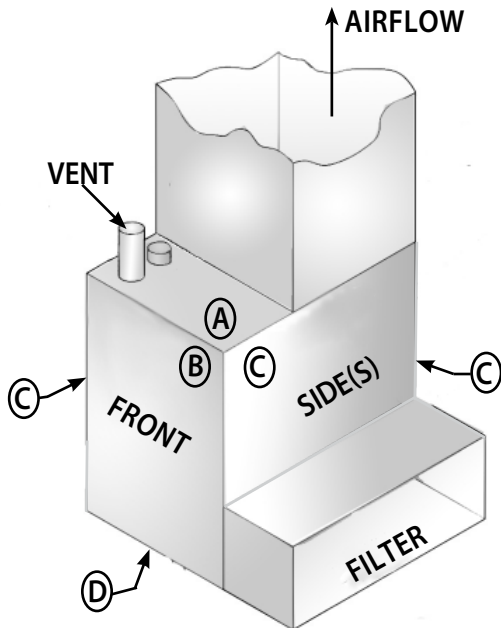

Table 2 - FURNACE CLEARANCE TO COMBUSTIBLES

SIDE	Distance
A	1" or Non-Combustible Floor
B	0", Service Clearance 24" or more
C	0"
D	Combustible Floor (must not be placed on carpet non-ceramic tile)
All models are approved for closet installation	

For downflow installations use optional sub-base kit 550001346

3 - INSTALLATION REQUIREMENTS

Installation Requirements Specific To The State Of Massachusetts For Direct Vent, Mechanical Vent, And Domestic Hot Water Appliances.

For all side wall horizontally vented gas fueled equipment installed in every dwelling, building or structure used in whole or in part for residential purposes, including those owned or operated by the commonwealth and where the side wall exhaust vent termination is less than seven feet above finished grade in the area of the venting, including but not limited to decks and porches, the following requirements shall be satisfied:

1. INSTALLATION OF CARBON MONOXIDE DETECTORS:

At the time of installation of the side wall horizontal vented gas fueled equipment, the installing plumber or gas fitter shall observe that a hard wired carbon monoxide detector with an alarm and battery back-up is installed on the floor level where the gas equipment is to be installed. In addition, the installing plumber or gas fitter shall observe that a battery operated or hard wired carbon monoxide detector with an alarm is installed on each additional level of the dwelling, building or structure served by the side wall horizontal vented gas fueled equipment. It shall be the responsibility of the property owner to secure the services of qualified licensed professionals for the installation of hard wired carbon monoxide detectors.

- A. In the event that the side wall horizontally vented gas fueled equipment is installed in a crawl space or an attic, the hard wired carbon monoxide detector with alarm and battery back-up may be installed on the next adjacent floor level.
- B. In the event that the requirements of this subdivision can not be met at the time of completion of installation, the owner shall have a period of thirty (30) days to comply with the above requirements; provided, however that during said thirty (30) day period, a battery operated carbon monoxide detector with an alarm shall be installed.

2. APPROVED CARBON MONOXIDE DETECTORS: Each carbon monoxide detector as required in accordance with the above provisions shall comply with NFPA 720 and be ANS/UL 2034 listed and IAS certified.

3. SIGNAGE: A metal or plastic identification plate shall be permanently mounted to the exterior of the building at a minimum height of eight (8) feet above grade directly in line with the exhaust vent terminal for the horizontally vented gas fueled heating appliance or equipment. The sign shall read, in print size no less than one-half (1/2) inch in size.

“GAS VENT DIRECTLY BELOW. KEEP CLEAR OF ALL OBSTRUCTIONS”.

4. INSPECTION: The state or local gas inspector of the side wall horizontally vented gas fueled equipment shall not approve the installation unless, upon inspection, the inspector observes carbon monoxide detectors and signage installed in accordance with the provisions of 248 CMR 5.0(2)(a)1. through 4.

5. EXEMPTIONS: The following equipment is exempt from 248 CMR 5.08(2)(a)1. through 4.:

- A. The equipment listed in Chapter 10 entitled “Equipment Not Required To Be Vented” in the most current edition of NFPA54 as adopted by the Board; and
- B. Product Approved side wall horizontally vented gas fueled equipment installed in a room or structure separate from the dwelling, building or structure used in whole or in part for residential purposes.

6. MANUFACTURER REQUIREMENTS -

A. GAS EQUIPMENT VENTING SYSTEM PROVIDED.

When the manufacturer of Product Approved side wall horizontally vented gas equipment provides a venting system design or venting system components with the equipment, the instructions provided by the manufacturer for installation of the equipment and the venting system shall include:

- Detailed instructions for the installation of the venting system design or the venting system components; and
- A complete parts list for the venting system design or venting system.

B. GAS EQUIPMENT VENTING SYSTEM NOT PROVIDED. When the manufacturer of a Product Approved side wall horizontally vented gas fueled equipment does not provide the parts for venting the flue gases, but Identifies “special venting systems”, the following requirements shall be satisfied by the manufacturer:

- The referenced “special venting system” instructions shall be included with the appliance or equipment installation instructions; and
- The “special venting systems” shall be Product Approved by the Board, and the instructions for that system shall include a parts list and detailed installation instructions.

7. INSTALLATION INSTRUCTIONS: A copy of all installation instructions for all product approved side wall horizontally vented gas fueled equipment, all venting instructions, all parts lists for venting instructions, and/or all venting design instructions shall remain with the appliance or equipment at the completion of the installation.

3 - INSTALLATION REQUIREMENTS

Figure 3 – Furnace Components

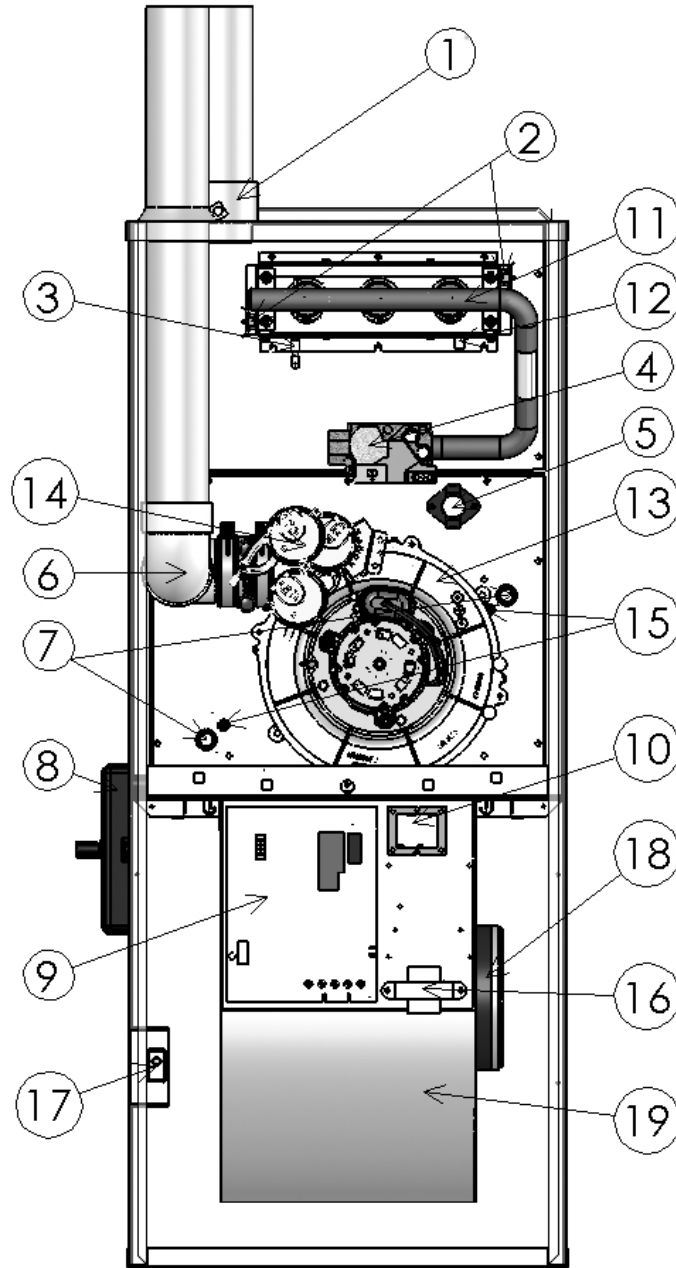

Item	Description	Qty	Item	Description	Qty
1	Combustion Air Intake Fitting	1	11	Burner Assembly	1
2	Flame Roll-out Switch	2	12	Igniter	1
3	Flame Sensor	1	13	Two Speed Induced Draft Blower	1
4	Two Stage Gas Valve	1	14	Pressure Switch Assembly	1
5	Air High Temperature Limit	1	15	Front Manifold Cover Pressure Tap	2
6	Vent and Drain Assembly	1	16	PFC "Choke Coil"	1
7	Drain for Recovery Coil	2	17	Door Switch and Junction Box	1
8	Condensate Trap	1	18	ECM Blower Motor	1
9	Two Stage Integrated Control Board	1	19	Blower	1
10	Transformer for 24 VAC	1			

Furnace Sizing

The maximum hourly heat loss for each heated space shall be calculated in accordance with the procedures described in the manuals of the Heating, Refrigeration and Air Conditioning Institute of Canada (HRAI), or by any other method which is suitable for local conditions, provided the results obtained are in substantial agreement with, and not less than those obtained using the procedure described in their manuals.

In the United States, “Manual J - Load Calculation,” published by the Air Conditioning Contractors of America, describes a suitable procedure for calculating the maximum hourly heat loss.

If the installation is a retrofit application, do not rely on the capacity of the existing heating equipment as a method to size the new furnace. Many of the heat transfer multiples listed in earlier versions of load calculation manuals were much higher than those listed in more recent editions. It is possible that energy saving measures have been completed since the installation of the existing furnace. This might include additional insulation in the attic or walls, the application of sprayed foam insulation, the addition of storm windows and doors, weather-stripping, caulking, etc.

Many of the older furnaces were equipped with large belt drive blower systems, operating at low RPM’s. If replacing an existing furnace, be sure that the existing ductwork can handle the amount of airflow necessary for a reasonable temperature rise. Most older gas furnaces operated with a system temperature rise of 70° - 100°F. This furnace is designed to be operated with a system temperature rise (ΔT) of High Fire 35° - 65°F, Low Fire 25° - 55°F. If the furnace selected has an identical output capacity as the original furnace, a substantial increase in system air flow will be required. See **Tables 3A and B** and the airflow characteristics in Section 23 of this manual, “Airflow.”

TABLE 3A - RANGE OF TEMPERATURE RISE

Furnace Model	Temperature Rise
60, 80, 100, 120	High Fire (HF) 35 - 65°F
	Low Fire (LF) 25 - 55°F

TABLE 3B - AIR FLOW FOR TEMPERATURE RISE

Furnace Model	High Fire (HF) CFM Required for a ΔT of F			
	35	45	55	65
60	1501	1167	955	808
80	2001	1557	1274	1078
100	2502	1946	1592	1347
120	3002	2335	1910	1616
Furnace Model	Low Fire (LF) CFM Required for a ΔT of F			
	25	35	45	55
60	901	700	573	485
80	1201	934	764	647
100	1501	1167	955	808
120	1801	1401	1146	970

Existing ductwork should be assessed for its air handling capabilities. For residential applications, the recommended air velocity of a supply air trunk duct is 700 feet per minute (fpm), and should not exceed 900 fpm. The recommended air velocity of a supply air branch run is 600 fpm, and should not exceed 900 fpm. These values are slightly lower for flexible ducting. The recommended air velocity of a return air trunk duct is 600 fpm, and should not exceed 700 fpm. The recommended and maximum air velocity of a return air branch 600 fpm.

The “Equal Friction Chart,” as published by ASHRAE and HRAI, is the basis for the various air duct calculators available through heating supply companies. Following the air velocity guide lines, according to the “Equal Friction Chart,” or a slide rule air duct calculator, a typical 6” round duct has a capacity of approximately 100 cfm.

NOTICE

The return air system is equally as important as the supply air system. An under-sized return air system will prevent sufficient quantities of air from reaching the supply air system and will consequently reduce the service life of the furnace and its components.

5 - LOCATION OF UNIT

1. General Guidelines

- A. Select a location where the exhaust and combustion air piping can be routed between the furnace and their terminations with a minimum of lengths and fittings. Be sure to check that the proposed termination location will meet code requirements with respect to location and minimum clearances. (See venting section for minimum and maximum limits.)
- B. Select a location as near as possible to the existing or proposed duct system.
- C. The furnace location must have provisions for condensate drainage. If a suitable drain is unavailable near the furnace, a condensate pump must be used. The condensate pump drain tubing must not terminate outdoors; similar to some air conditioning condensate installations. Be sure to select a condensate pump that has been approved for furnace condensate applications.
- D. The furnace location must permit access for servicing and be within the clearance to combustibles guidelines as marked on the appliance rating plate.
- E. The furnace must be installed level to allow for the proper drainage of condensate. The furnace may shut down during winter operation if the condensate does not drain freely away from the furnace.
- F. The furnace should be installed on a firm base when installed in the upflow position. This would typically be the concrete floor if installing the furnace in a basement.
- G. If the furnace is being installed so that the return air will enter through the bottom, the perimeter of the furnace must be properly supported.
- H. When installed in the horizontal position, the furnace may be supported from the bottom, or suspended. (Figure 3)
- I. If the furnace is to be installed in a commercial (repair) garage, the burners and ignition source must be a minimum of 4½ feet (1375 mm) above the floor. The furnace must be protected from physical damage by metal barriers or other acceptable means.

2. Other considerations

- A. If the furnace is to be located in an area where the combustion air is laden with chemical compounds such as bromine, chlorine or fluorine, as may be found in swimming pool chemicals, laundry detergents, etc., use outdoor air for combustion. These compounds when exposed to flame, form acids which attack the heat exchanger and other components. A partial list of contaminants would include:
 - Aerosols, particularly CFC based aerosols
 - Air fresheners
 - “Airplane” glue and similar cements
 - Ammonia, as is commonly found in permanent wave solutions used in women’s hair dressing salons
 - Anti-static fabric softeners used in clothes dryers
 - Carbon tetrachloride
 - Chlorinated cleaners and waxes
 - Chlorine and bromine based swimming pool chemicals and treatments
 - De-icing salts or chemicals, rock salt, etc.
 - Dry cleaning solutions such as perchloroethylene
 - Halogen based refrigerants including R-12 and R-22
 - Hydrochloric acid, muriatic acid, or other acid based masonry washing compounds
 - Polyurethane and similar derivatives fumes
 - Printer’s inks, paint removers, furniture strippers, varnishes, varsol, toluene, etc.
 - Water softener salts and chemicals

NOTICE

IMPORTANT: This furnace is not to be used for temporary heating of buildings or structures under construction.

Figure 4 - Suggested Method For Suspending Horizontal Furnace

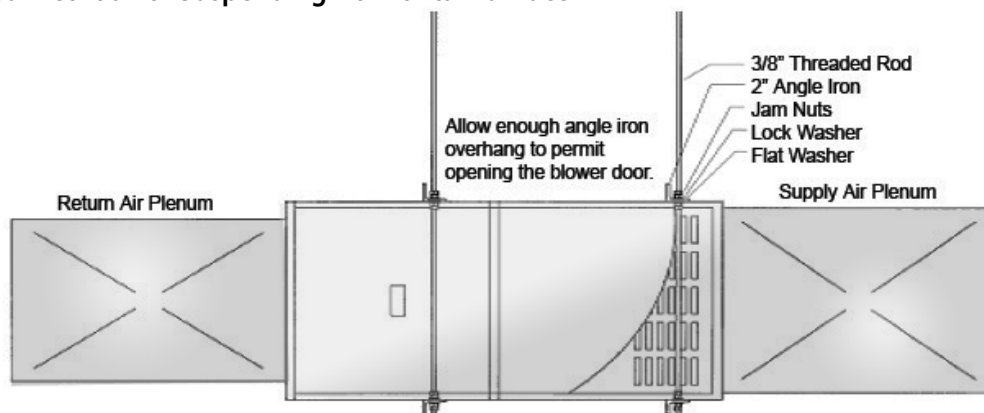

5 - LOCATION OF UNIT

- B. If this furnace is to be installed in an area over a finished ceiling or living area, install a field fabricated auxiliary drain pan under the furnace to protect that area from accidental condensate spills. The auxiliary pan should be large enough to collect accidentally spilled condensate from the air conditioning evaporator coil assembly if applicable.

NOTICE

These furnaces are approved for installation in attics, alcoves, utility rooms, closets and crawl spaces. If this furnace is to be installed in a utility room, be sure that it is located in such a way as to allow access for servicing or the removal of other appliances installed in the room (hot water heater, for example).

- C. If the furnace is installed in an area where freezing may occur, a garage, an attic, a crawl space or any unconditioned space, steps must be taken to protect the condensate trap and drain line from freezing. One possible measure could be to use a self-regulating 5 or 6 watt per foot heat tape covered with a jacket of insulation. Heat tapes are available in plumbing supply houses.

3. INSTALLATION IN UPFLOW, DOWNFLOW OR HORIZONTAL POSITIONS

- **UPFLOW INSTALLATION:** Vent positioning, pressure switch location and drain locations shall be performed in accordance with instructions in the appropriate sections of this manual.
- **HORIZONTAL INSTALLATION:** Vent positioning, pressure switch location and drain locations shall be performed in accordance with instructions in the appropriate sections of this manual.
- **NON-SUSPENDED INSTALLATION:** Maintain clearances to combustibles as outlined in **Figure 2, Table 2**. The furnace must be supported in such a way as to not allow twisting or sagging of the cabinet.
- **SUSPENDED INSTALLATION:** Maintain clearances to combustibles as outlined in **Figure 2, Table 2**. The furnace may be suspended by field fabricating a cradle of angle iron and threaded rod. Secure the furnace with 2" minimum slotted angle or equivalent as shown in **Figure 4**. The furnace must be supported in such a way as to not allow twisting or sagging of the cabinet. Position the supports so as to not interfere with accessing the burner and blower compartments.
- **DOWNFLOW INSTALLATION:** Vent positioning, pressure switch location and drain locations shall be performed in accordance with instructions in the appropriate sections of this manual.

The opening in the floor must provide adequate clearances to the combustible material. A ½" clearance will be required between the plenum and the combustible material. For sections of plenum with direct line of sight with heat exchanger, a 1" clearance will be required. If installed on a non combustible material, zero clearance is required. Optional subbase kit 550001346 will assist in achieving required clearances.

NOTICE

IMPORTANT: The rear of the furnace must be elevated 1/4" higher than the front from a level position to facilitate proper condensate drainage.

NOTICE

IMPORTANT: If the furnace and air conditioner is above a finished space, install a drain pan underneath the unit.

NOTICE

NOTE: It is not permissible to use a rear return on this appliance. Use only side and end returns.

4. **AIR CONDITIONING** This furnace may be used as part of an air conditioning system. The furnace wiring and control system is "air conditioning ready." There are the following factors to consider:

- The air conditioning evaporator coil must be downstream of the heat exchanger. The cooled air passing over the warmer heat exchanger tubes can cause condensation inside the tubes, resulting in corrosion and premature failure.
- A parallel duct system can be installed to direct the air from the furnace through the evaporator coil only. Use dampers or other means to bypass the heat exchanger. If (summer/winter) dampers are used, they should be interlocked to prevent system operation unless the dampers are in the full open or full closed position.

6 - COMBUSTIBLE CLEARANCES

Combustible Clearances

Figure 2, Table 2 provides the certified clearances to combustibles and dimensional information. Also see the appliance rating plate affixed to the furnace for specific model number, serial number and clearance to combustibles information.

NOTICE

IMPORTANT: This furnace requires a minimum of 24" of front clearance for service purposes. For this purpose, service clearance takes precedence over clearance to combustibles.

WARNING

This furnace is design certified for installation on combustible floors. This shall be interpreted as a wood floor only.

The furnace must not be installed directly on carpeting, tile, or other combustible material except wood.

Installation on combustible material can result in fire, causing property damage, personal injury or death.

WARNING

The area around the furnace must be kept clear and free of all combustible materials including gasoline and other flammable vapors and liquids.

The homeowner should be cautioned that the furnace area must not be used as a broom closet or for any other storage purpose.

Inspection / Access Panel

If an air conditioning coil is not to be used in the supply air plenum, it is recommended that the outlet duct be provided with a removable access panel which is accessible when installed so the heat exchanger may be inspected for possible openings using light assistance or a probe that can be inserted for sampling the air stream. The access cover must be fabricated in such a manner as to prevent leaks.

7 - DUCT WORK

Proper airflow is required for the correct operation of this furnace. Insufficient airflow may cause erratic operation, could cause the furnace to cycle on the high temperature limit, and may damage the heat exchanger. Excessive airflow may result in an excessively noisy duct system and may result in undesirable consequences such as creating uncomfortable drafts and causing drapes or curtains to blow around.

If air conditioning is to be used with the furnace, the duct system must be capable of delivering the correct amount of airflow for each system.

The ductwork should be sized and constructed in accordance with accepted industry standards. Duct sizing and construction information may be obtained from:

- A.C.C.A. (Air Conditioning Contractors of America)
- A.S.H.R.A.E. (American Society of Heating, Refrigeration and Air Conditioning Engineers)
- H.R.A.I. (Heating, Refrigerating and Air Conditioning Institute (Canada))
- S.M.A.C.N.A. (Sheet Metal and Air Conditioning Contractors' National Association (United States))

All of the above professional organizations have duct sizing manuals available.

The total static pressure drop of the air distribution system (including filters) should not exceed 1.0" w.c.

WARNING

Do not allow gas piping to be routed through joist spaces that are used for return air purposes. Do not use joist spaces for return air purposes if the joist space already contains plumbing stacks, chimney components, etc. Unless the portion used for return air purposes can be completely isolated from portions with other usages

WARNING

Failure to prevent products of combustion from being circulated into the living space can create potentially hazardous conditions, including carbon monoxide poisoning that could result in personal injury or death.

Do not, under any circumstances, connect return or supply air ductwork to or from any other heat producing device such as a fireplace insert, stove, etc. Doing so may result in fire, carbon monoxide poisoning, explosion, personal injury, loss of life, or property damage

7 - DUCTWORK

WARNING

Never allow the products of combustion from the flue to enter the return air or supply air ductwork.

All return air ductwork must be adequately sealed and secured to the furnace with sheet metal screws. Tape the sheet metal seams in the vicinity of the furnace with duct tape or similar material.

When the furnace is mounted on a platform with return air through the bottom, it must be sealed air tight between the furnace and the return air plenum. The floor or platform must provide sound physical support of the furnace without sagging, cracks or gaps around the base, providing a seal between the support and the base.

Models capable of 5 tons of airflow for air conditioning must have dual return air inlets for optimal airflow and air filtration. If not specifically stated by the filter manufacturer, for effective air filtration assume a maximum velocity of 300 FPM for disposable type filters or 600 FPM for permanent type air filters.

GUIDE: Filter free area (in²) = 144 x (CFM / desired velocity (FPM))

NOTICE

IMPORTANT: Some high efficiency filters have a greater than normal resistance to airflow. This can adversely affect furnace operation.

Ductwork Steps

WARNING

READ, UNDERSTAND AND FOLLOW ALL INSTRUCTIONS IN THIS SECTION. FAILURE TO PROPERLY VENT OR SUPPLY COMBUSTION AIR TO THIS FURNACE CAN CAUSE CARBON MONOXIDE POISONING, OR AN EXPLOSION OR FIRE, RESULTING IN PROPERTY DAMAGE, PERSONAL INJURY OR LOSS OF LIFE.

“*Vent and Chimney*” refer to open passageways that convey vent gases from the furnace, or its vent connector to the outside. Vents can be horizontal or vertical. When they serve only one gas appliance, they are called “dedicated” vents or chimneys. When they serve multiple gas appliances, they are called “common” vents or chimneys.

“*Vent Connector*” refers to a pipe or duct that connects the furnace

1. Position the furnace to minimize ductwork length and fittings.
2. Cut open a return air inlet. The choices are furnace bottom, either side, or any combination thereof (i.e., two sides or a side and the bottom).

WARNING



DO NOT USE THE REAR PANEL AS A RETURN AIR INLET. There is insufficient room to permit adequate airflow.

In all cases, cut the inlet air opening the full width of the knockouts.

3. Connect the return air duct or filter fitting to the furnace. The connection should be sealed air tight to prevent entraining combustion gases from an adjacent fuel burning appliance, or entraining combustion air for this furnace or adjacent fuel burning appliances.
4. Ensure that there is adequate space and accessibility for air filter removal.

NOTICE

NOTE: If two return air inlets are used, both must be equipped with filters.

5. If an air conditioning evaporator coil is required, position it on the supply air side of the furnace. Ensure that no air can bypass the evaporator coil.
6. Connect the supply air plenum to the supply air outlet.

Flexible duct connectors are an effective device to prevent the telegraphing of mechanical noise from the furnace to other parts of the home via the ductwork. If using flexible connectors, ensure that the adjoining duct is independently supported.

Definitions

8 - VENTILATION AND COMBUSTION AIR

to a vent or chimney. Vent connectors usually run from the furnaces vent collar to the vent or chimney. Vent connectors may have vertical and horizontal runs.

“*Venting System*” refers to a continuous open passageway from the vent collar to the outside. Venting systems usually have a vent connector(s) and a vent or chimney. Venting systems commonly serve a single furnace, or a single furnace and a hot water heater. Other multiple appliance venting systems are less common.

“*Fan Assisted Combustion System*” refers to an appliance equipped with an integral mechanical means to either draw or force products of combustion through the combustion chamber and/or heat exchanger. This series furnace uses a draft inducer to draw combustion products through the heat exchanger and is considered to have a fan-assisted combustion system. Category IV furnaces with fan-assisted

8 - VENTILATION AND COMBUSTION AIR

combustion systems must not be vented into single wall metal vents.

General Considerations

If this furnace is to replace a Category I type furnace connected to a chimney serving other appliances, steps must be taken to ensure that the remaining appliances will vent properly after the removal of the existing furnace. There is a probability that the existing chimney will be too large.

Remove the vent connector of the furnace being replaced, seal off the inlet to the vent from that furnace, then test the remaining appliances connected to the common vent individually following these steps:

1. Permanently seal any unused openings into the common vent system.
2. Visually inspect the venting system for proper size and horizontal pitch and determine that there is no blockage, restriction, leakage, corrosion, collapsed materials such as fallen bricks, or any other deficiency that could lead to an unsafe condition.
3. Insofar as practical, duplicate winter operating conditions such as closing all windows and doors in the building. If the remaining appliances are in a mechanical room, close the door to the room. Close the fireplace dampers if any, turn on any appli-

ances that exhaust air to the outdoors on maximum speed. This would include clothes dryers, range hoods, bathroom fans, etc. Attic fans or other fans used only in summer should be exempted from the test.

4. Follow the lighting instructions of the appliance being tested and turn it on to continuous operation.
5. Test for spillage at the draft hood relief opening after 5 minutes of main burner operation. Detect for spillage using a match flame, taper (candle).
6. After it has been proven that each appliance to remain connected to the common venting system properly vents when tested as listed above, return the windows, doors, fireplace dampers, appliances, etc. to the condition they were in prior to the test.
7. If improper venting is observed during any of the tests, the common venting system must be re-sized. In Canada, refer to the latest addition if CAN/GGA-B149, Natural Gas or Propane Installation Code. In the United States, refer to the latest ANSI Z223.1 National Fuel Gas Code (NEPA 54), or AGA-GAMA Venting Tables for Category I furnaces.

The furnace products of combustion include both flue gases and condensate. All venting and drain materials are plastic.

9 - VENTING AND COMBUSTION AIR PIPING

Acceptable Materials In The United States

For United States installations, the combustion air and vent piping and fittings may be comprised of:

- Schedule 40 PVC, ASTM D1785 or CSA B137.3
- PVC-DWV, ASTM D2665 or CSA B181.2
- Schedule 40 CPVC, ASTM F441 or CSA B137.6
- PVC PRIMER AND SOLVENT CEMENT: ASTM D2564

Follow piping manufacturers instructions on proper installation of piping and fittings including cutting, de-burring, priming, cementing, curing and supporting.

Acceptable Materials In Canada

Effective August 1, 2007, all vent piping materials and fittings for flue gas venting must be ULC S636 listed and identified as such on the material. The first 3ft. (900mm) of venting must be readily available for visual inspection. Specified primers and glues of the certified vent system must be from a single system manufacture, and not intermixed with other system manufacture's vent system parts. The components of the certified vent system must not be interchanged

with other vent systems, or unlisted pipe, and or fittings. Follow the venting manufacturers instructions on installation, cutting, de-burring, cementing, curing and supporting of the venting system.

This furnace can be vented with ULC S636 certified PVC material with a rating of 65° C or more.

The supplied PVC street elbows are certified for use within the vestibule. Use the approved transition cement certified by the ULC S636 venting supplier.

The optional Concentric Vent Termination Kits are certified for use. Use the approved transition cement certified by the ULC S636 venting supplier.

The combustion air piping does not have flue gases traveling through it and may be installed with common ABS, PVC or CPVC piping or fittings. This piping, fittings, primer and cement will need to be installed as per the manufacturers instructions including cementing, cutting, curing and supporting the piping.

10 - NON-DIRECT VENT FURNACE INSTALLATIONS (USING INDOOR COMBUSTION AIR)

The furnace, although designed as a direct vent type appliance, may be installed with the intake vent inside the structure.

WARNING



THIS FURNACE AND ANY OTHER FUEL BURNING APPLIANCE MUST BE PROVIDED WITH ENOUGH FRESH AIR FOR PROPER COMBUSTION AND VENTILATION OF THE FLUE GASES. MOST HOMES WILL REQUIRE THAT OUTSIDE AIR BE BROUGHT TO THE FURNACE AREA. FAILURE TO DO SO CAN CAUSE PERSONAL INJURY, OR DEATH FROM CARBON MONOXIDE POISONING.

Adequate provisions for combustion and ventilation air must be in accordance with CAN/CGA-B149 in Canada, and ANSI Z223.1 - 1992, section 5.3, "Air for Combustion and Ventilation," in the United States. Check with local authorities for any additional building codes bylaws or regulations.

CAUTION



Air for combustion and ventilation purposes must not originate from a corrosive atmosphere. Any furnace failure caused by corrosive elements is excluded from warranty coverage.

The following types of installation sites (but not limited to the following) will REQUIRE OUTDOOR AIR for combustion because of chemical exposures:

- Commercial buildings
- Buildings with indoor swimming pools
- Furnaces installed in laundry rooms
- Furnaces in hobby or craft rooms
- Furnaces installed near chemical storage areas

Exposure to the following substances in the combustion air supply (but not limited to the following) will also require OUTDOOR AIR for combustion:

- Aerosols, particularly CFC based or propelled aerosols
- Air fresheners
- "Airplane Glue" and similar adhesives and cements
- Ammonia, as commonly found in permanent wave solutions used in hair dressing salons
- Anti-static fabric softeners used in clothes dryers
- Carbon tetrachloride
- Chlorinated cleaners and waxes
- Chlorine and bromine based swimming pool chemicals
- De-icing salts or chemicals (rock salt, etc.)
- Dry cleaning fluids such as perchloroethylene
- Fumes from curing polyurethane and similar substances
- Halogen based refrigerants including R-12 and R-22
- Hydrochloric acid, muriatic acid and other acid based masonry washing and curing materials
- Printer's inks, paint removers, varnishes, varsol, toluene, etc.
- Water softener salt and chemicals

Combustion air must be free of acid forming chemicals such as sulphur, fluorine and chlorine. These elements are found in aerosol sprays, detergents, bleaches, cleaning solvents, air fresheners, paint and varnish removers, refrigerants, and many other commercial and household products. When burned in a gas flame, vapors from these products form acid compounds. Acid compounds increase the dew point temperature of the flue products and are highly corrosive after they condense.

11 - DETERMINING COMBUSTION AIR

CASE 1 - Furnace Located In An Unconfined Space

Unconfined space does not necessarily mean that ventilation will not have to be introduced from the outdoors, particularly in airtight homes. The minimum requirement for unconfined space is a volume of 50 cubic feet for each 1000 BTU/Hr for all fuel burning appliances located within the unconfined area.

If the amount of combustion and ventilation air is insufficient to properly operate the furnace and other fuel burning appliances within the unconfined area, it will be necessary to supply it from the outdoors based on the criteria used when calculating the air supply for a confined space.

NOTICE

NOTE: If planning to use the inside air in an unconfined space, remember to test for proper furnace operation (as well as other fuel burning appliances located within the unconfined space) with respect to adequate combustion and ventilation air with fireplace dampers open, clothes dryer running, bathroom exhaust fans on, kitchen range hood on, etc.

CASE 2 - Furnace Located In A Confined Space

A confined space, (any space smaller than the minimums discussed

in Case 1), must have two air openings; one within 12” of the ceiling and the other within 12” of the floor. The air openings must be sized based on whether the combustion and ventilation air is being taken from indoors or outdoors, the method outdoor air (if used) is introduced, and taking into account any other fuel burning appliances in the confined space.

If sufficient indoor combustion and ventilation air is available for the furnace and all other fuel burning appliances, size each opening on the basis of one square inch of free area per 1000 BTU/Hr. (**Figure 5**)

NOTICE

NOTE: Be sure to consider all clothes dryers, bathroom fans, range hoods, etc., when making this calculation.

Figure 5 - Combustion/Dilution Air From Heated Inside Sources (Case 2)

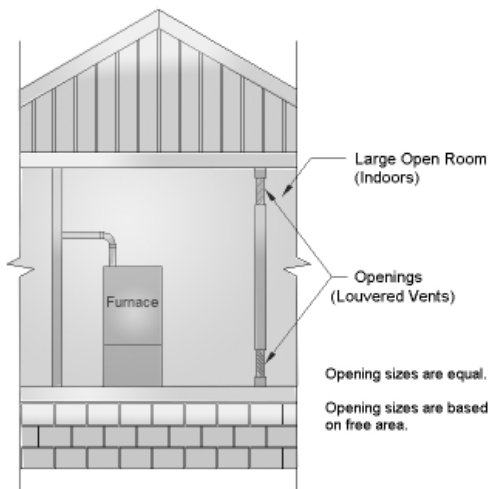

The minimum requirement for these openings is 100 square inches, even for the furnace models under 100,000 BTU/Hr.

NOTICE

NOTE: If using grilles to cover the two openings, factor in the free area of the grille. Typically, a sidewall grille will have a free area approximately 50% of its nominal size. Consequently, if the required opening is 10 x 10, it will have to be doubled if using a sidewall grille with 50% free area.

NOTICE

IMPORTANT: If an exhaust fan, fireplace, clothes dryer or any similar device is present in the indoor area from which the combustion and ventilation air will be drawn, negative pressure could be a problem if natural infiltration from the outdoors does not match the rate at which air is exhausted.

CASE 3 - Furnace Located In A Confined Space, Outdoor Air From Attic Or Crawl Space

In this circumstance, the free area of each of the two combustion and ventilation air openings is based on a minimum of 1 square inch per 4000 BTU/Hr. In this configuration, one opening can originate from the floor drawing combustion and ventilation air from the ventilated crawl space.

The other opening may communicate freely with a ventilated the attic. If using the attic air, ensure that the opening is ducted from the ceiling high enough to be above the insulation. The attic must be adequately vented with soffit vents or gable vents. (**Figure 6**)

Figure 6 - Outside Air For Combustion, Attic Or Crawl Space (Case 3)

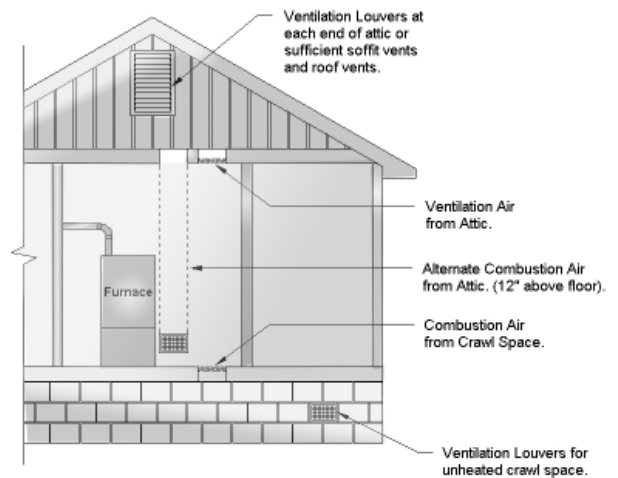

As an alternative to creating an opening in the floor to draw air from a crawl space, a duct may be dropped from the attic terminating 12” above the floor.

The following table (**Table 4**) shows minimum free areas and round pipe sizes when drawing combustion air vertically from the attic or crawl space for the furnace only. If other fuel burning appliances are present, their combustion air and ventilation air requirements must be added to those of the furnace.

TABLE 4 - VERTICAL AIR SUPPLY (CASE 3)

Model	Free Area Ea. Opening	Round Pipe Size
60	15 in. ²	5 in.
80	20 in. ²	6 in.
100	25 in. ²	6 in.
120	30 in. ²	7 in.

NOTICE

IMPORTANT: If the attic has an exhaust fan (power vent), it may create a negative pressure sufficiently large enough to prevent the attic from being an effective source of combustion and ventilation air. Powered attic fans do not customarily run during the heating season; however, some are controlled by a humidistat as well as a thermostat, which may allow some operation during the heating season. The choices are (a) use the direct vent option; (b) obtain outdoor air from elsewhere; or (c) interlock the attic exhaust fan with the furnace such that the two cannot operate simultaneously.

Figure 7 - Outdoor Air For Combustion, Horizontal (Case 4)

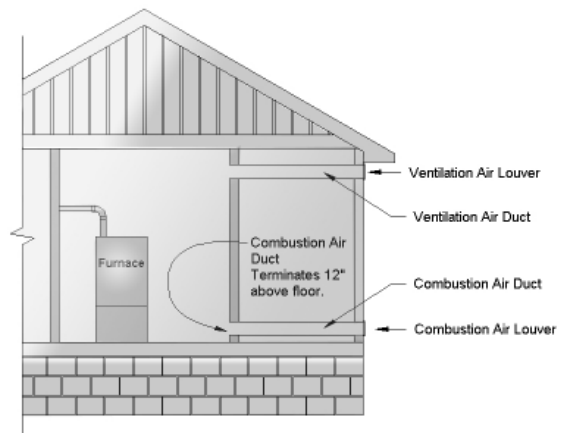

CASE 4 - Furnace Located In A Confined Space, Outdoor Air Ducted Horizontally

Similar to Case 3, outdoor air for combustion and ventilation may be drawn through horizontal ducting. The free area for each opening is calculated on the basis of a minimum of 1 square inch per 2000 BTU/Hr input.

The following table shows minimum free areas and round pipe sizes when drawing combustion air horizontally from the outdoors for the furnace only. If other fuel burning appliances are present, their combustion air and ventilation air requirements must be added to those of the furnace.

TABLE 5 - HORIZONTAL AIR SUPPLY (CASE 4)

Model	Free Area Ea. Opening	Round Pipe Size
60	30 in. ²	7 in.
80	40 in. ²	8 in.
100	50 in. ²	8 in.
120	60 in. ²	9 in.

NOTICE

IMPORTANT: If grilles are used on the outside wall, they must be sized properly. Most sidewall grilles have only 50% free area. In the case of a unit with 100,000 Btuh input, which requires a pair of 8” round pipes to obtain sufficient combustion and ventilation air, the duct could be an equivalent rectangular duct; 8” x 7” for example. Based on 50% free area for the inlet grilles, the actual grille size would have to be 14” x 8” or its equivalent. A transition may be used to reduce to the smaller duct size if necessary.

NOTICE

IMPORTANT: The outdoor grilles must be installed in a location where they will not be obstructed in any manner.

CASE 5 - Furnace Located In A Confined space, Outdoor Air Ducted with Single Opening (US Only)

One permanent opening, commencing within 12 in. (300 mm) of the top of the enclosure, shall be provided. The appliance shall have clearances of at least 1 in. (25 mm) from the sides and back and 6 in. (150 mm) from the front of the appliance. The opening shall directly communicate with the outdoors or shall communicate through a vertical or horizontal duct to the outdoors or spaces that freely communicate with the outdoors and shall have a minimum free area of the following:

- 1 in²/3000 BTU/hr (700 mm² per kW) of the total input rating of all appliances located in the enclosure, and
- Not less than the sum of the areas of all vent connectors in that space”

Connection To Furnace Non-Direct Vent

When using indoor air or the non-direct vent configuration, the combustion air inlet to the furnace must be protected from block-age. Use a double elbow arrangement if supplying combustion air through the top, or a downward pointing single elbow if supplying combustion air through the side. (Figure 8)

Figure 8- Non-Direct Combustion Air Inlet

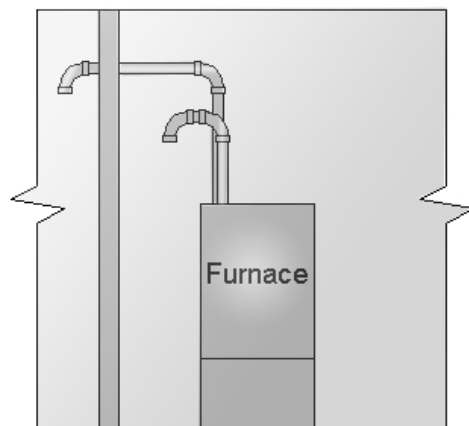

12 - VENTING GUIDELINES

CAUTION



Failure to follow all venting guidelines may result in erratic furnace operation, freeze-up of the exhaust air piping, or sooting of the furnace.

WARNING



READ AND FOLLOW ALL INSTRUCTIONS IN THIS SECTION. FAILURE TO PROPERLY VENT THIS FURNACE CAN CAUSE CARBON MONOXIDE POISONING OR AN EXPLOSION OR FIRE RESULTING IN PROPERTY DAMAGE, PERSONAL INJURY OR LOSS OF LIFE.

NOTICE

NOTE: Combustion air intake and exhaust termination should be inspected periodically to ensure they are clear of obstructions. i.e. vegetation, debris, snow, etc.

NOTICE

NOTE: Accumulation of snow around the combustion air intake and exhaust termination may have negative effects on appliance operation and/or performance. Snow accumulation should be considered when locating combustion air intake and exhaust terminations.

- Venting may be vertical or horizontal.
- Minimum vent length - 25 total equivalent feet. (See **Venting Table 6**)
- Horizontal piping must slope back towards the furnace at a minimum rate of $\frac{1}{4}$ " to the foot, so that condensate drains towards the furnace.
- Horizontal runs must be supported at least every 3 feet. Horizontal sections must not dip or sag.
- All vent runs through unconditioned space where freezing might occur should be insulated with 1" thick, medium density, foil-faced Fiberglass insulation. An equivalent "arm-a-flex" or "rub-a-tex" may also be used as long as there is no heat tape applied to the vent pipe. For horizontal runs where water may collect, wrap the vent pipe with self regulating 3 or 5 watt heat tape. The heat tape must be CSA, UL, or ULC listed and installed per the manufacturer's instructions.
- DO NOT COMMON VENT WITH ANY OTHER APPLIANCE.

- If venting vertically, do not vent up a chimney serving another appliance or install in a chase with a metal or high temperature plastic pipe from another gas or fuel burning appliance unless the required clearances to combustibles can be maintained between the furnace venting system and other pipes.

All exhaust piping must be installed in accordance with CAN/CGA-B149 in Canada; the latest edition of National Fuel Gas Code, NFPA 54 / ANSI Z223.1 in the United States, as well as in accordance with local codes.

Size the combustion air and exhaust piping in accordance with **Table 6**. When calculating allowable vent lengths, be sure to count all termination fittings in addition to counting the concentric vent as a straight pipe.

Take the building orientation and the presence of other buildings or other nearby structures into consideration when planning the venting system location. Certain external structures could create air turbulence around the vent termination leading to downdrafts and similar venting problems. In windy and hill locations, roof venting may improve operations. Maximum venting length is based on 30 mph winds, areas where higher gusts are dominant it is suggested to shorten the horizontal vent length.

The vent and combustion air intake shall be installed so that both are located in the same wind pressure zone.

WARNING



DO NOT CONNECT FURNACE TO A CHIMNEY OR FLUE SERVING OTHER APPLIANCES OR A SOLID FUEL BURNING APPLIANCE.

Vent Termination

Horizontal vents should pass through the exterior wall. **Figure 9** shows a standard horizontal vent detail. Terminate the vent approximately 8" or more from the wall.

Figure 9 - Standard (Straight) Horizontal Vent Detail

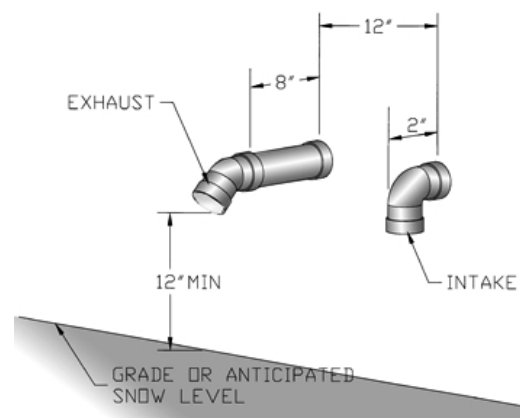

TABLE 6 - DIRECT AND NON-DIRECT VENT LENGTHS
 MAXIMUM ALLOWABLE LENGTH OF EXHAUST OR INTAKE

MODEL	PIPE SIZE	NUMBER OF 90° ELBOWS							NOTES
		0	1	2	3	4	5	6	
60	1½"	25	20	15	10	5	-	-	1. Count concentric vent fitting as straight pipe. 2. Use medium or long sweep elbows where possible. 3. One 90° elbow is equivalent to two 45° elbows. 4. For direct vent, the listed lengths are allowed for each vent (intake and exhaust). 5. For non-direct vent, the listed lengths are allowed for exhaust. The intake should have a 1½" or 2" snorkel intake fitting. (Figure 9) 6. Include the 2 vestibule elbows when calculating total vent length for all models.
	2"	75	70	65	60	55	50	45	
	3"	100	95	90	85	80	75	70	
80	2"	50	45	40	35	30	25	20	
	3"	100	95	90	85	80	75	70	
100	2"	50	45	40	35	30	25	20	
	3"	100	95	90	85	80	75	70	
120	3"	100	95	90	85	80	75	70	

When 1½" or 3" pipe is used, exit the cabinet with 2" pipe. Reduce or increase immediately after exiting the cabinet making provisions to secure the vent bracket between cabinet and fitting.
 Use of a concentric termination reduces the allowable length by 5 feet from lengths shown in this table.

Figure 11 - Vertical Venting

Figure 10 - Periscoped Vent Detail

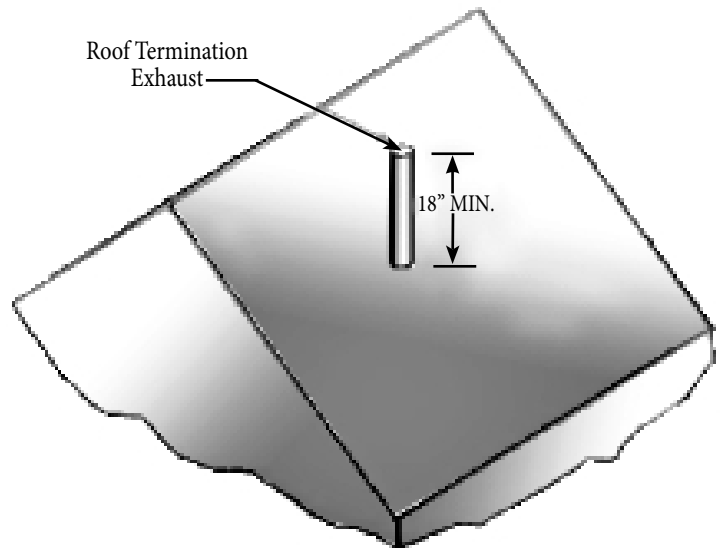
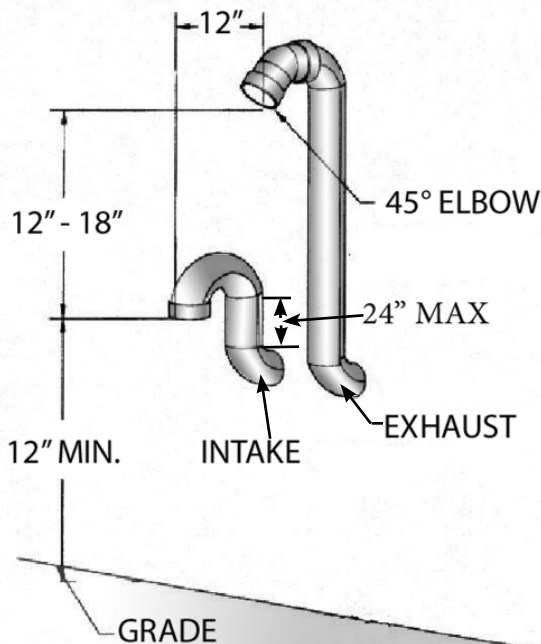

12 - VENTING GUIDELINES

If it is not possible to obtain proper clearance to grade by a straight out configuration, the termination may be raised by the use of a pair of 90° elbows. (**Figure 9**, Exhaust Detail Only)

NOTICE

NOTE: Length of pipe and elbows count toward maximum allowable vent length as shown in Table 6.

Besides the initial increaser/reducer, the venting system must stay consistent in regards to pipe diameter through out the entire vent length. The vent may also terminate in a vertical venting configuration through the roof. No termination fitting is required.

The exhaust pipe extending through the roof must extend 18" above the highest point where it extends through the roof, surface and above any obstruction within an 18" horizontal distance. (**Figure 11**)

Exterior vent pipe greater than 24" should be insulated with ½" insulation to prevent moisture from freezing within the pipe and accumulating.

Size the exhaust pipe as specified in **Table 6** - Direct and Non-Direct Vent Lengths. This table lists the maximum allowable length of pipe with respect to the number of 90° elbows used. For the purposes of this calculation, one 90° elbow is equivalent to two 45° elbows.

Avoid locating the terminal in locations where dripping condensate may cause problems such as sidewalks, patios, above planters, near windows where exhaust gases may cause fogging, etc. Avoid locating the termination too close to shrubs and other vegetation. The condensate may stunt or kill them.

CAUTION



Moisture in the flue gases condenses as it leaves the terminal. This moisture can freeze on exterior walls, on soffits, and other nearby objects. Some discoloration is to be expected; however, improper location or installation can cause structural or exterior finish damage to the building.

Caulk all cracks, seams or joints within a 6 foot radius of the termination.

Do not terminate under a deck unless there is adequate clearance to prevent damage from the flue gases. A termination may be located at the end of a patio deck. Piping running beneath the deck must be suitably insulated and suspended in a manner to prevent condensate from collecting and freezing.

Do not locate the terminal on the side of the building facing the prevailing winter winds.

In Canada

In addition to the general guidelines, in Canada, the non-direct vent exhaust shall not terminate:

- Directly above a paved sidewalk or paved driveway which is located between two single-family dwellings and serves both dwellings;
- Less than 7 feet above a paved sidewalk or paved driveway located on public property;
- Within 6 feet of a mechanical air supply inlet to any building;
- Above a meter/regulator assembly within 3 feet horizontally of the centerline of the regulator;
- Within 6 feet of any service regulator vent outlet;
- Less than 12" above grade level or anticipated snow level;
- Within 12" of any door, window, or non-mechanical air supply inlet to any building;
- Within 12" of the combustion air inlet of any other appliance;
- Underneath a veranda, porch or deck, unless (a) the veranda, porch or deck is fully open on a minimum of two sides beneath the floor, and (b) the distance between the top of the vent termination and the underside of the veranda, porch or deck is greater than 12".

In The U.S.A.

In addition to the general guidelines, in the United States, the non-direct vent exhaust shall be installed in accordance with the following:

- The clearance from the bottom of the terminal to grade shall be 12".
- The vent shall not terminate over public walkways or over an area where condensate or vapor could create a nuisance or hazard.
- The vent terminal shall be installed 4 feet below, 4 feet horizontally from, or 1 foot above any door, window, soffit, under eave vent or gravity air inlet to the building.
- The vent terminal shall have a minimum horizontal clearance of 4 feet from electric meters, gas meters, regulators and relief equipment.
- Locate the vent terminal 3 feet above any forced air inlet located within 10 feet. Any fresh air or make-up air inlet, such as for a dryer or furnace area is considered a forced air inlet.

The vent terminal should be located no fewer than 6 feet from an inside corner formed by two exterior walls; a 10 foot distance is recommended.

Recommended clearance from overhangs is a minimum of 1 foot vertically for each foot horizontally up to 6 feet.

Furnace Venting Installations

WARNING



READ AND FOLLOW ALL INSTRUCTIONS IN THIS SECTION. FAILURE TO PROPERLY VENT THIS FURNACE CAN CAUSE CARBON MONOXIDE POISONING OR AN EXPLOSION OR FIRE RESULTING IN PROPERTY DAMAGE, PERSONAL INJURY OR LOSS OF LIFE.

Non-Direct Vent Installation (Using Indoor Combustion Air)

Non-direct vent installations require only a vent pipe. This may be desirable when using outdoor combustion air is not practical.

- Provisions are not made for routing of combustion air;
- The outdoor environment may contain contaminants undesirable for combustion.

Direct Vent Installation (Using Outdoor Combustion Air)

The direct vent configuration is the preferred installation method. The primary advantages are:

- No special kit or modifications are required for direct vent installations
- Dedicated combustion air and vent piping eliminates the need to use already heated air for combustion purposes;
- The probability of corrosive contaminants being present in the combustion air is greatly reduced;
- The direct vent configuration is unaffected by any other appliances, exhaust fans, or other devices that tend to create negative pressure conditions while operating.
- No vents for combustion and ventilation air are required in confined spaces

Combustion Air

This furnace is certified as a Category IV Type FSP Non-Direct and Direct Vent Furnace. When installed as a direct vent furnace, all combustion air is supplied from the outdoors via the plastic piping system. All components are field supplied except for the adapter used to connect the piping to the furnace.

The combustion air piping, like the exhaust piping, must be air tight throughout the system. The adapter joining the combustion air to the furnace is supplied with a gasket to maintain the seal.

NOTICE

IMPORTANT: The supplied adapter is made of PVC. If planning to use ABS pipe, use an all-purpose cleaner and ABS to PVC transition cement. If planning to use CPVC pipe, use an all-purpose cleaner, a clear or purple primer and all-purpose cement approved for the purpose.

Additional information about cleaners, primers, solvents and cements may be obtained from their manufacturers.

NOTICE

IMPORTANT: If the furnace is to be installed in the vicinity of other fuel burning appliances, adequate combustion air must be available for the non-direct vent appliances. See Section 11 of this manual, "Determining Combustion Air."

Combustion Air

HORIZONTAL - The combustion air termination is made up of a medium or long sweep 90° elbow pointing downward to prevent rain from readily entering the combustion air intake piping. An intake screening is optional; however, unless there is a compelling reason to use one, the screen may actually encourage the formation of rime ice, which could cause the intake to become blocked in certain weather conditions.

If the required clearance to grade cannot be obtained with the “straight through” configuration, the combustion air intake pipe may be “periscoped” up to 24” to gain extra height (**Figure 10**)

VERTICAL - The combustion air termination is made up of a pair of medium or long sweep 90° elbow pointing downward to prevent rain from entering the combustion air intake piping. The termination inlet must be positioned within 3” of the companion exhaust piping.

The combustion air inlet must be located a minimum of 12” above grade, and 12” below the exhaust outlet. (**Figure 12**)

Figure 12 - Standard Vertical Venting Detail

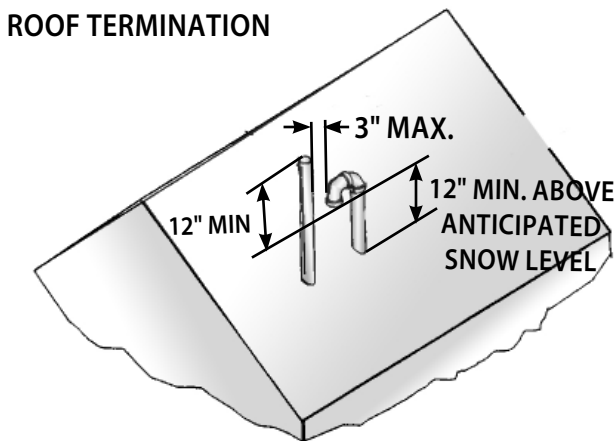

Exhaust

HORIZONTAL - The exhaust termination is normally a 45° elbow or a medium or long sweep 90° elbow pointing within 45° of the downward position, away from the combustion air intake terminal.

If the required clearance to grade cannot be obtained with the “straight through” configuration, the exhaust pipe may be “periscoped” up to 24” to gain extra height. (**Figure 10**) In this case, the flue gases may be expelled horizontally. Use the same size pipe as the interior run and count the fittings and length as part of the total vent length.

If winter prevailing wind conditions are variable and likely to occasionally blow flue gases back in on the combustion air intake, the exhaust termination may be raised 18-24” above the combustion air

intake terminal to take advantage of the natural buoyancy of the flue gases to help prevent re-circulation of the exhaust. (**Figure 10**)

VERTICAL - No termination fitting is required if venting vertically through a roof. The end of the exhaust pipe must be 12” higher than the entrance of the combustion air intake terminal. (**Figure 12**)

The exhaust pipe extending through the roof must extend a minimum of 18” above any obstruction within an 18” horizontal distance.

Concentric Venting Kit

Concentric venting terminal kits may be used for this series furnace. They provide a means of obtaining combustion air and exhausting products of combustion utilizing a single penetration through the exterior wall. This can be useful when there is limited wall space available. Kits are available in 2” and 3” sizes. If venting the 60000 Btuh model with 1½” vent material, and a concentric vent kit is necessary, a increase coupling may be used to connect to the 2” concentric venting kit. Read the instructions supplied with the kit for additional installation instructions and details.

Concentric Vent Termination Installation Instructions

Follow the concentric vent termination manufactures instructions for installation of the concentric vent termination kit. These instructions can be found by contacting the furnace manufacture. Furnace manufacture contact information is found on the front cover of this installation manual and operating instructions.

Location

Avoid locating the terminals where the flue gas could become stagnant and allow recirculation into the combustion air intake.

Avoid locating the terminal in locations where dripping condensate may cause problems such as sidewalks, patios, above planters, near windows where exhaust gases may cause fogging, etc.

Avoid locating the termination too close to shrubs and other vegetation. The condensate may stunt or kill them.

Caulk all cracks, seams or joints within a 6 foot radius of the termination.

Do not terminate under a deck unless there is adequate clearance to prevent damage from the flue gases. A termination may be located at the end of a patio deck. Piping running beneath the deck must be suitably insulated and suspended in a manner to prevent condensate

from collecting and freezing.

Do not locate the terminal on the side of the building facing the prevailing winter winds.

CAUTION

Improper location or installation can result in structural damage to the building, damage to the exterior finish of the building, or may allow recirculation or freezing of the flue gases onto or into the combustion air intake.

Moisture in the flue gases condenses as it leaves the terminals. This moisture can freeze on exterior walls, soffits, and other nearby objects. Some discoloration is to be expected.

The vent terminal should be located no fewer than 6 feet from an inside corner formed by two exterior walls. A 10 foot distance is recommended.

Recommended clearance for overhangs is a minimum of 1 foot vertically for each foot horizontally up to 6 feet.

As a protection against freezing, do not expose a 3" x 2" reducing coupling to outdoor ambient temperatures.

Any adjacent painted surfaces should be in good condition; no cracks, peeling paint, etc. If wooden surfaces that may be periodically exposed to flue gases are present, consider treating with a sealer such as Thompson's Water Seal®. Additional information about sealers may be obtained from the Thompson's web site at www.thompsonsonline.com.

Multiple Venting

NOTICE

IMPORTANT: When installing multiple furnaces in close proximity, each requires dedicated combustion air and exhaust venting.

COMMON VENTING IS PROHIBITED!!

If two of these furnaces are to be installed in close proximity, the combustion air intake and exhaust terminations may be installed as shown in **Figures 13 and 14**.

Figure 13 - Multiple Venting (Standard Horizontal)

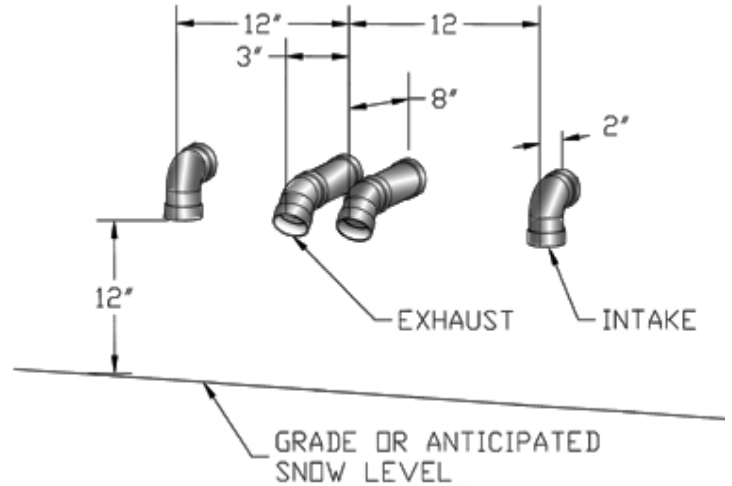
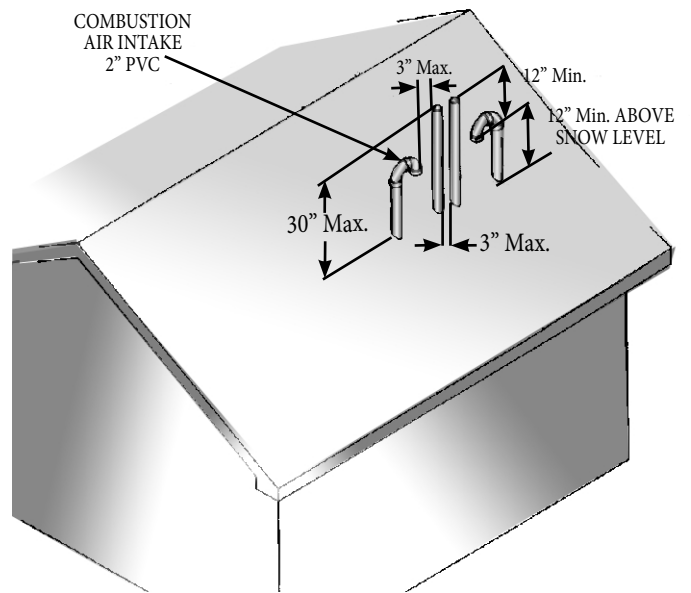

Figure 14 - Multiple Venting (Standard Vertical)



If more than two furnaces are being installed in close proximity, each additional combustion air intake and exhaust termination set shall not terminate less than 12 in (300 mm) apart.

Note: Canadian installations of 120000 Btuh require 3 ft (900 mm).

WARNING



Recirculation of flue gases may occur causing the intake pipe to freeze shut during cold weather operation if the venting system is not installed per these guidelines.

In Canada

In addition to the general guidelines, both non-direct and direct vent exhaust shall not terminate:

- Directly above a paved sidewalk or paved driveway which is located between two single-family dwellings and serves both dwellings;
- Less than 7 feet above a paved sidewalk or paved driveway located on public property;
- Within 6 feet of a mechanical air supply inlet to any building;
- Above a meter/regulator assembly within 3 feet horizontally of the centerline of the regulator;
- Within 6 feet of any service regulator vent outlet;
- Less than 12" above grade level or anticipated snow level;
- Within 12" of any door, window, or non-mechanical air supply inlet to any building;
- Within 12" of the combustion air inlet of any other appliance;
Note: Canadian installations of 120,000 BTU/h requires 3 ft. (900 mm)
- Underneath a veranda, porch or deck, unless (a) the veranda, porch or deck is fully open on a minimum of two sides beneath the floor, and (b) the distance between the top of the vent termination and the underside of the veranda, porch or deck is greater than 12".
- Refer to Figures **17A and 17B** for terminal clearances.

In The U.S.A.

In addition to the general guidelines, in the United States, both non-direct and direct vent exhaust shall be installed in accordance with the following:

- The clearance from the bottom of the terminal to grade shall be 12".
- The vent shall not terminate over public walkways or over an area where condensate or vapor could create a nuisance or hazard.
- The vent terminal shall be installed at least 1 foot from any opening through which flue gases could enter a building.
- The vent terminal shall have a minimum horizontal clearance of 4 feet from electric meters, gas meters, regulators and relief equipment.
- Locate the vent terminal 3 feet horizontally from the vent of any side wall vented fuel gas appliance or electric clothes dryer, except in the case where two or more of these furnaces are multi-vented. (See "Multiple Venting")
- Refer to **Figures 17A and 17B** for terminal clearances.

NOTICE

IMPORTANT: Clean and de-burr all pipe cuts. The shavings must not be allowed to block the exhaust, combustion air inlet or condensate drain lines.

NOTICE

IMPORTANT: If the pipe and fittings are to be other than PVC, use the proper cleaner, primer and cement for the dissimilar materials.

WARNING



There must not be any openings between the blower division panel and the combustion compartment. The blower compartment is under greater suction than the combustion compartment and can pull combustion air from the burners and cause incomplete combustion and erratic furnace operation.



WARNING

The vent must be clamped to the furnace panel using the gasket and clamp provided. The intake must use the threaded PVC connector with the gasket and lock nut.

Routing Options - The furnace can be installed in any of four positions. **Figures 18-25** on the following pages show the four positions. The installer must consider the following services: gas pipe, electrical power, drain trap, intake and exhaust vents. Also consider the air conditioning connections and drain, access to filter(s) and access to furnace and a/c for repair. Drains and traps of furnaces installed in spaces subjected to freezing temperature must also be protected against freezing.

The vent must be clamped to the exterior panel(s) with the clamp provided. Place the gasket between the clamp and the side panel. Tighten clamp and fasten in place using the three screws provided. The clamp should secure the vent pipe to prevent internal damage if the vent pipe is tampered with.

The combustion air inlet fitting is a 2" PVC Socket to Pipe Thread adapter. Choose the intake location and open the appropriate knock out. Install the adapter to the exterior panel using the gasket (on the outside of the panel and the locknut on the inside of the panel).

Figure 15 -Vent Clamp and Gasket

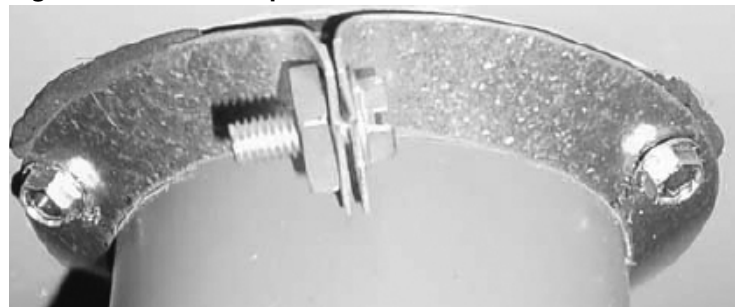

NOTICE

IMPORTANT: Keep pressure switch hose above heat exchanger drain.

Figure 16 , Table 7 - Pressure Switch Positioning

ORIENTATION		ROTATE INDUCER	RECOMMEND MOUNTING
FURNACE	FLUE		
Down	Left	Y	B or G
Down	Right	N	G
Up	Left	N	A or E
Up	Right	Y	G
Up	Vertical	N	A or E
Horz. Left	Vertical	Y	E
Horz. Right	Vertical	N	A or E
Horz. Right	Right	N	A or E

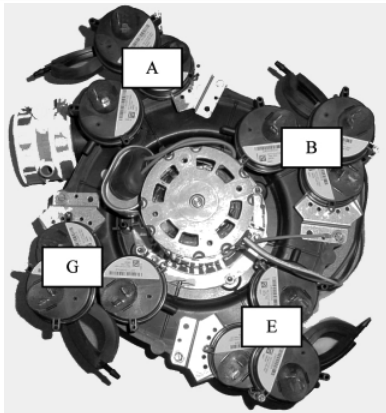

EXAMPLE: In a Horizontal Right/Vertical application (not shown), when the furnace is horizontal, room air is exiting from the right side of furnace, and the flue is vertical (existing from the left side panel in an upflow position), the pressure switch should be mounted at location A or E.

Venting Installation Instructions

1. Remove 4 inducer screws
2. Disconnect inducer wire connection.
3. Remove pressure switch and front manifold cover hose.
4. Remove pressure switches if applicable.
5. Remove inducer.
6. Reverse the bands on the rubber drain coupling so the screws are accessible if necessary. (Do not reverse the drain coupling.) Confirm that directional arrow on drain coupling point away from inducer.
7. Remove the appropriate knock out.
8. Reinstall the inducer in the correct orientation with 4 screws removed in step 1.
9. Reinstall the pressure switches so that they are above the heat exchanger drain. See pressure switches recommended mounting table.

10. Complete the venting as installation requires. If exiting the top panel, use two street elbows to route the vent. One elbow secured to the inducer, will angle toward the front of cabinet with the second nested inside directed towards the top panel. The 120,000 BTUH input unit will require an extension between the inducer and the first elbow. If exiting the side panels the pipe can be routed straight outside the cabinet. The pipe exiting the cabinet in any installation should be long enough to install the vent clamp on the outside of the cabinet.
11. Rotate the drain coupling so the drain holes are angled downward and tighten coupling bands.
12. Tighten the vent clamp and secure in place using three screws provided.

Always secure or support the vent and intake to the floor joists or rafters to avoid sagging and possible fatigue of venting materials. This ensures proper drainage and prevents spilling the products of combustion into the building.

The blower compartment should be completely isolated from the burner compartment. In tight rooms with other combustion devices, the blower compartment must be completely isolated from the room. The combustion compartment must also be completely isolated from the room (unless indirect vent). Sometimes the knockout tool will punch too deep and open holes. Use caulking on the inside of the cabinet to seal any holes. Insure that the combustion door gasket is in good condition.

Figure 17A & 17B- Direct Vent & Non-Direct Termination Clearances

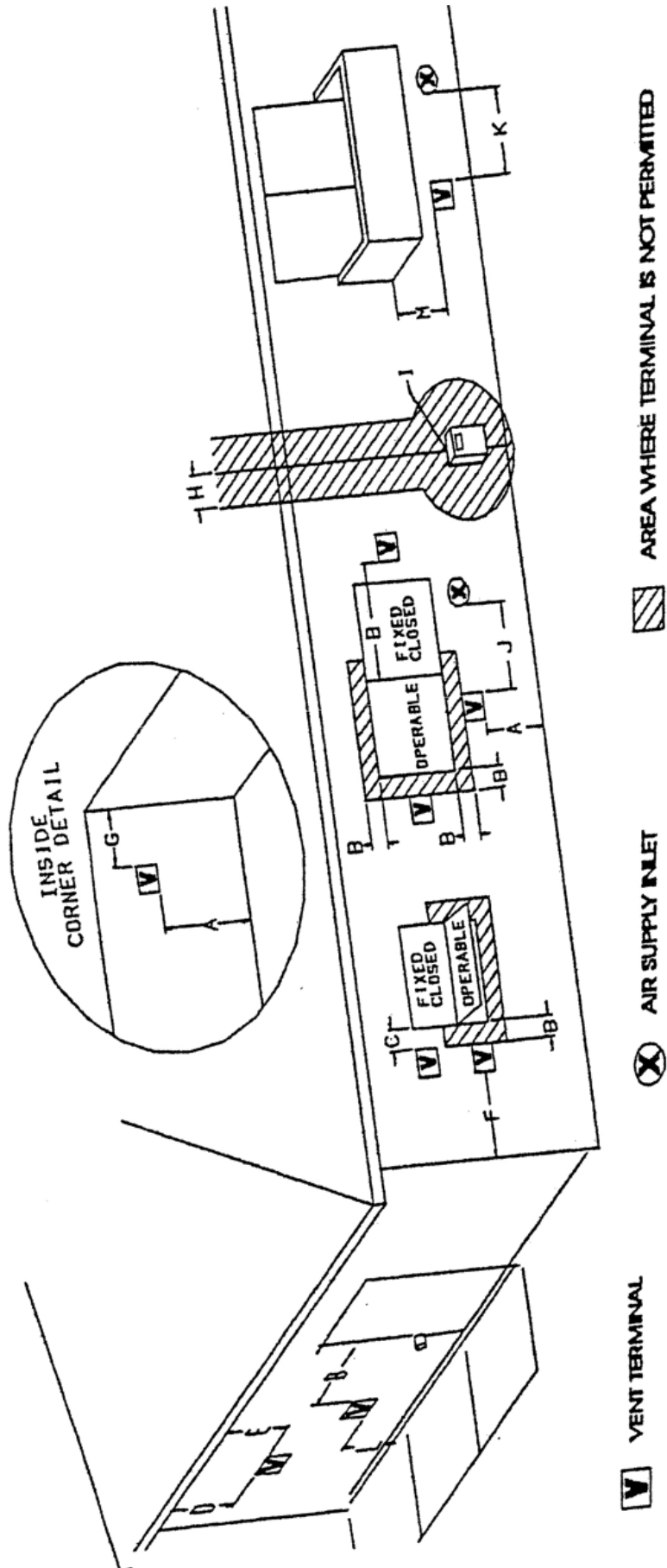

Figure 17A - Direct Vent Termination Clearances

DIRECT VENT TERMINATION CLEARANCES		
Clearance	Canadian Installations - 1	US Installations - 2
A = Clearance above grade, veranda, porch, deck, or balcony	12 inches (30cm)	12 inches (30cm)
B = Clearance to window or door that may be opened	6 inches (15cm) for appliances ≤ 10,000 Btuh (3kW), 12 inches (30 cm) for appliances > 10,000 Btuh (3kW) and ≤ 100,000 Btuh (30kW), 36 inches (91cm) for appliances > 100,000 Btuh (30kW)	6 inches (15cm) for appliances ≤ 10,000 Btuh (3kW), 9 inches (23 cm) for appliances > 10,000 Btuh (3kW) and ≤ 50,000 Btuh (15kW), 12 inches (30 cm) for appliances > 50,000 Btuh (15kW)
C = Clearance to permanently closed window	*	*
D = Vertical clearance to ventilated soffit located above the termination within a horizontal distance of 2 feet (61 cm) from the center line of the termination	*	*
E = Clearance to unventilated soffit	*	*
F = Clearance to outside corner	*	*
G = Clearance to inside corner	*	*
H = Clearance to each side of center line extended above meter/regulator assembly	3 feet (91 cm) within a height 15 feet (4.5 m) above the meter/regulator.	*
I = Clearance to service regulator vent outlet	3 feet (91 cm)	*
J = Clearance to non-mechanical air supply inlet to building or the combustion air inlet to any other appliance	6 inches (15 cm) for appliances ≤ 10,000 Btuh (3kW), 12 inches (30 cm) for appliances > 10,000 Btuh (3kW) and ≤ 100,000 Btuh (30 kW), 36 inches (91 cm) for appliances > 100,000 Btuh (30 kW)	6 inches (15 cm) for appliances ≤ 10,000 Btuh (3kW), 9 inches (23 cm) for appliances > 10,000 Btuh (3kW) and ≤ 50,000 Btuh (15 kW), 12 inches (30 cm) for appliances > 50,000 Btuh (15 kW)
K = Clearance to mechanical air supply inlet	6 feet (1.83 m)	3 feet (91 cm) above if within 10 feet (3m) horizontally
L = Clearance above paved sidewalk or paved driveway located on public property	7 feet (2.13m) +	*
M = Clearance under veranda, porch, deck or balcony	12 inches (30 cm) ++	*
<p>1 In accordance with the current CSA B149.1.1, Natural Gas and Propane Installation Code</p> <p>2 In accordance with the current ANSI Z223.1/NFPA 54, National Fuel Gas Code</p> <p>+ A vent shall not terminate directly above a sidewalk or paved driveway that is located between two single family dwellings and serves both dwellings.</p> <p>++ Permitted only if veranda, porch, deck or balcony is fully open on a minimum of two sides beneath the floor</p> <p>* For clearances not specified in ANSI Z223.1/NFPA 54 or CSA B149.1, the following statement shall be included: "Clearance in accordance with local installation codes and the requirements of the gas supplier and the manufacturer's installation instructions."</p>		

Figure 17B - Non-Direct Vent Termination Clearances

NON - DIRECT VENT TERMINATION CLEARANCES		
Clearance	Canadian Installations - 1	US Installations -2
A = Clearance above grade, veranda, porch, deck, or balcony	12 inches (30cm)	12 inches (30cm)
B = Clearance to window or door that may be opened	6 inches (15cm) for appliances ≤ 10,000 Btuh (3kW), 12 inches (30 cm) for appliances > 10,000 Btuh (3kW) and ≤ 100,000 Btuh (30kW), 36 inches (91cm) for appliances > 100,000 Btuh (30kW)	4 feet (1.2 m) below or to side of opening, 1 foot (30 cm) above opening
C = Clearance to permanently closed window	*	*
D = Vertical clearance to ventilated soffit located above the termination within a horizontal distance of 2 feet (61 cm) from the center line of the termination	*	*
E = Clearance to unventilated soffit	*	*
F = Clearance to outside corner	*	*
G = Clearance to inside corner	*	*
H = Clearance to each side of center line extended above meter/regulator assembly	3 feet (91 cm) within a height 15 feet (4.5 m) above the meter/regulator.	*
I = Clearance to service regulator vent outlet	3 feet (91 cm)	*
J = Clearance to non-mechanical air supply inlet to building or the combustion air inlet to any other appliance	6 inches (15 cm) for appliances ≤ 10,000 Btuh (3kW), 12 inches (30 cm) for appliances > 10,000 Btuh (3kW) and ≤ 100,000 Btuh (30 kW), 36 inches (91 cm) for appliances > 100,000 Btuh (30 kW)	4 feet (1.2 m) below or to side of opening, 1 foot (30 cm) above opening
K = Clearance to mechanical air supply inlet	6 feet (1.83 m)	3 feet (91 cm) above if within 10 feet (3m) horizontally
L = Clearance above paved sidewalk or paved driveway located on public property	7 feet (2.13m) +	7 feet (2.13m)
M = Clearance under veranda, porch, deck or balcony	12 inches (30 cm) ++	*
<p>1 In accordance with the current CSA B149.1.1, Natural Gas and Propane Installation Code</p> <p>2 In accordance with the current ANSI Z223.1/NFPA 54, National Fuel Gas Code</p> <p>+ A vent shall not terminate directly above a sidewalk or paved driveway that is located between two single family dwellings and serves both dwellings.</p> <p>++ Permitted only if veranda, porch, deck or balcony is fully open on a minimum of two sides beneath the floor</p> <p>* For clearances not specified in ANSI Z223.1/NFPA 54 or CSA B149.1, the following statement shall be included: "Clearance in accordance with local installation codes and the requirements of the gas supplier and the manufacturer's installation instructions."</p>		

Instructions for Upflow with Top Venting

1.	Connect two (2) 2" Street elbows (in parts bag) to the coupler on the exhauster (Add 2" nipple for 120K BTU units). Ensure exhauster coupler drain outlet is facing downward 15°.
2.	Remove 2.5" knockout and connect 2" vent pipe (field supplied). If using 1.5" or 3" vent, make transition as close as possible to the unit and on a vertical section.
3.	Install gasket on panel then vent bracket, use three (3) self tapping screws (all parts from parts bag).
4.	Remove 2.5" knockout and connect 2" air intake coupler with gasket on the outside of unit using the 2" nut (all parts from parts bag). If using 1.5" or 3" intake, make transition as close as possible to the unit and on a vertical section.
5.	Connect 2" intake pipe (field supplied)
6.	Remove two (2) 7/8" knockouts and install the condensate trap with gasket, hold in place with two (2) screws (all parts supplied in parts bag). **Condensate trap can be placed on either side of unit**
7.	**IMPORTANT** Connect a 1/2" tee fitting (field supplied) to the outlet of the condensate trap.
8.	Connect 1/2" drain tube (field supplied) and route to floor drain or condensate pump.
9.	Connect one end of the 5/8" tubing (in parts bag) to the drain on the front manifold cover, route to the larger outlet on the condensate trap, cut excess tube and hold in place with supplied hose clamps. Tubing should slope towards drain trap with no sags.
10.	Connect one end of the 1/2" tubing (in parts bag) to the lower drain outlet on the exhauster coupler, route to the smaller inlet on the condensate trap, cut excess tube and hold in place with supplied hose clamps. Tubing should slope towards drain trap with no sags.

Figure 18 - Upflow with Top Venting

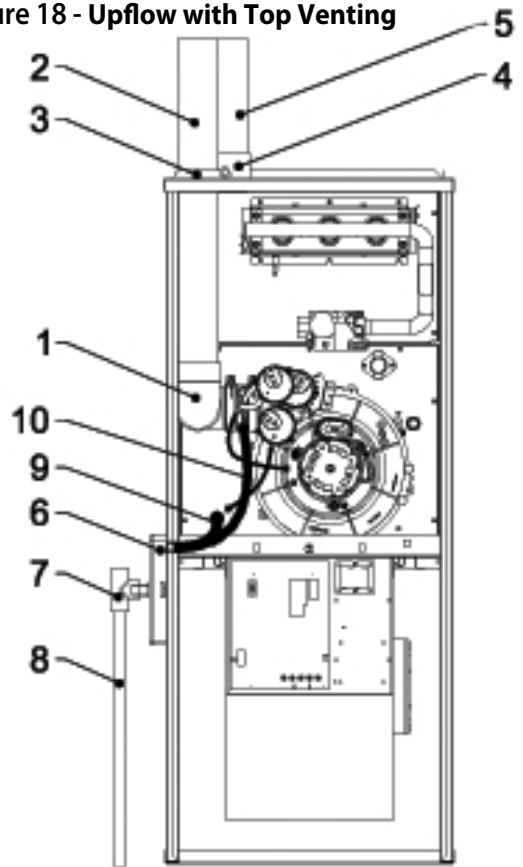

Instructions for Upflow with Left Side Venting

1.	Remove 2.5" knockout and connect 2" nipple approximately 7" long (field supplied) to the coupler on the exhauster. Ensure exhauster coupler drain outlet is facing downward 15°.
2.	Connect 2" elbow and 2" vent pipe (field supplied)
3.	Install gasket on panel then vent bracket, use three (3) self tapping screws (all parts from parts bag.) If using 1.5" or 3" vent, make transition as close as possible to the unit and on a vertical section.
4.	Remove 2.5" knockout and connect 2" air intake coupler with gasket on the outside of unit, use the 2" nut to fasten this (all parts from parts bag).
5.	Connect 2" street elbow (from parts bag) and intake pipe (field supplied). If using 1.5" or 3" intake, make transition as close as possible to the unit and on a vertical section.
6.	Remove two (2) 7/8" knockouts and install the condensate trap with gasket, hold in place with two (2) screws (all parts supplied in parts bag). **Condensate trap can be placed on either side of unit**
7.	**IMPORTANT** Connect a 1/2" tee fitting (field supplied) to the outlet of the condensate trap.
8.	Connect 1/2" drain tube (field supplied) and route to floor drain or condensate pump.
9.	Connect one end of the 5/8" tubing (in parts bag) to the drain on the front manifold cover, route to the larger outlet on the condensate trap, cut excess tube and hold in place with supplied hose clamps. Tubing should slope towards drain trap with no sags.
10.	Connect one end of the 1/2" tubing (in parts bag) to the lower drain outlet on the exhauster coupler, route to the smaller inlet on the condensate trap, cut excess tube and hold in place with supplied hose clamps. Tubing should slope towards drain trap with no sags.

Figure 19 - Upflow with Left Side Venting

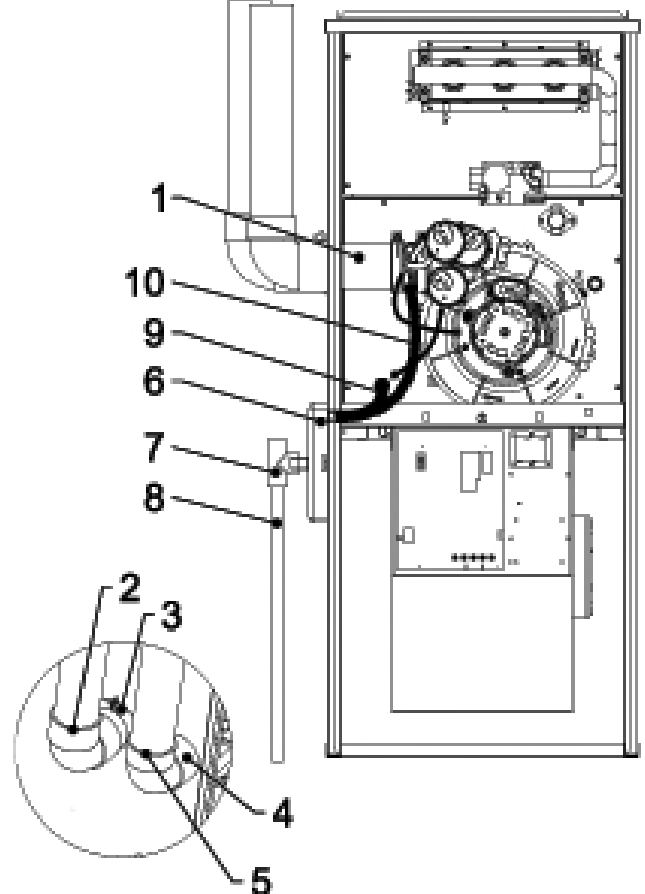

15 - VENT AND DRAINING OPTION - UPFLOW

Instructions for Upflow with Right Side Venting	
1.	Remove 2.5" knockout and connect 2" nipple approximately 2.5" long (field supplied) to the coupler on the exhauster. Ensure exhauster coupler drain outlet is facing downward 15°.
2.	Connect 2" elbow and 2" vent pipe (field supplied)
3.	Install gasket on panel then vent bracket, use three (3) self tapping screws (all parts from parts bag). If using 1.5" or 3" vent, make transition as close as possible to the unit and on a vertical section.
4.	Remove 2.5" knockout and connect 2" air intake coupler with gasket on the outside of unit, use the 2" nut to fasten this (all parts from parts bag).
5.	Connect 2" elbow and intake pipe (field supplied). If using 1.5" or 3" intake, make transition as close as possible to the unit and on a vertical section.
6.	Remove two (2) 7/8" knockouts and install the condensate trap with gasket, hold in place with two (2) screws (all parts supplied in parts bag). **Condensate trap can be placed on either side of unit**
7.	**IMPORTANT** Connect a 1/2" tee fitting (field supplied) to the outlet of the condensate trap.
8.	Connect 1/2" drain tube (field supplied) and route to floor drain or condensate pump.
9.	Connect one end of the 5/8" tubing (in parts bag) to the drain on the front manifold cover, route to the larger outlet on the condensate trap, cut excess tube and hold in place with supplied hose clamps. Tubing should slope towards drain trap with no sags.
10.	Connect one end of the 1/2" tubing (in parts bag) to the lowest drain outlet on the exhauster coupler, route to the smaller inlet on the condensate trap, cut excess tube and hold in place with supplied hose clamps. Tubing should slope towards drain trap with no sags.

Figure 20 - Upflow with Right Side Venting

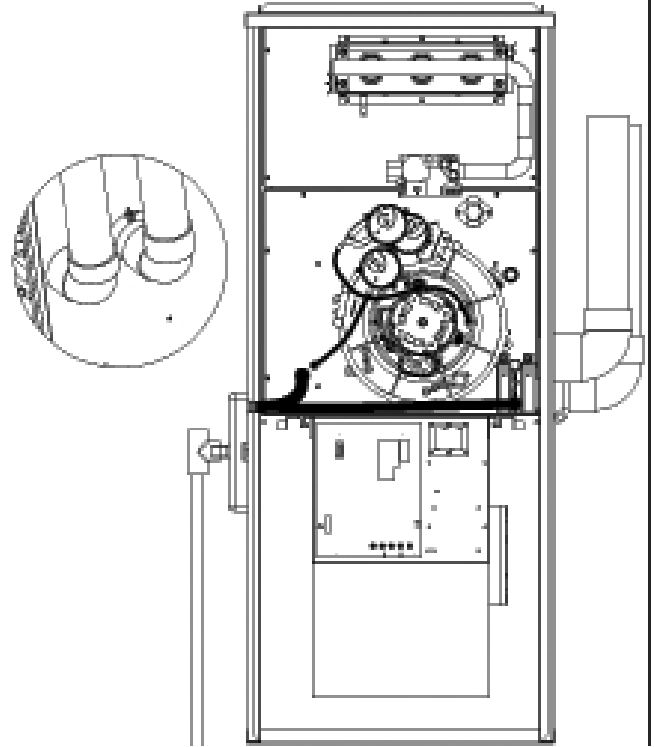

15- VENT AND DRAINING OPTION - HORIZONTAL LEFT

Figure 21 - Horizontal Left with Top Venting

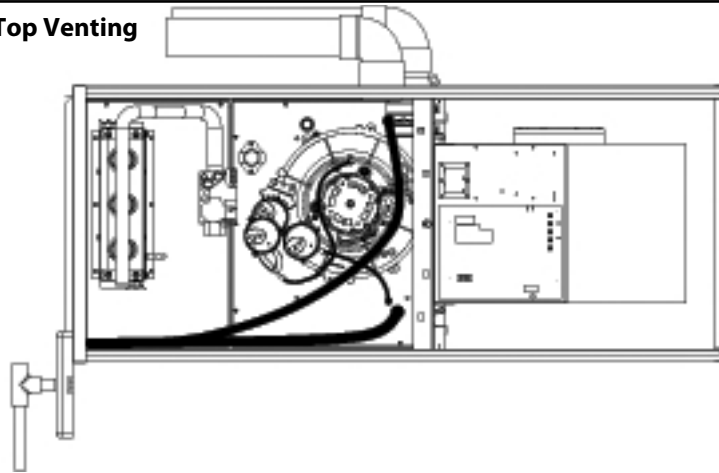

Instructions for Horizontal Left with Top Venting			
1.	Remove 2.5" knockout and connect 2" nipple approximately 2.5" long (field supplied) to the coupler on the exhauster. Ensure exhauster coupler drain outlet is facing downward 15°.	6.	Remove two (2) 7/8" knockouts and install the condensate trap bracket by removing and reusing the 2 top panel screws, install condensate trap with gasket, hold in place with 2 screws (all parts supplied in parts bag).
2.	Connect 2" elbow and 2" vent pipe (field supplied).	7.	**IMPORTANT** Connect a 1/2" tee fitting (field supplied) to the outlet of the condensate trap.
3.	Install gasket on panel then vent bracket, use three (3) self tapping screws (all parts from parts bag). If using 1.5" or 3" vent, make transition as close as possible to the unit and on a vertical section.	8.	Connect 1/2" drain tube (field supplied) and route to floor drain or condensate pump.
4.	Remove 2.5" knockout and connect 2" air intake coupler with gasket on the outside of unit, use the 2" nut to fasten this (all parts from parts bag). **Refer to page 26 for inducer orientation**	9.	Connect one end of the 5/8" tubing (in parts bag) to the drain on the front manifold cover, route to the larger outlet on the condensate trap, cut excess tube and hold in place with supplied hose clamps. Tubing should slope towards drain trap with no sags.
5.	Connect 2" street elbow (from parts bag) and intake pipe (field supplied). If using 1.5" or 3" intake, make transition as close as possible to the unit and on a vertical section.	10.	Connect one end of the 1/2" tubing (in parts bag) to the lower drain outlet on the exhauster coupler, route to the smaller inlet on the condensate trap, cut excess tube and hold in place with supplied hose clamps. Tubing should slope towards drain trap with no sags.

Figure 22 - Horizontal Right with Right Side Venting

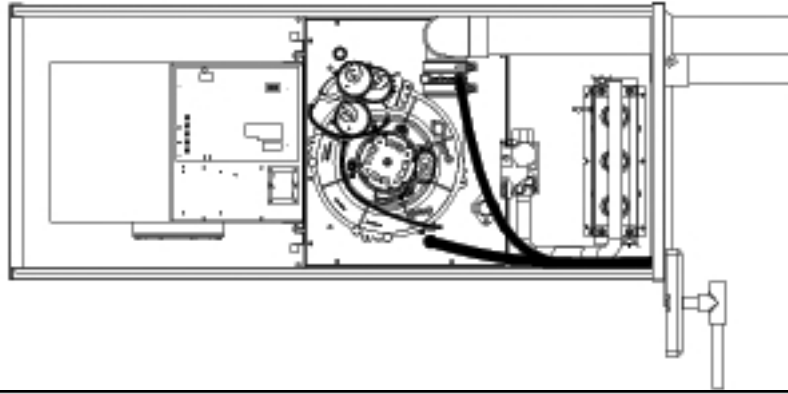

Instructions for Horizontal Right with Right Side Venting	
1. Connect two (2) 2" Street elbows (in parts bag) to the coupler on the exhauster (Add 2" nipple for 120K BTU units). Ensure exhauster coupler drain outlet is facing downward 15°.	6. Remove two (2) 7/8" knockouts and install the condensate trap bracket by removing and reusing the 2 top panel screws, install condensate trap with gasket, hold in place with 2 screws (all parts supplied in parts bag).
2. Remove 2.5" knockout and connect 2" vent pipe (field supplied). If using 1.5" or 3" vent, make transition as close as possible to the unit and on a vertical section.	7. **IMPORTANT** Connect a 1/2" tee fitting (field supplied) to the outlet of the condensate trap.
3. Install gasket on panel then vent bracket, use three (3) self tapping screws (all parts from parts bag). If using 1.5" or 3" vent, make transition as close as possible to the unit and on a vertical section.	8. Connect 1/2" drain tube (field supplied) and route to floor drain or condensate pump.
4. Remove 2.5" knockout and connect 2" air intake coupler with gasket on the outside of unit, use the 2" nut to fasten this (all parts from parts bag). **Refer to page 26 for inducer orientation**	9. Connect one end of the 5/8" tubing (in parts bag) to the drain on the front manifold cover, route to the larger outlet on the condensate trap, cut excess tube and hold in place with supplied hose clamps. Tubing should slope towards drain trap with no sags.
5. Connect 2" street elbow (from parts bag) and intake pipe (field supplied). If using 1.5" or 3" intake, make transition as close as possible to the unit and on a vertical section.	10. Connect one end of the 1/2" tubing (in parts bag) to the lower drain outlet on the exhauster coupler, route to the smaller inlet on the condensate trap, cut excess tube and hold in place with supplied hose clamps. Tubing should slope towards drain trap with no sags.

Figure 23 - Horizontal Right with Top Venting

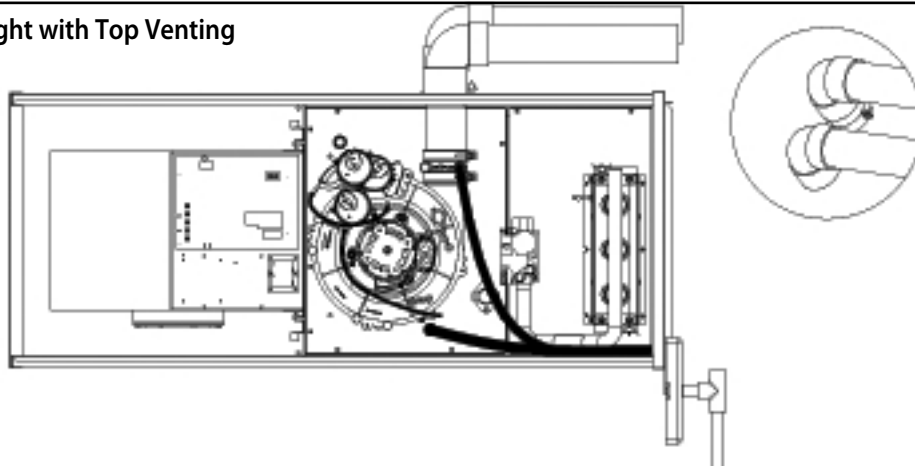

Instructions for Horizontal Right with Top Venting	
1. Remove 2.5" knockout and connect 2" nipple approximately 7" long (field supplied) to the coupler on the exhauster. Ensure exhauster coupler outlet is facing right side approximately 15°.	6. Remove two (2) 7/8" knockouts and install the condensate trap bracket by removing and reusing the 2 top panel screws, install condensate trap with gasket, hold in place with 2 screws (all parts supplied in parts bag).
2. Connect 2" elbow and 2" vent pipe (field supplied).	7. **IMPORTANT** Connect a 1/2" tee fitting (field supplied) to the outlet of the condensate trap.
3. Install gasket on panel then vent bracket, use three (3) self tapping screws (all parts from parts bag). If using 1.5" or 3" vent, make transition as close as possible to the unit and on a vertical section.	8. Connect 1/2" drain tube (field supplied) and route to floor drain or condensate pump.
4. Remove 2.5" knockout and connect 2" air intake coupler with gasket on the outside of unit, use the 2" nut to fasten this (all parts from parts bag). **Refer to page 26 for inducer orientation**	9. Connect one end of the 5/8" tubing (in parts bag) to the drain on the front manifold cover, route to the larger outlet on the condensate trap, cut excess tube and hold in place with supplied hose clamps. Tubing should slope towards drain trap with no sags.
5. Connect 2" street elbow (from parts bag) and intake pipe (field supplied). If using 1.5" or 3" intake, make transition as close as possible to the unit and on a vertical section.	10. Connect one end of the 1/2" tubing (in parts bag) to the lower drain outlet on the exhauster coupler, route to the smaller inlet on the condensate trap, cut excess tube and hold in place with supplied hose clamps. Tubing should slope towards drain trap with no sags.

15 - VENT AND DRAINING OPTION - DOWNFLOW

Instructions for Downflow with Left Side Venting	
1.	Remove 2.5" knockout and connect 2" nipple approximately 2.5" long (field supplied) to the coupler on the exhauster. Ensure exhauster coupler drain outlet is facing downward 15°.
2.	Connect 2" elbow and 2" vent pipe (field supplied)
3.	Install gasket on panel then vent bracket, use three (3) self tapping screws (all parts from parts bag). If using 1.5" or 3" vent, make transition as close as possible to the unit and on a vertical section.
4.	Remove 2.5" knockout and connect 2" air intake coupler with gasket on the outside of unit, use the 2" nut to fasten this (all parts from parts bag).
5.	Connect 2" street elbow (from parts bag) and intake pipe (field supplied). If using 1.5" or 3" intake, make transition as close as possible to the unit and on a vertical section.
6.	Remove two (2) 7/8" knockouts and install the condensate trap with gasket, hold in place with two (2) screws (all parts supplied in parts bag). **Condensate trap can be placed on either side of unit**
7.	**IMPORTANT** Connect a 1/2" tee fitting (field supplied) to the outlet of the condensate trap.
8.	Connect 1/2" drain tube (field supplied) and route to floor drain or condensate pump.
9.	Connect one end of the 5/8" tubing (in parts bag) to the drain on the front manifold cover, route to the larger outlet on the condensate trap, cut excess tube and hold in place with supplied hose clamps. Tubing should slope towards drain trap with no sags.
10.	Connect one end of the 1/2" tubing (in parts bag) to the lower drain outlet on the exhauster coupler, route to the smaller inlet on the condensate trap, cut excess tube and hold in place with supplied hose clamps. Tubing should slope towards drain trap with no sags.

Figure 24 - Downflow with Left Side Venting

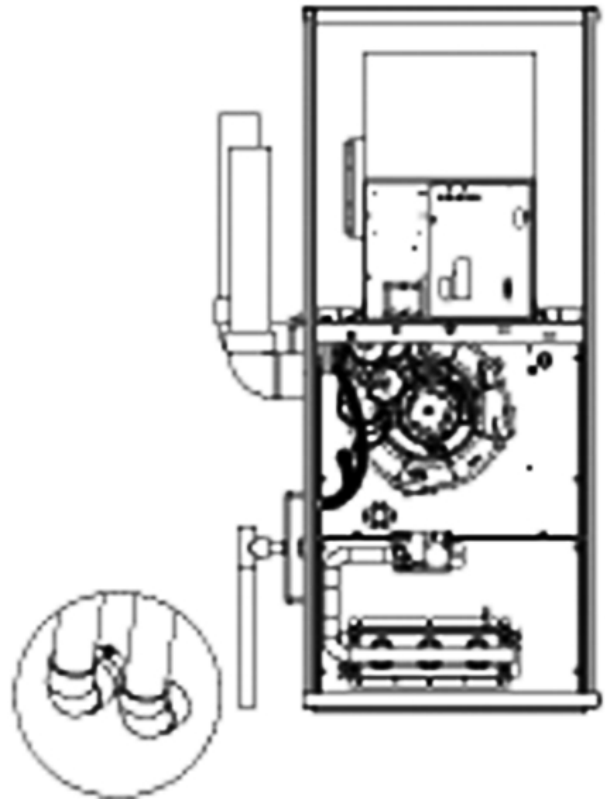

Instructions for Downflow with Right Side Venting	
1.	Remove 2.5" knockout and connect 2" nipple approximately 7" long (field supplied) to the coupler on the exhauster. Ensure exhauster coupler drain outlet is facing downward 15°.
2.	Connect 2" elbow and 2" vent pipe (field supplied).
3.	Install gasket on panel then vent bracket, use three (3) self tapping screws (all parts from parts bag). If using 1.5" or 3" vent, make transition as close as possible to the unit and on a vertical section.
4.	Remove 2.5" knockout and connect 2" air intake coupler with gasket on the outside of unit, use the 2" nut to fasten this (all parts from parts bag).
5.	Connect 2" street elbow (from parts bag) and intake pipe (field supplied). If using 1.5" or 3" intake, make transition as close as possible to the unit and on a vertical section.
6.	Remove two (2) 7/8" knockouts and install the condensate trap with gasket, hold in place with two (2) screws (all parts supplied in parts bag). **Condensate trap can be placed on either side of unit**
7.	**IMPORTANT** Connect a 1/2" tee fitting (field supplied) to the outlet of the condensate trap.
8.	Connect 1/2" drain tube (field supplied) and route to floor drain or condensate pump.
9.	Connect one end of the 5/8" tubing (in parts bag) to the drain on the front manifold cover, route to the larger outlet on the condensate trap, cut excess tube and hold in place with supplied hose clamps. Tubing should slope towards drain trap with no sags.
10.	Connect one end of the 1/2" tubing (in parts bag) to the lower drain outlet on the exhauster coupler, route to the smaller inlet on the condensate trap, cut excess tube and hold in place with supplied hose clamps. Tubing should slope towards drain trap with no sags.

Figure 25 - Downflow with Right Side Venting

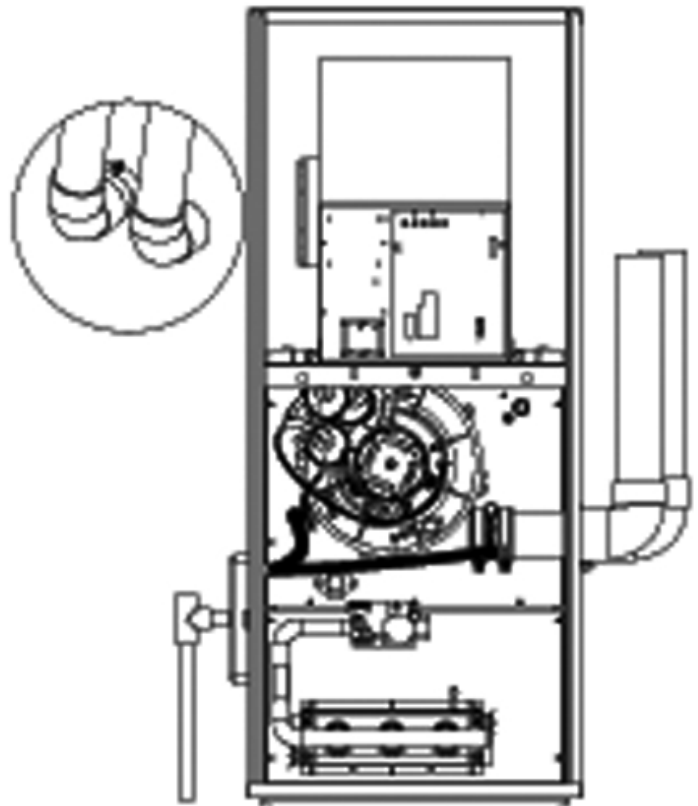

The furnace may condense as much as a 4½ pounds of water per hour (approximately 2 imperial quarts, 2½ U.S. quarts or 2¼ liters). It is necessary to make provisions for draining the condensate away. The furnace is supplied with a drain trap assembly. See **Figures 18-25** for possible locations of the drain trap.

The drain coupling on the inducer will work better if the drain holes are pointed down about 15 degrees. The drain hose supplied with the furnace is long enough to reach either side panel; however, it must be cut near the blower division panel. This is to prevent kinking in the drain lines.

CAUTION



The two inlets to the drain trap are for vent pipe and condensate collection. The vent pipe inlet is smaller than the condensate collection inlet. Ensure that the drain hoses are properly connected.

Drain Hose Installation

1. Select a drain trap location suitable for the orientation of the furnace and remove the corresponding knockouts. See **Figures 18-25**.
2. Affix the drain trap assembly to the exterior of the side panel when the furnace is upflow or downflow using two screws provided. For horizontal positions the installer will need to use the mounting bracket supplied and secure the bracket to the top panel. Remove two top panel screws and fasten bracket to top panel with removed screws. Secure trap assembly using screws provided to the mounting bracket.
3. Slide the short end of the 5/8" formed tube over the appropriate condensate outlet on the front manifold cover, and fasten by tightening the tube clamp approximately 1/8" from the end of the tube.
4. Cut the formed drain tube to the required length if necessary, and slide tube over the condensate inlet on the drain trap (larger diameter inlet hole). Fasten by tightening the tube clamp approximately 1/8" from the end of the tube.
5. Rotate exhauster coupling 15 degrees downwards, and remove the yellow cap over the lowest vent drain outlet. Slide the short end of the 1/2" drain tube on the exhauster coupling drain. Fasten by tightening the tube clamp approximately 1/8" from the end of the tube.

6. Cut the formed vent drain tube to the required length if necessary, and slide over inlet on the drain trap (smaller diameter inlet hole). Fasten by tightening the tube clamp approximately 1/8" from the end of the tube.
7. All drain tubes must slope towards the drain trap.

CAUTION



Ensure that drain hoses do not create traps prior to the condensate trap assembly. A secondary trap will cause intermittent operation due to the pressure switches opening.

Drain Piping

Condensate from the outlet of the drain trap assembly must be conveyed to a floor drain, sump pit, or, if these are unavailable, to a condensate pump. If using a condensate pump, be sure that it is approved for furnace condensate.

CAUTION



Do not drain the condensate outdoors. Do not run the condensate line through areas where freezing might occur. Freezing of condensate can result in erratic furnace operation and in property damage.

Figure 26 - Condensate Trap/Condensate Drainage With Vent



Figure 27 - Condensate Bypass

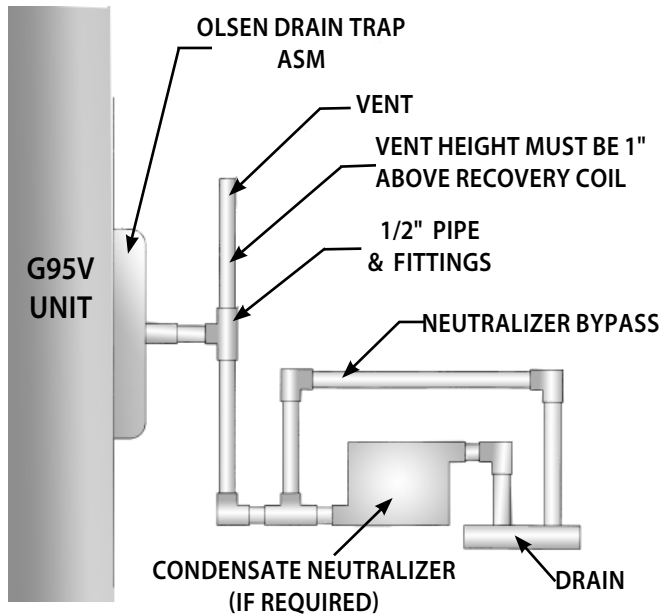

The condensate drainage configuration requires a vent. It takes less than a one inch rise anywhere along the horizontal route of the drain tube to create a vapor lock, which will prevent condensate from draining away freely, and result in erratic furnace operation.

A typical configuration would be to cement the side branch of a 1/2" PVC tee to the drain trap assembly outlet, with the end branches oriented vertically. (Figure 27)

A 1" piece of 1/2" PVC pipe cemented to the upper end branch will serve as a vent, which will prevent the creation of a vapor lock, and serve as an overflow in the event that the drain line becomes blocked. A similarly sized piece of pipe cemented to the lower end branch will permit connection to the condensate outlet with 5/8" ID / 7/8" OD flexible tubing, or the condensate may be piped entirely in PVC to the floor drain/sump/condensate pump.

NOTICE

IMPORTANT: If an air conditioning evaporator coil drain is to share the furnace drain line, it should be connected with a tee fitting downstream from the trap. Do not connect the evaporator coil condensate drain upstream of the furnace drain trap assembly.

Condensate Neutralizers

Some local codes may require the use of a condensate neutralizer. If the furnace condensate is to be routed to a septic system, it may be advisable to use a condensate neutralizer.

Condensate neutralizers such as the Ward Industries 90+ Neutralizer are available through heating supply wholesalers.

When condensate neutralizers are used, it is advisable to install it with an overflow bypass tube. (Figure 27)

NOTICE

IMPORTANT: The condensate drain trap assembly should be full of water before starting the furnace. To fill the condensate drain trap assembly, temporarily remove the vent drain hose from the induced blower assembly elbow/drain fitting, and pour approximately one cup of water down the hose. Water will begin running out the condensate drain trap outlet when it is full. Refasten the vent drain hose to the induced blower assembly elbow/drain fitting.

17 - GAS SUPPLY AND PIPING

Gas Supply

WARNING

THIS FURNACE IS FACTORY EQUIPPED TO BURN NATURAL GAS ONLY.



CONVERSION TO LP GAS REQUIRES SPECIAL NATURAL GAS TO LP CONVERSION KIT.

FAILURE TO USE THE PROPER CONVERSION KIT CAN CAUSE FIRE, EXPLOSION, CARBON MONOXIDE POISONING, PROPERTY DAMAGE, PERSONAL INJURY OR LOSS OF LIFE.

NOTICE

IMPORTANT: Conversion of this furnace requires specialized equipment. Conversion must be completed by a trained and qualified installer, service agency or gas supplier.

NOTICE

IMPORTANT: Connect this furnace only to gas supplied by a commercial utility or supplier. Private gas wells do not generally provide gas with consistent, uniform and predictable heating values and densities. Many non-commercial wells contain impurities such as sulphur, which may damage the furnace. This furnace cannot operate properly or safely using fuels outside normal commercial standards.

Gas Piping

In Canada, the gas piping should be installed in accordance with CAN/CGA-B149.1 and 2, and in accordance with any local codes.

In the United States, the gas piping should be installed in accordance with NFPA 54 / ANSI Z223.1 and any local codes.

If local codes allow the use of a flexible gas appliance connector, always use a new listed connector. Do not use a connector, which has previously serviced another gas appliance.

NOTICE

IMPORTANT: To maintain a good seal in the burner area, the gas piping through the side panel into the furnace must be ½" A53 black iron pipe. The pipe passes through a special rubber grommet that is custom manufactured to seal tightly around the gas pipe.

Figure 28 - Furnace Gas Pipe Connections (Note Rubber Grommet)



The gas piping may enter the furnace from either side. Once the routing of the gas pipe is determined, select and remove the applicable knockout and install the grommet within the hole.

Install a BMI ground joint union between the gas valve and the side panel to allow easy removal of the burner for service purposes.

NOTICE

IMPORTANT: Always use a backup wrench to prevent twisting of the control assembly and gas valve. Any strains on the gas valve can affect positioning of the orifices relative to the burners. This could result in faulty burner operation.

Install a manual gas shut-off valve and dirt pocket as close to the furnace as possible. Some local codes call for the manual gas shut-off valve to be located between 4 to 5 feet above floor level to prevent tampering by small children. Ensure that the valve is readily accessible.

NOTICE

IMPORTANT: Ensure that the manual shut-off valve and gas valve are not subjected to high pressures.



WARNING

Indicates an imminently hazardous situation which, if not avoided, may result in death, serious injury or substantial property damage.

Gas Inlet Pressure

The natural gas inlet supply pressure should be 5" to 7" w.c. (7" w.c. recommended). The LP gas inlet supply pressure should be 11" to 14" w.c. (12" w.c. recommended). These pressures must be maintained while all other gas fired appliances are operating at maximum conditions.

NOTICE

IMPORTANT: Do not exceed 14" w.c. inlet pressure with either fuel.

The gas valve has two adjustable internal regulators for controlling burner manifold pressure. Burner manifold high fire and low fire pressures are listed on the furnace rating plate.

Leak Testing

All new gas piping installations should be pressure tested as specified by CAN/CGA-B149.1 & 2, or NFPA 54 ANSI Z223.1 or ANSI/NFPA 58, "Standard for the Storage and Handling of Liquefied Petroleum Gases."

Gas piping that has not been pressure tested, from the manual shut-off valve to the furnace gas valve for example, should be leak tested using an electronic combustible gas detector, a commercially prepared leak detector, or other locally approved method. A leak detector solution can be prepared by mixing a small quantity of dish detergent with water and daubing it onto the gas piping, especially the joints.

Purging Gas Lines

WARNING

NEVER PURGE A GAS LINE INTO THE COMBUSTION CHAMBER.



NEVER USE A MATCH, TAPER, CIGARETTE LIGHTER, FLAME OR ANY OTHER IGNITION SOURCE TO CHECK FOR LEAKS IN A GAS LINE.

FAILURE TO ADHERE TO THIS WARNING CAN CAUSE A FIRE OR EXPLOSION RESULTING IN PROPERTY DAMAGE, PERSONAL INJURY, OR LOSS OF LIFE.

18 - CONVERSIONS

HIGH ALTITUDE: In Canada, the furnace may be converted for high altitude (2000-4500 feet) by changing the burner orifices. The Conversion Kit part number 550001641 contains both natural gas and LP gas orifices. (**Table 9**)

In the United States, the modifications for high altitude are based on a 2% reduction of input capacity for every 1000 feet above 2000 feet above sea level. **Table 8** illustrates the impact of altitude for selected elevations. Consult with local fuel suppliers or authorities to determine local regulations or customs.

NATURAL TO LP GAS: This series furnace is manufactured as a natural gas (sea level) appliance that may be converted to LP gas through use of the Conversion Kit part number 550001648. This kit contains the orifices needed for all models, the regulator springs for the gas valve, and a label to affix adjacent to the appliance rating plate to alert subsequent service technicians of the conversion.

LP TO NATURAL GAS: Although the furnace is manufactured initially as a natural gas appliance, if, after an LP gas conversion it becomes necessary to convert back to natural gas and the original parts are unavailable, The Conversion Kit part number 550001816 may be obtained.

Figure 29 - Inshot Burner Assembly



TABLE 8 - HIGH ALTITUDE SPECIFICATIONS (U.S.A.)

MODEL	ALTITUDE (FT)	ORIFICE SIZE (DMS)	
		NATURAL	LP GAS
All	0-2000	45	55
	2000-3000	48	56
	3000-4000	49	57
	4000-5000	50	58
	5000-6000	51	60
	6000-7000	52	61
	7000-8000	53	62
	8000-9000	54	63
	9000-10000	55	65

† Gas input ratings are certified for elevations to 2000 ft. For elevations above 2000 ft, reduce ratings 2% for each 1000 ft above sea level. In Canada, derate the unit 5% for elevations from 2000 to 4000 ft above sea level.

TABLE 9- HIGH ALTITUDE SPECIFICATIONS (CANADA)

MODEL	ALTITUDE (FT)	INPUT BTU/HR	OUTPUT BTU/HR	ORIFICE SIZE (DMS)		QTY.
				NATURAL	LP GAS	
60	0 - 2000	60000	57000	45	55	3
	2000 - 4500	54000	51300	46	56	
80	0 - 2000	80000	76000	45	55	4
	2000 - 4500	72000	68400	46	56	
100	0 - 2000	100000	95000	45	55	5
	2000 - 4500	90000	85500	46	56	
120	0 - 2000	120000	114000	45	55	6
	2000 - 4500	108000	102600	46	56	

† Gas input ratings are certified for elevations to 2000 ft. For elevations above 2000 ft, reduce ratings 2% for each 1000 ft above sea level. In Canada, derate the unit 5% for elevations from 2000 to 4000 ft

Conversion Steps

To convert from sea level to high altitude, from natural gas to LP gas, or from LP gas to natural gas, follow these steps:

1. Turn off gas supply to the furnace.
2. Shut off electrical power to the furnace.
3. Remove the front door to expose the gas train and burner assembly.
4. Unfasten the ground joint union between the gas valve and gas supply piping if applicable.
5. Unplug the wires connected to the gas valve.
6. Unfasten the burner manifold pipe from the burner assembly. It is held in place by 2 screws on either end of the manifold pipe.
7. Remove the existing orifices with a 7/16" socket, box or open end wrench. Install the replacement orifices. The orifice spuds are brass, and do not normally require pipe dope. A light grease may be used to lubricate the threads. The orifice spuds have tapered threads. **DO NOT OVER-TIGHTEN!!**

Figure 30 - White-Rodgers 36G54 Springs and Regulator Screws

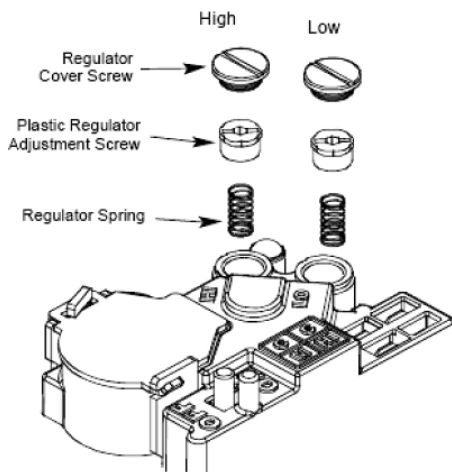

8. Re-install the burner manifold pipe assembly following steps 4, 5, and 6 in reverse order.
9. Remove both regulator cover screws. See **Figure 30**.
10. Remove both regulator adjustment screws (beneath the cover screws).
11. Remove both Natural Gas regulator springs (color-coded silver/plain) from regulator sleeves.
12. Insert the L.P. regulator springs (provided in the conversion kit and color-coded white) into the regulator sleeves.
13. Replace the High regulator adjustment screw and adjust approximately 12 turns in, from fully out.
14. Replace the Low regulator adjustment screw and adjust approximately 8 turns in, from fully out.
15. Apply a liberal amount of pipe joint compound or pipe thread tape to the threads and reassemble the piping previously removed. Note: the pipe joint compound must be resistant to L.P. gas.

Figure 31 - White Rodgers 36G54 Gas Valve

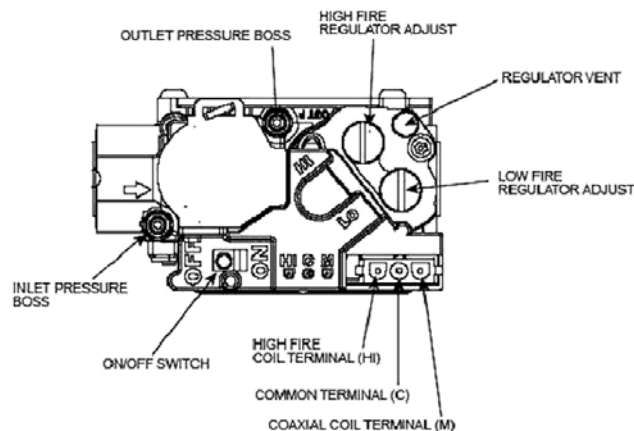

Checking The INLET Gas Pressure

White-Rodgers 36G54 Two Stage Gas Valve.

1. Turn off the gas and electrical supply.
2. Back inlet pressure test screw (inlet pressure boss, see **Figure 31**) out one turn (counterclockwise, not more than one turn) with a 3/32" Allen wrench.
3. Attach a hose and calibrated U-tube manometer to the inlet pressure boss. Hose should overlap boss 3/8". The manometer must have a scale range of at least 0" to 15" of water column.
4. Turn ON the gas and electrical supply and operate the furnace and all other gas consuming appliances on the same gas supply line. Using a soap and water solution, check for leaks around the gas valve/manifold connection and the burner orifices. Repair any leaks before continuing.

5. Measure furnace gas inlet pressure with burners firing. Inlet pressure must be within the range specified on the furnace rating plate. 5-7" w.c (Natural Gas) or 11-14" w.c. (LP). If the inlet pressure differs from the rating plate, make the necessary adjustments to pressure regulator, gas piping size, etc. and/or consult with local gas utility.
6. Turn off gas and electrical supply to furnace, remove the manometer hose from the inlet pressure tap boss, and tighten the inlet pressure tap screw using the 3/32" Allen wrench. (clockwise, 7 in-lb minimum).
7. If working on a natural gas system, contact the gas utility. They may insist on any service regulator adjustments being made by their own staff.

If problems were encountered with obtaining enough pressure on the manifold, first examine the gas piping system to ensure that it is correctly sized. Pipe sizing is specified in CAN/CGA-B-149.1 & 2, and in NFPA 54 / ANSI Z223.1. Be sure to check for restrictions, partially closed valves, etc.

Figure 32 - Valve Pressure Kit

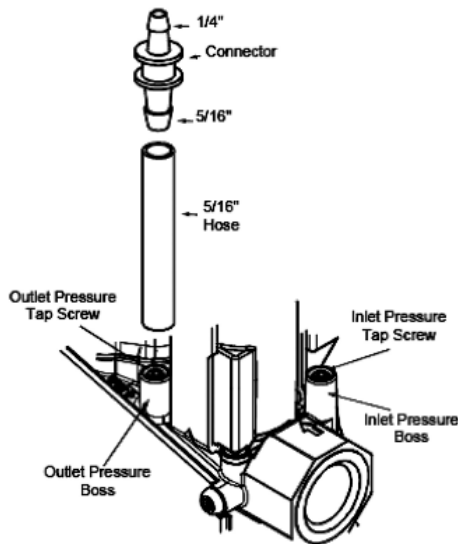
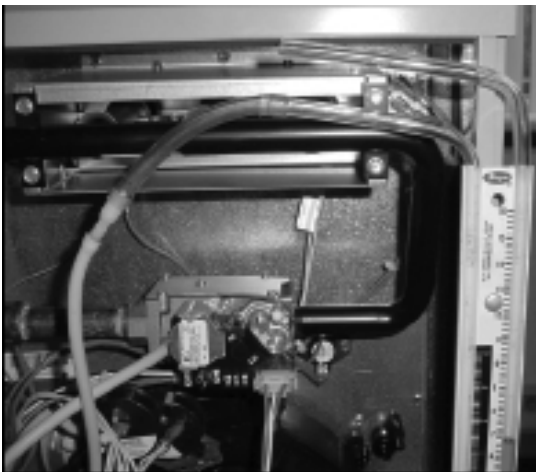

Figure 33 - Manometer Measuring Gas Inlet Pressure



Setting The Manifold Gas Pressure

When the installation is completed to the "Start-up & Setup" stage, test the gas manifold pressure by following these steps:

White-Rodgers 36G54 Two Stage Gas Valve.

1. Turn off the gas and electrical supply before proceeding.
2. Back outlet pressure test screw (outlet pressure boss, see fig.31) out one turn (counterclockwise, not more than one turn) with a 3/32" Allen wrench. Attach a hose and calibrated U-tube manometer to the outlet pressure boss. Hose should overlap boss 3/8". The manometer must have a scale range of at least 0" to 15" of water column.
3. Turn on the gas supply and electrical power to the furnace and energize main solenoid by connecting R to W1 on the integrated control board. Do not energize the HI solenoid
4. Remove regulator cover screw from the low outlet pressure regulator adjust tower (fig.31) and turn the plastic regulator adjustment screw clockwise to increase manifold pressure or counterclockwise to reduce manifold pressure. Always adjust regulator according to original equipment manufacturer's specifications listed on the appliance rating plate. Replace regulator cover screw.
5. Energize main solenoid as well as the HI terminal by connecting R to W1 and W1/W2 on the integrated control board. Remove regulator cover screw from the high outlet pressure regulator adjust tower (fig.31) and turn the plastic regulator adjustment screw clockwise to increase manifold pressure or counterclockwise to reduce manifold pressure. Manifold pressure should be set to 1.5" w.c low fire, 3.5" w.c high fire for natural gas, 4.0" w.c low fire, 10.5" w.c high fire for LP gas. Always adjust regulator according to original equipment manufacturer's specifications listed on the appliance rating plate. When the correct pressure has been established, securely replace the regulator cover screw.
6. Turn off the gas and electrical supply to the furnace.

WARNING



ALL REGULATOR ADJUSTMENTS MUST BE DONE BY A TRAINED, QUALIFIED TECHNICIAN. IMPROPER MODIFICATIONS OR ADJUSTMENTS CAN RESULT IN FIRE OR EXPLOSION CAUSING PROPERTY DAMAGE, SEVERE PERSONAL INJURY OR LOSS OF LIFE.

18 - CONVERSIONS

7. Remove the manometer hose from the outlet pressure tap boss, and tighten the outlet pressure tap screw using the 3/32" Allen wrench. (clockwise, 7 in-lb minimum).
8. Turn on the gas supply and electrical power to the furnace.
9. Turn on system power and energize valve.
10. Using a leak detection solution or soap suds, check for leaks at pressure boss screw. Bubbles forming indicate a leak. SHUT OFF GAS AND FIX ALL LEAKS IMMEDIATELY

In some circumstances, high inlet pressure can be remedied with the use of an in-line appliance regulator. If an in-line appliance regulator is used, ensure that it has the capacity to adequately handle the gas volume required by the furnace and any other appliances receiving gas from the header serving the furnace.

19 - ELECTRICAL SPECIFICATIONS

Electrical Wiring & Connections

Before proceeding with the electrical connections, ensure that the available electrical supply is compatible with the voltage, frequency and phase listed on the appliance rating plate.

All furnaces are rated 120 vac, 60 Hz, 1 Ø. The amperage rating is 15 amps or less.

Each furnace requires a dedicated 20 amp over-current device, either a 20 amp circuit breaker or a 20 amp Type D time delay fuse. It is permissible to connect furnace accessories such as humidifier transformers, condensate pumps and electronic air cleaners. If adding accessory equipment to the furnace circuit, ensure that the combined amperages listed on the appliance rating plates does not exceed the rating of the over-current device.

In Canada, all electrical work must be in accordance with the latest edition of CSA-C22.1, Canadian Electrical Code Part 1, and any applicable local code.

WARNING



SHUT OFF ELECTRICAL POWER AT THE FUSE BOX OR SERVICE PANEL BEFORE MAKING ANY ELECTRICAL CONNECTIONS. FAILURE TO DO SO CAN CAUSE ELECTRICAL SHOCK RESULTING IN PERSONAL INJURY OR LOSS OF LIFE.

WARNING



- THE FURNACE CABINET MUST HAVE AN UNINTERRUPTED GROUND.
- A GROUND WIRE IS PROVIDED IN THE ELECTRICAL JUNCTION BOX.
- DO NOT USE GAS PIPING AS A GROUND.

FAILING TO GROUND THE FURNACE PROPERLY CAN RESULT IN ELECTRIC SHOCK RESULTING IN PERSONAL INJURY OR DEATH.

In the United States, all electrical work must be in accordance with the latest edition of the National Electrical Code, ANSI / NFPA 70.

Although a suitably located circuit breaker may serve as a service switch, a separate service switch is recommended. A separate service switch is necessary if the circuit breaker is in a location where accessing it would require getting close to the furnace, or if the furnace is located between the main electrical panel and the entry to the furnace room. The furnace switch (service switch) should be clearly labeled, and installed in a location where it is not likely to be mistaken as being a light switch or similar control.

Figure 34 - Electrical Connections/Molex Connector

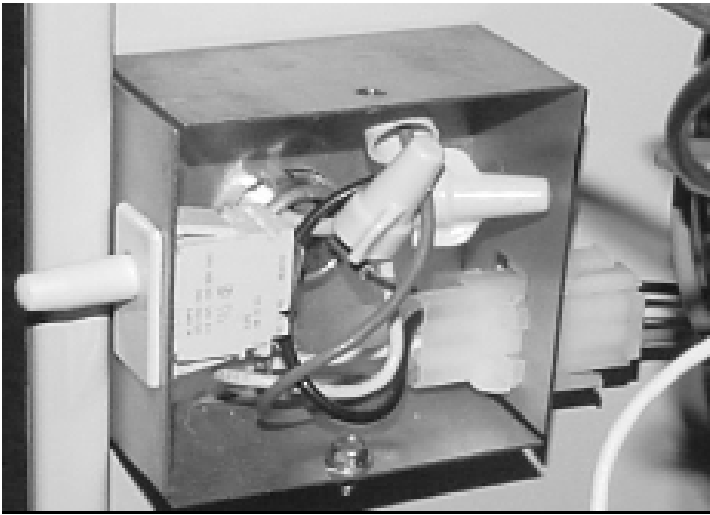
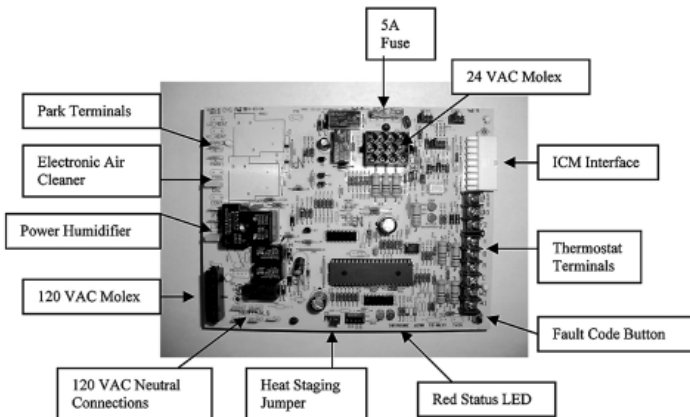

Figure 35 - Integrated Hot Surface Ignition Control



120V Furnace Connection

The furnace is shipped fully wired except for the connections to the house wiring. The furnace power connections are made in a junction box inside the blower compartment. The junction box is factory installed on the left hand side; however, it may be moved to the right hand side. The junction box contains a BLACK wire to be connected with L1 (hot), a WHITE wire to be connected with L2, the Neutral, and a GREEN wire to be connected to the ground.

NOTICE

NOTE: Use good quality wire nuts such as Marrette® connectors, Ideal® wire nuts, etc.

NOTICE

IMPORTANT: Use copper conductors only

If the junction box must be moved to the right hand side of the unit:

1. Unfasten the junction box from the left hand side.
2. Remove the right side panel knock-out.
3. Remove the junction box cover hook screw and re-install it on the opposite side of the box.
4. Fasten the junction box to the right hand panel.

NOTICE

L1 (hot) and L2 (neutral) polarity must be observed when making field connections to the furnace. The ignition control may not sense flame if L1 and L2 are reversed. The ground is also essential.

NOTICE

IMPORTANT: Electrical wiring and components must be protected from moisture including water and condensate.

WARNING



THIS FURNACE IS EQUIPPED WITH A BLOWER DOOR SAFETY SWITCH. DO NOT DISABLE THIS SWITCH. FAILURE TO FOLLOW THIS WARNING CAN RESULT IN ELECTRICAL SHOCK, PERSONAL INJURY, OR LOSS OF LIFE.

The low voltage terminals are located in the control box mounted to the blower assembly. The furnace is air conditioning ready. Insert the thermostat and air conditioner contactor low voltage wiring through a knockout provided in the side panel above the supply voltage knockout using a field supplied bushing. Route the control wiring to the control panel to connect to the 24 volt terminal screws.

Thermostat

The room thermostat must be compatible with the integrated control in the furnace. Electro-mechanical thermostats should be rated 30 V / 1.5 amps.

Figure 36- Isolation Relay

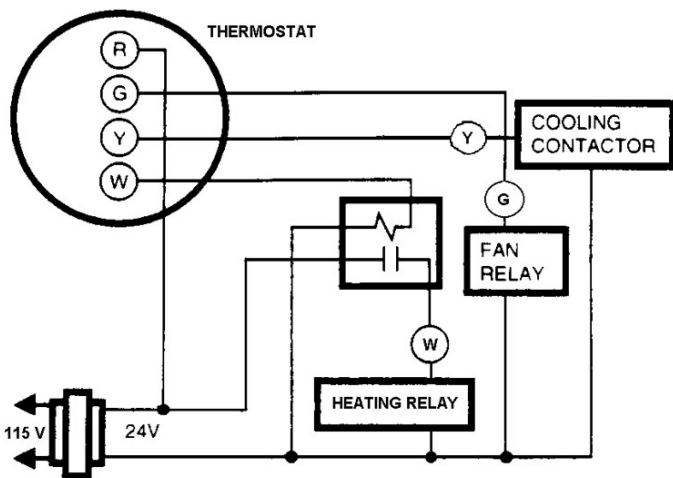

Most electronic or microprocessor based thermostats except those with “current robbing” circuits should work satisfactorily. Consult the instructions of the thermostat manufacturer for technical and installation details.

Most compatibility problems can be overcome by the use of an isolation relay. The isolation relay should be SPST with a 24 volt coil. The switch ratings should be a minimum of 0.5 amps. (Figure 36)

The thermostat and control wiring should be a minimum of 18 AWG copper. Excessive lengths of wire may result in enough voltage drop to impair the proper functioning of the furnace. For thermostat wires in excess of 25 feet, use 16 AWG; 50 feet, use 14 AWG.

Single Stage Thermostat

The automatic heat staging option allows a single stage thermostat to be used with a two stage furnace. The control provides a movable jumper (P5) to select between 5 minute and *10 minute automatic staging. Automatic staging time begins when the blower is energized after the heat blower delay period. If the jumper is in the 5 minute position, the control will automatically start high heat after 5 minutes of continuous low heat operation. If the jumper is in the *10 minute position, the control will automatically start high heat after 10 minutes of continuous low heat operation. Once high heat is started from automatic staging, the demand for high heat remains until the heat call is satisfied.

* Factory Setting

Two Stage Thermostat

When connecting a two stage thermostat, the jumper (P5) must be in the “NONE” position. The control runs high heat from the thermostat W2 demand.

Thermostat Location

The thermostat should be located approximately 5 feet above the floor, on an inside wall where there is good natural air circulation, and where the thermostat will be exposed to average room temperatures. Avoid locations where the thermostat will be exposed to cold drafts, heat from nearby lamps or appliances, exposure to sunlight, heat from inside wall stacks, etc.

Thermostat Heat Anticipator Setting: 0.1 AMP (Honeywell)

21 - OPTIONAL ACCESSORIES (FIELD SUPPLIED/INSTALLED)

Electronic Air Cleaner

The integrated furnace control has provisions to supply power and control an electronic air cleaner rated at 120vac, 1.0 amp max. 120 volt power will be available at these terminals whenever the circulating fan is operating in the heating or cooling modes.

Power Humidifier

The integrated furnace control has provisions to supply power and control a line voltage humidifier or the primary of a 120 / 24 volt humidifier step down transformer, rated at 120vac, 1.0 amp max.

NOTICE

All HUM and EAC terminals are 120V. Do not directly connect 24V equipment to these terminals.

22 - STARTUP PROCEDURES

This furnace is equipped with a HSI (Hot Surface Ignition) device. Each time that the room thermostat calls for heat, the HSI lights the main burners directly. See the lighting instructions on the furnace.

To Start The Furnace

1. Remove the burner compartment access door.
2. Shut off the electrical power to the furnace and set the room thermostat to its lowest setting.

NOTICE

IMPORTANT: Ensure that the manual gas control switch has been in the "OFF" position for at least 5 minutes. Do not attempt to manually light the main burners.

3. Turn the gas control switch to the "ON" position.
4. Replace the burner compartment access door.
5. Restore electrical power to the furnace.
6. Set the room thermostat to a point above room temperature to light the furnace.
7. After the burners are lit, set the room thermostat to the desired temperature.

To Shut Down The Furnace

1. Set the room thermostat to its lowest setting.
2. Remove the burner compartment access door.
3. Turn the gas control switch to the "OFF" position.
4. The furnace appliance shut-off valve may be closed if desired.
5. Power to the furnace must remain on for the air conditioner to work.

WARNING

 SHOULD OVERHEATING OCCUR OR THE GAS BURNERS FAIL TO SHUT OFF, CLOSE THE MANUAL GAS VALVE FOR THE FURNACE BEFORE SHUTTING OFF THE ELECTRICAL POWER TO THE FURNACE. FAILURE TO DO SO CAN CAUSE AN EXPLOSION OR FIRE RESULTING IN PROPERTY DAMAGE, PERSONAL INJURY OR LOSS OF LIFE.

BEFORE RESTARTING THE FURNACE, CHECK ALL PLASTIC VENTS AND WIRES FOR DAMAGE.

NOTICE

NOTE: On initial startup, the drain trap assembly will be dry. A dry trap will allow flue gases to flow through the recovery coil drain, which will prevent the condensate from draining from the recovery coil. If enough condensate accumulates in the recovery coil, the recovery coil pressure switch will sense this condition and break its electrical contacts, and extinguish combustion. If this takes place, the induced blower will stop after a brief post-purge cycle, the condensate will drain out and fill the trap. If the thermostat is still calling for heat, the ignition sequence will start again after a 5 minute wait.

Sequence Of Operation

1. Room temperature drops causing the room thermostat to call for first stage heat by connecting “W1” to “R”. The control verifies the limit switch is closed and both low and high pressure switches are open. The control energizes the induced draft motor on high speed and waits for the low pressure switch to close. The inducer remains on high speed and begins a 15 second pre-purge period. The high pressure switch is ignored. If the low pressure switch does not close within 60 seconds, the control will flash “2” on the red Status LED, and de-energize the inducer for 60 minutes.
2. When the 15 second pre-purge time has elapsed, the control energizes the HSI output for a 5 second warm-up period (10 seconds on retries). The control energizes the low main gas valve. 4 seconds after the gas is energized, the control de-energizes the HSI output and leaves the gas energized another 1 second for flame proving. If flame is present at the end of trial for ignition time, the control leaves the gas valve energized, inducer on high speed, and begins heat blower on delay. The control always ignites on high inducer/low gas and ignores second stage call for heat until low heat is established for 15 seconds.
3. Blower on delay time begins when the gas valve is energized. The control provides the ECM (Electronically Commutated Motor) low heat speed signal when flame is proven, and starts a 30 second soft start (slowly ramp up) blower delay before full capacity blower level.
4. When there is a demand for 2nd stage heat from thermostat W2 or automatic staging, the control changes the inducer from low to high speed. When high pressure switch closes, the control changes indoor blower speed from Low heat to High heat and energizes high gas output. If the High pressure switch is open the Green LED will flash. If the High pressure switch is closed the Green LED will be on. High gas valve drops out while High pressure switch is open because it is directly in series with the High pressure switch.
5. When the thermostat W2 call ends and W1 remains (two stage thermostat), the control de-energizes the high gas output and immediately changes inducer speed from high to low. With the thermostat heating contacts open (single stage thermostat), the flames extinguish immediately and the inducer blower stops after a 5 second post purge time.
6. Blower off delay is handled by the ECM (Electronically Commutated Motor). The control de-energizes the ECM heat signal when the gas valve de-energizes, and starts a programmed soft stop (slowly ramp down) delay period.

In The Event Of Flame Failure:

If flame is lost, the control de-energizes the gas valve within 2 seconds, switches the induced draft motor to high speed (if not already on high), and begins timing the inter-purge delay. The indoor blower

motor will be energized and/or remain energized on heat speed for the programmed delay off time. When the inter-purge delay is over, the control will re-cycle up to 5 flame losses (4 re-cycles) within a single call for heat before going into lockout. The control flashes “8” on the red LED if lockout is due to too many flame losses.

Checking Furnace Input

The natural gas supply pressure should be a maximum of 7” w.c. and minimum of 5” w.c. The burner manifold pressure is factory set to 3.5” w.c. High Fire, 1.5” w.c. Low Fire. The input rating of the furnace is based on 1000 BTU/cu. ft. gas with a specific gravity of 0.6.

Since heating values for the gas vary geographically, the actual furnace input and output will vary accordingly. For example, natural gas with a 1000 BTU/cu. ft. heating value will reduce the input to 93% of the rated input. Natural gas with a 1100 BTU/cu. ft. heating value will increase the input to approximately 103% of the rated input. This is not usually a problem; however, adjustments to compensate for this can be made by minor adjustments to the burner manifold pressure or by changing the burner orifice size.

Any adjustments to the burner manifold pressure should be carried out with the use of a manometer or calibrated magnehelic gauge. Do not adjust the gas valve pressure regulator more than ±0.3” w.c.

NOTICE

IMPORTANT: Never adjust the input of the furnace to exceed the input shown on the rating plate, which should be followed to ensure proper installation and operation.

In the previous example where the heating value of the gas is 1100 BTU/cu. ft., the burner manifold pressure can be reduced 3% to 3.4” w.c., which is within the ±0.3” w.c. specification to bring the input into compliance. Refer also to “Setting the Gas Manifold Pressure” and “High Altitude in the Gas Supply & Piping” section of this manual. Contact the fuel supplier for specific gas heating content values.

$$\text{Input} = \frac{\text{Heating Value of Gas} \times 3600}{\text{Time in Sec. for 1 cu. ft.}}$$

where:

- input is expressed in BTU/Hr
- heating value of the gas is expressed in BTU/ft³
- and time is the number of seconds required for the test dial to indicate 1 cubic foot.

If using a gas meter with SI (metric) units:

- 1 cubic foot = 0.0283 cubic meters
- 1 cubic meter = 35.315 cubic feet
- 0.01 cubic meter = 0.3531 cubic feet
- 0.5 cubic meter = 1.766 cubic feet

For proper furnace operation, air flow over the heat exchanger is of utmost importance. Insufficient airflow accelerates metal fatigue and failure in the heat exchanger and excessive airflow promotes accelerated corrosion of the heat exchanger.

NOTICE

IMPORTANT: Do not bypass this step of the start up procedures.

TABLE 1A - RANGE OF TEMPERATURE RISE

Furnace Model	Temperature Rise
60, 80, 100, 120	High Fire (HF) 35 - 65°F
	Low Fire (LF) 25 - 55°F

TABLE 1B - AIR FLOW FOR TEMPERATURE RISE

Furnace Model	High Fire (HF) CFM Required for a ΔT of:			
	35	45	55	65
60	1501	1167	955	808
80	2001	1557	1274	1078
100	2502	1946	1592	1347
120	3002	2335	1910	1616
Furnace Model	Low Fire (LF) CFM Required for a ΔT of:			
	25	35	45	55
60	901	700	573	485
80	1201	934	764	647
100	1501	1167	955	808
120	1801	1401	1146	970

Temperature Rise Check

When the duct system is complete and the air filter or filters are in place, determine if the airflow is correct for both low and high fire input rates..

1. Insert a duct thermometer in the supply air duct. The thermometer should be placed as close as practical to the furnace, but out of the "line of sight" of the heat exchanger (this prevents false readings owing to radiant heat). Ensure that the thermometer location is within the duct air stream. Avoid locations such as the inside radius of an elbow, etc.

TABLE 10 - AIR FLOW

MODEL 95V		ESP 0.1" to 1.0" w.c.		
Input	A/C Tonnage	ADJUST Jumper	COOL Jumper	CFM
60000	3 Ton	NORM	A	1200
			B	1000
			C	800
			D	600
80000	3 Ton	NORM	A	1200
			B	1000
			C	800
			D	600
80000	4 Ton	NORM	A	1600
			B	1200
			C	1000
			D	800
100000	5 Ton	NORM	A	2000
			B	1600
			C	1200
			D	800
120000	5 Ton	NORM	A	2000
			B	1600
			C	1200
			D	800

Note: Moving the ADJUST jumper from the NORM position to the (+) or (-) position will increase or lower the CFM by 15%

2. Insert a duct thermometer in the return air duct as close to the furnace as practical. Ensure that the thermometer location will be unaffected by humidifier bypass ducts, etc. Choose a location well within the main air stream.
3. Operate the furnace long enough to obtain steady state conditions at both input rates (High Fire and Low Fire).
4. When the two thermometers have stabilized, usually within 5-8 minutes, compare the two readings. Subtract the return air temperature from the supply air temperature. The difference is the temperature rise, also called ΔT .
5. Compare the measured ΔT to the temperature rise range shown on the rating plate. Unless stated differently on the rating plate, the temperature rise should normally range between 35° to 65°F High Fire, 25° to 55°F Low Fire. When adjusting the temperature rise, the ideal temperature is approximately mid-range. If the measured ΔT is above the approved temperature range, there is too little air flow. It must be increased by selecting the appropriate "HEAT" jumper setting, removing restrictions in the ductwork, or adding supply or return ductwork. If the measured ΔT is too low, there is too much air flow.

Calculating Air Flow

There are circumstances where it may be desirable to know the air flow delivery through the duct system, such as when estimating the amount of air flow available for air conditioning. This can be done by direct measurement with electronic or sloped manometers and velometers, or by counting the number of times the amber CFM LED on the control board flashes. Each flash signifies 100 CFM; count the flashes and multiply by 100 to determine the actual CFM delivered (for example: 10 flashes x 100 = 1000 CFM). Or use the formula in the next column.

$$CFM = \frac{\text{Output}}{1.085 \times \Delta T}$$

where:

- CFM is airflow in cubic feet per minute;
- ΔT is the temperature rise; and
- Output is the furnace output capacity from the rating plate.

NOTE: Output will vary directly with the input. If the actual input is below the stated input, the output will be reduced in the same ratio (93%).

Adjusting Blower Speeds

WARNING



DISCONNECT THE ELECTRICAL SUPPLY TO THE FURNACE BEFORE ATTEMPTING TO CHANGE THE BLOWER SPEED. FAILURE TO DO SO COULD RESULT IN ELECTRICAL SHOCK RESULTING IN PERSONAL INJURY OR LOSS OF LIFE.

This unit is factory set to run at the middle of the heating temperature rise range as listed on the rating plate. The cooling speed is set to the maximum airflow designated in the model number.

Three sets of 4 position movable jumpers are provided for Heat, Cool, and Adjust taps for a variable speed motor. These tap jumpers apply signals to the ECM motor without other interaction with the control board.

TABLE 11A - HEATING SPEEDS

ALL MODELS		ESP 0.1" to 1.0" w.c.	
HEAT Jumper	ADJUST Jumper	Low-Fire ΔT Range 25-55 °F	High-Fire ΔT Range 35-65 °F
A	NORM	40 °F	50 °F
B	NORM	35 °F	45 °F
C	NORM	45 °F	55 °F
D	NORM	50 °F	60 °F

Note: Moving the ADJUST jumper from the NORM position to the (+) or (-) position will increase or lower the temperature rise by 15%

TABLE 11B - HEATING CFM

95V060-3		ESP 0.1" to 1.0" w.c.	
HEAT Jumper	ADJUST Jumper	Low-Fire CFM	High-Fire CFM
A	NORM	700	1050
B	NORM	850	1105
C	NORM	575	880
D	NORM	525	819

TABLE 11C- HEATING CFM

95V080-4		ESP 0.1" to 1.0" w.c.	
HEAT Jumper	ADJUST Jumper	Low-Fire CFM	High-Fire CFM
A	NORM	1000	1350
B	NORM	1150	1495
C	NORM	900	1206
D	NORM	800	1104

TABLE 11D HEATING CFM

95V120-5		ESP 0.1" to 1.0" w.c.	
HEAT Jumper	ADJUST Jumper	Low-Fire CFM	High-Fire CFM
A	NORM	1650	2200*
B	NORM	1900	2200*
C	NORM	1500	2070
D	NORM	1325	1815

* Motor CFM maximum

TABLE 11E HEATING CFM

95V080-3		ESP 0.1" to 1.0" w.c.	
HEAT Jumper	ADJUST Jumper	Low-Fire CFM	High-Fire CFM
A	NORM	1050	1376
B	NORM	1250	1400*
C	NORM	900	1242
D	NORM	780	1108

* Motor CFM maximum\

TABLE 11E HEATING CFM

95V100-5		ESP 0.1" to 1.0" w.c.	
HEAT Jumper	ADJUST Jumper	Low-Fire CFM	High-Fire CFM
A	NORM	1200	1620
B	NORM	1400	1820
C	NORM	1100	1474
D	NORM	950	1349

Note: Moving the ADJUST jumper from the NORM position to the (+) or (-) position will increase or lower the temperature rise by 15%

If the blower speeds require adjustment, follow these steps:

1. Remove the blower compartment door.
2. Locate the 4 position movable HEAT jumper to adjust heat speed.
3. Remove the jumper from position A and place it on the corresponding letter B, C, or D as required. Refer to **TABLE 11A-11E HEATING-SPEEDS**.

NOTICE

NOTE: Temperature rise should always be re-checked whenever blower speed is changed.

4. To adjust the cooling airflow, remove the COOL jumper from position A and place it on the corresponding letter B, C, or D. Refer to **TABLE 10 AIR FLOW**.

Moving the ADJUST jumper from the NORM to the (+) or (-) position will cause the airflow to be increased or lowered by 15%.

The TEST position on the ADJUST tap is not used.

Dehumidification:

For situations where humidity control is a problem, a dehumidification feature has been built into the variable speed motor. At the start of each cooling cycle, the variable speed motor will run at 82% of the rated airflow for 7.5 minutes. After 7.5 minutes has elapsed, the motor will increase to 100% of the rated airflow. If this feature is not desired, clip the jumper wire between Y and O on the integrated furnace control board. With Y and O not jumpered, the variable speed will reach 100% of the rated airflow within 10 seconds of a call for cooling.

Additional dehumidification can be achieved by connecting a humidistat to the DEHUM and R terminals on the integrated furnace control board. In this setup, the variable speed motor will operate at a 10% reduction in the normal cooling airflow rate when there is a call for dehumidification.

Both dehumidification methods described above can be utilized on the same furnace.

Setting Blower "On" And "Off" Timings

Blower on/off delays are handled by ECM motor programming. The control de-energizes the ECM heat signal when the gas valve de-energizes. Features of this ECM variable speed motor are that it will deliver a constant airflow within a wide range of external static pressures, and also includes:

Soft Start: This ECM variable speed motor will slowly ramp up to the required operating speed. This feature in the heating cycle allows the heat exchanger to reach operating temperature before the set heat speed, which minimizes noise and increases comfort.

Soft Stop: At the end of the heating or cooling cycle, the ECM variable speed motor will slowly ramp down. This feature allows for increased energy efficiency, and reduced noise levels.

Continuous Fan Operation

When the thermostat continuous fan (G) switch is on without a call for heat or cooling, the indoor fan is immediately energized up to 50% of the cooling speed. The fan remains energized as long as the call for fan remains without a call for heat or cooling. This feature allows continuous circulation of air between calls for heating or cooling.

If a call for heat (W) occurs during continuous fan, the blower will de-energize.

23 - AIR FLOW

If a call for cool (Y) occurs simultaneously with the call for fan (G), the call for cool overrides the call for fan and the blower remains off for the cooling on delay period.

TABLE 12 - CONTINUOUS FAN CFM

MODEL	Motor HP	COOL Jumper	ADJUST Jumper	Continuous Fan (CFM)
95V060-3	1/2	A	NORM	600
95V080-3	1/2	A	NORM	600
95V080-4	3/4	A	NORM	825
95V100-5	1	A	NORM	865
95V120-5	1	A	NORM	930

Note: Moving the ADJUST jumper from the NORM position to the (+) or (-) position will increase or lower the continuous fan CFM by 15%

24 - MAINTENANCE AND TROUBLESHOOTING

WARNING



DISCONNECT THE ELECTRICAL POWER SUPPLY TO THE FURNACE BEFORE ATTEMPTING ANY MAINTENANCE. FAILURE TO DO SO CAN CAUSE ELECTRICAL SHOCK RESULTING IN PERSONAL INJURY OR LOSS OF LIFE.

CAUTION



Label all wires prior to disconnection when servicing controls. Wiring errors can cause improper and dangerous operation.

Always verify proper operation after servicing.

Recommended: Electronic air filters using electrostatic precipitation to remove dust are an excellent filtration device. A 16" x 25" model is an ideal fit with this furnace in the case of a side mounted return air inlet. The furnace control module is supplied with electrical terminals for use with electronic air cleaners.

A 16" x 25" x 1" filter kit part number 550001458 can be ordered for use on this appliance. This kit includes the filter rack and washable filter.

NOTICE

NOTE: If two return air inlets are used, both must be equipped with filters.

Air Filter

The filter should be inspected frequently and cleaned as necessary. We recommend a monthly inspection at first, perhaps coinciding with the arrival of the monthly fuel bill as a reminder. The frequency may be increased or decreased depending on experience and conditions.

Avoid the use of the fiberglass throw-away filters. They tend to block up quickly, which may result in higher than normal operating temperatures, and lower efficiency.

Some paper media high efficiency filters, sometimes identified as HEPA filters can do an effective and excellent filtration of the air; however, some models may also cause a large pressure drop across the filter. The contractor should assess the capabilities of the duct system to deliver sufficient air flow if this type of filter is considered.

CAUTION

Do not operate the furnace for prolonged periods of time without an air filter.



A portion of the dust entrained in the air may lodge in the supply air ductwork and registers. Any recirculated dust particles will be heated and charred by contact with the furnace heat exchanger. This residue will soil ceilings, walls, drapery, carpets, and other household articles.

Lubrication

Both the induced draft blower motor and circulating fan motor are ball-bearing type motors. Neither requires routine lubrication.

NOTICE

IMPORTANT: The motor bearings were pre-lubricated by the motor manufacturer. Do not attempt to lubricate them. Excess lubrication will void the warranty, shorten the service life if the motors, and will attract the buildup of dust and dirt.

The induced blower motor and circulating fan motor must be cleaned on a periodic basis by a qualified service technician. Dust buildup in the ventilation ports of the motor will cause the motor to not dissipate heat properly resulting in reduced service life.

Terminations

The combustion air and exhaust terminals should be inspected occasionally to ensure that they are free of obstructions and debris. If screens were used in either terminal, ensure that they are free of debris, corrosion, or anything preventing the free flow of air. In weather conditions when snow build-up occurs, the homeowner should inspect the vent terminal and air intake regularly to ensure they are free and clear of snow. Maintain at least one foot of clearance between snow build-up and vent/combustion air intake openings at all times. Clear away excess snow to maintain this clearance.

Figure 37 - Vent Terminal Clearance

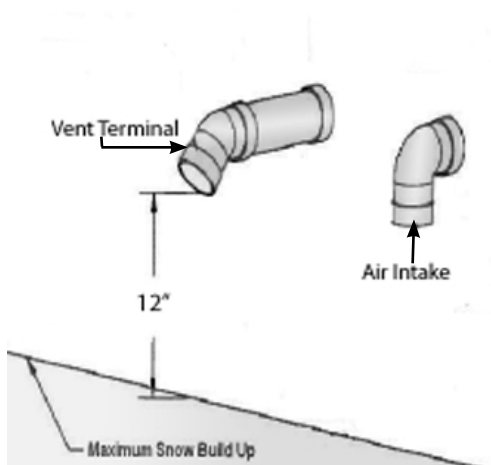

Intake Air/Exhaust Piping

The combustion air intake piping and exhaust piping should be inspected periodically for sags, evidence of leakage etc. If either condition exists, contact your installation contractor, service agency or fuel supplier.

WARNING



HOLES IN THE EXHAUST PIPING OR FURNACE HEAT EXCHANGER CAN ALLOW TOXIC FUMES TO ENTER THE HOME AND CIRCULATE THROUGH THE DUCT SYSTEM RESULTING IN CARBON MON-OXIDE POISONING OR DEATH. IF LEAKS ARE FOUND IN THE FURNACE HEAT EXCHANGER, IT MUST BE REPLACED.

Operating Tips

1. Clean air filters maximize efficiency and reduce heating costs.
2. During the heating season, keep windows and doors closed to reduce the heating load on the system.
3. Avoid excessive use of kitchen exhaust hoods and other exhaust fans to reduce the heating load on the system.
4. Arrange the furniture and drapes so that the supply air registers and return air grilles are unobstructed.
5. If you have a perimeter duct system, ideally, the warm air should bathe the cold exterior walls. Avoid the use of plastic deflectors on the supply air registers which tend to short circuit the warm air straight into the return air grilles. These deflectors are often the cause of cool draughts across the floor.
6. Avoid placing heat producing appliances such as televisions, radios, lamps, etc. in a location to influence the thermostat.
7. Keep combustible articles at least 3 feet away from the furnace. Do not block access for servicing the furnace. Do not use the combustion air or exhaust piping as a hanger for clothes or anything else.

NOTICE

IMPORTANT: Never attempt to operate the furnace without the blower door and combustion compartment door in place or when the blower has failed.

Annual Inspection/Service

The furnace must be inspected annually by a qualified installation contractor, service agency or fuel supplier. Your annual inspection will normally cover the following:

HEAT EXCHANGER - The heat exchanger should be inspected for corrosion. The flue passages (heat exchanger tubes) should be free of scale or excessive corrosion. The top row of heat exchanger tubing is accessible for cleaning with a small diameter wire-handled brush

by removing the burner assembly. The bottom row is only accessible if the heat exchanger is removed and the rear flue box cover is removed. The recovery coil (secondary heat exchanger) may be cleaned by accessing the rear flue box cover or removing the front manifold cover. After clearing accumulated scale, observe the burner flames. If there appears to be flame distortion, check the combustion air intake and exhaust piping and terminals for blockage. Also check for signs of soot in the condensate drainage. If flame distortion continues after eliminating the blockage in the piping as the cause, it may be necessary to replace the tubular heat exchanger.

NOTICE

NOTE: Prior to removal of rear flue box cover or front manifold cover, ensure that replacement gaskets are available to ensure proper sealing of the heat exchanger when re-assembled.

BURNERS - The burners should be inspected to ensure that they are free of deterioration, dust and debris, and properly aligned with the heat exchanger. In most cases, a simple vacuuming with a brush attachment will adequately clean the burner assembly and burner compartment.



CAUTION

Be careful when working on the burner assembly. The hot surface igniter is fragile and can break easily.

The flame sensor should be inspected and cleaned with fine steel wool or Scotch-Brite™ scrubbing pad. The wiring connection should be checked to ensure that it is tight and corrosion free.

NOTICE

NOTE: This is a critical connection. Small amounts of corrosion can significantly increase the internal resistance of the connection. A relatively small increase in resistance can result in a large decrease in flame signal.

DRAINAGE - The condensate drainage system should be inspected and cleaned if necessary. If the drain trap assembly, or any other component becomes blocked, condensate may backup into the secondary or primary heat exchanger causing nuisance trip-outs of the pressure switches or limit switch. The condensate should be observed for signs of dirt, carbon, debris, etc.

If a condensate neutralizer has been added to the condensate drain, it should be inspected, cleaned, or the condensate neutralizing media should be replaced to ensure clear condensate flow.

INDUCED BLOWER - The induced blower motor should be inspected and cleaned if necessary. Clear any dust buildup from the ventilation ports.

CIRCULATING FAN - The condition of the circulating fan should be checked to ensure that it is free of excessive dust buildup, debris, etc. The mechanical fasteners should be inspected and checked for proper tightness and parts alignment. The motor ventilation ports should be cleaned if necessary to prevent restriction to cooling by air over the motor.

ELECTRICAL - All electrical connections should be examined to ensure that they are tight and corrosion free. Repair any connections that have become loose or corroded.

FURNACE OPERATION - The furnace should be cycled during the annual inspection and servicing to:

1. Test all safety related controls.
2. Determine that the temperature rise falls within the range shown on the appliance rating plate.
3. Ensure that the burner ignition is smooth and that the flames are smooth soft blue, and not impinging on the heat exchanger.

25 - TROUBLESHOOTING FLOWCHART

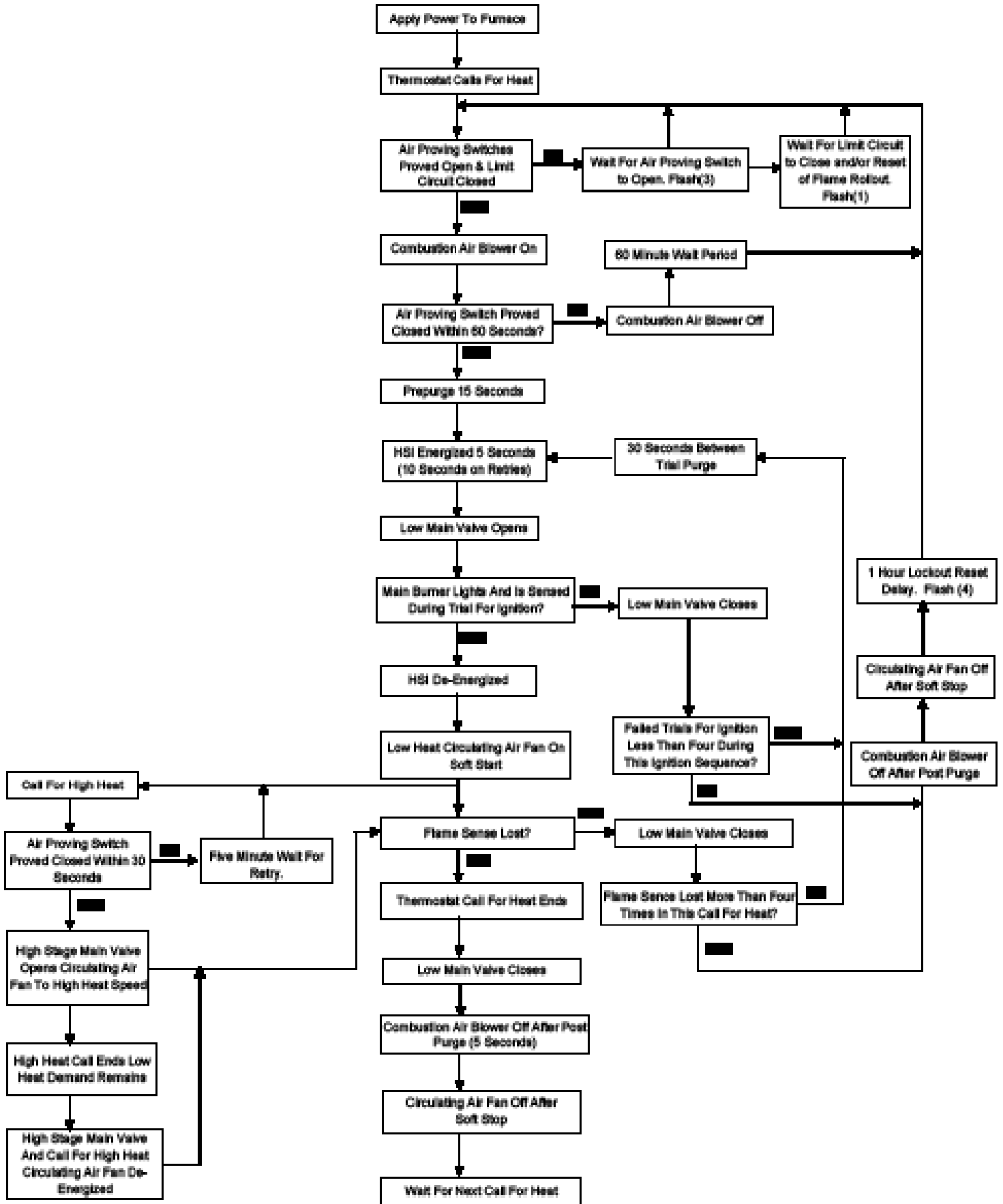

A RED LED is provided to indicate furnace operating status		
LED Condition	Fault Condition	Check
LED ON	Normal operation	No action required. Control OK.
LED OFF	No power to control or control hardware fault detected	Line voltage input power at L1 and Neutral connectors control board. System wire harness in good condition and securely connected at both ends.
1 Flash	High limit switch open	Open limit switch. Limit switch and wiring in good condition and securely connected. Check for blocked air filter, correct temperature rise, blower speed selection, closed ducts, ect.
2 Flashes	Pressure switches open with inducer on	Pressure switches operation, tubing and wiring. Obstruction or restrictions in venting preventing proper air flow.
3 Flashes	Pressure switches closed with inducer off	Pressure switches stuck closed. Pressure switches mis-wired or jumpered.
4 Flashes	Control in 1 hour lockout	Gas supply OFF, or gas supply pressure too low to operate furnace. Damaged or broken HSI element. Line voltage input power at L1 and Neutral connectors control board. Furnace not properly earth grounded. Flame sensor rod contaminated or in incorrect position. HSI element located in wrong position. Hot surface element or flame sensor wiring in good condition and properly connected.
5 Flashes	L1/Neutral Polarity problem	Check supply voltage to ensure proper polarity to L1 and Neutral connections.
6 Flashes	Not Used	
7 Flashes	Pressure switch cycle lockout	Pressure switches operation, tubing and wiring. Obstruction or restrictions in venting preventing proper air flow.

A RED LED is provided to indicate furnace operating status		
LED Condition	Fault Condition	Check
8 Flashes	Lockout due to too many flame dropouts	Check system for proper ground. Dirty, oxidized or failed flame sensor.
9 Flashes	Not used	
10 Flashes	Flame present with gas off	Flame at main burner. Gas valve.

A GREEN LED is provided to indicate high heat state	
LED off	No demand for high heat
LED on	High heat demand, operating normally
LED flashing	High heat demand, high pressure switch not closed

Fault Code History

The control stores the last 5 fault codes in memory. When the push-button switch is pressed for less than 5 seconds, the control will flash the stored fault codes when the switch is released. The most recent fault code is flashed first, the oldest last.

Fault history may be cleared by holding the push-button switch for more than 5 seconds.

VENTING CHECKLIST	✓
Vent pipe must be sloped to drain from outlet back to furnace.	
Exposed vents and drains must be heat traced.	
Vents exiting house must be well sealed to prevent exhausts from re-entering the house.	
Vents and intake must be 12" above grade. For Massachusetts see page 7.	
In Canada all venting material must be identified as ULC S636 and be readily accessible for visual inspection for the first 3ft. (900mm)	
Use large radius elbows where possible.	
Exhaust vents must not be near windows or other fresh air intakes.	
Support vents firmly. Keep out of work areas to prevent damage.	
Clamp and gasket all vent exits to furnace panels to insure airtight seal.	
Equivalent vent length must be less than the allowable length in Table 6 Direct and Non-Direct Vent Lengths.	
If there is a choice, the exhaust should be shorter than the intake vent.	
For indirect vent, installer must calculate size of room to determine if outside air is required.	
Use direct vent for commercial installations that use chemicals (Hair Salons, etc.)	
Avoid exposure to windy side of house.	
Heat Exchanger (suction) drain must be trapped separate from vent drain (pressure). A/C drain must not be inserted before heat exchanger and vent drain trap.	
Exhaust vent and combustion air intake must be located within the same wind pressure zone when installed in a direct vent application using outdoor combustion air.	

Replacement Parts List		
Item	Kit Number	Repair Parts List for 95% Two Stage High Efficient Furnace
1	550001515	FLAME ROLLOUT SWITCH 350°F, ALL MODELS
2	550001528	FLAME SENSOR, ALL MODELS
3	550001656	TWO STAGE GAS VALVE 36G54, ALL MODELS
WHITE RODGERS 36G54 TWO STAGE 24V GAS VALVE SET FOR NG		
4	550001514	LIMIT SWITCH 160°F 100-5, 120-5
	550001525	LIMIT SWITCH 150°F 60-3, 80-3, 80-4
5	550001655	INTEGRATED CONTROL BOARD, ALL MODELS
UT ELECTRONICS CONTROLS 1170-23		
6	550001533	TRANSFORMER 120V/24V SEC., ALL MODELS
7	550001527	HSI (HOT SURFACE IGNITOR), ALL MODELS
8	550001653	TWO SPEED INDUCED BLOWER, ALL MODELS
JAKEL AX3490 INDUCED BLOWER WITH GASKET AND TERMINATION		
9	550001649	PRESSURE SWITCH SET, ALL MODELS
MPL INC. HG-0.70" W.C. LF-0.30" W.C. FMC-0.30" W.C.		
10	550001522	FRONT MANIFOLD COVER 60-3, 80-3, 80-4
	PLASTIC FRONT MANIFOLD COVER WITH GASKETS	
	550001523	FRONT MANIFOLD COVER 100-5, 120-5
	PLASTIC FRONT MANIFOLD COVER WITH GASKETS	
11	550001660	"PFC" CHOKE COIL 80-4, 100-5, 120-5
12	550001532	DOOR SWITCH, ALL MODELS
13	550001657	1HP ECM MOTOR 120-5
	550001861	1HP ECM MOTOR 100-5
	550001658	1/2HP ECM MOTOR 60-3
	550001866	1/2HP ECM MOTOR 80-3
	550001659	3/4HP ECM MOTOR 80-4
14	550001520	BLOWER 12-7T W/WHEEL 60-3, 80-3, 80-4
	550001536	BLOWER 12-10T W/WHEEL 100-5, 120-5
15*	550001534	FUSE 5 AMP., ALL MODELS
16*	550001458	FILTER, ALL MODELS KIT INCLUDES: RACK, RAIL, 16" X 25" PERMANENT FILTER
17*	29570	CONCENTRIC VENT, 2" DIA.
18*	29571	CONCENTRIC VENT, 3" DIA.
19*	550001521	PARTS BAG HI, ALL MODELS
20*	550001654	WIRE HARNESS HIGH 2ST, ALL MODELS
ALL WIRE HARNESSES INCLUDED		
21*	550001815	MOTOR MOUNTING ARMS & HRDWR, ALL MODELS INCLUDES: 48 FRAME MOTOR MOUNTING BAND WITH FASTENERS, 3 - 12" DIAMETER MOTOR MOUNTING ARMS
22*	550001641	CONV. NG, LP, HIGH ALT, 95% 2ST, CAN/US, ALL MODELS
ALL FUELS AND ALTITUDES SPRINGS AND ORIFICES		
23*	550001816	CONV. LP, NG 95% 2ST, CAN/US, ALL MODELS
LP SPRINGS AND ORIFICES		
24*	550001648	CONV. NG, LP, 95% 2ST, CAN/US, ALL MODELS
NG SPRINGS AND ORIFICES		
25*	550001346	FLOOR SUB-BASE KIT, ALL MODELS

* Not Shown

REPLACEMENT PARTS LIST

HIGH EFFICIENCY TWO STAGE GAS FURNACE

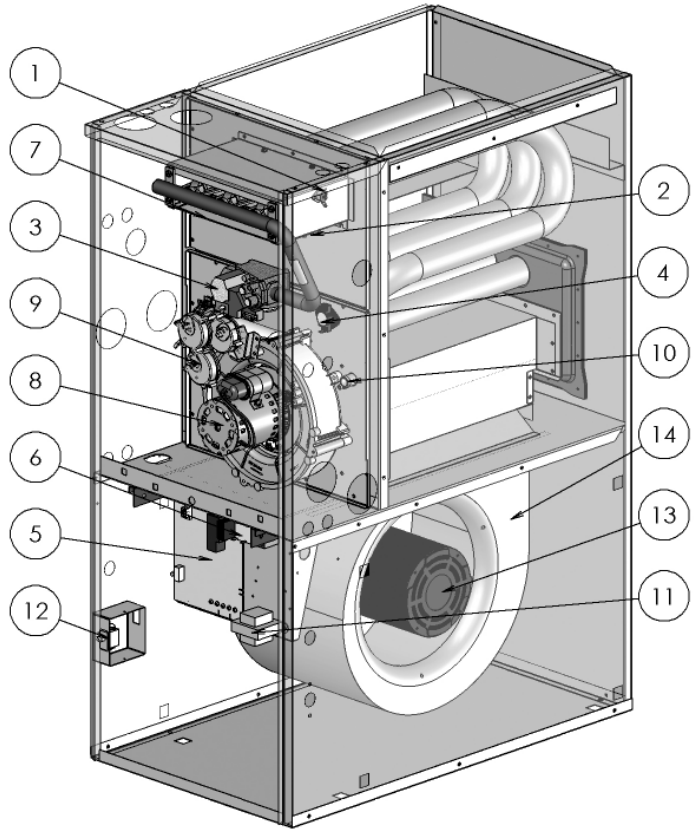

G95V
NATURAL AND PROPANE GAS TWO
STAGE HIGH EFFICIENCY (CONDENSING)
WARM AIR FURNACE

Olsen
Heating & Cooling Products

 **ecr**
innovative living™

ECR International
2201 Dwyer Avenue •
Utica • New York • 13504 • USA
www.ecrinternational.com