



**G95V**  
NATURAL AND PROPANE GAS TWO  
STAGE HIGH EFFICIENCY (CONDENSING)  
WARM AIR FURNACE

**USER'S INFORMATION MANUAL**



An ISO 9001-2008 Certified Company

**Manufactured by:**  
**ECR International, Inc.**  
2201 Dwyer Avenue, Utica NY 13501  
web site: [www.ecrinternational.com](http://www.ecrinternational.com)

P/N 240006752, Rev. D [04/2012]

**TABLE OF CONTENTS**

**Warnings And Safety Symbols .....3**  
**General Safety Issues.....4**  
**General Safety Rules.....5**  
**Furnace Operation Information.....6**  
**Routine Maintenance By Homeowner .....7**  
**Homeowner’s Reference .....11**

PLEASE READ THIS MANUAL CAREFULLY AND KEEP IN A SAFE PLACE FOR FUTURE REFERENCE BY A SERVICE TECHNICIAN.

**IMPORTANT: Read the following instructions COMPLETELY before attempting to operate this furnace!**

The following defined symbols are used throughout this manual to notify the reader of potential hazards of varying risk levels.

 **DANGER**  
Indicates an imminently hazardous situation which, if not avoided, WILL result in death, serious injury or substantial property damage.

 **WARNING**  
Indicates an imminently hazardous situation which, if not avoided, may result in death, serious injury or substantial property damage.

 **CAUTION**  
Indicates an imminently hazardous situation which, if not avoided, may result in injury or property damage.

**NOTICE**  
Indicates information which should be followed to ensure proper installation and operation.

This furnace has been designed to deliver many years of efficient, dependable service. With regular maintenance, some of which requires the attention of a qualified installer, service agency or gas supplier, some of which you may do yourself, the furnace will operate satisfactorily over many heating seasons.

Please read this manual to familiarize yourself with safety procedures, operation, and routine maintenance procedures.

 **WARNING**  
If the information in these instructions is not followed exactly, a fire or explosion may result, causing property damage, personal injury or loss of life.

**WARNING**

**FOR YOUR SAFETY**  
Do not store or use gasoline or other flammable vapors and liquids, or other combustible materials in the vicinity of this or any other appliance.

**WHAT TO DO IF YOU SMELL GAS**  
Do not try to light any appliance.  
Do not touch any electrical switch; do not use any phone in your building.  
Immediately call your gas supplier from a neighbor's phone, or a cellular phone from a location well away from the building. Follow the gas supplier's instructions.  
If you cannot reach your gas supplier, call the fire department.  
Do not re-enter the building until authorized to do so by the gas supplier or the fire department.

 Improper installation, adjustment, alteration, service or maintenance can cause injury, property damage or loss of life. Refer to this manual.

Installation and service must be performed by a qualified installer, service agency or the gas supplier.

 **WARNING**  
SHOULD OVERHEATING OCCUR OR THE GAS BURNERS FAIL TO SHUT OFF, CLOSE THE MANUAL-GAS VALVE FOR THE FURNACE BEFORE SHUTTING OFF THE ELECTRICAL POWER TO THE FURNACE. FAILURE TO DO SO CAN CAUSE AN EXPLOSION OR FIRE RESULTING IN PROPERTY DAMAGE, PERSONAL INJURY OR LOSS OF LIFE. BEFORE RESTARTING THE FURNACE, CHECK ALL PLASTIC VENTS AND WIRES FOR DAMAGE.

## GENERAL SAFETY ISSUES

### WARNING



IMPROPER INSTALLATION, ADJUSTMENT, ALTERATION, SERVICE OR MAINTENANCE CAN CAUSE PROPERTY DAMAGE, PERSONAL INJURY OR DEATH. FOR ASSISTANCE OR ADDITIONAL INFORMATION, CONSULT A QUALIFIED INSTALLER, SERVICE AGENCY, OR YOUR GAS SUPPLIER.

### General Safety Issues

Most natural gas systems and all LP gas systems have a service regulator located near the point where the gas piping enters the building.

The propane tank will normally have an additional first stage regulator located at the tank outlet valve. All of these regulators (located outdoors) will have a vent. (Figure 1)

### WARNING



DEVICES ATTACHED TO EITHER THE VENT OR COMBUSTION AIR INTAKE FOR THE PURPOSES OF EXCEEDING THE LIMITATIONS DESCRIBED IN THE INSTALLATION MANUAL, INCLUDING FIELD INSTALLED INDUCED BLOWER FANS HAVE NOT BEEN TESTED AND ARE NOT INCLUDED IN THE DESIGN CERTIFICATION OF THE FURNACE. THE MANUFACTURER CANNOT AND WILL NOT SPECULATE ON THE EFFECTS OF SUCH MODIFICATIONS AND CANNOT AND WILL NOT BE RESPONSIBLE FOR INJURY OR DAMAGE CAUSED BY THE USE OF SUCH UNTESTED AND/OR UN-CERTIFIED DEVICES, ACCESSORIES OR COMPONENTS.

Figure 1 - Gas Regulator Vent

REGULATOR VENT  
Keep free of ice,  
snow, and debris.



It is important for these vents to remain clear. Do not allow moisture, which could freeze, to build up in the vent. If you see moisture building up in the regulator vent, contact your gas supplier.

### WARNING



OBSTRUCTION OF THE AIR VENT ON AN LP (PROPANE) CYLINDER OR TANK REGULATOR CAN CAUSE EXPLOSION OR FIRE RESULTING IN PROPERTY DAMAGE, SEVERE PERSONAL INJURY OR DEATH.

YOUR GAS SUPPLIER SHOULD PERIODICALLY INSPECT AND CLEAN THE AIR VENT SCREEN TO PREVENT ANY OBSTRUCTION. KEEP PROTECTIVE REGULATOR COVER IN PLACE, AS EXPOSURE TO THE ELEMENTS CAN CAUSE ICE BUILDUP AND REGULATOR FAILURE.

### General Safety Rules

1. Combustible materials should not be stored against or around the furnace. Keep the furnace area clear and free from all combustible materials such as newspapers, rags, cardboard, foam, plastic, paper backed fiberglass insulation, clothing, etc. This applies especially to gasoline and other flammable vapors and liquids.
2. A furnace needs adequate amounts of combustion and ventilation air to operate properly. Do not block or obstruct air openings on the furnace, or air openings supplying combustion or ventilation air to the area where the furnace is installed. There are many areas from which your furnace could be receiving combustion and ventilation air including from within the heated area (inside air), from outdoors, from an attic or crawl space. If renovations are done, be sure that air supply openings are not inadvertently covered over with insulation, vapor barrier, or similar construction material.
3. All doors and panels must be in place during normal furnace operation. Attempting to operate the furnace with missing doors or panels could lead to the creation of carbon monoxide gas.
4. If the furnace is installed in a confined space or if you intend to build a furnace room where insulation is present, be aware that some insulating materials are combustible. Do not allow building insulating materials to come into contact with the furnace.
5. Any additions, alterations or conversions required in order for the furnace to properly match the application requirements must be done by a qualified installation contractor, service agency or gas supplier, using factory specified or approved parts.
6. Familiarize yourself with the location of the furnace gas manual shut-off valve and any electrical switches, fuse or circuit breaker associated with the furnace.
7. Should over-heating occur, or if the gas valve fails to shut off the burners, shut off the gas supply with the furnace manual shut-off valve, then shut off the electrical supply to the furnace. In the case of the latter, call a qualified installation contractor, service contractor, or gas supplier.
8. If the furnace has been subjected to flood conditions, i.e., if any part of the furnace has been under water, call a qualified installer, service agency or gas supplier for a complete inspection. Electronic controls and gas train components may become unstable and unreliable. The furnace must not be used until the furnace has been checked, and any affected parts have been replaced.
9. Familiarize yourself with the location of your furnace filter or filters. A blocked air filter will reduce efficiency, increase fuel consumption, raise the furnace operating temperature, and shorten the life of furnace components.
10. Do not cover return air grills and supply air registers with drapes, curtains, throw rugs, etc.
11. Avoid shutting off supply air registers in the interests of saving heat. While there is some validity to this practice with space heating, there is little to be gained in central heating systems. The furnace requires a quantity of air passing over the heat exchanger to operate within design temperatures. Reducing the number of supply air registers available for air delivery may have the unforeseen consequence of raising the furnace operating temperature, reducing furnace efficiency, and shortening the life of the furnace components.

## FURNACE OPERATION INFORMATION

During the heating season, the operation of the furnace is fully automatic.

### TO START THE FURNACE:

1. First read these instructions and safety notices thoroughly.
2. Set the thermostat to the lowest setting.
3. Ensure that all supply air registers and return air grilles are open.

If this is the first time that the furnace has undergone a trial ignition since installation, or if there has been work done on the gas lines, the furnace might not light because of air trapped in the gas supply line.

Simply turn the thermostat down to its lowest setting, wait 5 minutes, then adjust the thermostat to the desired setting. If the problem persists, proceed to “Furnace Shut-Down Procedure” and call your Installer, service agency or gas supplier.

Figure 2 - White Rodgers 36G54 Gas Valve

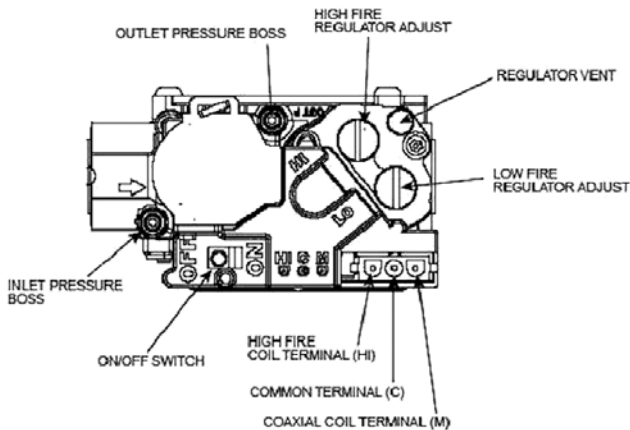

### FURNACE SHUT-DOWN PROCEDURE:

1. Set the thermostat to its lowest setting.
2. Shut off electric power to the furnace.
3. Turn the appliance manual shut-off valve to the “OFF” position.
4. Remove the burner access door, turn the manual gas control switch to the “OFF” position, then re-install the burner access door.

#### NOTICE

If you intend to be away from home for lengthy periods of time during the non-heating season, it is advisable to follow the furnace shut down procedure.

4. Turn off the electric power to the furnace.
5. Remove the burner access door.
6. Ensure that the appliance manual shut-off valve is in the “ON” position. The valve handle is normally in-line with the gas pipe and valve body when it is in the “ON” position; perpendicular to the gas piping and valve body when it is in the “OFF” position.
7. Turn the manual gas control switch to the “OFF” position. (Figure 2)
8. Wait 5 minutes to clear out any gas. If, after this time you smell gas, STOP. Turn the appliance manual shut-off valve to the “OFF” position. If burning propane or other LP gas, smell for gas near the floor since propane and butane are both heavier than air. If after this time you do not smell gas, continue to the next step.
9. Turn the manual gas control switch to the “ON” position.
10. Replace the burner access door, ensuring that it is properly in place.
11. Restore the electric power to the furnace.
12. Adjust the thermostat to the desired setting. If the thermostat also controls an air conditioning system, ensure that the thermostat system switch is in the “HEAT” or “AUTO” mode.

**Air Filter**

**CAUTION**

Do not operate your furnace or air conditioner for extended periods of time without an air filter.

A portion of the dust entrained in the air may temporarily lodge in the air duct runs and the supply registers. Any recirculated dust particles will be heated and charred by coming into contact with the heat exchanger. This residue will soil ceilings, walls, drapes, carpets, furniture, and other household articles.

**WARNING**

DISCONNECT THE ELECTRICAL POWER TO THE FURNACE BEFORE ATTEMPTING ANY MAINTENANCE. FAILURE TO DO SO MAY CAUSE ELECTRICAL SHOCK RESULTING IN SEVERE PERSONAL INJURY OR DEATH.

Follow air filter manufacturer's instructions for removing and cleaning the filter. Allow the filter to dry thoroughly before reinstallation and never operate the blower fan with a wet filter. Consult your installation contractor or service technician if you have any questions on filters.

**CAUTION**

If cleaning rather than replacing the filter, unless the filter is thoroughly washed and dried, be sure that the filter is reinstalled with the airflow direction identical to its previous use. Reversing the filter will cause dust trapped within the filter to break free and recirculate within the duct system.

**Lubrication**

The circulating air blower, and induced blower assembly motors have sealed bearings. The bearings contain permanent special purpose lubricants. Attempting to force common oil into the circulating and induced blower motor bearings will deteriorate the original lubricant and shorten bearing life.

**Routine Examination**

**NOTICE**

We recommend that your furnace and vents be checked by a qualified service technician once a year.

Do not allow snow, ice or debris to accumulate around the outdoor furnace exhaust and combustion air intake terminals. Blockage of the exhaust or combustion intake terminals can result in inadequate performance or nuisance shut-downs. In weather conditions when snow build up occurs, the homeowner should inspect the vent terminal and air intake regularly to ensure they are free and clear of snow. Maintain at least one foot of clearance between snow build-up and vent/combustion air intake openings at all times. Clear away excess snow to maintain this clearance.

**Figure 3 - Vent Terminal Clearance**

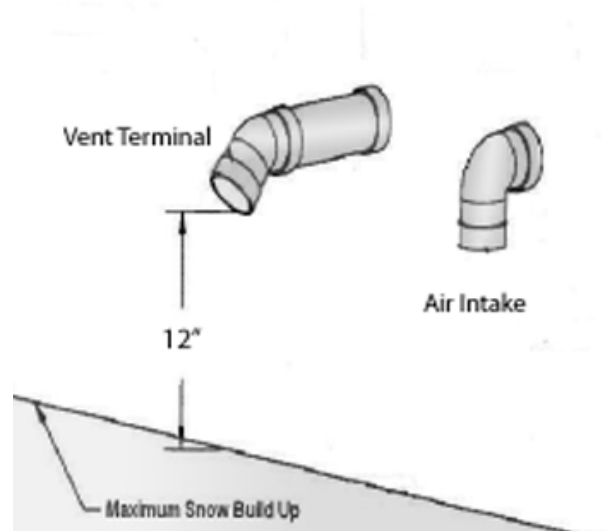

It is good practice to give a quick inspection of your furnace each time you inspect or clean the air filter.

Things to check:

- Check the furnace for obvious signs of deterioration.
- Check the venting and combustion air piping to ensure that it is still fastened to the furnace. It should not sag, and should have a ¼" to the foot slope upwards to the outside wall or termination.
- There should be no water marks on the floor under the venting. Water marks may indicate a leaking pipe joint.
- All ductwork should be secured to the furnace, and all ductwork should be solidly supported throughout the heating system.
- Water should flow easily through the condensate drain line. Excess debris in the drain line may indicate a problem which should be referred to your service contractor.
- The gas burner should be observed from time to time during the heating season to ensure that the flames are clean and blue. A bit of orange color in the flame is not likely to be a problem and is probably dust particles burning. If you observe lazy yellow flames, call your heating or service contractor immediately. The yellow flames inevitably lead to soot-ups.

**Furnace Appearance**

The furnace exterior finish is a durable automotive like coating. It may be washed with mild soap if necessary. Galvanized metal surfaces require no maintenance. It is advisable to keep dust buildup on warm surfaces to a minimum, since dust, in some cases, can be a combustible. Dust build-up in the circulating fan can impair blower performance; therefore, reduce efficiency. The recovery coil is located immediately above the blower assembly. Over time, it may become coated with dust.

To clean the recovery coil:

1. Disconnect electrical power to the furnace.
2. Remove the blower access door
3. Remove the screws fastening the blower assembly to the blower division panel.
4. Unplug harness from blower division, junction box and remove thermostat wires.

**CAUTION**



Label all wires prior to disconnection when servicing controls. Wiring errors can cause improper and dangerous operation.

Always verify operation after servicing.

5. Pull the blower assembly out.
6. Once the blower assembly has been removed, the coils may be vacuumed with the soft brush attachment. (Figure 4)

**Figure 4 - Recovery Coil Access**

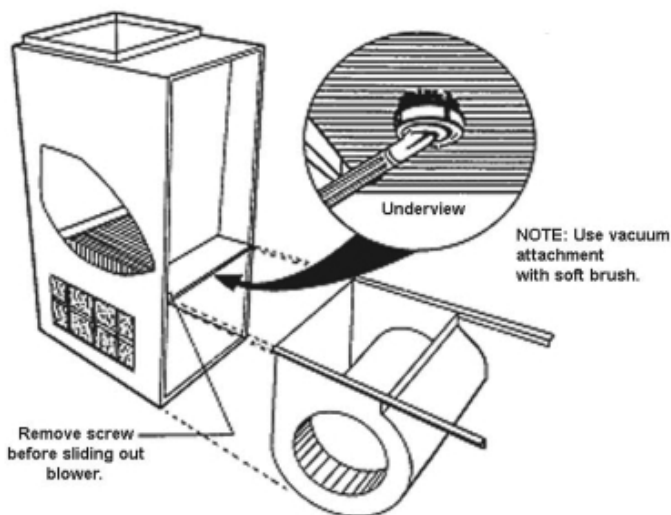

**NOTICE**

Be careful not to bend the fins when cleaning. You may wish to leave this maintenance procedure to your service technician.

7. Match up the blower rails with the hangers on the underside of the blower division panel, then slide the blower assembly back into position.
8. Replace the screws fastening the blower assembly to the blower division panel.
9. Secure harnesses to blower division and junction box. Connect thermostat wiring to the control board.
10. Replace the blower access door.
11. Restore electrical power to the furnace.

Routine cleaning the interior of the recovery coil should not be necessary. If evidence develops indicating that a cleaning is necessary, it should be done by a trained and qualified service technician. Evidence may include large amounts of dirt or debris building up in the condensate drain line.

The burner area should be inspected and cleaned periodically. Be careful when cleaning around the burner area. The hot surface igniter is fragile and will break easily. Do not touch the hot surface igniter or flame rod.

**WARNING**



NEVER ATTEMPT TO CLEAN THE BURNER AREA WHILE THE BURNERS ARE OPERATING. DOING SO MAY RESULT IN EXPLOSION OR FIRE RESULTING IN SEVERE PERSONAL INJURY OR DEATH.

ALWAYS DISCONNECT THE ELECTRICAL SUPPLY TO THE FURNACE BEFORE REMOVING THE BURNER COMPARTMENT ACCESS DOOR.

**CAUTION**



The furnace gas train is designed to operate as a sealed unit. Be sure that the burner compartment access door is properly in place before attempting to restart the furnace.



The furnace achieves its high efficiency in three general areas. First, there is no wasteful standing pilot. The furnace consumes no gas in between cycles. Secondly, the furnace is designed to allow very small amounts of excess air in the combustion process. Older furnaces had heat exchangers which were commonly 40% larger than necessary for complete combustion. While this prevented the creation of carbon monoxide, the heated excess air was expelled up the chimney where it could not benefit the interior of the home. Special safety controls now prevent the formation of carbon monoxide.

The third general area is the recovery of the latent heat contained in the flue gas, which is comprised of water vapor and carbon dioxide. By condensing the flue gas in the furnace recovery coil, heat that would otherwise be wasted to the outdoors, is captured and redirected into the duct system where it contributes to home comfort. Each pound of condensation formed releases approximately 970 BTUs. Your furnace may condense up to ½ gallon (5 pounds) of water per hour if running continuously.

The condensation must be properly disposed into a sump or drainage system. The condensate lines must remain clear and free flowing. Do not allow plastic drain lines to become pinched or kinked. A blocked drain line can cause the furnace to operate erratically, or not at all.

**NOTICE**

Your furnace should be cleaned and inspected annually by a trained and qualified service technician. Your service technician has the knowledge and test equipment to determine the condition of your furnace.

**95V Sequence of Operation**

1. Room temperature drops causing the room thermostat call for first stage heat by connecting “W1” to “R”. The control verifies the limit switch is closed and both the low and high pressure switches are open. The control energizes the induce draft motor on high speed and waits for the low pressure switch to close. The inducer remains on high speed and begins a 15 second pre-purge period. The high pressure switch is ignored. If the low pressure switch does not close within 60 seconds, the control will flash “2” on the Status LED, and de-energize the inducer for 60 minutes.
2. When the 15 second pre-purge time has elapsed, the control energizes the \*HSI output for a 5 second warm-up period (10 seconds on retries). The control energizes the low main gas valve. 4 seconds after the gas is energized, the control de-energized the \*HSI output and leaves the gas energized another 1 second for flame proving. If flame is present at the end of the trial for ignition time, the control leaves the gas valve energized, inducer on high speed, and begins heat blower on delay. The control always ignites on high inducer/low gas and ignores second stage call for heat until low heat is established for 15 seconds. (\*HSI= Hot Surface Ignition)
3. Blower on delay time begins when the gas 5 - HOMEOWNER’S REFERENCE valve is energized. The control provides the ECM (Electronically Commutated Motor) low heat speed signal when flame is proven, and starts a 30 second soft start (slowly ramp up) blower delay before full capacity blower level.
4. When there is a demand for 2nd stage heat from Thermostat W2 or automatic staging , the control changes the inducer from low to high speed. When high pressure switch closes, the control changes indoor blower speed from Low heat to High heat and energizes high gas output. If the High pressure switch is open the Green LED will flash. If the High pressure switch is closed the Green LED will be on. High gas valve drops out while high pressure switch is open because it is directly in series with the high pressure switch.
5. When the thermostat W2 call ends and W1 remains (two stage thermostat), the control de-energizes the high gas output and immediately changes inducer speed from high to low. With the thermostat heating contacts open (single stage thermostat), the flames extinguish immediately and the induced blower stops after a 5 second post purge time.
6. Blower off delay is handled by the ECM (Electronically Commutated Motor). The control de-energizes the ECM heat signal when the gas valve de-energizes, and starts a programmed soft stop (slowly ramp down) delay period.

### Variations

If your system includes air conditioning, your thermostat (supplied by the installer) will likely have two switches. The first switch is the system switch. The switch settings usually include HEAT, COOL, and OFF. Some thermostats have system switches which include HEAT, COOL, AUTO, and OFF. The system switch must be in the HEAT or AUTO position for the furnace to run.

The second switch is the fan switch. It usually has settings of ON and AUTO. The fan switch may be in either position when using the furnace. If the fan switch is set set to ON, the main blower will run continuously.

HOMEOWNER'S REFERENCE TABLE	
Model Number	
Serial Number	
Date Installed	
Contractor	
Contact	
Address	
Postal Code/Zip Code	
<i>If different from Installation Contractor:</i>	
Service Technician	
Telephone Number	
After Hours Number	
Fuel Supplier:	
Gas Supplier	
Contact	
Telephone Number	
After Hours Number	

**G95V**  
NATURAL AND PROPANE GAS TWO  
STAGE HIGH EFFICIENCY (CONDENSING)  
WARM AIR FURNACE



**ECR International**  
2201 Dwyer Avenue •  
Utica • New York • 13504 • USA  
[www.ecrinternational.com](http://www.ecrinternational.com)