

freewatt®



Hydronic freewatt Plus System, Model HDJ

POWERED by **HONDA™**

INSTALLATION, OPERATION & MAINTENANCE MANUAL



Information and specifications in the manual were in effect at time of printing of this manual. ECR International reserves the right to discontinue, change specifications or system design at any time without notice and without incurring any obligation, whatsoever.

An ISO 9001-2008 Certified Company
ECR International, Inc.
2201 Dwyer Ave.
Utica, NY 13501



P/N # 240008214, Rev. C [01/2011]

Check our website frequently for updates: www.freewatt.com www.ecrinternational.com

TABLE OF CONTENTS

1 - Safety Information.....	3
2 - Introduction.....	4
3 - Components, Controls and Accessories	12
4 - APC Universal Transfer Switch	14
5 - Compatible Room Thermostats	17
6 - freewatt Transfer Switch Model FTS-1.8	18
7 - Before installing the system.....	19
8 - Placing the system.....	22
9 - Exhaust Gas Leak Sensor	29
10 - Combustion Air and Vent Pipe.....	31
11 - Gas Supply Piping	33
12 - Electrical Wiring & Connections	34
13 - Commissioning and Startup.....	40
14 - Maintenance and Cleaning.....	41
15 - Detailed Sequence of Operation	43
16 - Troubleshooting.....	47
17 - Piping and Wiring Schematics	53

Safety Symbols

Manual contains important safety information. Read all **freewatt PLUS** System manuals for safety information and warnings.

DANGER
Indicates a hazardous situation which, if not avoided, WILL result in death or serious injury

WARNING
Indicates a hazardous situation which, if not avoided, could result in death or serious injury.

CAUTION
Indicates a hazardous situation which, if not avoided, could result in minor or moderate injury.

NOTICE
Used to address practices not related to personal injury.



Energy Star partner, ECR International has determined the boiler included as part of **freewatt PLUS** System meets Energy Star guidelines for energy efficiency.



Boiler and HI Module assembly design certified in US and Canada by Canadian Standards Association.



Honda MCHP Intertek-ETL Listed, "Utility Interactive, Cogeneration, Stationary Engine-Generator Assembly, Control # 3163904 (US)."



1 - SAFETY INFORMATION

WARNING

Fire, explosion, asphyxiation and electrical shock hazard. Improper installation could result in death or serious injury. Read this manual and understand all requirements before beginning installation.

WARNING

Do not install this system in mobile home! Boiler is not approved for installation in mobile home. Doing so could cause fire, personal injury or loss of life.

Instructions intended as aid to qualified, service personnel for proper installation, adjustment and operation of this system. Read instructions before attempting installation or operation. Failure to follow instructions could cause malfunction of system and result in death, serious bodily injury. Consult qualified installer, service agency or gas supplier for assistance or additional information.

WARNING

Do not store or use gasoline or other flammable vapors and liquids, or other combustible materials in vicinity of this or any other appliance.

Natural gas and propane are normally odorized by fuel supplier. Odorant may not be perceivable. Installation of UL and CUL recognized fuel gas detectors installed in accordance with manufacturer's instructions is recommended as additional safety.

Exhaust gases from boiler contain chemicals which may include carbon monoxide (CO). Carbon monoxide is odorless, tasteless, clear colorless gas, which is highly toxic. Even low concentrations are suspected of causing birth defects and other reproductive harm.

NOTICE

UL and ULC recognized CO detectors are required for all buildings equipped with ECR freewatt PLUS System. All CO detectors should be installed in accordance with manufacturer's instructions and applicable local building codes.

NOTICE

Installation Requirements Specific To The State Of Massachusetts, boiler installation must conform to Commonwealth of Massachusetts code 248 CMR which includes but is not limited to: Installation by licensed plumber or gas fitter.

1.1 Safety Information

- Check all applicable state, local building codes and utility company requirements before installation. Installation shall conform to these requirements in their entirety. In absence of these codes, use NFPA, National Gas and National Electric installation codes and authority having jurisdiction.
- Use only with gas approved for system components. Refer to boiler and MCHP unit rating plates.
- Provide adequate combustion and ventilation air to system space as specified in Section 10, "Combustion Air and Vent Pipe."
- Combustion products shall be discharged outdoors. Connect system components (boiler and MCHP unit) to approved vent system only, specified in Section 10, "Combustion Air and Vent Pipe'.
- Allow system to cool before servicing.
- Shut off electricity and gas supply connected to system before servicing.
- Never test for gas leaks with open flame. Use commercially available soap solution specifically made for detection of leaks to check all connections. See Section 11, 'Gas Supply Piping'.
- Verify natural gas input rate is correct. Over firing may result in early failure of the boiler's components. Under firing may result in too much air for combustion process causing poor or loss of combustion.
- Install boiler to operate within its intended temperature range. See boiler 'Installation Operation & Maintenance' manual.
- Follow regular service and maintenance schedule for efficient and safe operation.
- Keep system area clean of debris and free from combustible and flammable materials.
- System is not intended for temporary heating of buildings under construction.
- System is not do-it-yourself project. Install and service by qualified professionals only.

2- INTRODUCTION

2.1 Hydronic **freewatt PLUS** system is gas-fired micro-combined heat and power (micro-CHP) system suitable for residential and light commercial space and water heating applications up to 200,000 Btu/hr.

- **freewatt PLUS** System consists of these main components:
 - high efficiency (condensing) boiler
 - control module
 - hydronic hybrid integration (HI) module
 - HONDA MCHP unit
 - **freewatt** transfer switch
 - electrical load distribution and management panel
 - zone control relays
 - heat rejection system
- **freewatt** high efficiency boiler Model FW95M certified as Category IV direct vent central heating boiler with combustion air supplied directly from outdoors through special air intake system. Combustion products of **freewatt** Boiler are exhausted to outdoors through direct vent system.
- Hydronic hybrid integration (HI) module and control module integrate **freewatt** Boiler and HONDA MCHP unit into hydronic heating circuit of building.
- HONDA MCHP unit, Model MCHP1.2 D & DP, is manufactured by HONDA Corporation for use with **freewatt PLUS** System.
 - Produces electrical power while also generating heat in response to building's normal thermostatic heat demand. The
 - Produces 240VAC power delivered to main circuit panel through 240VAC dedicated circuit.
 - Certified under UL 2200 - Stationary Generators and UL 1741 - Inverters, Converters, Controllers and Interconnection System Equipment for Use With Distributed Energy Resources.
 - HONDA MCHP unit utilizes indoor air for combustion and vents combustion products to outdoors with PVC pipe. Honda MCHP unit is non-direct vent appliance.

For additional details on system components refer to section 3.

2.2 Application Notes

- Maximum design water temperature of 160°F. Heat emitters sized for heat output using maximum design water temperature of 160°F. Heat loss calculations based on approved industry methods and outdoor temperature corresponding to design water temperature appropriate for local area's weather.
- Hydronic **freewatt PLUS** System may be applied to normal variety of heating loads served by conventional, multi-zone hydronic heating systems.
 - base-board radiation,
 - radiant floor heating,
 - domestic hot water via indirect storage tank,
 - powered convective heaters,
 - hydro-air handlers*

NOTE: *Application limited to specific air handler models.

- Hydronic **freewatt PLUS** Systems use circulators or valves for individual zone temperature control. Configuration of hydronic distribution system must be in form shown in this manual with respect to overall arrangement of **freewatt PLUS** Boiler and MCHP unit with respect to zone loads.
- See specific piping schematics provided for systems zoned with circulators and valves and for systems using air handlers.
- **freewatt** Control Module is common to all applications of hydronic **freewatt PLUS** System. Different ECR zone pump/valve relay controls required for use with pump and valve-zoned systems and hydro-air systems.
 - Appropriate pump/valve relay control from ECR family of zone controls must be used as supplied with **freewatt PLUS** System.
 - See specific electrical wiring diagrams provide for circulator zoned systems, valve zone systems, and systems with air handlers.
- Do not use anti-freeze solution in **freewatt PLUS** System hydronic flow loop. Use only good quality water. Install heat exchanger to isolate anti-freeze solution from main hydronic system, if particular zone requires anti-freeze protection.
- Priority domestic hot water heating is available and must be properly selected in setup of Control Module and ECR zone controls.
 - Indirect water heater aquastat setting must be between 120 to 125°F.
 - Mixing valve must be used on domestic water supply outlet of any indirect water heating tank applied with **freewatt PLUS**. Do not use set back.

2- INTRODUCTION

WARNING

Burn and scald hazard. Failure to install mixing valve will result in hot water scalding hazard. Install mixing valve per manufacturer instructions.

- Hydronic system is supplied with **freewatt** communicating thermostat. Utilize thermostat on single “Smart Zone” only. Select “Smart Zone” as zone with largest heating demand (not domestic hot water zone) typically the largest space heating zone on first floor of two story home. **freewatt PLUS** System will produce best electric power generation benefit if Smart Zone represents at least 25% of total home heating load. Consider combining zones to achieve desired heat load for Smart Zone if there is no single large zone in existing distribution system, but many small zones.
 - freewatt** communicating thermostat is directly wired to **freewatt** Control Module circuit board. Additional five zones, with compatible conventional heating thermostats (new or existing) may be connected directly to **freewatt** Control Module circuit board. If more than compatible six zones (including priority domestic hot water and Smart Zone) are needed **freewatt PLUS** System can be expanded to include additional heating zones. Additional ECR zone controls may be required.
 - Hydronic **freewatt PLUS** System installation may be phased. Install **freewatt PLUS** Boiler and Control Module in required piping configuration as shown in **Section 17**, leaving installation, commissioning, and operation of MCHP to later date (cap off piping connections to MCHP), if need to supply heat to building quickly as possible. **freewatt PLUS** boiler will provide sufficient heating capacity to meet normal loads if MCHP unit is not available for operation.
 - MCHP unit will provide significant portion of annual heating energy needed in home, MCHP unit alone cannot be expected to meet all desired comfort and/or freeze protection needs. Maintaining operation status of **freewatt** Boiler as part of **freewatt PLUS** System is essential to meeting all comfort and/or freeze protection needs.
 - “CHP MODE” switch OFF position conveniently separates and maintains boiler heating function while disabling operation of MCHP unit and generation of electric power. This is Bypass Mode of operation.
 - Full heating operation of hydronic **freewatt PLUS** System is not dependent on maintaining working connection to Internet. Lack of internet connection will prevent remote communication with system by homeowner or service provider.
- Installation of UL and ULC recognized CO detectors with audible alarms (not supplied with system) are required part of **freewatt PLUS** installation. **freewatt PLUS** Exhaust Gas Detection System included part of **freewatt PLUS** System does not provide audible alarm for protection of building inhabitants from potentially dangerous high levels of carbon monoxide. Install both Exhaust Gas Detection System and separate, independent UL recognized CO Detectors.
 - Installation of two different outdoor temperature sensors is required for proper operation of hydronic **freewatt PLUS** System, both are supplied. One (Honeywell) connects directly to boiler and other (Tekmar) to **freewatt** Control Module.
 - hydronic **freewatt PLUS** System will generate heat & electric power during power outage if installed and commissioned per Installation, Operation, and Maintenance Manual. Heating system must be connected to APC UTS.
 - Installation, setup, commissioning and maintenance of **freewatt PLUS** System requires use of **freewatt PLUS** MINT software tool loaded on laptop computer running Windows XP or Vista with working serial connection.
 - Call **freewatt PLUS** Technical Support Line for **freewatt PLUS** System installations above 3,300 feet and for additional information.
 - Heat rejection kit (sold separately) required for installation.
 - Water cooled heat rejection kit used when there is uninterruptable supply of water during power outage. Kit ties into main water supply line and discharges water to appropriate drain.
 - Air cooled heat rejection kit used when there is not uninterruptable supply of water during outage (houses with well pumps). Air cooled heat rejection system is vertically arranged side discharge fan-coil unit with closed coolant loop designed for outdoor installation.
 - Zone Valves with their own 24 VAC power supply may be used on zones 3-6. Refer to Electrical Wiring and Connections section for detailed information on use of steering relays in **freewatt** control module.

2- INTRODUCTION

2.3 Save These Instructions

Read this manual carefully and keep for future reference by service technician. Manual is considered permanent part of your Hydronic **freewatt PLUS** System and should remain with system.

Manufacturer is not responsible for any field installation changes made to system installation that are not described or acknowledged in this manual.

Product must be installed by licensed plumber or gas fitter when installed within Commonwealth of Massachusetts.

Appliance has been equipped for residential installations. If used for commercial applications, all code requirements must be adhered to for installation. May require additional controls or system components.

2.4 Read All Documents

- Hydronic **freewatt PLUS** (Model HDJ) User's Information Manual.
- **freewatt** FW95M-200 Boiler Installation, Installation, Operation and Maintenance Manual, Parameter Guide, Control Manual & Troubleshooting Guide.
- HONDA MCHP, Model1.2D and MCHP1.2DP, Type UCFJ, Installation Manual and Owner's Manual.
- HAI Thermostat Installation Instructions and Owner's Manual
- Applicable ECR Zone Control Manual
- **freewatt** Indirect Water Heater Set-up, Operating & Maintenance Instruction Manual
- **freewatt** Transfer Switch Installation, Operation and Maintenance Manual.
- APC Universal Transfer Switch Site Preparation and Installation Guide.
- Hydronic **freewatt** (model HDJ) Control Module Installation, Operation and Maintenance Manual.

2- INTRODUCTION

Figure 2-1 - freewatt PLUS System Components (Zoned with Circulators)

freewatt® PLUS System Components

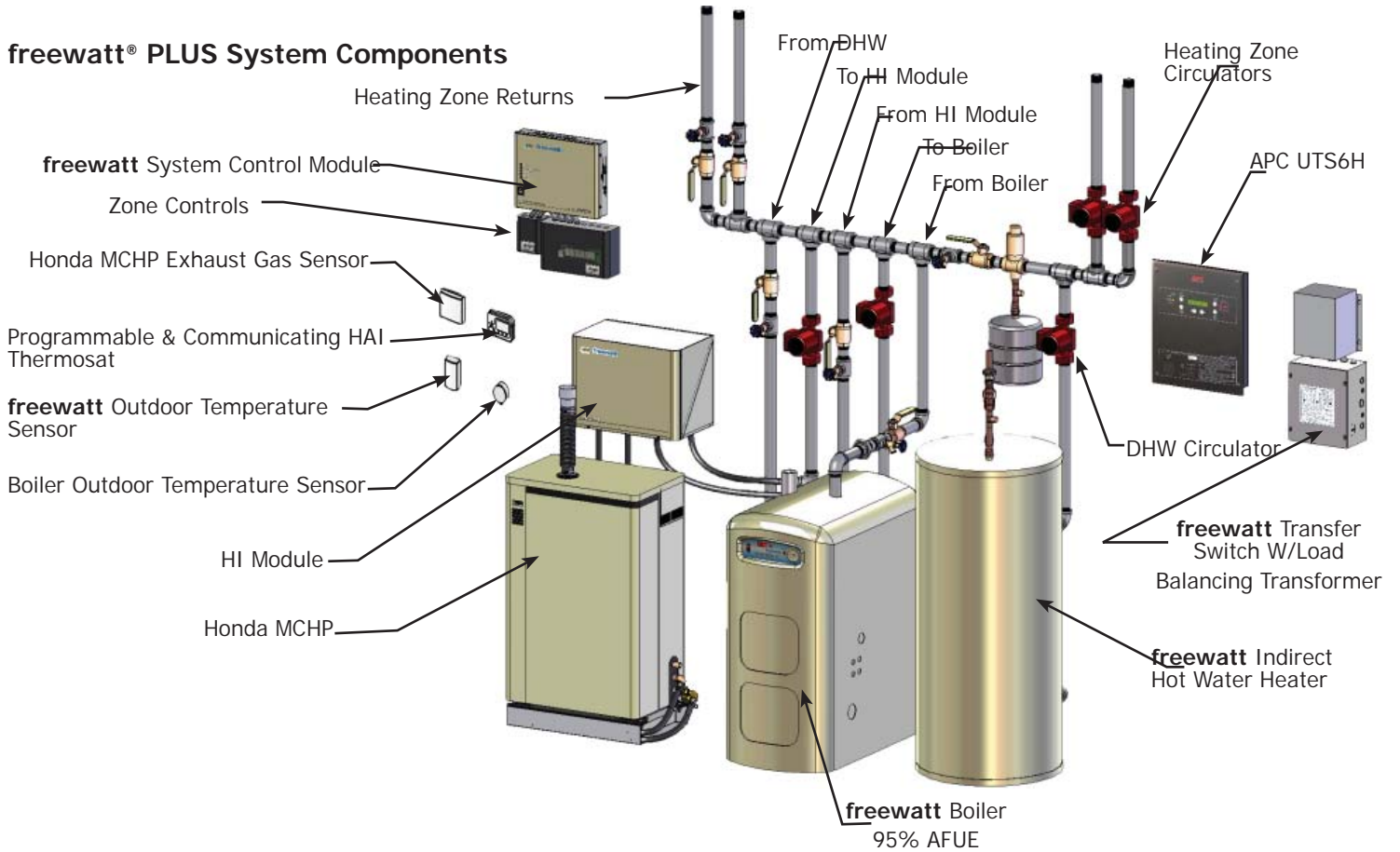
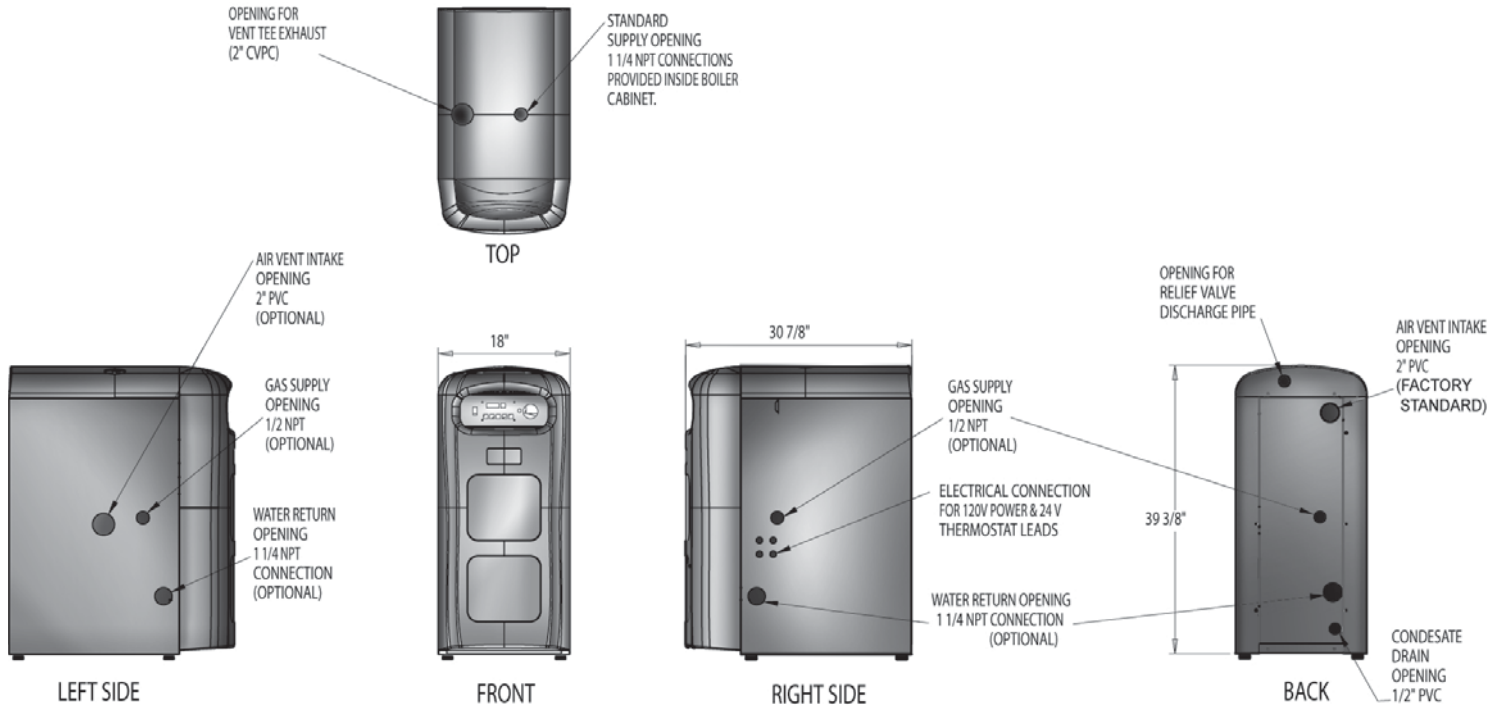

Figure 2 -2 freewatt PLUS Boiler



2- INTRODUCTION

Table 2-1 System Rating and Sizing						
Unit		Input (MBH)	Heating Capacity (MBH)	Overall Efficiency (%)	Nominal Power (kWe)	Weight (lbs)
Honda MCHP Unit (0 - 3,300')	MCHP Mode	18.4	12.3	12.3	1.2	180
	Backup Mode	18.5 - 26	12 - 17	12 - 17	0 - 1.8	180
	Boost Mode	26	17	17	1.8	180
Boiler						
Boiler Module (0 - 2,000')		80-200	76-190	95%	-	284

Ratings are for sea level applications.

Boiler: Consult boiler Installation, Operation and Maintenance Manual for high altitude conversion and derating instructions.

Honda MCHP: Consult with ECR International Technical Support for high altitude conversion and derating instructions
Boiler manual has I=B=R Net Rating (MBH) data for system design.

Proper application of Hydronic **freewatt PLUS** System requires assessment of heat loss and applied building needs. Relatively lower heat output of MCHP unit, priority heating device, and automatic modulation of firing rate of condensing boiler allows Hydronic **freewatt PLUS** System to be applied to wide range of loads without efficiency penalty. System performance depends significantly on sizing of heat distribution system relative to actual space heating demands. Under-radiated distribution systems that require high system water temperatures (above 180°F during design (coldest) day outdoor temperature conditions) will significantly compromise electric generation performance of **freewatt PLUS** System. Recommend hydronic heating system be designed for 160°F or lower water temperature to produce greatest annual electrical power generation and highest energy efficiency. 160°F design water temperature may require installation of new radiation or re-configuration of existing radiation to acceptably heat zones.

Hydronic **freewatt PLUS** System operates with two levels of heat: HONDA MCHP's thermal output delivering low heat and boiler delivering high heat. **freewatt PLUS** uses proprietary heating algorithm to ensure long MCHP operating hours will maximize system's electrical power production. Boiler will fire to provide heat if additional heat is needed or anticipated.

Boiler will automatically modulate in range of 80,000 to 200,000 BTU/hour, and MCHP unit will continue to run to provide needed level of heat supply in high heat mode. Hydronic **freewatt PLUS** System operates with automatic and programmable outdoor temperature reset of hydronic system water temperature to provide uniform heating.

2- INTRODUCTION

Figure 2-3 MCHP & Hydronic Hybrid Integration Module

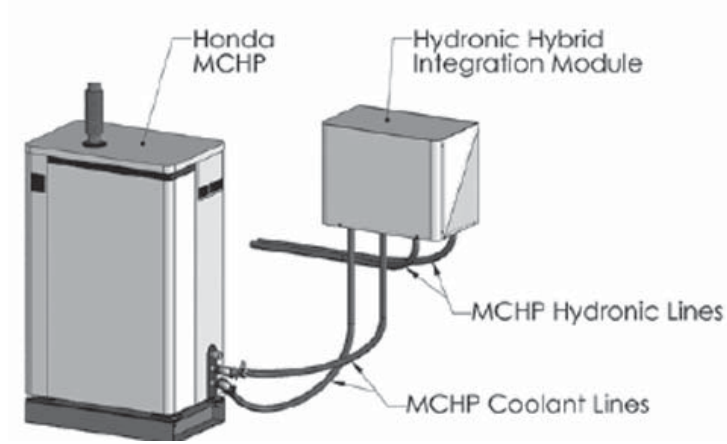

Figure 2-4b Hydronic Hybrid Integration Module

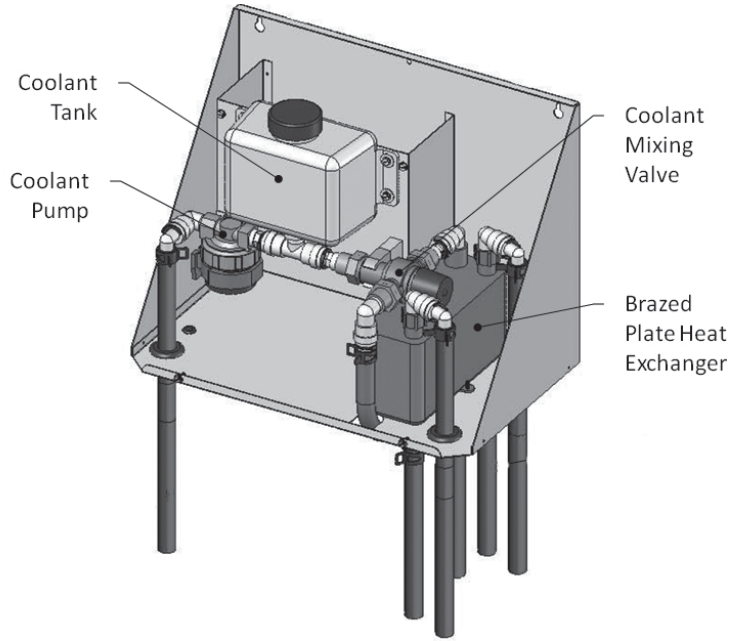

Figure 2-4a Hydronic Hybrid Integration Module

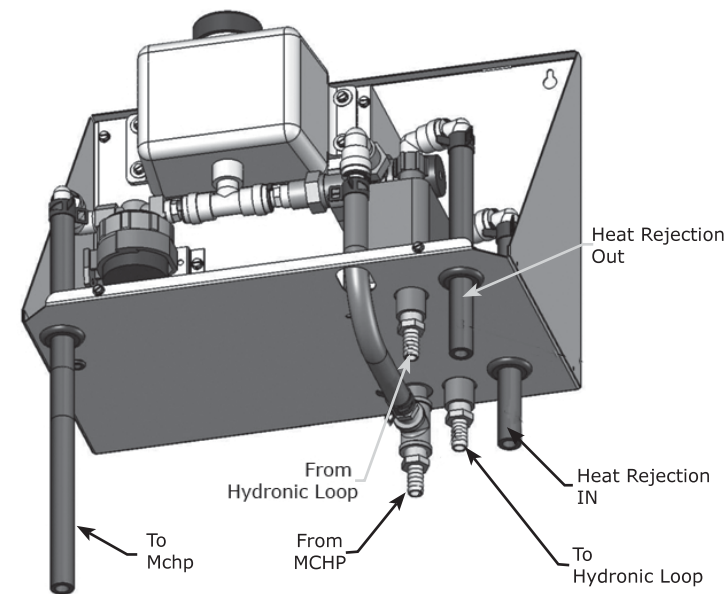
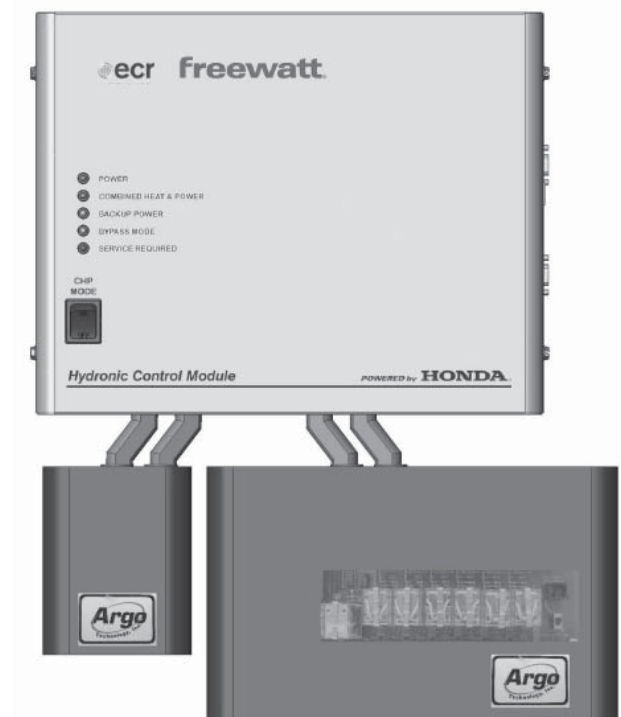

Figure 2-5 Typical freewatt PLUS Control Module Configuration



2- INTRODUCTION

Figure 2-6 freewatt PLUS Control Module Details

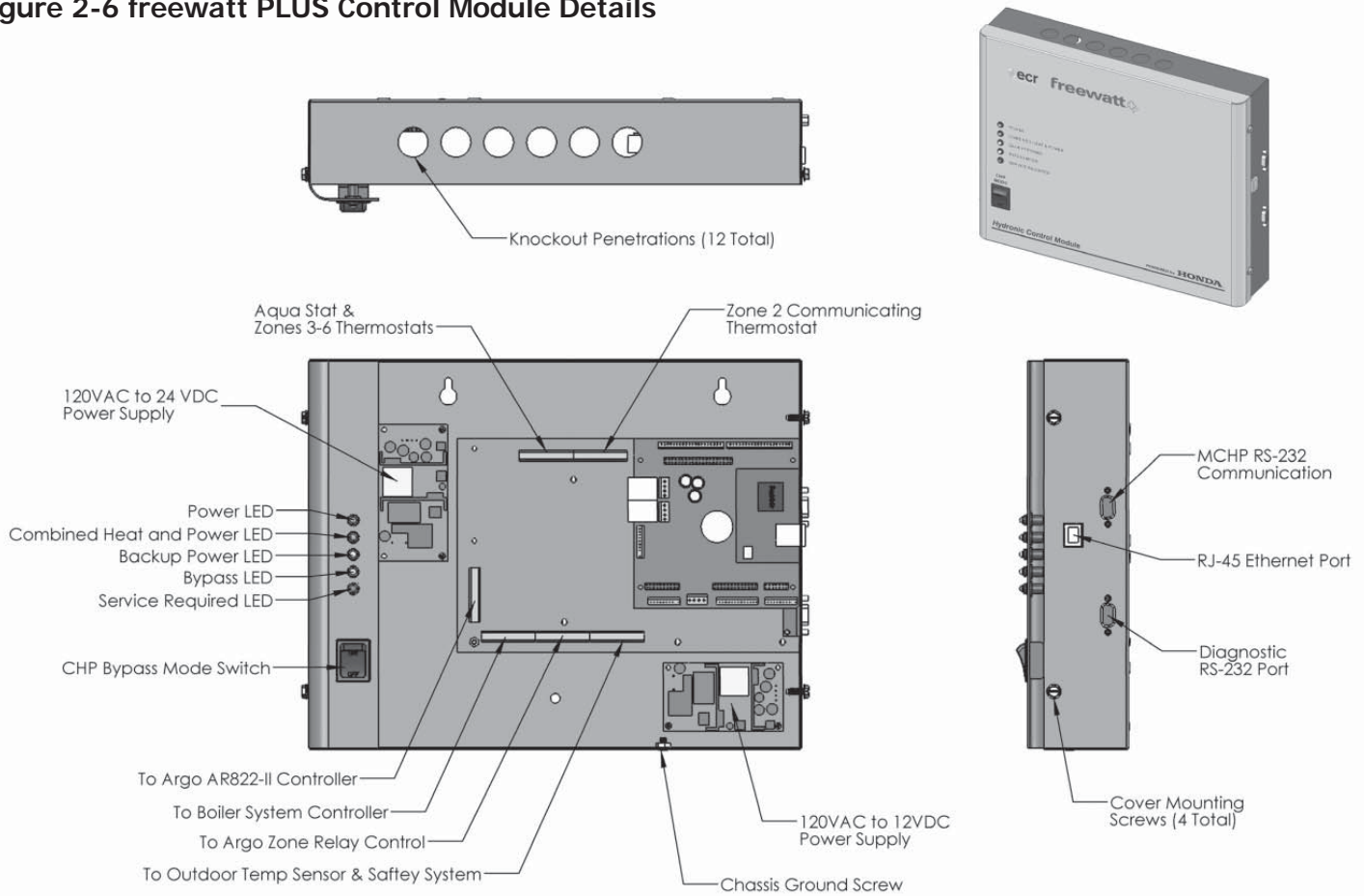
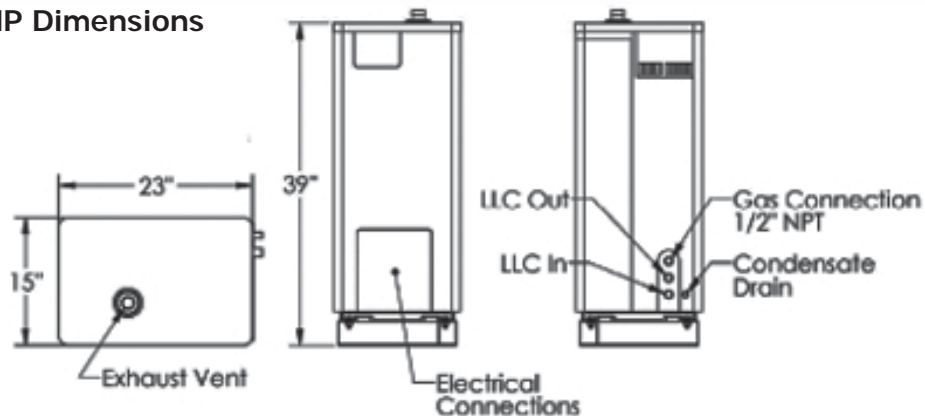

Figure 2-7 MCHP Dimensions



System Clearances to Combustibles		
Dimensions	Boiler	Honda MCHP
Top	1" (8" for service)	14"
Sides	1" (24" for service)	0.4" (12" for service)
Base	See Note 1	See Note 2
Front	0" (24" for service)	0.4" (20" for service)
Rear	6"	0.4" (2" for service)
Intake/Vent Piping	0"	0"
Near Boiler HW Piping	1"	0"

NOTE: 1. Combustible floor approved, but not carpet.
 2. MCHP attached to base anchored to concrete floor.

2- INTRODUCTION

Figure 2-8 MCHP Electrical Connection Details

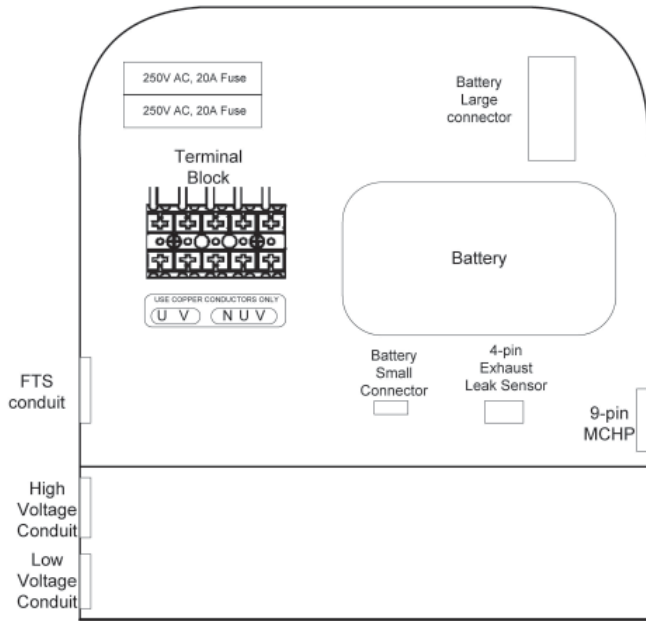
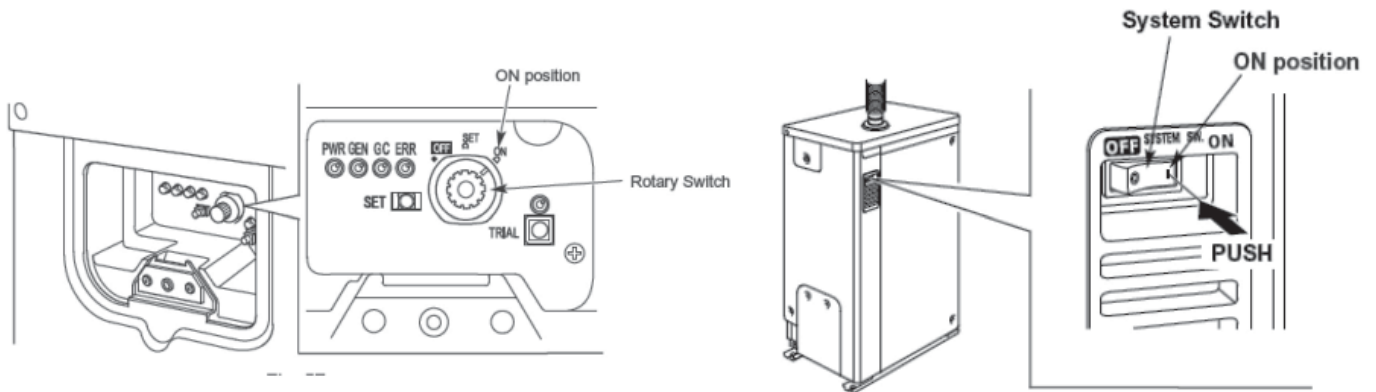

Figure 2-9 MCHP Front Interface Details



3 - COMPONENTS, CONTROLS AND ACCESSORIES

Section provides brief description of components, controls, and accessories of hydronic **freewatt PLUS** System.

3.1 Boiler

Refer to separate **freewatt** boiler documentation for detailed information on the **freewatt** boiler.

3.2 freewatt Control Module

- **freewatt** control module monitors and controls operation of Hydronic **freewatt PLUS** System. Sensing inside and outside temperature as well as other system temperatures and settings, proprietary heating algorithm controls operation of Honda MCHP optimizing power production and low level heat delivery.
- **freewatt** control module includes relay/interconnect board, DC power supply, and advanced single-board computer board incorporating powerful microprocessor, RS-232/RS-485 serial ports, and 10/100 Base-T Ethernet port.

3.3 freewatt PLUS Hydronic Hybrid Integration (HI) Module

- **freewatt PLUS** Hydronic HI Module location is where heat in MCHP coolant is transferred into hydronic water.
- **freewatt PLUS** Hydronic HI module consists of brazed plate heat exchanger, mixing valve, coolant reservoir and coolant pump.
- Hydronic water is pumped through secondary circuit, MCHP coolant is pumped through primary circuit.
- Mixing valve is field adjusted to deliver minimum 152°F coolant to pump, which returns coolant to Honda MCHP unit.
- Coolant reservoir holds spare coolant and is instrumental in proper commissioning of system.
- Hydronic HI Module designed to mount on adjacent wall or on side of boiler. Module's brazed plate heat exchanger has two ¾" NPT hydronic water connections and two ¾" NPT coolant loop connections connected to HI module
- Hydronic water circulator for HI module is mounted external to HI module as part of hydronic system piping.
- **freewatt** control module operates both HI module coolant pump and hydronic circulator supplying hydronic water flow to HI module. Coolant pump operates on 24VDC supplied directly by **freewatt** control module. Associated 120VDC hydronic circulator is powered through ECR AR822-II relay control.

3.4 HONDA MCHP Unit

- Honda MCHP Unit is custom-engineered micro-combined heat and power module integrated into Hydronic **freewatt PLUS** System. MCHP unit designed to start and stop by means of digital signal from control module when control module senses there is heat demand in dwelling.
- MCHP unit is ETL certified for grid interconnection if your utility allows, unit can deliver electrical power back into electric grid. Unit provides system operating data and diagnostic data to control module.

3.5 Smart Zone Communicating Thermostat

- Smart zone communicating HAI thermostat communicates directly with control module. Allows **freewatt** control module to download thermostat settings and maximize system's electrical power generation, providing higher level of comfort to dwelling.
- Zone which thermostat is applied is referred to as "Smart Zone". Supplied communicating thermostat must be used on one space heating zone of hydronic system. **freewatt PLUS** System will not work with any other thermostat installed in "Smart Zone". Compatible conventional thermostats, may be used in other zones.

3.6 Outdoor Temperature Sensor

- Hydronic **freewatt PLUS** System uses two outdoor temperature sensors to anticipate heat demand within dwelling by tracking outdoor temperature. Control module will determine optimum temperature to activate Honda MCHP unit and provide thermal comfort, maximizing generation of electrical power as outdoor temperature falls.
- Honeywell temperature sensor is connected directly to **freewatt PLUS** Boiler and Tekmar temperature sensor is connected directly to **freewatt** Control Module.
- Both sensors are required for proper operation. Route in separate cables at least on foot apart to ensure signal quality.

3.7 Internet Connection

Connecting control module to high-speed internet service allows **freewatt PLUS** service provider to monitor system's operating characteristics. **freewatt** control module will notify service provider of abnormality, if system has operating characteristics outside normal operating range and remote monitoring system is enabled and active.

3 - COMPONENTS, CONTROLS AND ACCESSORIES

3.8 Website

freewatt control module web site address is assigned to system at time of installation allowing homeowner and service provider to monitor or control system's operation.

3.9 External Condensate Pump

- Float activated condensate pump with integral sump is required for installation where there is no floor drain or other appropriate drainage receptacle available to receive condensate from system (boiler and MCHP unit).
- Condensate pump can be piped to remote point to sanitary sewer system (Please follow all state or local regulations regarding disposal of condensate). Install system so proper pitch can be placed on piping to deliver condensate safely to external condensate sump.

3.10 Exhaust Gas Leak Sensor

- Exhaust Gas Leak Sensor (EGLS) monitors integrity of Honda MCHP unit combustion system and shuts down MCHP unit if certain potentially unsafe conditions are detected.
- Monitors carbon monoxide level in air space near MCHP unit.
- Exhaust Gas Leak Sensor is independent and separate from audible CO alarming system installed with **freewatt PLUS** System in compliance with best practices for all fuel-fired central heating equipment.
- Proper installation of the EGLS is required to commission Hydronic **freewatt PLUS** System.

3.11 Concentric Vent/Air Intake Termination (Optional)

- Optional concentric vent/air intake termination utilizes single opening for boiler through wall or roof of structure.
- MCHP unit requires use of exhaust vent.

3.12 Heat Rejection System

Heat rejection kit (sold separately) is required for backup mode operation during times when no space heating or water heating is required.

- A water cooled heat rejection system is available for installations where there is uninterrupted supply of water during power outage (city water). Kit ties into main water supply line and discharges water to appropriate drain. Drain must be suitable for 0.35 GPM at 180° F. Kit contains ball valve, pressure reducer, electronic ball valve, and flow reducer. Installer must supply piping to tie into main water line, and deliver water to appropriate drain.

- Installations without uninterrupted supply of water during power outage (most houses with well pumps) air cooled heat rejection system is available. Contains vertically arranged side discharge fan-coil unit installed outside, and is connected to HI Module through closed coolant loop. Dimensions of unit are 24" Length, 15" Width, and 36" Height.
- Air cooled heat rejection system installer must supply secure mounting pad or foundation, power wiring, low voltage wiring (18 AWG minimum), and closed Propylene Glycol coolant loop from HI Module to unit (3/4" piping, circulator, air separator, pressure relief valve, expansion tank, flow check, and purge valve). See FWHRJ Air cooled heat rejection system Installation, Operation, Maintenance manual for specific installation instructions.

3.13 Display/User Interface

Homeowner can scroll through control settings and change operating settings to customize **freewatt PLUS** System operation using PC.

3.14 Internet Connection & Commissioning

- **freewatt** System control module connects to customer's home network in same way any computer or other network appliance does connecting via Ethernet connection available on most routers. **freewatt PLUS** connection uses 10/100 Mbit/s wired Ethernet connection, wireless bridges may be used when wired connection isn't possible.
- **freewatt** control module is assigned static address outside of DHCP range available from router.
- IP address, netmask, gateway and DNS addresses are programmed into control module using **freewatt PLUS** service tool. Common configuration (with router at address 192.168.1.1) would have **freewatt** address set to 192.168.1.200, netmask set to 255.255.255.0, gateway set to 192.168.1.1 and DNS entries set to 208.67.222.222 and 208.67.220.220 (addresses for Open DNS).
- Router configured to allow incoming traffic for diagnostics and (if requested by customer) access to user web page. Routers refer to these settings as 'port forwarding', 'applications', or 'virtual servers'. Refer to router manufacturer's documentation.
- Remote diagnostics require port 4500 be directed to **freewatt** control module. Port for customer web pages is configurable - usually set to 8082 because many ISPs (Internet Service Provider) block use of standard port 80.
- Number of wireless bridge or gaming bridges have been tested to work with control module if wireless configuration is required. Configure using manufacturer's instructions.

4 -APC UNIVERSAL TRANSFER SWITCH CONFIGURATION

NOTICE

APC universal transfer switch is provided for use with **freewatt** Plus system and is not intended for emergency backup power applications. Manufacturer is not responsible for the use of this switch in any manner not outlined in this manual or APC UTS6H Installation Guide.

4.1 APC Universal Transfer Switch

- **freewatt PLUS** System incorporates APC Universal Transfer Switch as load panel in Back-Up Power Mode.
- UTS6H requires customized configuration in order to operate effectively with **freewatt PLUS** System. Following section will explain configuration process for this component.
- Set-up for APC Universal Transfer Switch (UTS6H) involves following System Configuration and Setup section in UTS's Installation Guide.
- Important notes about this product:

WARNING

Improper configuration may result in improper operation of **freewatt PLUS** System in Backup Power Mode. Failure to follow these instructions could cause malfunction of system and result in death, or serious bodily injury. Read and follow these instructions before attempting installation, commissioning or operation.

NOTICE

Use only outlet mounted AFCI and GFCI circuit interrupters with the UTS. Do not connect the UTS to circuits utilizing AFCI or GFCI circuit breakers in the main electrical panel.

Circuit 1

- Circuit 1 includes Load attached to Circuit-labeled "1" and convenience outlet on front of UTS6H, together must consume less than 15 amps when system is operating in Backup Mode. If not using Uninterruptable Power Supply (UPS), it is recommended to use circuit 1 to power **freewatt PLUS** System's low power condensate pump.
- Circuit 1 is only powered by MCHP when in Backup Power Mode. It will not be powered from UPS if UTS6H is equipped and configured to use UPS. It is recommended that UPS be plugged into front convenience outlet and therefore is powered by Circuit 1.

Circuit 5 & 6

- Although all UTS circuits do not need to be used, Circuits 5 & 6 must be connected to main circuit panel and must receive power for UTS to function. Circuits 5 & 6 must also be connected to circuits that are in opposite phases, so 240V is present across two circuits. Allows UTS6H to monitor Utility power supply.

4.2 Uninterruptible Power Supply (UPS)

- If using UPS to power "uninterruptable" loads, plug UPS power input cord into convenience outlet to charge UPS batteries when MCHP Backup Power is available. Note, UPS batteries will also be charged from convenience outlet when grid power is available.
- Follow UPS and UTS6H instructions for sizing UPS for loads configured to be powered by UPS in Backup Mode. Typically, low power circuits, such as computers or security systems, are configured for use with UPS.

4.3 Non-Delayable & Delayable Circuits

- Circuit assigned to **freewatt** boiler shown in examples on Circuit 3 must be configured as "Delayable-No" to ensure **freewatt PLUS** System always has power when in Backup Mode, otherwise system may not operate correctly.
- All other circuits must be configured as "Delayable-Yes" except in case of example where UPS is used and circuit source is configured as "UPS" or "Un-interruptable".

4.4 Hardwire Kit

- UTS6H is supplied with Hardwire Kit used to connect **freewatt PLUS** Transfer Switch to UTS6H. See Parts, Kits & Optional Accessories for kit part number. Hard-wire kit is installed in UTS6H and accepts cable delivering Honda generator's backup power output. Follow electrical schematics in this manual and instructions in Hard-wire Kit for installation.

NOTICE

Circuits 5 & 6 must be connected to circuits in opposite phases to ensure 240VAC is present across two circuits, to allow UTS6H to monitor utility power supply and sense power outage.

NOTICE

Mark all breakers in Electric Panel as moved to UTS6H for future reference.

4 - APC UNIVERSAL TRANSFER SWITCH CONFIGURATION

Table 4-1 Typical UTS6H Circuit Setup *without* UPS

Typical UTS Circuit Setup without UPS						
PARAMETER	CIRCUIT 1	CIRCUIT 2	CIRCUIT 3	CIRCUIT 4	CIRCUIT 5	CIRCUIT 6
Load Type	Other (condensate pump)	Sump pump	Boiler	Computer	Security System	Refrigerator
Source	GEN	GEN	GEN	GEN	GEN	GEN
Delayable	Yes	Yes (1)	No	Yes	Yes	Yes
Max time off (min)	30	1	30	5	60	30
Min time on (min)	30	2	30	5	60	15
Security Mode	Off	Off	Off	Off	Off	Off
Amp Rating(A)	15	15	15	15	15	15

Note (1)

Delayable - Yes: Setting is required for Warm Air **freewatt PLUS** System boiler to prevent **freewatt PLUS** System or sump pump from losing power when in Backup Mode. If sump pump and boiler may operate at same time (power outages during heating season and heavy rain events), possible solutions include:

- A. Battery-backed sump pump
- B. UPS and configure sump pump power source as "Either" UPS or Generator.

Table 4-2 Typical UTS6H System Setup *without* UPS

Typical UTS6H System Setup <i>without</i> UPS	
Bypass mode	No
Load shedding?	On
Voltage sensitivity	Medium
Time Management	On
Reset Energy Meter	No
System Test	No
Backup1 Source Type	Generator
GEN power rating	1700 (1)
GEN SRGE Overload Time	0 seconds
GEN Start Mode	manual
Backup2 Source Type	none
GEN power rating	1800
GEN SRGE Overload Time	0 seconds
Reset to default	no

NOTE:

(1) Available generator power is set to 1,700 watts to account for 100 watt power consumption of load balancing transformer.

4 - APC UNIVERSAL TRANSFER SWITCH CONFIGURATION

Table 4-3 Typical UTS6H Circuit Setup *with* UPS

Typical UTS Circuit Setup <i>with</i> UPS						
PARAMETER	CIRCUIT 1	CIRCUIT 2	CIRCUIT 3	CIRCUIT 4	CIRCUIT 5	CIRCUIT 6
Load Type	Other (condensate pump)	Sump pump	Boiler	Computer	Security System	Refrigerator
Source	GEN	EITHER	GEN	EITHER	EITHER	GEN
Delayable	Yes	Yes	No	Yes	Yes	Yes
Max time off (min)	30	1	30	5	60	30
Min time on (min)	30	2	30	5	60	15
Security Mode	Off	Off	Off	Off	Off	Off
Amp Rating(A)	15	15	15	15	15	15

Note: UPS power output cord shall be attached to "UPS" inlet port of the UTS6H.

Table 4-4 - Typical UTS6H System Setup *with* UPS

Typical UTS6H System Setup <i>with</i> UPS	
Bypass mode	No
Load shedding?	On
Voltage sensitivity	Medium
Time Management	On
Reset Energy Meter	No
System Test	No
Backup1 Source Type	Generator (1)
GEN power rating	1700 (2)
GEN SRGE Overload Time	0 seconds
GEN Start Mode	manual
Backup2 Source Type	UPS (3)
GEN power rating	2100 (4)
GEN SRGE Overload Time	0 seconds
Reset to default	no

Notes:

1. **Generator:** Corresponds to 240VAC GEN port on UTS6H.
2. **GEN Power Rating (Backup1):** Set to 1,700 watts to account for 100 watt power consumption of load balancing transformer.
3. **UPS:** Corresponds to UPS inlet port on UTS6H.
4. **GEN Power Rating (Backup2):** Corresponds to 1,700 watts of MCHP power **PLUS** UPS power rating (in this case 400 watts).

5 - COMPATIBLE ROOM THERMOSTATS

5.1 freewatt Hydronic Zone Thermostat

Requirements:

Select heat or heat/cool thermostat with following properties, except Zone-2. Zone 2 must use HAI Smart Zone Thermostat.

- Use isolated relay contacts to switch W call for heat signal. **freewatt** expects 24VAC "HOT" connected to thermostat's "R" terminal to pass directly thru thermostat's W relay to drive "W" signal back with minimal loss of signal voltage when calling for heat.
- Thermostat's W relay must present high-impedance (ie. no current flow) when open, not calling for heat.
- Thermostat must not add resistive elements to W signal path (resistors, voltage divider networks, MOSFET(s), transistors, etc.) when not calling for heat. Open circuit impedance of W signal path must be greater than 100,000 ohms, and preferably higher (ie 1 Megohms or more).

5.2 Known Problematic Thermostats:

- Honeywell T87N, T87K

5.3 Known Compatible thermostats:

- HAI Omnistat1, Onmistat2
- LUX 1500
- Braeburn Model 3000

5.4 Tests For Thermostat Compatibility:

- Resistance test:
 - Thermostat calling for heat, W relay closed: Thermostat relay impedance must be less than 40 ohms when measured across thermostat R and W terminals. Impedance greater than 40 ohms is unacceptable and will not work reliably with **freewatt PLUS** System.
 - Thermostat not calling for heat, W relay open: Thermostat relay impedance should be greater than 1 Megohm (1 million ohms).
- Voltage test:
 - AC voltage measured between 24V common terminal on circuit board J02 connector (labeled 24VAC - bottom of board) and circuit board J02 W1, W3 or W4 terminals (top of board) must be less than 1.5 Volts AC when no call for heat, attached to **freewatt PLUS** System and powered by 24 to 28 volts AC from **freewatt** Control Module. Thermostat not suitable for use with **freewatt PLUS** System if voltage is greater than 1.5 Volts AC.

- Voltage must be greater than 20 Volts AC, when thermostat calls for heat. Thermostat is not suitable for use with **freewatt PLUS** System if voltage is less than 20 Volts AC.

5.5 Communication Registers On RC-1000 Smart Zone Thermostat:

- Apply factory reset to restore communications on RC-1000-WH-ECR. Press ("click") on scroll wheel to start.
- Select "Setup".
- Select "Installation Settings".
- Notice warning for installers. Press "Continue".
- Select "Factory Reset" (last item in list).
- Press "Back" as required to return to normal operation. All settings, including setback programming have been cleared.

6 - freewatt TRANSFER SWITCH MODEL FTS-1.8

6.1 freewatt Transfer Switch Model FTS-1.8

- **freewatt** Transfer Switch is specifically designed for use with **freewatt PLUS** micro-combined heat and power (micro-CHP) system.
- **freewatt** Transfer Switch provides automatic transfer of electric load from utility power source to MCHP unit. No manual adjustments or switching are required by homeowner under normal operation.
- **freewatt** System Control Module and **freewatt** Transfer Switch monitor utility power source for failure.
- Monitor HONDA MCHP power source for electrical power output and proper operating conditions.
- **freewatt** Transfer Switch provides **freewatt PLUS** product line with reliable means of providing back-power to critical loads while preventing electrical feedback to utility from MCHP.
- **freewatt PLUS** provides backup power up to 1.8 kW and is limited in type, wattage, and number of loads supported.
- **freewatt** Transfer Switch certified for use as part of **freewatt PLUS** System. Only install with **freewatt PLUS** System by qualified installer.
- Consult **freewatt** Transfer Switch Installation, Operation, and Maintenance manual for installation, operating and troubleshooting information.

Figure 6-1 freewatt Transfer Switch



7 - BEFORE INSTALLING THE SYSTEM

7.1 Codes

See boiler manual for information pertaining to installation in State of Massachusetts.

System incorporates gas-fired, direct vent, condensing appliances and must be installed in accordance with the following:

Fuel Gas:

- United States: Installation shall conform to National Fuel Gas Code (NFPA-54/ANSI Z223.1).
- Canada: Installation shall be in accordance with CSA-B149.1 and B149.2 installation codes.
- Authority having jurisdiction

Electrical:

- United States: National Electrical Code (ANSI/NFPA-70).
- Canada: CAN/CSA-C22.1 Canadian Electrical Code.
- Authority having jurisdiction

Condensate Disposal:

- Authority having jurisdiction

Installers:

- Authority having jurisdiction
- Follow recommended maintenance outlined in this manual.

Grid Interconnection:

- Authority having jurisdiction with respect to interconnecting to grid.

7.2 System Sizing And Application

- Select system with proper capacity before continuing installation. Firing rate of system should be greater than or equal to calculated peak heating load (heat loss) for building or area(s) served by system. See Section 2 for system ratings.
- Base heat loss calculations on approved industry methods.
- Configure hydronic **freewatt PLUS** System with Zone 2 operated by Smart Zone HAI thermostat supplied with **freewatt PLUS** System. Zone 2, Smart Zone, must have sufficient thermal load to provide proper operation of MCHP unit. Too small of heat load in Smart Zone will result in frequent MCHP cycling and poor electrical power savings. The "Smart Zone" should be selected as zone with largest heating demand (but not domestic hot water zone). Normally, this would be largest space heating zone on first floor of two story home. **freewatt PLUS** System will produce best electric power generation benefit if Smart Zone represents about 25% of total home heating load. Consider combining zones to achieve desired heat load for Smart Zone if there is no single large zone in existing distribution system but many small zones.
- **freewatt PLUS** System must be applied with hydronic heating systems having ample heat delivery capacity relative to maximum or design heat load. This is requirement for **freewatt PLUS** and all high-efficiency hydronic systems to achieve maximum energy efficiency. "Under-radiated" system requiring high supply water temperature (above 180°F) during outdoor low-temperature design conditions will result in reduced contribution of MCHP to total heat delivery, reducing electrical power production benefit. Preferred design operating temperature is 160°F. Consider adding additional heat radiation to existing under-radiated distribution systems for proper application of **freewatt PLUS**.
- Power generation performance of **freewatt PLUS** System may be adversely affected if there is any zone resulting in constant active call for heat during heating season (i.e., highly under-radiated zone). Verify all zones have enough radiation, even during very cold weather, so no zone thermostat will produce continuous call for heat (i.e., cannot be satisfied).
- **freewatt PLUS** requires different ECR zone relay controls depending on type of zoning utilized: zoned by circulators, valves, or air handlers. Verify you have correct ECR zone relay control before beginning installation.

7 -BEFORE INSTALLING THE SYSTEM

7.3 Considerations for System Location

Before selecting location for system, following should be considered. Each system component considered for installation must be:

- Supplied with correct type of gas.
- Connected to separate (two) combustion gas vent pipes discharging to outdoors: one for **freewatt PLUS** Boiler unit and one for MCHP unit. Each vent must meet minimum and maximum vent lengths for each unit. (See Section 10).
- Connected to suitable combustion air intake piping system to supply fresh (outdoor) air for combustion (3" for **freewatt PLUS** Boiler) (not required for MCHP) (See Section 10)
- Connected to suitable forced hot water distribution system.
- Supplied with suitable 120VAC electrical supply for all system motors and controls and separate 240VAC supply for MCHP unit.
- Connected to properly located thermostat or operating control (**freewatt PLUS** requires communicating Smart Zone thermostat supplied with system and must be installed and connected to "Zone 2").
- Placed on level surface (must NOT be installed on carpeting).
- Condensate drain line must be pitched down to floor drain or external condensate pump with reservoir at ¼" per foot (wood frame or concrete blocks may be used to raise boiler). MCHP unit must be bolted to concrete floor as specified.

7.4 Locating the System

- Select level location central to distribution system and close to vent and air intake terminals.
- Use accessibility clearances for system installation, if more stringent (i.e. larger clearances) than required fire protection clearances.
- Must install MCHP unit on solid, concrete floor with adequate make-up air available for 18,500 Btu/hr net input heating appliance. System shall not be installed on carpeting. Shimming should be done between base and MCHP, not between base and floor.
- Install equipment in location facilitating operation of venting and combustion air intake piping systems described in this manual (Section 10).

- Advise owner to keep venting and combustion air intake passageways free of obstructions. Both venting and combustion air intake piping systems connected to outdoors must permit flow through piping systems without restrictions for system to operate.
- Install control module and switching components to protect from water (dripping, spraying, rain, etc.) during operation and service (pump replacement, MCHP maintenance, etc.).
- Locate system where ambient room temperatures (minimum possible temperatures where system is installed assuming system is not in operation and therefore contributes no heat to space) are at or above 32°F to prevent freezing of liquid condensate.

7.5 Combustion Air and Vent Pipe Requirements

- System requires dedicated direct vent system for boiler and separate vent for HONDA MCHP to discharge all combustion products to outside atmosphere.
- Boiler requires combustion air intake to complete its sealed combustion direct-vent system and provide air from outdoors. HONDA MCHP requires make-up air from installation space.

CAUTION

Keep system area clean of debris and free of flammable and combustible materials, vapors and liquids.

- Combustion air supply and boiler vent pipes must terminate together in same atmospheric pressure zone, through roof or sidewall (roof termination preferred). Boiler and MCHP vent terminations may be at different locations, feature may assist in locating appropriate venting locations. Consult boiler and HONDA MCHP Installation Manuals for specific guidelines for required clearances and installation instructions.
- Refer to boiler Installation, Operation and Maintenance Manual for guidelines regarding concentric vent termination installation and guidelines.

7 -BEFORE INSTALLING THE SYSTEM

7.6 Condensate Drain Requirements

- Install condensate drain lines with pitch down to floor at minimum of ¼" per foot.
- External condensate pump (not furnished) may be used if floor drain is not available. One condensate pump can be used for both boiler and MCHP.
- Use condensate pump designed for flue gas condensate application.
- Consult boiler and Honda MCHP Installation Manuals for guidelines for condensate drain installation.

NOTICE

It is recommended no additional electrical connections be made within **freewatt PLUS** System for line power. Separate junction box and receptacle should be provided if line power is required for condensate pump,.

7.7 Foundation Requirements

- Place system on level concrete surface. DO NOT install on carpeting.
- System: Level System will allow the condensate drain lines to function properly. Shims should be used between boiler, floor, MCHP and base to make up for minor surface irregularities or tilt.
- HI Module: The HI Module will be mounted on boiler or nearby wall.
- Honda MCHP: Honda MCHP is supplied with a base to raise unit above floor and secure to concrete floor.

7.8 Removal of Existing Furnace from Common Vent System

Existing common venting system is likely to be too large for proper venting of appliances remaining connected to it. Refer to decommissioning procedure outlined in boiler Installation, Operation and Maintenance manual.

7.9 Requirements for Hydro-air Applications:

- Application of **freewatt PLUS** with Hydro-Air System Air Handler as Smart Zone requires Smart Zone Air Handler be of type powered with ECM blower motor.
- VHBXB Air Handlers manufactured by First Co. having ECM blower motor are known to work with **freewatt PLUS** System.
- Consult factory for additional information before application of other air handlers with Smart Zone of **freewatt PLUS** System.

8 - PLACING THE SYSTEM

8.1 Place system to provide direct connections to:

- combustion air/vent piping system,
- natural gas piping,
- return and supply duct-work,
- condensate removal system,
- electrical connections.

8.2 Instructions for preparation and placement of Hydronic freewatt PLUS System:

- Determine location for boiler, MCHP and indirect hot water tank (if used), identify location for hydronic HI module, relay switches and circulators. Typical configuration for Hydronic **freewatt PLUS** System is shown in Figure 2-1.
- Place crated boiler and HONDA MCHP unit as close to selected location as possible and un-crate units.
- Follow instructions outlined in **freewatt PLUS** Boiler Installation, Operation and Maintenance Manual for placing boiler. See Figure 2-2 for boiler details.
- System configuration and final placement should allow for future servicing of equipment.
- See Figure 8-2 for typical piping schematic to assist in determining layout of **freewatt PLUS** system components.
- Reference HONDA MCHP Installation Manual for instructions regarding placement.
- Install MCHP unit base as specified in HONDA MCHP, Model YM2Z, Installation Manual and Owner's Manual as summarized below and Figure 8-1.
 - Place base on concrete floor and level.
 - Mark anchor bolt locations on concrete floor.
 - Drill hole diameters in concrete for anchor bolts per manufacturer's installation instructions. If obstruction is hit, move base and re-drill.
 - Attach base to anchor bolts with supplied hardware.
 - Locate washers between MCHP and base if unit needs to be shimmed level.
 - Orientation of bolt & nut is important. Bolt must be installed from top with nut on bottom. Use nuts and bolts supplied in installation kit. Do not use shipping bolts which attach MCHP to shipping pallet.
 - Do not make penetrations or drill holes in MCHP unit cabinet.

CAUTION

Penetration or modifications of MCHP cabinet will result in potential electrical or fire hazard. Do not attach controls, wire, piping, conduit or other hardware to MCHP unit.

- Place HONDA MCHP on base and secure MCHP unit to base with supplied hardware after base installed. See Figure 8-1.
- Determine location of Hydronic HI Module enclosure. Mount enclosure on solid wall or partition. Recommend enclosure be located close to HONDA MCHP. HI module may be mounted up to 10 feet away from HONDA MCHP unit. Locate enclosure with installation and service accessibility in mind.
 - Hydronic HI Module bottom should be installed at height of 32" to 42" above floor elevation where base of HONDA MCHP is installed.
 - Ensure top of Hydronic Hybrid Integration (HI) module is mounted above Honda MCHP's top cover. HI Module bottom should not be above MCHP top.
 - Hydronic piping between HI module and primary hydronic loop manifold should not exceed 40 feet. Piping and circulator should be designed for water flow rate of 4gpm. HI module heat exchanger pressure drop is approximately 1 psi.
 - Position enclosure, check for level, mark mounting holes.
 - Start screws (#10 ,4 each, field source) for keyhole type mounting holes in upper corner(s). Tighten screws down to about 1/8" (3mm) from surface.
 - Hang enclosure on screws, position enclosure and start bottom screws.
 - Tighten all screws.

Figure 5-1 MCHP Base Installation

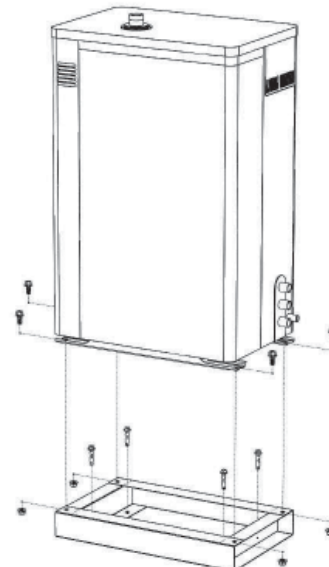

8 - PLACING THE SYSTEM

8.3 freewatt PLUS System Piping

- Place equipment in proper locations.
- Configure system piping to connect boiler and HONDA MCHP to distribution piping.
- Hydronic **freewatt PLUS** piping configuration is modified primary-secondary, allowing heat from MCHP unit be injected into return piping upstream from **freewatt PLUS** boiler. Configuration ensures coldest return water be delivered to MCHP unit's hydronic hybrid integration (HI) module.

- Figure 8-2 shows **freewatt PLUS** distribution piping schematic for system zoned with zone valves for heating zones and priority pump for indirect water heater zone. Configuration of heating zones, boiler and MCHP heat sources shown is mandatory for proper operation of **freewatt PLUS** System.
- See piping schematics in Section 17 for circulator zoned systems, valve zoned systems and systems with air handlers.

Figure 8-2 Hydronic Freewatt PLUS System Distribution Piping Schematic with Zone Valves and Priority DHW Pump

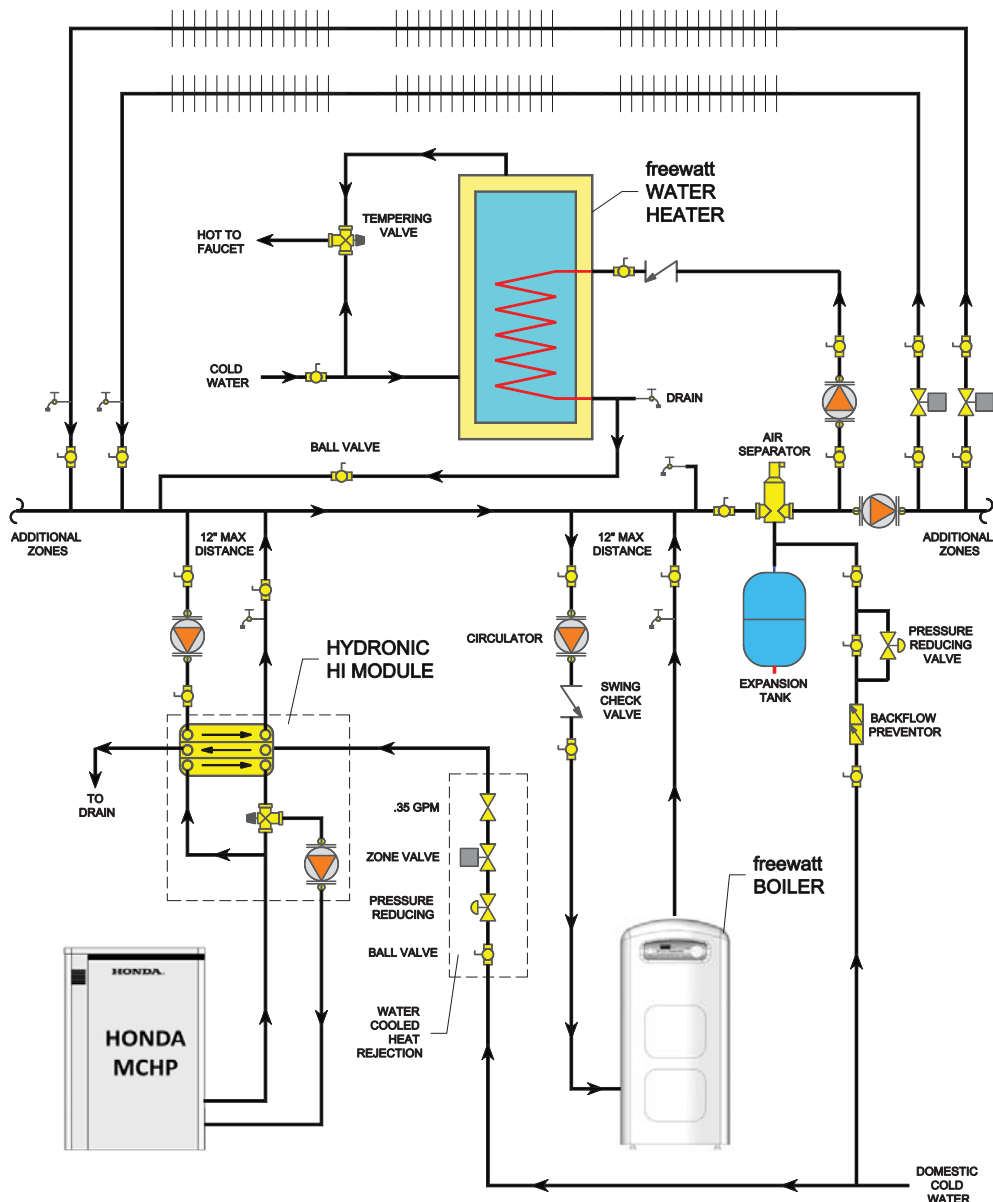

8 - PLACING THE SYSTEM

8.4 Design Tips

- Install bottom of Hydronic HI Module at height of 32" to 42" above floor elevation where HONDA MCHP installed.
- Maximum 10ft. length of ½" Onix coolant tubing connecting Hydronic HI module and MCHP.
- Install mixing valve if indirect hot water tank is installed. Mixing valve will provide anti-scalding protection and allow for summer operation of MCHP unit. Review installation requirements supplied with Indirect Water Tank.

8.5 Near Boiler Piping

- Do not install Copper piping directly into aluminum boiler casting due to galvanic corrosion between dissimilar metals. Two (2) dielectric isolation unions shipped loose in boiler parts bag. Install dielectric isolation unions at boiler supply and return line. Use of dielectric unions is required. **freewatt PLUS** boiler furnished with iron piping where necessary for supply and return connections.
- Configure near boiler piping in accordance with **freewatt PLUS** Boiler's Installation, Operation and Maintenance Manual. Overall configuration with MCHP unit and heated zones must be in conformance with Figure 8-2.
- **freewatt PLUS** Boiler provided with 1 ¼" NPT return and supply piping connections shown in Figure 2-2.
- **freewatt PLUS** Boiler Installation, Operation and Maintenance Manual includes directions on distribution system requirements, including expansion tank, make-up water, air separator, air vent and condensate drain piping (pump).
- Install 1 ¼" ball valves on supply and return legs of boiler connection to allow for servicing of boiler or circulators.

8.6 Honda MCHP & Hydronic HI Module

- Install MCHP near piping in accordance with HONDA MCHP installation manual and instructions found in this section.
- Typical piping configuration is shown in Figure 2-1, shows MCHP connecting to hydronic HI Module. Hydronic HI Module connects to hydronic water distribution system.
- Place hydronic HI module in location allowing MCHP to connect with maximum 10 feet of ½" Onix tubing, while also located vertically above MCHP unit (32" to 42" above MCHP's base level).
- Onix tubing used to isolate vibrations from Honda MCHP unit and is provided with installation kit.

NOTICE

Use only long life coolant supplied with **freewatt PLUS** System. Use of any other coolant will void warranty.

System will not operate properly and permanent damage to Hydronic HI Module or HONDA MCHP may occur if followings steps are not followed.

Following steps are required to install long life coolant (LLC) tubing between Hydronic HI module and HONDA MCHP.

Figure 8-3 MCHP Coolant Loop Drain Tee (LLC-Long Life Coolant Supplied with System)

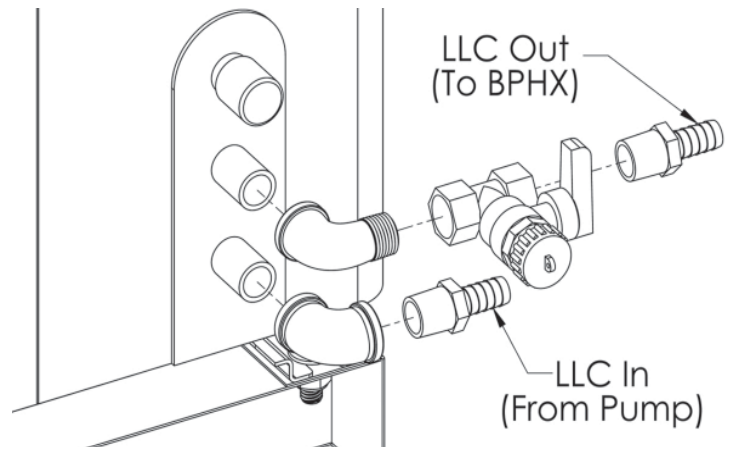

8.7 HI Module coolant tubing:

- Prepare rear connections (LLC In and LLC Out) of MCHP unit with pipe thread sealant. Install ½" NPT brass street elbow onto drain fitting before installing 1/2" NPT street elbow onto MCHP unit's 1/2" MNPT LLC Out fitting. Install other 1/2" NPT brass elbow onto MCHP unit's LLC In fitting. Install 1/2" NPT x 1/2" barb fittings into drain fitting and 1/2" NPT elbow. Point fittings in direction of front of hydronic HI Module. Figures 8-3, 8-4 and 8-5.
- Long Life Coolant **Out** Tubing Installation [MCHP to BPHX; Figure 8-5]:
 - Attach supplied 1/2" brass Tee to threaded heat exchanger fitting located on bottom of HI Module as shown. (Apply pipe thread compound)
 - Attach supplied 1/2" NPT x barb fittings to remaining threads on brass Tee. (Apply pipe thread compound)
 - Attach supplied 12.5" length of tubing to front of brass tee. Route cable through sheet metal as shown. Attach stackable hose barb fitting and insert into HOT side of mixing valve. Secure fittings using tubing clamps.
 - Install Onix™ tubing from top rear LLC connection on MCHP, to hose barb on bottom of tee. Secure

8 - PLACING THE SYSTEM

Figure 8-4 MCHP Coolant Line Installation Instructions

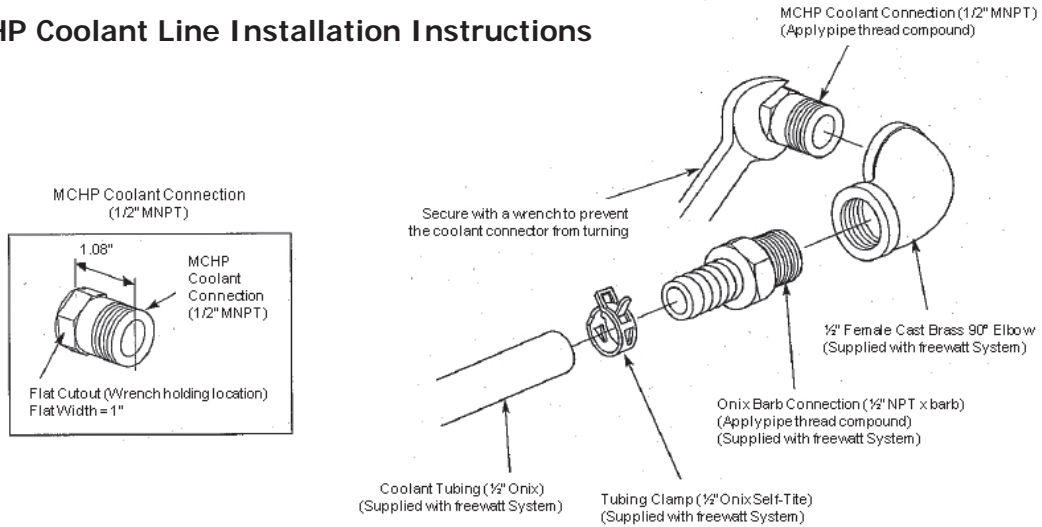

Figure 8-5 LLC Out Connection to HHI Module (BPHX)

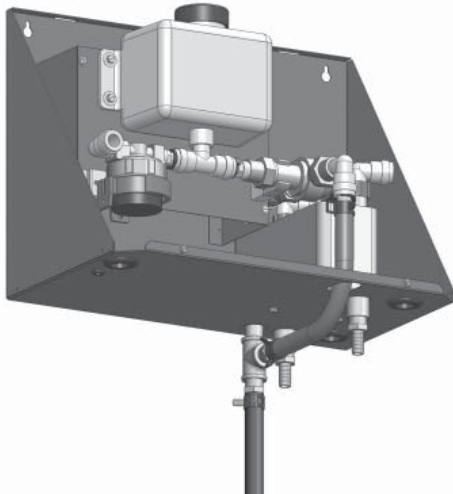

Figure 8-6 LLC In Connection to Pump

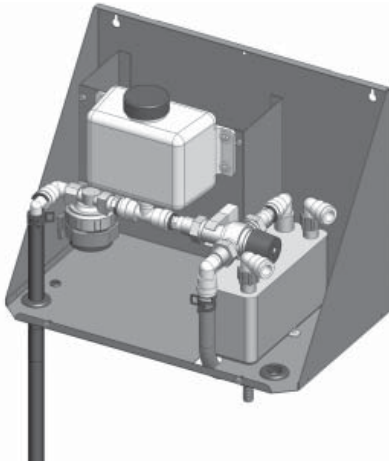

Figure 8-7 - Hose Barb by IPS Elbow Fitting



Figure 8-8 Female Swivel Fitting (NPT by IPS)



using tubing clamp.

- Long Life Coolant **In** Tubing Installation: [Pump to MCHP; Figure 8-6]
 - Cut section of Onix Tubing to extend from MCHP unit's lower Coolant connection to coolant pump in HI Module.
 - Install barbed end of elbow (barb x IPS) fitting into open tube end of tubing and secure with SelfTite clamp. Figures 8-7 and 8-8
 - Route tubing through hole in bottom of Hydronic HI Module.
 - Insert IPS end of same elbow (barb x IPS) fitting into female IPS swivel fitting (Figure 8-7 and 8-8) on coolant pump and secure with collet clip supplied with female swivel fitting.
 - Route tubing to rear of MCHP (if necessary through open channel in front of MCHP base) and cut to length.
 - Install tubing onto lower brass hose barb fitting (LLC In) and secure SelfTite clamp onto tubing.

Use only Watts Radiant brass barb fittings with Onix tubing supplied with **freewatt PLUS** System. Off-the-shelf brass fittings are made to different dimensions and tolerances, which may result in leaks.

8- PLACING THE SYSTEM

8.8 HHI Module to Distribution Manifold

- Follow industry standards when installing distribution manifold.
- Install MCHP hydronic pump below manifold to prevent circulator from air locking.
- Size tubing or piping connecting Hybrid HI module with distribution manifold ½" NPT or larger to provide adequate flow for transfer of heat from MCHP's coolant into hydronic water.
- Pump shall provide flow of at least 4 gpm to brazed plate heat exchanger (~1 psi Pressure Drop) in Hydronic HI Module. Grundfos SuperBrute Pump (UPS1558FC) is suggested.
- See Figure 8-9 design example of piping.
- Installation
 - A. Attach two supplied 1/2" NPT X barb fittings to threads on bottom of heat exchanger per Figure 8-11. Apply pipe thread compound.
 - B. Attach Onix tubing to barbs securing with Selftite clamps.

Figure 8-9 HI Module to Distribution Manifold Piping

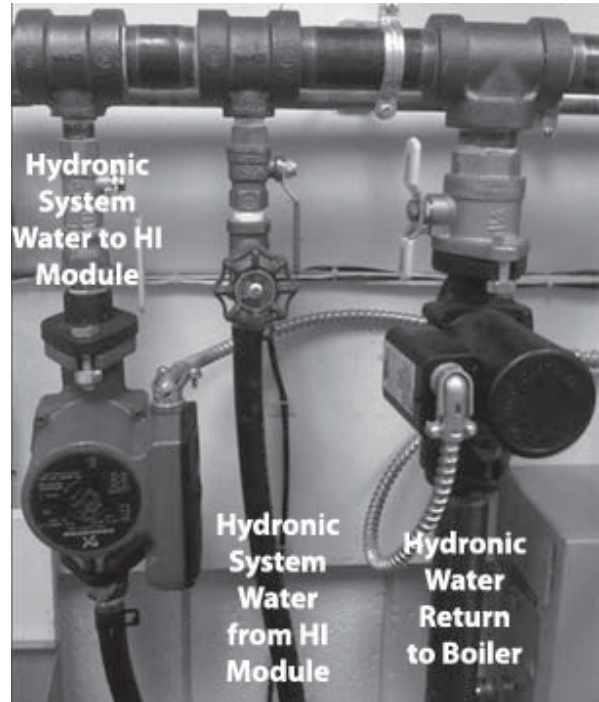

8.9 HHI Module Heat Rejection System Connections

NOTICE

Follow these steps to ensure proper system operation and prevent permanent damage to Hydronic HI Module or Honda MCHP.

NOTICE

Follow detailed instructions provided with heat rejection accessory kit to construct heat rejection piping loop.

Following steps are required to connect heat rejection system to Hydronic HI Module for Heat Rejection cooling.

- Install pipe or tubing from supplied heat rejection loop to BPHX. Ensure counter flow between heat rejection fluid and MCHP Coolant. See Figure 8-12.
- Install pipe or tubing from outlet of BPHX to heat rejection loop.

Figure 8-10 Condensate Lines



8.10 Condensate Drain Piping

NOTICE

Boiler and MCHP's drain trap assembly must be filled with water before operating system. Dry trap may cause pressure switches to behave erratically, preventing boiler from operating normally, or cause exhaust products to enter building space.

Figure 8-11 Hydronic freewatt® PLUS HI Module

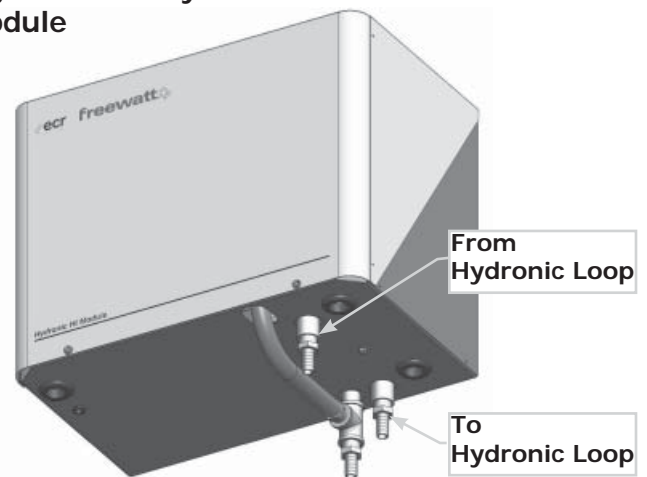

8 - PLACING THE SYSTEM

Figure 8-12 Heat Rejection Connections to HHI Module (BPHX)

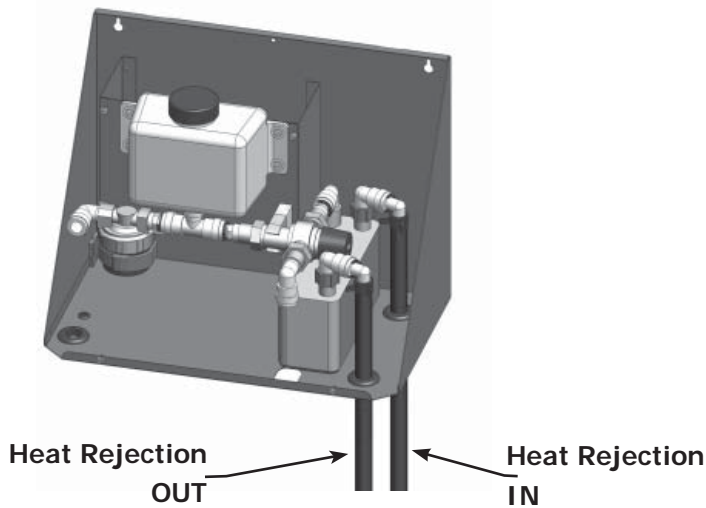

- **freewatt PLUS** boiler and MCHP unit will produce condensate at rates up to 2 ½ US quarts per hour. Make provisions to drain condensate away from both boiler and MCHP to ensure proper operation. Boiler is supplied with factory-installed drain trap assembly with ½" dia. Sch. 40 PVC connection.
- Install MCHP condensate line directly into condensate pump, located directly behind MCHP unit, if floor drain is not available. Condensate line should have "Y connector" to ensure tubing is open to atmosphere, removing chance for air lock in line. Figure 8-10. Route boiler's condensate line behind MCHP unit and install directly into condensate pump.
- Supplied boiler condensate vent drain T must be used.
- Do not make any additional electrical connections within **freewatt PLUS** System for 120 VAC power. Separate junction box and receptacle should be provided if 120 VAC power is required for condensate pump.
- Review installation instructions for boiler and HONDA MCHP to ensure a proper installation.

8.11 Onix Clamps

- Do not use screw gun or wrench to tighten TorqueTite clamps.
- Safety glasses must be worn when installing SelfTite Clamps.
- Minimum bending radius of ½" Onix tubing is 4".
- Onix requires special Torque-Tite or Self-Tite mechanical clamps, designed for higher temperature and burst pressure ratings.
- Self-Tite clamps are supplied with **freewatt PLUS** System.
 - TorqueTite clamps are heavy-duty screw-type, wide-band, stainless steel clamps. In. per lb. torque wrench is required to install. Tightened each clamp according to proper torque setting for size of clamp used. Torque settings are listed on instruction sheet supplied with clamps.
 - Do not over tighten TorqueTite clamp. Overtightening may cause long-term damage to Onix tubing and/or to clamp itself.
- SelfTite Clamps are chrome-vanadium, constant tension clamps. Watts Radiant recommends using SqueezeTite pliers to properly open and install clamps.
 - Do not allow clamp to flatten while being held open. Flattened clamps will not fit properly over Onix and barb assembly.

8 - PLACING THE SYSTEM

- All Onix and brass fitting surfaces must be clean and dry before making connection.
- Avoid making connections or splices in inaccessible locations.
- Repairing Onix having been in service in **freewatt PLUS** System requires special attention. Any residual amounts of **freewatt PLUS** long life coolant inside Onix tube must be removed. Use an alcohol swab or pad to remove residue(s), allow tube to dry prior to connection.

NOTICE

Do not solder near, or overheat, any Onix connections. Extreme temperatures associated with soldering may seriously damage Onix and will void warranty.

- Expand ECR control using appropriate ECR expansion relay controls if additional zones are needed.
- Two air handlers with circulators can be accommodated through use ECR ARH-3 control.
 - One air handler must be "Zone 2 - Smart Zone".
 - If additional zones are needed, expand ECR control using appropriate ECR expansion relay controls.
- Select "Smart Zone" as zone with largest heating demand (but not domestic hot water zone). This would normally be largest space in heating zone on first floor of two story home. **freewatt PLUS** System will produce best electric power generation benefit if Smart Zone represents 25% of total home heating load. If there is no single large zone in existing distribution system, but many small zones, consider combining zones to achieve desired heat load for the Smart Zone.

8.12 Configuration of Heating Zones and Controls

- Hydronic **freewatt PLUS** System may be applied to variety of heating loads served by conventional, multi-zone hydronic heating systems. Including base-board radiation, radiant floor heating, domestic hot water via indirect storage tank, powered convective heaters, hydro coils, and others.
- Use correct ECR zone control accessory kit, ordered separately, for type of zoning to be applied with hydronic **freewatt PLUS** System. Kit includes **freewatt** smart zone communicating thermostat, AR822-II pump relay for MCHP hydronic loop pump, and appropriate zone control relay as follows:
 - Use Zone Pump Zone Control Accessory Kit which includes ARM-6P for pump zoned systems,
 - Use Zone Valve Zone Control Accessory Kit which includes AZ-6CP for valve zoned systems,
 - Use Hydro-Air Zone Control Accessory Kit which includes ARH-3 for distribution systems with air handlers.
- Thermostats for up to six zones, must be wired through **freewatt PLUS** Control Module.
 - One zone of six zones must designated "Zone 2 - Smart Zone".
 - Zone 1 is used to accommodate indirect water heater having its own dedicated circulation pump.
- Required ECR heating zone relay controls for use with pumped zoned systems (ARM-6P) and valve zone systems (AZ-6CP) can accommodate total of 6 zones.

Installations of Hydronic **freewatt PLUS** System require use of AR-822-II for operation of circulator that provides hydronic water flow to HI Module.

9 - EXHAUST GAS LEAK SENSOR

9.1 EGLS Introduction

- Exhaust Gas Leak Sensor System in addition to separate, independently installed and operating UL approved Carbon Monoxide Detector having audible alarm.
- Install both Exhaust Gas Leak Sensor (supplied with **freewatt PLUS**) and audible UL approved Carbon Monoxide Detector (not supplied with **freewatt PLUS**).
- **freewatt PLUS** System and **freewatt PLUS** Exhaust Gas Leak Sensor do not provide audible alarms for protection of building inhabitants from potential high CO hazards.
- Function of **freewatt PLUS** Exhaust Gas Leak Sensor System is to automatically stop operation of MCHP unit in event it detects potentially hazardous level of carbon monoxide in vicinity of MCHP unit.
- **freewatt PLUS** System Exhaust Gas Leak Sensor System uses Macurco CO Detector connected directly to Honda MCHP Unit. Read following installation instructions:
 - Read and understand installation and operation manual for Macurco CO Detector part of Exhaust Gas Leak Sensor System.
 - Install Macurco CO Detector per manufacturer's instructions in close proximity of HONDA MCHP unit.
 - Install four-wire cable from HONDA MCHP to Macurco CO Detector.
 - Verify cable properly secured (Maximum interval: every 3 ft.)
- Exhaust Gas Leak Sensor (EGLS) monitors integrity of MCHP unit's combustion system shutting down MCHP unit if potentially unsafe conditions are detected.
 - Monitors carbon monoxide level in air space near MCHP unit. EGLS is independent of, and separate from, audible CO alarming system that must be installed with **freewatt PLUS** System in compliance with best practices for all fuel-fired central heating equipment.

WARNING

freewatt PLUS Exhaust Leak Gas Sensor does not fulfill State of Massachusetts's CO detector and alarm requirement. Exhaust Gas Leak Sensor does not provide an audible alarm for potentially hazardous CO levels.

- Exhaust Gas Leak Sensor is supplied with Hydronic **freewatt PLUS** System and is intended for installation in close proximity of HONDA MCHP unit.

- Figure 9-1 shows connections to Exhaust Gas Leak Sensor. Exhaust Gas Sensor will automatically stop operation of MCHP unit upon detection of potentially dangerous levels of carbon monoxide gas regardless of source of carbon monoxide gas.

9.2 Preparation

Following items must be installed before Exhaust Gas Leak Sensor can be installed:

- Boiler, Control Module & Hydronic HI Module
- Honda MCHP Unit
- Thermostat

WARNING

Exhaust Gas Leak Sensor does not fulfill independent CO detector and audible alarm requirement of **freewatt PLUS** System. **freewatt PLUS** System requires separate CO alarm for protection of building inhabitants. Separate **freewatt PLUS** System installation requirement is fulfilled by complying with State of Massachusetts's CO detector and alarm requirements. Your state or local jurisdiction may have additional requirements regarding carbon monoxide detectors and alarms.

9.3 Installation

Exhaust Gas Leak Sensor is connected to HONDA MCHP unit using four conductor stranded insulated cable supplied by Honda. Follow installation instructions below to ensure proper operation of Exhaust Gas Leak Sensor:

Honda MCHP Connection

- 4-pin cable connector to the HONDA MCHP for the Exhaust Gas Leak Sensor is factory-supplied and field installed. The HONDA MCHP installation kit includes an electrical schematic for the wiring details.
- See HONDA MCHP Installation manual for the connections to the HONDA MCHP and for any servicing or troubleshooting.

Exhaust Gas Leak Sensor Connections

- Field install cable connection to Exhaust Gas Leak Sensor after installation of sensor. Figure 9-1 shows field connections of supplied cable to Exhaust Gas Leak Sensor.
- See MCHP Installation manual for connections to HONDA MCHP for servicing or troubleshooting.
- Field install jumper wire between second terminal (F) and fourth terminal (N.C.). May need to install another Jumper between COM and B terminals instead of using crimp.

9 - EXHAUST GAS LEAK SENSOR

NOTICE

Exhaust Gas Sensor's cable connections must be installed properly or Hydronic **freewatt PLUS** System will not initialize and not operate (ERROR – 14 or 15 Flashes).

For more instructions on connecting Exhaust Gas Leak Sensor SEE MCHP IOM.

9.4 Test Procedure

Test Exhaust Gas Leak Sensor to ensure proper operation before commissioning system. Use Exhaust Gas Leak Sensor test button in accordance with procedure below. Procedure will stop MCHP unit. See "Troubleshooting" Section 16 if MCHP unit does not stop,.

1. Disconnect **freewatt PLUS** System from Internet. Temporarily disconnect LAN (local area network) cable from side of **freewatt** Control module or disconnect LAN cable where it plugs into home's network.
2. Power is supplied to Exhaust Gas Leak Sensor by MCHP. MCHP must be operating during testing of Exhaust Gas Leak Sensor. Turn thermostat up until MCHP operates, if MCHP is not operating.
3. Wait for LED on Macurco CO Detector to begin glowing green. Press button on Exhaust Gas Leak Sensor labeled "Push Here to Test or Reset" for 6 seconds, when LED on Macurco CO Detector is glowing green continuously. This should cause **freewatt PLUS** System error condition.

NOTICE

LED indicator on Exhaust Gas Sensor must be solid green. Sensor is initializing if it is flashing red and green. Wait 3 minutes until LED is solid green before proceeding.

4. Confirm HONDA MCHP unit has stopped operating, and red "Service Required" LED on **freewatt PLUS** System's front panel is blinking error code "16", and yellow "Bypass" LED is on.
5. Clear error condition. Turn OFF 120 VAC **freewatt PLUS** System Service Switch and 240 VAC Honda MCHP Service Switch.
6. Reconnect LAN cable to **freewatt PLUS** System.
7. Turn power ON to HONDA MCHP 240 VAC Service Switch, turn ON **freewatt PLUS** System 120 VAC Service Switch, to return system to normal operation.

Exhaust Gas Sensor must be replaced every 5 years with identical unit, installed by qualified and properly trained service personnel.

freewatt PLUS generator will stop and red service required LED will indicate fault by flashing 16 times if you push test button on **freewatt PLUS** Exhaust Gas Leak Sensor.

Fault message will be transmitted to **freewatt PLUS** service center if your system is connected to internet. Clear fault condition to restore MCHP operation. Shut off electrical power to **freewatt PLUS** System and restore power to reset system using power switch on **freewatt** Control module to clear fault.

Figure 9-1 Exhaust Gas Leak Sensor Connections

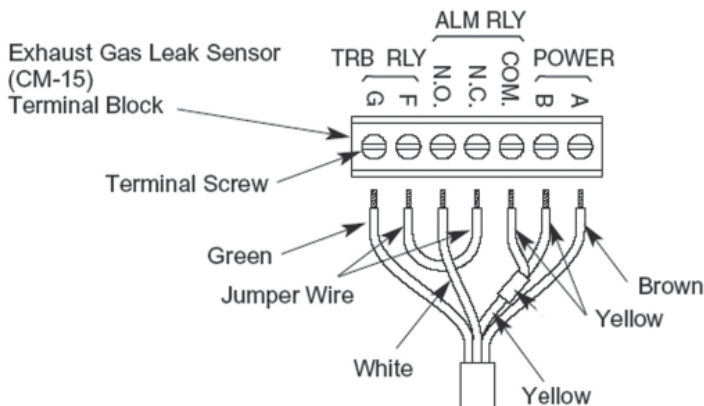

10 - COMBUSTION AIR AND VENT PIPE

WARNING

Read, understand and follow all instructions. Failure to properly vent or supply combustion air to boiler can cause carbon monoxide poisoning, or an explosion or fire, personal injury or loss of life.

10.1 General Considerations

- Perform tasks outlined in Section 5 of **freewatt PLUS** boiler Installation, Operation and Maintenance Manual, section "Removal of Existing Boiler from Common Vent System" if system will be replacing Category I type boiler connected to chimney serving other appliances.
- Vent installations shall be in accordance with ANSI Z223.1/NFPA 54, CSA-B149.1 and B149.2, or authority having jurisdiction.
- Provisions for combustion and ventilation air shall be in accordance ANSI Z223.1/NFPA 54, CSA-B149.1 and B149.2, or authority having jurisdiction.
- Hydronic **freewatt PLUS** System has two separate components requiring combustion air and discharge of combustion products.
 - Boiler component requires dedicated direct vent system. All air for boiler's combustion is taken directly from outdoors through combustion air intake pipe. All combustion products are discharged to outdoors through vent pipe.
 - Honda MCHP takes combustion air from interior open space and all combustion products are discharged to outdoors through vent pipe.
- See installation instructions in boiler and HONDA MCHP manuals for combustion air and vent pipe roof and sidewall termination (Roof termination is preferred). Combustion air and vent pipes for **freewatt PLUS** Boiler must terminate together in same atmospheric pressure zone as shown. Boiler and MCHP exhaust vents need not be in same general location on exterior of building. Construction through which vent and air intake pipes may be installed is maximum 24 inches, minimum ¼" thickness.
- Combustion air and vent pipe fittings must conform to American National Standards Institute (ANSI) and American Society for Testing and Materials (ASTM) D1784 (schedule 40 CPVC), D1785 (schedule 40 PVC), D2665 (PVC-DWV), D2241 (SDR-21 and SDR-26 PVC), D2661 (ABS-DWV), or F628 (schedule 40 ABS). Pipe cement and primer must conform to ASTM standards D2564 (PVC) or D2235 (ABS). In Canada construct all combustion air and vent pipes for system of CSA or ULC certified schedule-40 CPVC, schedule-40 PVC, PVC-DWV or ABS-DWV pipe and pipe cement. SDR pipe is not approved in CANADA.

- Combustion air pipe and vent connections on boiler are 2" pipe size. Installed combustion air pipe and vents for boiler must be 3" size and, 2" to 3" pipe coupling must be used at boiler connections. MCHP vent connection size is 2". 2" or 1-1/2" vent size is permitted. Refer to **freewatt PLUS** Boiler Installation, Operation and Maintenance Manual and MCHP IOM for specific venting instructions.
- Exhaust transition from 2" pipe to 3" pipe must be made in vertical run. Transition pieces are not included. (See boiler installation manual for more details.)

10.2 Combustion and Vent Piping Length

Refer to direct vent and non-direct combustion air and vent sections outlined in installation guides for boiler and Honda MCHP for specific installation procedures and specifications.

10.3 Installation

- Refer to direct vent and non-direct combustion air and vent sections outlined in installation guides for boiler and HONDA MCHP for specific installation procedures and specifications. General guidelines for air intake and vent piping are found in **FW95M-200 Boiler Installation, Operation and Maintenance Manual**.
- Use of periscopes on air intake and venting are allowed. Insulate periscopes with proper weather-resistant pipe insulation if extend over 24" in length, straight length.

10.4 freewatt PLUS System Combustion Air and Venting

Combustion air and venting installation procedures and specifications are based on installation specifications of boiler and MCHP. Installers are required to follow specific installation requirements found in boiler and MCHP installation manuals, following guidelines are taken from these manuals.

10.5 United States Direct Vent System Requirements

Boiler direct vent exhaust shall be installed in United States in accordance with following requirements. Allowable direct vent intake and exhaust piping lengths for boiler are found in FW95M-200 Boiler Installation, Operation and Maintenance Manual.

10 - COMBUSTION AIR AND VENT PIPE

NOTICE

Install boiler per Direct Venting requirements.
Install MCHP per Non-Direct Venting Requirements.
Distinction is noted to ensure proper location of vent terminations.

- Clearance from bottom of termination to grade shall be 12" or increased to maintain 12" above anticipated accumulated snow level.
- Vent shall not terminate over public walkways or over area where condensate or vapor could create nuisance or hazard.
- Vent termination shall be installed at least 1 foot from any opening through which flue gases could enter building.
- Vent termination shall have minimum horizontal clearance of 4 feet from electric meters, gas meters, regulators and relief equipment.
- Locate vent terminal 3 feet horizontally from vent of any side wall vented fuel gas appliance or clothes dryer, except in case of hydronic **freewatt PLUS** System where boiler and MCHP vents may be located with respect to each other per Figures 10-1 or 10-2.

10.6 United States Non-Direct Vent System Requirements

Non-direct vent exhaust for MCHP shall be installed in United States accordance with following requirements; non-direct vent exhaust piping lengths for MCHP are found in Honda MCHP Installation Manual:

- Clearance from bottom of termination to grade shall be 12" or increased to maintain 12" above anticipated accumulated snow level.
- Vent shall not terminate over public walkways or over area where condensate or vapor could create nuisance or hazard.
- Vent termination shall be installed at least 4 feet below, 4 feet horizontally from, or 1 foot above any door, window, soffit, under eave vent or gravity air inlet to the building.
- Vent termination shall have minimum horizontal clearance of 4 feet from electric meters, gas meters, regulators and relief equipment.
- Locate vent terminal 3 feet horizontally from vent of any side wall vented fuel gas appliance or clothes dryer, except in case of hydronic **freewatt Plus** system where boiler and MCHP vents may be located with respect to each other per figures 10-1 or 10-2.

Figure 10-1

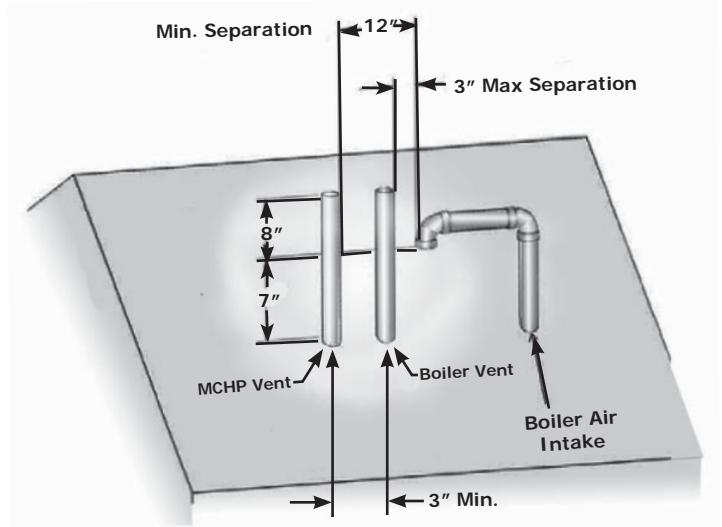
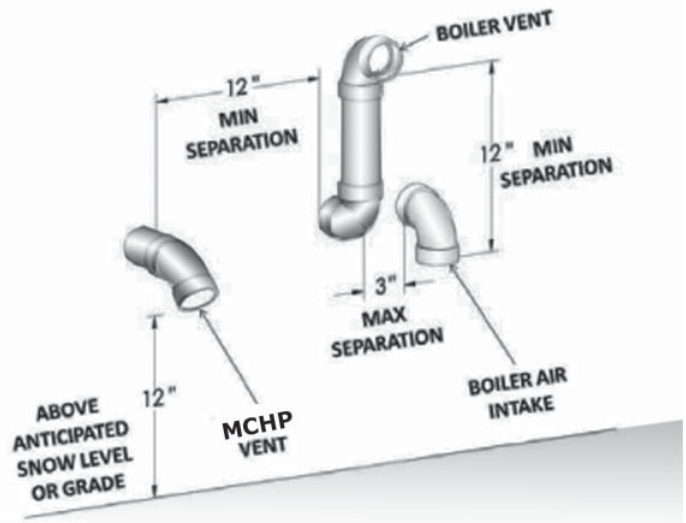

Figure 10-2



11 - GAS SUPPLY PIPING

CAUTION

Units cannot operate properly or safely using fuels outside normal commercial standards. Connect boiler and HONDA MCHP units only to gas supplied by commercial utility or supplier. Private gas wells do not generally provide gas with consistent, uniform and predictable heating values and densities. Many non-commercial wells contain impurities such as sulphur, which may damage furnace or HONDA MCHP.

11.1 Check Gas Supply

- Gas pipe to boiler must be correct size for length of run and for total BTU per hour input of all gas utilization equipment connected to piping. See Tables in boiler and HONDA MCHP installation manuals for proper size. Verify gas line complies with authority having jurisdiction.
- **freewatt PLUS** Boiler and MCHP units' individual shutoff valves must be disconnected from gas supply piping system during any pressure testing of system at test pressures in excess of ½ psig (3.5 kPa).
- **freewatt PLUS** Boiler and MCHP unit system must be isolated from gas supply piping system by closing respective individual manual shutoff valves during any pressure testing of gas supply piping system at test pressures less than or equal to ½ psig (3.5 kPa).
- Recommend line pressure be within minimum and maximum values in Table 11-1 for proper operation of system.

Table 11-1 Gas Supply Pressures

Gas tyoe	Minimum (in. w.c.)	Nominal (in. w.c.)	Maximum (in. w.c.)
Natural	4"	7"	10"
Propane	10"	12"	14"

Consult boiler and HONDA MCHP installation procedures for leak testing and purging gas lines.

11.2 Gas Piping

Consult boiler and HONDA MCHP installation procedures for specific instructions regarding gas piping.

12 - ELECTRICAL WIRING & CONNECTIONS

⚠ WARNING

Electric shock hazard. For your safety, turn off electrical power supply at service panel before making any electrical connections. Failure to do so can cause severe personal injury or death.

12.1 Codes

Installation must comply with National Electrical Code, authority having jurisdiction, and in Canada, with CSA C22.1 Canadian Electrical Code and authority having jurisdiction.

NOTICE

Wiring shall be N.E.C Class 1. Use only type 105°C wire or equivalent if original boiler wiring must be replaced. System shall be electrically grounded as required by National Electric Code ANSI/NFPA 70.

12.2 Line Voltage Connections

System installation must include :

- 120 VAC dedicated circuit (15 amp) to Boiler, control module, circulator pumps and relay switches.
- 120 VAC dedicated circuit will extend up to freewatt Transfer Switch.
- 240 VAC dedicated circuit (2 pole; 15 amp) to HONDA MCHP unit.
- 240 VAC dedicated circuit shall have serviceman's switch field installed near Honda MCHP on circuit between main service panel and freewatt Transfer Switch.

9.3 Line Voltage Wiring Specifications

- 240 VAC Wiring: All wiring must conform to National Electric Code and authority having jurisdiction. Wiring must be N.E.C. Class 1. In Canada, C.S.A. C22.1 Canadian Electrical Code Part 1 and authority having jurisdiction. Wiring must be C.S.A. C22.1 C.E.C. Part 1.
- 120 VAC Wiring: All wiring must conform to National Electric Code and authority having jurisdiction. Wiring must be N.E.C. Class 1. In Canada, C.S.A. C22.1 Canadian Electrical Code Part 1 authority having jurisdiction must be followed. Wiring must be C.S.A. C22.1 C.E.C. Part 1.

12.4 freewatt Control Module Installation

- Mount module's enclosure on solid wall or partition after determining location of **freewatt** module. Recommend enclosure be located close to **freewatt PLUS** Boiler, Honda MCHP and HI Module, within reach of supplied, pre-terminated cable.

Figure 12-1 Typical freewatt PLUS Control Module Configuration



- Mounting 2 ft. wide x 4 ft. high sheet of plywood provides mounting surface for control module, relay switches and HHI module. Unit may be mounted up to 20 feet away. Locate enclosure with installation and service accessibility in mind.
- Position control module enclosure above ECR relay switches, place enclosure on relay switch modules with four 1/2" off set nipples, level, and mark mounting holes.
- Start screws, #10, 4 each (field sourced) for keyhole type mounting holes in upper corner(s). Tighten screws down to 1/8" (3mm) from surface.
- Hang enclosure on screws, level enclosure and tighten screws.
- Install four nuts on 1/2" offset nipples to secure enclosure to relay switch modules. Figure 12-1 .

⚠ WARNING

Electric shock hazard. Do not route un-switched line-powered cables or wires through **freewatt PLUS** System. Failure to do so can cause severe personal injury or death.

Recommend no additional electrical connections be made within **freewatt** Control module for line power. If line power is required for condensate pump, separate junction box and receptacle should be provided.

120 VAC dedicated circuit shall conform to NEC and use as minimum 3-conductor, 14 Ga. Cable.

12.5 Wiring Instructions

- Provide and install non-fused disconnect or 120VAC service switch (15 amp recommended) as required by authority having jurisdiction.
- Route 120 VAC power wiring from service switch to boiler's line voltage terminal strip on boiler control panel as outlined in **freewatt PLUS** Boiler Installation, Operation and Maintenance Manual. See Location 8 in Figure 12-2.

12 - ELECTRICAL WIRING & CONNECTIONS

- Route 120 VAC power wiring from service switch to ECR AR822-II and attach to 120 VAC power terminals.
- Route 120 VAC power wiring from junction / switch box to ECR ARM-6P (or AZ-6CP or ARH-3). Wiring can be routed through ½" offset nipple connector and into control module enclosure. Connect 120 VAC power wiring to 12 VDC power supply's pig tail in control module enclosure using wire nuts, attach ground wire to control module enclosure grounding screw located inside bottom of enclosure. Figure 12-3.
- Wire control module to zone relay control and AR822-II following appropriate **freewatt PLUS** System low voltage and line voltage electrical schematics.
- Wire circulators and MCHP's hydronic pump to zone relay control and AR822-II following instructions found in their installation manuals and **freewatt PLUS** System electrical schematics.
- Connect MCHP Coolant Pump's 24VDC power cable to system controller.
- Connect 24 VAC circuits between boiler control and **freewatt** Control Module per applicable electrical schematic.
- Configure jumper on control module circuit board (Figure 12-4) for set-up of hydronic system water heating and space heating zones. Install jumper on DHW pins if zone 1 is connected to aquastat in indirect water tank. Install jumper on HEAT pins if zone 1 is connected to thermostat for space heating. Zone 1 input on the control module must be used for indirect water heater if indirect water heater is used with **freewatt PLUS** System.
- Connect Coolant Pump in HI Module to Control Module J04 connector using furnished coolant pump cable.

12.6 ECR Zone Relay Controls

- Install appropriate ECR Zone Relay Control for temperature control of different heating zones and accommodation of indirect water heater (if used). Refer to Electric Schematics for specific wiring details.
- Use ECR ARM-6P control for **freewatt PLUS** Systems zoned with circulators. ARM-6P control will accommodate up to six zones. Expand ARM-6P with additional ARM controls if more zones are needed.
- Use six-zone ECR AZ-6CP For **freewatt PLUS** System's zoned with valves. AZ-6CP can be expanded up to ten zones with water heating priority with additional AZ control.
- Use three zone ECR ARH-3 control, expanded with additional ARH controls for **freewatt PLUS** Systems with air handlers (hydro-air).
- DHW priority dipswitch on zone control applies only in bypass mode. DHW priority in MCHP mode is determined by firmware setting in freewatt control module accessible via MINT software. Default setting is priority ON when DHW enabled.

Figure 12-2 Boiler 120 VAC Connections (Refer to Electrical Schematic)

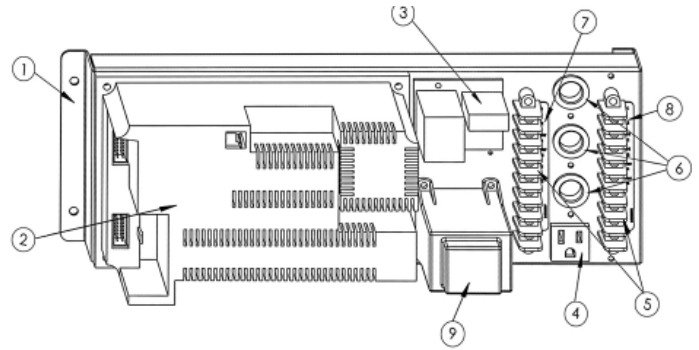

Figure 12-3 Control Module 120 VAC Connections

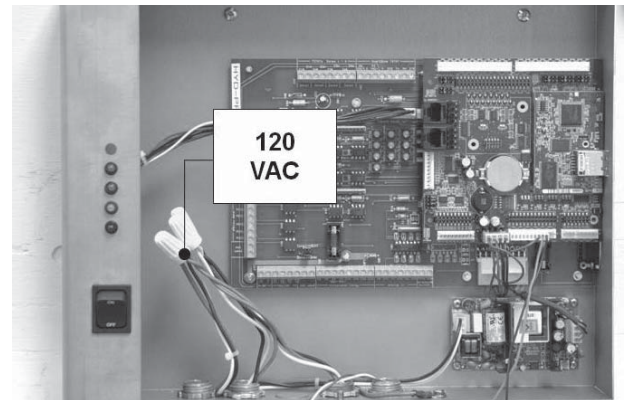
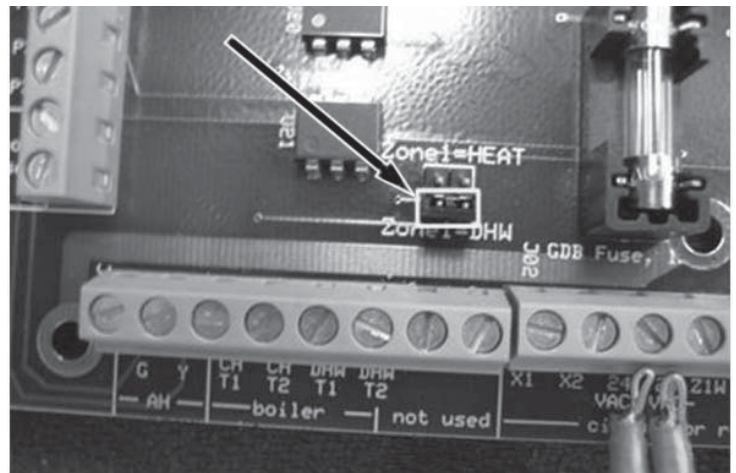

Figure 12-4 Control Module Configuration DHW or CH Jumper



12 - ELECTRICAL WIRING & CONNECTIONS

- External controls with their own 24VAC transformer may be used on zones 3-6. Steering relays can be used through freewatt control module jumpers JPZ3, JPZ4, JPZ5 and JPZ6 (for zones 3-6 respectively). These jumpers are located on the center of the freewatt control board.
 - Control board will use 24V power from external transformer attached to that zone when jumpers are installed across pins.
 - Control board will use 24V power that board receives from connector J17 (1 Amp maximum, 24-30 VAC) if jumper is not installed across pins.

Connect G signal from air handler to zone 4 on **freewatt** control module when using ARH-3 with air handler on smart zone.

Refer to **freewatt PLUS** electrical schematics for wiring instructions.

12.7 Circulator Zoned System - ECR ARM-6P

Dipswitch Settings

Priority Switch:

- Configure ECR ARM-6P for Domestic Hot Water (DHW) Priority when **freewatt PLUS** System includes indirect hot water tank. Place priority switch to ON position. Zone 1 is heating priority. Zone 1 calls for heat all other zones are temporarily deactivated (Priority LED illuminated), priority switch is ON.
- Timer automatically shuts off this feature if priority zone (Zone 1) calls for heat longer than 30 minutes, allowing all zones to operate. Cycle repeats in 30 minutes until priority zone is satisfied.
- Match priority switch setting on ARM-6P to priority setting in **freewatt** control module. Set using laptop and MINT Software tool.

12.8 Valve Zoned System - ECR AZ-6CP

Dipswitch Settings

Set four AZ-6CP control "Option" switches as follows:

- "Zone Valve/Pump Selection Switch" Set to "ON" when using Indirect Water Heater on Zone 1. Switch allows operation of separate water heating "priority" pump of Zone 1, configure for use with indirect water heater having its own "priority" circulator pump and all remaining zones are configured with single "primary" circulating pump and individual zone valves. "Zone/Valve Pump" Switch is in "ON" position for operation of water heating "priority" pump in water heating applications of Zone 1. Zone 1 is central heating zone (no indirect water heater is configured) if "Zone/Valve Pump" switch is "Off", only Zone 1 zone valve terminals are energized. Place "Zone/Valve Pump" Switch in "OFF" position if indirect water heater is not connected as Zone 1.

- IMPORTANT: "Priority Selection Switch" must be in "ON" position when "Zone/Valve Pump" Switch is in "ON" position. Install jumper wire between terminals 3 and 4 of "Zone 1" output of AZ-6CP control when setting "Zone/Valve Pump Selection Switch" in "ON" position,. Jumper not required when using zone valve (no indirect water heater with separate "Priority" circulator) on Zone 1. Wiring see " Low Voltage Wiring: Primary/Secondary Piping with Zone Valve and Domestic Hot Water Priority Circulator".
- Set "Priority Selection Switch" "ON" when using indirect water heater on Zone 1. Use switch to set operational priority to domestic water heating when used with Zone 1. Switch in "ON" position, call for heat by Zone 1 (indirect water heater) activates "Priority" pump connecting to indirect water heater other zones will temporarily deactivate. Temporarily, no space heating supply in response to any space heating thermostats. Priority LED on AZ-6CP will illuminate when priority function is active. After 30 minutes priority is terminated all zones will operate normally. Water heating demand of Zone 1 not satisfied, 30 minute temporary deactivation of all other zones will resume and cycle will repeat. Set "Priority Selection Switch" to "ON" for water heating priority and "OFF" for no water heating priority on Zone 1.]
- "ZR-ZC Selection Switch": Set to "OFF"
- "DPM-2 Selection Switch": Set to "OFF"

12.9 Hydro-Air Zoned System - ECR ARH-3 Settings

Priority Switch:

- freewatt PLUS** System includes indirect hot water tank. Configure ECR ARH-3 for Domestic Hot Water (DHW) Priority. Place Priority Switch to ON position. Water heating zone, is similar to description above for ARM-6P control Priority operation of Zone 1.

NOTICE

Recommended Breaker: 2-pole. 15 Amp breaker.
Flexible metal conduit is required to provide vibration isolation for Honda MCHP.
240 VAC dedicated circuit should conform to NEC and be minimum 4-conductor, 14 AWG flexible metal conduit.

12 - ELECTRICAL WIRING & CONNECTIONS

12.10 Honda MCHP Unit - Line Voltage Connections

- Refer to Honda MCHP Installation Manual – Electrical Connections Section before performing installation in this section.
- Recommend Breaker: 2-pole; 15 Amp breaker.
- Remove cover plate, install blanking plate, connect 240 VAC power cable to terminal block on Honda MCHP unit. Figure 12-5 and 12-10 and Honda MCHP IOM for details.
- Provide and install 240 VAC disconnected switch and junction box onto side of boiler or adjacent wall, route circuit from main service panel to switch and back to **freewatt** Transfer Switch, see electrical schematics. Route 240 VAC circuit from **freewatt** Transfer Switch to Honda MCHP's electrical terminal block per Honda MCHP IOM. Do not attach disconnect switch or junction box onto MCHP unit cabinet. Do not make penetrations in MCHP cabinet.
- Flexible metal conduit is required to provide vibration isolation for Honda MCHP. Use NEC conforming, minimum 4-conductor, 240 VAC dedicated circuit 14 AWG flexible metal conduit.
- Affix Generator warning label provided to main distribution panel where it is clearly seen by any service personnel. Figure 12-9.

12.11 HONDA MCHP Unit - Communication Connections

- Connect Honda MCHP to control module with system-supplied RS 232 communication cable (with attached 9-pin male connector). Plug connector in upper female 9-pin connector on exterior of right side of **freewatt** Control Module. Route MCHP communications cable to Honda MCHP and connect to communication port on Honda MCHP.
- Install strain relief just outside lower compartment. Figure 12-8.

12.12 Smart Zone Thermostat Connections

Refer to instructions supplied with "Zone 2 - Smart Zone" communicating thermostat for installation and operating instructions. Connect thermostat cable to thermostat terminal block, Figure 12-7. Thermostat cable extends from thermostat to control module, routed through low voltage knockout on control module enclosure, Figure 12-6.

- Install thermostat on inside wall away from influences of drafts, hot or cold water pipes, lighting fixtures, televisions, sun rays, or fireplaces. Install "Zone 2 - Smart Zone" thermostat in accordance with guidance provided in Section 2 and 3. (Heating load for Zone 2

Figure 12-5 MCHP Connection Details

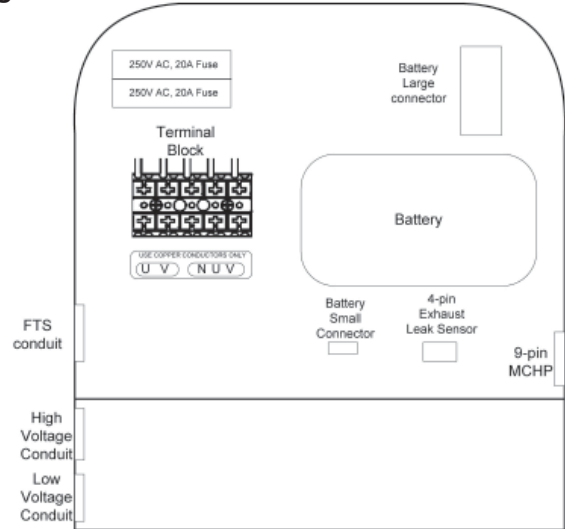

Figure 12-6 T-Stat Connection to Controller

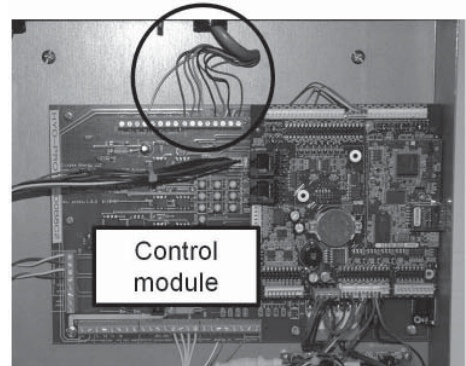

Figure 12-7 Thermostat Connections
RC-1000 baseplate

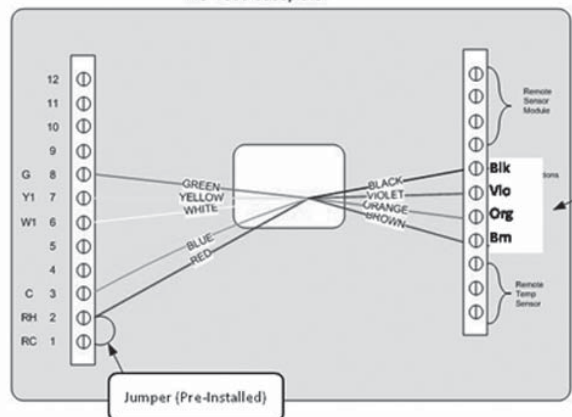

Figure 12-8 MCHP Low Voltage Wiring Strain Relief



12 - ELECTRICAL WIRING & CONNECTIONS

Figure 12-9 Generator Warning Label

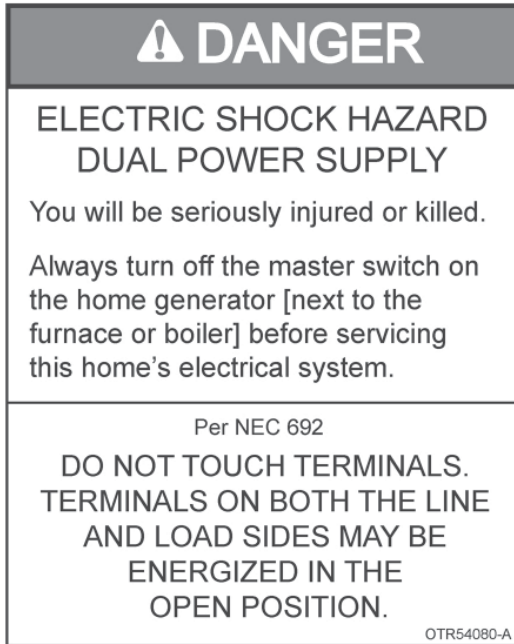
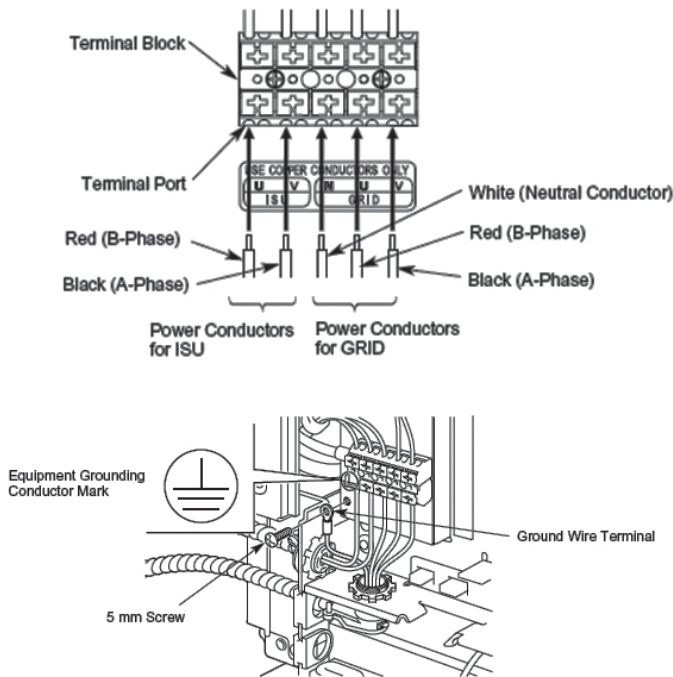

Figure 12-10 MCHP Line Voltage Connections



should not less than about 25% of total for building).

- Connect thermostat cable to thermostat. Use Honeywell Genesis Cable, Model Number 22 AWG 10/C STR CM-CL2 (or equal) for HAI Smart Zone thermostat. Cable is 22 AWG, 10 Conductor, stranded cable meeting UL Standards 13 & 144, NEC Article 725. Refer to **freewatt PLUS** HAI thermostat Installation manual for additional thermostat connection and option details.
- Route cable to control module. Cable will enter control module's enclosure through top knockout opening. Connect to control module's TSAT connections.
- Wire all other compatible zone thermostats (new or existing) and Indirect Water Heater aquastat per instructions provided by manufacturer. First six zones (including DHW if used) connect directly on circuit board of **freewatt** control module. All other zones connect directly to ECR zone relay control.
- When set in the COOL MODE, **freewatt PLUS** thermostat may be used to control air conditioning system. Remove left terminal strip metal jumper between Terminal 1 (RC) and Terminal 2 (RH) on **freewatt PLUS** System configurations with ECR ARM-6P or AZ-6CP zone relay controls and separate cooling 24 VAC transformer (additional to **freewatt PLUS** System transformer) .
- Route air conditioning system 24 VAC source **freewatt PLUS** Thermostat using spare grey wire in **freewatt PLUS** thermostat cable. Use Y wire of thermostat cable to connect directly to Y input of air conditioning system (do not connect Y to **freewatt PLUS** control board). Use external isolation relay for switching cool signal from thermostat, if supplied thermostat does not have terminal for RC.
- Wire thermostat for heating and cooling as indicated in wiring diagrams for **freewatt PLUS** System configurations using ARH-3 zone relay control with air handler.

12.13 Outdoor Temperature Sensor

- Mount supplied Tekmar 070 outdoor sensor on outside exterior wall per sensor manufacturer's instructions, shield from direct sunlight or flow of heat or cooling from other sources. Northern exposure is preferred.
- Route sensor's wires through exterior wall into house and through knockout on top of control module. Do not combine wires of Tekmar Outdoor sensor with **freewatt PLUS** Boiler Outdoor Sensor in single cable, electrical interference will result. See Electrical Schematics.

12.14 Internet Connection

Control module has RJ 45 network connection. Connection found at right of control module's enclosure. Connection point accepts CAT 5e cable.

12 - ELECTRICAL WIRING & CONNECTIONS

12.15 MCHP Battery Installation

Please see the Honda MCHP manual for installation of the MCHP battery.

- Honda MCHP1.2D/MCHP1.2DP unit requires battery to provide power to start up in backup power mode.
- Battery is provided for **freewatt PLUS** System, however to insure proper battery storage and charge level, battery is not packaged with system.
- Battery must be ordered at time of installation from ECR Customer Service by **freewatt** dealer performing installation.
- Original battery provided for each **freewatt PLUS** System will be shipped to installing dealer at no charge.
- Following information must be provided to obtain battery:
 - A. Either Honda MCHP Serial Number or **freewatt PLUS** System Serial Number.
 - B. Your **freewatt** dealer name or dealer number.
 - C. Desired ship-to address.

Call **ECR freewatt** Customer Service toll free at 866-944-6247 to order battery.

NOTICE

IMPORTANT - Honda MCHP unit will not operate without a battery. Use only battery specifically designed for use in Honda MCHP.

13 -COMMISSIONING AND STARTUP

13.1 For System commissioning and startup procedures, refer to literature packet document "Hydronic **freewatt PLUS** System, Model HDJ Commissioning Procedure". You may also refer to the Commissioning Procedure Manual for basic **freewatt PLUS** system sequence of operation.

14 - MAINTENANCE AND CLEANING

WARNING

Disconnect electrical power supply to freewatt PLUS System before attempting any maintenance. Failure to do so can cause electrical shock resulting in personal injury or loss of life.

WARNING

Label all wires prior to disconnection when servicing controls. Wiring errors can cause improper and dangerous operation. Always verify proper operation after servicing.

Review maintenance and cleaning procedures as outlined in Installation, Operation and Maintenance Manuals of boiler and Honda MCHP before proceeding with procedures below.

Regular service and maintenance by qualified service agency must be performed to assure safe, trouble-free operation and maximum efficiency. Service or inspect system at least once every 12 months.

14.1 Beginning of Each Heating Season

Schedule annual service by **freewatt PLUS** dealer or certified service agency, to include:

- Examine boiler as described in annual inspection, service procedures outlined in boiler Installation, Operation and Maintenance Manual. Inspections include, but are not limited to:
 - Heat Exchanger's Flue Passageways
 - Burner
 - Combustion Fan
 - Circulator
 - Electrical Connections
 - Condensate Drain
 - Intake Air and Exhaust Piping
 - Boiler Operation (Safety, Temperature Rise & Burner Ignition)
- Examine control module/HI Module per annual inspection/service procedures outlined below:
 - Control Module: Using laptop computer or PDA check control module's functions. Detailed procedures found in MINT Tool Supplement.
 - Communication/Electrical Connections: Inspect connections to and within Control Module and HI Module. Verify they are secure and connected properly.
 - Bypass Switch: Place CHP Mode Switch in OFF position and operate boiler to verify CHP mode switch is working properly. Place CHP mode switch in ON position after verification is complete.

- Coolant Level: Check coolant level in coolant tank and fill with coolant, if necessary.
- Mixing Valve: Check coolant temperature being delivered by valve while system is operating. Check for leaks and fix, if necessary.
- Pump: Inspect pump and connections. Check for leaks and fix, if necessary.
- Coolant Tubing and Connections: Inspect coolant tubing and connections for leaks and fix, if necessary.
- Brazed Plate Heat Exchanger: Inspect heat exchanger for leaks and fix, if necessary.

Honda MCHP unit requires periodic inspection by certified service professional to maintain acceptable performance and ensure safe operation. Inspection/service procedures are outlined in unit's Installation, Operation and Maintenance Manual. Services are required every 6,000 hours, operating time of unit will directly impact service interval. Inspections include, but are not limited to:

- Starting Ease
- Oil Leakage
- Engine Coolant
- Breather Tube
- Condensate and Condensate Drain
- Air Cleaner Element
- Intake Air and Exhaust Piping
- Ventilation Air Inlet and Outlet
- Coolant Tubing and Connections
- Electrical System and Connections
- Communication System and Connection
- Replace:
 - a.** Engine Oil and Drain Washer.
 - b.** Engine Oil Filter Cartridge.
 - c.** Spark Plugs.
 - d.** Adjust Clearance Between Tappets.

MCHP Owner's Manual outlines specific maintenance intervals (6,000, 12,000, 18,000 & 24,000 hours) and requirements for each interval. Maintenance should be performed by service professional to maintain performance and ensure safe operation of your Honda MCHP.

14 - MAINTENANCE AND CLEANING

14.2 Draining Procedure

It may be necessary to drain system during maintenance operations. Follow procedure below:

NOTICE

Use caution while servicing and disposing of coolant in proper manner. MCHP coolant is 50/50 ethylene glycol solution and is toxic. Glycol is specially formulated with bittering agent to discourage ingestion.

Wait for coolant to cool down if system has been operating. Several hours may be necessary to cool coolant fluid to safe working temperature.

Use precautions while collecting coolant. Coolant may flow at high rate due to pressure in system.

Verify tubing loops are open to prevent any vacuum effect to adversely impact draining operation. If coolant has under 24,000 hours of operation and is clean, reuse when refilling system.

It is recommended to evacuate lines with aid of LOW pressure (under 5 psi) compressed air. Alternatively, hand pump can be used.

1. Shutdown Procedure:

- A. Preferred Method: Set thermostat to OFF by pressing Mode button until display reads OFF. Turn SYSTEM POWER switch to off after shut down cycle of approximately three minutes is completed.
 - B. Emergency Method: Turn SYSTEM POWER and BYPASS switch to OFF. MCHP may overheat and flash error message due to coolant pump turning off.
- 2.** Inspect coolant connections on MCHP unit and integral brass drain valve when coolant achieves a safe working temperature.
 - 3.** Place towel under drain valve.
 - 4.** Verify valve's position is OFF, slowly remove drain cap.
 - 5.** Connect short hose to drain valve and extend to coolant container pan.
 - 6.** Open valve and evacuate coolant from system. Coolant tank's cap may need to be taken off to remove vacuum.

HYDRONIC FREEWATT SYSTEM Model HDJ
 Sequence of Operation/Timeline: *Normal MCHP Mode*

Mechanical Operations

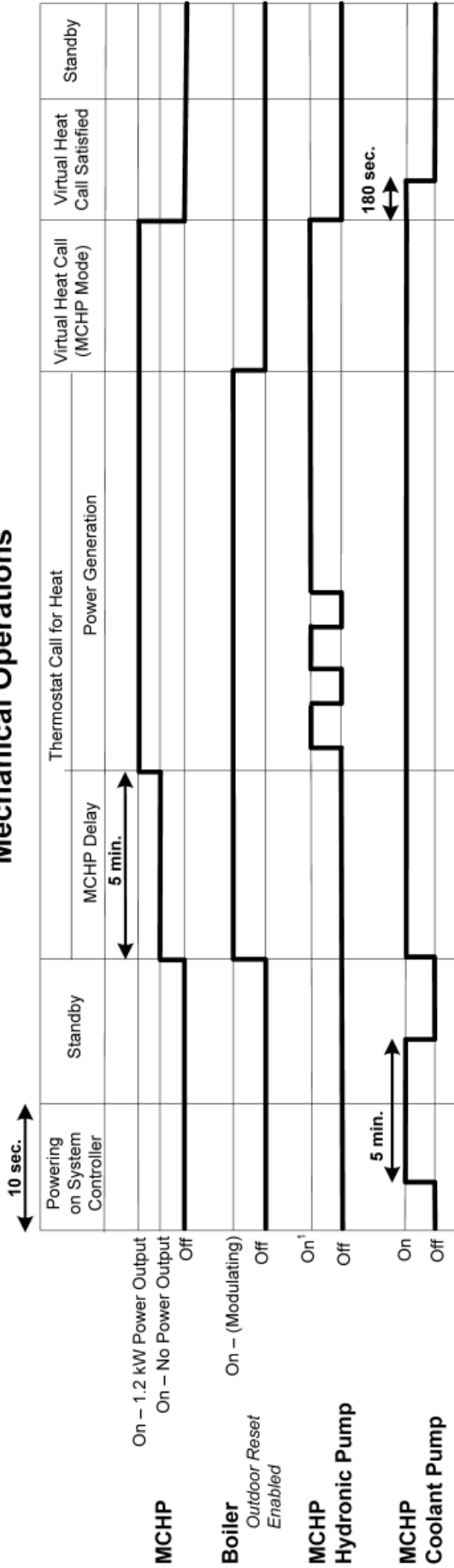

¹The System Controller will cycle the MCHP hydronic pump to maintain MCHP coolant temperatures

LED Display

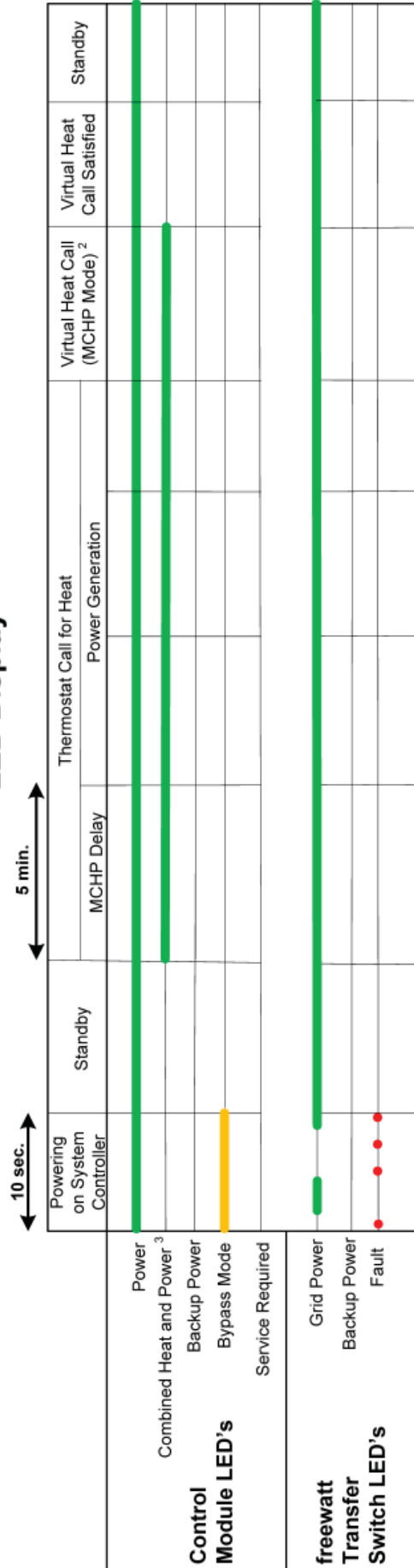

²If every 2 minutes the Zone Controller turns OFF for 2 seconds and back ON, this is a normal function to inspect an expansion module for "Heat Call" activity during a Virtual Space Heating Call or Virtual Domestic Hot Water Call.

³If the CHP LED (Green) is flashing, this is a safety mode of operation that turns off the MCHP based on a spike of the coolant temperature above its recommended range of normal operation. In most cases, this mode will be temporary, but if it persists, please contact your dealer.

HYDRONIC FREEWATT SYSTEM Model HDJ
Sequence of Operation/Timeline: Backup Mode

Mechanical Operations¹

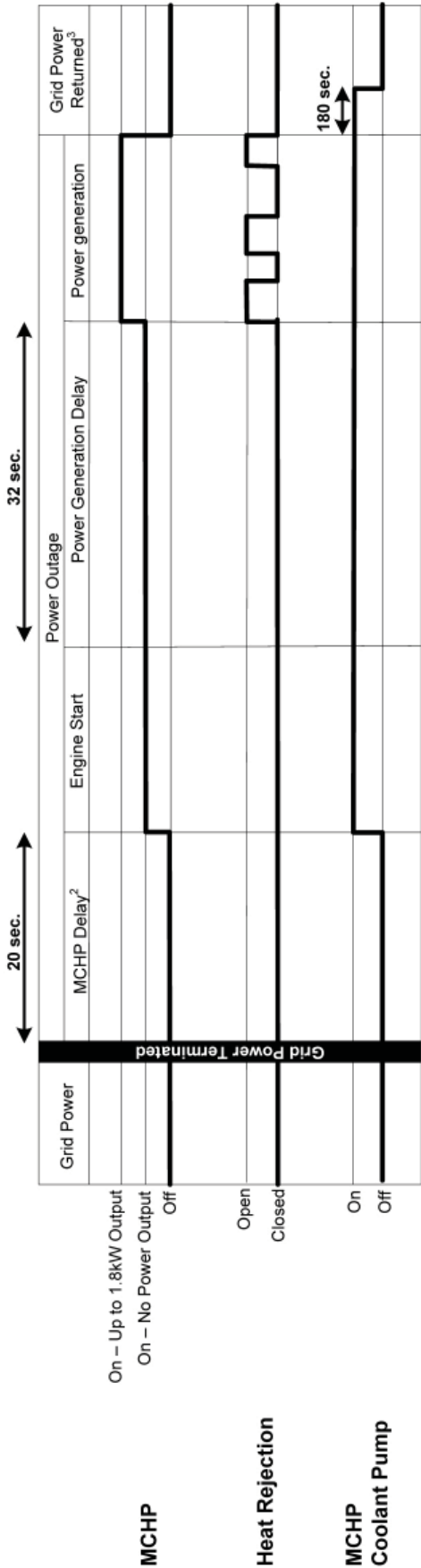

LED Display¹

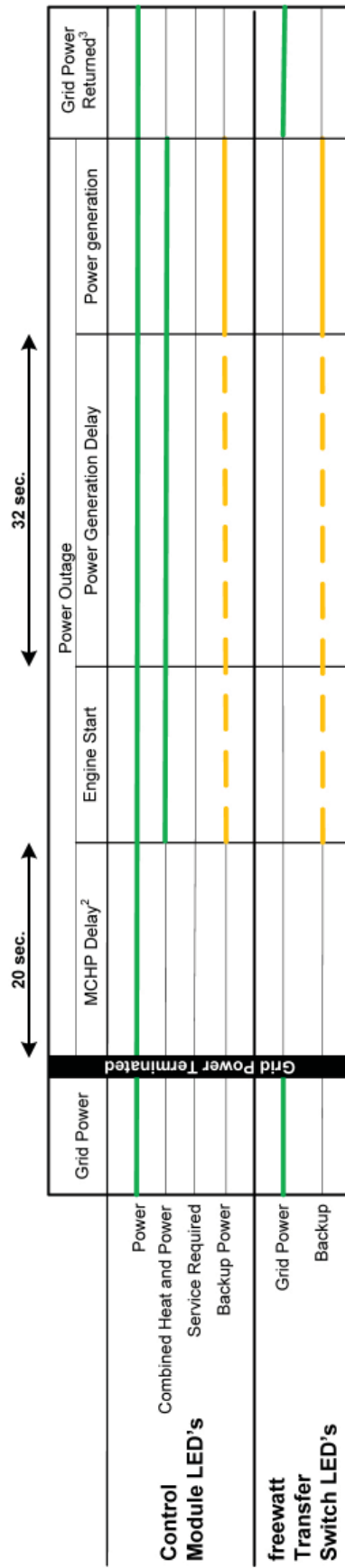

¹ This sequence of operation assumes no thermostat or aquastat heat call. If there is a call for heat, the heat rejection will turn off and MCHP heat will be directed to the hydronic heating loop and appropriate heating zone. Heat calls are handled in the order of priority as shown below:

1. Actual Domestic hot water call
2. Actual Space Heating call
3. Virtual Domestic hot water call
4. Virtual Space Heating Call

In the absence of a heating load, the heat rejection will be turned on for thermal management during backup mode and boost mode.

² If the MCHP is running while grid power is terminated, the MCHP will remain running for 15 seconds (Engine ON; No power Generation) during the MCHP delay.

³ If the MCHP runs for less than 30 minutes in backup mode, the MCHP will run to complete 30 minutes minimum post-run mode. If there is no serviceable call for heat, the heat rejection will be turned on.

15 - DETAILED SEQUENCE OF OPERATION

15.1 MCHP Operation:

- **freewatt PLUS** System is designed to preferentially provide heat to home and indirect water heater by operating MCHP unit.
- Boiler is operated as supplemental heat supply as needed to maintain comfort.
- Preferential operation of MCHP is achieved by allowing MCHP to operate at times when thermostat does not specifically call for heat, but, based on outdoor temperature, continuing need for heat can be established. Homeowner should expect MCHP to “run” longer and more often than boiler, even when thermostat may not indicate call for heat.
- **freewatt PLUS** System designed to maintain close control of building temperature. Variations in room temperature should be less than traditional thermostats with operating temperature dead band.

15.2 freewatt PLUS System Response to Heat Demands:

freewatt PLUS System heating function is activated by call for heat from thermostat or aquastat on indirect water heater. Does not directly respond to electrical power demands in home. Response of **freewatt PLUS** System to heat calls follows:

- Upon demand for heat from any space heating zone, hydronic water flow to zone “radiators” is initiated, MCHP unit is started and boiler operation is enabled. Burner in boiler will fire as necessary to maintain current required hydronic loop temperature as determined by programmed outdoor reset control of boiler. Boiler initially fires at lowest input rate and modulates to higher levels as determined by temperature response of hydronic loop temperature.
 - Smart Zone operation of MCHP unit, initiated by call for heat, will continue beyond specific call for heat from Smart Zone thermostat as long as outdoor temperature sensor indicates general need for heating of building (i.e. outdoor temperature about 55° F). Boiler operation is disabled immediately at end of call for heat from Smart Zone Thermostat. Operation of MCHP unit is terminated only when there is small temperature rise above current set temperature of Smart Zone Thermostat.
 - For other heating zones with room thermostats wired directly to **freewatt** control module, operation of MCHP will continue until initiating zone, or any new heat demand zone is satisfied and **freewatt** control module determines it is not possible to either
 - Operate Smart Zone without exceeding small temperature rise above Smart Zone setpoint or
- Operate domestic water heating zone without causing unacceptably high temperature in MCHP coolant. Boiler burner operation is disabled immediately upon end of call for heat.
 - For zones with room thermostats wired directly to ECR relay control or any ECR expansion relay control, operation of MCHP and boiler burner will terminate with end of heat call (either from initiating zone or any other zone.)
 - Call for heat by Aquastat of indirect water heating tank Zone 1, when Zone 1 is configured for heating of domestic water. Water heating zone pump starts, MCHP operates, boiler burner is enabled to maintain temperature programmed as domestic water heating temperature (**freewatt PLUS** boiler parameter 1 + 33). Boiler burner is disabled and MCHP continues to operate when Aquastat is satisfied, until **freewatt** control module has determined it is not possible to:
 - Operate Smart Zone without exceeding small temperature rise above Smart Zone spacing heating setpoint or
 - Operate domestic water heating zone without causing unacceptable high temperature in MCHP coolant.
 - MCHP coolant temperature is monitored internally and reported to **freewatt** control module. MCHP operation terminates automatically by **freewatt** control module and disabled for period of time ranging from 15 minutes to three hours if MCHP coolant reaches 185°F. Occurs when current target temperature of boiler control is high (about 160° F or above.). Can also occur if boiler temperature boost mode is not disabled as recommended. In either case, **freewatt** control module logic takes into account frequency which 185°F coolant temperature is reached and determines how long to disable operation of MCHP unit. Operational logic limits number of times MCHP is started and stopped in presence of high hydronic loop temperature.
 - Default setup of **freewatt** control module provides 30 minute priority to DHW heating when DHW jumper is in place. Priority action pertains to achieving satisfaction of indirect water heater aquastat (not virtual heat call operation of MCHP unit.) Priority action can be deactivated by using Mint Service Tool.

15 - DETAILED SEQUENCE OF OPERATION

15.3 Achieving Best freewatt PLUS System Performance

Homeowner dollar, carbon dioxide emissions, and energy saving with **freewatt PLUS** is maximized by adjusting operating parameters of boiler and thermostat to achieve maximum preferential operation of MCHP unit (and minimum firing of boiler).

Following steps will help in maximizing benefit of **freewatt PLUS** System.

- Set top target temperature of boiler reset operating temperature control (parameter 4) at lowest possible temperature that will meet heating needs of home on coldest days of year. Recommended maximum top target temperature is 160°F per Commissioning Procedure. Setting top target temperature greater than 160°F will significantly reduce operation of MCHP unit and resulting electric power production. Set target temperature lower if possible.
- Set Aquastat on indirect water heater no greater than 125°F.
- Although it is contrary to modern heating system practice, it is recommended to avoid using setback with **freewatt PLUS** System. Using setback will typically cause Honda MCHP to shut down during setback hours as thermostat will be satisfied, particularly during early stages of setback. This reduces MCHP run hours and power generation significantly, thus reducing electric bill savings and cost effectiveness of **freewatt** system. Coming out of setback requires the **freewatt** boiler to run more to make up additional heat demand. Setting thermostat at a constant temperature and leaving in there will maximize comfort, power generation and electric bill savings. Set it, forget it, and save.
- Select Smart Zone and configure if necessary, so it represents at least 25% of total heat demand of home.
- Set individual zone thermostats so Smart Zone set point is about (1 or 2 degrees) above other zones in home will help maximize production of electricity by **freewatt PLUS** System.
- Set **freewatt PLUS** boiler parameter 11 to zero per Commissioning Procedure. Turns off temperature boost feature of boiler control. If occupants are dissatisfied with response of heating system to thermostat set point adjustments, consider altering outdoor reset curve, using Parameters 4, 5, 6, and 7 before adjusting Parameter 11 to non-zero setting. Keeping parameter 11 at zero is beneficial when there are heating zones that do not have critical heating comfort requirements but will produce nearly constant call for heat. Near constant call for heat can result from heating zone being "under radiated" or heat convectors being closed off. **freewatt PLUS** performs best when all heating zones have appropriate amount of radiation.

16 - TROUBLESHOOTING

WARNING

Fire, explosion or risk of shock hazard may cause severe injury or death. Do not attempt to modify characteristics of this home heating appliance in any way.

16.1 Troubleshooting Tools

- Voltmeter with settings to check: 240 VAC, 120 VAC, 24 VAC and 12 VDC;
- Continuity Tester;
- Contact Thermometer; (Non-Contact Infrared Thermometer)
- Manometer with range of 0 to 20" of water column.
- Laptop Computer Loaded with MINT Software Tool.

16.2 Initial Service Checks

- Verify appropriate 120 VAC and 240 VAC circuit breakers at main service panel are ON. Check outdoor disconnect switch, where applicable, is ON.
- Verify 240 VAC and 120 VAC electric service switches are turned ON.
- Check for 120 VAC (minimum 108 VAC to 132 VAC) to system.
- Check for 240 VAC (minimum 216 VAC to 264 VAC) to Honda MCHP.
- Verify thermostat in Heat Mode.
- Verify thermostat is calling for heat on system control. If not, inspect thermostat connections to ensure proper contact.
- Verify external safety controls are installed and working properly.
- Verify natural gas supply valve is open at gas meter, manual shutoff valves and gas control valve. Gas pressures are maximum of 10" w.c. (natural gas) or 14" w.c. (propane) with no flow or with system operating and minimum of 4" w.c. (natural gas) or 10" w.c. (propane) with gas flowing at maximum firing rate of **freewatt PLUS** boiler (verify during system startup with boiler and Honda MCHP operating simultaneously).
- Check wire connectors at control module, boiler control and Honda MCHP are securely plugged in or connected.
- If any component does not function properly, verify it is correctly installed and wired before replacing it.
- Static electricity discharge can damage control module and boiler control. Touch metal surface to discharge static electricity before touching either control.
- The control module and boiler control cannot be repaired. If either or both controls malfunction, the control unit must be replaced.

- Only trained, experienced service technicians should service control systems. Follow "Sequence of Operation" for normal light off sequence after troubleshooting.
- If two consecutive controls appear to fail or appear defective, control is probably not defective. Another problem may give appearance controls are defective or fail (for example, electrical short burning out transformer).
- Check coolant tubing extending from Honda MCHP to Hydronic Hybrid Integration Module is securely connected and not plugged or damaged.
- Check coolant operating temperature. Using MINT tool, confirm coolant entering MCHP unit is in range of 152-154° F. Check coolant tank in Hydronic Hybrid Integration Module verify filled to above MIN. level line. (Preferred level is just below MAX line.)

16 - TROUBLESHOOTING

WARNING

Electrical shock hazard may cause serious injury or death. Avoid touching live electrical contacts. Service shall be performed by trained, experienced service technician.

WARNING

WHAT TO DO IF YOU SMELL GAS

Do not try to light or start any appliance.

Do not touch any electric switch or use any phone in the building.

Immediately call your gas supplier from a neighbor's phone. Follow gas supplier's instructions.

If you can not contact your gas supplier, call fire department.

WARNING

Fire or explosion hazard. Use only your hand to turn gas control knob. Never use tools. If knob will not turn by hand, don't try to repair it. Force or attempted repair may result in a fire or explosion.

WARNING

Fire or explosion hazard. If overheating occurs or gas supply fails to shut off, do not turn off or disconnect electrical supply to boiler or hydronic hybrid integration module. Shut off gas at location external to appliance.

WARNING

Fire or explosion hazard. Do not use system if any part of gas control system (boiler or MCHP unit) has been underwater. Contact qualified service agency to inspect system and replace any part of control system and any gas control which has been underwater.

16.3 Accessing freewatt PLUS System

Operational Data and Codes

Multiple means of accessing hydronic **freewatt PLUS** System operational data and error codes for purposes of troubleshooting.

- Observe and count number of flashes of red "Service Required" LED on front of **freewatt** control module. See Table 16-1 "Alarm Codes for Service Required LED on **freewatt** control module".
- Observe flash rate of green LED on front of **freewatt** control module labeled "Combined Heat and Power". (See Table 16-2 "Alarms Codes for Combined Heat and Power LED on **freewatt** control Module".
- Observe status (lighted or not) of 10 LEDs on **freewatt** control board in **freewatt** control module. (Remove cover to observe.) See Table 16-3.
- Read boiler operation error code on **freewatt PLUS** boiler electronic front panel per **freewatt PLUS** Boiler Control Manual and Troubleshooting Guide.
- Use MINT software on portable computer connected to **freewatt** control module to display **freewatt PLUS** operating data and error codes for **freewatt PLUS** System and Honda MCHP unit per MINT software Manual.
- Remove metal cover of control panel on MCHP (located upper left side of unit) and read error codes per Honda MCHP Installation and Operation Manual.
- **freewatt PLUS** systems operate with RC-1000 HAI thermostat, note color of thermostat display (red for fault/alarm condition) and read **freewatt** control module error message display. Error messages same as "Alarm Codes for System Service LED on **freewatt** Control Module".
- Call ECR **freewatt PLUS** Technical Support representative.

16 - TROUBLESHOOTING

16.4 General Troubleshooting

If	And	Check or repair
No Control module or HI Module operation		120 VAC electrical connections Blown fuse on freewatt control module circuit board
No boiler operation		Thermostat settings Check Boiler per freewatt PLUS Boiler Control Manual and Troubleshooting Guide
Honda MCHP overheats		<ul style="list-style-type: none"> • Coolant Pump functioning Properly • Circulators Functioning Properly • Air in Coolant Line • Coolant Line Blocked • Coolant lines piped correctly into Honda MCHP • Mixing valve setting
No power to thermostat	Display is blank	Check Control Module Connection Fuse in thermostat 24VAC Fuse in freewatt control module or Faulty wire connection
No Honda MCHP operation		See MCHP Manual

Hydronic **freewatt PLUS** System consists of eight major components:

- Boiler,
- **freewatt** Control Module,
- Hydronic **freewatt PLUS** Hybrid Integration (HI) Module,
- Honda MCHP,
- **freewatt** HAI Thermostat,
- **freewatt** Transfer Switch,
- Load Balancing Transformer and
- APC Universal Transfer Switch

Each major component has its own installation and service manual outlining troubleshooting information regarding individual component.

Make corrective action. Turn off power and restart system to clear error conditions.

Use BYPASS MODE, (CHP MODE OFF) to sustain heating operation while resolving **freewatt** control module or MCHP unit errors or malfunctions.

16 - TROUBLESHOOTING

Table 16-1 Alarm Codes for Service Required LED on freewatt Control Module

ERROR CODE	INDICATES	CHECK OR REPAIR
1	THERMOSTAT COMMUNICATIONS ERROR	1. CHP MODE SWITCH IN ON POSITION 2. CABLES AND CONNECTIONS BETWEEN THE THERMOSTAT AND THE HI MODULE 3. LOWER FURNACE ACCESS PANEL INSTALLED 4. IMPROPERLY PROGRAMMED THERMOSTAT
2	OUTDOOR SENSOR ERROR	1. CHECK OUTDOOR SENSOR AND CONNECTION OR INTERNAL 20k OHM DEFAULT RESISTOR
3	MCHP COMMUNICATIONS ERROR	1. RESET SYSTEM POWER 2. POWER TO MCHP 3. CABLES AND CONNECTIONS BETWEEN HONDA MCHP AND HI MODULE
4	MCHP DEVICE ERROR (MCHP ASSERTING "FAILURE" STATUS, IE. A HARD ERROR)	CHECK HONDA MCHP DIAGNOSTICS
5	MCHP DEVICE WARNING (MCHP ASSERTING "WARNING" STATUS, IE. A SOFT ERROR)	
6	freewatt PLUS FLASH PARAMETER INTEGRITY CHECK ERROR	SERVICE REQUIRED
7	SYSTEM POWER SWITCH OFF, UNABLE TO ENTER BACKUP MODE (NOTE: NOT DEFINED IN HYDRONIC SYSTEM)	
8	MCHP PLACED IN LOCKED MODE BY SERVICE TECH, PREVENTS MCHP OPERATION	
9	RESERVED FOR FUTURE USE	
10	ERROR CODE 10 NOT USED	
11	LOW DWELLING TEMPERATURE. BOILER DOWN OR THERMOSTAT "OFF" BY MISTAKE	
12	RESERVED FOR FUTURE USE	
13	VIRTUAL WATCHDOG TIME-OUT. AN UNEXPECTED FIRMWARE EXECUTION ERROR OCCURRED.	REPLACE CONTROLLER MODULE
14	EXHAUST GAS LEAK SENSOR FAILURE, HONDA MCHP ERROR 39.0 (EX_SENS_FAIL)	
15	EXHAUST GAS LEAK SENSOR POWER FAILURE, HONDA MCHP ERROR 39.1,(EX_SENS_POWER_FAIL)	
16	EXHAUST GAS LEAK SENSOR ALARM, COMBUSTION GAS DETECTED, HONDA MCHP ERROR 10.1, (EX_LEAKAGE_FAIL)	
17	NO DC POWER SUPPLY VOLTAGE DETECTED IN BACKUP MODE. (LOAD_PWR_FAULT)	INDICATES A FAULT IN 120V LOAD CIRCUIT
18	DETECTED A freewatt PLUS TRANSFER SWITCH COMMUNICATIONS FAILURE	Check fTS communications cable
19	DETECTED A freewatt PLUS TRANSFER SWITCH DEVICE ERROR	see freewatt transfer switch IOM
20	ERROR CODE 20 NOT USED	
21	DETECTED A freewatt PLUS TRANSFER SWITCH STATE ERROR	see freewatt transfer switch IOM
22	RESERVED FOR FUTURE USE	
23	DETECTED A freewatt PLUS TRANSFER SWITCH CONTACTOR #1 ERROR	see freewatt transfer switch IOM
24	DETECTED A freewatt PLUS TRANSFER SWITCH CONTACTOR #2 ERROR	see freewatt transfer switch IOM
25	EXHAUST GAS LEAK SENSOR TEST BUTTON PRESSED	
26	VOLTAGE DETECTED ON THE freewatt PLUS TRANSFER SWITCH ISLAND NODES (I1 OR I2) IN BACKUP POWER MODE	see freewatt transfer switch IOM
27	RESERVED FOR FUTURE USE	
28	MISSING L1 OR L2 OF AC POWER (fTS_AC_FAULT)	BLOWN FUSE, FAULTY WIRING, UTILITY FAULT
29-98	RESERVED FOR FUTURE USE	
99	VIRTUAL WATCHDOG TIME-OUT OCCURRED 5 OR MORE TIMES. MULTIPLE UNEXPECTED FIRMWARE EXECUTION ERRORS OCCURRED.	REPLACE CONTROL MODULE

16 - TROUBLESHOOTING

Table 16-2	
Alarms Codes for Combined Heat and Power LED on freewatt Control Module	
Combined Heat Power LED Status	Condition
Rapid Flash (~5 per second)	MCHP operation suspended on detection of high coolant temperature
Steady ON	Normal MCHP Operation

16.5 MCHP Suspended Mode

MCHP operation will be suspended if there is detection of high coolant temperature, indicated by rapidly flashing Combined Heat and Power LED. MCHP Suspend Mode prevents MCHP unit from cycling in overheat situation in which it cannot run. Condition may be due to boiler temperature set higher than recommended, improperly commissioned system, or high aquastat setting on indirect hot water tank. Perform following tasks if suspend condition is encountered.

- **Check boiler parameters.** Hydronic **freewatt** system has maximum recommended design water temperature of 160° F. Suspend mode will occur and effect overall MCHP runtime and power generation, if boiler water temperature is higher than 160° F.
- **Check aquastat on indirect water tank is set no higher than 125° F.** MCHP may not run while boiler is satisfying indirect hot water tank, if aquastat must be set higher for hot water recovery.
- **Ensure flow is present** in coolant loop and hydronic loop (check for working pumps).
- **Ensure system is properly commissioned** per Hydronic Commissioning Procedure.

16.6 Control Board LED Interpretation

- Observe green LEDs on control board by removing cover of **freewatt** Control Module.
- Control Board LEDs are valid only in Combined Heat and Power Mode (CHP Mode switch "ON"). They are not used when system is in Bypass Mode (CHP Mode switch "OFF").
- Do not use Control Board LEDs as indicator of system status when in Bypass Mode.

Table 16-3		
Controller Board LED's indicate:		
	LED ON	LED OFF
Z1	Zone 1 circulator ON	Zone 1 circulator OFF
Z2	Zone 2 circulator ON	Zone 2 circulator OFF
Z3	Zone 3 circulator ON	Zone 3 circulator OFF
Z4	Zone 4 circulator ON	Zone 4 circulator OFF
Z5	Zone 5 circulator ON	Zone 5 circulator OFF
Z6	Zone 6 circulator ON	Zone 6 circulator OFF
MCHP ENB	MCHP enabled	MCHP disabled
X1X2	Relay XX end switch relay closed	Relay XX end switch relay open
MyEND	freewatt Control Module closed either DHW or CH input to boiler, requesting boiler operation	freewatt Control Module not requesting boiler operation
PUMP1	24 VDC coolant pump in HI Module energized	24 VDC coolant pump not energized
PUMP2	120 VAC Hydronic circulator connected to HI Module energized through external relay switch	120 VAC Hydronic circulator not energized
PUMP3	Not used	Not used

NOTE: One or more zone circulators may be activated without specific call for heat by room thermostats or DHW aquastat consequence of control logic anticipating heat demand and attempting to maximize MCHP run time.

16 - TROUBLESHOOTING

16.6 freewatt PLUS System Fuses

⚠ WARNING

Do not jumper fuse. Replace specified as listed. Failure to comply could result in severe personal injury, or death.

⚠ WARNING

Label all wiring prior to disconnection when servicing controls. Wiring errors can cause improper and dangerous operation. Disconnect power to system before servicing. Failure to comply could result in severe personal injury or death.

NOTICE

Check control module fuses before replacing control module or other major component (pump, motor, etc.). Blown fuse may prevent system control module or other components from operating.

NOTICE

On board fuses are not available from ECR International. Service technicians should provide fuses for **freewatt** PLUS service from local suppliers.

Refer to Table 16-4.

Table 16-4 freewatt PLUS System Fuses						
Location	QTY	Amp	Voltage	Spares	Shape	Size
Control Module (Control board, GDB Fuse)	1	2	250	0	Cylinder	5mm X 20mm
Boiler (Control Board F1, Lower RH Corner)	1	5	250	2	Cylinder	5mm X 20mm
Boiler (Control Board F3, Middle Right Side)	1	4	250	2	Cylinder	5mm X 20mm
MCHP*	1	1	650DC	0	Cylinder	6.35mm x 32mm
MCHP *	2	20	600AC	0	Cylinder	10.3mm x 38.1mm
APC UTS6H Control Board (Use Littlefuse KLKR15 or equiv.)	6	15	600AC	0	Cylinder	10.3mm x 38.1mm
* Refer to MCHP Shop Manual						

17 - PIPING AND WIRING SCHEMATICS

17-1 Piping Schematic Symbols

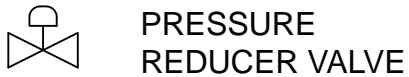
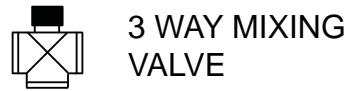
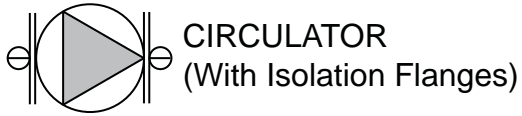

17 - PIPING AND WIRING SCHEMATICS

17-2 Primary/Secondary Piping With Zone Valves and Domestic Hot Water Priority Circulator

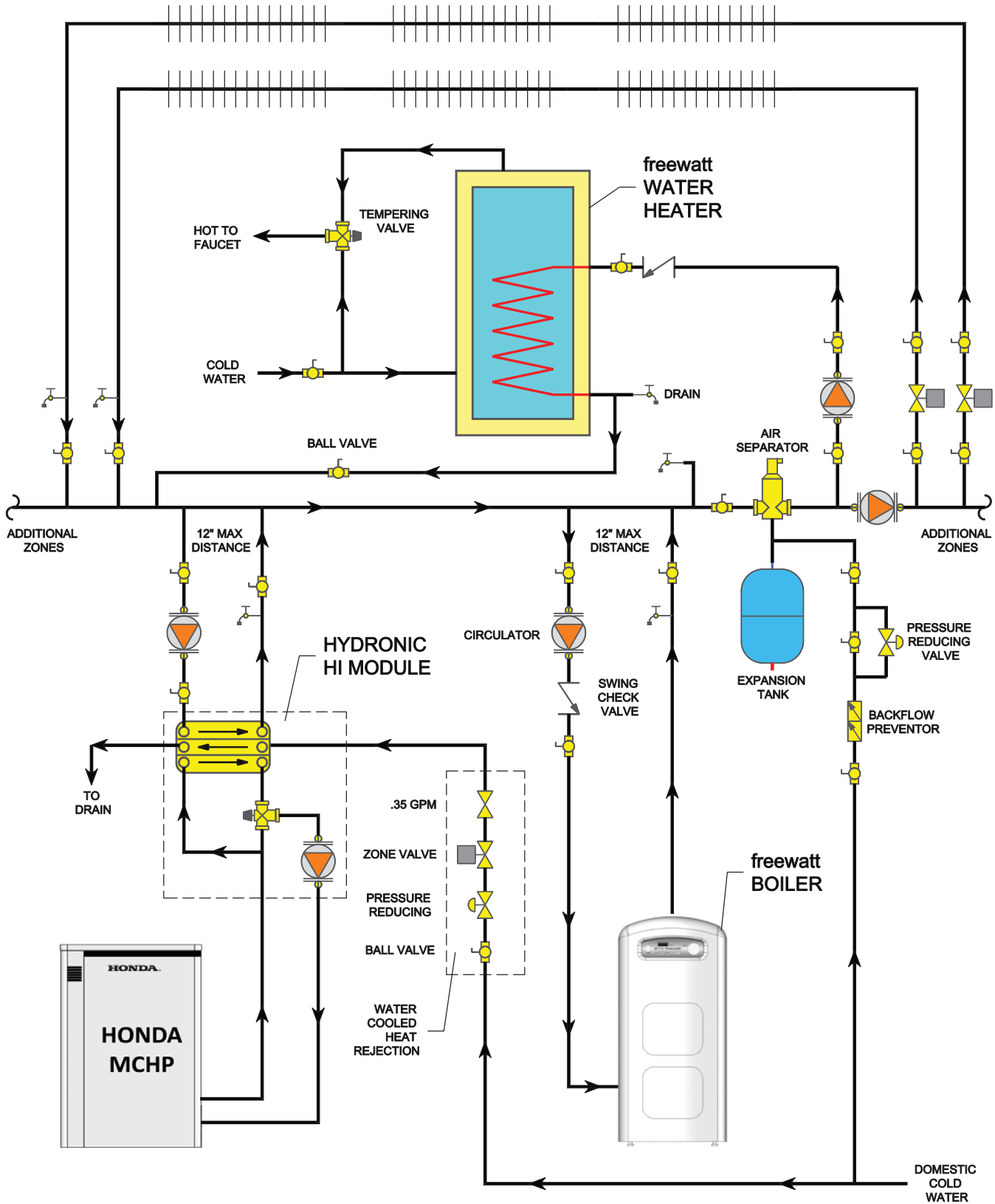

17 - PIPING AND WIRING SCHEMATICS

17-3 Primary/Secondary Piping With Circulators and Domestic Hot Water Priority Circulator

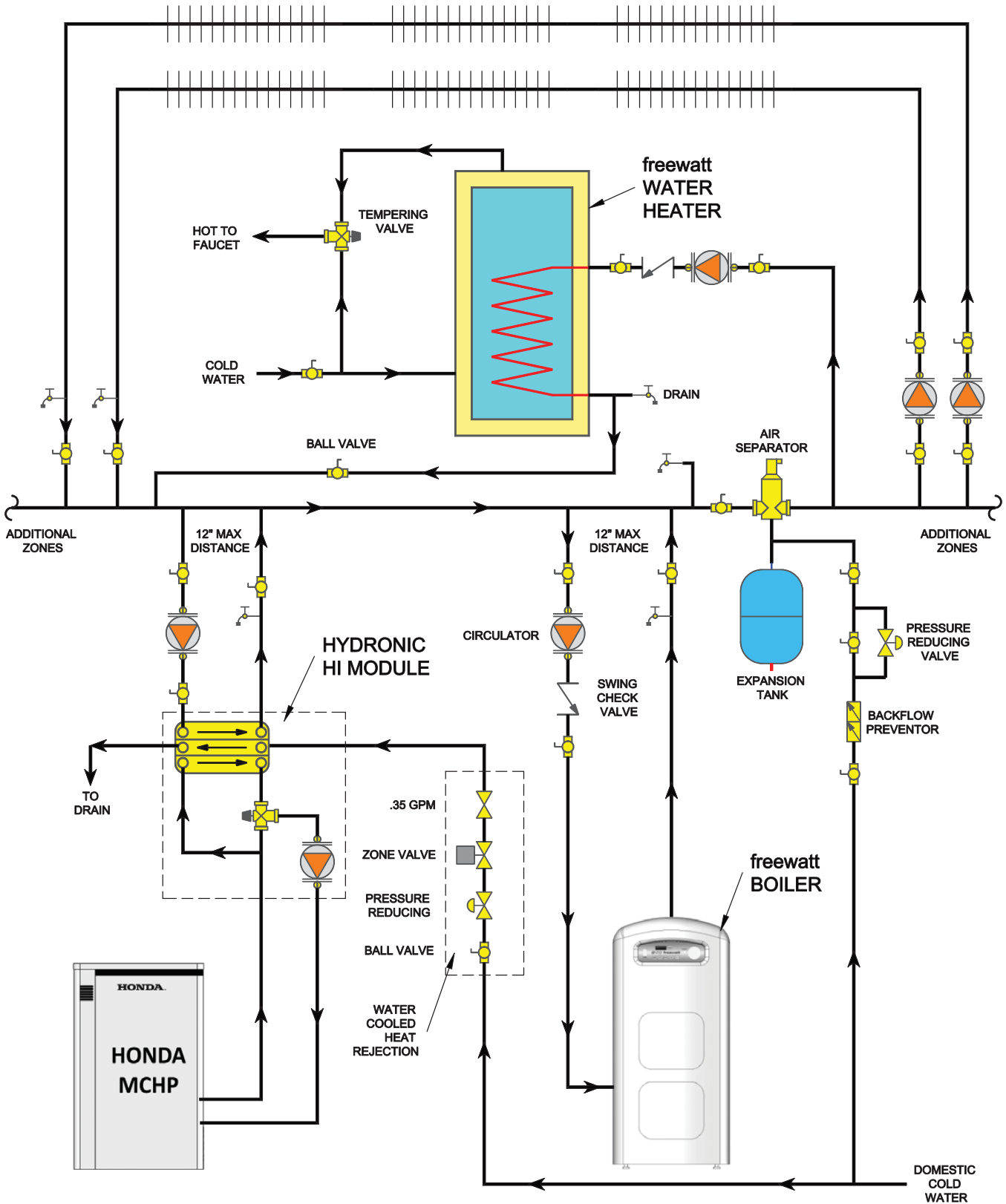

17 - PIPING AND WIRING SCHEMATICS

17-4 Primary/Secondary Piping With Hydro-Air Handler and Domestic Hot Water Priority Circulator

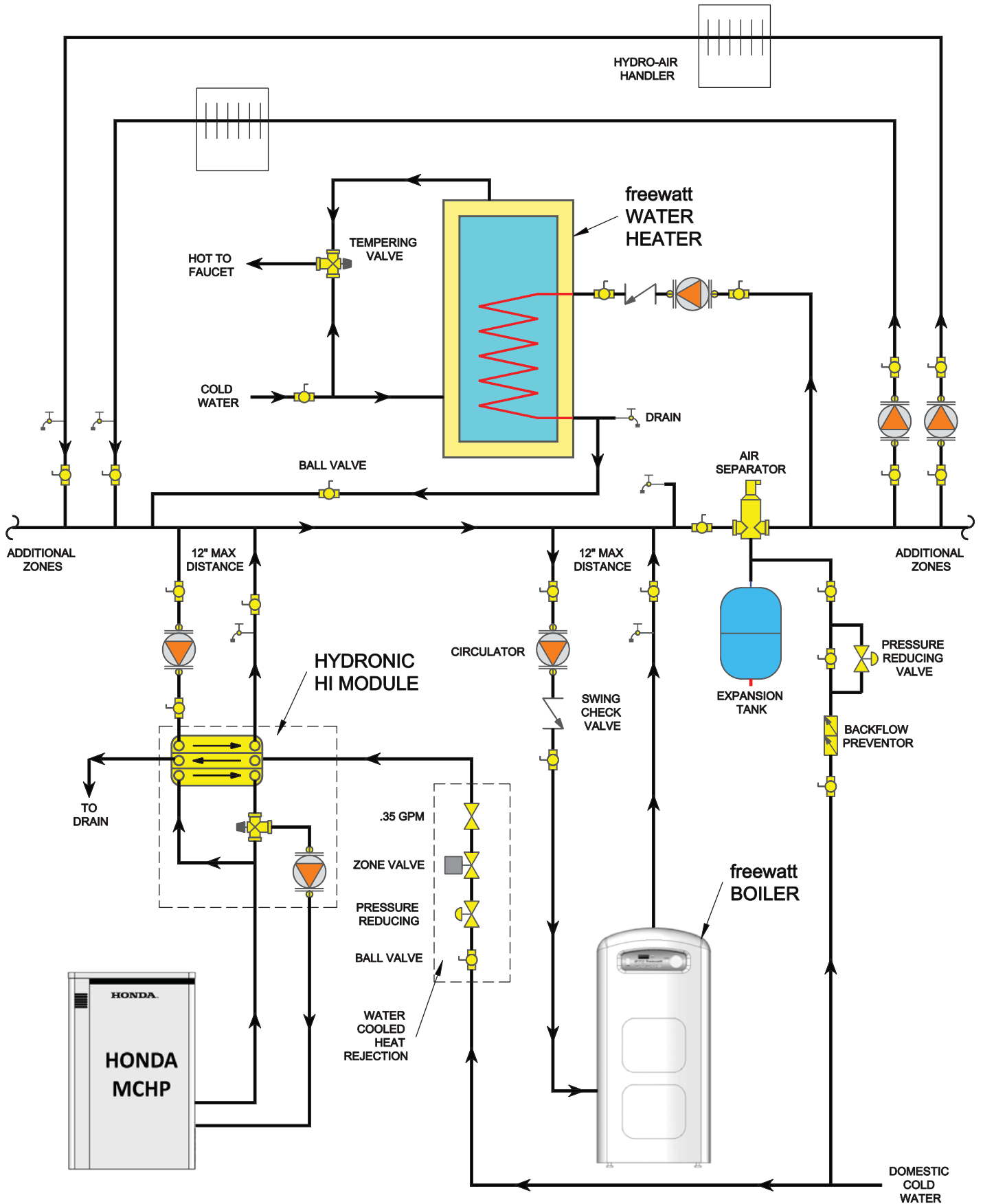

17 - PIPING AND WIRING SCHEMATICS

17-5 HDJ - 240 VAC Wiring Only

Electrical Schematic 240 VAC WIRING ONLY

Hydronic freewatt Plus System, HDJ

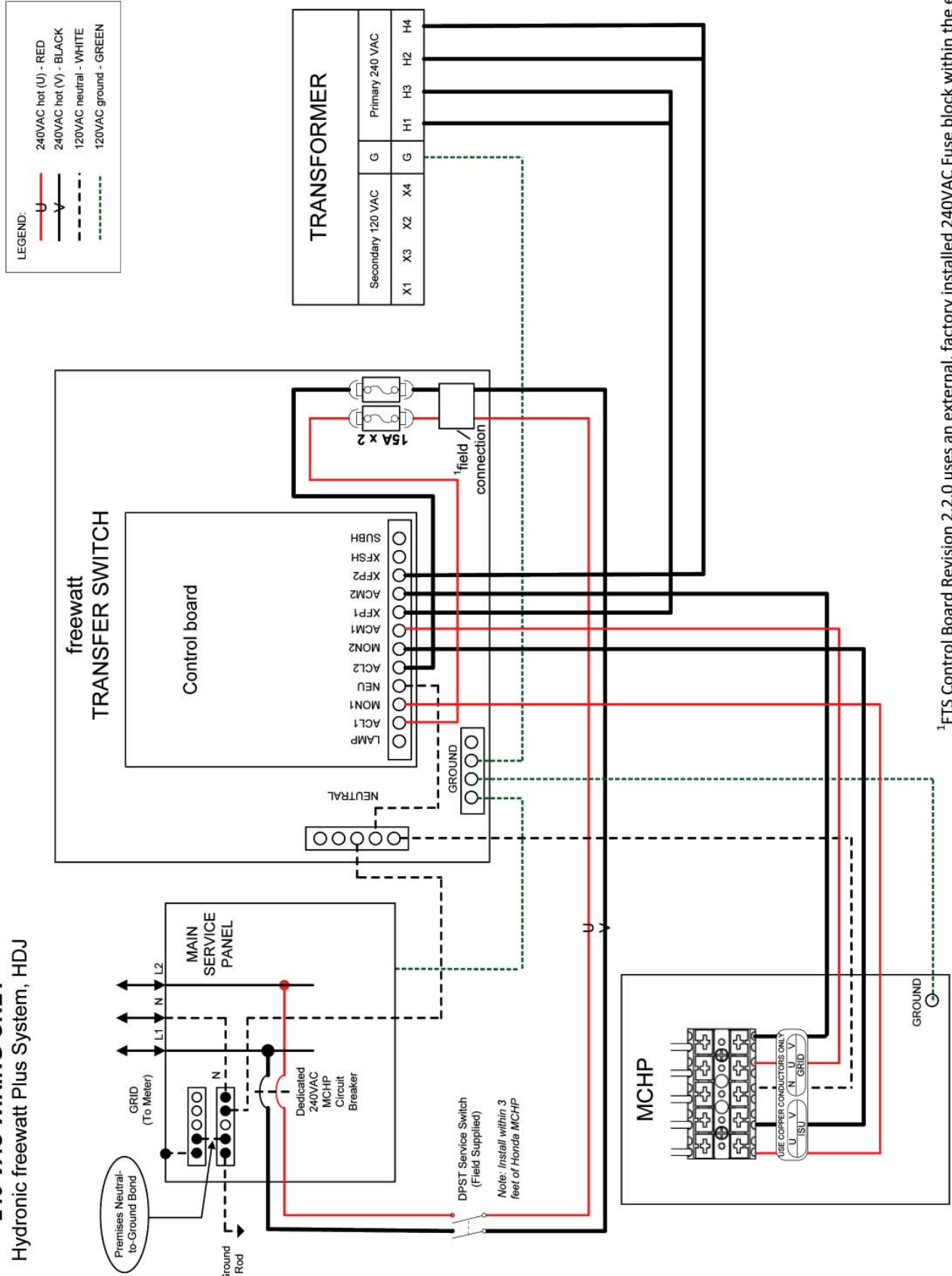

¹FTS Control Board Revision 2.2.0 uses an external, factory installed 240VAC Fuse block within the enclosure.
 FTS Control Board Revision 2.2.1 does not use an external fuse block, Wiring from the main service panel connects directly to the screw terminals on the board

17 - PIPING AND WIRING SCHEMATICS

17-6 HDJ - 120 VAC Wiring Only

Electrical Schematic 120 VAC WIRING ONLY

Hydronic freewatt Plus System, HDJ

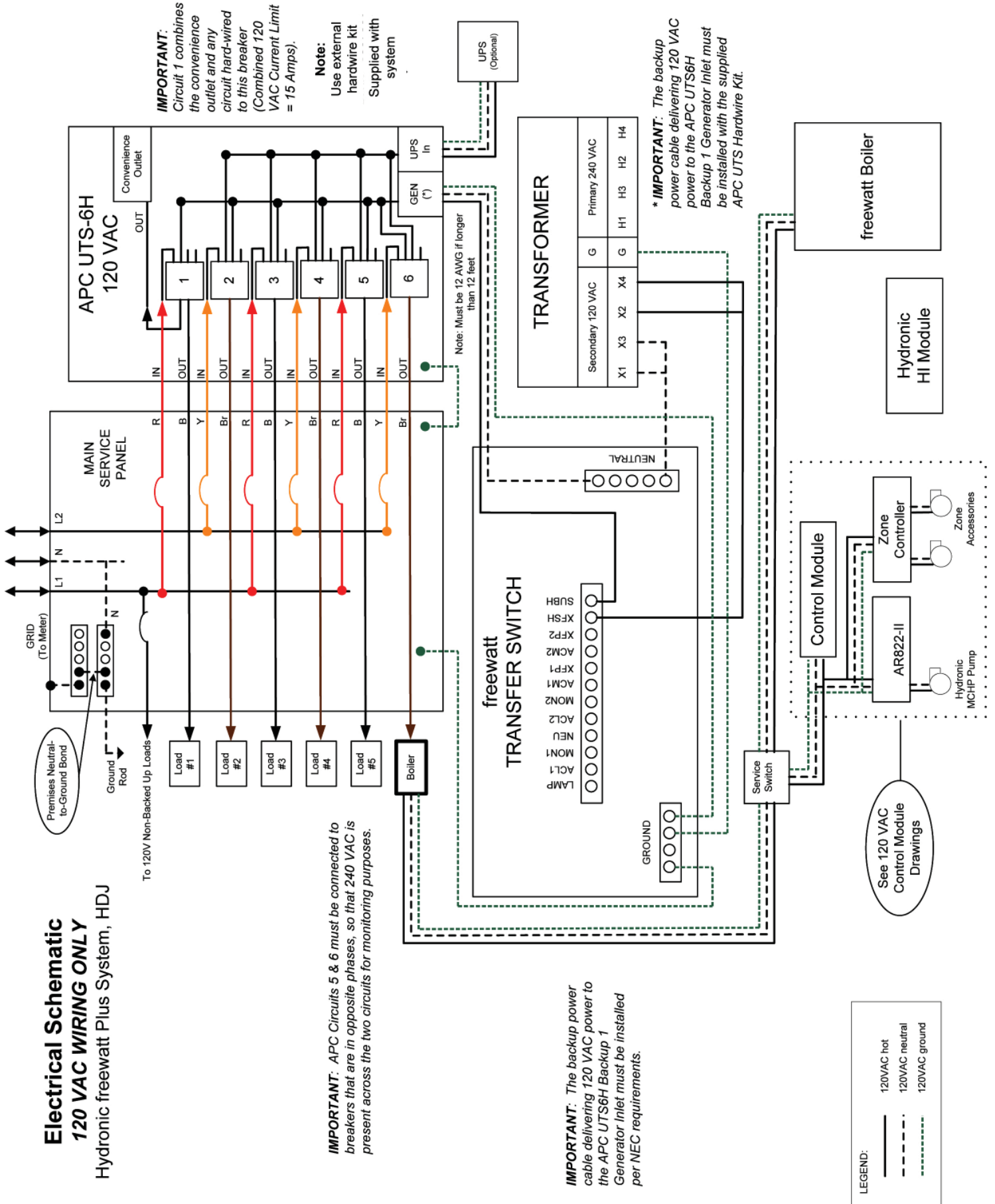

17 - PIPING AND WIRING SCHEMATICS

17-10 HDJ - Low Voltage Wiring Only

Electrical Schematic LOW VOLTAGE WIRING ONLY

Hydronic freewatt Plus System, HDJ

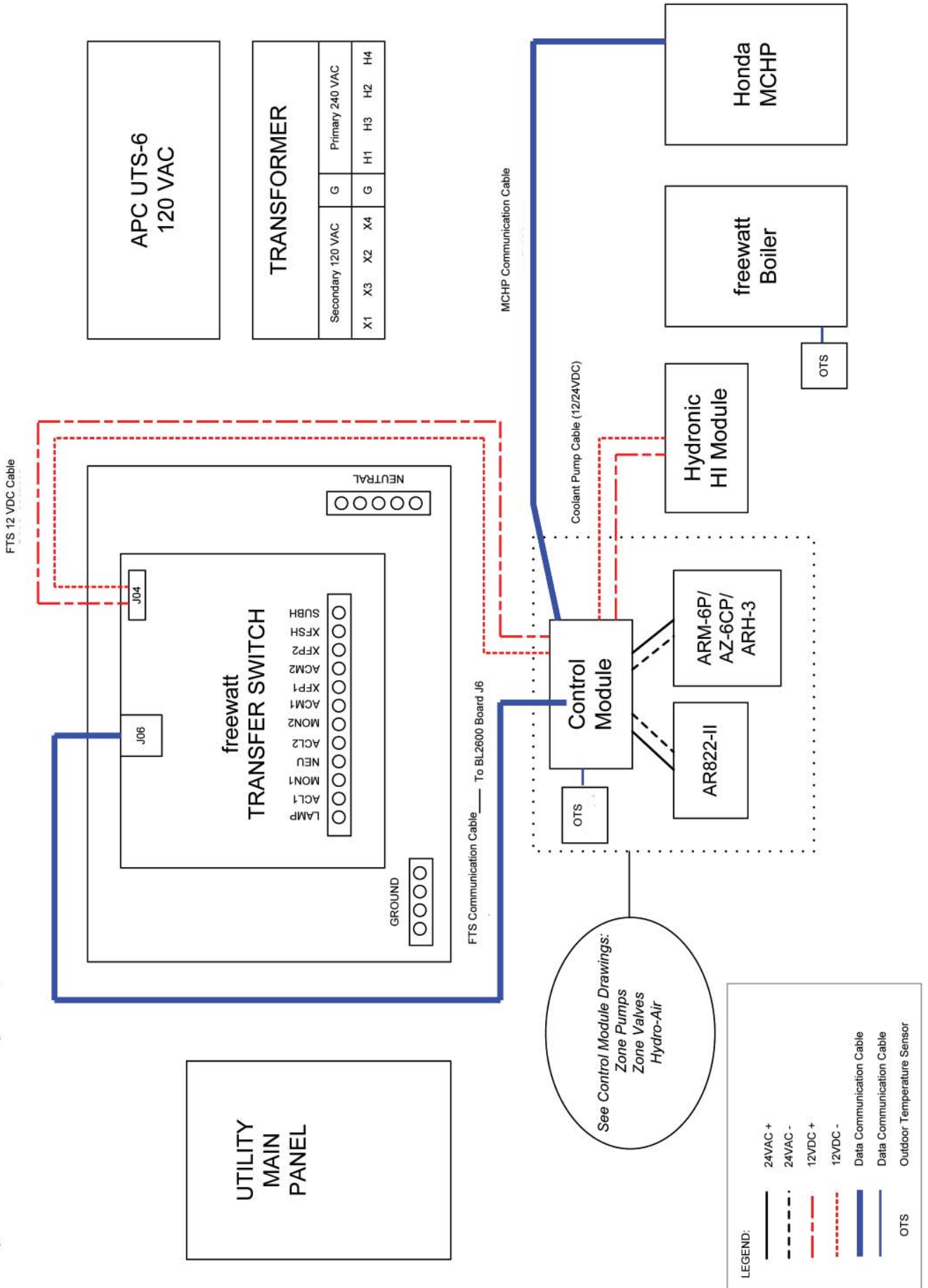

17 - PIPING AND WIRING SCHEMATICS

17-11 HDJ Low Voltage Only Wiring - Control Module and Zone Pumps

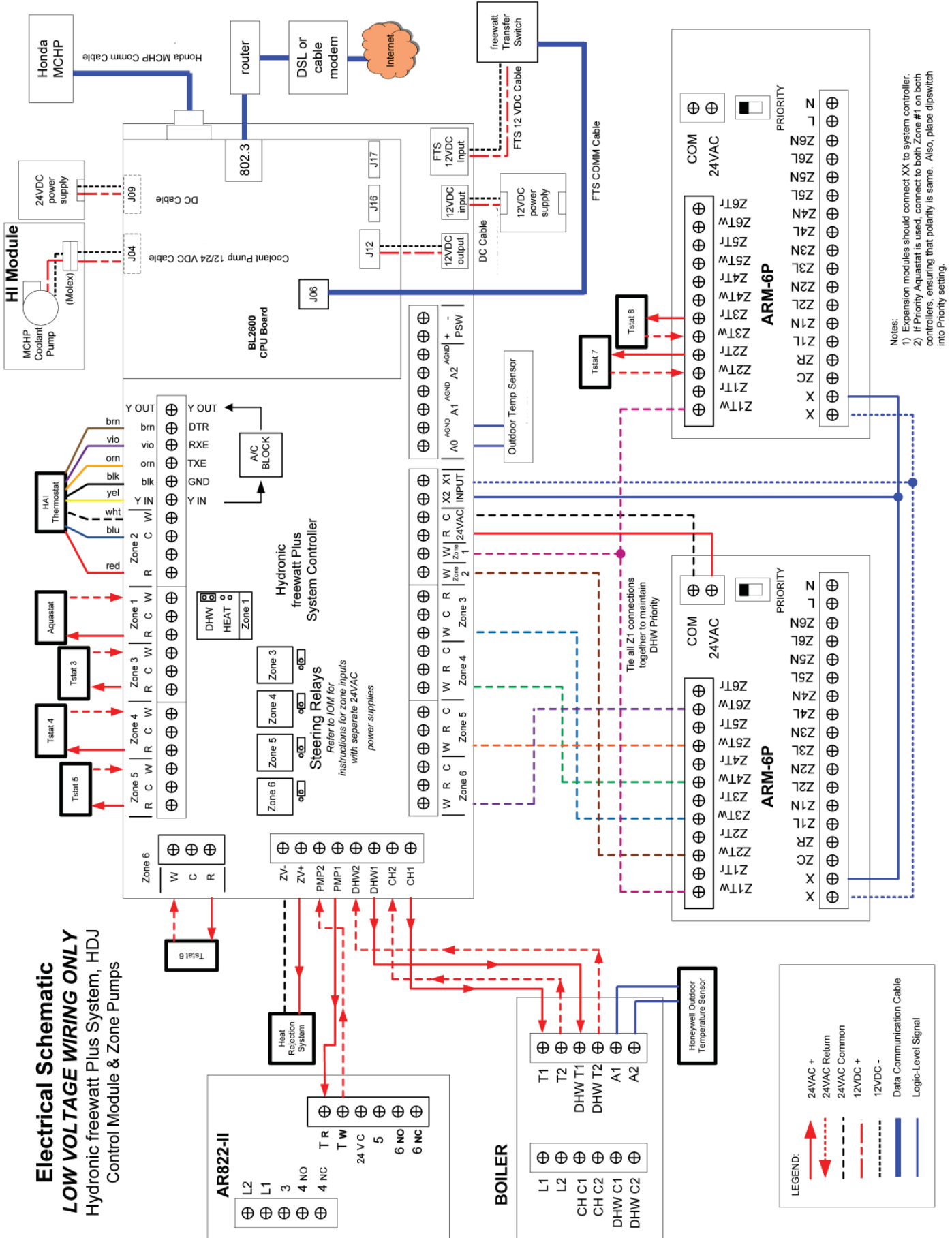

17 - PIPING AND WIRING SCHEMATICS

17-12 HDJ Low Voltage Only Wiring - Control Module & Zone Valves

Electrical Schematic LOW VOLTAGE WIRING ONLY Hydronic freewatt Plus System, HDJ Control Module & Zone Valves

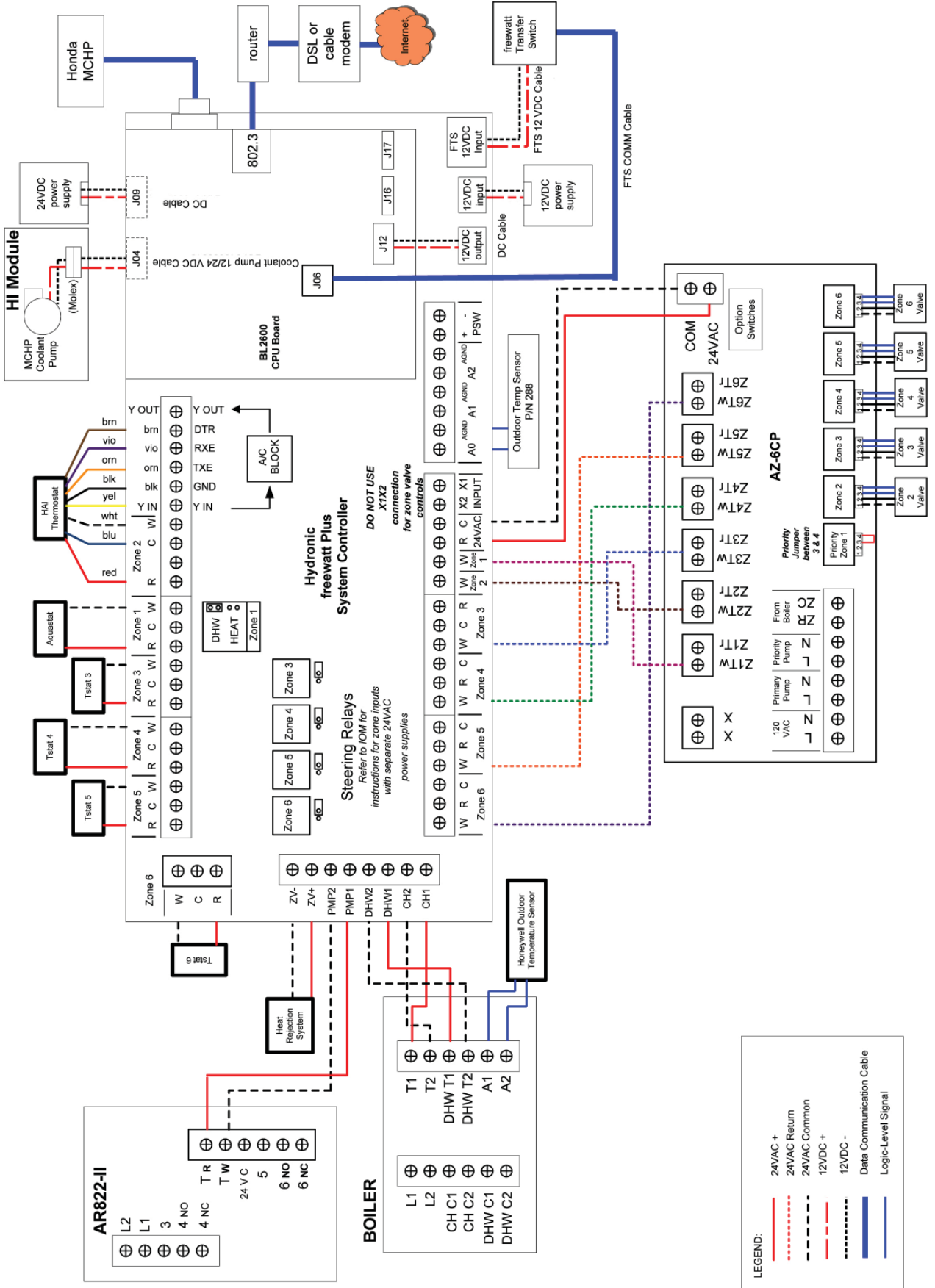

17 - PIPING AND WIRING SCHEMATICS

17-13 HDJ Low Voltage Only Wiring - Control Module & Zone Valves with Expansion Zones

Electrical Schematic LOW VOLTAGE WIRING ONLY Hydronic freewatt Plus System, HDJ Control Module & Zone Valves With Expansion Zones

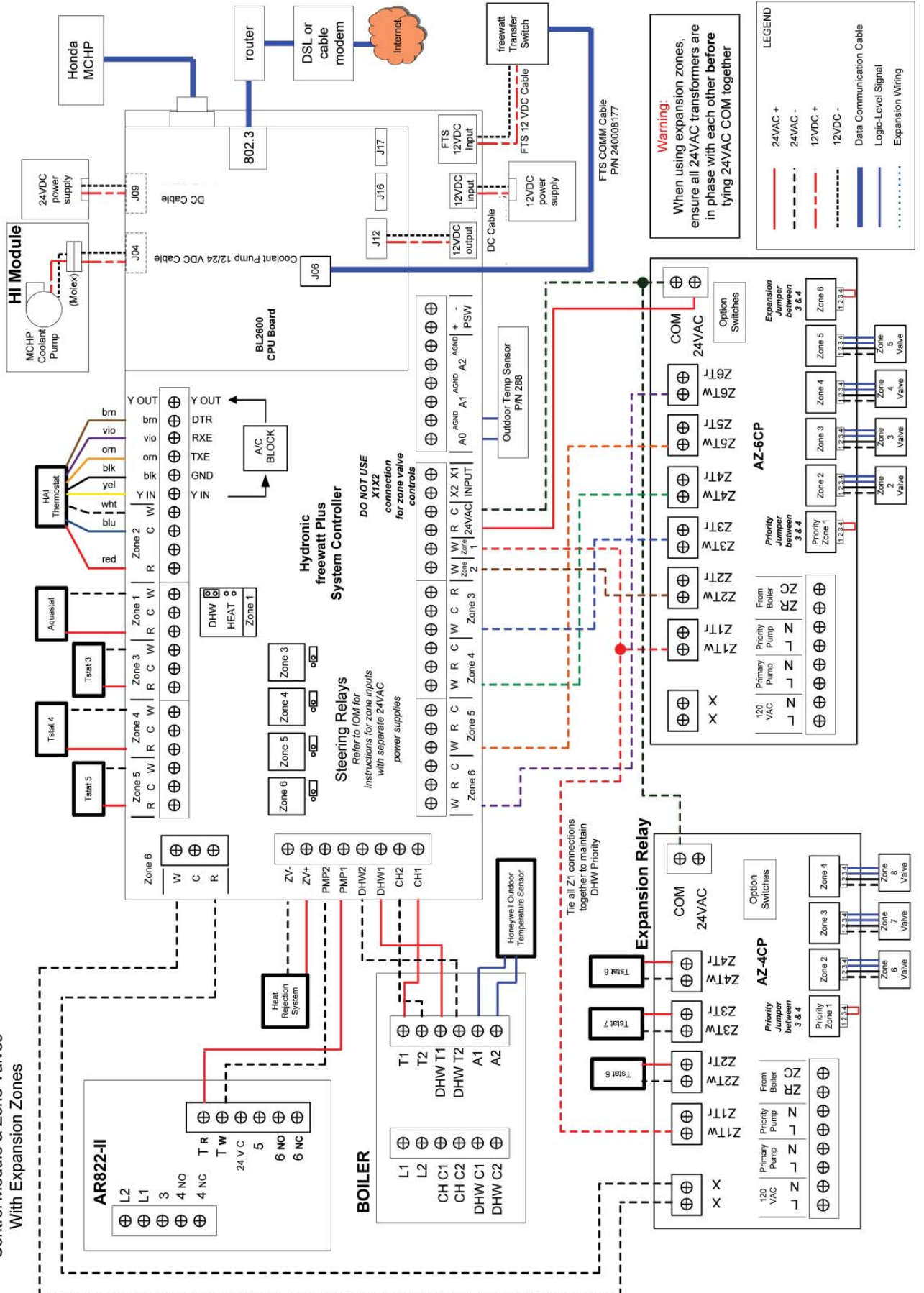

17 - PIPING AND WIRING SCHEMATICS

17-14 MCHP Low Voltage Wiring

Electrical Schematic MCHP LOW VOLTAGE WIRING Hydronic freewatt Plus System, HDJ

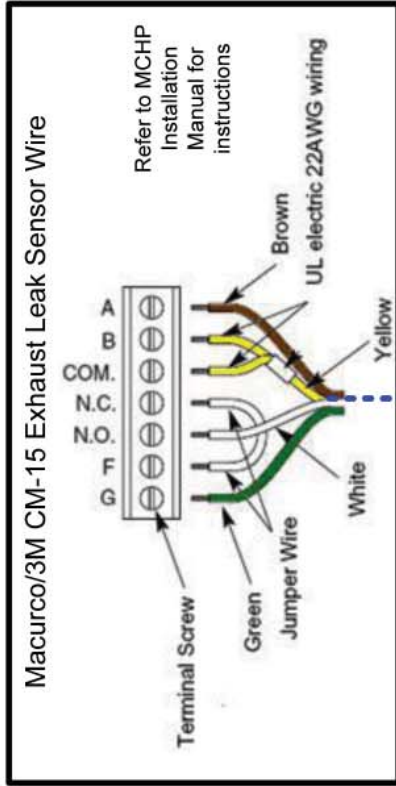
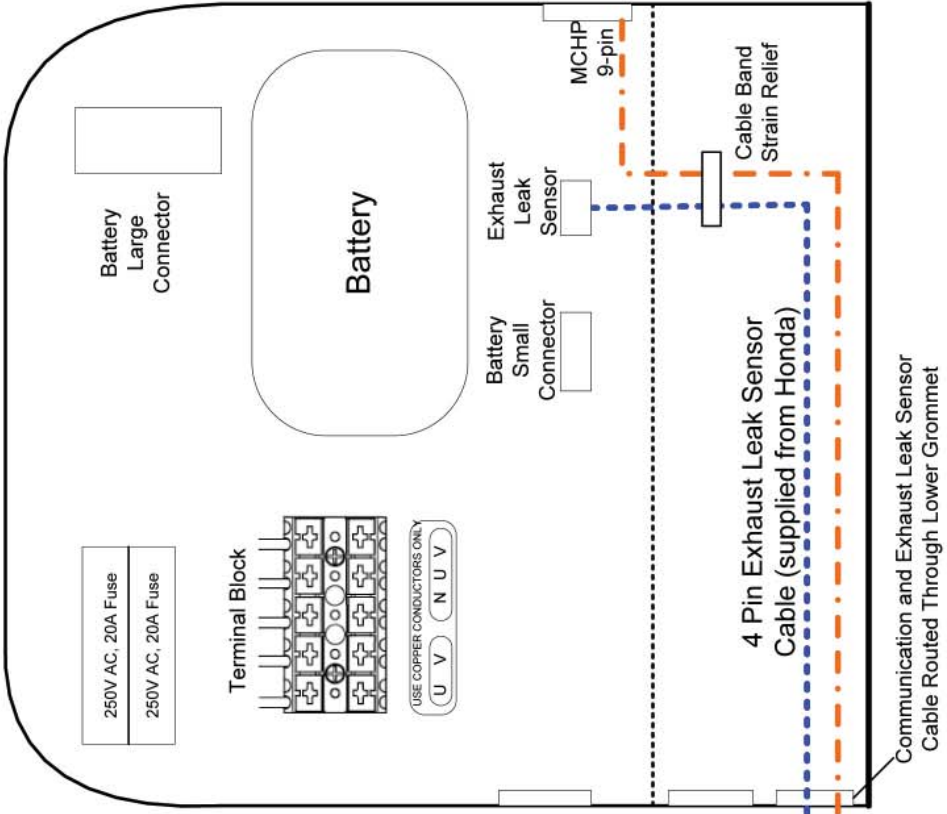

Note: CM-15 should be mounted approximately 5ft above floor level and at least 5ft away from a fuel gas burning appliance.

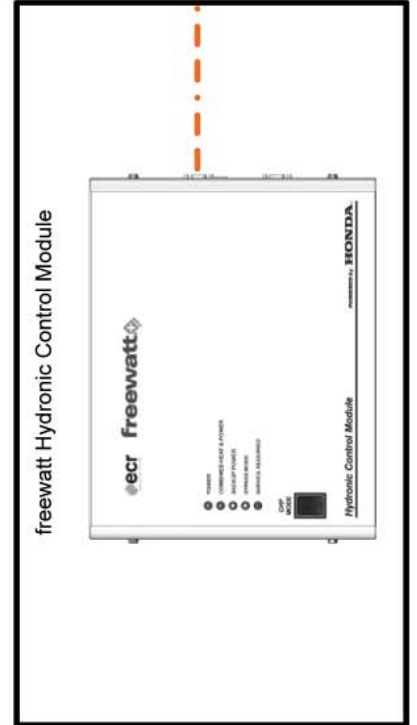

YM2J Communication Cable

freewatt®

Check our website frequently for updates: www.freewatt.com www.ecrinternational.com

