

CONTROL MODULE

050/075/100/150/200 REPLACEMENT KIT #550002298

INSTRUCTIONS

Kit installation shall be completed by qualified agency.

WARNING

Fire, explosion, asphyxiation and electrical shock hazard. Improper installation could result in death or serious injury. Read this instruction and understand all requirements, including requirements of authority having jurisdiction, before beginning installation. Installation not complete until appliance operation verified per Installation, Operation & Maintenance Manual provided with boiler.

Tools required:

- Slotted Screwdriver
- 1/4" Nut Driver

NOTICE

Replacement control module has factory default settings. Record all user parameters before replacing existing control. Refer to chart in START UP PROCEDURE in Installation, Operation & Maintenance Manual. Replacement control modules are universal to all models. Boiler model number will need to be selected on first use.

1. Follow instructions TO TURN OFF GAS TO APPLIANCE found on Operating Instructions label on boiler or in Installation, Operation & Maintenance Manual. Verify all electrical power to boiler is turned off.

WARNING

Electrical shock hazard. Turn OFF electrical power supply at service panel.

2. Remove front jacket panel(s).

WARNING

Burn hazard. Verify heat exchanger has cooled or use appropriate personal protection equipment.

3. Inspect combustion chamber through sight glass. Verify flame is not present. See figure 1.
4. Disconnect wire harnesses from control module.
5. Remove (4) 8-32 x 3/8 screws holding control module in place. See figures 2 and 3.
6. Attach new control module with (4) 8-32 x 3/8 screws. See figures 2 and 3.

Figure 1 - Sight Glass

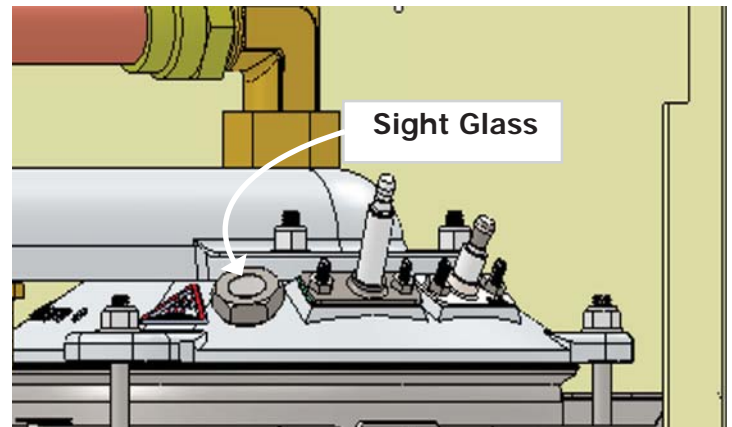
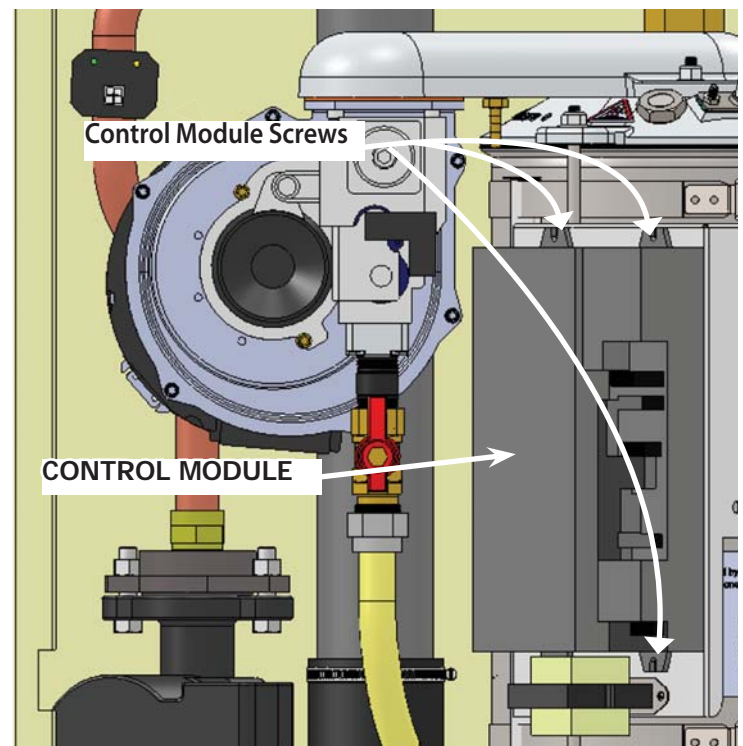

Figure 2 - Control Module



CONTROL MODULE

7. Connect wire harness to control module.

Table 1 - RPM SPEED

NOTICE

Control module has two (2) 4-wire connectors (J2 and J4). Wires into plugs are labeled to assist in connection to proper jack.

8. Select Model Number

- Press Reset, + and - Keys and hold simultaneously, while restoring electrical power to boiler.
- Continue pressing keys for approximately 30 seconds while control module initializes.
- Use +/- keys to select model shown on rating plate. Press Enter to complete selection.

9. Verify model selection.

- Installer Menu can be accessed by simultaneously holding 'Menu' and 'Enter' keys for 5 seconds.
- Press 'Enter'
- Scroll to fan speed section.
- Verify low and high RPM speed from Table 1.
- If RPM does not match model selected. Return to step 8 and re-select the model number shown on the rating plate.

10. Program Control Module Configurations and Settings recorded in Section 9 of Installation, Operation & Maintenance Manual.

11. Verify proper operation by following START UP PROCEDURE in Installation, Operation & Maintenance Manual.

12. Install front jacket panel(s).

MODEL	LOW	HIGH
50	1080	3720
75	1320	4980
100	1440	5760
150	1320	5040
200	1680	6060

Figure 3 - Control Module

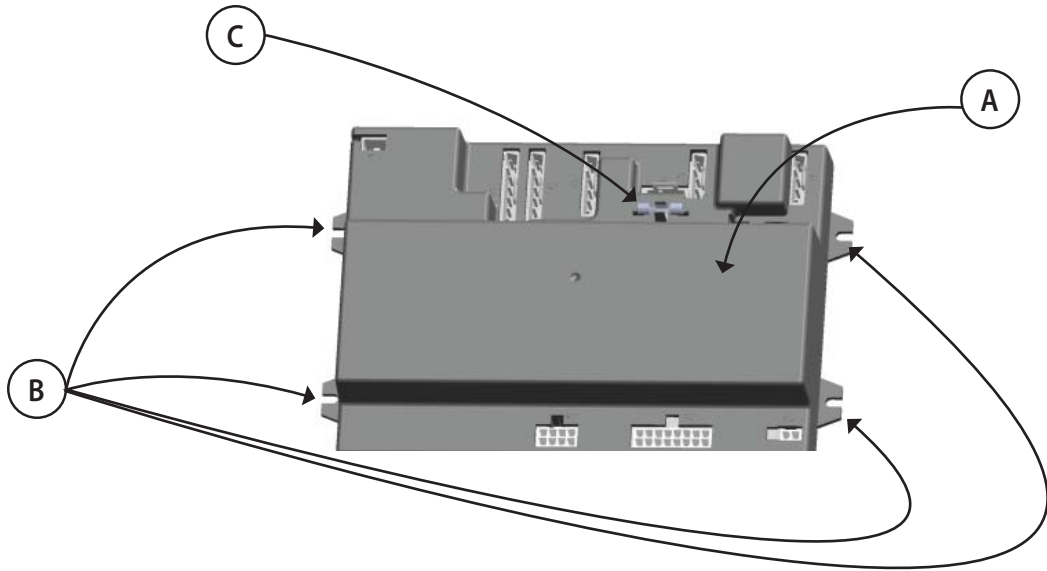

050/075/100/150/200 Control Module Kit # 550002298			
ITEM	DESCRIPTION	PART #	QTY
A	Control Module	-	1
B	Screw, 8-32 x 3/8, Slotted Self Tapping	-	4
C	Fuse, 3.15A ac, 250V, Slo-Blo Glass 5x20mm (Additional fuse is included with control module on Boiler)	240008665	1
*	Instructions	240008950	1

Check our website frequently for updates: www.ecrinternational.com