

REVISIONS				APPD
REV.	DATE	CR/CN	DESCRIPTION	PN
A	3/15/12	110095	RELEASE FOR PRODUCTION	PN

FRONT

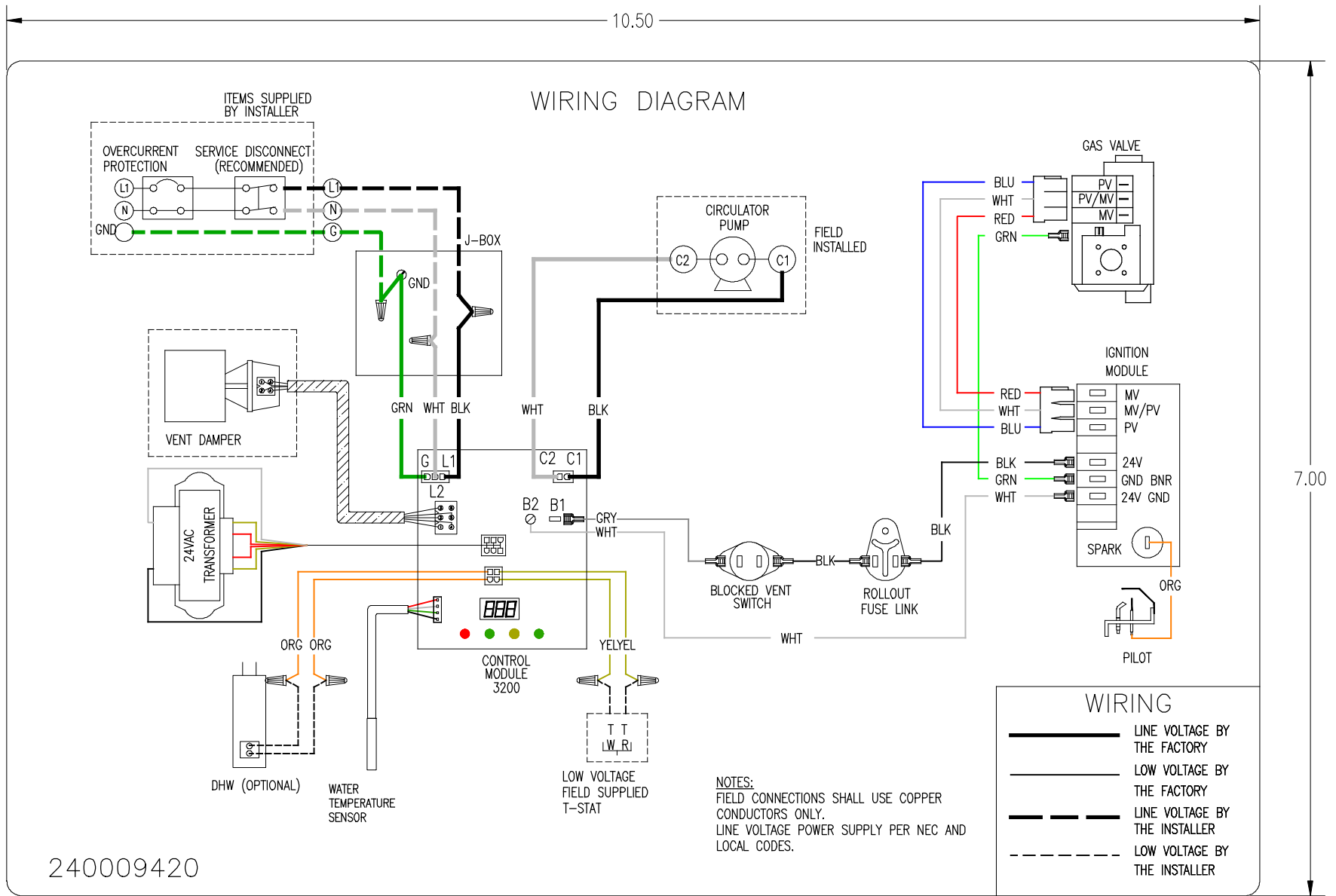

REAR

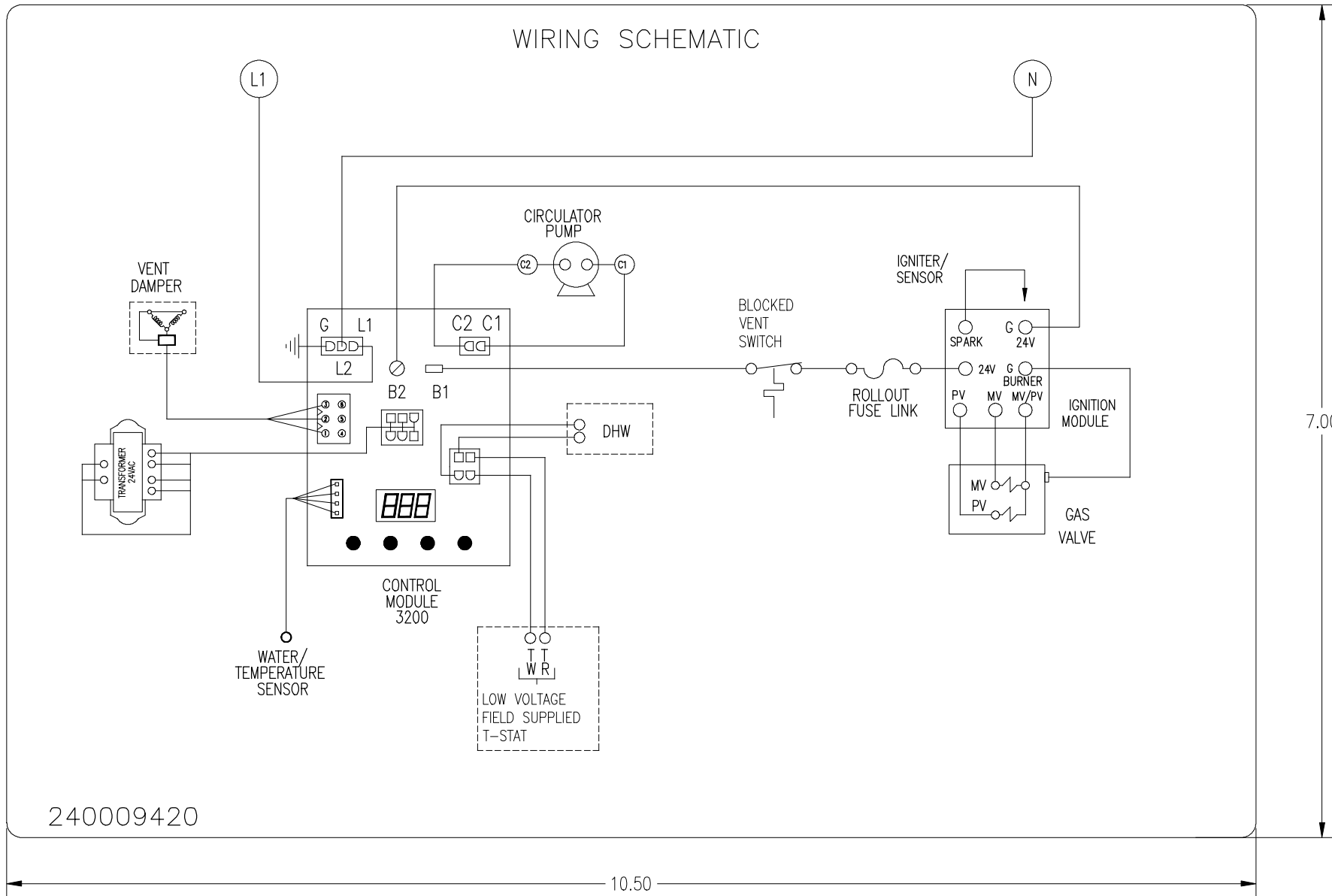

NOTES:

1. CURRENT MATERIAL NECUSSA 4 MIL THERMANENT DIGITAL POLY OR EQUIVALENT.
2. DIMENSIONS OF WIRING DIAGRAM SHEET ARE 8.50" X 11".
3. PAPER COLOR TO BE WHITE.
4. DIAGRAM TO BE 1 SHEET, FRONT AND BACK.

THIS DOCUMENT AND ITS CONTENTS CONSTITUTE PROPRIETARY TRADE SECRETS OF ECR INTERNATIONAL, INC. AND MAY NOT BE REPRODUCED, DISTRIBUTED OR USED IN ANY MANNER WITHOUT THE EXPRESS WRITTEN CONSENT OF AN AUTHORIZED REPRESENTATIVE OF ECR INTERNATIONAL, INC.

TITLE		eocr	
WIRE DIAGRAM INSERT, DXL		2201 Dwyer Ave. Phone:(315) 797-1310 Utica, N.Y. 13504 Fax:(315) 797-5372 e-mail: www.ecrinternational.com	
REFERENCE ASME Y14.5-1994 FOR GEOMETRIC DIMENSIONING, ALL DIMENSIONS IN INCHES. DRAWING NOT TO BE SCALED. NON-BASIC DIMENSIONAL AND ANGULAR TOLERANCES UNLESS OTHERWISE NOTED: DECIMALS: X.X - +/-0.1 X.XX - +/-0.03 X.XXX - +/-0.005 FRACTIONAL: +/- 1/32 ANGULAR: MACHINED - +/- 1' ANGULAR: FORMED - +/- 2'	SCALE 1:1	DATE 12/10/08	
	DRAWN BY MNV	CHKD FS	APPD PF
	MAT'L SEE NOTES		SHEET 1 OF 1
SIZE B	DWG NO. 240009420		REV A