



Models
Q90-125
Q90-150
Q90-175
Q90-200

Q90 125-200 SERIES II

**GAS-FIRED DIRECT VENT
CONDENSING HOT WATER BOILER**

INSTALLATION, OPERATION & MAINTENANCE MANUAL



An ISO 9001-2008 Certified Company

Manufactured by:
ECR International, Inc.
2201 Dwyer Avenue, Utica NY 13504-4729
web site: www.ecrinternational.com

P/N 240009431, Rev. C [07/2013]

TABLE OF CONTENTS

1 - Boiler Ratings & Capacities.....	3
2 - Safe Installation And Operation	5
3 - Locating The Boiler	6
4 - Near Boiler Piping	8
5 - Water Chemistry & Antifreeze Guidelines....	13
6 - Combustion Air/ vent Requirements	15
7 - Combustion Air And Vent Pipe	17
8 - Gas Supply Piping.....	21
9 - Electrical Wiring	22
10 - Controls And Accessories	26
11 - Startup.....	28
12 - Detailed Sequence Of Operation.....	31
13 - Sequence Of Operation Diagnostics	34
14 - Checkout Procedure & Adjustments	36
15 - Troubleshooting	38
16 - Maintenance And Cleaning	48

**KEEP THIS MANUAL NEAR BOILER
RETAIN FOR FUTURE REFERENCE**

IMPORTANT: Read following instructions COMPLETELY before installing!!

WARNING

Fire, explosion, asphyxiation and electrical shock hazard. Improper installation could result in death or serious injury. Read this manual and understand all requirements before beginning installation.

WARNING

Keep boiler area clear and free from combustible materials, gasoline and other flammable vapors and liquids.

DO NOT obstruct air openings to the boiler room. Modification, substitution or elimination of factory equipped, supplied or specified components may result in personal injury or loss of life.

TO THE OWNER - Installation and service of this boiler must be performed by a qualified installer.

TO THE INSTALLER - Leave all instructions with boiler for future reference.

When this product is installed in the Commonwealth of Massachusetts the installation must be performed by a Licensed Plumber or Licensed Gas Fitter.

Safety Symbols & Warnings

The following defined symbols are used throughout this manual to notify the reader of potential hazards of varying risk levels.

DANGER

Indicates a hazardous situation which, if not avoided, WILL result in death or serious injury

WARNING

Indicates a hazardous situation which, if not avoided, could result in death or serious injury.

CAUTION

Indicates a hazardous situation which, if not avoided, could result in minor or moderate injury.

NOTICE

Used to address practices not related to personal injury.

1 -BOILER RATINGS & CAPACITIES

Figure 1 - Boiler Jackets

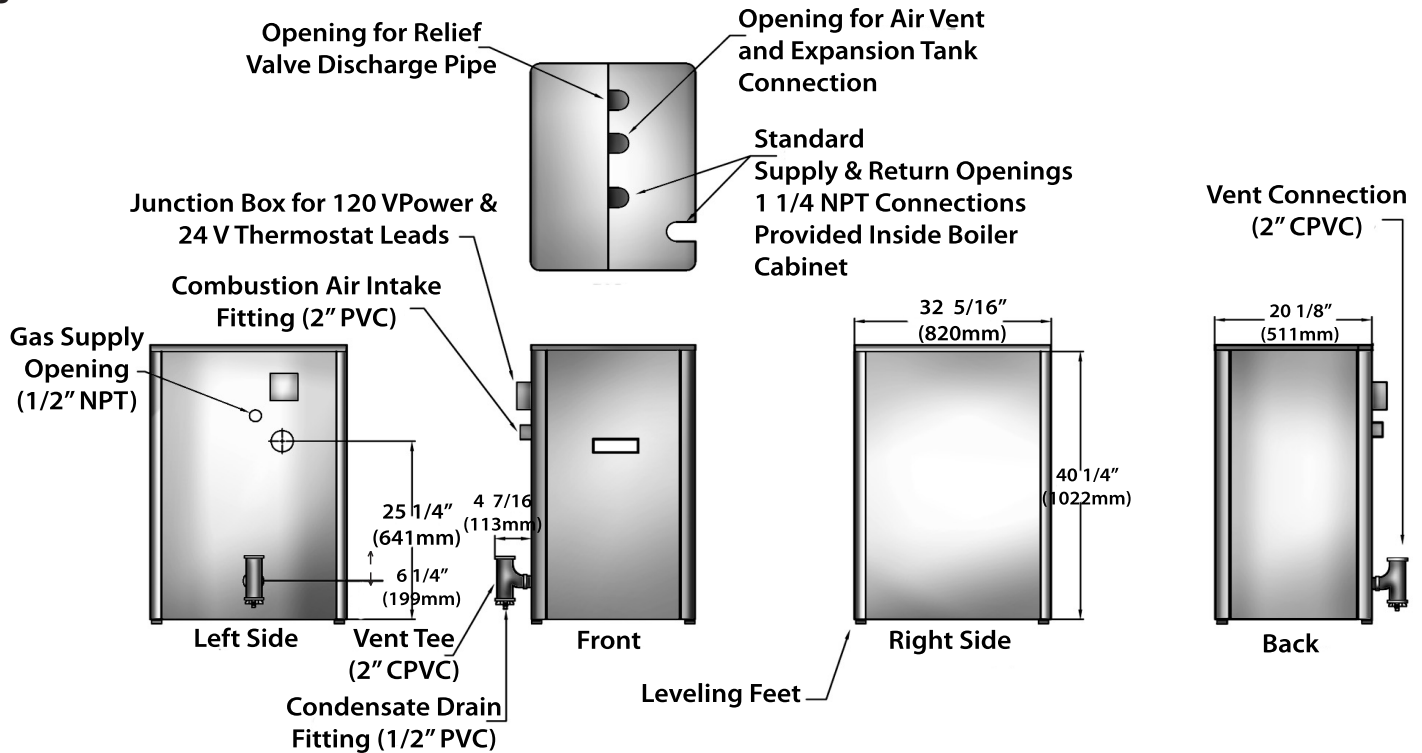

Table 1 - SEA LEVEL RATINGS (NATURAL AND PROPANE GASES)

Model	Input (MBH) ⁽¹⁾	Heating Capacity (MBH) ⁽¹⁾⁽²⁾	Net AHRI Rating (MBH) ⁽¹⁾	Shipping Weight (lbs.)	AFUE ⁽²⁾
125	125	113	98	284	90.0
150	150	134	117	284	90.0
175	175	158	137	284	90.0
200	200	180	157	284	90.0

⁽¹⁾ 1 MBH = 1,000 Btuh (British Thermal Units Per Hour)

⁽²⁾ AFUE (Annual Fuel Utilization Efficiency) and Heating Capacity is based on Department of Energy test procedure.

These low pressure gas-fired hot water boilers are design certified by CSA International, for use with natural and propane gases.

Boilers are constructed and hydrostatically tested for maximum working pressure of 50 psi (pounds per square inch) in accordance with A.S.M.E. (American Society of Mechanical Engineers) Boiler and Pressure Vessel Code, Section IV Standards for heating boilers.

Boilers are certified in accordance with ANSI (American National Standards Institute) Z21.13 standards as gas-fired, direct vent, condensing, hot water boilers.

Heating Capacity indicates amount of heat available after subtracting losses up the stack. Most of this heat is available to heat water. Small portion is heat loss from jacket and surfaces of boiler, it is assumed this heat stays in the structure. **Net AHRI Rating** represents portion of remaining heat applied to heat radiation or terminal units (i.e. Finned tube baseboard, cast iron radiators, radiant floor, etc.). Difference between Heating Capacity and Net AHRI Rating, called piping and pickup allowance, establishes reserve for heating volume of water in the system and offsetting heat losses from piping. Net AHRI Ratings shown are based on piping and pickup factor of 1.15. Net AHRI Rating of boiler selected should be greater than or equal to calculated peak heating load (heat loss) for building or area(s) served by boiler and associated hot water heating systems. Manufacturer should be consulted before selecting boiler for installations having unusual piping and pickup requirements.

1 - BOILER RATINGS & CAPACITIES

Ratings shown are for sea level applications. Boiler automatically derates input as altitude increases. No alterations to boiler are required for altitudes above sea level.

Table 2 - NATURAL GAS

Nominal Input	200,000		175,000		150,000		125,000	
	3" Vent Lengths		3" Vent Lengths		3" Vent Lengths		3" Vent Lengths	
Altitude	Min	Max	Min.	Max	Min.	Max	Min.	Max
0	200,000	200,000	175,000	175,000	150,000	150,000	125,000	125,000
1,000	197,000	196,500	172,400	172,200	147,800	147,400	123,500	123,000
2,000	194,000	193,000	169,800	169,400	145,600	144,800	122,000	121,000
3,000	191,000	189,500	167,200	166,600	143,400	142,200	120,500	119,000
4,000	188,000	186,000	164,600	163,800	141,200	139,600	119,000	117,000
5,000	185,000	182,500	162,000	161,000	139,000	137,000	117,500	115,000
6,000	182,000	179,000	159,400	158,200	136,800	134,400	116,000	113,000
7,000	179,000	175,500	156,800	155,400	134,600	131,800	114,500	111,000
8,000	176,000	172,000	154,200	152,600	132,400	129,200	113,000	109,000
9,000	173,000	168,500	151,600	149,800	130,200	126,600	111,500	107,000
10,000	170,000	165,000	149,000	147,000	128,000	124,000	110,000	105,000

Table 3 - LP GAS

Nominal Input	200,000		175,000		150,000		125,000	
	3" Vent Lengths		3" Vent Lengths		3" Vent Lengths		3" Vent Lengths	
Altitude	Min.	Max	Min.	Max	Min.	Max	Min.	Max
0	200,000	200,000	175,000	175,000	150,000	150,000	125,000	125,000
1,000	195,900	195,750	171,900	171,200	146,900	146,700	123,050	122,250
2,000	191,800	191,500	168,800	167,400	143,800	143,400	121,100	119,500
3,000	187,700	187,250	165,700	163,600	140,700	140,100	119,150	116,750
4,000	183,600	183,000	162,600	159,800	137,600	136,800	117,200	114,000
5,000	179,500	178,750	159,500	156,000	134,500	133,500	115,250	111,250
6,000	175,400	174,500	156,400	152,200	131,400	130,200	113,300	108,500
7,000	171,300	170,250	153,300	148,400	128,300	126,900	111,350	105,750
8,000	167,200	166,000	150,200	144,600	125,200	123,600	109,400	103,000
9,000	163,100	161,750	147,100	140,800	122,100	120,300	107,450	100,250
10,000	159,000	157,500	144,000	137,000	119,000	117,000	105,500	97,500

This is gas-fired direct vent cast aluminum hot water boiler. Cast aluminum heat exchanger means better heat transfer and thermal storage than similarly sized cast iron boilers, which results in higher efficiency. Heating system water absorbs large amounts of heat from cast aluminum heat exchanger, cooling flue gases and causing condensation. Sealed combustion, premix gas burner, and low flame temperature means drastically reduced CO and NOx emissions, which contribute to cleaner and healthier environment.

Appliance, unlike normal residential atmospheric and induced draft units, takes its combustion air directly from outdoors (sealed combustion) and does not compete with building occupants for fresh air. Sealed combustion (also known as "direct vent") is safest and best way to obtain plenty of clean combustion air. Forced draft fan draws in outside combustion air to mix with gas, which flows into pre-mix burner and combusts. Fan forces resulting flue gases from boiler unit and provides positive removal of flue gases from building through choice of PVC, CPVC or PP vent pipes. (Refer to Table 7 page 18 for material limitations.)

2 - SAFE INSTALLATION AND OPERATION

WARNING

Improper installation, adjustment, alteration, service or maintenance could result in death or serious injury.

Boiler is equipped for residential installations. If used for commercial applications; additional code requirements must be adhered to. This may require additional controls, including but not limited to manual reset low water cut off, manual reset high temperature limit, and wiring and/or piping modifications.

1. Installation must conform to the requirements of the authority having jurisdiction or, in the absence of such requirements, to the National Fuel Gas Code, ANSI Z223.1/NFPA 54 and/or Natural Gas and Propane Installation Code, CAN/CSA B149.1.
2. Where required by authority having jurisdiction, installation must conform to the Standard for Controls and Safety Devices for Automatically fired Boilers, ANSI/ASME CSD-1.
3. Be certain gas input rate is correct. Over-firing may result in early failure of boiler components; this may cause dangerous operation. Under-firing may result in too much air for pre-mix burner causing poor or loss of combustion.
4. Never vent products of combustion from this boiler to enclosed space. Always vent to outdoors. Never vent to another room or to inside building.
5. Verify adequate outdoor air supply to boiler for complete combustion.
6. Follow regular service and maintenance schedule for efficient and safe operation.
7. Keep boiler area clean of debris and free from combustible materials, gasoline and other flammable vapors and liquids.
8. Proper through-the-wall or through-the-roof combustion venting shall be in accordance with materials and methods described in this manual. Installation must comply with local codes.
9. Boiler and related hot water heating systems are not do-it-yourself items. Installation and service by qualified professionals are required.

Installers - Follow local regulations with respect to installation of CO (Carbon Monoxide) Detectors. Follow maintenance recommendations in this manual. See "Maintenance And Cleaning" on page 48.

Boiler Sizing

- Verify you have selected the boiler with proper capacity before continuing installation. AHRI Rating of boiler selected should be greater than or equal to calculated peak heating load (heat loss) for building or area(s) served by boiler and associated hot water heating systems. See "Boiler Ratings & Capacities" on page 3.
- Heat loss calculations should be based on approved industry methods.

Considerations For Boiler Location

Before selecting boiler location, consider following.

- Supplied with correct type of gas (natural gas or propane).
- Connected to suitable combustion air intake piping system to supply correct amount of fresh (outdoor) air for combustion. See "Combustion Air And Vent Pipe" on page 15.
- Connected to suitable venting system to remove hazardous products of gas combustion. See "Combustion Air And Vent Pipe" on page 15.
- Connected to suitable hot water heating system.
- Supplied with suitable electrical supply for all boiler motors and controls.
- Connected to properly located thermostat or operating control. (Not included with boiler)

WARNING

Fire hazard. Do not install boiler on carpeting. Failure to follow these instructions could result in death or serious injury.

- Placed on level surface (DO NOT install on carpeting)
- Condensate drain line must be pitched down to floor drain or external condensate pump with reservoir at ¼" per foot (21 mm/m) (wood frame or blocks may be used to raise boiler).

3 - LOCATING THE BOILER

Locating The Boiler

1. Select level location, central to piping systems served and close to vent and air intake terminals as possible.
2. Manufacture recommended accessibility clearances, if more stringent (i.e. larger clearances) than required fire protection clearances, must be used for boiler installation. Accessibility clearances may be achieved with use of removable walls or partitions.
3. Combustible clearances shown in Table 4 indicate required clearances per CSA listing. Minimum 1" (25 mm) clearance must be maintained between combustible construction and each of the right, top and back surfaces of boiler. Minimum 8" (203 mm) clearance is required on left side, to allow room for inlet air pipe. 18" (457 mm) clearance must be maintained at front where passage is required for cleaning or servicing, inspection or replacement of any parts that normally require such attention. Allow 24" (610 mm) at front and left side and 8" (203 mm) at top for servicing. No combustible clearances are required to venting or combustion air intake piping.

Table 4 - BOILER CLEARANCES		
Unit	Combustible Clearance	Accessibility, Cleaning, and Servicing
Top	1" (25 mm)	8" (203 mm)
Left Side	8" (203 mm)	24" (610 mm)
Right Side	1" (25 mm)	-
Base	1" (25 mm)	-
Front	0" (0 mm)	24" (610 mm)
Back	1" (25 mm)	-
Intake/Vent Piping	0" (0 mm)	-

All distances measured from boiler cabinet.

4. Keep boiler area clean of debris and free of flammable and combustible materials, liquids and vapors.
5. Install equipment in location which facilitates operation of venting and combustion air intake piping systems as described in this manual.
6. Advise owner to keep venting and combustion air intake passages free of obstructions. Both venting and combustion air intake piping systems connected to outdoors must permit flow through piping systems without restrictions for boiler to operate.

7. Boiler shall be installed such that automatic gas ignition system components are protected from water (dripping, spraying, rain, etc.) during operation and service (circulator replacement, condensate trap, control replacement, etc.).
8. Boiler must be located where ambient temperatures (minimum possible room temperatures where boiler is installed assuming boiler is not in operation and therefore contributes no heat to space) are always above freezing temperature.
9. If boiler is not level condensate drain lines will not function properly. Adjustable feet are located on boiler to make up for minor surface irregularities or tilt.
10. Wood frame or blocks may be used to raise boiler to maintain drain pitch or to be above external condensate pump reservoir.
11. Provide means for condensate drainage.

Removal Of Existing Boiler From Common Vent System

When an existing boiler is removed from a common venting system, the common venting system is likely to be too large for proper venting of the appliances remaining connected to it. At the time of removal of an existing boiler, the following steps shall be followed with each appliance remaining connected to the common venting system placed in operation, while the other appliances remaining connected to the common venting system are not in operation.

1. Seal any unused openings in the common venting system.
2. Visually inspect the venting system for proper size and horizontal pitch and determine there is no blockage or restriction, leakage, corrosion or other deficiencies which could cause an unsafe condition.
3. In so far as is practical, close all building doors and windows and all doors between the space in which the appliances remaining connected to the common venting system are located and other spaces of the building. Turn on clothes dryer and any appliance not connected to the common venting system. Turn on any exhaust fans, such as range hoods and bathroom exhaust, so they will operate at maximum speed. Do not operate a summer exhaust fan. Close fire dampers.
4. Place in operation appliance being inspected. Follow lighting instructions. Adjust thermostat so appliances operate continuously.
5. Test for spillage at draft hood relief opening after 5 minutes of main burner operation. Use flame of match or candle, or smoke from cigarette, cigar or pipe.

6. After it has been determined each appliance remaining connected to common venting system properly vents when tested as outlined above, return doors, windows, exhaust fans and any other gas-burning appliance to their previous condition.
7. Any improper operation of common venting system should be corrected so installation conforms with the National Fuel Code, ANSI Z223.1/NFPA 54. When re-sizing any portion of common venting system, common venting system should be re-sized to approach minimum size as determined using appropriate tables in chapter 13 of the National Fuel Code, ANSI Z223.1/NFPA 54.

Placing The Boiler

- Place boiler to provide most direct connections to combustion air, vent, and system piping as possible.
- Place crated boiler as close to selected location as possible and uncrate boiler.
- Move uncrated boiler into position with appliance dolly or 2-wheel hand truck.
- Insert dolly or hand truck under ***right hand side*** of boiler. It is possible to slide boiler for short distance on smooth floor or surface.

4 - NEAR BOILER PIPING

General Instructions

1. Packaged boiler is furnished with iron piping in front boiler section for supply and return connections.
2. Install all of radiation units (panels, radiators, baseboard, or tubing) and supply and return mains first, when installation of boiler is for new heating system.
3. After installation of all heating system piping and components; make final connection of system piping to boiler.
4. Hot water boiler installed above radiation level or as required by authority having jurisdiction must be equipped with low water cut off device (included with boiler).
5. Periodic inspection is necessary, as is flushing of float type devices, per low water cut off manufacturers specific instructions.
6. Proper water flow through any boiler is essential to proper operation and long life. Simple single or two zone systems with adequate flow do not require primary secondary piping. Systems with more zones or low flow require primary secondary piping.

Dielectric Isolation

1. Two (2) 1-1/4" X 1-1/4" female to female dielectric isolation unions are supplied. Install dielectric isolation unions at boiler supply line and return line. Install isolation fittings nearest boiler prior to system piping connections.
2. Water contaminants that cause low or high pH makes corrosion more likely.
3. Do not install copper supply and return piping directly into aluminum boiler section castings due to galvanic corrosion between dissimilar metals.
4. Use iron, steel bushings or pipe connectors between copper system piping and boiler to make final connection to boiler.
5. Use of dielectric unions is required, supplied with boiler, the purpose is to electrically insulate aluminum boiler from remainder of the system.

Figure 2 - General Primary Secondary Configuration

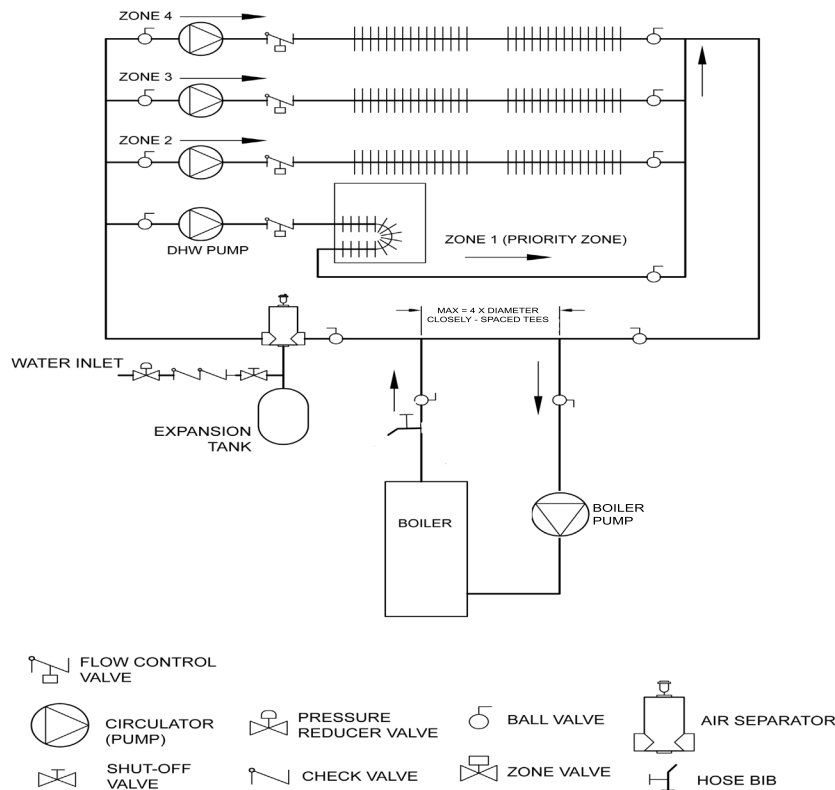

Expansion Tank And Make-Up Water

- Determine required system fill pressure, design temperature, and water content.
- Boiler contains 2.6 gallons (U.S.). Size expansion tank accordingly. Consult expansion tank manufacturer for proper sizing information.
- Connect properly sized expansion tank (not furnished) See Figure 3, for diaphragm type expansion tank. For diaphragm type expansion tanks, adjust tank air pressure to match system fill pressure.
- Install air vent (furnished) as shown for diaphragm type expansion tank system only.
- Install make-up water connections as shown and per local codes.
- If pressure reducing valve is used, adjust to match system fill pressure. Verify clean water supply is available when connecting cold make-up water supply to boiler. When water supply is from well or pump, install sand strainer at pump.

⚠ WARNING

Burn and scald hazard. Safety relief valve could discharge steam or hot water during operation. Install discharge piping per these instructions.

Safety Relief Valve / Temperature Pressure Gauge

Boiler is furnished with safety relief valve and temperature pressure gauge.

- Install safety relief valve using pipe fittings provided with boiler. Figure 2.
- Install safety relief valve with spindle in vertical position.
- Do not install shutoff valve between boiler and safety relief valve.
- Install discharge piping from safety relief valve.
 - A. Use $\frac{3}{4}$ " or larger pipe.
 - B. Use pipe suitable for temperatures of 375°F (191°C) or greater.
 - C. Individual boiler discharge piping shall be independent of other discharge piping.
 - D. Size and arrange discharge piping to avoid reducing safety relief valve relieving capacity below minimum relief valve capacity stated on rating plate.
 - E. Run pipe as short and straight as possible to location protecting user from scalding and properly drain piping.
 - F. Install union, if used, close to safety relief valve outlet.
 - G. Install elbow(s), if used, close to safety relief valve outlet and downstream of union (if used).
 - H. Terminate pipe with plain end (not threaded).

Figure 3 - Relief Valve Discharge Piping

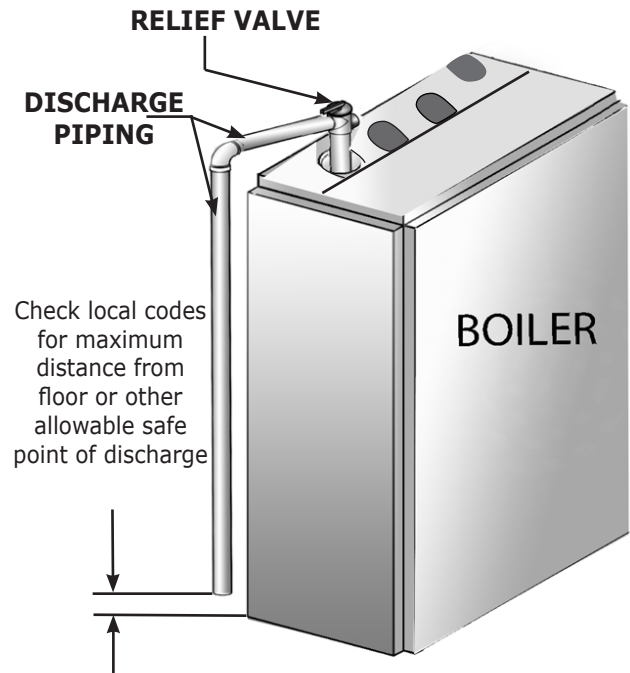

4 - NEAR BOILER PIPING

Figure 4 - Diaphragm Type Expansion Tank Piping

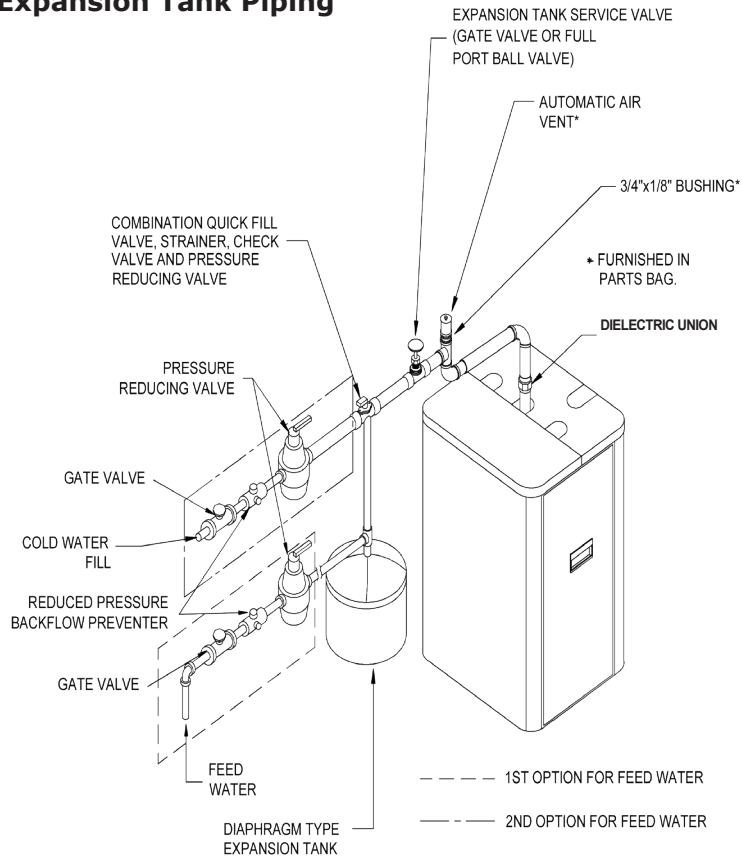
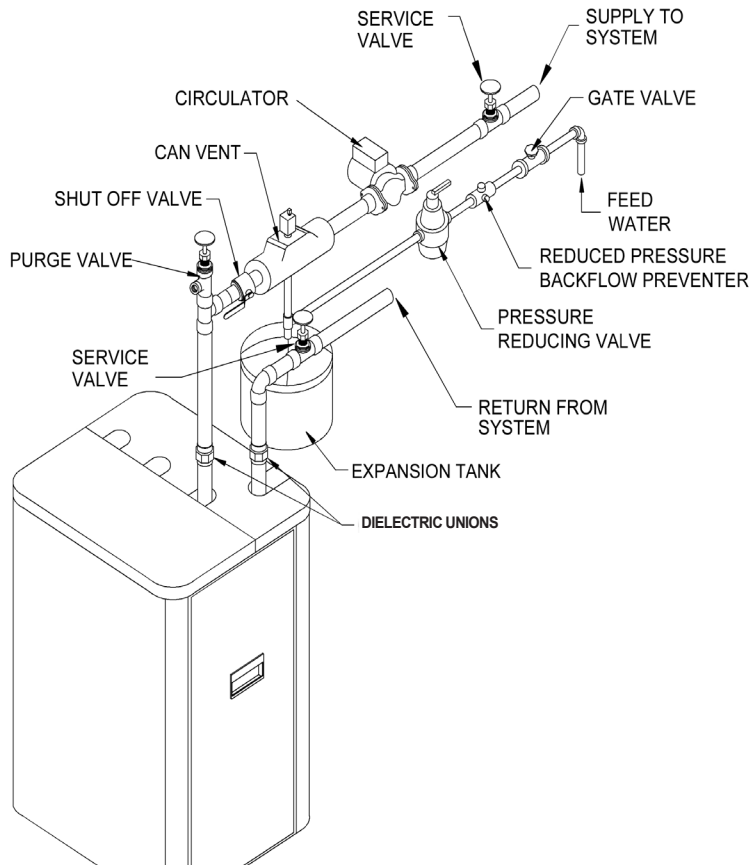
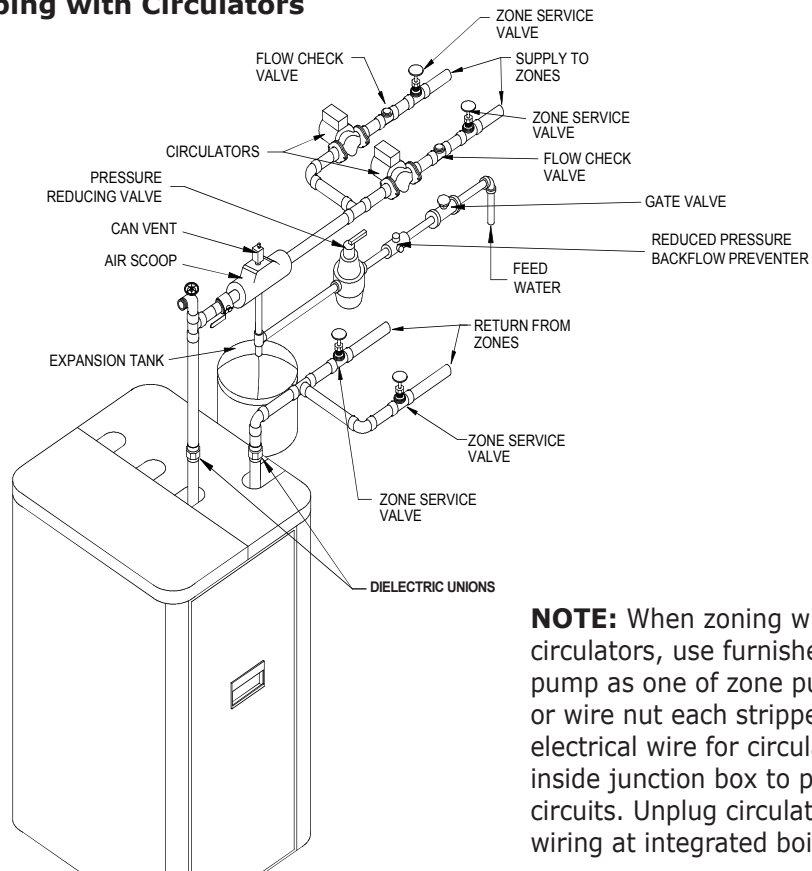

Figure 5 - Single Zone Boiler Piping



4 - NEAR BOILER PIPING

Figure 6 - Multi-zone Boiler Piping with Circulators



NOTE: When zoning with circulators, use furnished circulator pump as one of zone pumps. Tape or wire nut each stripped end of electrical wire for circulator pump inside junction box to prevent short circuits. Unplug circulator pump wiring at integrated boiler control.

Figure 7 Multi Zone Boiler Piping With Zone Valves

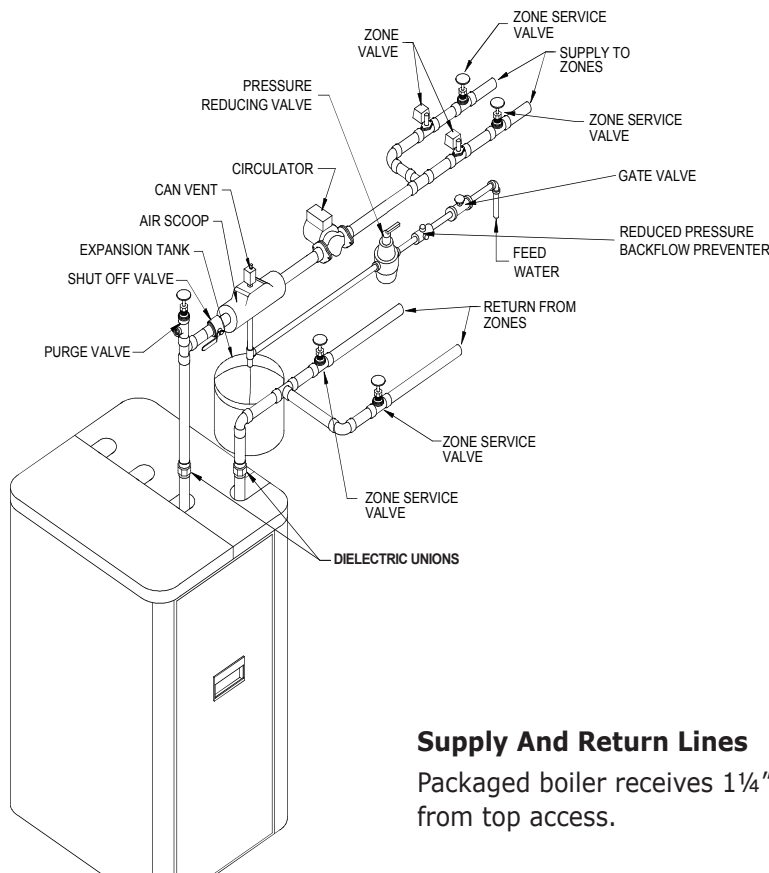

Supply And Return Lines

Packaged boiler receives 1¼" NPT supply and return piping from top access.

4 - NEAR BOILER PIPING

Condensate Drain Requirements

Pitch condensate drain line down to floor drain at minimum of ¼" per foot (21mm/m). External condensate pump (not furnished) may be used if floor drain is not available. Condensate pump must be designed for flue gas condensate application.

Condensate trap is proved with boiler.

1. Build condensate trap in the field. See Figure 7.
2. Wood frame or blocks may be used to raise boiler to maintain drain pitch or to be above external condensate pump reservoir.
3. 115 volt AC receptacle provided on service switch junction box which is located at boiler right side, to provide power for external condensate pump (if needed).

Condensate Drain Piping

- Condensate trap is to be field installed as shown in Figure 7.
- Provided are ½" PVC fittings for condensate drain trap (assembled in field).
- The ½" diameter schedule 40 PVC condensate drain piping and pipe fittings must conform to ANSI standards and ASTM D1785 or D2846.
- Schedule 40 PVC cement and primer must conform to ASTM D2564 or F493. In Canada, use CSA or ULC certified schedule 40 PVC drain pipe and cement.

- Condensate pump with reservoir (not furnished) may be used to remove condensate to drain line (sanitary line) above boiler if floor drain is not available or is inaccessible

Filling Condensate Trap With Water

Manually fill condensate trap at initial start up with water. Following steps are required to fill condensate trap for start up. Steps are only required at initial start up or if maintenance requires draining of condensate trap:

1. Pour about 1 cup of cold tap water into condensate trap vent.
2. Excess water will go through condensate drain line. Verify proper operation of drain line (and external condensate pump if used).

Chilled Water Piping

Install boiler used in connection with refrigeration system, so chiller medium is piped in parallel with boiler with appropriate valves to prevent chilled medium from entering boiler.

Boiler piping system of hot water boiler connected to heating coils located in air handling units where they may be exposed to refrigerated air circulation must be equipped with flow control valves or other automatic means to prevent gravity circulation of boiler water during cooling cycle.

Figure 8 - Condensate Trap and Vent

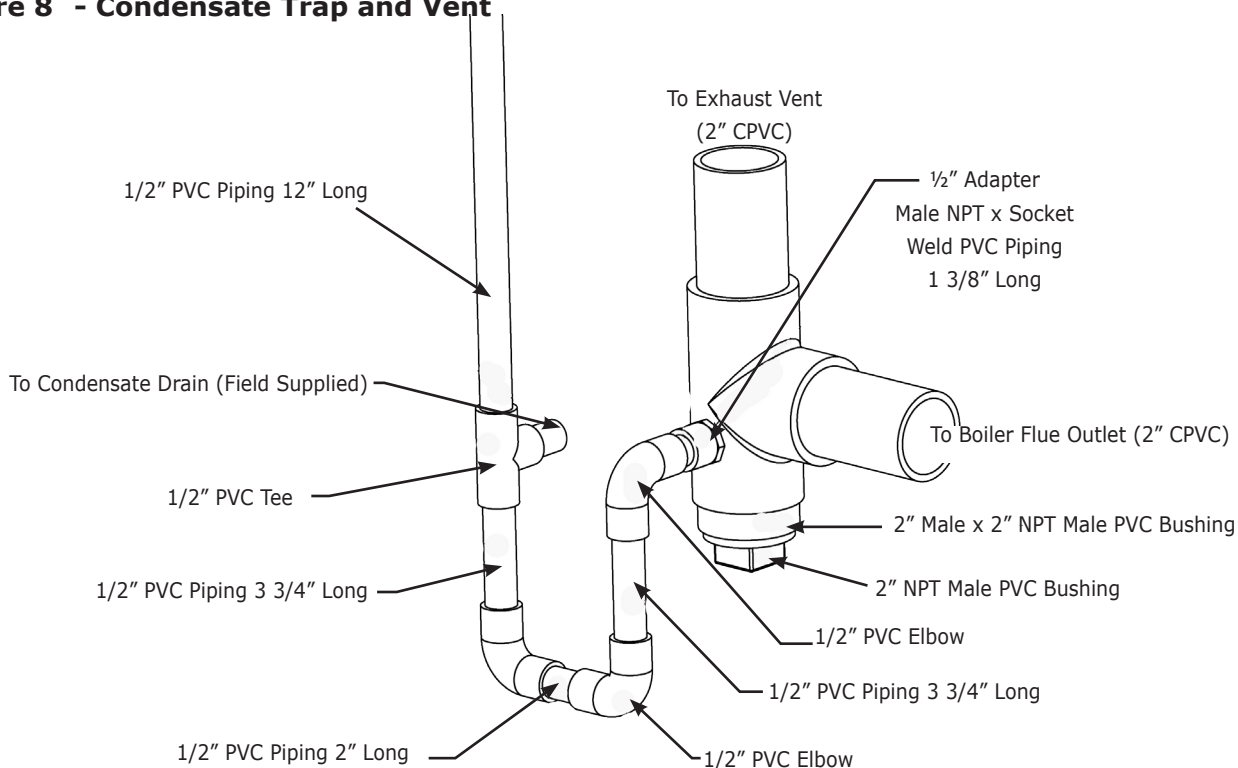

WARNING

Fire, explosion, asphyxiation hazard. Inadequate dielectric isolation, incorrect water treatment or antifreeze application may cause damage to boilers heat exchanger. Improper installation could result in death or serious injury. Follow these instructions completely.

Boiler Water Quality and Antifreeze

Water treatment and antifreeze protection must be applied to all aluminum series high efficiency gas-fired boilers using antifreeze protection.

Clean System First

- Before connecting boiler to heating system, clean and flush system thoroughly. Verify system is free of sediment, flux and residual boiler water additives.
- Systems having antifreeze not recommended must be completely flushed to ensure no old antifreeze remains. In older systems obviously discolored, murky or dirty water; or pH reading outside acceptable range (between 7.0 and 8.0) are indications system should be cleaned or treated. Thoroughly flush system with clean water to remove sediment or contaminants. Sludge and iron oxide deposits can cause rapid breakdown of inhibitors.
- Flush with clean water. If chemical cleaners are used, use only those recommended for use with aluminum boilers. Follow chemical cleaner manufacturer's instructions completely.
- DO NOT mix different manufacturer's products.

Fill Water and Chemistry

Verify water used to fill system meets these requirements:

- System fluid pH maintained between 7.0 and 8.0.
- Maintain water hardness below 7 grains hardness.
- Filling with chlorinated potable water is acceptable. DO NOT fill boiler with water containing chlorine in excess of 100 ppm.
- DO NOT use inhibitors or other additives that are not listed.
- Consult local water treatment specialist for recommendations if any of above requirements is outside stated ranges.

Eliminate System Leaks

- Continuous addition of make-up water will constantly add oxygen to system. Eliminate all system leaks. All system leaks must be repaired immediately.
- Verify expansion tank is operational and properly sized. Undersized expansion tanks cause relief valve weeping and substantial make-up water addition.
- Operation of this boiler in a system containing significant amounts of dissolved oxygen can cause severe heat exchanger corrosion damage.
- This boiler is not designed for use in systems containing regular additions of make-up water. Regular additions of make-up water may cause severe heat exchanger damage. System leaks may not always be visible. Unseen system leak will become obvious if boiler pressure decreases when make-up valve is closed.

- This boiler is designed for closed loop hydronic heat system only. Boiler is not suitable for natural gravity type installations, or any other open type system.

General Guidelines When Using Antifreeze

- Use only antifreeze products recommended for use with aluminum boilers. See Table 5 page 14.
- Continuous addition of make-up water will dilute power of antifreeze and change buffers ability to maintain pH.
- Flush old antifreeze from system. Flush boiler and system separately.
- Do not use antifreeze unless required.
- Antifreeze must be of type as listed in this manual due to their operational characteristics of : type 356 T6 aluminum at operating temperatures between 20°F (-6.7°C) and 250°F (121°C).
- Always clean system prior to using antifreeze.
- Follow antifreeze manufacturer's instructions for use, safe handling and storage. Refer to MSDS (Material Safety Data Sheets) provided by antifreeze manufacturer for potential hazards and first aid procedures for exposure or ingestion.
- Antifreeze will raise pH of hydronic solution in heating system above recommended level due to corrosion inhibitors. Solution must be treated to maintain pH within recommended level. Follow antifreeze manufacturer's instructions to adjust pH.
- If system leaked, adjust water and antifreeze chemistry. To avoid damage to boiler, check pH and chemistry of boiler solution. Consult antifreeze manufacturer for recommendations.
- Take pH reading annually, and adjust as necessary. Follow antifreeze/inhibitor manufacturer's instructions for details on how to adjust pH.
- Antifreeze solutions can break down over time. Failure to check antifreeze chemistry on annual basis may result in accelerated corrosion of boiler and other system components. Consult with antifreeze manufacturer for recommendations.
- Use of antifreeze in any boiler will reduce heating capacity as much as 10-20%. Take into consideration when sizing heating system, pumps and expansion tank. Consult antifreeze manufacturer's literature for specific information on reduced capacity.
- Using antifreeze manufacturer's instructions, determine freezing temperature needed and use correct amount of antifreeze. Never exceed 50% antifreeze by volume.
- Boiler operating pressure must remain below 15 psi for antifreeze solutions that specify maximum of 250°F (121°C). Otherwise, increase system operating/tank pressure to 20 psig. Refer to expansion tank manufacturer instructions for adjusting tank pressure.

5 - WATER CHEMISTRY AND GENERAL ANTIFREEZE GUIDELINES

Table 5 - Compatible Aluminum Antifreeze & Inhibitor Suppliers

Noburst AL Antifreeze	Noble Company P. O. Box 350 Grand Haven, MI 49417 www.noblecompany.com Tel: 800-878-5788 Fax: 231-799-8850
Rhogard Antifreeze & Pro-Tek 922 Inhibitor*	Rhomar Water Management, Inc. P. O. Box 229 Springfield, MO 65801 www.rhomarwater.com Tel: 800-543-5975 Fax: 417-862-6410
* Pro-Tek 922 Inhibitor may be used to adjust the pH level of the hydronic system, but on occasion may not resolve the pH issue. In these cases, flush the system and refill with untreated water and antifreeze suitable for aluminum heat exchangers, as listed in this supplement.	
Alphi-11	Hydronic Agencies, Ltd. (Fernox North Distributor) 15363 117 Avenue Edmonton, AB T5M 3X4 Canada www.hydronicagencies.com Tel: 780-452-8661 Fax: 780-488-2304 Fernox www.fernox.com
Intercool NFP-30,40,50 AA Intercool RPH-15*	Interstate Chemical 2797 Freedland Road P.O. Box 1600 Hermitage, PA 16148-0600 www.interstatechemical.com Tel: 800-422-2436 Fax: 724-981-8383
Hercules cryo-tek™-100/Al	Hercules Chemical Company, Inc. 111 South Street Passaic, NJ 07055 www.herchem.com Tel: 800-221-9330 Fax: 800-333-3456
* This product may be used to adjust pH level of hydronic system, but on occasion may not resolve pH issue. In these cases it is recommended to flush system and refill with untreated water and new boiler manufacturer approved antifreeze suitable for Aluminum heat exchangers.	

Combustion Air/Vent Pipe Requirements

Boiler requires dedicated direct vent system. Direct vent system, all air for combustion is taken directly from outside atmosphere, and all flue products are discharged to outside atmosphere.

Combustion air and vent pipe connections must terminate together in same atmospheric pressure zone, either through roof or sidewall (roof termination preferred). See Figures 8 and 9 for required clearances.

Venting must be as direct as possible and properly supported.

Figure 9 - Multiple Boiler Roof Vent/Intake Terminations

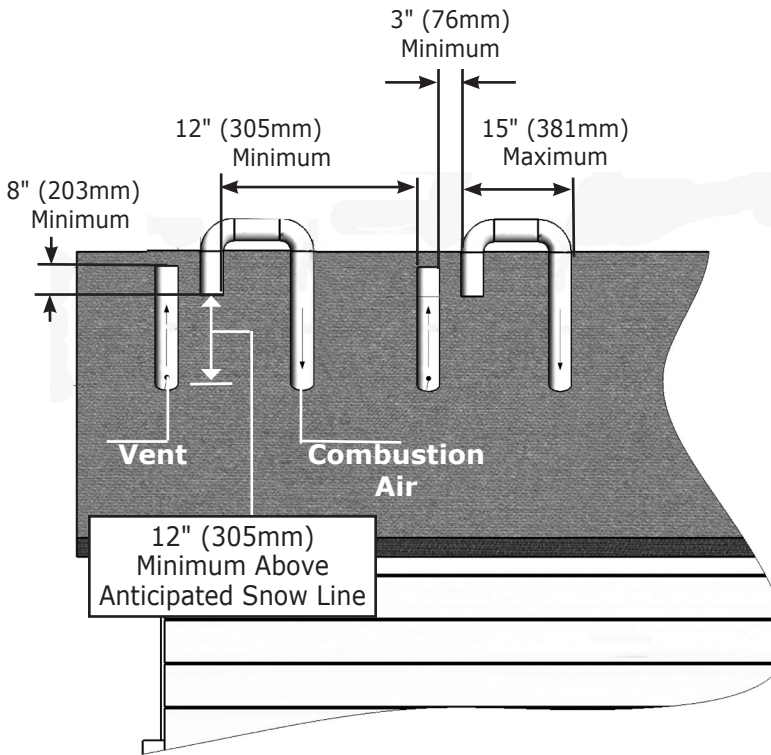
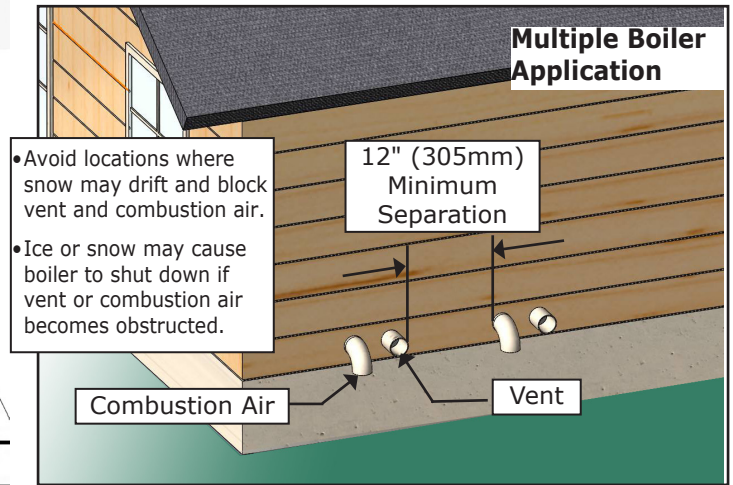
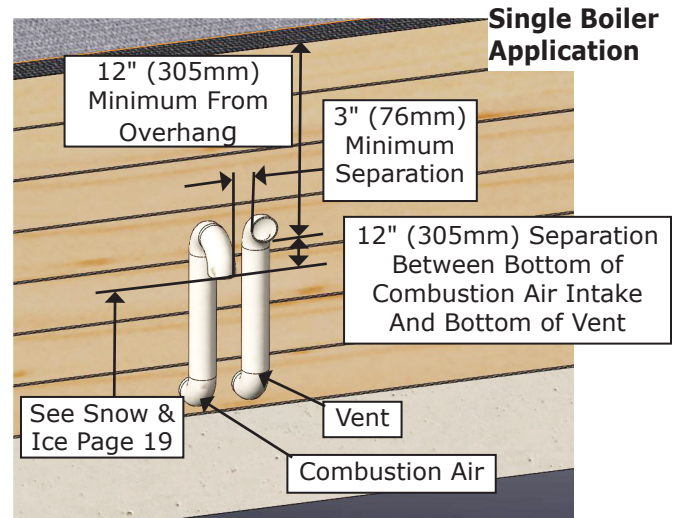
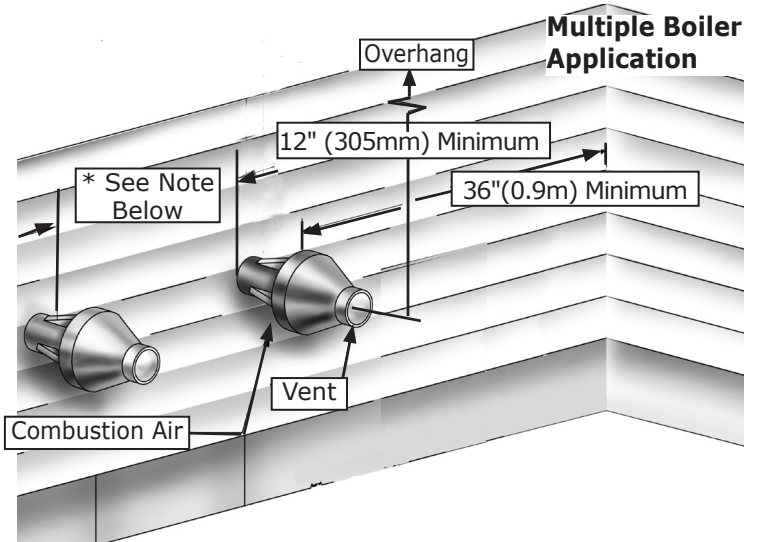
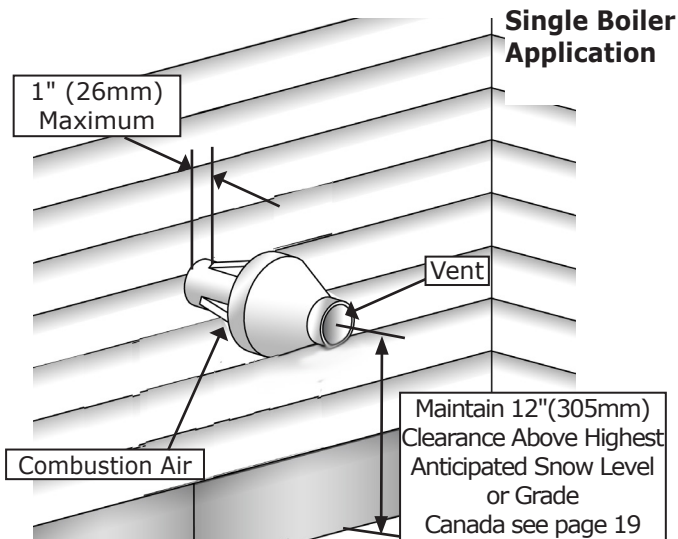

Figure 10- Sidewall Vent/Intake Terminations



If concentric vent termination is being used, refer to Figure 10 for proper setup.

Figure 11- Concentric Vent Terminations



*Must be less than 4" or greater than 24" Horizontal distance between end bells of each air intake to prevent flue gas recirculation.

6 - COMBUSTION AIR/ VENT REQUIREMENTS

⚠ WARNING

Fire, explosion, asphyxiation hazard. Solvent cements are combustible. Keep away from heat, sparks, or open flame. Use only in well ventilated areas. Avoid breathing in vapor or allowing contact with skin or eyes. Improper installation could result in death or serious injury. Read this manual and understand all requirements before beginning installation.

⚠ WARNING

Fire, asphyxiation hazard. Covering non-metallic vent pipe and fittings with thermal insulation shall be prohibited. Improper installation could result in death or serious injury.

- Combustion air must be clean outdoor air. Do not take combustion air from inside structure because that air is frequently contaminated by halogens, which includes fluorides, chlorides, phosphates, bromides and iodides. These elements are found in aerosols, detergents, bleaches, cleaning solvents, salts, air fresheners, paints, adhesives, and other household products. Typical areas of contamination include dry cleaning facilities, swimming pools, beauty shops, new building construction, air conditioning equipment. For example combustion air intake near swimming pool chemicals will damage any condensing boiler.
- Locate combustion air inlet as far away as possible from swimming pool and swimming pool pump house.
- All combustion air and vent pipes must be airtight and watertight.
- Follow instructions in this manual for combustion air and vent piping termination.
- Use of concentric vent termination refer to Figures 10, 11 and 12 for proper setup.
- Vent connections serving appliances vented by natural draft shall not be connected into any portion of mechanical draft systems operating under positive pressure.
- Fully support all vent piping. Use hangers at intervals to prevent pipe from sagging.

Figure 12- Concentric Vent

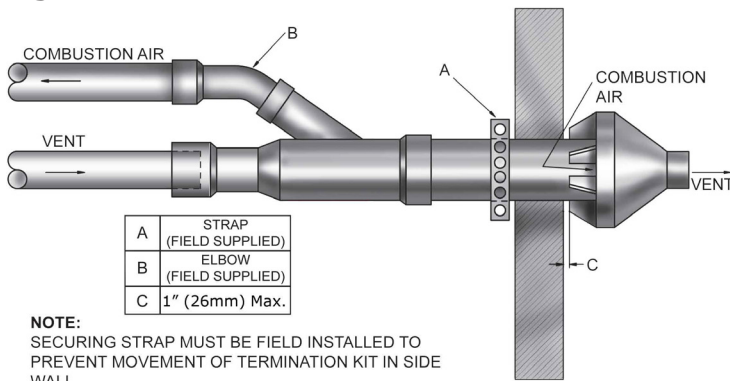
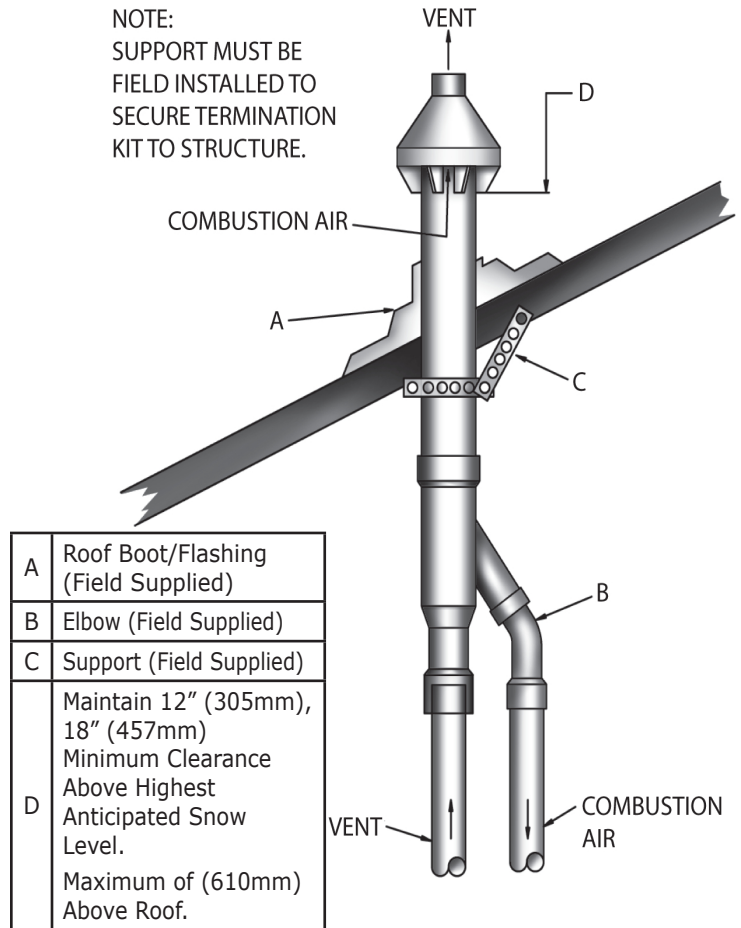

Figure 13- Concentric Vent Roof Installation



NOTICE

Properly support venting. Boiler is not designed to bear weight of venting system.

Dimension		Dimension	
A	3" Diameter PVC Vent/Exhaust	D	1 ³ / ₁₆ "
B	1 ¹ / ₂ "	E	46 ³ / ₄ "
C	3" Diameter PVC Intake/Combustion Air	F	31 ⁷ / ₈ "
		G	4 ¹ / ₂ " Dia.

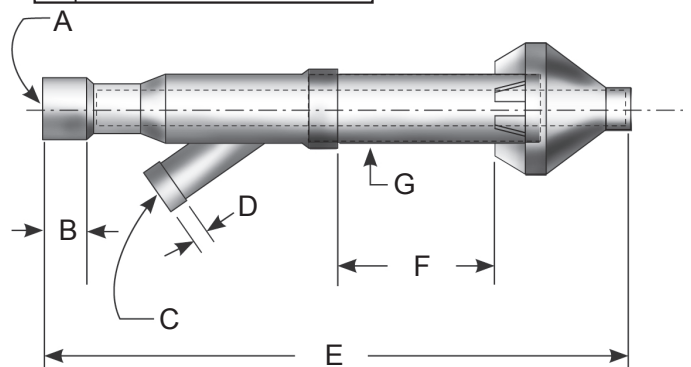

Connections And Termination

Installation must conform to requirements of authority having jurisdiction or, in absence of such requirements, to the section for Air for Combustion and Ventilation of the National Fuel Gas Code, ANSI Z223.1/NFPA 54 and/or Natural Gas and Propane Installation Code, CAN/CSA B149.1.

Installer must clean and remove all shavings from interior of all pipes used on air intake to prevent damage to gas burner and ensure proper operation.

Boilers require dedicated direct vent system. All air for combustion is taken directly from outdoors through combustion air intake pipe. All flue products are discharged to outdoors through vent pipe. Install vent system in accordance with instructions in this manual.

1. Figures 8 and 9 "Combustion Air and Vent Pipe Requirements, for standard two-pipe roof and sidewall terminations and Figures 10, 11, and 12 for concentric vent terminations (roof termination is preferred). Combustion air and vent pipes must terminate together in same atmospheric pressure zone as shown. Construction through which vent and air intake pipes may be installed is minimum ¼" and maximum 24" thickness.
2. Combustion air and vent pipe fittings must conform to one of the following American National Standards Institute (ANSI) and American Society for Testing and Materials (ASTM) standards:
3. Combustion air and vent piping connections on boiler are 2", but must increase to 3". Due to potential for flue gas temperatures over 155°F, first 5 feet of vent pipe must be CPVC (furnished), remaining vent pipe can be PVC. This requirement is not required when using PP. If any elbows are employed within first 2½' of vent, they must be CPVC. Two 30" pieces of 2" CPVC pipe and one 2" CPVC coupling are furnished with boiler. See Figure 13.

Length of pipe is counted from boiler jacket (air intake pipe) or from vent tee (vent pipe). First five feet of "Total Equivalent Length" of vent pipe must be CPVC. This requirement is required when using PP.

Reduce maximum vent length 5 feet per each additional elbow.

4. Pitch horizontal combustion air and vent piping back to boiler at minimum ¼" per foot (21mm/m) from intake and vent terminals so all moisture in combustion air and vent piping drains to boiler. Pitch pipes continuously with no sags or low spots where moisture can accumulate and block flow of air or flue gas. This blockage may cause combustion instability, noise and lead to nuisance control lockouts.
5. Combustion air and vent pipes must be airtight, watertight and tested for leaks.

WARNING

Use of cellular core PVC (ASTM F891), cellular core CPVC, or Radel® (polyphenolsulfone) in venting system could result in death, serious injury.

Table 6 Combustion Air and Vent Pipe Length Requirement

3 in. Pipe Minimum Venting	* 3 in. Pipe Maximum Venting
6 ft. (1.8 m) in length	60 ft. (18.3 m) in length and up to four (4) 90° elbows
1 - 90° elbow = 5 ft (1.6 m) 1 - 45° elbow = 3.5 ft (1.1 m) 1- 2" x 3" adapter = 0 ft (0 m)	
All field installed vent pipe must be 3" * Past first 2" section provided with boiler	

7 - COMBUSTION AIR AND VENT PIPE

Table 7 - Combustion air and vent pipe fittings must conform with the following:			
Item	Material	USA Standard	Canadian Standard
Exhaust and/or Intake Air Pipe and Fittings	PVC	UL1738 ULC S636 ASTM D1785 ASTM D2241 (Fittings) D2466	(Pipe & Fittings) ULC S636
	CPVC	UL1738 ULC S636 F441 (Fittings) F439	(Pipe & Fittings) ULC S636
	Polypropylene (PP)	UL1738 ULC S636	(Pipe & Fittings) ULC S636
Intake Air ONLY Pipe and Fittings	PVC	ASTM D2665	(DWV) CSA B181.2 (SCH 40) CSA B137.3
	ABS	ASTM D3965 ASTM D2661	CSA B181.1
Pipe Cement And Primer	PVC	ULC S636 ASTM D2564	ULC S636 (Exhaust & Air Intake) CSA B137.3 (Air Intake ONLY) CSA B181.2 (Air Intake ONLY)
	CPVC	ULC S636 ASTM F493	ULC S636 (Exhaust & Air Intake) CSA B137.6 (Air Intake ONLY) CSA B181.2 (Air Intake ONLY)
	ABS	ASTM D2235	ULC S636 (Exhaust & Air Intake) CSA B181.1 (Air Intake ONLY)

Figure 14- Combustion Air & Vent Piping

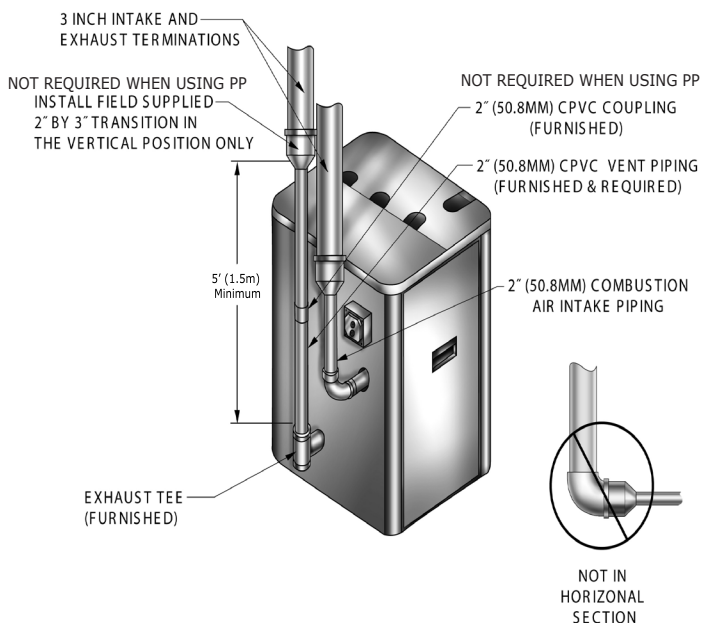

NOTICE

Exhaust transition from 2" pipe to 3" pipe must be made in vertical run. (Transition pieces not included.)

6. General Installation Requirements:

- A. Position termination where vent vapors will not damage plants/shrubs, air conditioning equipment, or siding on the house.
- B. Position termination so it will not be effected by wind eddy, air born leaves, snow, or recirculated flue gases. For high wind location termination tees are required.
- C. Position termination where it will not be subjected to potential damage by foreign objects, such as stones, balls, etc.
- D. Position termination where vent vapors are not objectionable.
- E. Put vent on wall away from prevailing winter wind. Locate or guard vent to prevent accidental contact with people or pets.
- F. Avoid locations where snow may drift and block vent. Ice or snow may cause boiler to shut down if vent becomes obstructed.
- G. Under certain conditions, flue gas will condense, forming moisture, and may be corrosive. In such cases, take steps to prevent building materials at vent from being damaged by exhaust of flue gas.

US Installation Requirements

- Venting system shall terminate at least 3 ft. (0.9m) above any forced (mechanical) air inlet located within 10 ft. (3m) horizontally to any building.
- Venting system shall terminate minimum of 1 ft. (0.3m) above grade or expected snow level in such a way that it cannot be blocked by snow.
- Termination shall be not less than 7 ft. (2.1m) above adjacent public walkway, paved driveway or sidewalk.
- Vent terminal shall not be installed closer than 3 ft. from inside corner of L shaped structure.
- Venting system shall terminate at least 1 ft. from any air opening (i.e. window, door, or non-mechanical inlet) into any building.
- Vent termination should be kept at least 3 ft. away from vegetation.
- Venting system shall terminate at least 4 ft. horizontally from, and in no case above or below, unless 4 ft. (1.22m) horizontal distance is maintained, from electric meters, gas meters, regulators, and relief equipment.
- Venting system shall not terminate where hot gases can cause property damage, personal injury, or where condensate may cause hazardous frost or ice accumulations.

- Every outside wall penetration shall be permanently sealed to prevent entry of combustion products into building.
- Venting that discharges flue gases perpendicular to the adjacent wall shall be located not less than 10 ft. (3m) horizontally or must be a minimum of 2 ft. (0.6m) above or must be a minimum of 25 ft. (7.6m) below from an operable opening in an adjacent building.

Canadian Installation Requirements

- Venting system shall terminate at least 6 ft. (1.8m) away from any forced (mechanical) air inlet to any building.
- Venting system shall terminate a minimum of 1 ft. (0.3m) above grade or expected snow level such a way that it cannot be blocked by snow.
- Termination shall be not less than 7 ft. (2.1m) above adjacent public walkway, paved driveway or sidewalk
- Vent terminal shall not be installed closer than 3 ft. from inside corner of L shaped structure.
- Vent shall not terminate within 1 ft. (0.3 m) for inputs up to and including 100,000 Btu/hr (30kW) and 3 ft. (0.9 m) for inputs exceeding 100,000 Btu/hr (30kW) of window or door that can be opened in any building, of any non-mechanical air-supply inlet to any building, or of combustion air inlet of any other appliance.
- Venting system shall terminate at least 4 ft. horizontally from, and in no case above or below, unless 4 ft. (1.22m) horizontal distance is maintained, from electric meters, gas meters, regulators, and relief equipment.
- Venting system shall not terminate where hot gases can cause property damage, personal injury, or where condensate may cause hazardous frost or ice accumulations.
- First 3 feet (900mm) of plastic venting must be readily accessible for visual inspection.**
- Vent shall not terminate underneath veranda, porch or deck unless,
 - a. The veranda, porch or deck is fully open on minimum of two sides beneath floor, and
 - b. The distance between top of vent termination and the underside of the veranda, porch or deck is greater than 1 ft. (0.3 m).

Installation

1. Recommend all pipes be cut, prepared, and pre-assembled before permanently cementing any joint.
2. Rigid supports cause excess noise in vent piping.
3. Attach combustion air intake piping to supplied 2" coupling on CVI gas valve. Attach vent piping to furnished 2" CPVC vent tee on draft inducer outlet.
4. All pipe joints are to be water tight.
5. Working from boiler to outside, cut pipe to required length(s).
6. Deburr inside and outside of pipe. Remove all chips and shavings.
7. Chamfer outside edge of pipe for better distribution of primer and cement.
8. Clean and dry all surfaces to be joined.
9. Check dry fit of pipe and mark insertion depth on pipe.
10. After pipes have been cut and pre-assembled, apply cement primer to pipe fitting socket and end of pipe to insertion mark. Quickly apply approved cement to end of pipe and fitting socket (over primer). Apply cement in light, uniform coat on inside of socket to prevent buildup of excess cement. Apply second coat.
11. While cement is still wet, insert pipe into socket with ¼ turn twist. Be sure pipe is fully inserted into fitting socket.
12. Wipe excess cement from joint. Continuous bead of cement will be visible around perimeter of properly made joint.
13. Handle pipe joint carefully until cement sets.
14. Support combustion air and vent piping minimum of every 5 feet using pre-formed metal hanging straps. Do not rigidly support pipes. Allow for movement due to expansion and contraction.
15. Slope combustion air and vent pipes toward boiler minimum of ¼" per linear foot with no sags between hangers.
16. Use appropriate methods to seal openings where vent and combustion air pipes pass through roof or side wall.

8 - GAS SUPPLY PIPING

Check Gas Supply

Table 8 - Gas Supply Pressure		
Pressure	Natural Gas	Propane Gas
Minimum	4" w.c.	10" w.c.
Maximum	10" w.c.	14" w.c.

Please check line pressure while unit is running.

- Gas pipe to boiler must be correct size for length of run and total Btuh input of all gas utilization equipment connected to it.
- See Tables 9 and 10 for proper size. Refer to NFPA54 for additional tables.
- Verify your gas line complies with local codes and gas company requirements.

Table 9 - Natural Gas Piping Sizes				
Pipe Length	Pipe Capacity - BTU/Hr. Input ⁽¹⁾			
	1/2"	3/4"	1"	1 1/4"
20'	92,000	190,000	350,000	625,000
40'	63,000	130,000	245,000	445,000
60'	50,000	105,000	195,000	365,000

Table 10 - Propane Gas Piping Sizes				
Pipe Length	Pipe Capacity - BTU/Hr. Input ⁽¹⁾			
	Copper Tubing ⁽²⁾		Iron Pipe	
	5/8"	3/4"	1/2"	3/4"
20'	131,000	216,000	189,000	393,000
40'	90,000	145,000	129,000	267,000
60'	72,000	121,000	103,000	217,000

⁽¹⁾Includes Fittings

⁽²⁾Outside Diameter

Length of pipe or tubing should be measured from gas meter or propane second stage regulator.

Connecting Gas Piping

Refer to Figure 14 for general layout at boiler. Gas line enters boiler through left side panel.

Boiler is equipped with 1/2" NPT connection on gas valve for supply piping and 1/2" NPT ball valve for manual shut off.

Following rules apply:

- Use only those piping materials and joining methods listed as acceptable by the authority having jurisdiction, or in the absence of such requirements, National Fuel Gas Code, ANSI Z223.1/NFPA 54.
- Use pipe joint compound suitable for liquefied petroleum gas on male threads only.
- Use ground joint unions.

- Install sediment trap upstream of gas controls.
- Use two pipe wrenches when making connection to gas valve to keep it from turning.
- Install manual main shutoff valve in vertical pipe about 5 feet (1.5m) above floor outside boiler jacket.
- Tighten all joints securely.
- Propane gas connections made by licensed propane installer.
- Two stage regulation used by licensed propane installer.
- Propane installer to verify Propane gas piping.
- Recommend use 1/2" union suitable for natural and propane gas after ball valve to facilitate service on unit.

Leak Check Gas Piping

Pressure test boiler and gas connection before placing boiler in operation.

Figure 15- Gas Piping

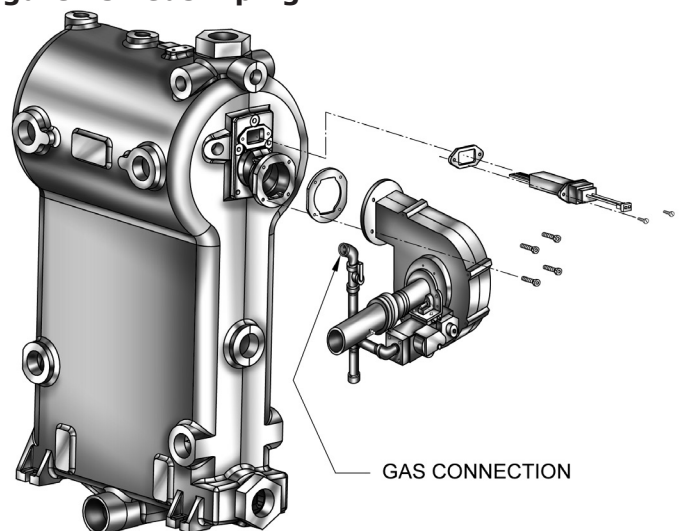

- Pressure test over 1/2 psig (3.5 kPa). Disconnect boiler and its individual gas shutoff valve from gas supply system.
- Pressure test at 1/2 psig (3.5 kPa) or less. Isolate boiler from gas supply system by closing manual gas shutoff valve.
- Locate leakage using gas detector, noncorrosive detection fluid, or other leak detection method acceptable to authority having jurisdiction. Do not use matches, candles, open flames, or other methods providing ignition source.
- Correct leaks immediately and retest.

WARNING

Electrical shock hazard. Turn OFF electrical power supply at service panel before making electrical connections. Failure to do so could result in death or serious injury.

NOTICE

Use copper conductors only.

Electrically bond boiler to ground in accordance with requirements of authority having jurisdiction. Refer to National Electrical Code, ANSI/NFPA 70.

Electric Power Supply

Turn OFF electrical power supply at service panel and boiler before making electrical connections.

- Run 120 volt circuit from separate over current protection device in electrical service entrance panel, 15 ampere circuit.
- Service switch is pre-wired and located on exterior boiler jacket. See Figure 15 for location of service switch, junction box, and power supply connection points.
- Connect black (hot) lead from power supply to either of unused brass screws on service switch.
- Connect white (neutral) lead from power supply to white screw on service switch.
- Connect green (ground) lead from power supply to ground (green) screw on service switch.
- Receptacle on service switch is powered regardless of whether switch is on or off, and could be used as power supply for external condensate pump if one is used.
- Run 14 gauge or heavier copper wire from boiler to grounded connection in service panel or properly driven and electrically grounded ground rod.

Figure 16- Field Wiring Connection

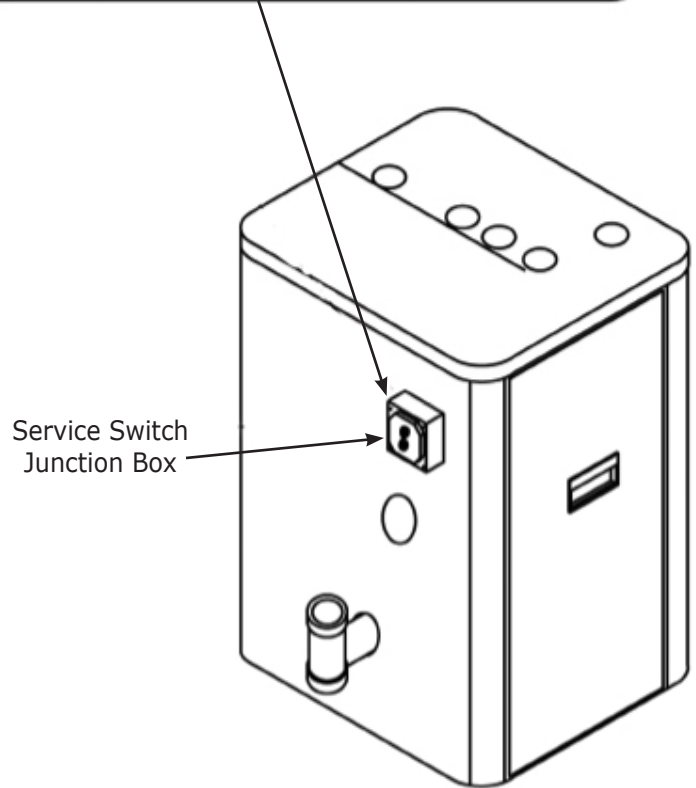
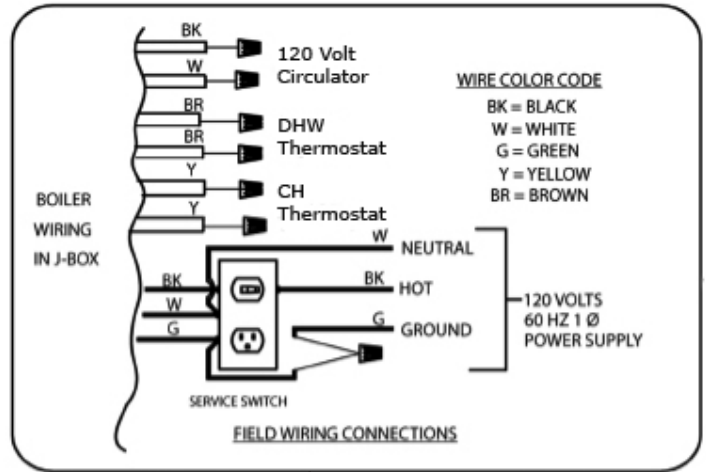

9 - ELECTRICAL WIRING

AVOID THE FOLLOWING	
Dead Spots	Corners Alcoves Behind doors
Cold Spots	Concealed pipes or ducts Stairwells - drafts Unheated rooms on the other side of the wall
Hot Spots	Concealed pipes Fireplaces TVs or radios Lamps Direct sunlight Kitchens

Thermostat Installation

- Follow instructions included with your thermostat.
- Locate thermostat five feet above floor on inside wall.
- Mount directly on wall or vertically mount on outlet box. Thermostat should sense average room temperature.
- Set heat anticipator at 0.7 amps.
- Connect 24 volt thermostat leads to the two (2) yellow wires located in service switch junction box, located on outer jacket of boiler. See Figure 15, Page 22 for service switch junction box and thermostat field wiring connections.

Connect Circulator Pump Wiring

NOTICE

Label all wires prior to disconnection when servicing controls. Wiring errors can cause improper and dangerous operation. Verify proper operation after servicing.

See Figure 16, Page 24 and Figure 17, Page 25 for service switch junction box and circulator pump field wiring connections. If the two 120 volt circulator wire terminals inside junction box are not used, leave two wire nuts to prevent short circuit.

9 - ELECTRICAL WIRING

Figure 17 - Schematic Wiring Connections

NOTE: If any of the original wire as supplied with this appliance must be replaced, it must be replaced with type 150°C Thermoplastic wire or its equivalent.

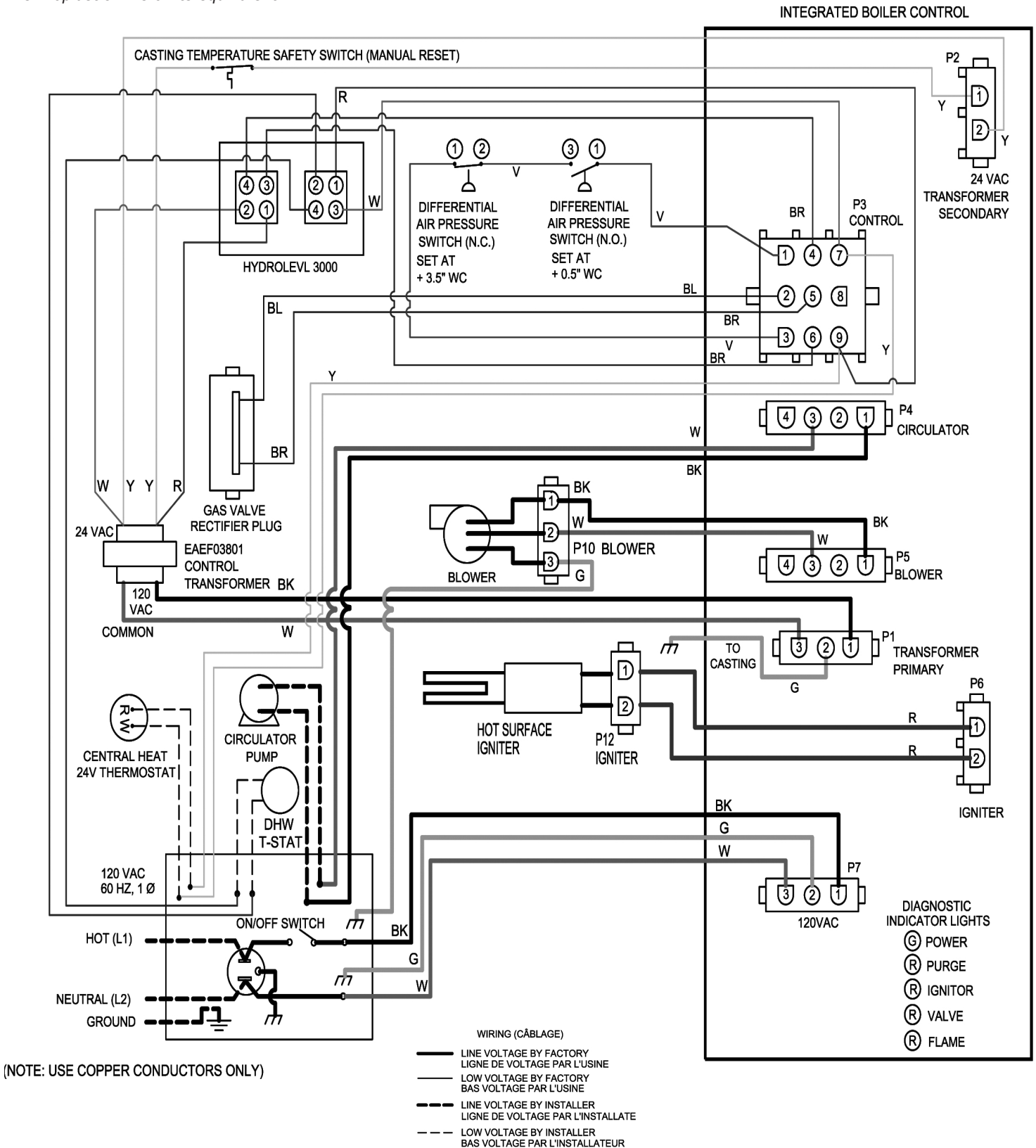

(NOTE: USE COPPER CONDUCTORS ONLY)

9 - ELECTRICAL WIRING

Figure 18- Ladder Wiring Diagram

NOTE: If any of the original wire as supplied with this appliance must be replaced, it must be replaced with type 150°C Thermoplastic wire or its equivalent.

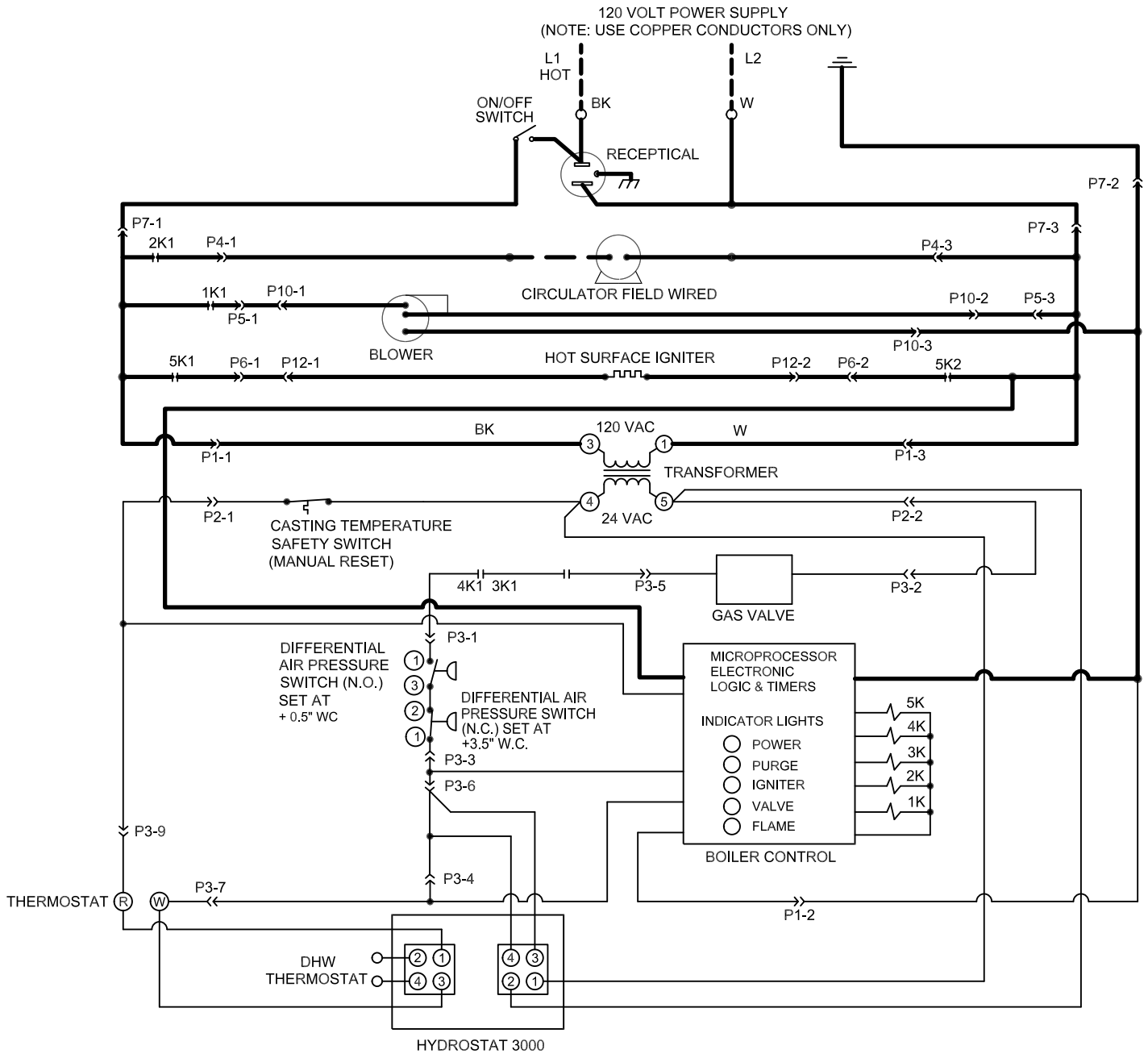

See "Troubleshooting" on page 31 for detailed sequences of operation and troubleshooting procedures. See separately provided "Repair Parts Manual" for locations of control components and accessories described.

Integrated Boiler Control (IBC)

- Integrated Boiler Control (IBC) is a microprocessor based controller for high efficiency gas boilers.
- Controller monitors all safety controls which control operation of combustion air blower, circulator pump, burner, and combination hot surface igniter/flame sensor.
- Controller is not intended for use with vent damper. Controller is mounted on control panel inside boiler. Contains five diagnostic indicator lights.

Gas Control Valve

Electronic 24 volt gas control valve contains 1:1 gas/air pressure regulator, controls gas flow to main burner of appliance. Suited for both natural and LP gas, and rated in accordance with ANSI Z21.21 - latest revision and CGA-6.5-M95.

Figure 19- Gas Valve

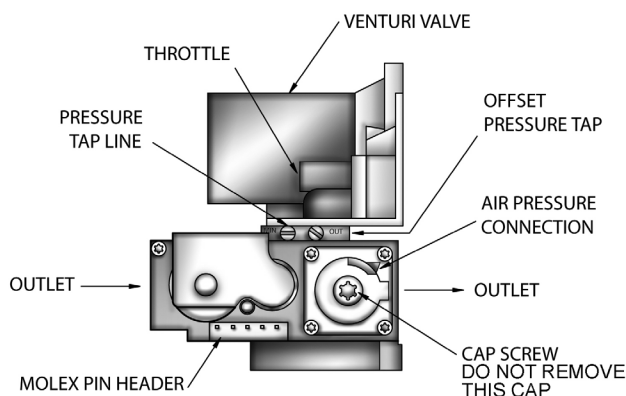

Hot Surface Igniter

- 120 volt hot surface igniter heats up 1800°F initiates combustion of gas in burner.
- Igniter is mounted next to burner through gas/air mixer.
- Igniter also serves as means for proving main burner flame by flame rectification.
 - A. In event of lack of flame signal on three consecutive trials for ignition, IBC will lock out.
 - B. "Valve" and "Flame" diagnostic indicator lamps blink indicating failure mode as lack of flame signal.
 - C. Manually reset IBC from lockout by removing and re-establishing thermostat's call for heat, or turn service switch off, then back on. See Figure 19.

Figure 20- Indicator Lights

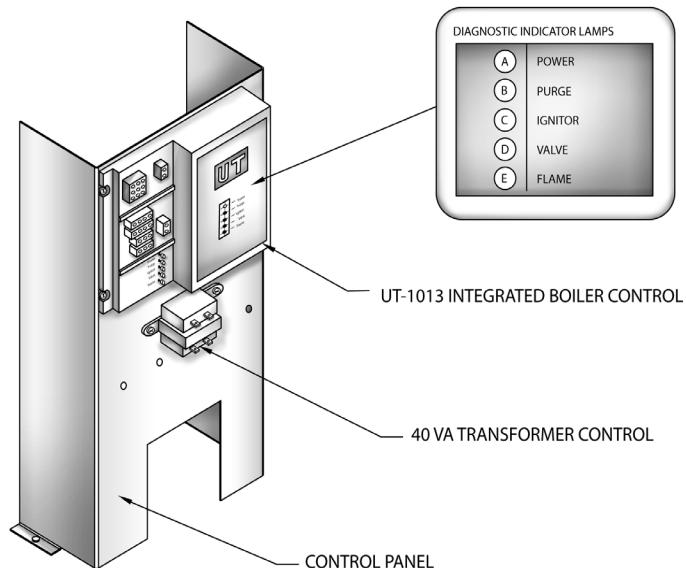

High Limit Control

NOTICE

Maximum set-point of limit control must not exceed 190°F.

- High limit control determines maximum boiler water temperature and provides means for protecting boiler and heating system from unsafe operating conditions which could damage boiler.
- Control is mounted in 1/2" NPT control well and 3/4" x 1/2" bushing on top of front boiler section at hot water outlet.
- Control is tied in with IBC and factory set at 190°F water temperature.
- High limit set-point is field adjustable and may be set between 100°F and 190°F.
- Field set-point adjustment for each installation depends on heating system requirements.
- Differentials are automatic, vary based on control settings and boiler temperature.
- Refer to limit manufacturer instructions provided with limit control.

Casting Temperature Safety Switch

NOTICE

Never run cold water into hot, empty boiler.

Casting temperature safety switch (230°F set-point) shuts off boiler by shutting off power to IBC, result of lack or loss of boiler water. Power indicator light goes out.

Switch is installed on top of aluminum boiler section behind supply piping.

Fault requires manual reset of casting temperature safety switch, restarting boiler. Verify boiler is filled with water before resetting switch.

Differential Pressure Switches

- Diaphragm type differential pressure switches are connected by vinyl tubing to gas valve, air inlet connection on negative side, and sight glass adapter on positive side. Pressure switches monitor air flow by sensing differential pressure measured in inches of water (" w.c.).
- Switch factory settings are 0.5" w.c. on normally open switch and 3.5" w.c. for normally closed switch.
- See pages 31-32, "Detailed Sequence of Operation," for details.

Blower

Blower provides means for pushing combustion air into and through mixer, burner, and flue ways of cast aluminum boiler section before being discharged through vent piping to outdoors.

Circulator Pump

- Forced hot water system requires at least one circulating pump.
- Circulating pump provides energy to move water through closed loop supply, return piping systems, terminal heating equipment (finned tube radiators, etc.) and back through boiler for reheating.
- To provide required hot water flow rates, circulator pump must be properly sized to overcome frictional losses (usually measured in feet of water, also referred to as "pump head loss") of supply and return piping systems and boiler.
- Circulator pump is furnished in a carton within boiler cabinet. Locate circulator(s) on downstream (i.e., "pumping away") side of expansion tank.

Drain Valve

Manual drain valve is means of draining water in heating system, including boiler, hot water supply and return piping systems installed above drain valve.

Install drain valve in $\frac{3}{4}$ " tapping at bottom of boiler.

Piping installed below drain valve elevation requires additional drain valves installed at low points in piping systems to drain entire system.

WARNING

Burn and scald hazard. Safety relief valve could discharge steam or hot water during operation. Install discharge piping per these instructions.

A.S.M.E. Rated Pressure Relief Valve

- Each boiler must have properly sized and installed A.S.M.E. rated pressure relief valve.
- Water expands as it is heated by the burner/boiler sections. If no place for water to expand its volume, (i.e., properly sized functioning expansion tank) pressure inside of boiler and heating system increases.

- Furnished relief valve automatically opens at 30 psi to relieve strain on boiler and heating system from increasing pressure.
- Pipe pressure relief valve discharge with same size as valve discharge opening to open drain, tub or sink, or other suitable drainage point. Do not subject to freezing, in accordance with A.S.M.E.
- Failure to provide pressure relief valve with piping as described may cause water damage and/or serious bodily injury.

Blocked Vent Safety Shutoff

- Boiler equipped with blocked vent safety shutoff, shuts off main burner gas in event airflow of combustion products through flue-way is reduced.
- Air will not be available to support combustion if flue-way is blocked. IBC locks out due to loss of adequate air flow.
- Pressure switches monitor air flow by sensing differential pressure. Contacts normally open and close when draft inducer is running causing differential pressure at switch to exceed settings. Closed switch proves adequate air flow for combustion.
- Pressure switch shuts off main burner if differential pressure is inadequate due to blocked vent pipe, blocked air intake, blocked boiler section, or blocked air inducer. After 5 minutes of inadequate differential pressure, IBC will lock out.
- "Purge" indicator lamp blinks, see Figure 19, Page 26, indicating failure to prove adequate combustion air flow or flue gas flow. IBC automatically resets after 15 minutes or manually reset as noted see "C" page 26. Boiler cannot be restored to normal operating condition by resetting control, contact qualified service agency to check heat exchanger flue-ways for blockage.

High Limit /Low Water Cut Off

Unit equipped with high limit low water cut off control, protects against over temperature and dry firing. Control provides burner cut off if unsafe water loss, which can result from broken or leaking radiator, pipe, or boiler. Use water/glycol mixture 50% with low water cut off. Refer to manufacturer provided literature for specific features.

External Condensate Pump (Optional)

Installations where no floor drain or other appropriate drainage available, external float activated condensate pump with integral sump (not supplied) is required.

May pipe condensate pump to remote tie in point to sanitary sewer system. For this application, boiler must be installed so proper pitch of piping to external condensate reservoir (sump) can be accomplished. Use wood frame or blocks to raise boiler as required for proper installation.

Water Treatment And Freeze Protection

Filling Boiler With Water And Purging Air For Systems With Diaphragm Type Expansion Tanks

Refer to the appropriate diagrams "Near Boiler Piping" on pages 10 and 11.

1. Close all zone service valves on supply and return piping. Open feed valve and fill boiler with water. Verify air vent is open. Hold relief valve open until water runs air free for five seconds to rapidly bleed air from boiler, let relief valve snap shut.
2. Open zone service valve on **supply** pipe for first zone. Open purge valve on first zone. Feed water fills zone, pushing air out purge valve. Close purge valve when water runs air free. Close zone service valve.
3. Repeat step 2 for all remaining zones.
4. Open all service valves. Any air remaining trapped in return lines between service valves and boiler are pushed towards air vent when boiler is placed in operation.
5. Inspect piping system. Repair any leaks immediately.

NOTICE

Do not use stop leak compounds or other chemicals not listed in this manual. Repair leaks in threaded connections of aluminum boiler sections. Aluminum threads do not seal themselves.

6. Systems with automatic fill valves and leaks will cause excessive fill water. This water contains oxygen. Excessive oxygen will cause the aluminum boiler to corrode over time. All system leaks should be repaired immediately.

Filling Boiler With Water And Purging Air For Systems With Conventional Closed Type Expansion Tanks

Refer to diagrams on "Near Boiler Piping" on pages 9 and 10 for more information.

1. Close all zone service valves on supply and return piping. Close expansion tank service valve. Drain expansion tank. Open feed valve and fill boiler with water. Hold relief valve open until water runs air free for five seconds to rapidly bleed air from boiler, let relief valve snap shut.
2. Open zone service valve on supply pipe for first zone. Open purge valve on first zone. Feed water will fill zone, pushing air out purge valve. Close purge valve when water runs air free. Close zone service valve.
3. Repeat step 2 for remaining zones.
4. Open expansion tank service valve and tank vent. Fill tank to proper level and close tank vent. Remove handle from expansion tank service valve so homeowner doesn't accidentally close it.
5. Open all service valves. Any air remaining trapped in return lines between service valves and boiler will push towards expansion tank when boiler is placed in operation.
6. Inspect piping system. Repair any leaks immediately.

⚠ WARNING

If you do not follow these instructions exactly, a fire or explosion may result causing property damage, personal injury or loss of life.

- This appliance is equipped with an ignition device which automatically lights burner. **Do NOT try to light this burner by hand.**
- Before operating smell all around appliance area for gas. Be sure to smell next to floor because some gas is heavier than air and will settle to the floor.
- **Use only your hand to turn the gas shutoff valve.** Never use tools. If valve will not turn by hand, do not try to repair it, call a qualified service technician. Force or attempted repair may result in fire or explosion.
- **Do not use this appliance if any part has been under water.** Immediately call a qualified service technician to inspect appliance and to replace any part of control system and any gas control which has been under water.

LIGHTING PROCEDURE FOR BOILER WITH INTERMITTENT PILOT SYSTEM

1. This appliance is equipped with an ignition device which automatically lights the pilot. Do not try to light the appliance by hand.

⚠ CAUTION**WHAT TO DO IF YOU SMELL GAS**

- Do not try to light any appliance.
- Do not touch any electrical switches; do not use any phone in your building.
- Immediately call your gas supplier from a neighbor's phone. Follow the gas supplier's instructions.
- If you cannot reach your gas supplier, call the fire department.

Operating Instructions

1. **STOP!** Read the safety information on this page before operating this appliance.
2. Set the thermostat to the lowest setting.
3. Turn off all electrical power to the appliance.
4. This appliance does not have a pilot. It is equipped with an ignition device which automatically lights the burner. Do NOT try to light this burner by hand.
5. Remove the front jacket panel.
6. Turn off the gas shut off valve. Valve handle should be perpendicular to the gas pipe.
7. Wait five minutes for any gas to clear. Then smell for gas, including near the floor. If you smell gas, **STOP!** Follow instructions at left under "*What To Do If You Smell Gas.*" If you do not smell gas, go to the next step.
8. Turn the gas shut off valve to the "On" position. The handle on the valve should be parallel to the gas pipe.
9. Replace the front jacket panel.
10. Turn on all electrical power to the appliance.
11. Set thermostat to desired setting.
12. If the appliance will not operate, follow instructions in "**To Turn Off Gas To Appliance**" (below) and call your service technician or gas supplier.

To Turn Off Gas To Appliance

1. Set thermostat to lowest setting.
2. Turn off all electric power to appliance if service is to be performed.
3. Remove the front jacket panel.
4. Turn gas shut off valve off. Handle should be perpendicular to the gas pipe.
5. Replace the front jacket panel.

Safe lighting and other performance criteria were met with gas manifold and control assembly provided on boiler when boiler underwent tests specified in ANSI Z21.13-latest revision.

If Burner Appears To Pulsate During Ignition:

1. Turn off boiler power. Shut off gas supply to boiler.
2. Take burner assembly apart by removing combustion air blower and gas valve/venturi assembly from boiler. Visually inspect inside of burner. Look for debris (PVC shavings, etc.). Remove debris if present.
3. Reassemble burner assembly, turn gas supply and boiler power back on, relight boiler.

If Burner Continues To Pulsates Or Fails To Light:

1. Check for proper vent, intake pipe sizing, proper vent lengths and vent configuration. Refer to "Safe Installation And Operation" on page 6 and "Combustion Air/ Vent Requirements" on page 16.
2. Check for proper gas supply pressure and proper gas line sizing to boiler. Refer to "Check Gas Supply" on page 22.
3. Check for orifice in negative pressure hose at gas valve, and 2" air intake pipe upstream of gas valve.
4. Relight boiler.
5. If boiler still does not light,
 - A. Disconnect air inlet pipe. Allow boiler to start, verify boiler firing rate and combustion properties.
 - B. Disconnect inlet air pipe by removing PVC inlet air piping from coupler located on air inlet of gas valve/venturi assembly.
 - C. Relight boiler.
6. Verify firing rate and combustion when boiler lights. Refer to "Adjustments And Checkout" on page 35. If air inlet piping was disconnected in step 4 (above), leave it disconnected and make first adjustment. Reconnect air inlet piping, then verify combustion CO_2 , adjust again if necessary.
7. If burner pulsation continues or boiler fails to light after performing above procedures, contact technical service for assistance.

12 - DETAILED SEQUENCE OF OPERATION

DRAFT INDUCER TEMPERATURE SAFETY SWITCH

If draft inducer temperature reaches temperature safety switch set-point, safety switch contacts open immediately, closing gas valve (**light goes out**).

Draft inducer runs through 30 second post purge and switches OFF.

Circulator runs with thermostat on call for heat.

When temperature safety switch contacts connect before end of call for heat, control goes in normal light-off sequence.

LOSS OF FLAME SIGNAL

If established flame signal is lost while control expects burner is operating, control immediately de-energizes gas valve.

Valve and flame lights go out.

Draft inducer runs through 30 second post purge.

Control attempts to light boiler 3 times. If flame is not proven, control lockout problem establishing flame signal.

Valve light is blinking.

Control automatically resets after 1 hour.

LOSS OF COMBUSTION AIRFLOW

If combustion airflow is lost while burner is firing (Differential air pressure switch contacts open) gas valve is de-energized.

Valve and flame lights go out.

Draft inducer runs through 30 second post purge.

If call for heat remains, IBC waits 5 minutes for airflow to be re-established.

If airflow does not re-establish control lockout problem with combustion airflow.

Purge light blinks.

Control automatically reset after 15 minutes.

CASTING TEMPERATURE SAFETY SWITCH

If burner operates when boiler has no water, aluminum boiler sections heat up rapidly.

Casting temperature safety switch contacts will open, breaking 24 volt power to IBC. Power indicator light goes out.

Requires manual reset to re-close contacts.
Power light goes out.

HIGH LIMIT CONTROL [REFER TO PAGE 37 FOR MORE INFO]

If boiler water temperature reaches high limit setpoint, high limit n.c. contacts open immediately, closing gas valve.

Valve and flame lights go out.

Draft inducer continues to run for 30 second post purge and switch OFF.

Circulator runs as long as thermostat calls for heat.

When high limit contacts connect before end of call for heat - control goes into normal light-off sequence.

CIRCULATOR PUMP

Circulator is energized as long as thermostat calls for heat during lockout.

Recovery from any lockout requires reset, which can be accomplished by:

- (a) Removing and re-establishing thermostat's call for heat or turning service switch off and back on;
or
- (b) Waiting for control to automatically reset after 15 minutes for loss of combustion airflow or one hour for loss of flame.

End Of Normal Sequence Of Operation

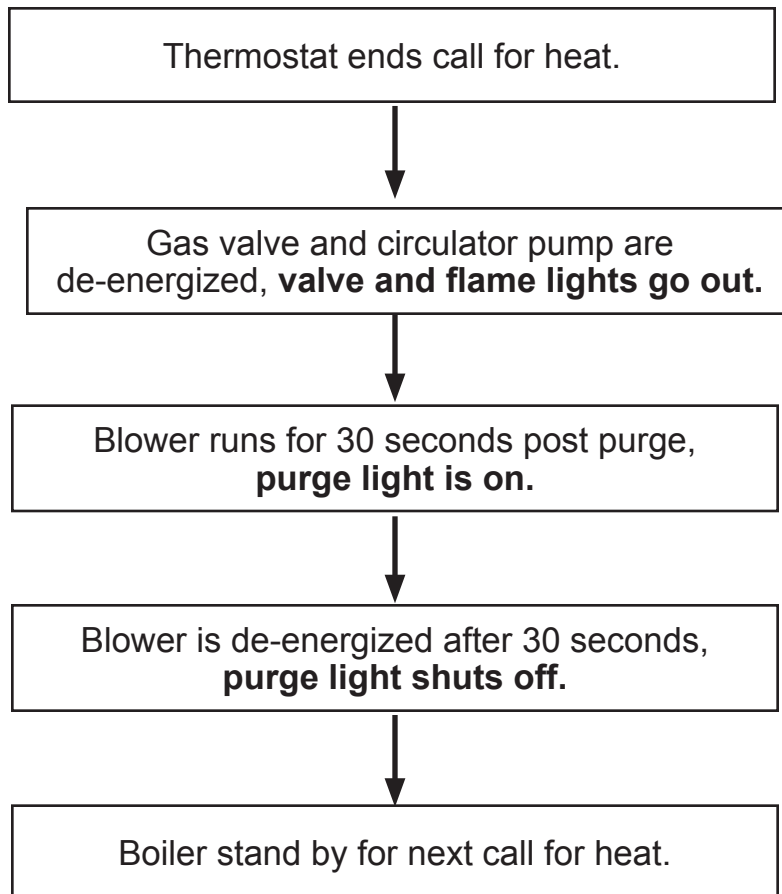

12 - DETAILED SEQUENCE OF OPERATION

SERVICE HINTS

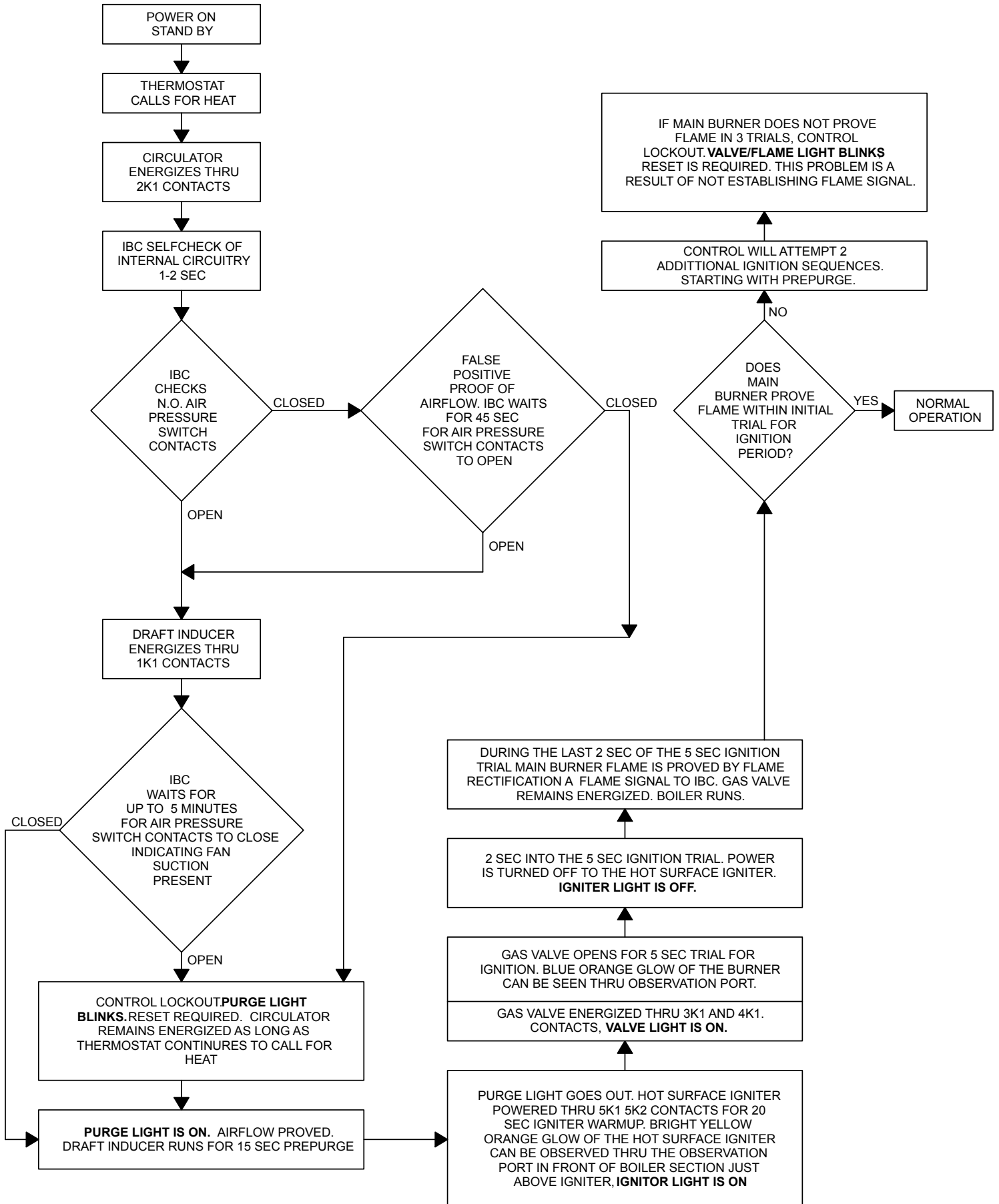

13 - SEQUENCE OF OPERATION DIAGNOSTICS

Sequence Of Operation Diagnostics

Follow sequence using the diagnostic indicator lamps on Integrated Boiler Control (IBC). See "Controls And Accessories" on page 26 for normal sequence of operation. Detailed sequence of operation containing potential faults can be found in service hints section.

SEQUENCE OF OPERATION	DIAGNOSTIC INDICATOR LAMPS	
(1) Lamp A is illuminated, indicating integrated control is receiving 24 volts and is in standby waiting for thermostat call for heat. (2) Thermostat calls for heat, energizing system circulator. (3) Integrated boiler control performs self check of internal circuitry, approximately two seconds, energizing draft inducer.	A. B. C. D. E.	● ○ ○ ○ ○
(4) Draft inducer comes up to speed and establishes combustion airflow, causing normally open differential pressure air proving switch contacts to close. When combustion airflow is proved, Lamp B illuminates indicating 15 second pre-purge cycle has begun.	A. B. C. D. E.	● ● ○ ○ ○
(5) After pre-purge completion, Lamp B is extinguished and Lamp C is illuminated, indicating power is being delivered to hot surface igniter for 20 second igniter warm-up period. Observe bright yellow-orange glow of hot surface igniter through observation port on boiler.	A. B. C. D. E.	● ○ ● ○ ○
(6) After igniter warm-up period, integrated boiler control energizes gas valve, initiating 6 second trial for ignition mode, indicated by illumination of Lamp D. Lamp C extinguishes after 2 second delay. Integrated boiler control stops sending power to hot surface igniter.	A. B. C. D. E.	● ○ ● ● ○
(7) Low level illumination of Lamp E indicates initiation of flame proving. During last 2 seconds of trial for ignition mode, main burner flame is proven by flame rectification through hot surface igniter, providing flame signal is relayed to integrated boiler control, fully illuminating Lamp E.	A. B. C. D. E.	● ○ ○ ● ●
(8) Thermostat ends its call for heat. Integrated boiler control de-energizes gas valve and system circulator. Lamp D is extinguished while unit enters 30 second post purge mode, indicated by illumination of Lamp B. Lamp E will remain illuminated as remainder of gas in blower is burned off (approximately 2 seconds). During post purge blower remains powered and clears out any residual products of combustion.	A. B. C. D. E.	● ● ○ ○ ○
(9) After post purge mode draft inducer is de-energized. Unit goes into standby mode until next call for heat from thermostat.	A. B. C. D. E.	● ○ ○ ○ ○

NOTE: First one or two cold starts may be rough due to gas line not being completely purged of air, causing low firing rate and high excess air levels.

13 - SEQUENCE OF OPERATION DIAGNOSTICS

System Status

Indicator lights track operating sequence. If system locks out, lights indicate point in sequence of operation where lockout occurs. Refer to following pages for detailed troubleshooting procedures.

LIGHT	STATUS	INDICATES
POWER	ON	IBC is energized through 24 volt transformer.
	OFF	IBC is not energized.
	Blinking	IBC receives more than 40 VAC.
PURGE	ON	IBC is energizing draft inducer and air flow is proven.
	OFF	Off during purge cycle - draft inducer is not powered on or air flow is not proven.
		Off during igniter and run cycle - normal operation, purge cycle complete.
Blinking	IBC is locked out. Problem could indicate false positive proof of air flow. Blocked vent, intake air pipe, flue way, or orifice in negative pressure hose.	
IGNITER	ON	IBC is energizing igniter.
	OFF	Igniter is not energized.
VALVE	ON	IBC is energizing gas control valve to open.
	OFF	Gas control valve is closed.
	Blinking	IBC is locked out. Problem is flame has not been proven in three (3) ignition attempts. May be due to broken igniter or lack of/low flame signal, or no gas.
FLAME	On Bright	Flame proven.
	On Dim	Checking for flame signal (during trial for ignition)
	OFF	Flame unproven.

14 - CHECKOUT PROCEDURE & ADJUSTMENTS

Inspect Venting & Air Intake System - Operate boiler. Verify all vent/air intake connections are gas-tight and water-tight. Repair any leaks immediately.

Inspect Condensate Drain - Verify all connections are watertight, and condensate flows freely. Repair any leaks immediately.

Inspect System Piping - Verify all connections are watertight. Repair any leaks immediately.

Test Ignition System Safety Shutoff

1. Turn off manual gas shut off valve.
2. Set thermostat to call for heat.
3. Boiler begins normal sequence of operation.
4. After approximately 30 seconds (pre-purge and igniter warm-up period), lamp D illuminates, indicating gas valve is powered.
5. After 4 seconds, gas valve closes, lamp D goes out as integrated boiler control senses flame is not present.
6. To restart system, follow operating instructions. See "Startup" on page 29.

Test And Adjust High Limit Control

- At initial start up, with Economy Feature activated, control establishes 145°F target temperature.
- While burner is operating, adjust setting on high limit control below actual boiler water temperature.
- Burner should go off while circulator continues to operate.
- Raise limit setting above boiler water temperature and burner should re-ignite after pre-purge and igniter warm-up period.
- Set high limit control to design temperature requirements of system.
- Maximum high limit setting is 190°F.
- Minimum high limit setting is 100°F.
- After testing, restore Economy setting. If heating demand is high, target will increase over time to satisfy heat load.
- See Manufacturer provided literature for specific features of high limit control.

Test Other Safety Controls

If boiler is equipped with low water cut off, manual reset high limit, or additional safety controls, test for operation as outlined by control manufacturer.

Burner should be operating and should go off when controls are tested.

When safety controls are restored, burner should re-ignite.

Set Thermostat Heat Anticipator (If Used) And Verify Thermostat Operation

- Set heat anticipator at 0.7 amps for single thermostat connected to yellow thermostat lead wires in furnished field wiring junction box.
- For other wiring configurations, refer to instructions provided by thermostat manufacturer regarding adjustment of heat anticipator.
- Cycle boiler with thermostat.
- Raise thermostat to highest setting.
- Verify boiler goes through normal start up cycle.
- Lower thermostat to lowest setting and verify boiler shuts off.

Measure Natural Gas Input Rate

Correct input rate is essential for proper and efficient operation of burner and boiler.

1. Determine elevation at installation site.
2. See "Boiler Ratings & Capacities" on page 4. to determine correct approximate input rate for local elevation.
3. Obtain yearly average heating value of local gas utility. At sea level elevation, approximately 1000 BTU per standard cubic foot.
4. Operate boiler for 5 minutes.
5. Turn off all other gas appliances, extinguishing standing pilots where applicable.
6. At gas meter, measure time in seconds required to use one cubic foot of gas.
7. Calculate "input rate". Refer to following formula:

$$\text{Btuh Input Rate} = \frac{3600 \times \text{Heating Value From Step 3}}{\text{Time In Seconds From Step 6}}$$

8. Measured input rate should be within +0/-2% of input rating found in step 2. See "Adjustments And Checkout" on page 36.

Adjustments And Checkout

Appliance should operate between 8.5 And 10% CO₂. Verify boiler is operating in this range. Follow steps below.

NOTICE

Under all conditions CO levels should not exceed 100ppm.

1. Check incoming gas pressure to appliance using pressure gauge with resolution of 0.1" w.c. or better and range from 0" to at least 14" w.c.
 - A. Close gas shut-off inside boiler jacket.
 - B. Locate inlet pressure tap on gas valve. Figure 18, Page 26.
 - C. Open inlet pressure tap screw ½ turn. Connect positive side of pressure gauge to inlet pressure tap.
 - D. Open gas shut-off.
 - E. Gas pressure
 - between 4" and 10" w.c. natural gas
 - between 10" and 14" w.c. propane gas.
2. Drill hole in plastic CPVC pipe for combustion analyzer.
3. Turn thermostat to closed position to activate boiler.
4. Allow boiler to run for 5 minutes.
5. Insert combustion analyzer sample probe into hole just drilled, about halfway into exhaust gas stream.
 - A. Take flue gas reading and observe CO₂ value.
 - B. Adjust throttle screw until CO₂ value is between 8.5 And 10%. (O₂ between 5.5% and 2%)
 - C. Turning throttle screw counter clockwise increases rate and CO₂ value.
 - D. Turning throttle screw clockwise decreases rate and CO₂ value.
 - E. Allow boiler to stabilize for 1 minute after adjusting throttle screw before taking reading with combustion analyzer.
6. After adjustments are made stop appliance. Disconnect pressure gauge. Tighten inlet pressure tap on gas valve, remove CO₂ meter from CPVC pipe.
7. Seal hole in CPVC pipe with appropriate material.
8. Return thermostat switch to its original position.

Installation Final Checkout

After any adjustment to boiler, observe several complete cycles to ensure all components function correctly.

Set Thermostat To Desired Temperature

Set thermostat to desired room temperature and observe several complete cycles to verify proper operation.

Final Review And Sign-Off

Review all instructions shipped with this boiler with owner or maintenance person. Affix instructions on or adjacent to boiler.

High Limit Control and LWCO

LED Legend and LWCO Test Button

1 **HI TEMP** illuminates when boiler water temperature reaches high limit setting. Remains lit until water temperature falls 10°F. Limit prevents burner operation while this LED is on.



2 **LWCO ACTIVE** Indicates low water cut-off function is active. When control is installed with Electro-well, LED is on at all times when control is powered. If the control is installed with a well other than Electro-well, LED will not illuminate indicating the control is not providing low water cutoff functionality.

WARNING

Burn and scald hazard. Do not add water until boiler has fully cooled. Failure to follow these instructions could result in death or serious injury.



3 **LWCO LOW WATER** Illuminates if boiler is in low water condition. Control will prevent burner operation during this condition.

Important: System must be checked by qualified service agency prior to resuming operation.



4 **ECONOMY ACTIVE** Indicates that thermal targeting function is active and control reduces boiler temperature to conserve fuel. Economy feature is activated using the ECONOMY dial.



5 **ECONOMY TARGET** When feature is active, control continually sets target temperatures below high limit setting to maximize fuel efficiency. When boiler reaches target temperature, LED illuminates and burner shuts down. Boiler water continues to circulate and heat the house as long as thermostat call continues. LED stays lit until boiler temperature drops below differential at which point boiler will be allowed to fire again.

Note: LED illuminates regularly during normal boiler operation.

6 **PURGE** Control is purging latent heat from boiler and will not fire until temperature drops to 135°F.

7 **LWCO** To Test LWCO: Press and hold TEST button. Red Low Water light will illuminate and burner circuit will de-energize.

Figure 21- LED Legend

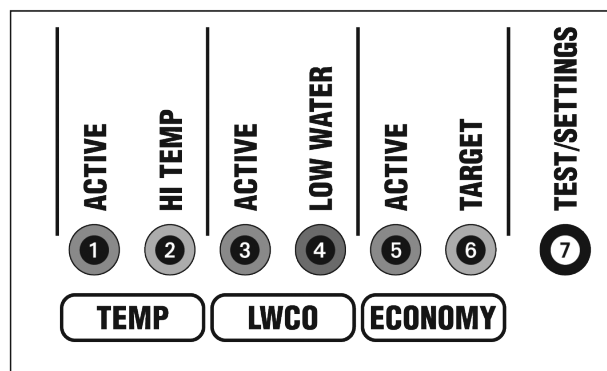

15 - TROUBLESHOOTING

Troubleshooting Flow Chart - High Limit Control And LWCO

Burner Will Not Fire	See Flow Chart, this page.
No or Insufficient Domestic Hot Water	If installed with indirect water heater, insure end switch in relay box controlling indirect water heater is properly connected to Cable 2. This will insure domestic water calls are prioritized. If Cable 2 is not used, turn Economy Feature OFF.
House Will Not Get or Stay Warm	<ol style="list-style-type: none"> 1. Check for air-bound radiators. 2. Check thermostat settings including heat anticipator settings (common on non-digital thermostats). 3. Check Economy setting. Economy feature, like outdoor reset controls, lowers average boiler temperature and can slow or, in some cases, prevent the house from coming up to temperature. Move to lower setting.

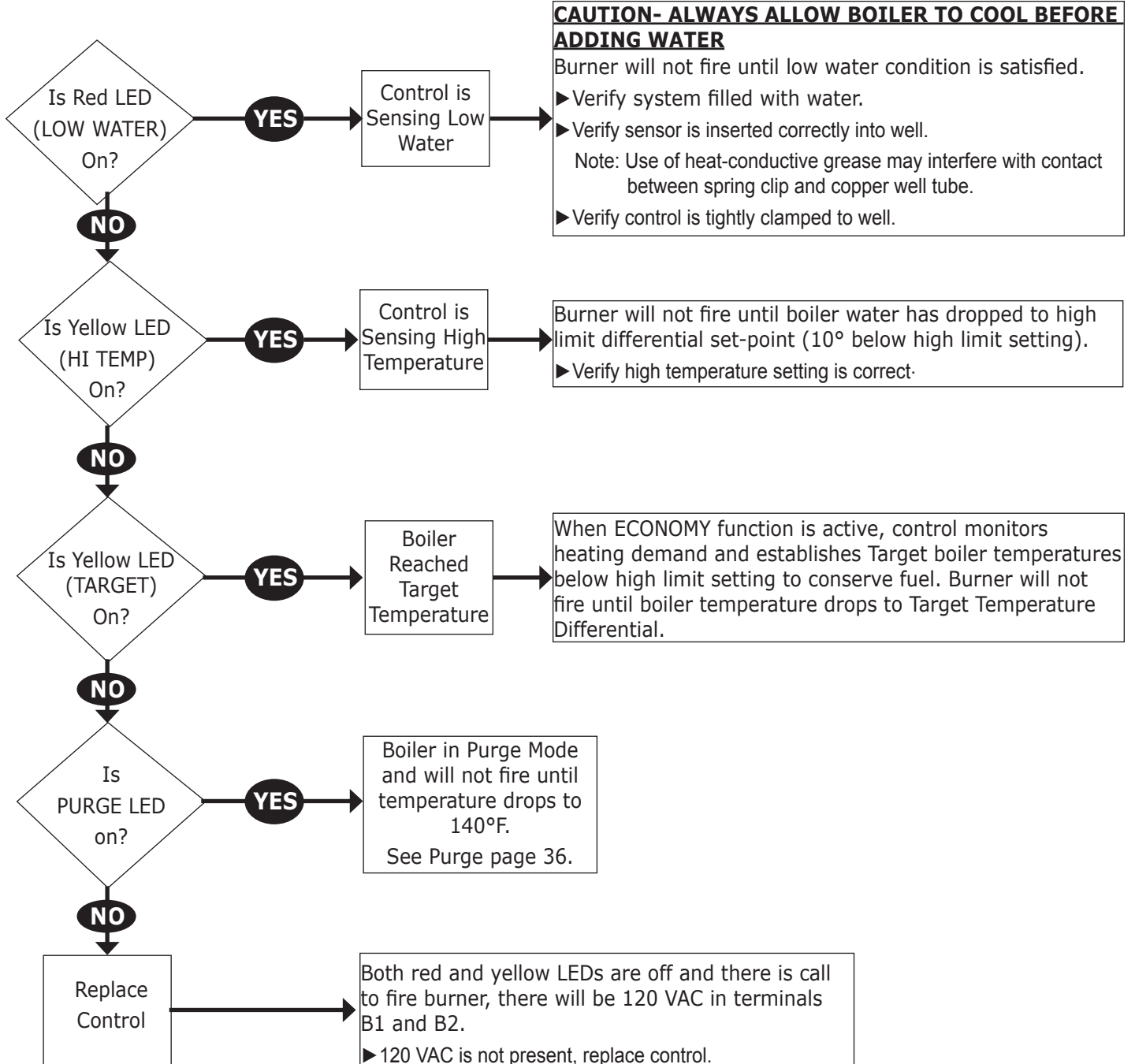

⚠ WARNING

Fire, explosion or shock hazard may cause death or serious injury. Do not attempt to modify physical or electrical characteristics of this boiler in any way.

- In reset from lockout condition, all electrical meter readings at gas control valve (24 vac) must be taken within trial for ignition period.
- If any component does not function properly, make sure it is correctly installed and wired before replacing.
- Static electricity discharge can damage integrated boiler control (IBC). Touch metal surface to discharge static electricity before touching IBC.
- IBC cannot be repaired. If it malfunctions it must be replaced.
- Only trained, experienced service technicians should service IBC systems. Follow troubleshooting to check out system and sequence of operation for normal light off sequence.
- Defective control is least likely cause of malfunction. If you suspect unit has defective control, read through troubleshooting chart before replacing it.
- It is unlikely two consecutive controls are defective. If this seems to be the case chances are the controls are not the cause but rather malfunction is due to some other problem such as electrical short burning out transformer.

Initial Service Checks

1. Before Troubleshooting:
 - A. Verify circuit breaker is on or fuse is OK at electrical panel.
 - B. Verify service switch is ON.
 - C. Verify Gas is ON at:
 - Gas meter
 - Appropriate manual shutoff valves
 - Gas control valve
 - D. Verify thermostat is calling for heat.
 - E. Verify wire connections at integrated boiler control (IBC) and originating control are securely plugged in or connected.
 - F. Check hoses are securely connected and are not plugged or damaged.
2. Troubleshooting Tools:
 - A. Voltmeter to verify 120 VAC and 24 VAC
 - B. Continuity Tester
 - C. Inclined Manometer or Pressure Gauge with 0-2.0" range (0.01" scale) for measuring suction pressures at pressure switch.
 - D. U-Tube Manometer or Differential Pressure Gauge with 0-14" range (0.1" scale) for measuring inlet and manifold gas pressures.
3. System Status:
 - A. Consult "System Status" on page 40.
 - B. See Figure 19, Page 26, for location of boiler Diagnostic Indicator Lamps.

Troubleshooting Chart 1

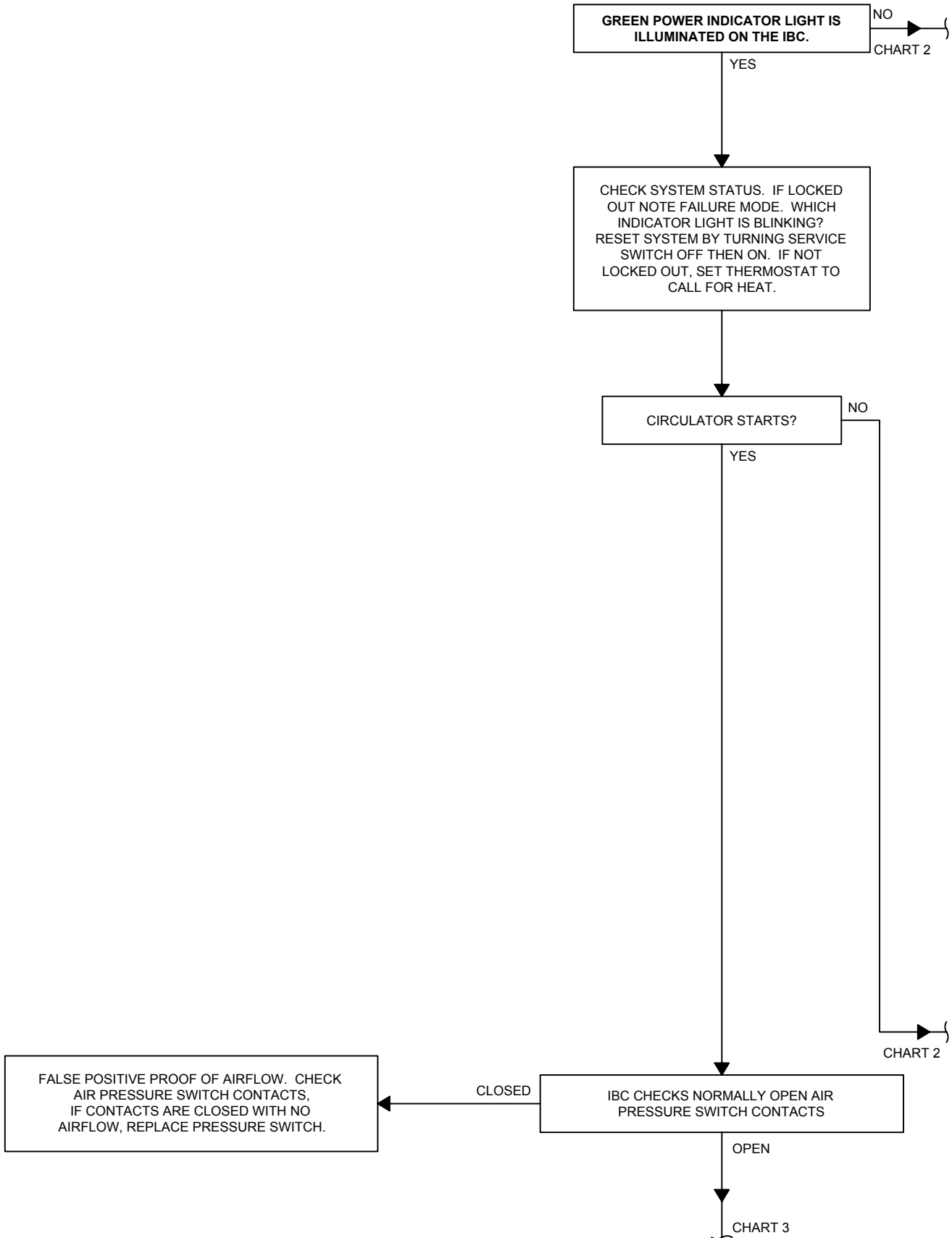

Troubleshooting Chart 2

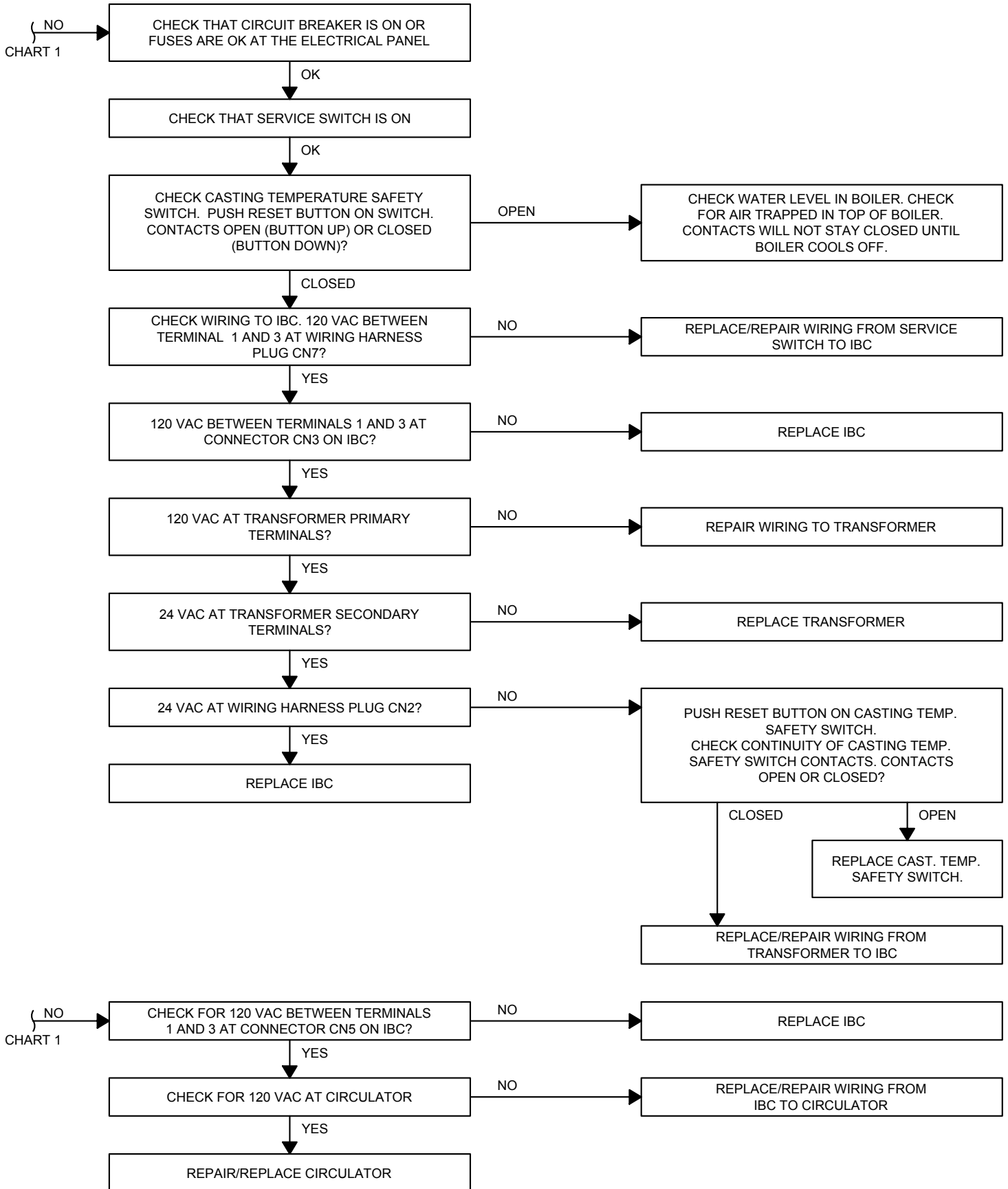

Troubleshooting Chart 3

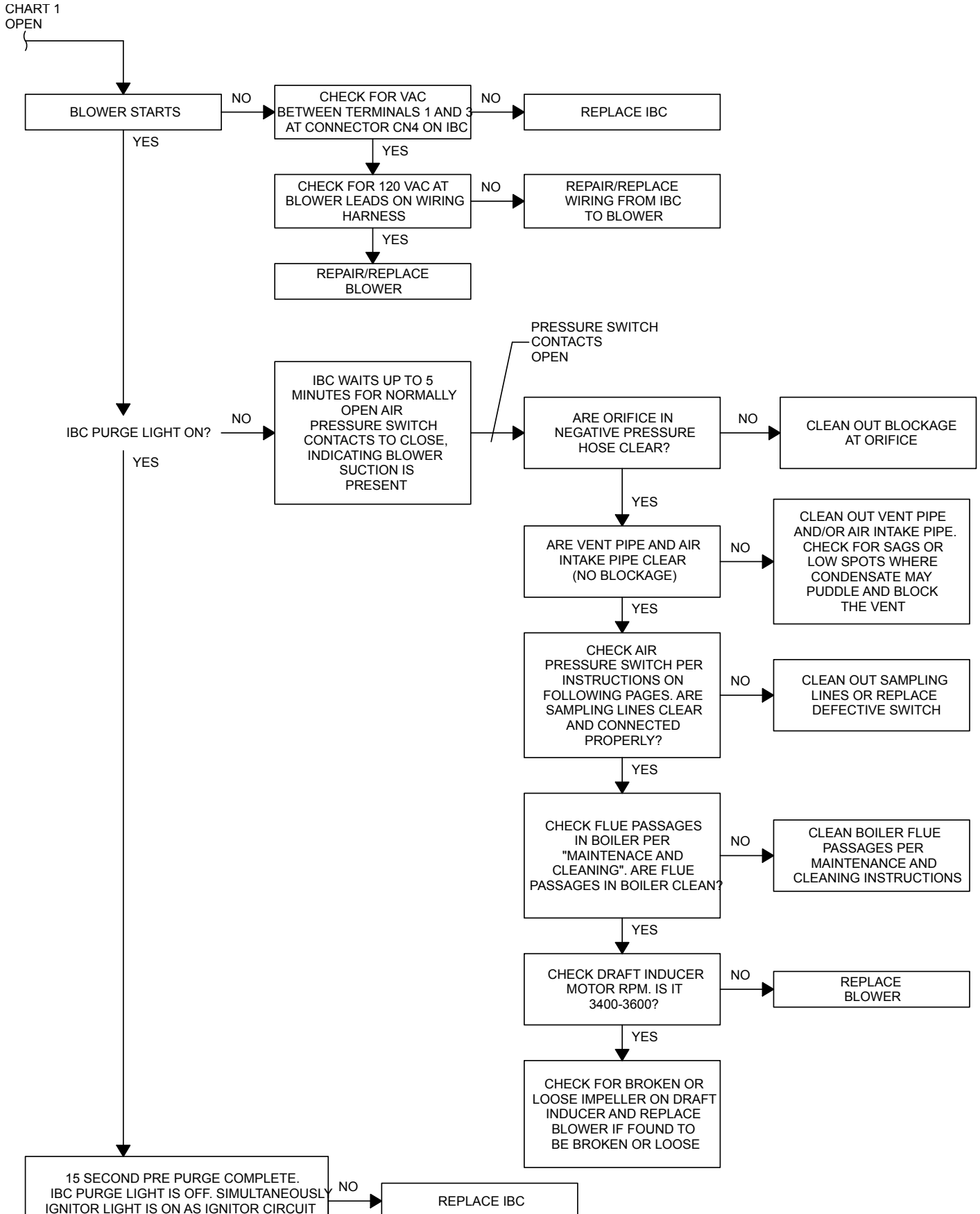

Troubleshooting Chart 4

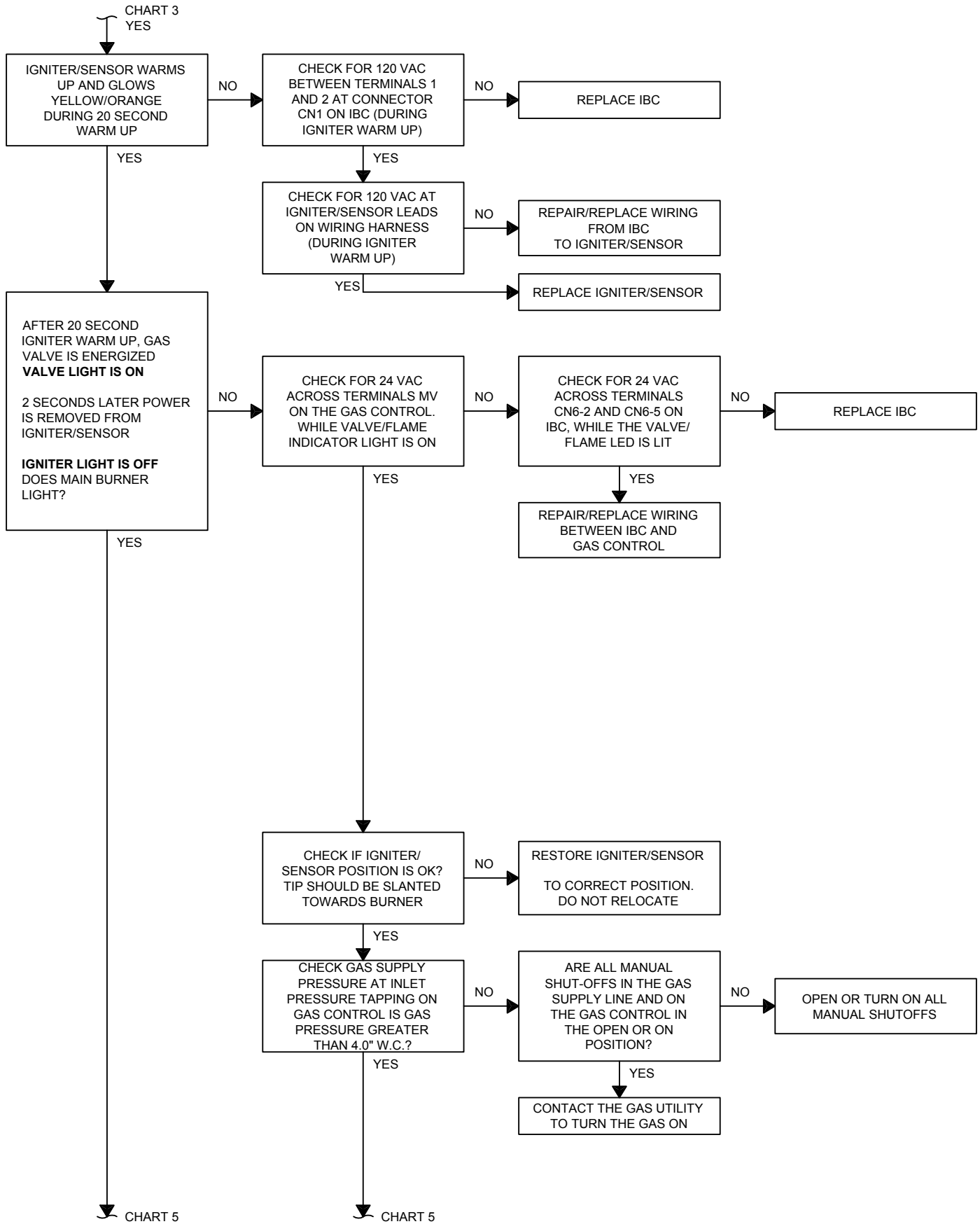

Troubleshooting Chart 5

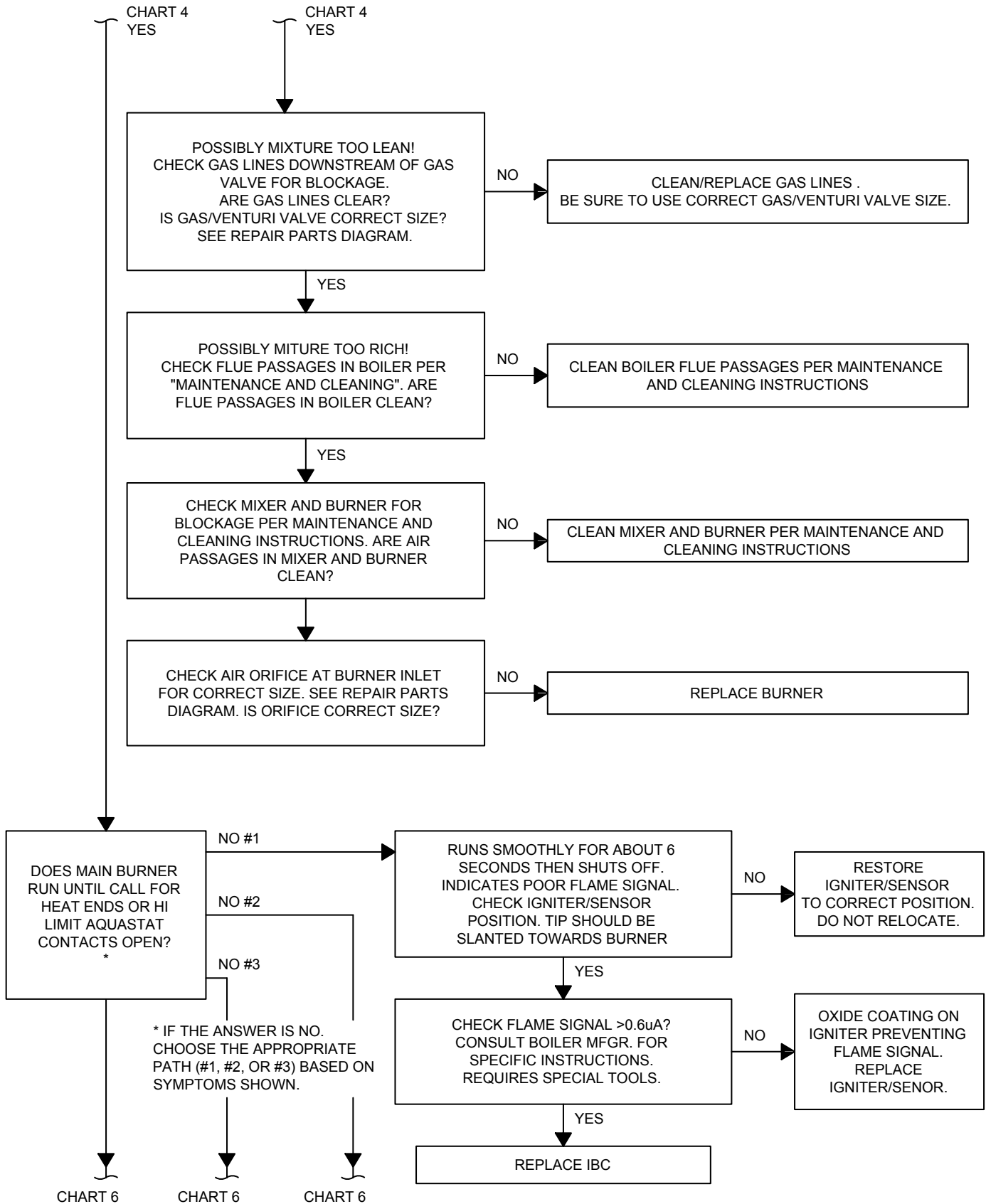

Troubleshooting Chart 6

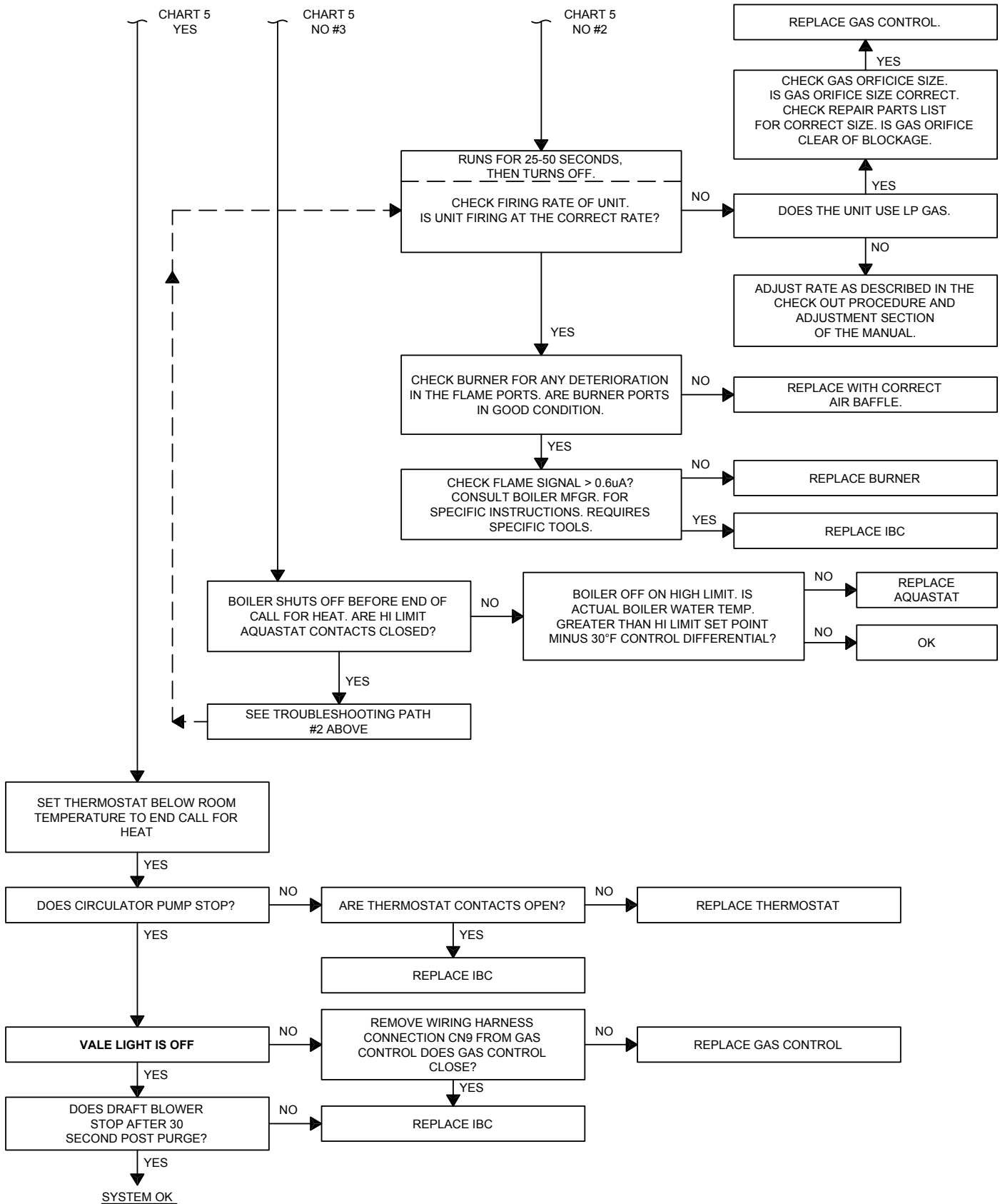

Differential Air Pressure Switch Check

Differential air pressure switch is safety device which prevents boiler from firing if there is air intake, boiler heat exchanger or vent blockage.

Following steps and diagram indicate location of connection points required to measure offset pressure using inclined Manometer or Differential pressure gauge. Only one device is required to measure offset pressure.

1. Turn off service switch, or lower thermostat setting.
2. Remove vinyl caps from Tee.
3. Install testing lines as shown to inclined manometer or differential pressure gauge with ability to read 0.01" to at least 6.0" w.c.
4. Turn on service switch and set thermostat to call for heat.
5. If manometer readings do not correspond to Table 11 check for possible causes:
 - Blockage or moisture in suction lines to switch.
 - Blockage or moisture in orifice installed in suction lines to switch.
 - Blockage in air intake or vent pipes.
 - Undersized air intake or vent pipes.
 - Loose blower wheel on motor shaft.
 - Incorrect pressure switch or pressure switch set-point.
 - Gas valve out of adjustment.
6. When pressure reading corresponds to Table 11 and pressure switch is operating properly, remove testing lines and reinstall vinyl caps to tee and 3-way connector.

Figure 22- Locations Of Connection Points Required To Check Differential Air Pressure

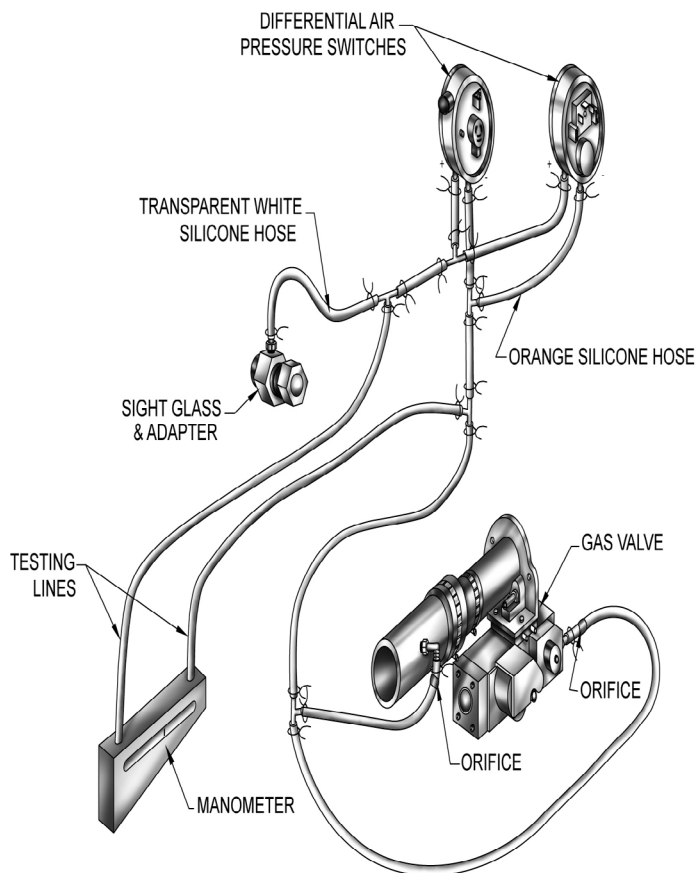

Table 11 - Correct Manometer Readings

Boiler Status	Differential Pressure	Switch	Contacts
Not Running	0"	3.5"	Closed
		0.5"	Open
Running Without Blockage (Approximate minimum vent lengths)	1.00" for Model 125	3.5"	Closed
	1.50" for Model 150		Closed
	1.50" for Model 175	0.5"	Closed
	2.00" for Model 200		Closed
Running With Blockage	Greater Than or Equal To Setpoints	3.5"	Open
		0.5"	Closed

16 - MAINTENANCE AND CLEANING

Acidic nature of flue gasses condensing on aluminum boiler sections cause formation of aluminum oxide. This oxide formation is normal, is generally uniform throughout boiler sections, and represents negligible mass of aluminum that is consumed by oxidation during life of boiler.

If left unchecked, this buildup may eventually cause blockage of flue gas passages in boiler sections, reducing efficiency, and ultimately shutting down boiler due to lack of combustion air flow.

Regular service and maintenance by qualified service agency must be performed to assure safe trouble free operation and maximum efficiency. It is recommended to service boiler at least once every 12 months.

Beginning Of Each Heating Season

1. Schedule annual service call by qualified service agency, which includes:
 - A. Examine flue passages between boiler sections, burner, and condensate lines, and clean if necessary following annual examination and cleaning instructions in paragraph F (below).
 - B. Visually inspect venting and air intake system for proper operation. If vent or air intake show any signs of deterioration or leakage, repair or replace immediately. Ensure proper re-assembly and re-sealing of vent and air intake system.
 - C. Check for and remove any obstruction to flow of combustion air or venting of flue gases.
 - D. Follow instructions for "Startup" on page 28.
 - E. Follow "Checkout Procedure & Adjustments" on page 35.
 - F. Visually inspect condensate drain line for proper operation. Check for deteriorated or plugged condensate drain line.
 - G. Check all gasket joints for leakage, and tighten bolts or replace gaskets if necessary.
 - H. Remove jacket front and top panels and check for piping leaks around relief valve and other fittings. Repair, if found. DO NOT use stop leak compounds.
2. Check boiler area is free from combustible materials, gasoline, and other flammable vapors and liquids.
3. Circulator pump and blower motor furnished with boiler are permanently lubricated from factory and require no further lubrication. Lubricate additional or non-factory supplied pumps and/or motors according to manufacturer's instruction.

Daily During Heating Season

1. Check for and remove any obstruction to flow of combustion air or venting of flue gases.
2. Check boiler area is free from combustible materials, gasoline, and other flammable vapors and liquids.

Monthly During Heating Season

1. Remove jacket front and top panels. Check for piping leaks around relief valve and other fittings. If found, contact qualified service agency to repair. DO NOT use stop leak compounds.
2. Test relief valve. Refer to valve manufacturer's instructions packaged with relief valve.
3. Visually inspect venting and air intake system for proper function. If vent or air intake show any signs of deterioration or leakage, contact qualified service agency to repair or replace immediately and ensure proper reassembly and resealing of vent and air intake system.
4. Visually inspect PVC condensate drain pipe for proper operation. If drain pipe shows any signs of blockage, leakage, or deterioration contact qualified service agency to clean, repair, or replace immediately.
5. Check air vent(s) for leakage.

Periodically During Heating Season

Where low water cutoffs are used, periodic inspection of low water cutoff is necessary, including flushing of float type devices. Refer to low water cut off manufacturer's specific instructions.

⚠ DANGER

Before servicing, turn off electrical power to boiler at service switch. Close manual gas valve to turn gas supply OFF to boiler. Failure to comply will result in death or serious injury.

⚠ WARNING

Following service procedures must be performed by qualified service agent. Boiler owner shall not attempt these steps. Failure to do so could result in death or serious injury.

NOTICE

Perform regular service and maintenance by qualified service agency at least once every 12 months to assure safe, trouble free operation and maximum efficiency.

NOTICE

Verify proper operation after servicing.

Annual Shut Down Procedure (End Of Each Heating Season)

1. Follow the instructions in "WHAT TO DO IF YOU SMELL GAS" on page 29.
2. If heating system is to remain out of service during freezing weather, and does not contain antifreeze, drain system completely. If boiler will be exposed to freezing temperatures, drain condensate lines. Otherwise, do not drain system or boiler.

Annual Examination And Cleaning Of Boiler Components

1. Examine flue passages. Remove blower assembly from casting. Follow procedure for examining and cleaning burner is described below.

Any buildup of sediment or aluminum oxide (white powdery or flaky substance) in flue passages must be cleaned as follows:

- A. Remove jacket front and top panels.
- B. Confirm manual gas valve is closed and disconnect gas line to gas valve at union.
- C. Disconnect wires to gas valve and igniter.
- D. Remove air inlet assembly from gas valve.
- E. Loosen, do not remove five nuts attaching blower adapter assembly to boiler.
- F. Remove two igniter screws. Carefully remove igniter. Do not touch igniter element with your fingers or hands as oils or debris will cause premature failure.
- G. Remove five nuts and blower adapter assembly. Remove burner and gaskets.

- H. Aluminum oxide deposits are water soluble and may be rinsed away with spraying or running water.
 - I. Use flexible handle nylon brush to loosen sediment and aluminum oxide on all exposed heating surfaces of boiler. Take care brush does not get stuck in heat exchanger.
 - J. After brushing and rinsing, remove any remaining loosened sediment using vacuum with snorkel attachment.
 - K. Inspect burner for foreign matter in flame ports or inside burner. Remove any foreign matter by blowing with compressed air or vacuuming.
 - L. Install burner and gaskets. Position blower adapter assembly over studs. Install five nuts, do not tighten. Install igniter and igniter gasket and fasten with two screws. Do not touch igniter element with your fingers or hands as oils or debris will cause premature failure. Tighten five nuts holding blower adapter assembly.
 - M. Connect gas line to gas valve; air inlet assembly to gas valve (using 2" x 1½" flexible coupling); pressure switch hose to gas valve and air inlet assembly; 2" flexible coupling to boiler exhaust port; igniter wires; and gas valve wires.
2. Visually inspect condensate trap. Clean out any visible foreign material or debris from condensate lines as described below.
 - A. Inspect for sediment or blockage.
 - B. Flush out with water or vacuum.
 - C. Follow instructions in "Near Boiler Piping" on page 8, for filling condensate trap with water.
 3. Inspect flue connector using following steps.
 - A. Loosen clamp on draft inducer end of 2" flexible coupling connecting vent tee to exhaust port.
 - B. Inspect interior of vent tee. Clean any buildup of sediment on inside surface.
 - C. Connect 2" flexible coupling to draft inducer outlet.

SERVICE RECORD

Date	Service Performed	Company Name & Tech Initials	Company Address & Phone #

IMPORTANT

In accordance with Section 325 (f) (3) of the Energy Policy and Conservation Act, this boiler is equipped with a feature that saves energy by reducing the boiler water temperature as the heating load decreases.

This feature is equipped with an override which is provided primarily to permit the use of an external energy management system that serves the same function.

THIS OVERRIDE MUST NOT BE USED UNLESS AT LEAST ONE OF THE FOLLOWING CONDITIONS IS TRUE:

- An external energy management system is installed that reduces the boiler water temperature as the heating load decreases.
- This boiler is not used for any space heating
- This boiler is part of a modular or multiple boiler system having a total input of 300,000 BTU/hr or greater.
- This boiler is equipped with a tankless coil.