



comfortWAVE

Ductless Series Fan Coil, Air Handlers

CAW

FAN COIL, CASSETTE, AIR HANDLER Installation, Operation and Maintenance Manual

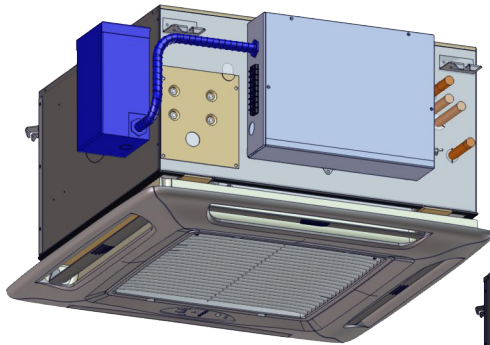

MODELS CAW 08-12

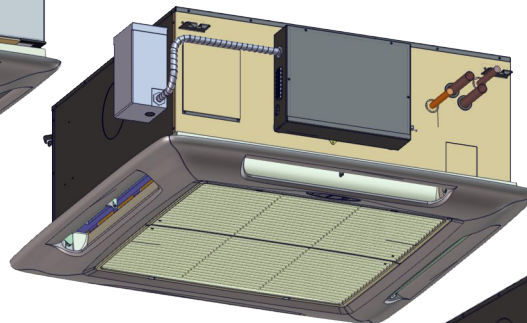

MODELS CAW 18-20

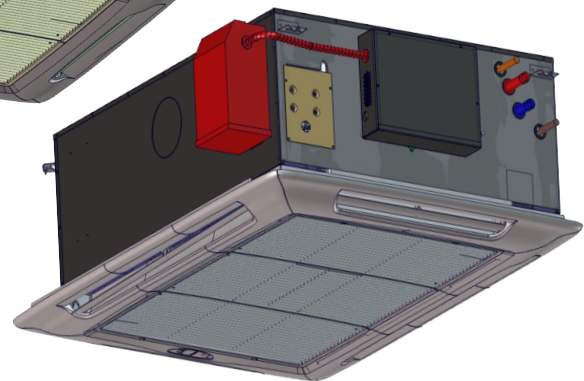

MODELS CAW 33-36



ECR international
EST. 1928
A Family of Heating & Cooling Brands.

ECR International, Inc.

2201 Dwyer Avenue,

Utica NY 13501

web site: www.ecrinternational.com

TABLE OF CONTENTS

Receiving Information	3
Important Safety Information.....	4
General Product Information	5
Dimensional/Physical Data	6
Unit Mounting	9
Features.....	11
Condensate Piping	12
Duct Connections	13
Final Assembly	14
Electrical Wiring	16
Thermostat Operation	19
CAW Wall Mounted Thermostat Operation	20
Sequence Of Operation — CAW Infrared Control System.....	21
CAW Infrared Control System - Overview.....	23
CAW Infrared Control System - Settings	27
CAW Infrared Control System - Operation	30
Maintenance	35
Troubleshooting.....	36
Specifications & System Performance	38

Unit has been tested and
rated in accordance with:
ANSI/AHRI Standards
440-2008
UL-1995



Check our website frequently for updates: www.enviromaster.com

Information and specifications outlined in this manual in effect at the time of printing of this manual. ECR International Inc. reserves the right to discontinue, change specifications or system design at any time without notice and without incurring any obligation, whatsoever.

RECEIVING INFORMATION

General Information

- Installation shall be completed by qualified agency.
- Installer - This manual is property of owner. Leave with owner when installation is complete.
- Owner - Retain this manual and warranty for future reference.

When calling for assistance, please have following information ready:

Model Number _____

Serial Number _____

Date of installation _____

Receiving Inspection

- Inspect unit for damage. Report any shipping damage to carrier immediately.
- Check rating plate on unit. Verify power supply meets available electric power for installation.
- Verify unit received meets description of product ordered, including applicable specifications.

IMPORTANT SAFETY INFORMATION

All field wiring shall conform to requirements of authority having jurisdiction or in absence of such requirements:

- United States - National Electrical Code, ANSI/NFPA 70. Unit must be electrically grounded in conformance to this code.
- Canada - CSA C22.1 Canadian Electrical Code Part 1.

WARNING

Electrical shock hazard. Improper assembly and/or installation could result in death or serious injury. Have a qualified service agency install and service this appliance. Read this manual and understand all requirements before beginning installation.



**Become Familiar With Symbols
Identifying Potential Hazards.**

DANGER

Indicates a hazardous situation which, if not avoided, WILL result in death or serious injury.

WARNING

Indicates a hazardous situation which, if not avoided, could result in death or serious injury.

CAUTION

Indicates a hazardous situation which, if not avoided, could result in minor or moderate injury.

NOTICE

Indicates information which should be followed to ensure proper installation and operation.

WARNING

Tampering with this unit is dangerous and could result in death or serious injury. Do not modify or change this unit.

Safety Information

- Have a qualified service agency install and service this appliance.
- Turn off electrical supply before servicing unit.
- Do not have other devices such as fire alarm circuits, BMS circuits, etc on same circuit as the unit.
- Inspect all parts for damage prior to installation and start-up.
- Do not use unit if it has damaged wiring, is not working properly, or has been damaged or dropped.
- Connect to properly grounded electrical supply with proper voltage as stated on rating plate.
- Use proper over-current protection (i.e. time-delay fuse/HACR Breaker) as listed on Rating Plate.
-
- Service or repair of unit using manufacturer approved replacement parts only.
- Do not use any mechanical or electrical controllers which have been wet. Replace any defective controller.
- Do not support any part of ceiling with appliance, associated wiring or pipe work.
- Check rating plate on unit before installation. Verify voltage shown is same as electric supply to unit. Rating plate is located on top panel.

Product Description

- Available in three cabinet sizes with six output capacities from 8,000–36,000 Btuh.
- Available in 115Vac and 208/230Vac.
- 2 pipe or 4 pipe configurations.
- Factory installed electric heat option (2 pipe only). No field installed electric heat kits are available.
- Designed for low noise levels, easy installation, easy maintenance and slim line fascia, insure minimum intrusion into conditioned environment.
- Galvanized steel cabinet with fire-resistant thermal and acoustic foam insulation.
- Expanded polystyrene drain pan, fire retardant thermoplastic liner.
- 24Vac wall thermostat connections, thermostat not included.
- Optional hand held remote infrared controller available.
- Controls also feature anti-short-cycle timer, post purge fan relay, and an on-board 30 amp electric heat relay.
- 24Vac Transformer. See thermostat requirements in this manual.
- Light grey high-impact ABS fascia.
- All units can be operated using wall thermostat.

Remote Thermostat Application (Wall mounted)

- Units require remote thermostat for operation. On-board controller is not included.
- Controller offers limited options when operated by remote thermostat.

(Optional) Infrared Hand Held Remote Thermostat Applications

- Infrared hand held remote uses a custom control board featuring programmability, configuration and multiple modes of operation.
- Units include on-board microprocessor controller with infrared hand held remote.
- Infrared hand held remote is required to adjust settings and configure controller.
- Bank of DIP switches for setting operation is included.
- Custom control board featuring programmability, configuration, and multiple modes of operation.
- Configurable for wall thermostat operation.

Air Systems

- User accessible permanent, washable, filter which may be vacuum cleaned.
- Branch duct knockouts on three sides for remote discharge locations; use two non-adjacent sides.
- Fresh air intake capability with two knockout locations
- Four plastic air vanes, motor driven with auto sweep or fixed position stop setting on models 18-36. Models 08–12 are equipped with manually-adjusted air vanes.
- Fans are backward curved impeller centrifugal design: dynamically and statically balanced; and mounted on integral mounting rails.

- Single fan models 08, 12, 18 and 20 are designed with fire-retardant plastic or aluminum impellers.
- Twin fan models 33 and 36 are designed with fire retardant plastic impellers.
- Multispeed motors are enclosed type with thermal protection and sealed bearings.

Coil

- Coil is seamless, copper tubing, arranged in staggered configuration, with enhanced aluminum fins, tested to 250 psig.
- Tubes are mechanically expanded for secure bonding to fin shoulder.

System Options

- 24Vac wall thermostat.
- Electric Heat (@ 230Vac) - Chilled water only (2 pipe).
 - 1.5 kW — models 8–12
 - 3 kW — models 18-20
 - 5 kW — models 33-36

Mechanical Characteristic

Metal framed filters are fitted, reusable.

Condensate Pump

- Carries water out of unit. Pump is fixed to mounting bracket, can be withdrawn from side of chassis. Inspection hole allows visual check of pump during operation.
- Float switch stops cooling action, shuts off chilled water valve if pump becomes blocked or fails.
- Pump total lift is 36" (0.9 m) or less measured from base or bottom of unit.

Air Vanes

- Manually adjustable air outlet vanes models 08-12 or electric motor driven on models 18-36.
- Motorized air vanes can be set to auto sweep or stopped in fixed position.

Fresh Air Connection

- May introduce fresh air to unit by addition of ducts connected to fresh air knockouts on cassette case.
- Manufacturer recommended maximum length is 10' (3m) of 4" (0.1m) diameter duct. Fresh air volume is approximately 7–10% of unit's published maximum air flow if more than 10% make up air is needed fresh air booster fan is required.

Heating

- Cassette may be fitted with optional electric heaters equipped with over temperature limit switches or as 4 pipe unit with separate hot water coil.

DIMENSIONAL/PHYSICAL DATA

Figure 1 - Dimensions: Models 8, 12

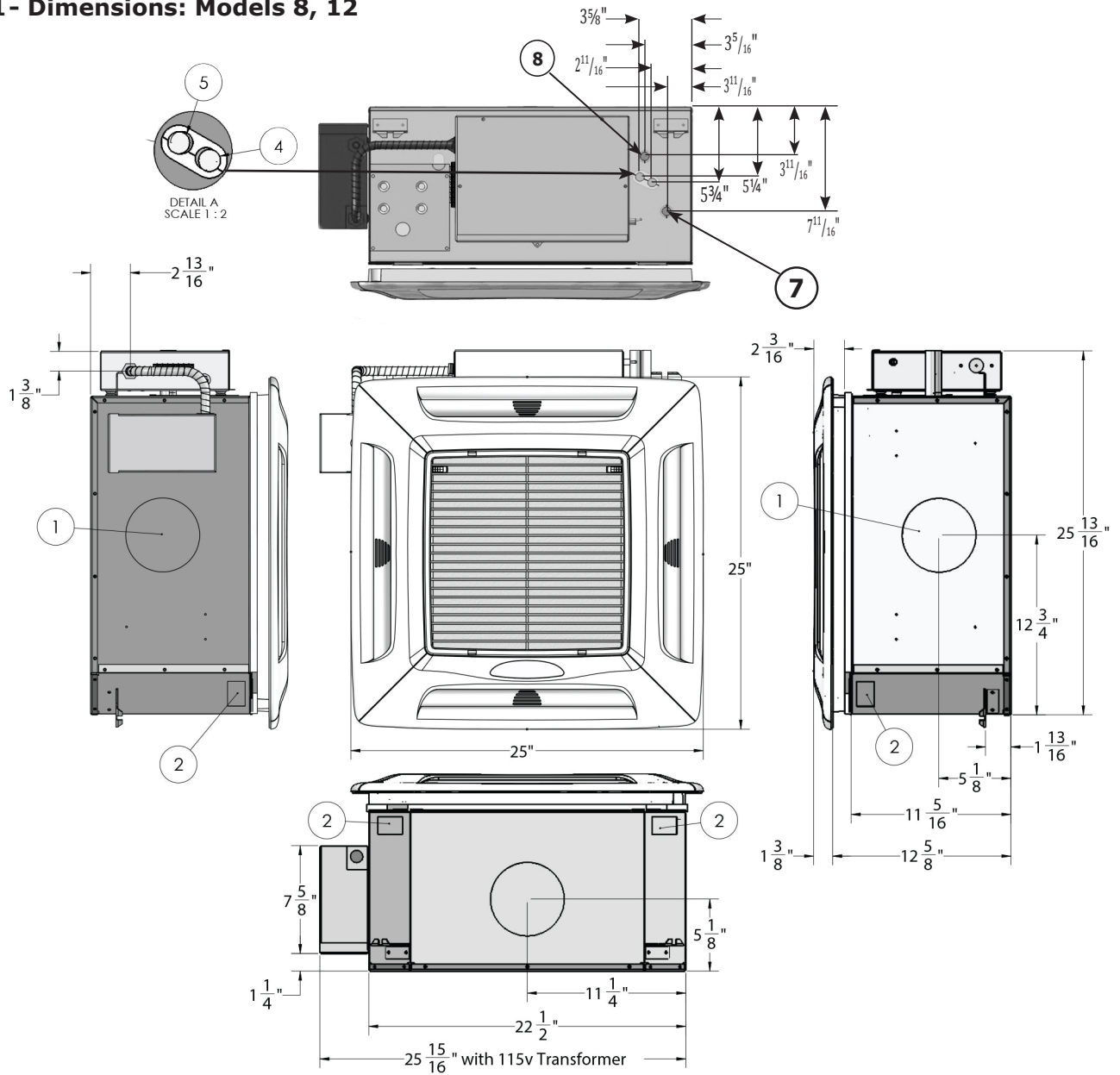

FEATURES	
1	Optional Discharge Knockouts 5 1/4" Diameter (3 Available)
2	Fresh Air Inlet Knockouts 1 1/4 x 2 1/2 Inches (2 Available)
3	Condensate Discharge 1/2 Inch Diameter
4	Chilled Water "IN" 5/8"
5	Chilled Water "OUT" 5/8"
6	Condensate Pump Access Panel
7	Hot Water "IN"
8	Hot Water "OUT"

DIMENSIONAL/PHYSICAL DATA

Figure 2- Dimensions: Models 18, 20

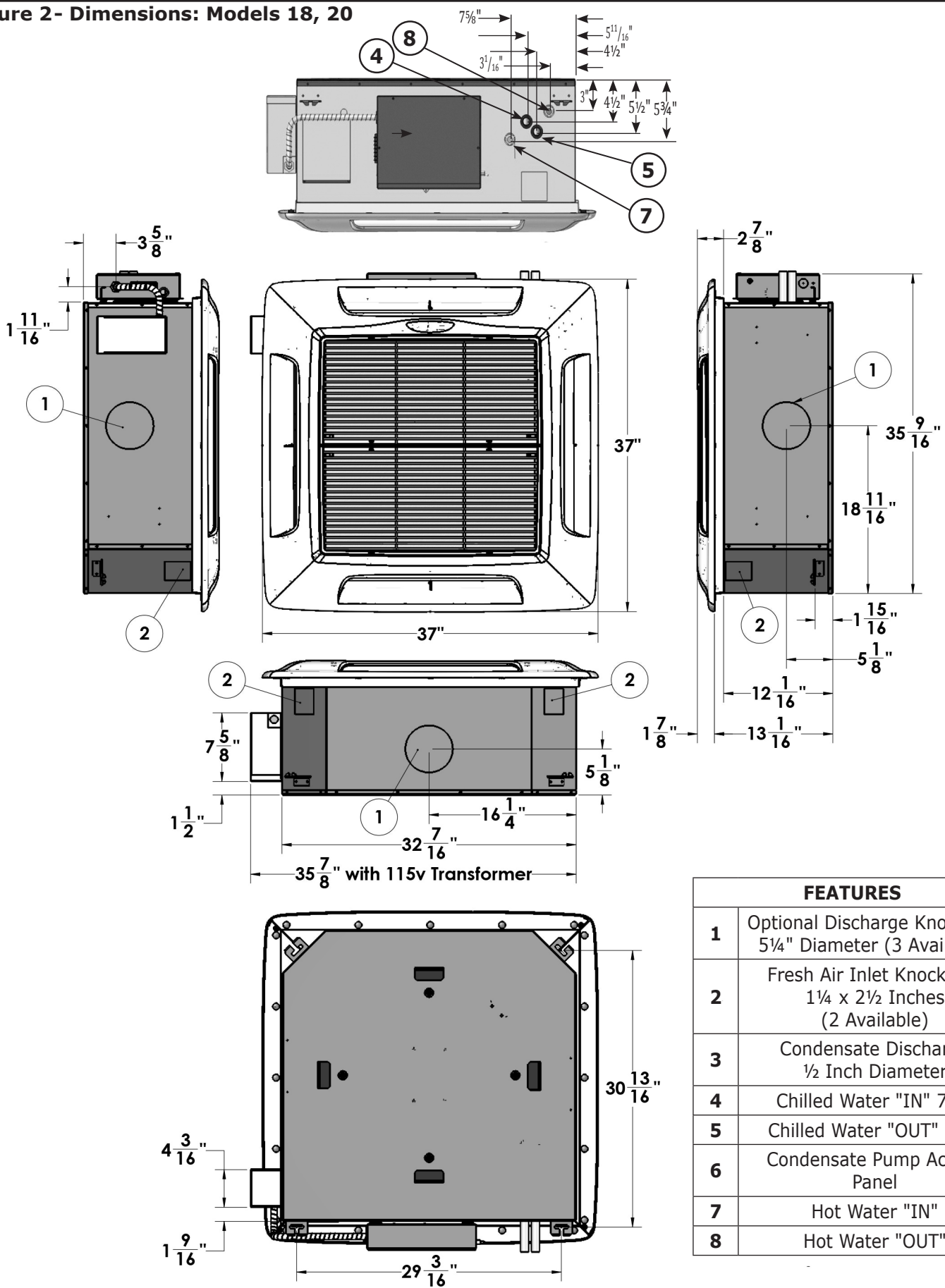

FEATURES	
1	Optional Discharge Knockouts 5 1/4" Diameter (3 Available)
2	Fresh Air Inlet Knockouts 1 1/4 x 2 1/2 Inches (2 Available)
3	Condensate Discharge 1/2 Inch Diameter
4	Chilled Water "IN" 7/8"
5	Chilled Water "OUT" 7/8"
6	Condensate Pump Access Panel
7	Hot Water "IN"
8	Hot Water "OUT"

DIMENSIONAL/PHYSICAL DATA

Figure 3- Dimensions: Models 33, 36

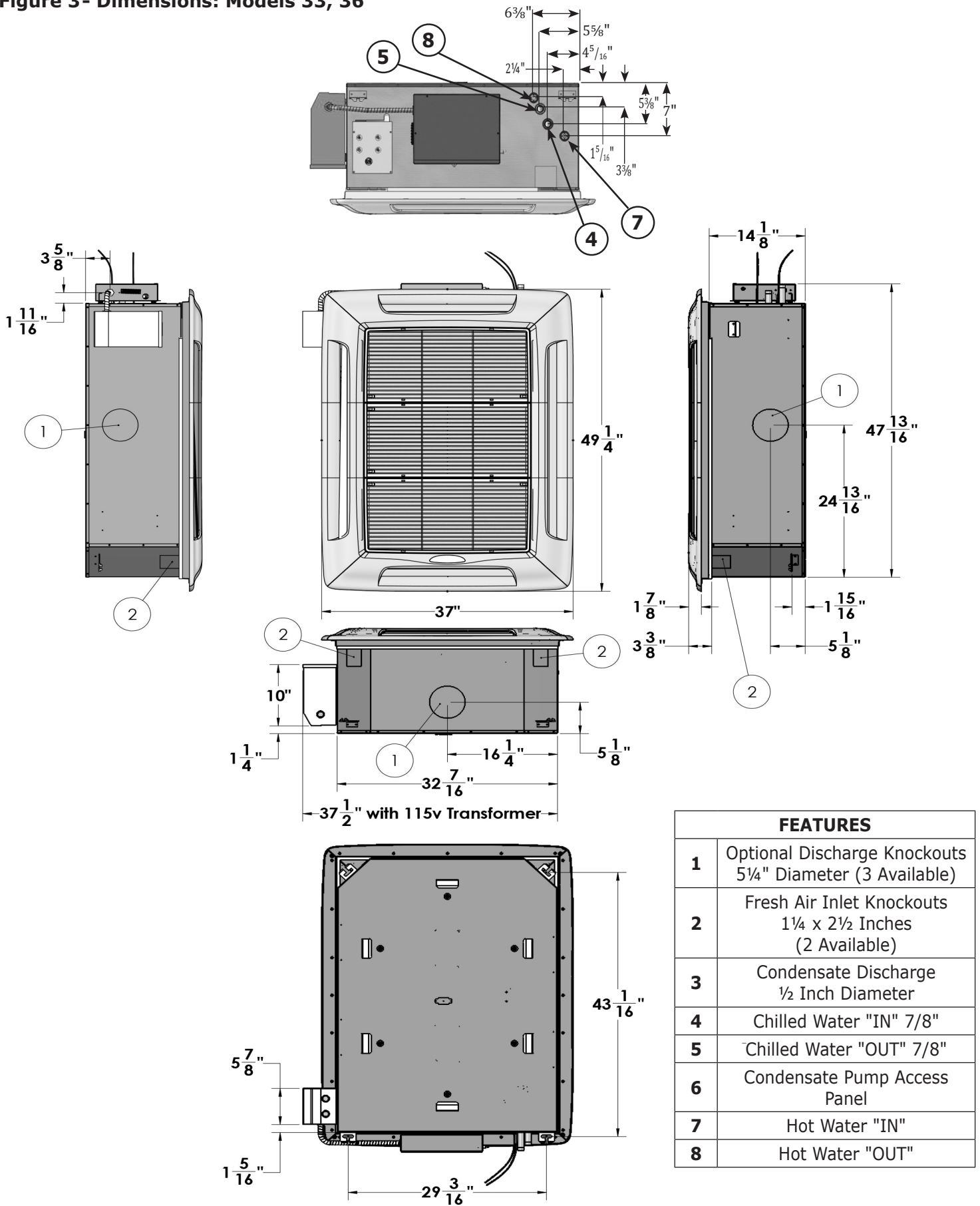

FEATURES	
1	Optional Discharge Knockouts 5 1/4" Diameter (3 Available)
2	Fresh Air Inlet Knockouts 1 1/4 x 2 1/2 Inches (2 Available)
3	Condensate Discharge 1/2 Inch Diameter
4	Chilled Water "IN" 7/8"
5	Chilled Water "OUT" 7/8"
6	Condensate Pump Access Panel
7	Hot Water "IN"
8	Hot Water "OUT"

Unpacking

NOTICE

Do not throw template away with packaging. See Figure 8 Page 10.
Do not use drain or water connections for lifting.

Cassette fascia and main chassis are packaged together.

1. Remove banding straps and lift cardboard lid.
2. Fascia is packed in bubble wrap on top of chassis. Fascia is not attached to chassis for shipping.
3. Cardboard template is between chassis and fascia. See Figure 8 Page 10.
4. Lift fascia and template from box and set aside.
5. Remove cassette chassis from box utilizing four corner brackets for lifting.
6. To protect fascia from dirt and damage return them to box until ready to install.
7. Do not throw away two polystyrene blanking-off pieces with packaging. See Figure 6.

Blanking Off

Fascia discharge slot(s) need blanking off when ducts are used to channel conditioned air to other areas.

- Position two polystyrene blanking off strips (provided) in fascia discharge slots to direct air to ducts.
- Up to two non-adjacent sides may be blanked off.

If fascia discharge slot needs blanking off — Figure 6

1. Remove inlet grilles and filters. See Figure 4 and Figure 5.
2. Turn fascia over to expose polystyrene insulation.
3. Push one polystyrene blanking-off pieces into recess in polystyrene fascia insulation.

Figure 4 - Models 08–12 , One Grille & One Filter

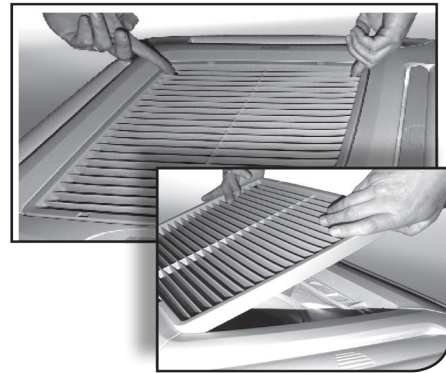

Figure 5 - Model 18 - 20, Two Hinged Grilles And Two Filters

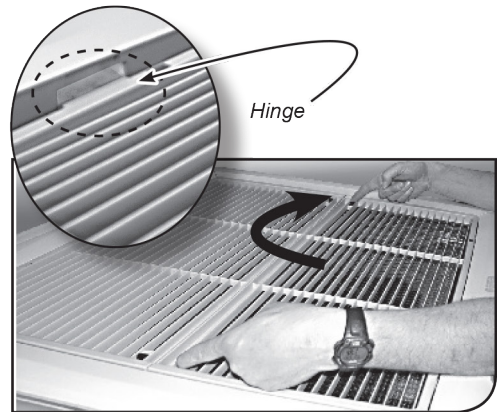

Figure 6 - Applying Blanking-Off Pieces



UNIT MOUNTING

Ceiling Opening

⚠ CAUTION

Mount unit with lowest moving parts at least 8 feet above floor or grade, to avoid contact with moving parts. Failure to follow these instructions could result in minor or moderate injury.

NOTICE

Verify ceiling grid is supported separately from cassette. Do not support ceiling by any part of cassette unit, fascia or any associated wiring or pipe work.

Table 1 - Ceiling Opening Sizes

Model	Dimensions
08 & 12	23 1/4" x 23 1/4" (591 x 591 mm)
18 & 20	33 7/8" x 33 7/8" (860 x 860 mm)
33 & 36	33 7/8" x 46" (860 mm x 1168 mm)

Figure 7- Spacing Requirements

Dimension A + 1" = Minimum Space Above False Ceiling For Installation

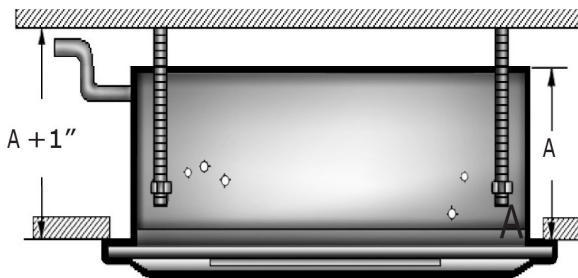

Model	Dimensions A
08 & 12	12 5/8" (0.32 m) min.
18 & 20	13 1/16" (0.33 m) min.
33 & 36	33 7/8" x 46" (860 mm x 1168 mm)

Figure 8- Ceiling Cutout/Rod Placement Template (Shipped With Unit)

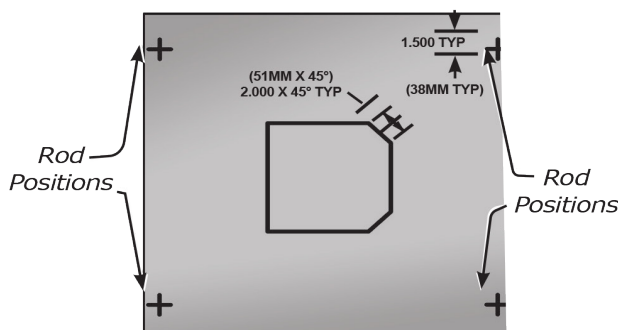

Positioning

Select cassette installation position.

1. Pipe work, electrical connections, control box and condensate pump access panels should be readily accessible. Refer to cassette dimensions. See Figures 1, 2 & 3.
2. Position unit at least 5 ft. (1.5m) from wall or similar obstruction, and at least 8 ft (2.4m) from the floor or grade.
3. Position unit as close to center of room as possible to insure even air distribution.
4. Position unit so discharge air does not blow directly on remote wall wired thermostat, if used.
5. Do not position unit directly above any obstructions.
6. Verify Condensate drain has sufficient fall — 1" per 10' (8 mm/m) in any horizontal run between cassette and drain.
7. Maximum condensate pump lift is 36" (0.9m) from bottom of unit.
8. Maintain minimum 1" (25.4mm) clearance above cassette depth and false ceiling for proper installation. See Figure 7.
9. Cut opening in false ceiling using size shown in Table 1.

Wired Wall Thermostat (not supplied)

Locate wired wall mounted thermostat to ensure good temperature control. Select installation position.

1. Position thermostat approximately 5 ft. (1.5m) above floor level.
2. Avoid external walls and drafts from windows and doors.
3. Avoid positioning near shelves and curtains as these restrict air movement.
4. Avoid heat sources (direct sunlight, heaters, dimmer switches, etc.)
5. Seal wiring holes in wall behind thermostat to avoid drafts.

Mounting Method

- In existing construction, remove enough ceiling panels to provide clearance space for mounting unit to ceiling joists.
- Before beginning installation, inspect unit location, test strength of ceiling joists to ensure they will support unit weight.
- Determine mounting method:
 - A. Wooden beams use threaded rods, washers, and nuts to suspend support brackets.
 - B. Metal structures, secure threaded rods on existing angle or install new support angle.
 - C. Newly built concrete slabs secure threaded rods with inserts and embedded bolts.
 - D. For previously built concrete slabs install hanging bolts with expansion anchor
- Follow local building codes for required safety cables, braces, etc.

Mounting

1. Use template to cut ceiling opening and determine rod positions. See Figure 8, Page 10.
2. Install hanger bolts using 3/8" (10mm) all-thread rod at centers. See Table 2.
3. Prepare installation guides by folding metal bracket by hand along perforations. See Figure 9.
4. Lift cassette onto hanging rods.
5. Level at correct distance from ceiling with aid of installation guides. See Figure 10.
6. Secure unit in position with locknuts and washers on either side of cassette bracket.
7. Insure threaded rod does not protrude more than 2" (51mm) below mounting bracket. See Figure 11.
8. If ceiling is not level or even, install cassette level to ensure correct pump operation and to maintain fan clearances.
9. Place carpenter's level on unit.
10. Maximum slope of 1/8" (3mm) over length of chassis toward condensate drain is allowed. Slight discrepancy between cassette and ceiling will be taken up by fascia foam seal.

Figure 9- Mounting Brackets

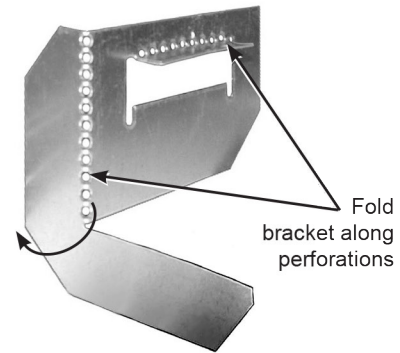
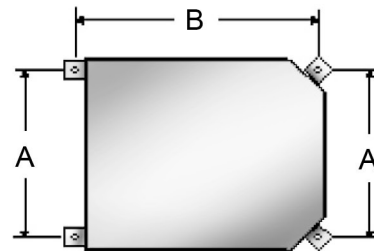

Table 2 - Ceiling Rod Positions



Model	Dimensions A	Dimensions B
08 & 12	19.50" (495mm)	22.87" (581mm)
18 & 20	29.19" (740mm)	30.80" (782mm)
33 & 36	29.19" (740mm)	43.06" (1094mm)

Figure 10- Positioning Installation Guides

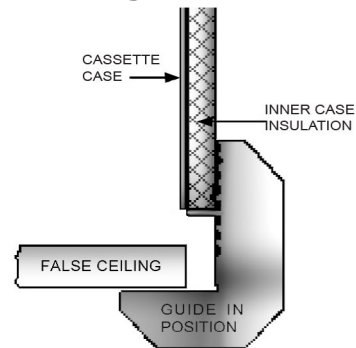
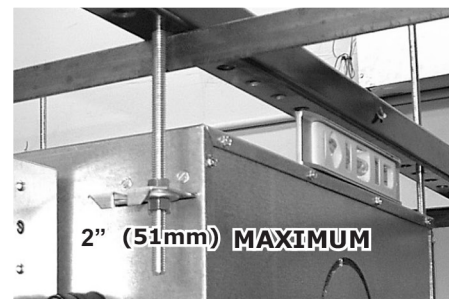

Figure 11- Threaded Rods Must Not Protrude More Than 2 Inches Below Mounting Brackets



NOTICE

Insulate chilled water and condensate pipes up to chassis to prevent condensation which may damage ceiling and objects located below.

Insulate chilled water valves to prevent sweating.

Cassette is supplied with 1/2" I.D. flexible PVC hose for connection to copper or plastic drain piping. See Figure 13.

Condensate Piping

1. Maximum pump lift is 36" (0.9m) from base or bottom of unit.
2. Highest point in condensate piping should be as close to unit as possible. Prevents large volume of water draining back into unit when it is switched off. See Figure 12.
3. Check valve at pump discharge to prevent water from draining back into unit. Piping technique minimizes issues if check valve is stuck open from airborne debris.
4. Slope condensate pipe-work downward from highest point in direction of water flow with minimum gradient of 1" per 10' (8mm/1m). No uphill gradients except in first 18" (0.45m) of pipe-work from cassette. See Figure 12.
5. When multiple cassettes are connected to common condensate drain, ensure drain is large enough to handle total volume of condensate.
6. Drain line vent may be required to prevent siphoning of water from drain pan and associated noise.

Figure 12 - Highest Point Of Condensate Piping Should Be As Close To Unit As Possible

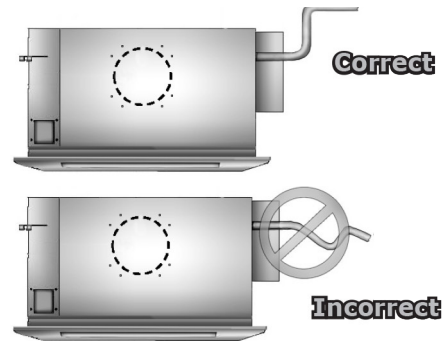
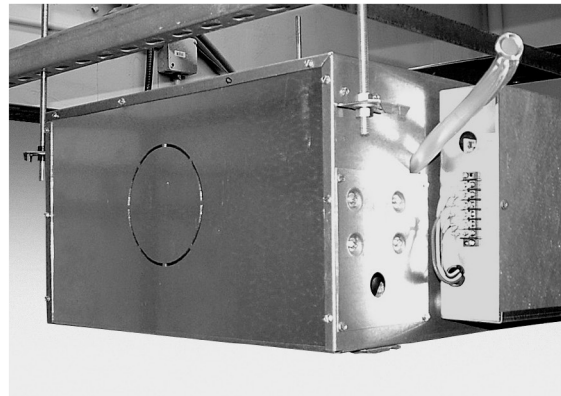

Figure 13 - Condensate Drain

Condensate Drain Connection



DUCT CONNECTIONS

Attach branch duct and fresh air duct collars to cassette chassis.

Install no more than 10 feet (3m) of branch duct or fresh air duct.

1. Locate knock-out holes. See Figure 14.
Number of knockouts vary with unit size.
 - Branch duct knock-outs are 5¼" (133mm) round.
 - Fresh air knockouts are:
 - a. 1¼" x 2½" (32 x 64mm) rectangular models 08 - 12.
 - b. 3" (76mm) square models 18-36
2. Cut black insulation around knock-out. See Figure 15.
3. Snip tabs holding knock-out in place.
4. Remove metal knock-out and black insulation.
5. Attach field supplied duct collars to chassis using self-drilling screws.
6. Repeat above steps for remaining duct work.

Figure 14- Knockouts

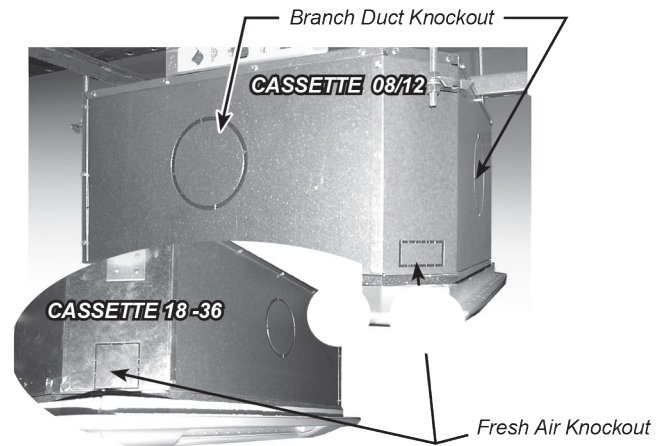

Figure 15 - Cut Insulation And Snip Out Knockouts



Assembly Instructions

1. Install four fascia mounting bolts. See Figure 16.
 - a. Locate supplied bolts and washers from kit bag.
 - b. Place washers on bolts.
 - c. Screw mounting bolt with washer into chassis leaving approximately 1" (25mm) to hang fascia.
2. Ensure white panel fasteners holding fascia polystyrene are pushed firmly in, fasteners may have loosened in transit. See Figure 17.
3. Lift fascia onto chassis mounting bolts. Align key hole brackets with mounting bolts. Slide fascia forward to lock into position.
4. Cassette 18 - 36 units, connect vane motor plug. Plug into socket connection on chassis. Figure 19 Page 15.
 - a. Ensure polarized connector (2 position) is in proper orientation and connected.
 - b. Route wires to prevent them from becoming trapped, cut, broken or chaffed. See Figure 18.
5. Cassette models CAW (Infrared handheld remote) contain second cable connection to control box for infrared unit mount control. See Figure 20 Page 15.
6. Ensure polarized (10 position) connector is in proper orientation and connected.
7. Route wires to prevent them from becoming trapped, cut, broken, or chaffed. See Figure 18.
8. Tighten fascia up to Cassette chassis. Verify seal is obtained between fascia and chassis, necessary to prevent recirculation. See Figure 21 Page 15.
9. With filter(s) in place, install inlet grille(s) onto fascia.

Figure 16 - Mounting Bolts

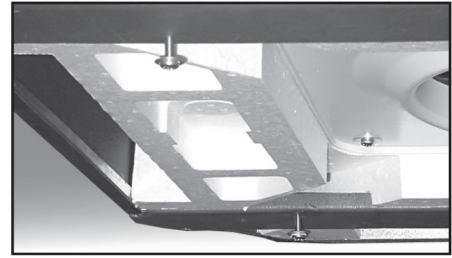

Figure 17 - Push In White Panel Fasteners

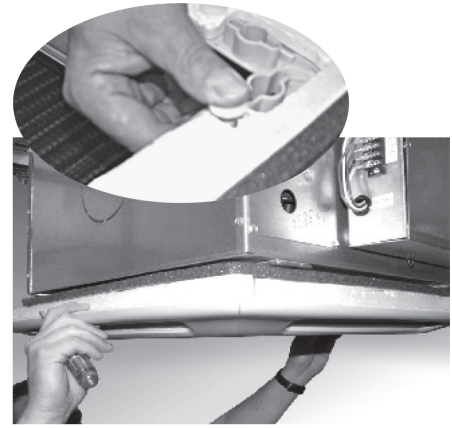

Figure 18 - Wire Routing



Figure 19 - Connect Vane Motor Plug Into Socket On Chassis

Female vane motor plug on chassis



Male Vane Motor Plug On Fascia

Figure 20 - Connect Infrared Control Cable

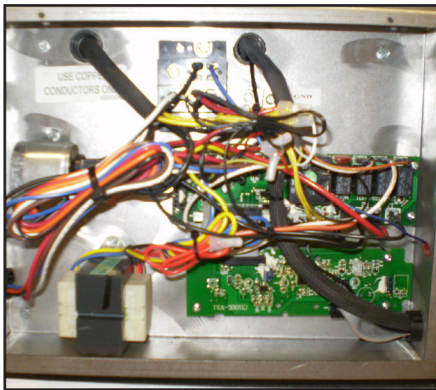
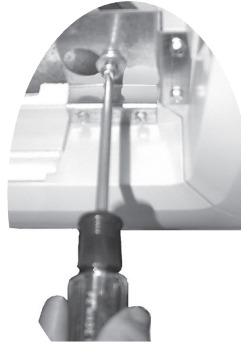

Figure 21 - Secure Fascia To Chassis



Do not over-tighten bolts could damage fascia and drain pan.

Figure 22 - Adjust Louver Position 30° From Plumb



General Electrical Requirements

Electrical wiring must be in accordance with all electrical codes. In absence of such requirements to the National Electrical Code (NEC).

Any manufacturer wiring requiring replacement must be replaced with wiring material having temperature rating of at least 105°C.

⚠ WARNING

Electrical shock hazard. Turn OFF electrical power supply before making electrical connections. Failure to do so could result in death or serious injury.

1. Standard unit voltage is 208/230Vac (60Hz, 1Ph). Verify model's electrical requirements from rating plate.
2. Wires shall be capable of carrying maximum load current under non-fault conditions at stipulated voltages.
3. Avoid large voltage drops on cable runs, particularly in low-voltage wiring.
4. Use correct cable size to insure voltage drop of less than 1 volt in control wiring.
5. Connect electrical supply after completing water pipe work.
6. Low-voltage wiring must be at least 18 AWG.

Connect Wiring

1. Loosen four screws on front of control box cover. Slide cover up and off to access high-voltage wiring. See Figure 23.
2. Rating plate is located on outside of control box cover.
3. Protect unit by time delay fuse or breaker. Check rating plate for circuit ampacity and breaker or fuse size. Use only HACR type breakers. Select proper wire for ampacity rating.
4. Connect local disconnect switch within 3 feet of unit.

High-Voltage Electrical Wiring

1. Inspect existing wiring for cut or frayed wires. Replace if found. See Figure 24.
2. Connect power wire to L1 at power location.
 - 115Vac - Route Cable through 115v Transformer box for high voltage electrical wiring
 - 208/230Vac – Route cable through hole in control box for high voltage electrical wiring.
3. Connect ground wire to ground lug or lead at same location in control box.

Terminate ALL unused wires with wire nut or crimp connector.

Figure 23 - Remove Control Box Cover



Figure 24 - Electrical Connections

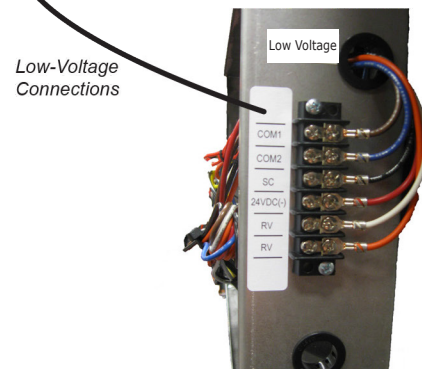
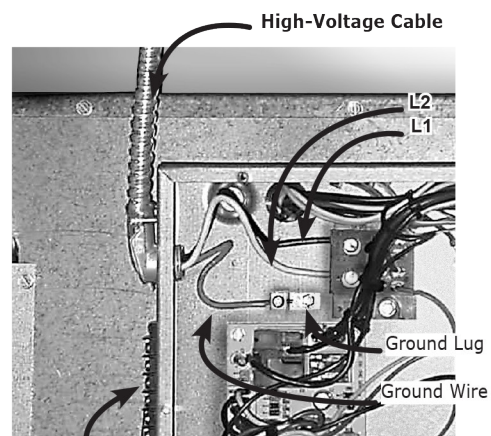

Low-Voltage Electrical Wiring

Low-voltage interconnect wiring must be 18 AWG.

1. Locate 24Vac control transformer in air handler. Provides low-voltage control power to both air handler and chilled water valve. Low-voltage interconnect control wiring may vary depending on model selected.
2. Refer to wiring diagram for low voltage connection to appropriate terminals.
3. Replace control box cover with wiring diagram facing in after making all connections. Secure with four screws.

Units rated 208/230Vac, primary side of transformer are factory wired for 230Vac.

Change transformer tap from orange to red for 208V power supply. Refer to wiring diagram located on inside control box cover. See Figure 27.

Figure 27 - Wiring Diagram Location

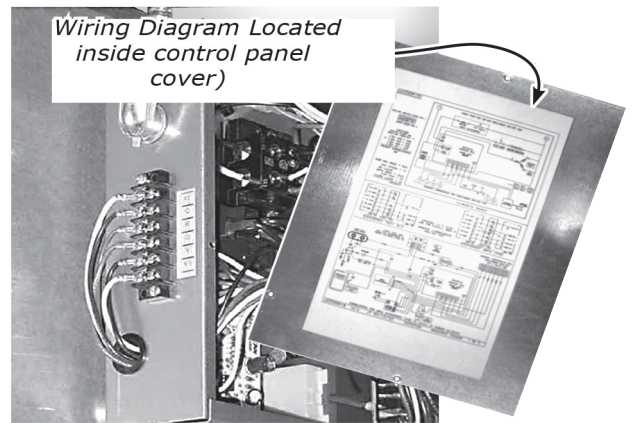

Figure 28 - Optional Transformer Wiring

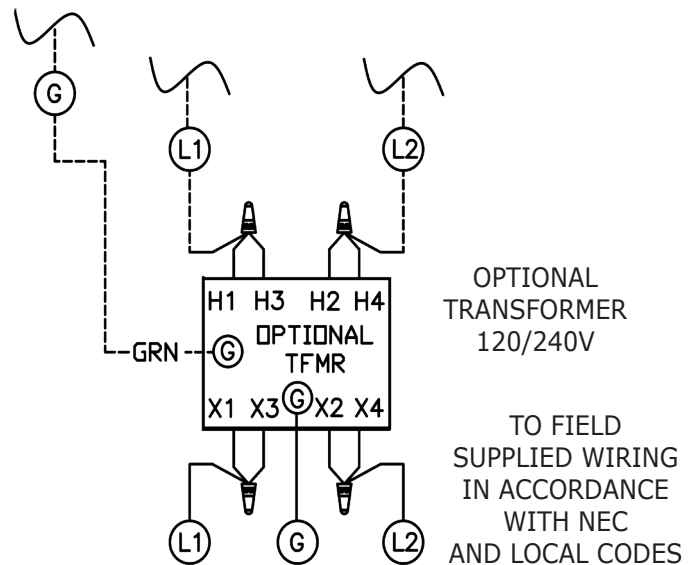

Figure 25 - Low-Voltage Interconnections - Wall Mounted Remote Thermostat

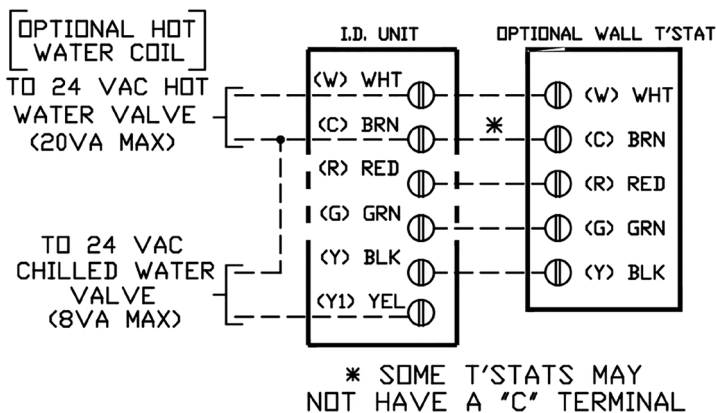

Figure 26 - Low-Voltage Interconnections - IR Handheld Remote Controls with Optonal Wall Thermostat

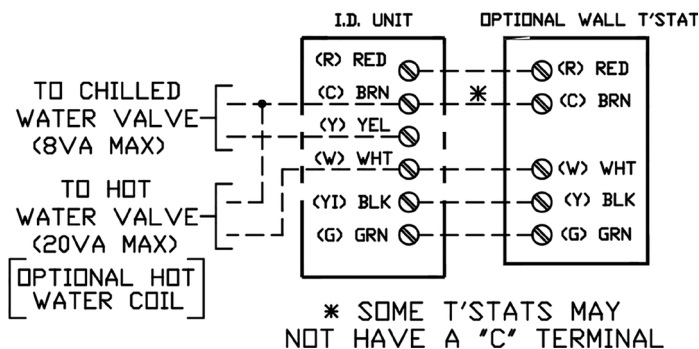

Figure 29 - 08-20 Transformer

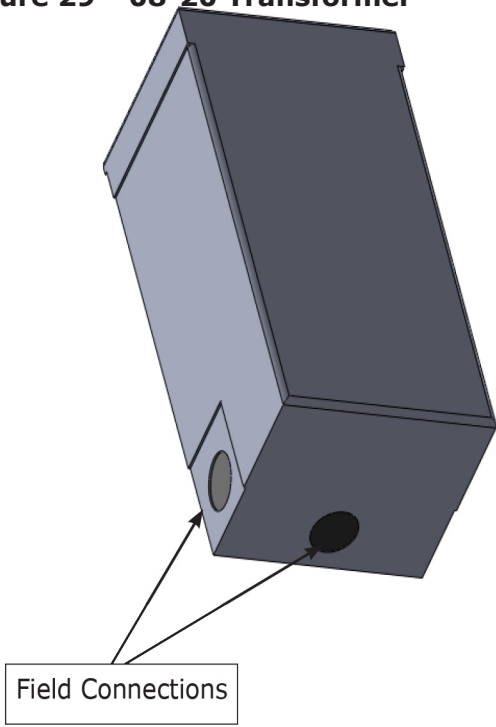

Figure 31 - 33-36 Transformer

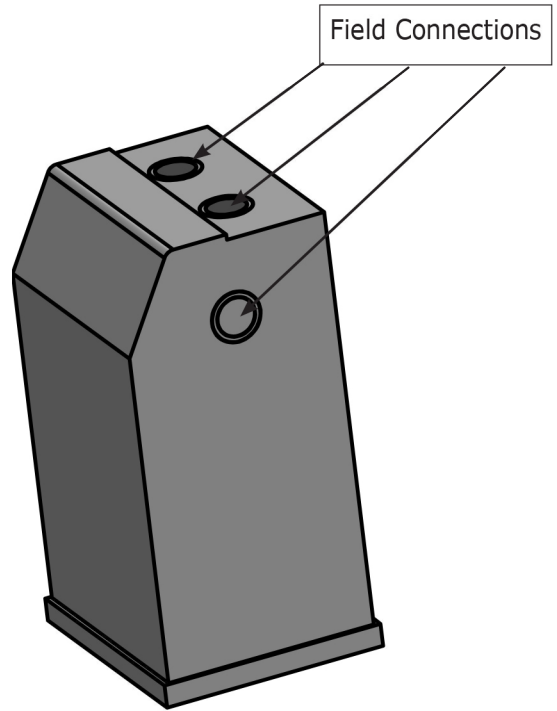

Figure 30 - CAW 08-20 Transformer Mounting

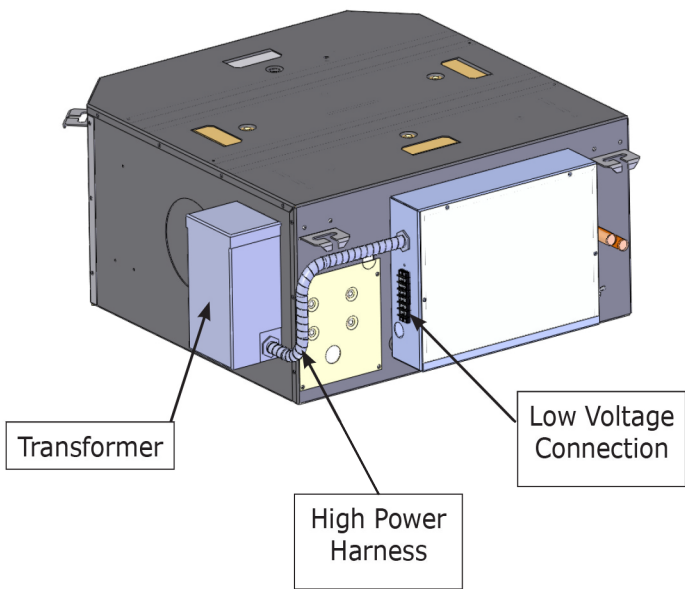
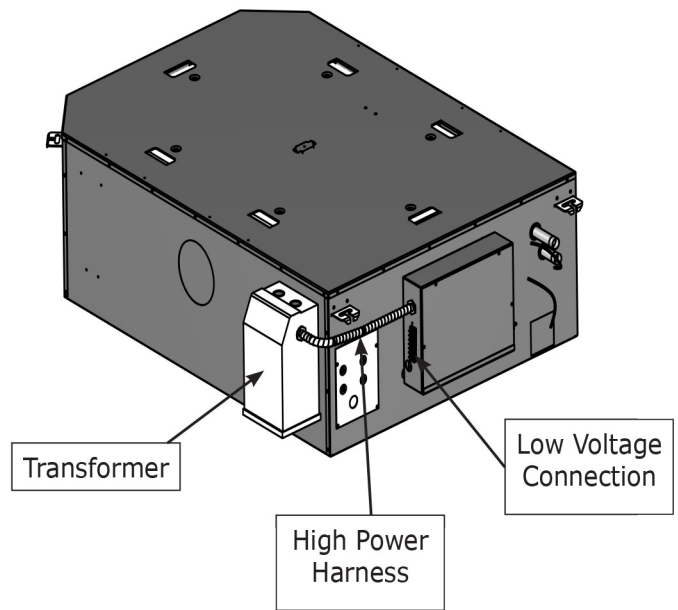

Figure 32 - CAW 33-36 Transformer Mounting



CAW Wall Mounted Thermostat Operation

Thermostat Selection

- Choose 24Vac, dry contact type thermostat that matches your application.
- EMI equipment is compatible with most standard bimetal, mercury bulb, digital electronic or power-stealing thermostats.
- Refer to Electrical Wiring for thermostat, chilled water valve and optional hot water valve wiring connections to CAW unit along with thermostat manufacturer's instructions for wiring and special operation or programming. See page 17.

1. Cooling Only Thermostat Selection

Select a thermostat compatible with chilled water cooling system and chilled water valve selected. Thermostat should have "R", "Y" and "G" terminals. Thermostat may also have "C" terminal.

2. Cooling with Electric or Hot Water Heat Thermostat Selection

Select thermostat compatible with chilled water cooling and hot water or electric heating system with water valve(s) selected. Thermostat should have "R", "Y", "W" and "G" terminals. Thermostat may also have "C" terminal.

Sequence of Operation Wall Mounted Thermostat

Follow all installation and electrical wiring instructions prior to applying power to the unit. If CAW unit is equipped option heating, either electric or hot water, verify thermostat is set to energize the fan with call for heating.

1. Fan Operation

Some thermostats are equipped with AUTO/ON fan switch. Placing switch ON will run the fan continuous. Placing switch in AUTO position will cycle the fan with call for heating or cooling through the "R" and "G" low volt terminal connections.

After thermostat is satisfied and call for heat or cooling is removed or the fan switch is set to auto the indoor fan will remain on for sixty (60) seconds to purge remaining energy from unit thereby increasing efficiency.

2. Cooling Operation

- A. Apply power to unit and place system switch in "COOL" mode. Adjust set-point temperature below room temperature. Chilled water valve will open and fan motor(s) will energize.

- B. Place set-point temperature above room temperature. Chilled water valve will close and fan remains on for additional sixty seconds.

2. Cooling with Electric Heat or Hot Water Heat Operation

- A. Set thermostat Configuration for cooling/electric heat operation. Follow thermostat manufacturer's instructions for configuration settings.
- B. Apply power to the unit and place system switch in "HEAT" mode. Adjust set-point temperature above room temperature. Electric heat will energize or hot water valve will open and fan motor(s) will energize.
- C. Place set-point temperature below room temperature. Electric heat will switch off or hot water valve will close and fan remains on for additional sixty seconds.

WARNING

Electrical shock hazard. Turn off power to unit before proceeding. Failure to follow these instructions could result in death or serious injury.

NOTICE

Unit is equipped with safety switch. Pump is activated when condensate reaches critical level. Safety switch disables cooling by closing water valve if water level becomes too high.

Verify Condensate Pump Operation

1. Remove adjacent ceiling tile to access condensate pump cover panel.
2. Insert squeeze water bottle nozzle through opening in condensate pump access panel and fill drain pan. See Figure 34.
3. Adding water activates float switch and pump. Water must flow regularly when condensate pump is energized. If water does not, check pipe slope or see if there are any pipe restrictions.
4. Verify all covers, panels and filters are in place and discharge louvers are correctly positioned.

Figure 33 - CAW Louver Toggle Switch - Sizes 18/20/30/36

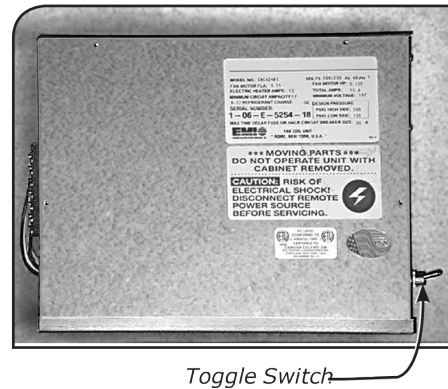

Figure 34 - Check Condensate Pump Operation



⚠ **WARNING**

Electrical shock hazard. Turn off power to unit before proceeding. Failure to follow these instructions could result in death or serious injury.

CAW- Infrared control system units only.

Set controller functions before proceeding with start-up. See instructions Page 27.

Test Cooling Operation

Unit operation is dependent on room temperature. It may be necessary to warm the room before testing unit's cooling abilities.

When power is first applied to control or after power outage there is three (3) minute delay before cooling or optional electric heat will energize. This is to protect unit from short cycling.

Perform Complete Inspection

System Electrical Verification

1. Turn off all power to unit.
2. Remove any tools or other obstructions.
3. Inspect all electrical connections.
4. Separate any lines that contact each other.
5. Replace control panel cover, filters and grilles.
6. Test each power and circuit connection before powering system.

Set DIP Switches

1. DO NOT turn power on until DIP switches have been set and control panel cover replaced.
2. Access DIP switches. Remove control panel cover. See Figure 35, Page 23 for location of switches on control board.
3. Infrared control system units have four DIP switches. See Table 3, Page 24.
 - A. DIP switch #1, Test mode, is used only during start-up and servicing, to reduce time required for automatic timers.

NOTICE

Do not place unit in service unless dip switch #1 is set to NO.

- B. DIP switches #2, #3 and #4 are related to (optional) use of wall mounted remote thermostat. Switches #2 and #3 are operational only if switch #4 is set to YES, enabling wall mounted remote thermostat operation.
4. Set switches as desired for application.

Set Controller Configuration

1. See Figure 37, Page 26 and Pages 24-34 for operation of controller and infrared control system handheld remote.
2. See Figure 37, Page 26 for information on setting control using IR handheld remote. IR hand held remote is a line-of-sight device, and must be pointed at receiver on unit-mounted display.
3. Turn power on to indoor unit so control is operational.
4. Press and hold both MODE and PROGRAM buttons on IR hand held remote for 5 seconds to enter Configuration mode. See Figure 37 Page 26.
5. Configure controller see Figure 38, Page 27.
6. Complete configuration. Point IR hand held remote toward cassette unit's display. Press and hold power button for 2 seconds. Information is transmitted from IR hand held remote to cassette. Cassette responds with beep, indicating it has received information. It is possible that information entered into IR hand held remote may not have been received if IR hand held remote was not pointed directly at receiver.
7. Set time and 7-day program after start-up is complete, not at this time.

Perform Electrical Circuit Checks

1. Turn power on to cassette unit.
2. Verify fan and louver operation using IR handheld remote. See Figure 37, Page 26.
 - a. Verify fan can be set to high, medium, low and auto.
 - b. Verify louver can be set to run at full open or oscillation 18 & 36.

Verify Cooling-Only Operation Using IR Hand Held Remote

1. Cooling-only with no heat source in cassette.
2. Set configuration for Heat Source OFF, Heat Pump OFF. See Figure 37, Page 26.
3. Use IR hand held remote to set MODE to Cool. See Figure 36, Page 25.
4. Use IR hand held remote to adjust setpoint temperature below room temperature.
5. Verify supply air is cooler than room air.

Verify Cooling - With Optional Electric Heat

1. This is cooling unit *with optional electric or hot water heat* option in the cassette unit.
2. Set configuration for Heat Source ON, Heat Pump OFF using IR hand held remote controls. See Figure 38, Page 27.
3. Use IR hand held remote to set MODE to Cool. See Figure 37, Page 26.
4. Use IR hand held remote to adjust setpoint temperature below room temperature at cassette unit.
5. Verify supply air is cooler than room air.
6. Use IR hand held remote to set MODE to Heat.
7. Use IR hand held remote to adjust setpoint temperature above room temperature. Observe three (3) minute minimum time off.
8. Verify heating is operational. Verify supply air is warmer than room air.
9. Use IR hand held remote to enable auto changeover between heat/cool.

NOTICE

Unit is equipped with safety switch. Pump is activated when condensate reaches critical level. Safety switch disables cooling if water level becomes too high.

Verify Condensate Pump Operation

1. Remove adjacent ceiling tile to access condensate pump cover panel.
2. Insert squeeze water bottle nozzle through opening in condensate pump access panel and fill drain pan. See Figure 34.
3. Adding water activates float switch and pump. Water must flow regularly when condensate pump is energized. If water does not, check pipe slope or see if there are any pipe restrictions.
4. Verify all covers, panels and filters are in place and discharge louvers are correctly positioned.

⚠ WARNING

Electrical shock hazard. Verify all power is off before removing control box cover. Failure to follow these instructions could result in death or serious injury.

Figure 35 - Cassette Control Panel

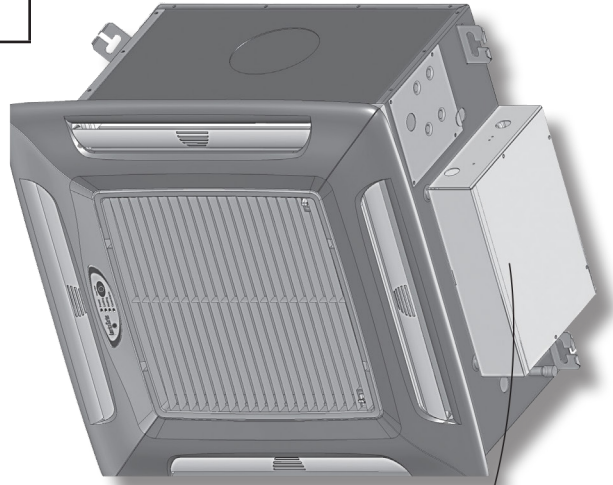

Dip Switches

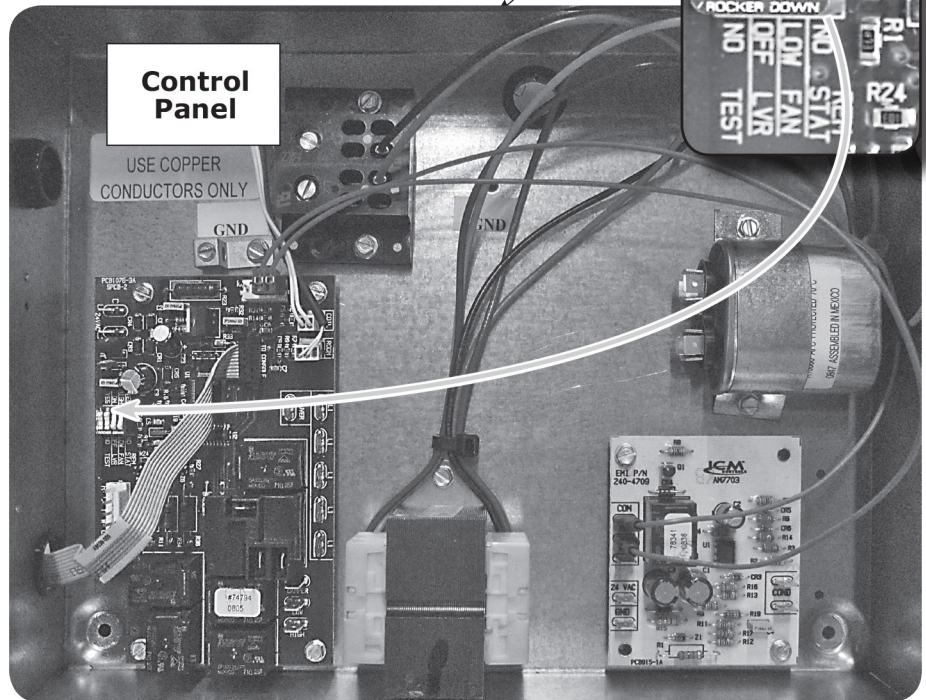
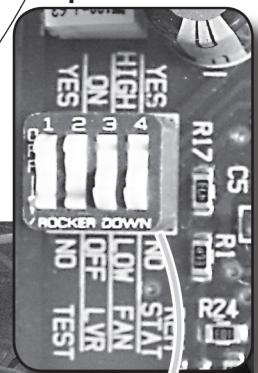

Not all wiring is in place for clarity.

Table 3 - CAW Microprocessor Controller — Dip Switch Settings

DIP Switch	Setting	Operation	Factory Setting
#1 Test mode	YES	Enables Test Mode. Timers are shortened, quick operational testing. <ul style="list-style-type: none"> • Anti-short-cycle time reduces from 3 minutes to 45 seconds. • Minimum on-time reduces from 2 minutes to 30 seconds. • Post-purge time reduces from 60 to 15 seconds. • Stagger start time reduces from 30 to 7.5 seconds. 	NO
	NO	Disables Test Mode.	
#2 Louver oscillation (for wall mounted thermostat mode only)	On	If DIP Switch #4 is YES, enables louver oscillation during operation.	OFF
	Off	If DIP Switch #4 is YES, disables louver oscillation during operation.	
#3 Fan speed setting (for wall mounted thermostat mode only)	HIGH	While DIP Switch #4 is YES, selects fan speed HIGH .	HIGH
	LOW	While DIP Switch #4 is YES, selects fan speed LOW .	
#4 Select infrared handheld controller or wall mounted thermostat control	YES	Disables infrared hand controller and enables wall mounted thermostat operation. Enables dip switches #3 and #2. Clean filter time automatically defaults to 1000 hours.	YES
	NO	Enables infrared hand controller and disables wall mounted thermostat operation.	

Figure 36 - CAW Unit-Mounted Receiver — Chassis-Mounted Display

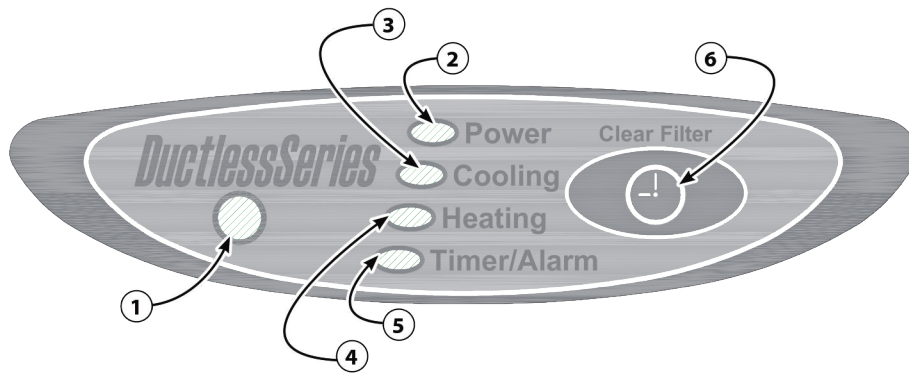

1	Infrared Receiver Window
	Power LED Wired wall mounted remote thermostat controller mode — on when power is applied to unit. Infrared Controller mode — on while cassette unit is in ON mode; off while unit is in OFF mode.
3	Cooling LED On when unit is in cooling operation.
4	Heating LED On during calls for heat.
5	Timer/Alarm LED On steady while unit is in sleep timer mode; flashes to indicate fault codes.
6	Clear Filter Warning Button Hold for 3 seconds to clear clean filter warning (indicated when timer/alarm LED, item 5, flashes 4 times)

Figure 37 - CAW Infrared Hand Held Control

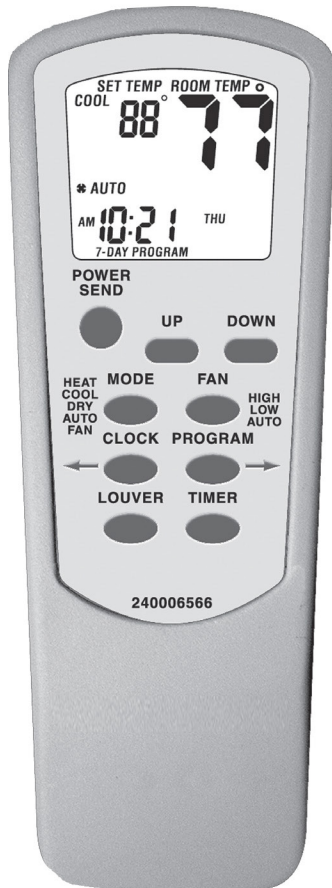

POWER SEND ●	Press to turn unit on or off. Press and hold for 2 seconds to transmit all settings to the unit-mounted controller.
MODE ●	Press to toggle through operating modes — heat, cool, auto change over, dry or fan.
CLOCK ●	Normal operation — hold for 3 seconds to enter set time mode ; press again to finish and exit. In programming mode — press to enter selection displayed.
LOUVER ●	CAW18 - CAW36 — press to toggle motorized louver on or off.
UP ●	Normal operation — press to increase setpoint temperature. Configuration, set time or programming mode — press to increase setting.
DOWN ●	Normal operation — press to decrease setpoint temperature. Configuration, set time or programming mode — press to decrease setting.
FAN ●	Press to toggle between fan modes — high, low or auto.
PROGRAM ●	Normal operation — press to toggle between manual operation and Pre-programmed (7-day) run mode. Configuration, set time or programming mode — press to enter next selection.
TIMER ●	Press to toggle timer mode on/off.
MODE + PROGRAM	With unit in OFF mode — Press and hold for 5 seconds to enter configuration mode ; press again to exit.
PROGRAM + CLOCK	Press and hold 3 seconds to enter 7-day programming mode ; press again to exit.
FAN + PROGRAM	With unit in 7-day programming mode — Press and hold 3 seconds to copy settings for selected day to all other days.

Figure 38- Configuration Settings CAW

Setting Item	Display	Possible Value (flashing)	Factory Settings	Overview	
<p><i>To access:</i> Press MODE and PROGRAM together for 5 seconds, repeat to exit <i>Navigating through settings:</i> Press PROGRAM to move to next setting or CLOCK to move to previous setting. To change values, use UP and DOWN keys; when value is reached, move to next setting using PROGRAM or CLOCK button; values are stored on exit from programming mode.</p>					
Temperature Scale	01 F-C	F C	Fahrenheit Celsius	F	Select temperature scale for display and operating settings.
Heat Source	02 HEAT	ON OFF	Available Not available	See (Note 3)	Set to ON if unit is equipped with electric heater option. Electric heater is required for automatic changeover operation.
Heat Pump (see Note 1)	03 H-P	ON OFF	Available Not available	OFF	N/A Set to OFF all all CAW units
Auto Changeover Differential (see Note 2)	04 d-b	x	2° - 6°	2°	Auto changeover automatically operates unit in heating or cooling based on room temperature versus setpoint. <i>Setting is dead band temperature:</i> <ul style="list-style-type: none"> Cooling is on while room temperature is at setpoint PLUS dead band. Heating is on while room temperature is at setpoint MINUS dead band. Example: setpoint = 68°F, dead band is 3°F — cooling is on with room temperature at or above 71°F — heating is on with room temperature at or below 65°F.
Check Filter Time	05 F:Lt	2 5 7 10 12	250 hours 500 hours 750 hours 1000 hours 1250 hours	10	Set time for automatic notice of time to change filter. At end of time period, control displays FILTER CHECK warning. Warning appears if four (4) coil freeze-ups occur in 24-hour period. Reset warning, restart time period, by pressing MODE and FAN buttons together for 3 seconds.
<p>Note 1: Setting 03, Heat pump is SKIPPED if setting 02, Heat source, is OFF. Note 2: Setting 04, Auto changeover is SKIPPED if setting 02, Heat source, is OFF. Setting is for operation with handheld controller. Note 3: Factory setting is ON if electric or hot water heat is installed in unit, or OFF if electric or hot water heat is not installed.</p>					

Figure 39 - 7-Day Programming Options For CAW

Item	Setting	Values	Overview
<p>To access: Press and hold PROGRAM and CLOCK buttons simultaneously 3 seconds; use arrow keys to select position; save selection and exit by repeating button press.</p>			
<p>Quick copy — Hold FAN and PROGRAM buttons 3 seconds to copy current day's settings to all other days.</p>			
<p>Navigating through settings: Press PROGRAM to move to next setting or CLOCK to move to previous setting; to change values, use UP and DOWN keys; when value is reached, move to next setting using PROGRAM or CLOCK button; values are stored on exit from programming mode.</p>			
<p align="center">7-Day Programming (See Table 4, Page 30 to record settings)</p>	Day of week	Mon, Tue, Wed, Thu, Fri, Sat, Sun	Louver is closed when fan is off.
	Period of day	Morning Day Evening Night	<p>Periods provide four time settings to initiate change in cooling/heating setpoints.</p> <p>Allow adjustments for setback (such as night setback, daytime setback and occupied settings for residential applications).</p> <p>Set hour/minute for each time as well as cooling and heating setpoints below.</p>
	Hour	0-12 a 0-12 p	Set time to begin period.
	Minute	0-59	
	Cooling setpoint	55-90 F	Default setpoint when set to Cooling in pre-programmed run mode.
	Heating setpoint	55-90 F	Default setpoint when set to Heating in pre-programmed run mode.
	Auto setpoint	55-90 F	Unit default setpoint when set to Auto in pre-programmed run mode. (Unit auto change over between heating and cooling.)

Table 4 - CAW Microprocessor Controller — Dip Switch Settings

		Morning			Day			Evening			Night		
		Auto	Heat	Cool	Auto	Heat	Cool	Auto	Heat	Cool	Auto	Heat	Cool
Monday	Time	:			:			:			:		
	Temp												
Tuesday	Time	:			:			:			:		
	Temp												
Wednesday	Time	:			:			:			:		
	Temp												
Thursday	Time	:			:			:			:		
	Temp												
Friday	Time	:			:			:			:		
	Temp												
Saturday	Time	:			:			:			:		
	Temp												
Sunday	Time	:			:			:			:		
	Temp												

To copy the settings from any day to the entire week

1. Select the day to be copied.
2. Simultaneously press the **"FAN"** and **"PROG"** buttons for three seconds

Handheld Remote Operation

- When power is first applied to control or after power outage, there is three (3) minute delay before cooling or heating begins. Protects unit from short cycling due to loss of power.
- Configure controller with remote DIP switch 4 to NO to operate using IR hand held remote controller. DIP switch YES to operate using wall mounted remote thermostat. See Table 3, Page 24.
- Point IR hand held remote toward cassette's infrared receiver window when entering commands. Cassette responds with beep indicating it has successfully received transmitted information. See Figure 36, Page 24.

Synchronization

IR hand held remote and cassette's main control board mode synchronization are not in same mode may happen if commands are entered into remote when not pointed at cassette.

To re-synchronize:

- Enter any command into IR hand held remote while pointing at cassette's infrared receiver window.
- Alternatively, hold POWER/SEND button two seconds. All optional IR hand held remote's settings are transmitted to cassette. Cassette responds with beep, indicating it received transmitted information.

Temperature Indication

- Room temperature displayed on IR hand held remote is temperature at IR hand held remote.
- Microprocessor control located in cassette does not read IR hand held remote's temperature — it uses sensor located in return air of cassette.
- Warming or cooling of IR hand held remote alone does not effect operation of cassette. Cassette reacts to its local temperature sensing element and setpoint selected and transmitted by IR hand held remote.

Transmission Limits

- Transmission distance of IR hand held remote is approximately 25-30 feet when perpendicular to face of cassette.
- Reception distance varies with angle of transmission if not perpendicular.
- Reception distance may also vary depending on room lighting.

Hibernate Mode

- When IR hand held remote enters hibernate mode, display goes dark if no activity on IR hand held remote for ten minutes.
- Pressing any button awakens IR hand held remote while in hibernate mode. IR hand held remote returns to mode it was in prior to entering hibernate mode.

Power

Pressing POWER button momentarily switches unit either on or off.

1. OFF mode, LCD displays time of day and day of week.
2. ON mode, LCD displays room temperature, mode of operation cooling, heating, auto (auto changeover), dry or Fan mode.
3. ON mode, setpoint temperature displays momentarily with push of any button except POWER button.
4. IR hand held remote transmits all infrared hand held controller information to cassette when POWER is held down for two (2) seconds.

Mode

- Heating, auto changeover (auto) or dry modes do not display if heat source is set to OFF in configuration mode.
- MODE button allows selection of mode of operation — cooling, heating, auto changeover (ACO), dry or fan mode.
- Fan mode either HIGH or LOW appears on LCD.

Fan Operation

Unit utilizes two-speed motor with three operational fan modes — high, low, and auto. All modes are continuous fan operation.

FAN button allows selection of desired fan speeds in all modes except Dry mode.

Dry mode, fan operates constantly at low speed. LCD indicates fan speed selection. High and low are constant fan settings. Fan operates continuously, regardless of setpoint or room temperatures.

Auto fan mode is for auto ramping of fan speeds.

1. Auto fan mode can only be selected if unit is in heating, cooling or auto changeover modes.
2. Auto fan mode, speed is determined by microprocessor.
 - a. Speed adjustment is made according to room and setpoint temperatures.
 - b. Fan switches to High speed when room temperature deviates by more than two degrees from setpoint.
 - c. Fan switches to Low speed if deviation is one degree or less.

Louver Operation — CAW18-36

Louver can be set to oscillate during fan operation or open to fixed setting.

"Lou" is displayed for two seconds along with "ON" or "OFF" to indicate louver setting has been changed when LOUVER is pressed.

Cooling Mode

For cooling operation, turn unit on via POWER button.

1. Select Cooling mode via MODE button.
2. Room temperature and set point temperature are displayed.
3. Setpoint temperature changes by one degree with each successive press of UP or DOWN ARROW buttons. Holding button in changes temperature rapidly.
4. Place setpoint temperature below room temperature.
5. Three (3) minutes after turning on power, cooling starts and continues for minimum of two (2) minutes and continues cooling as long as setpoint remains below room temperature.
6. Cooling LED illuminates as long as unit is calling for cooling.
7. Once room temperature is satisfied for at least sixty (60) seconds and two (2) minute minimum run time has elapsed, cooling cycles off.
8. Fan operates as described in Fan Operation. See Page 30.
9. Once cooling has cycled off or following power outage, cooling does not restart for at least three (3) minutes (anti-short-cycle timer).

Optional Heating Mode**Optional Electric Or Hot Water Heat Operation**

For operation with optional electric or hot water heat control must be configured properly (Heat Source – ON, Heat Pump – OFF. See Figure 37, Page 26.

For electric or hot water heat operation, turn unit on via POWER button.

1. Select Heating mode via MODE button.
2. Room temperature and setpoint temperature are displayed.
3. Press either UP or DOWN ARROW buttons to change setpoint temperature.
4. Setpoint temperature changes one degree with each successive press of UP or DOWN ARROW buttons. Holding button down will changes temperature rapidly.
5. Place setpoint temperature above room temperature.
6. Electric or hot water heat energizes and heating continues as long as setpoint remains above room temperature.
7. Heating LED illuminates as long as unit is calling Heating mode.
8. When room temperature is satisfied for sixty (60) seconds and two (2) minute minimum on-time has expired, electric heat switches off.
9. See Fan Operation, see Page 30.

Dry Mode

Dry mode removes humidity from air while maintaining specific setpoint temperature. This is done by cycling cooling mode. Dry mode will NOT maintain specific humidity level. Fan remains on continuously at low speed while in Dry mode.

Dry mode operation, turn unit on via POWER button.

1. Select Dry mode via MODE button.
2. Room temperature and setpoint temperature are displayed.
3. Press either UP or DOWN ARROW buttons to change setpoint temperature.
4. Setpoint temperature changes one degree with each successive press of UP or DOWN ARROW buttons. Holding button down will change temperature rapidly.
5. Place setpoint temperature at desired room temperature.
6. Depending on difference between room temperature and setpoint temperature, water valve will either remain open continuously, cycle open/closed, or remain closed.
7. If room temperature is greater than setpoint temperature by more than two (2) degrees, unit runs Cooling mode continuously .
8. If room temperature is within \pm two (2) degrees of setpoint, unit cycles cooling on seven (7) minutes and off seven (7) minutes to remove humidity from air while not over cooling room.
9. If room temperature is less than setpoint temperature by more than two (2) degrees, cooling remains off.

Auto Changeover Mode - Optional Electric or Hot Water Heat Required

Auto changeover mode (ACO), unit must have heat source. Control must first be configured properly, heat source – ON. See Figure 37, Page 26.

Auto changeover mode, cassette will operate in either Cooling mode or Heating mode. Control selects mode of operation dependent upon setpoint temperature, room temperature and differential setting selected in configuration mode.





Auto changeover mode, turn unit on via POWER button.

1. Select Auto mode via MODE button.
2. Room temperature and setpoint temperature are displayed.
3. Press either UP or DOWN ARROW buttons to change setpoint temperature.
4. Setpoint temperature changes one degree with each successive press of UP or DOWN ARROW buttons. Holding button down changes temperature rapidly.
5. Place setpoint temperature below room temperature by auto change over differential amount selected in Configuration mode.

6. Cooling starts. Unit runs cooling operation as described in Cooling mode.
7. If setpoint temperature is above room temperature by auto change over differential amount selected in Configuration mode, unit runs heating operation as described in Heat mode.

Set Time Mode







Clock used by 7-day programming mode.

1.  CLOCK button is used to enter or exit Set Time mode.
2. Set Time mode can be entered while control is in any mode, including Off mode.
3. To enter Set Time mode, press  CLOCK button for three (3) seconds.
4. Pressing  PROGRAM button advances to next item.
5. Order is (1) Day of week, (2) Hour and (3) Minute.
6. Time of day and day of week are changed using UP or DOWN ARROW buttons.
7. When  CLOCK button is pressed again or left idle for twenty (20) seconds, control saves new settings and returns to previous mode.

Unit will not automatically adjust for Day Light Savings time.

7-Day Programming Mode

7-day Programming mode is used to store settings for Pre-Programmed Run mode.

1. When unit is in either Off or On mode, 7-Day Programming mode can be entered by pressing PROGRAM  +  CLOCK buttons simultaneously for three (3) seconds.
2. When PROGRAM  +  CLOCK buttons are pressed simultaneously again or left idle for twenty (20) seconds, control saves new settings and returns to previous interface mode.
3. While in 7-Day Programming mode, words "7-DAY PROGRAM" are displayed on LCD.
4. Use UP or DOWN ARROW buttons to change time, temperature or period settings.
5. Use  CLOCK or PROGRAM  buttons to select mode to be changed.
6. Settings can be entered for:
 - a. Day of week
 - b. Period of day
 - c. Hour
 - d. Minute
 - e. Cooling setpoint temperature
 - f. Heating setpoint temperature
 - g. Auto setpoint temperature. Quick Copy

Quick Copy

Quick copy is feature of 7-Day Programming mode, used to copy settings of any day to rest of week.

While in 7-Day Programming, select day to be copied. Press FAN + PROGRAM  buttons simultaneously for three (3) seconds. Selected day is copied to rest of week.

Manual Run Mode

Normal operating non Pre-Programmed Run mode. Settings for temperature, mode and fan speed are selected by user and do not change with time. Word "PROGRAM" does NOT display on LCD.

Pre-Program Run Mode

Feature allows setpoint temperature to be changed according to pre-programmed setpoint and time of day settings.

Setpoint and time settings are programmed into control through 7-Day Programming mode.

1. Pre-Programmed Run mode is entered from Cooling mode, Heating mode or Auto mode only.
2. Pre-Programmed Run mode cannot be entered from Dry or Fan modes.
3. Pressing PROGRAM  button momentarily enters or exits Pre-Programmed Run mode.
4. The word "PROGRAM" appears in LCD display.
5. The setpoint changes to programmed setting at selected time.

To use Pre-Programmed Run mode enter program settings through 7-Day Programming mode.

1. Select mode of operation (Cooling, Heating, Auto) and press PROGRAM  button to enter Pre-Program Run mode.
2. As time passes, setpoint temperature is selected according to time of day and 7-Day Program settings.
3. To override setpoint while in Pre-Programmed Run mode, adjust temperature using UP or DOWN ARROW buttons. Override setting will remain in effect until next scheduled event. (Morning, Day, Evening, Night) Setpoint is value selected in 7-Day Programming mode.

Clean Filter Alarm

Cassette controller indicates when scheduled filter cleaning is required by flashing Timer/Alarm LED. During normal operation, microprocessor keeps track of units run time.

1. Timer/Alarm LED flashes four times to indicate filter needs to be cleaned.
2. Clean filter time is selected through Configuration mode.
3. Available settings are 250, 500, 750, **1000**, and 1250 hours. Default in **Bold**.
4. If coil freeze condition is detected four times within 24-hour period, Clean Filter Alarm appears.

After filter maintenance has been performed, press Mode & Fan button for three (3) seconds. Control responds with beep to indicate timer has been reset.

Sleep Timer

Sleep timer feature allows user to switch unit off using preset timer. When control is in On mode, pressing TIMER button enters or exits Sleep.

Timer Mode (IR Hand Held Remote or Wall Thermostat).

When in Sleep Timer mode, word "TIMER" appears on LCD display. Unit continues to operate for thirty (30), minutes, then switches off. No adjustment.

To turn unit back on, press POWER button momentarily.

Configure infrared handheld remote to wall mounted remote thermostat

Wall mounted remote thermostat operation configure control through DIP switches located on control board located in control box.

- Set DIP switch #4 to YES. See Table 3, Page 24.
- When set to "Wall mounted remote thermostat mode" control will not accept commands from infrared remote control.
- Filter check timer defaults to 1000 Hrs.

Fan Operation

Cassette unit utilizes 2 speed motor. In wall mounted remote thermostat controller operation, fan speed selection can be made through Fan DIP switch. See Pages 23 and 24.

- DIP switch #3 set to HIGH, fan speed is set to High.
- DIP switch #3 set to LOW, fan speed is set to Low.
- See Table 3, Page 25 for other available DIP switch selections.

Clean Filter Alarm (Wall Thermostat Mode) CAW

Cassette controller indicates when scheduled filter cleaning is required by flashing Timer/Alarm LED.

During normal operation, microprocessor keeps track of unit's run time.

- When clean filter time has elapsed, Timer/Alarm LED flashes four times to indicate filter needs to be cleaned.
- Clean filter time is selected through configuration menu. Available settings are 250, 500, 750, **1000**, and 1250 hours. Default in **Bold**.
- If coil freeze condition is detected four times within 24-hour period, Clean Filter Alarm appears on cassette display.

After filter maintenance has been performed, press Mode and Fan Buttons for three (3) seconds. Control responds with beep to indicate timer has been reset.

Minimum Run Time

Minimum on-time prevents cooling or heat source from cycling off prematurely. Minimum on-time for cooling and electric heat is two (2) minutes.

LCD Back Light

LCD display can be illuminated using LCD back light feature. Selectable settings are Off, On, and Intermittent, and are set in Configuration.

- Selecting OFF, backlight remains off.
- Selecting ON, backlight remains on at all times, including while in Off mode interface.
- Intermittent, backlight remains ON for 10 seconds after the push of any button while control is in On mode or after push of ON/OFF button while in Off mode interface.

Drain Pan Sensor

Drain pan sensors monitor condensate level in each units drain pans. Should water in either pan reach critical level, monitor automatically signals main control unit.

Microprocessor will switch off the water valve unit for minimum of three minutes until fault condition has been cleared, to prevent further condensate production. Fault code, E02, then flashes on controller's LCD display and automatically resets once fault condition is cleared.

Annunciation

- Controller beeps, providing audio feedback confirming microprocessor has received its commands.
- Annunciation feature must be activated in configuration. Selections are OFF and ON.
- OFF - annunciation remains off.
- ON - annunciation beeps with push of any button in On mode or with push of ON/OFF button while in off mode.

Memory Backup

Control retains all settings, including mode of operation in event of power failure.

When power is restored, control returns to mode of operation settings prior to power failure, after three (3) minute time delay.

Table 5 - Microprocessor Controller Fault Indications For Infrared Control System

Timer/Alarm LED – number of flashes:	Fault Condition	Description
1	Room Air Sensor Fault	If room air sensor is disconnected, damaged or malfunctions Timer/Alarm LED will flash one (1) time to signify that fault has occurred. Operation of heating and cooling stop. Fan will continue to operate.
2	Condensate Fault	If control senses condensate fault condition, either through condensate pumps safety switch or drain pan sensors, Timer/Alarm LED flashes two (2) times to signify fault has occurred. Cooling switches off for minimum of three (3) minutes AND fault condition is corrected. After, as long as the thermostat is calling for cooling the water valve will open and cooling starts.
3	ID Coil Sensor Fault	Indoor coil sensor monitors temperature of indoor coil. If freeze condition is detected continuously for three (3) minutes, Timer/Alarm LED flashes three (3) times to signify fault has occurred. Cooling switches off for minimum of three (3) minutes AND fault condition is corrected. If microprocessor detects coil freeze condition four (4) times within 24 hour period, clean filter indicator appears.
4	Clean Filter	To aid in filter maintenance, cassette controller indicates when schedule filter cleaning is required by flashing Timer/Alarm LED. During normal operation microprocessor will keep track of unit's run time. When clean filter time has elapsed, Timer/Alarm LED flashes four (4) times to indicate filter needs to be cleaned. Clean filter time is can be selected through Configuration mode. Available settings are 250, 500, 750, 1000, and 1250 hours. In wall mounted thermostat mode, default time is 1000 hrs. This cannot be changed. If coil freeze condition is detected four (4) times within 24 hour period, Clean Filter Alarm will appear. After filter maintenance has been performed, press Clear Filter Warning Button for three (3) seconds. Control responds with beep to indicate t timer has been reset.
5	Test Mode	See Table 3, Page 25 for information.

Auxiliary Freeze Protection for Chilled Water and Hot Water Coils.

CAW units are equipped with a secondary capillary type freeze sensor to guard against coil freeze up due to sub-freezing ducted fresh air or cold room ambient conditions.

The sensor is mounted on the supply side of the outer most coil of the CAW unit. Depending on the model selected the freeze sensor will either switch off the fan or energize heating mode should a freeze condition be detected. Once the freeze condition is alleviated the sensor will reset and the CAW unit will return to normal operation.

⚠ WARNING

Electrical shock hazard. Before removing access panels, verify all power is disconnected from unit. Failure to follow these instructions could result in death or serious injury.

Have service performed by qualified service agency.

Clean Filter

1. Clean air filter monthly.
 - a. Access filters by removing air intake access grilles. See Figure 40.
 - b. Remove filter by carefully twisting and lifting to clear retaining clips. See Figure 41.
 - c. Lift filter off grille. Place filter on flat surface and vacuum any dust and debris. Vacuum all filters and grilles. Vacuum any accessible unit parts. See Figure 42.
 - d. Or use garden hose:
 - Wash grille and filter with hose.
 - Let filters and grilles dry before replacing.

⚠ WARNING

DO NOT operate unit without filter and front grille in place.

- e. Replace filters, clips and front grille before operating unit. Replace filters by sliding under retainer clips.)
- f. Wipe with damp cloth when needed. See Figure 43.

Figure 40- Remove Grille



Figure 41 - Remove Filter



Figure 42 - Clean With Vacuum



Figure 43 - Clean With Damp Cloth



WARNING

Electrical shock hazard. Before removing access panels, verify all power is disconnected from unit. Failure to follow these instructions could result in death or serious injury.

Wiring Diagram

Troubleshooting indoor unit, see wiring diagram(s) supplied with equipment.

- Wiring diagram located on inside surface of control panel cover. See Figure 27, Page 17.

Wiring Requirements

- Air handler may be protected by separate time delay fuse or HACR breakers. See unit name plate for correct breaker type and size.
- Transformer provides low-voltage power source for controls. Interconnect wire should be at least 18 awg.
- See unit wiring diagram for interconnect diagram that matches your system.

Power Supply Check

Check rating plate for proper field voltage and breaker size.

Use voltmeter to check incoming power supply. Verify power supply agrees with rating plate.

- Incoming power must not exceed name plate voltage.
- Incoming power must not be below minimum voltage stated on rating plate (197Vac for units rated 208/230Vac).

Wall Mounted Thermostat - CAW Units

Low volt interface requires 18 AWG low-voltage interconnecting wires.

- Terminal "W" is required for units with electric or hot water heat only.
- Terminal "C" may not be needed on some thermostats.
- Wall mounted thermostat controls **cooling** through black, "Y," and "C" wires.
- Wall mounted thermostat controls **heating** through white, "W," and "C" wires.

When thermostat is calling for cooling, 24Vac is measured across terminals:

- "Y" and "C" of water valve.
- "Y1" and "C" of cassette.

While wall thermostat is calling for cooling or heating and anti-short-cycle-timer delay has elapsed, 24Vac can be measured between terminals:

- "Y" and "C" of water valve for cooling.
- "Y1" and "C" cassette for cooling.
- "G" and "C" cassette (fan signal).
- "W" and "C" for heating.

Electric Heat (Optional)

Units with electric heat utilize control relay located on circuit board in control box. Wall mounted thermostat calling for electric heat relay energizes.

To verify electric heat operation, place wall thermostat in Heat mode with setpoint temperature above room temperature.

- Place clamp-on type ammeter on one leg of incoming power supply.
- When unit is working correctly, amp reading should correspond with values in table below.
- Following current values apply when unit is connected to 230Vac power supply. Values include fan motor current. If supply voltage is different, this will affect amp draw of heater.

5kW = 22.7 A	3kW = 13.6 A	1.5kW = 6.9 A
---------------------	---------------------	----------------------

- Electric heat relay can also be verified by placing voltmeter across high-voltage relay output terminal and incoming power L2 terminal.
- If unit is working correctly, reading should be same as measured across incoming power supply.

Auto-Reset Limit Switch

As safety feature, an auto-reset limit switch is located on heater assembly.

- Limit will interrupt power to heater if over-temperature condition occurs.
- Each limit switch is also equipped with one-time fuse link.
- Should electric heat temperatures rise above auto resetting limit switch, non-resetting, one-time fuse link will open and heater will remain off.
- If this occurs limit switch assembly must be replaced.

WARNING

Electrical shock hazard. Before removing access panels, verify all power is disconnected from unit. Failure to follow these instructions could result in death or serious injury.

Checking Fuse Link

To verify if fuse link has failed requires an Ohmmeter reading across the limit switch.

1. After disconnecting all power to unit, disconnect wires from limit switch.
2. With ohmmeter, check continuity across limit switch.
3. If limit switch is open, it must be replaced.

For optional wall thermostat operation, 24Vac can also be measured across Cassettes low-voltage terminals:

- "G" and "C" (fan signal).
- "W" and "C" (electric heat signal).

CAW Infrared Control System

Cooling only units require 18 AWG minimum low-voltage interconnecting wires.

- Terminal "W" is required for units with electric or hot water heat only.
- Cassette controller will switch chilled water valve on and off through yellow, "Y," low-voltage terminal and hot water through white, "W" and "C".
- When unit is calling for cooling, 24Vac can be measured across terminals "Y" and "C" of unit.
- When unit is calling for hot water heating, 24Vac can be measured across terminals "W" and "C".
- Indoor unit contains electronic anti-short-cycle timer feature (ASCT) that will prevent unit from short cycling. After room temperature is satisfied there will be three-minute delay before unit is allowed to restart.
- Cassette controller or wall thermostat will also control indoor fan by switching high-voltage power to fan motor with fan relay. When energized, high-voltage power can be measured between relay output and L2 terminal of incoming power supply.
- For optional wall thermostat operation, 24Vac can also be measured across low-voltage terminals "G" and "C" of cassette.

Figure 44 - Low-Voltage Interconnections - Wall Mounted Remote Thermostat

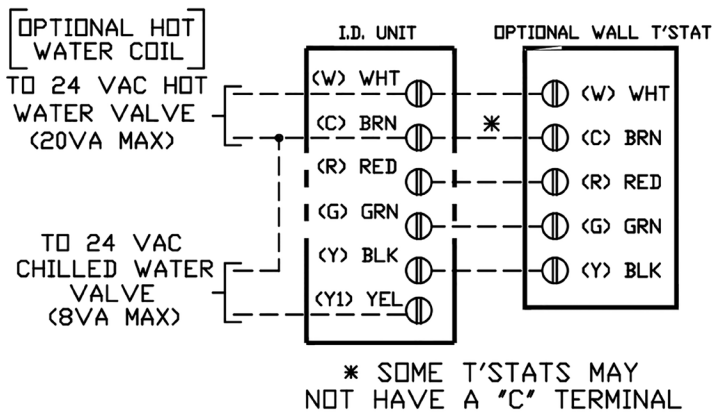
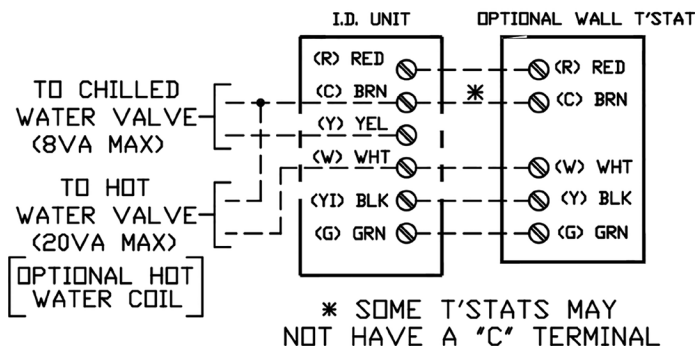

Figure 45 - Low-Voltage Interconnections - IR Handheld Remote Controls with Optional Wall Mounted Thermostat



SPECIFICATIONS & SYSTEM PERFORMANCE

Table 6 - Electrical Specifications

	Model	Fan Motor			Elect Heat		Total Amps	Min Volt	M.C.A.	HACR BRKR
		Volts/Hz/Ph	RLA	H.P.	kW	Amps				
60 Hz	CAW 08/12	115/60/1	0.9	1/10	-	-	0.9	104	1.2	
	CAW 08/12	208/230/60/1	0.35	1/10	-	-	0.4	197	0.5	15
	CAW 08/12	208/230/60/1	0.35	1/10	1.5	6.52	6.9	197	8.6	15
	CAW 18/20	115/60/1	1.1	1/8	-	-	1.1	104	1.4	15
	CAW 18/20	208/230/60/1	0.55	1/8	-	-	0.6	197	0.7	15
	CAW 18/20	208/230/60/1	0.55	1/8	3	13.04	13.6	197	17.0	20
	CAW 33/36	115/60/1	1.0, 1.0	1/10, 1/10	-	-	2.0	104	2.3	15
	CAW 33/36	208/230/60/1	0.5, 0.5	1/10, 1/10	-	-	1.0	197	1.2	15
	CAW 33/36	208/230/60/1	0.5, 0.5	1/10, 1/10	5	21.7	22.7	197	28.3	30

	Model	Fan Motor			Elect Heat		Total Amps	Min Volt	M.C.A.	HACR BRKR
		Volts/Hz/Ph	RLA	H.P.	kW	Amps				
50 Hz	CAW 08/12	220/240/50/1	0.35	1/10	-	-	0.4	198	0.4	15
	CAW 08/12	220/240/50/1	0.35	1/10	1.56	6.8	7.2	198	0.5	15
	CAW 18/20	220/240/50/1	0.55	1/8	-	-	0.6	198	0.7	15
	CAW 18/20	220/240/50/1	0.55	1/8	3.2	13.06	14.2	198	17.7	20
	CAW 33/36	220/240/50/1	0.5, 0.5	1/10, 1/10	-	-	1.0	198	1.2	15
	CAW 33/36	220/240/50/1	0.5, 0.5	1/10, 1/10	5.4	22.7	23.7	198	29.6	30

Table 7 - Shipping Weights

Model	Shipping Weight lbs (kg)
CAW 08/12	70 (31.8 kg)
CAW 18/20	108 (49.1 kg)
CAW 33/36	146 (66.4 kg)

Table 8 - Indoor Sound Levels (dBa)

Model	High Speed	Low Speed
CAW 08/12	41	39
CAW 18/20	44	42
CAW 33/36	51	49

CAW TECHNICAL DATA			
CONNECTIONS	08/12	18/20	30/36
CHILLED WATER INLET	5/8"	7/8"	7/8"
CHILLED WATER OUTLET	5/8"	7/8"	7/8"
CONDENSATE	1/2"	1/2"	1/2"
BRANCH DUCT DIAMETER	5"	5"	6"
FRESH AIR DUCT DIAMETER	3"	3"	3"
FILTRATION	08/12	18/20	30/36
TYPE	WIRE FRAMED PERIFRAME		
QUANTITY	1	2	3
ARRESTANCE	80%	80%	80%
CONDENSATE PUMP	08/12	18/20	30/36
MAXIMUM HEAD	30"	30"	30"
NOMINAL FLOW RATE (GPM)	0.1	0.1	0.1

SPECIFICATIONS & SYSTEM PERFORMANCE

CHILLED WATER 2-PIPE CASSETTE COOLING CAPACITIES

COOLING CAPACITY		CHILLED WATER ENTERING / LEAVING TEMPERATURE °F (no glycol)								Air Flow
MODEL	Entering Dry Bulb Air Temperature (°F) at 50% RH	40/50° F				45/55° F				
		Total Capacity	Sensible Capacity	Flow Rate	Pressure Drop	Total Capacity	Sensible Capacity	Flow Rate	Pressure Drop	
		Btuh	Btuh	GPM	FT. Water	Btuh	Btuh	GPM	FT. Water	
08	72	7,700	7,300	1.5	3.3	5,900	5,900	1.2	2.0	360
	75	9,100	8,000	1.8	4.5	7,200	6,900	1.4	2.9	
	80	12,900	9,400	2.6	8.6	9,600	8,100	1.9	4.9	
12	72	10,500	8,900	2.1	1.9	7,400	7,200	1.5	0.9	360
	75	12,700	9,900	2.5	2.9	9,300	8,400	1.9	1.5	
	80	17,700	11,700	3.5	5.4	13,500	10,000	2.7	3.2	
18	72	11,800	11,800	2.3	0.6	9,000	9,000	1.8	0.4	650
	75	15,900	14,300	3.2	1.0	10,700	10,700	2.1	0.5	
	80	24,000	17,700	4.8	2.5	18,000	15,100	3.6	1.3	
20	72	12,300	12,300	2.4	0.6	9,300	9,300	1.9	0.4	700
	75	17,200	15,400	3.4	1.2	11,200	11,200	2.2	0.5	
	80	27,200	19,400	5.4	3.2	19,400	16,300	3.9	1.6	
33	72	26,700	22,900	5.3	2.7	19,200	18,800	3.8	1.3	950
	75	33,300	25,800	6.6	4.4	23,900	21,700	4.8	2.2	
	80	50,300	32,400	10.0	9.4	36,800	26,700	7.3	5.2	
36	72	30,500	26,300	6.1	3.7	21,900	21,500	4.4	1.8	1100
	75	39,700	30,400	7.9	6.1	27,300	24,900	5.5	2.9	
	80	58,400	37,600	11.6	12.5	42,500	31,200	8.7	7.2	

50 Hz No Derate - 115v Transformer no Derate

2-PIPE CASSETTE

Model	Air Flow	
	High Speed	Low Speed
	CFM	CFM
CAW08	360	300
CAW12	360	300
CAW18	650	550
CAW20	700	600
CAW33	950	750
CAW36	1100	900

CAW HOT WATER 4-PIPE CASSETTE CAPACITIES

HOT WATER ENTERING TEMPERATURE 180°F

Model	Room Conditions	Heating Capacity Btuh	Water Flow GPM	Leaving Water Temperature	P.D. Ft. H ₂ O
CAW08	70 °F DB	13,300	1.4	160 °F	2.8
	50% RH	10,000	0.5	*140 °F	0.5
CAW12	70 °F DB	17,000	1.8	160 °F	1.6
	50% RH	13,500	0.7	140 °F	0.5
CAW18	70 °F DB	29,800	3.2	160 °F	2.8
	50% RH	22,500	1.2	140 °F	0.2
CAW20	70 °F DB	30,800	3.5	160 °F	2.8
	50% RH	23,200	1.2	140 °F	0.2
CAW33	70 °F DB	49,500	5.4	160 °F	8.3
	50% RH	37,800	2.1	140 °F	2.3
CAW36	70 °F DB	53,900	5.6	160 °F	9.2
	50% RH	40,600	2.2	140 °F	2.3

* 140°F Leaving water temperature data is in accordance with ANSI/AHRI Standard 440-2008

EMI  **Ductless**
Comfort Where It Counts.

2201 Dwyer Avenue,
Utica NY 13501
1-800-228-9364
fax 1-800-232-9364
website: www.enviromaster.com