

**NATURAL DRAFT CAST IRON SERIES II
GAS FIRED BOILERS FOR FORCED HOT WATER
NATURAL GAS TO LP CONVERSION
MGB/OMGB/MCB/DXL SIZES THROUGH 200 MBTU
Kit #'s 550002663, 550002664, 550002665**

⚠ WARNING

This conversion kit shall be installed by a qualified service agency in accordance with the manufacturer's instructions and all applicable codes and requirements of the authority having jurisdiction. If the information in these instructions is not followed exactly, a fire, an explosion or production of carbon monoxide may result causing property damage, personal injury or loss of life. The qualified service agency is responsible for the proper installation of this kit. The installation is not proper and complete until the operation of the converted appliance is checked as specified in the manufacturer's instructions supplied with the kit.

TABLE 1 - Kit #	550002663	550002664	550002665
Model	50/100/ 150/200	75	125/170
DESCRIPTION	PART # (QTY)	PART # (QTY)	PART # (QTY)
Pilot Orifice - Spark	PB00208 (1)		
Orifice	# 47 (4)	# 50 (2)	# 49 (4)
Label, "Nat to LP" Conversion Plate	240004822 (1)		
Liquid Sealing Compound	140010 (1)		
Spring Kit	1272030 (1)		
Instructions	240009725 (1)		

Tools Required

- Flat Head Screwdriver
- 1/4" Nut Driver
- 7/16" Open Ended Wrench
- 3/16" Allen Wrench
- 18" Manometer (or dial manometer)

Converting Boiler From Natural Gas To Propane (LP):

1. Follow instruction TO TURN OFF GAS TO APPLIANCE. Verify electrical power is OFF.
2. Remove front panel.
3. Remove burner access door.
4. Remove main gas burner tubes. See Figure 1.
5. Remove main burner orifices. See Figure 1.
6. Install LP gas main burner orifices. Discard excess LP orifices.
7. Use 7/16" wrench, disconnect pilot tube from pilot. See Figure 2.
8. Remove pilot orifice.
9. Install LP gas pilot orifice.
10. Apply liquid sealing compound (provided) to threads of pilot assembly fitting.
11. Reattach pilot tube to pilot and securely tighten. See Figure 2.
12. Replace main gas burner tubes.

Figure 1 - Burners Assembly

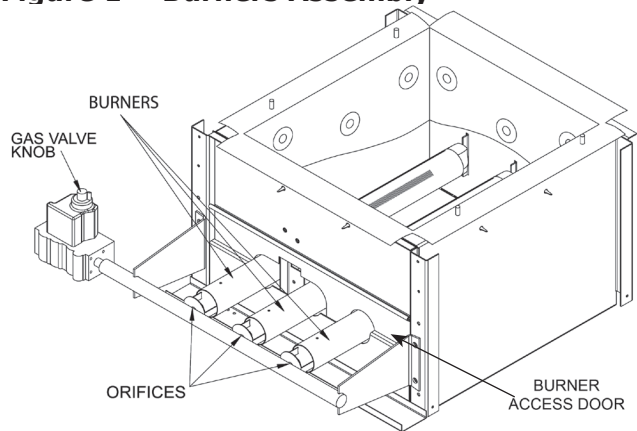
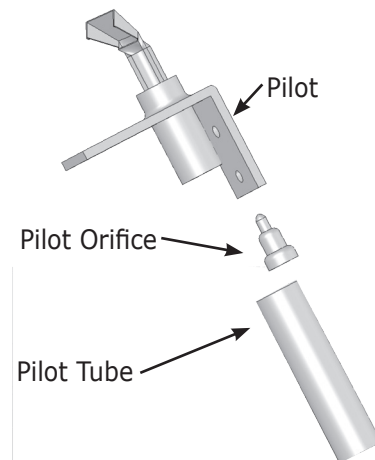



Figure 2 - Pilot Assembly



NATURAL GAS TO LP CONVERSION INSTRUCTIONS

13. Remove cover screw from gas valve pressure regulator. See Figure 3.
14. Remove adjustment screw by turning counterclockwise . See Figure 4.
15. Remove stainless steel natural gas spring.
16. Insert Red LP gas spring.
17. Install new adjustment screw. Assure screw top is flush with regulator top.
18. Turn pressure regulator adjustment screw clockwise  eleven (11) complete turns. (This is starting point for manifold pressure.)
19. Install manometer to pressure tap on outlet side of gas valve. See Figure 3.
NOTE: Gas inlet pressure should be between minimum of 11" w.c. and maximum of 14" w.c.
20. Turn electric and gas supply ON.

DANGER

Fire Hazard. Do not use matches, candles, open flames, or other methods providing ignition source. Failure to comply will result in death or serious injury.

21. Check for gas leaks around all gas connections using commercially available soap solution specifically made for leak detection.
22. While boiler is running adjust manifold pressure to 11" water column by turning pressure regulator adjustment screw. Check for CO₂ and CO levels to assure proper operation.
23. Turn electric and gas supply OFF.
24. Remove manometer. Replace pressure tap cover screw securely.
25. Install Black LP gas regulator adjustment cover screw with o-ring. See Figure 4.
26. Mount conversion label on gas valve (found in spring kit).
27. Turn electric and gas supply ON.
28. Cycle boiler to ensure proper operation and lighting.
29. Replace front panel.
NOTE: Complete following steps to provide proper identification for customer service or technical support issues.
30. Copy serial number from old rating plate to new one.
31. Mount new rating plate adjacent to old one.

Parts for steps 16, 17, 25, and 26 are located in Honeywell LP gas conversion kit HW#393691 (ECR # 1272030) for VR8204, and VR8304 gas valves.

Figure 3 - Gas Valve

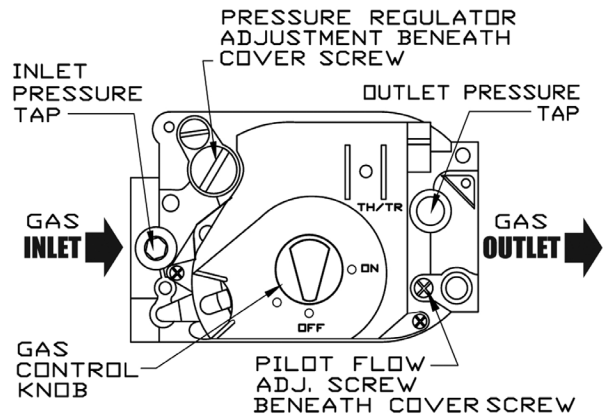

Figure 4 - Gas Valve Adjustment Screw Assembly

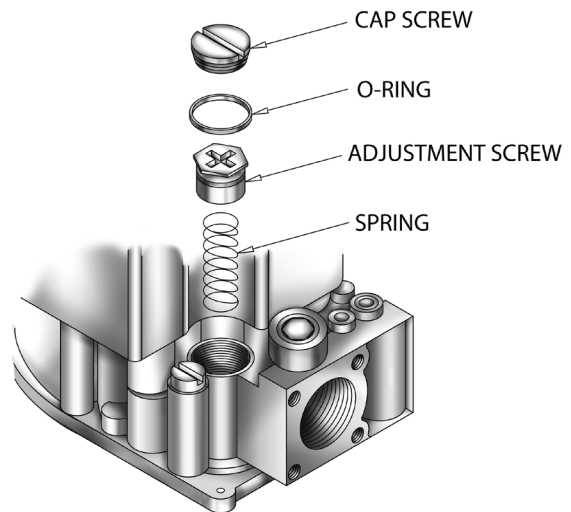

TABLE 1 - Main Burner Orifices	
Boiler Size	Orifice
50, 100, 150, 200	47
125, 170	49
75	50

TABLE 2 - Propane (LP) Orifices	
Manufacturer	Part Number
ECR	PB00208
Honeywell	390686-36