

WIRING DIAGRAM 150/200/299

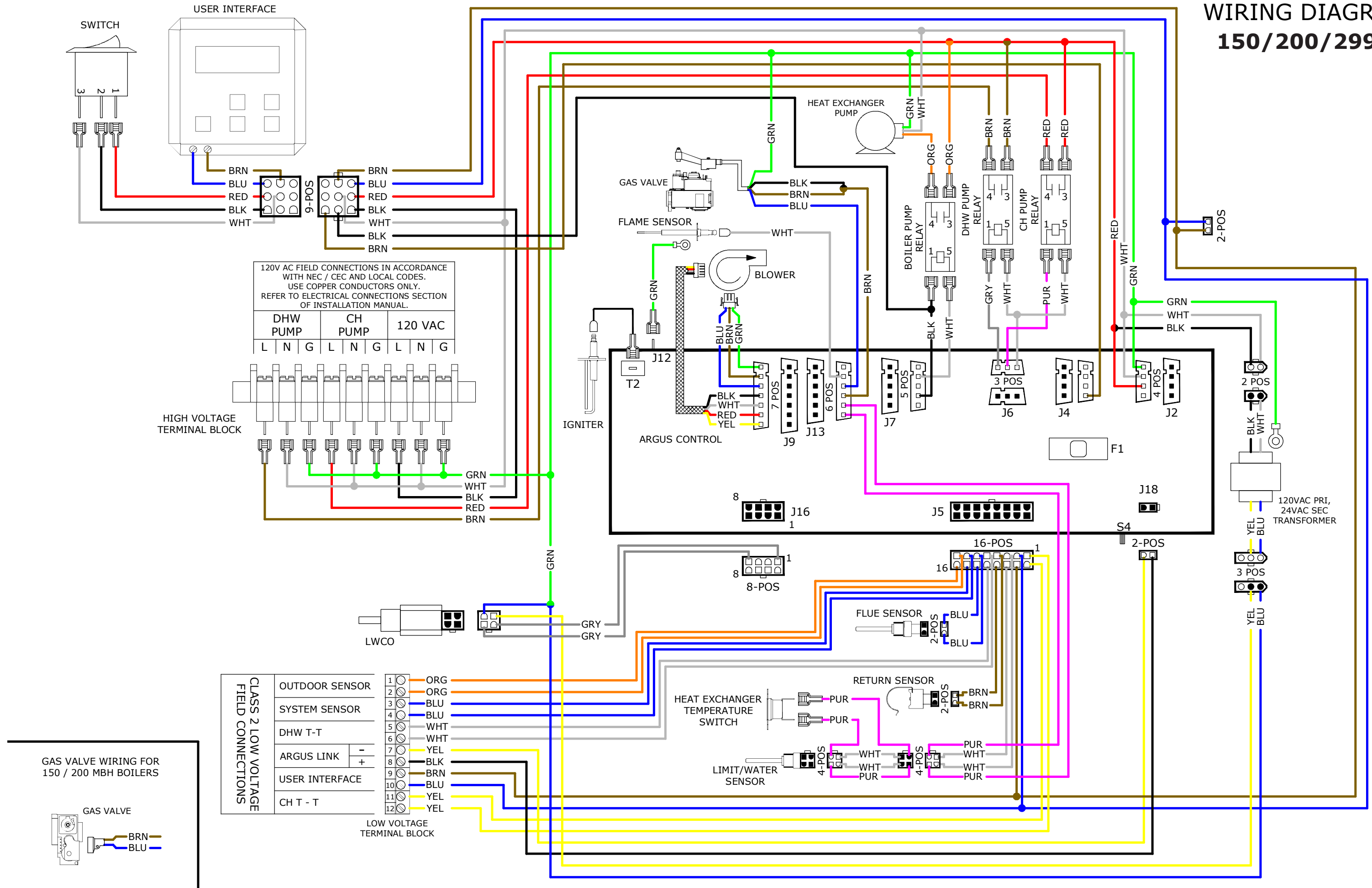

120V AC FIELD CONNECTIONS IN ACCORDANCE WITH NEC / CEC AND LOCAL CODES. USE COPPER CONDUCTORS ONLY. REFER TO ELECTRICAL CONNECTIONS SECTION OF INSTALLATION MANUAL.

DHW PUMP			CH PUMP			120 VAC		
L	N	G	L	N	G	L	N	G
BRN	BLU	RED	BRN	BLU	RED	BLK	WHT	BRN

HIGH VOLTAGE TERMINAL BLOCK

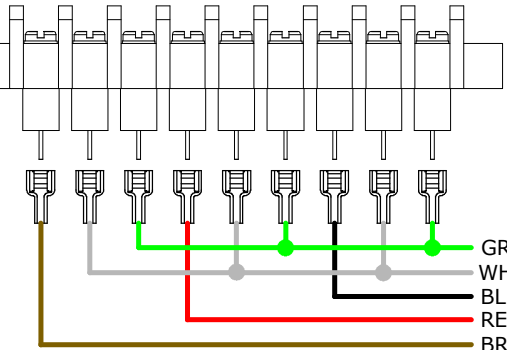

CLASS 2 LOW VOLTAGE FIELD CONNECTIONS

OUTDOOR SENSOR	1	ORG
	2	ORG
SYSTEM SENSOR	3	BLU
	4	BLU
DHW T-T	5	WHT
	6	WHT
ARGUS LINK	7	YEL
	8	BLK
USER INTERFACE	9	BRN
	10	BLU
CH T - T	11	YEL
	12	YEL

LOW VOLTAGE TERMINAL BLOCK

GAS VALVE WIRING FOR 150 / 200 MBH BOILERS

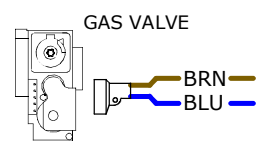

LADDER DIAGRAM 150 / 200 / 299

