

WIRING DIAGRAM 150/200/299

USER INTERFACE

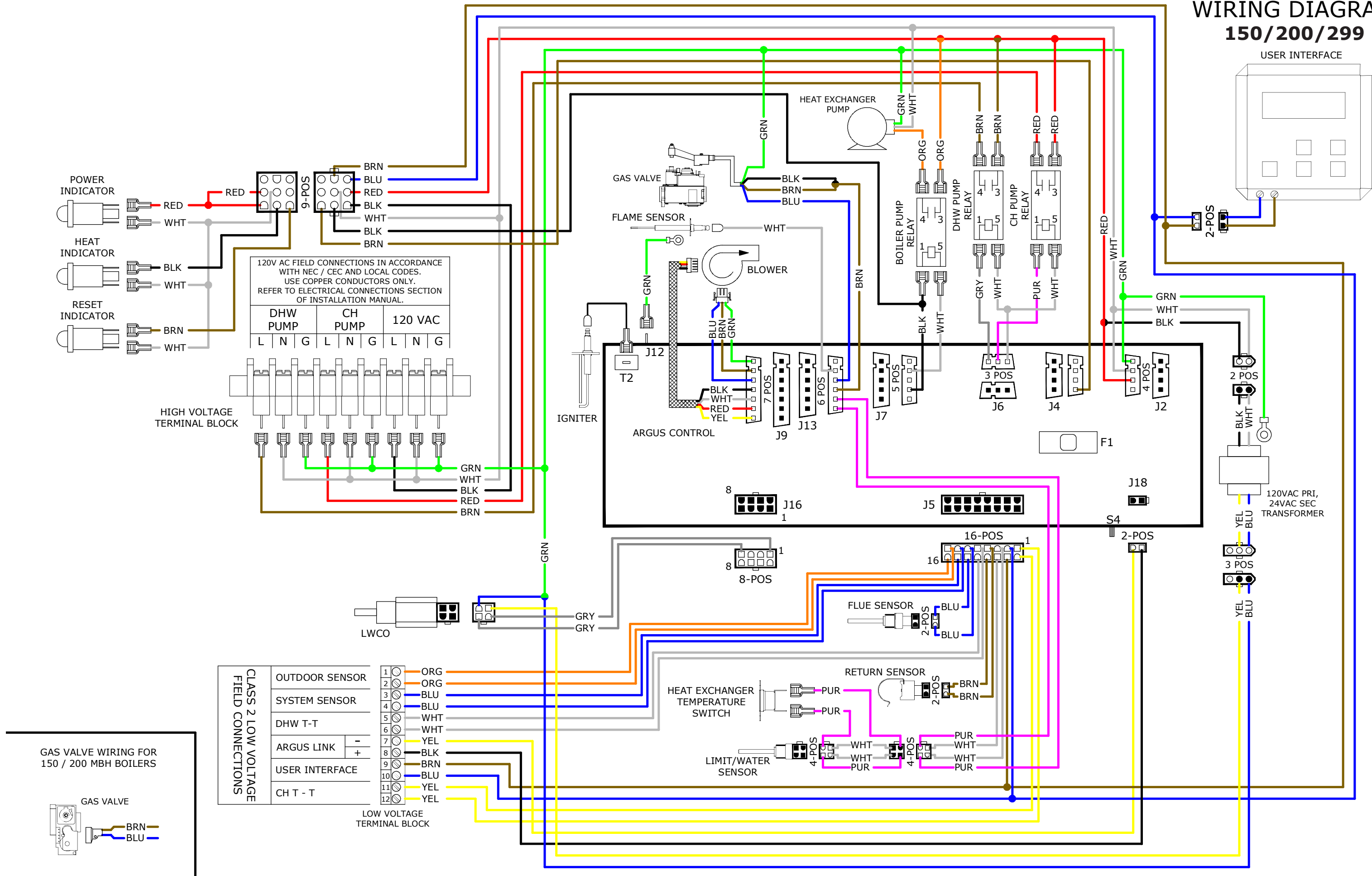

120V AC FIELD CONNECTIONS IN ACCORDANCE WITH NEC / CEC AND LOCAL CODES. USE COPPER CONDUCTORS ONLY. REFER TO ELECTRICAL CONNECTIONS SECTION OF INSTALLATION MANUAL.

DHW PUMP			CH PUMP			120 VAC		
L	N	G	L	N	G	L	N	G
1	2	3	4	5	6	7	8	9

HIGH VOLTAGE TERMINAL BLOCK

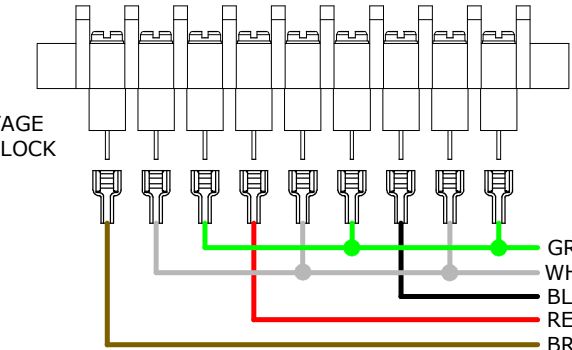

CLASS 2 LOW VOLTAGE FIELD CONNECTIONS

1	OUTDOOR SENSOR	ORG
2	OUTDOOR SENSOR	ORG
3	SYSTEM SENSOR	BLU
4	SYSTEM SENSOR	BLU
5	DHW T-T	WHT
6	DHW T-T	WHT
7	ARGUS LINK	YEL
8	ARGUS LINK	BLK
9	USER INTERFACE	BRN
10	USER INTERFACE	BLU
11	CH T - T	YEL
12	CH T - T	YEL

LOW VOLTAGE TERMINAL BLOCK

GAS VALVE WIRING FOR 150 / 200 MBH BOILERS

