

CM / CW / WM Series

Installation, Operation & Maintenance Manual

Replacement Water Source
Heat Pump Consoles

CM

Replacement for:
Freidrich and Climate Master
"801" Series Water Source

WM

Replacement for:
McQuay, Singer, or Climate
Control WM Series Water
Source

CW

New Construction
Replacement for:
Freidrich and Climate Master
CW and "800" Series Water
Source



TABLE OF CONTENTS

Receiving Information	3
Important Safety Information.....	4
Dimensional/Physical Data	5
Product Description.....	9
General Product Information	11
Installation Preparation	12
Installation	13
Final Inspection And Start-Up.....	14
Sequence Of Operation.....	17
Maintenance	19
Performance Data CM / CW / WM **	21
Electrical Specifications	22
Warranty	26



Information and specifications outlined in this manual in effect at the time of printing of this manual. ECR International reserves the right to discontinue, change specifications or system design at any time without notice and without incurring any obligation, whatsoever.

RECEIVING INFORMATION

**Shipping damage MUST be reported to the carrier IMMEDIATELY.
Examine exterior.**

Remove cover and examine compressor and piping for signs of damage.

Inspection

Check shipment against bill of lading.

Verify equipment received as ordered.

Verify unit:

- Unit size and type correct per submittal sheet and job requirements?
- Voltage correct?
- Correct Chassis has been received (with options as ordered)?
- Electric heat correct capacity, if used?
- Hydronic coil included, if required? Piping located as required?

Inspect each component for damage. Concealed damage **must** be reported to carrier within 15 days of receipt of shipment.

Carrier must make proper notation on delivery receipt of all damage identified and complete carrier inspection report.

Purchaser must notify Manufacturer's Service department of all damage and is responsible for filing any necessary claims with carrier.

General Information

Installation shall be completed by qualified agency. Retain this manual and warranty for future reference.

Installer review this manual to verify unit has been installed correctly. Run unit for one complete cycle to verify proper function.

To obtain technical service or warranty assistance during or after installation, contact your local representative.

Visit our web site www.retroaire.com for local representative listing.

When calling for assistance, please have following information ready:

Model Number _____

Serial Number _____

Date of installation _____

Customer Service : (800) 228-9364

IMPORTANT SAFETY INFORMATION

All wiring should be in accordance the National Electric Code (NEC) and or in absence of such code requirements of the authority having jurisdiction.



**Become Familiar With Symbols
Identifying Potential Hazards.**

DANGER

Indicates a hazardous situation which, if not avoided, **WILL** result in death or serious injury.

WARNING

Indicates a hazardous situation which, if not avoided, could result in death or serious injury.

CAUTION

Indicates a hazardous situation which, if not avoided, could result in minor or moderate injury.

NOTICE

Indicates information which should be followed to ensure proper installation and operation.

WARNING

Fire, and electrical shock hazard. Improper installation could result in death or serious injury. Read this manual and understand all requirements before beginning installation.

WARNING

Tampering is dangerous and could result in death or serious injury. Do not modify or change this unit.

CAUTION

Chassis is heavy to avoid injury use assistance when lifting. Failure to follow these instructions could result in minor or moderate injury.

Safety Information

- Use this unit for its for intended use only.
- Installation by qualified personnel.
- Turn off electrical supply before servicing unit.
- Inspect all parts for damage prior to installation and start-up.
- Do not use unit if it has damaged wiring, is **not working** properly, or has been damaged or dropped.
- Connect to properly grounded electrical supply with proper voltage as stated on rating plate.
- Have proper over-current protection (i.e. time- delay fuse/HACR Breaker) as listed on Rating Plate.
- Shall connect unit to properly grounded electrical supply.
- Tampering voids all warranties.

Figure 1 - CM Chassis

TOP

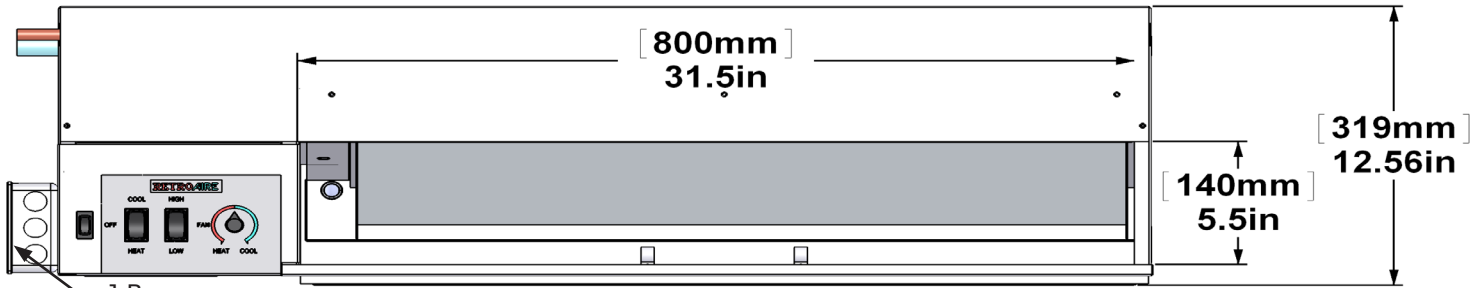

FRONT

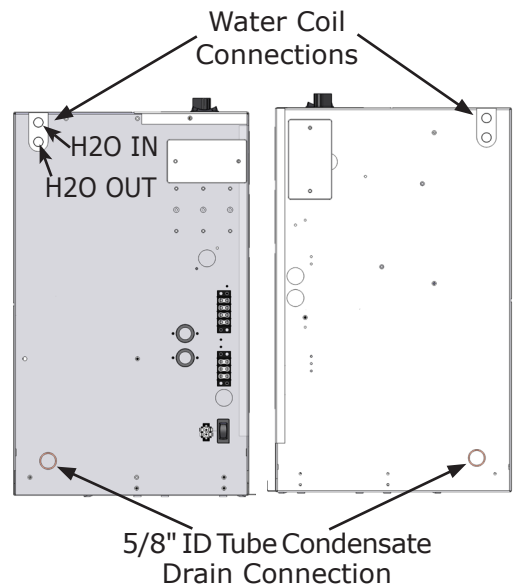
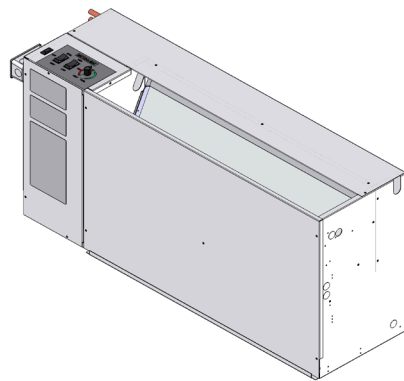
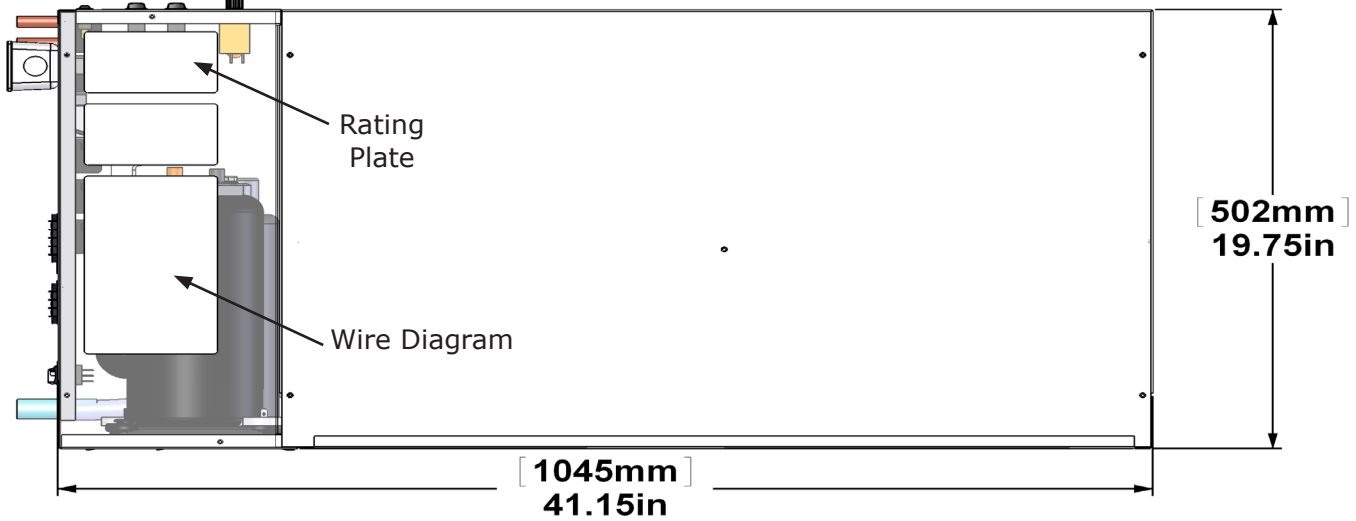
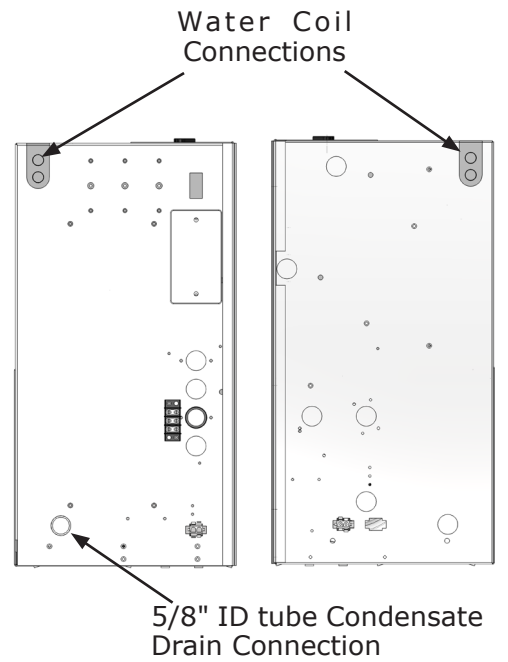
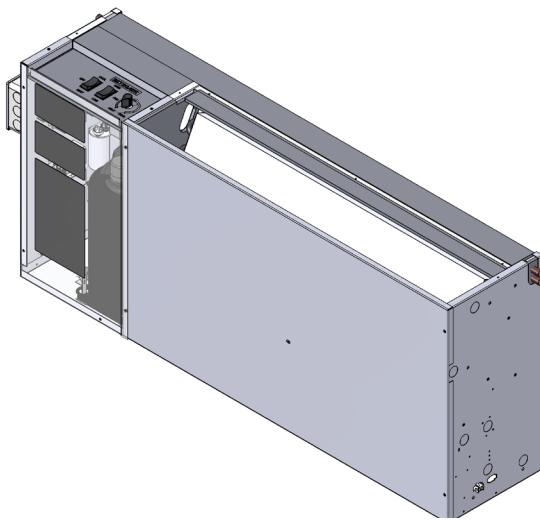
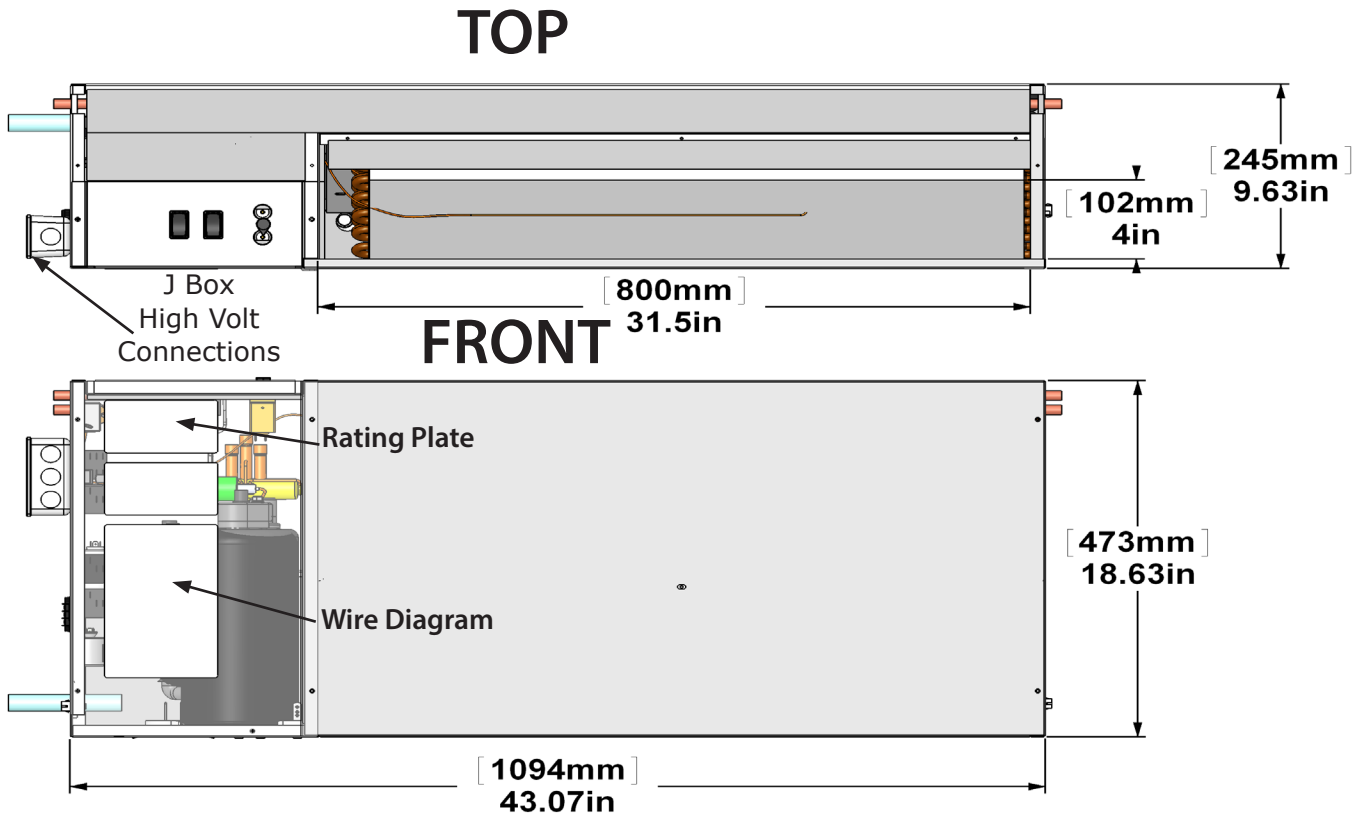

Figure 2 - CW Chassis



DIMENSIONAL/PHYSICAL DATA

Figure 3 - WM Chassis

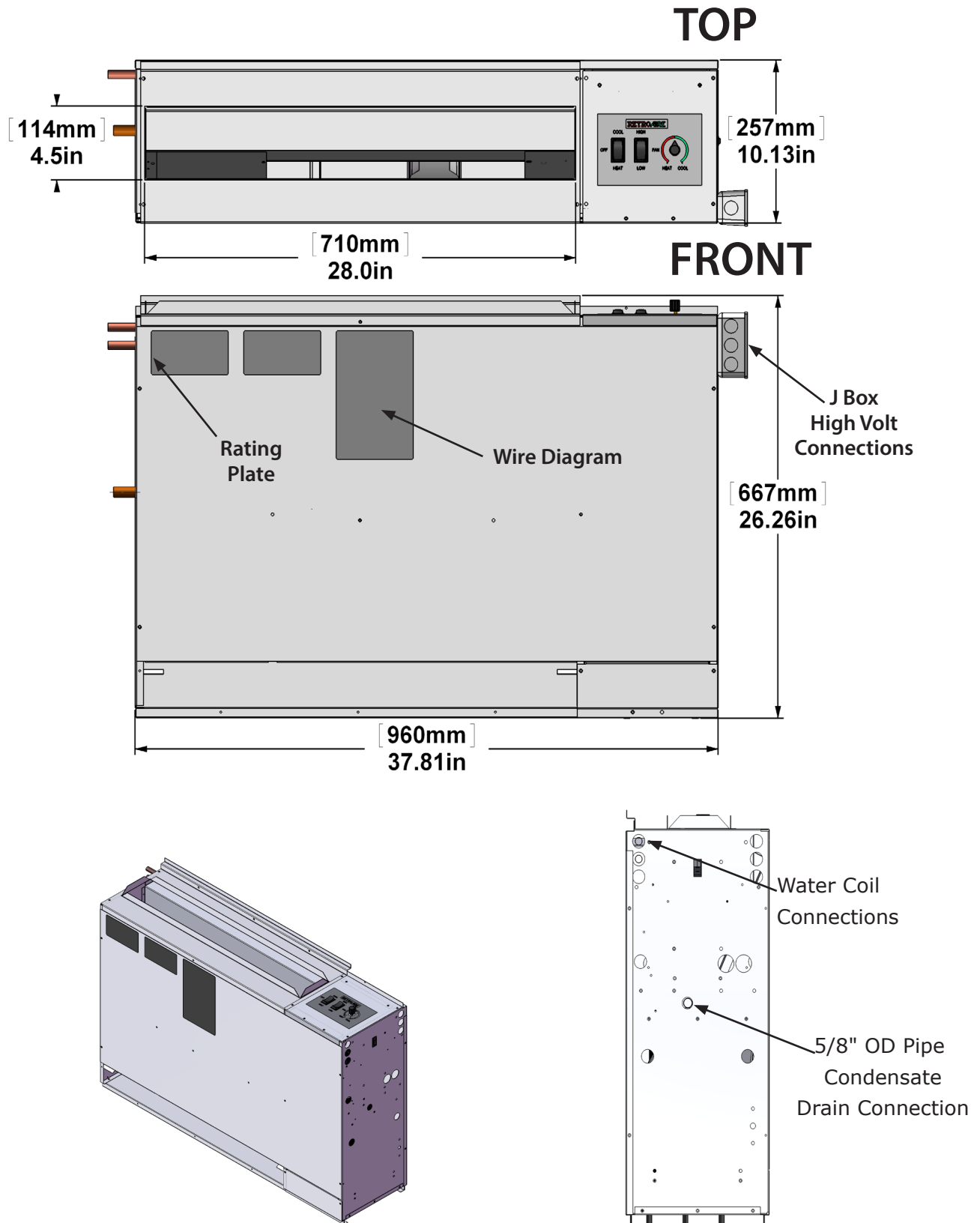
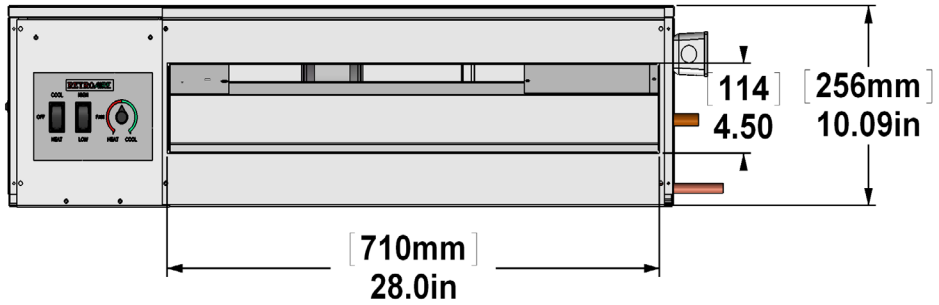
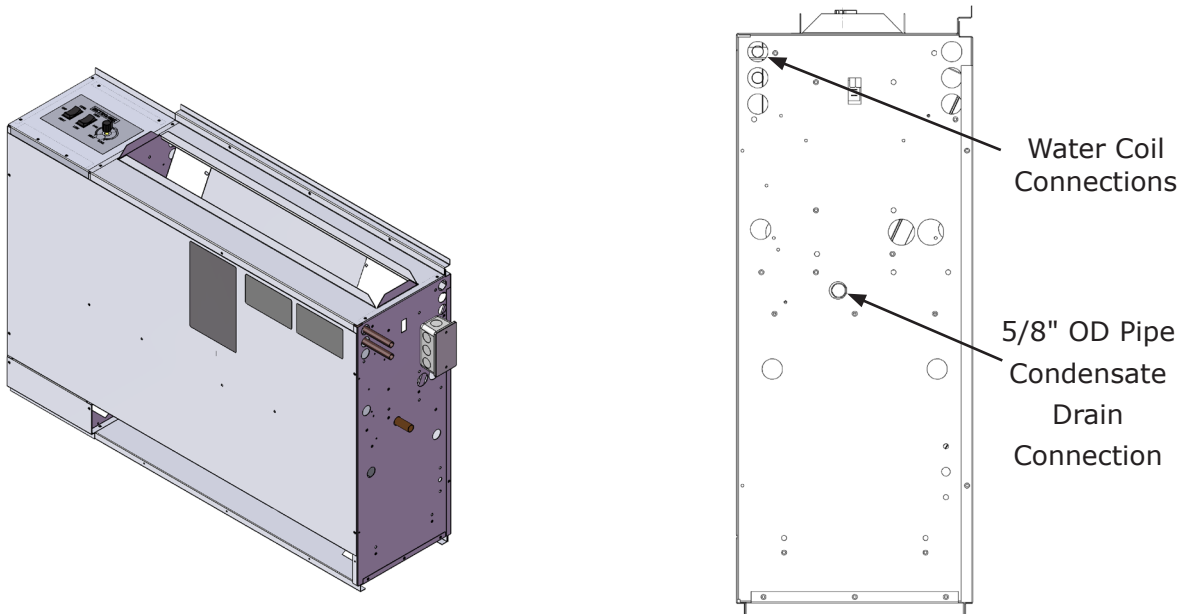
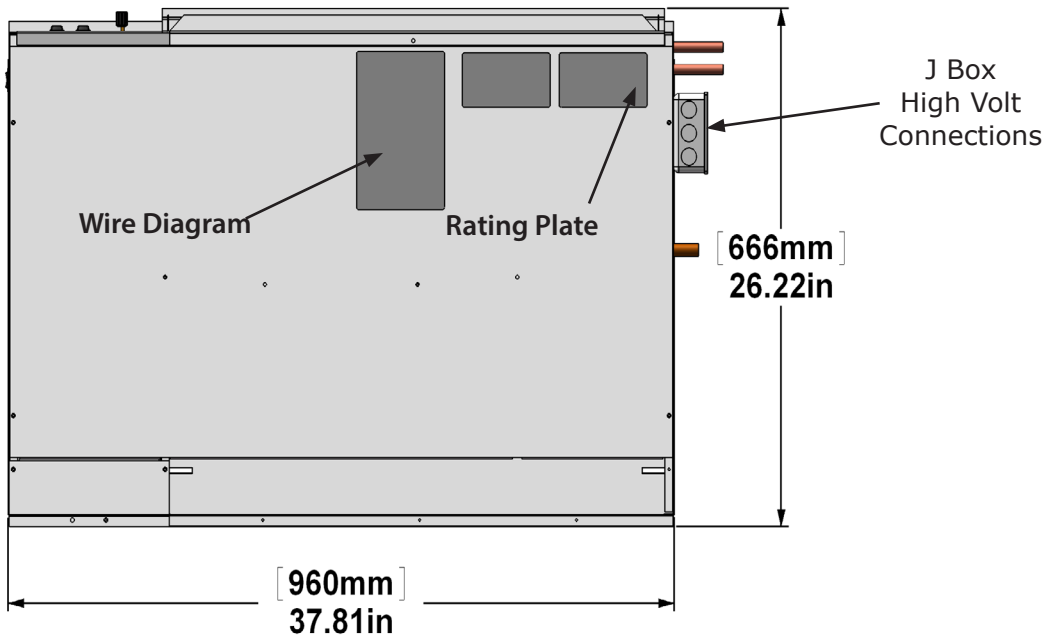

Figure 4 - WM Right Chassis And Installation Kit Contents

TOP



FRONT



PRODUCT DESCRIPTION

Figure 5 - CM Chassis (LEFT)

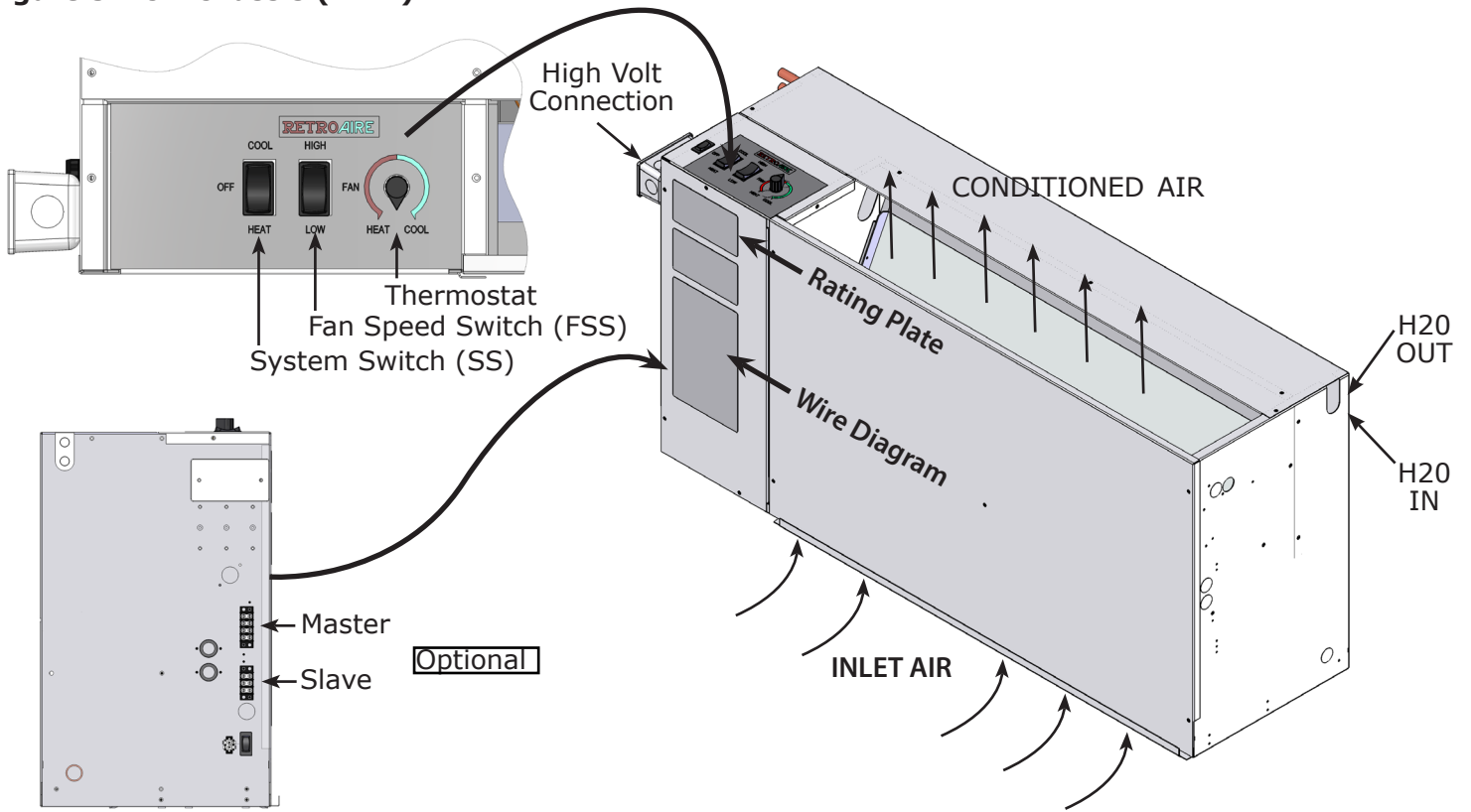
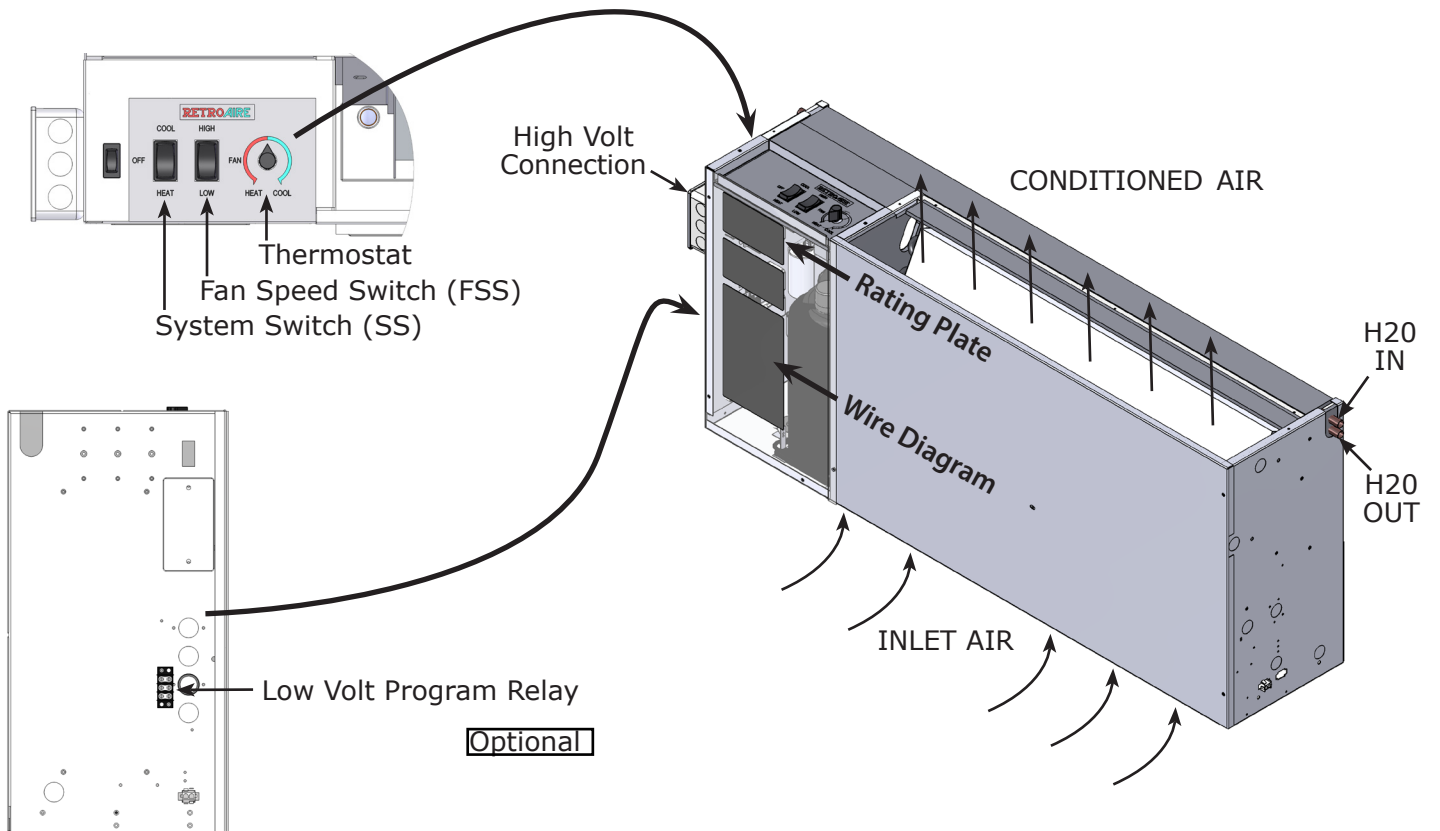

Figure 6 - CW Chassis



PRODUCT DESCRIPTION

Figure 7 - WM Chassis (Left)

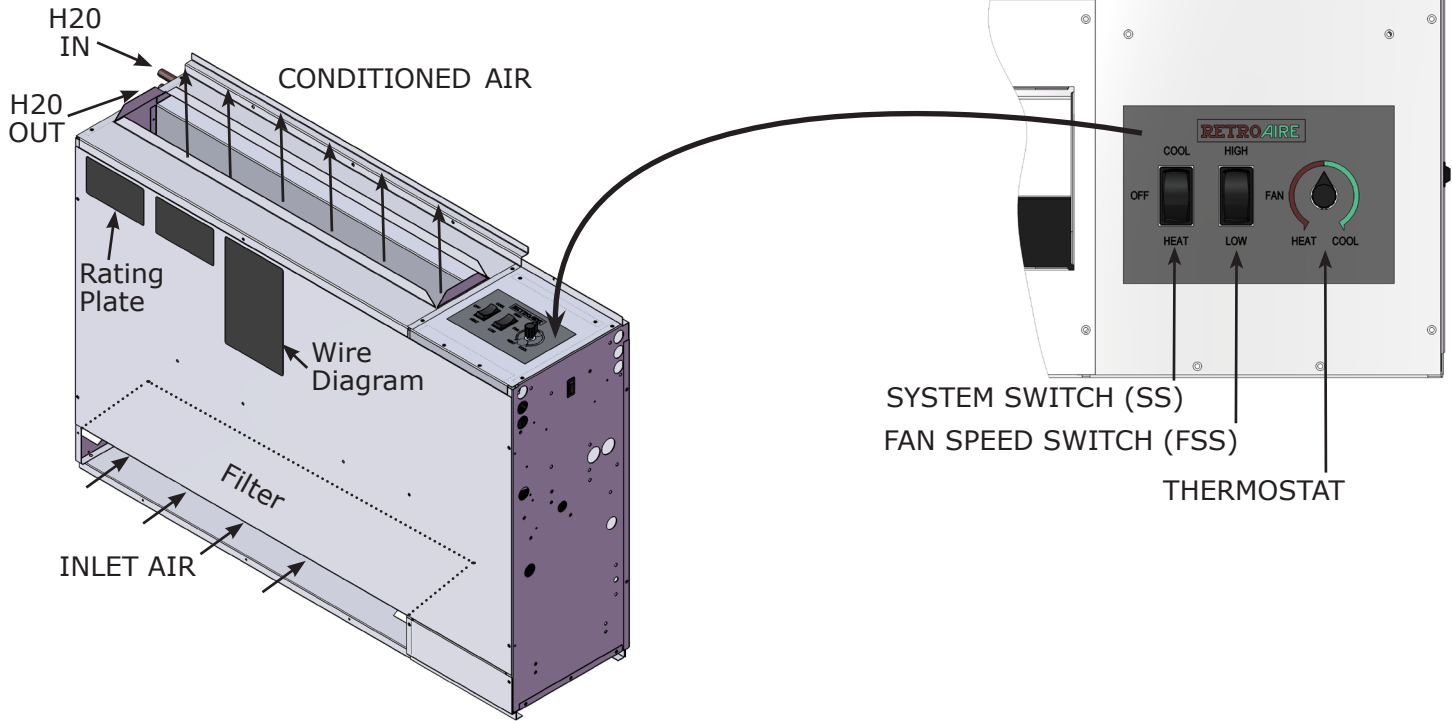
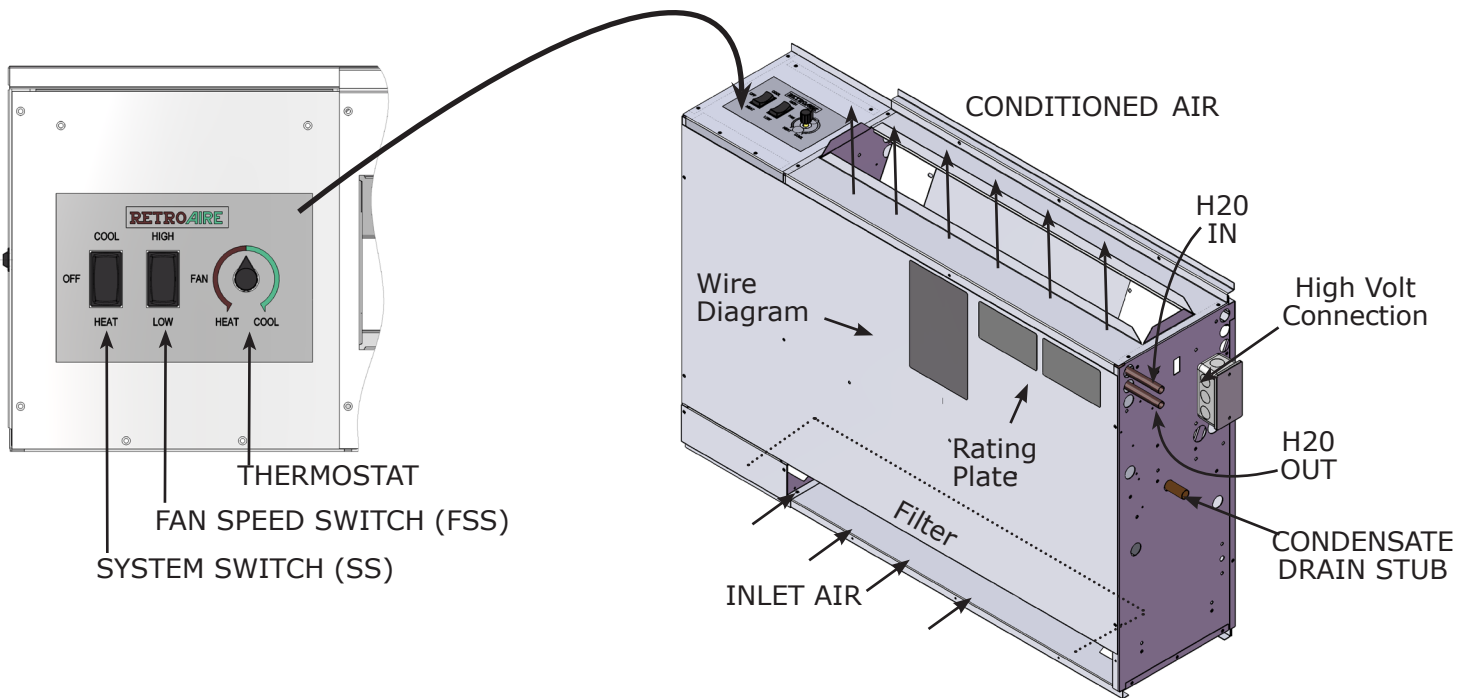

Figure 8 - WM Chassis (Right)



Product Description

- Water Source Console units are available as heat pump systems. Model CW is available as straight cool.
- R-410A refrigerant.
- Provided high-efficiency rotary compressor.
- Provided enhanced high-efficiency heat exchanger.
- Two fan speeds.
- Energy Efficiency Rating(EER) in excess of 12.2
- Coefficient of performance(COP) in excess of 4.3 for (heat pump models only)

Standard Controls And Components:

• Construction

- 20-gauge galvanized steel Water Source Console Units construction of chassis.
- Powder-coated evaporator drain pan.
- Foam strip seal for supply air duct.

• Air Systems

- Indoor fan motor is thermally-protected PSC type.
- Air-stream surfaces are insulated with 1/8" fiberglass or 1/4" (3.2 mm) Volara™.
- Indoor fan is forward curved type, directly mounted to motor shaft.

• Controls

- Unit-mounted operating controls include thermostat, fan speed control and heat/cool switch.
- Remote mount controls include fan speed control.
- High pressure switch.
- Low Temperature/Low water flow cut out switch compressor lock out relay
- 4-Way reversing valve with solenoid activated by line voltage. Solenoid is energized for cooling mode. (Heat pump models only).

• Field-Installed Accessories:

- Remote thermostat
- Hydronic heat valves
- Cabinets

Optional Wall-Mounted Thermostats:

EMI thermostats.

- Single stage, cool/heat, thermostat that can be used in all RetroAire cooling, heating or heat pump applications.
- Thermostat has adjustable setpoint range of between 45°F (7°C) and 90°F (32°C).
- Heat pump option is a 2 stage heat/cool thermostat which allows for emergency heat.

Alternate Manufacturer Thermostat

- Choose a single stage heat/cool, 24v thermostat.
- Straight cooling with electric heat or hydronic heat. Select a thermostat compatible with cooling/electric heat system. Thermostat should have "R", "Y", "W" and "G" terminals.
- Heat pump, select a thermostat compatible with cooling/single-stage heat/heat pump system. Thermostat should have "R", "Y", "O" and "G" terminals. RetroAire units are single stage heating only.

INSTALLATION PREPARATION

DANGER

Electrical shock hazard. Before opening existing unit open power supply disconnect switch. Secure in open position during installation. Attach a sign stating, "DO NOT TURN ON."

Unplug existing unit at wall outlet. DO NOT plug in new unit until installation is complete and start-up checklist has been completed. Failure to do so will result in death or severe personal injury.

WARNING

Moving parts can cause personal injury. Avoid contact with moving parts when testing or servicing the unit.

Remove Old Chassis

- Disconnect power or unplug cord before proceeding.
- Remove cabinet from old chassis.
- Disconnect water supply to coil.
- Disconnect condensate drain piping
- Remove any fasteners holding old chassis to sub base or wall and remove chassis.

NOTICE

Dispose of old chassis following existing state and federal regulations.

Chassis and Grills

- Secure existing front panels with screws that prevent contact with all parts.
- Minor dimensions of openings must not exceed ½ inch (12.5mm).
- Dimensions of indoor air discharge grill must not be less than 26" x 4". Grill must separate top surface of chassis from top surface of discharge grill by minimum of 1 in (25.4mm).

Electrical Supply

- Each unit must have separate branch circuit protected by a fuse or breaker. Refer to rating plate for proper wire and breaker or fuse size.
- Use of extension cords is prohibited.
- DO NOT connect RetroAire unit to circuit with incorrectly-sized over current protection device.
- All cord-connected 265 volt units must be plugged into receptacles within unit subbase or chassis.

Electrical Power Connection

- Verify RetroAire unit rating plate for circuit ampacity and required breaker or fuse size.
- Verify existing breaker or fuse is correct size.
- Replace breaker or fuse if incorrectly-sized.
- Breakers must be type HACR only.
- Cord-connected units — verify wall outlet is correct rating. Outlet's blade configuration must match cord supplied with RetroAire unit.
- Hard-wired units — verify power wiring is correctly sized. Inspect existing wiring for any deficiencies, such as cuts or frayed wires. Replace such wiring if found.
- Refer wire diagrams for wire connections.

Installation

1. See instructions for specific RetroAire unit.
2. **DO NOT** connect power to unit or plug in cord until instructions in this manual have been completed.
3. Place new chassis in same place where old chassis stood. Secure to subbase or wall as older unit was secured.
4. Check hose for cracks and/or brittleness, replace with new hoses if any damage is found. Pipe new chassis with same hoses.
5. Hard piping, there should be union between unit and hand shut off valve for service or removal of unit. Connect condensate tube, and route to adequate drain.
6. Plug line cord into receptacle.
 - If hard wired; connect power wiring to unit wires in J-box. See wiring diagram on unit. Follow instructions on page 12 to verify existing wiring and over-current protection.
 - Remove line cord wires from Water Source Console Units power entrance terminals. Route power supply wiring through strain-relief bushing and connect leads to power entrance terminals.
 - Secure strain-relief clamp. If wiring is through conduit, insert conduit through control box knockout and secure in place.
 - **DO NOT** turn on power until completing instructions in "Final Inspection and Startup" on page 14.
7. Open water valves. Bleed air from water lines with air vent (if used) or by uncoupling return water line allow any air to escape.
 - If water appears dirty entire water system should be flushed with proper cleaners to obtain PH value of 7 or 8.
 - Take care if any sort of glycol(antifreeze) is being used when cleaning system. Be careful not to let fluid get on any carpeting etc.
8. **DO NOT PLUG LINE CORD IN**, if in used condition.
9. Follow instructions in "Final Inspection and Startup" on page 14.

Before Operating Unit

- Verify electrical supply matches electrical requirements of the unit, and unit is properly grounded.
- Examine control box. Ensure all wire connections are secure.
- Verify chassis is properly fitted to cabinet and securely mounted to sub base or floor.
- Make sure chassis is level.
- Pour water into drain pan and verify it flows from drain pan to condensate drain
- Verify indoor blower wheels are secured to motor shaft, and rotate freely.
- Ensure all sheet metal panels are in place and secure.
- Attach front panel to existing cabinet enclosure.
- Verify nothing interferes with room discharge air or return air of units.
 - Check for curtains or drapes that obstruct air flow.
 - See Figures 9 and 10.
 - Check for plush carpeting that can obstruct return air.
 - Items like these can cause serious damage to chassis.
- Any obstruction of supply air, including use of deflector baffles, may cause condensate to form on louver or cabinet . See Figure 9).
- To ensure optimum performance of your Water Source Console Unit, avoid restricting air flow. Position of curtains or drapes over supply air grille may cause air to recirculate without cooling the room. Unit will short cycle and may cause premature compressor failure. See Figure 10.

Figure 9 - Proper Air Flow Diagram



Figure 10 - Restricted Air Flow Diagram



Start Up

Initiate proper unit start up.

1. Adjust all hand water valves to full open position. Turn power on to the units. If when taking old unit out you marked the position of hand water valve handle put it back to that position rather than full open.
2. Operate each unit in cooling cycle first.
 - Set thermostat temperature lower than room temperature and depress "Cool" button.
 - Entering water temperature (EWT) should be at least 60°F (16°C). for start up.
 - Unit will start discharging cool air.
 - After unit has been running about 5 minutes check temperature of EWT and leaving water temperature (LWT). difference should show higher LWT by about 10-12°F (6-7°C). If you find you have this difference you also have correct water flow. If the difference is less then 10-12°F (6-7°C) you have too much water flowing through the unit. If difference is higher you don't have enough water flowing through the unit. Adjust the hand water valve to get the temperature difference needed.
3. Check unit heating operation. Turn thermostat to slightly above room temperature. Depress "Heat" button. Compressor and fan operate. After about 5 minutes of operation check water temperature of EWT & LWT. For correct water flow adjust hand valves until LWT is 6°F (3°C) less than EWT.
4. Unit Mount ACO (Automatic change-over) with Fan Cycle Switch (Optional). This option allows evaporator fan cycle to run continuously. Place switch in cycling position evaporator fan only runs when unit is calling for heat or cooling. When switch is placed in "constant" position, evaporator fan runs continuously unless unit is physically turned off.

Three factors determine operating limits of RetroAire heat pump units:

1. Return air temperature
2. Water temperature
3. Ambient temperature

Whenever any one of these factors is at minimum or maximum level, other two factors must be at normal levels to ensure proper unit operation.

Operating Limits

WMH/CM/CW Operating Limits		
Air Limits	Cooling°F (°C)	Heating°F (°C)
Min. Ambient Air	50 (10)	50 (10)
Rated Ambient Air	80.7 (27)	68 (20)
Max. Ambient Air	100 (38)	85 (30)
Min.*EAT DB/WB °F	67/57 (20/14)	N/A
Rated *EAT DB/WB	80.7/66.3 (27/19.1)	68 (20)
Max. EAT DB/WB	100/83 (38/29)	80 (27)
Water Limits	Cooling°F (°C)	Heating°F (°C)
Min. EWT	60 (16)	60 (16)
Max. EWT	95 (35)	90 (33)

(*EAT' and Ambient Temperature surrounding the unit are same value)

STARTING CONDITIONS

Unit starts and operates with entering air temperature(EAT) of 50°F(10°C) and entering water temperature(EWT) of 60°F(16°C) with both air and water at flow rates used in AHRI Standard 320/86 rating test, for initial start up in winter. This is start up only, not long running time.

If unit fails to operate:

- A. Check voltage and current is in accordance with electrical specifications on unit rating plate.
- B. Look for wiring errors. Check for loose terminals or wire nuts where wire connections have been made on both line and low-voltage terminal boards.
- C. Check for water leaks around hose swivel joints. If hard piped check all joints. After unit is running check for leaks around condensate drain hose and connection.
- D. Verify High Pressure Switch (HPS) did not trip. Cycle system switch off to reset lockout relay.
- E. Determine if fan operates during heating and cooling modes.

If these checks fail to reveal a problem and unit will not operate, contact a service technician for proper diagnosis.

Unit Mounted Thermostat - See Figure 11.

1. Place Water Source Console Units in "COOL", "HEAT", or "OFF" position. Test operation in all positions.
2. Place fan in either **LOW** or **HIGH** speed using fan speed switch. Test operation in both positions for heating and cooling.
3. Test operation of optional Fan Cycle switch. Toggle switch located on side of control box. With switch set ON (continuous fan operation) or AUTO (cycling with thermostat) for both heating and cooling. Set switch in desired position.
4. Rotate thermostat knob counter clockwise ↶ to increase setpoint temperature, or clockwise ↷ to decrease. Turn unit-mounted thermostat knob counter clockwise ↶ until it stops produces warmest room temperature, while turning it clockwise ↷ until it stops produces coolest. Adjust setting for personal comfort.

Remote Mounted Thermostat

1. Place thermostat in either "COOL", "HEAT", or "OFF" position. Test operation in all positions.
2. If thermostat is fitted with fan switch, set as desired places fan in either "ON", "OFF", or "AUTO". Test operation in all positions.
3. Check thermostat calibration for both heating and cooling operation.

Straight Cooling Water Source Console Units

Cooling Cycle

NOTICE

When unit is first powered up, high humidity conditions may cause condensation to form on the discharge grill. Keep doors and windows closed to reduce humidity allowing condensation to evaporate.

Room temperature must be above 65°F (18°C) for compressor to operate in cooling mode on Water Source Console Units with unit-mounted controllers.

1. Place thermostat or system switch in **COOL** position.
2. Adjust thermostat to cooler temperature until indoor fan starts running. Compressor should turn on and cold air begin to flow from the unit. Let unit continue operating to cool the room and remove humidity.
3. After unit starts running and space gets cooler, adjust thermostat to warmer temperature until compressor cycles off.
4. If colder room temperature is desired, adjust thermostat to cooler temperature setting, turning compressor and fan back on.
5. If warmer room temperature is desired, adjust thermostat to warmer temperature setting, compressor stops.
6. Place thermostat or system switch in **OFF** position. All operation should stop.

Heating Cycle – Electric Option

Room temperature must be below 85°F (29.4°C) to energize the heater on Water Source Console Units with unit-mounted controllers.

1. Place thermostat or system switch in **HEAT** position.
2. Adjust thermostat for warmer temperature until indoor fan starts running and electric heater coil starts emitting heat.
3. After unit starts running and space gets warmer, adjust thermostat to cooler temperature until electric heater turns off.
4. If warmer room temperature is desired, adjust thermostat to warmer temperature setting, which will turn electric heater back on.

Figure 11 - Typical Unit Mount Control

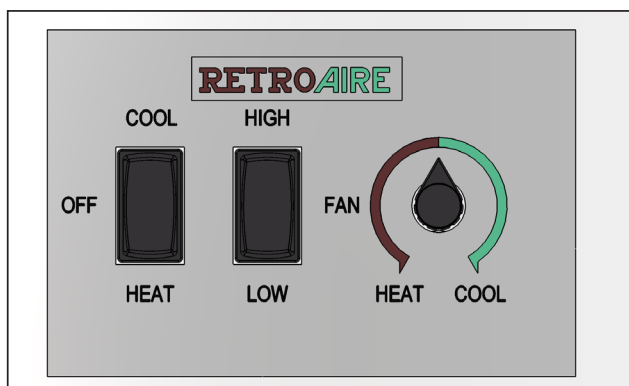

Boiler-less Control Operation-Optional

- Heat pump units with optional Boiler-less control and electric heat, heat pump and electric heat do not operate simultaneously.
- Boiler-less control monitors incoming water temperature to heat exchanger and when it drops below approximately 50°F control will change from heat pump operation to electric heat.

NOTICE

DO NOT rotate thermostat knob back and forth from heating to cooling. This causes compressor to cycle on and off rapidly and will cause damage to the compressor. Allow compressor to remain off for at least three minutes prior to restarting the unit.

SEQUENCE OF OPERATION

5. If cooler room temperature is desired, adjust thermostat to cooler temperature setting until electric heater turns off. Fan will stop.
6. Place the thermostat or system switch to OFF position. All operation should stop.

Heating Cycle — Hydronic Option

Verify the motorized valve is rated for correct voltage.

- Most RetroAire units with unit mount controls will power hydronic valve that is same voltage as unit (ex: unit rated 208/230V will power a 208/230V).
- Check the wiring diagram (located on the unit) and voltage application for the specific unit.
- Other valve configurations and voltage options are available. Consult Technical Service if unit voltage does not match your valve application.

Room temperature must be below 85°F (29°C) for hydronic heater to operate.

1. Place thermostat or system switch in HEAT position.
2. Adjust thermostat to warmer temperature. Following occurs
 - Motorized valve should open and allow hot water to run through coil.
 - Indoor fan will run, blowing air through hydronic coil.
 - Signal to water valve continues until room temperature rises above setpoint by 3°F (2°C).
3. After unit starts running and area warms, adjust thermostat to cooler temperature, hydronic valve closes and indoor fan switches off.
4. If warmer room temperature is desired, adjust thermostat to warmer temperature setting, which opens hydronic valve and turns on the indoor fan.
5. If cooler room temperature is desired, adjust thermostat to cooler temperature setting. Hydronic valve will close and fan stops.
6. Place thermostat or system switch to OFF position. All operation should stop.

Heat Pump Water Source Console Units

Unit is equipped with a reversing valve that is energized for cooling and de-energized in heating mode.

Cooling Cycle — Heat Pump Units

Room temperature must be above 65°F (29°C) for compressor to operate in cooling mode on Water Source Console Units with unit-mounted controllers.

1. Place thermostat or system switch to COOL.
2. Adjust thermostat to cooler temperature until indoor fan starts running. Compressor will turn on and cold air begins to flow from the unit. Allow unit to continue operating cooling the room and remove humidity.
3. After unit starts running and space gets cooler, adjust thermostat to warmer temperature until compressor cycles off.
4. If colder room temperature is desired, adjust thermostat to cooler temperature setting, turning compressor and fan back on.
5. If warmer room temperature setting is desired, adjust thermostat to warmer temperature. Cooling mode ceases and compressor and fan stop.
6. Place thermostat or system switch to OFF. All operation should stop.

Heating Operation — Heat Pump Units — Entering Water Temperature Above 60°F (16°C)

Room temperature must be below 85°F (29°C) for the compressor to operate in heating mode on Water Source Console Units with unit-mounted controllers.

1. Place thermostat or system switch to HEAT position.
2. Adjust thermostat to warmer temperature setting until compressor and fan start running. Warm air will begin to flow from unit.
3. After unit starts running and space warms, adjust thermostat to cooler temperature until fan and compressor turn off.
4. For warmer room temperature, adjust thermostat to warmer temperature setting turning fan, and compressor back on.
5. If cooler room temperature is desired, adjust thermostat to cooler temperature setting. Heating mode ceases and compressor and fan will stop.
6. Place thermostat or system switch in OFF position. All operation should stop.

Auxiliary Heating Operation – Electric Option

Room temperature must be below 85°F(29°C) to energize heater on Water Source Console Units with unit-mounted controllers.

1. Place thermostat or system switch to HEAT position.
2. Adjust thermostat to warmer temperature until fan starts running and electric coil starts emitting heat.
3. After unit starts running and space warms, adjust thermostat to cooler temperature until electric heater and fan turn off.
4. If warmer room temperature is desired, adjust thermostat to warmer temperature setting, which turns electric heater and fan back on.
5. If cooler room temperature is desired, adjust thermostat to cooler temperature setting until electric heater and fan turn off.
6. Place thermostat or system switch to OFF position.
All operation should stop.

Auxiliary Heating Operation— Hydronic Option

Room temperature must be below 85°F (29°C) for hydronic heater to operate on Water Source Console Units with unit-mounted controllers. Hydronic valve is 24Vac normally open valve. Should power be lost to the unit, valve defaults to open position.

1. Place thermostat or system switch to HEAT position.
2. Adjust thermostat to warmer temperature.
Following occurs:
 - Motorized valve opens and allows hot water to run through coil.
 - Indoor fan runs, blowing air through hydronic coil
 - Signal to water valve continues until room temperature rises above setpoint by 3°F (2°C).
 - After unit starts running and space gets warmer, hydronic valve closes and fan turns off.
3. After unit starts and space warms, adjust thermostat to cooler temperature setting, hydronic valve closes and fan turns off.
4. If warmer room temperature is desired, adjust thermostat to warmer temperature setting, which opens the hydronic valve and turn fan on.
5. If cooler room temperature is desired, adjust thermostat to cooler temperature setting. Hydronic valve closes and fan turns off.
6. Place thermostat or system switch to OFF position.
All operation should stop.

⚠ DANGER

Electrical shock hazard. Disconnect power to replacement units before servicing or accessing control compartment. Failure to do so could result in severe personal injury or death.

NOTICE

It is illegal to discharge refrigerant into the atmosphere. Use proper reclaiming methods and equipment when servicing a replacement unit.

Monthly Inspection And Maintenance

For optimum performance and reliability recommend following inspections and maintenance monthly. Units installed in harsh or dirty environments require more frequent inspections and maintenance.

- Disconnect power to unit and remove necessary access panels.
- Clean or replace the return air filter. Clean or replace the return air filter as needed.

Allowing dust to collect on the filter will cause unit to lose efficiency and eventually malfunction. Check filter at least once a month. Some environments may require more frequent replacement, depending on particulate in the air stream.

- Vacuum return air grille surface.
- Inspect & clean chassis interior for rodent or insect infestation.
- Clean & flush condensate drain pan.
- Ensure condensate drain is functioning properly.
- Inspect refrigeration tubing, especially braze joints, for signs of refrigerant leaks (oil residue). Repair if necessary.
- Inspect coil. Ensure dirt or debris have not collected on fins. Clean if necessary. Take care not to damage coil fins when cleaning. Use fin comb to straighten any bent fins.
- Examine control box. Ensure all wire connections are secure.
- Ensure blower wheels are secured to their motor shafts.
- Ensure dirt or debris have not collected on blower wheels. Use vacuum and soft brush to clean if necessary.
- If unit has hydronic option installed, inspect piping, especially braze joints, for signs of water leaks. Repair if necessary.
- Clean exterior of cabinet as desired with mild soap or household cleaner.
- In event limit switch opens and de-energizes electric heat, limit switch will need to be manually reset.

To reset switch:

- Remove control box cover.
- Locate limit switch.
- Push in reset button on switch face. See Figure 12.

Figure 12 Manual Reset Limit Switch

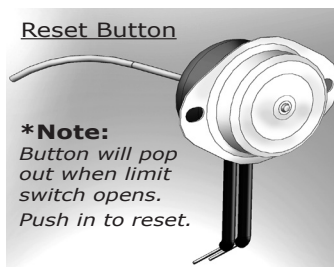

Seasonal Start-Up And Maintenance

At the beginning of cooling and heating seasons, complete mechanical check should be performed and maintenance/inspections performed as described below.

Disconnect power to unit and remove necessary access panels.

1. Perform inspections and maintenance defined in "Monthly start-up and maintenance."
2. Visually check equipment. Look for obvious changes in unit such as damaged coils or evidence of extended wear on any moving parts.
3. Check for unusual odors, oil leaks, or stains on or around coil and refrigerant lines. Presence of oil here may indicate potentially serious problem such as refrigerant leak (*example — burned motor windings, water, or refrigerant*).
4. Verify base pan is clean.
5. Inspect all electrical connections. Look for frayed wires and poor connections. Loose terminal ends will eventually fail, causing loss of performance or possible damage to equipment.
6. Check fan motor and blower assemblies. Some units may require drop of light oil to motors and/or bearing assemblies, look for oil cups. Verify set-screws and motor mounting hardware are tight.
7. Brush and/or vacuum centrifugal fan blades and blower cage assemblies, they must be clean to operate efficiently.
8. If unit has hydronic option installed, inspect piping, especially braze joints, for signs of water leaks. Repair if necessary.
9. Clean or replace return air filter.
10. Vacuum return air grille surface.
11. Inspect and clean chassis interior for rodent or insect infestation.

MAINTENANCE

12. Inspect coils. Use fin comb to straighten out any damaged fins. Coils must be clean for proper operation.

Do not use solvent-based cleaner to clean coils, some solvents produce noxious odor when unit is in operation.

13. Inspect and clean drain pan and drain line(s). Use of anti-fungicide tablet to keep condensate system free from bacterial contaminants is recommended.

14. Verify unit is level. Over time building and equipment may settle, causing shift in direction of condensate flow.

15. Replace access panels and reconnect electrical power.

16. Test unit operation.

TROUBLESHOOTING

Troubleshooting - Have qualified technician conduct troubleshooting procedures.

Symptom	Suggestion
No heat or cooling	<ul style="list-style-type: none"> • Verify unit has power and thermostat is satisfied. If thermostat is not satisfied, call your installing contractor or service contractor.
Thermostat calls for cooling, cool air is not coming from unit.	<ul style="list-style-type: none"> • Check for continuity between thermostat and unit. Verify 24 Vac is present across terminals C and R. • Verify water is flowing through water coil. Locate high pressure switch reset button, push the button. • Some units are equipped with LCDI (Leakage Current Detection Interrupt) line cord. Verify line cord is reset by pressing reset button at line cord plug. • Note: If indoor fan is operational and all above suggested procedures have been followed, and there is still no cooling being supplied by unit, contact trained heating and cooling professional.
Thermostat calls for heat, no heat comes from unit.	<ul style="list-style-type: none"> • Check to see if unit has power or thermostat has been satisfied. If unit has power and thermostat is satisfied, set thermostat above room temperature. • Units equipped with electric heaters have temperature limit switch to prevent electric heater from reaching unsafe temperatures. If after calling for heating heater is not energized, check for continuity across limit. If limit is open, replace with equivalent limit switch. Auto reset / Manual reset Switch.
Thermostat calls for heat while in heat pump mode, but no heated air comes from unit.	<ul style="list-style-type: none"> • If unit is equipped with LCDI Line Cord, verify it is not tripped. • While in heat pump mode, verify thermostat is not energizing O terminal. RetroAire units are designed to work in heat pump mode when 24Vac is present across Y and C. • Verify unit has power or thermostat has been satisfied. If unit has power and thermostat is satisfied, set thermostat above room temperature.

PERFORMANCE DATA CM / CW / WM **

Table 2 Performance Data

PERFORMANCE DATA CM / CW / WM **							
Voltage	Model	Cooling		Heat Pump		Indoor Airflow CFM (L/S)	Shipping Weight Lbs (Kg)
		Btuh (kW)	EER	Btuh (kW)	COP		
CM	CMHG08	10,000 (2.9)	12.2	11,000 (3.2)	4.3	400 (189)	140 (64)
	CMHG12	12,000 (3.5)	12.2	13,600 (4.0)	4.3	450 (212)	140 (64)
CW	CWHG10	10,000 (2.9)	12.2	11,000 (3.2)	4.3	400 (189)	160 (73)
	CWHG13	12,000 (3.5)	12.2	13,600 (4.0)	4.3	450 (212)	165 (75)
WM	WMHG09	10,000 (2.9)	12.2	11,000 (3.2)	4.3	400 (189)	150 (68)
	WMHG12	12,000 (3.5)	12.2	13,600 (4.0)	4.3	450 (212)	160 (73)

****Cooling - E.A.T. D.B. 80.6°F (27°C)
E.A.T. W.B. 66.2°F (19°C)
E.W.T. 86°F (30°C)**

****Heating - E.A.T. D.B. 68°F (20°C)
E.A.T. W.B. 59°F (15°C)
E.W.T. 68°F (20°C)**

FOAM - FIELD INSTALLATION

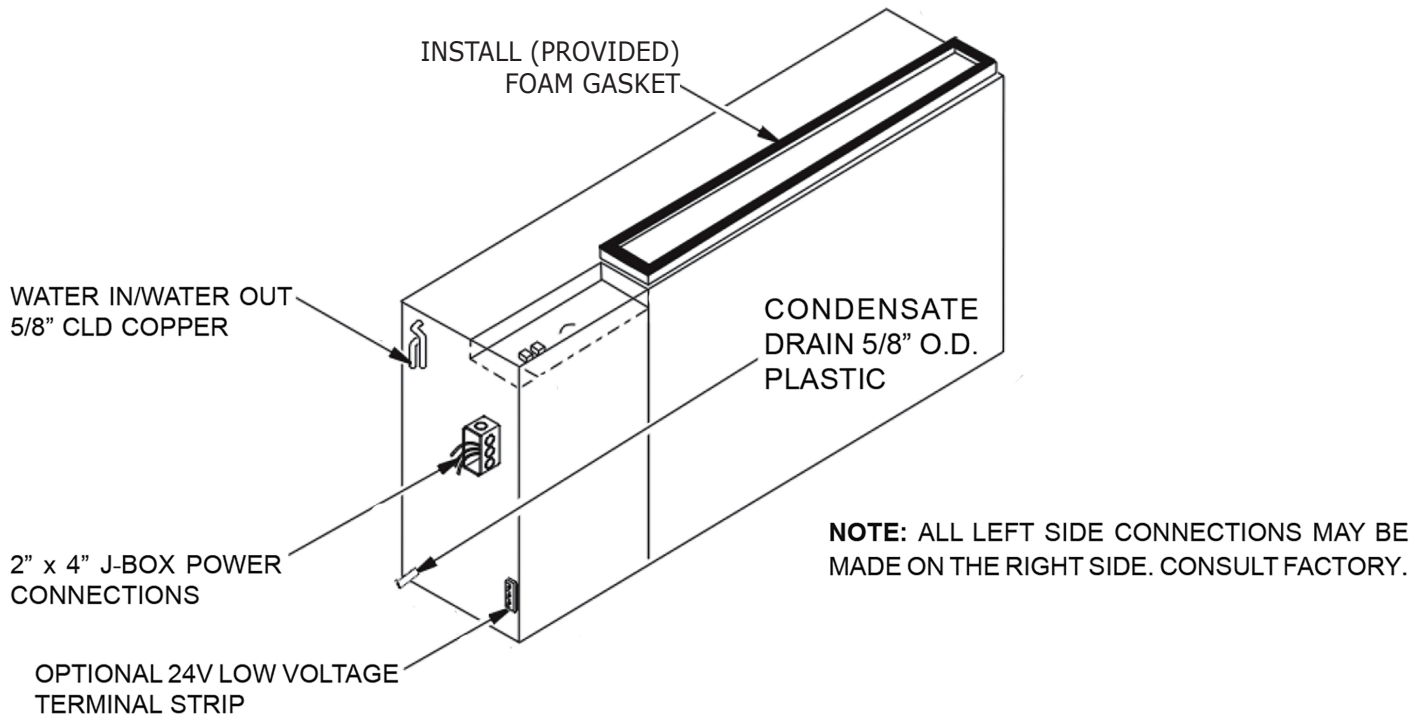

Illustrations are a depiction of the unit for general location of parts and are subject to change without notice.

ELECTRICAL SPECIFICATIONS

Table 3 CM - 8,000 BTU Electrical Specification

Power Supply Volt – 1-60		Compressor		Indoor Fan Motor		Electric Heat				Unit Electrical Ratings				
Volt	Min	RLA	LRA	FLA	Hp	Htr#	Volt	W	HA	TCA	THA	MCA	MOCP	Plug
115V	104	8	45.6	1.4	0.09	N/A	N/A	N/A	N/A	9.4	N/A	11.4	15	5-15P
208/ 230V	197	4	22.2	0.6	0.08	0	N/A	N/A	N/A	4.6	N/A	5.6	15	6-15P
						2	208	1636	7.9		8.5	10.6	15	6-15P
							230	2000	8.7		9.3	11.6		
						3	208	2454	11.8		12.4	15.5	20	6-20P
							230	3000	13.0		13.6	17.1		
						4	208	3271	15.7		16.3	20.4	25	6-30P
							230	4000	17.4		18.0	22.5		
						5	208	4089	19.7		20.3	25.3	30	6-30P
230	5000	21.7	22.3	27.9										
265V	240	3.32	18.8	.67	0.08	0	N/A	N/A	N/A	4.0	N/A	4.8	15	7-20P
						2	265	2655	10.0		10.7	13.4	15	7-20P
						3	265	3983	15.0		15.7	19.6	20	7-20P

Table 4 WM - 9,000 BTU Electrical Specifications

Power Supply Volt – 1-60		Compressor		Indoor Fan Motor		Electric Heat				Unit Electrical Ratings				
Volt	Min	RLA	LRA	FLA	Hp	Htr#	Volt	W	HA	TCA	THA	MCA	MOCP	Plug
115V	104	8	45.6	1.4	0.09	N/A	N/A	N/A	N/A	9.4	N/A	11.4	15	5-15P
208/ 230V	197	4	22.2	0.6	0.08	0	N/A	N/A	N/A	4.6	N/A	5.6	15	6-15P
						2	208	1636	7.9		8.5	10.6	15	6-15P
							230	2000	8.7		9.3	11.6		
						3	208	2454	11.8		12.4	15.5	20	6-20P
							230	3000	13.0		13.6	17.1		
						265V	240	3.32	18.8		.67	.08	0	N/A

ELECTRICAL SPECIFICATIONS

Table 5 CW - 10,000 BTU Electrical Specifications

Power Supply Volt – 1-60		Compressor		Indoor Fan Motor		Electric Heat				Unit Electrical Ratings				
Volt	Min	RLA	LRA	FLA	Hp	Htr#	Volt	W	HA	TCA	THA	MCA	MOCP	Plug
115V	104	8	45.6	1.4	0.09	N/A	N/A	N/A	N/A	9.4	N/A	11.4	15	5-15P
208/ 230V	197	4	22.2	0.6	0.08	0	N/A	N/A	N/A	6.2	N/A	5.6	15	6-15P
						2	208	1636	7.9		8.5	10.6	15	6-15P
							230	2000	8.7		9.3	11.6		
						3	208	2454	11.8		12.4	15.5	20	6-20P
							230	3000	13.0		13.6	17.1		
						4	208	3271	15.7		16.3	20.4	25	6-30P
							230	4000	17.4		18.0	22.5		
						5	208	4089	19.7		20.3	25.3	30	6-30P
							230	5000	21.7		22.3	27.9		
						265V	240	3.32	18.8		0.67	0.08	0	N/A
2	265	2655	10.0	10.7	13.4					15			7-20P	
3	265	3983	15.0	15.7	19.6					20			7-20P	

Table 6 CM 12,000 BTU Electrical Specifications

Power Supply Volt – 1-60		Compressor		Indoor Fan Motor		Electric Heat				Unit Electrical Ratings				
Volt	Min	RLA	LRA	FLA	Hp	Htr#	Volt	W	HA	TCA	THA	MCA	MOCP	Plug
115V	104	9.2	53	1.4	0.09	N/A	N/A	N/A	N/A	10.6	N/A	12.9	20	5-20P
208/ 230V	197	5.1	24	0.6	0.08	0	N/A	N/A	N/A	5.7	N/A	7.0	15	6-15P
265V	240	4.2	31.5	0.67	0.08	N/A	N/A	N/A	N/A	4.9	N/A	5.9	15	7-20P

Table 7 WM 12,000 BTU Electrical Specifications

















Power Supply Volt – 1-60		Compressor		Indoor Fan Motor		Electric Heat				Unit Electrical Ratings				
Volt	Min	RLA	LRA	FLA	Hp	Htr#	Volt	W	HA	TCA	THA	MCA	MOCP	Plug
115V	104	9.2	53	1.4	0.09	N/A	N/A	N/A	N/A	10.6	N/A	12.9	20	5-20P
208/ 230V	197	5.1	24	0.6	0.08	0	N/A	N/A	N/A	5.7	N/A	7.0	15	6-15P
265V	240	4.2	31.5	0.67	0.08	N/A	N/A	N/A	N/A	4.9	N/A	5.9	15	H-WIRE

Table 8 CW 13,000 BTU Electrical Specifications

Power Supply Volt – 1-60		Compressor		Indoor Fan Motor		Electric Heat				Unit Electrical Ratings				
Volt	Min	RLA	LRA	FLA	Hp	Htr#	Volt	W	HA	TCA	THA	MCA	MOCP	Plug
115V	104	9.2	53	1.4	0.09	N/A	N/A	N/A	N/A	10.6	N/A	12.9	20	5-20P
208/ 230V	197	5.1	24	0.6	0.08	0	N/A	N/A	N/A	5.7	N/A	7.0	15	6-15P
265V	240	4.2	31.5	0.67	0.08	N/A	N/A	N/A	N/A	4.9	N/A	5.9	15	7-20P

ELECTRICAL SPECIFICATIONS

Figure 13 NEMA Specifications Non / Locking / Receptacles

	125V		250V			265V		
	15(A)	20(A)	15(A)	20(A)	30(A)	15(A)	20(A)	30(A)
PLUG	 5-15 P	 5-20 P	 6-15 P	 6-20 P	 6-30 P	 7-15 P	 7-20 P	 7-30 P
RECEPTACLE	 5-15 R	 5-20 R	 6-15 R	 6-20 R	 6-30 R	 7-15 R	 7-20 R	 7-30 R

**EMI (COMFORTWAVE CHILLED WATER, ENVIRDAIR PTAC)
RETROAIRE (PTAC, VPRC/H, RQTH, WATER SOURCE HEAT PUMP CONSOLES)**

LIMITED WARRANTY

Effective Date September 1, 2017

**THIS LIMITED WARRANTY GIVES THE ORIGINAL PURCHASER ONLY SPECIFIC LEGAL RIGHTS AND YOU
MAY ALSO HAVE OTHER LEGAL RIGHTS WHICH VARY FROM STATE-TO-STATE AND PROVINCE-TO-
PROVINCE**

Keep this warranty certificate and the installation manual supplied with your unit for future reference.

Our Warranty

By this warranty statement ("Limited Warranty"), BCR International, Inc. ("BCR") issues limited warranties from the date of installation of the applicable EMI Product ("Product") to the Original Purchaser (as defined herein), subject to the terms and conditions stated below. As used in this Limited Warranty "Original Purchaser" shall mean, the end-user that purchased the new Product directly (a) from the EMI brand dealer, or (b) in the case of a newly constructed home, from the contractor who purchased such new Product directly from an EMI brand dealer or wholesaler for installation and use in the newly constructed home.

**EMI/RETROAIRE COMMERCIAL AND
RESIDENTIAL LIMITED WARRANTY**

The following limited warranty shall apply to only the Original Purchaser, at original installation site, of the EMI/Retrosaire Product, used without interruption by the Original Purchaser.

BCR warrants its Product used in commercial and residential applications to be free from defects in material and workmanship under normal usage for a period of one (1) year from the date of original installation. In the event that any part of such product is found to be defective in material or workmanship during this one-year period, then BCR will repair or replace, at its option, the defective part. Labor charges to diagnose, troubleshoot, remove and install repaired or replaced parts are the responsibility of the Original Purchaser along with any freight charges.

Unit Compressors of such Product shall be free from defects in materials and workmanship under normal usage and maintenance for a period of five (5) years from the date of original installation. In the event that the Unit Compressor is found to be defective in material or workmanship during this period, then BCR will repair or replace, at its option, the defective part. Labor charges to diagnose, troubleshoot, remove and install repaired or replaced parts are the responsibility of the Original Purchaser along with any freight charges.

.....
**LIMITATIONS/EXCLUSIONS – APPLIES TO ALL
WARRANTIES**

1. BCR will under no circumstances be responsible for and does not warrant damages or costs due to or arising from misapplication or misuse, improper installation or service,

components not supplied or approved by BCR, including, without limitation, indoor and outdoor units supplied by others, installation and normal maintenance such as, but not limited to, replacing air filters, cleaning, air flow adjustments, Products manufactured or distributed by BCR but installed outside the United States and Canada, damages from unauthorized alteration, application or improper operation, the failure of external wiring or other attachments and accessory products not integral to the Product or the use of parts not supplied or designated by BCR, damages or repairs as a consequence of shipping or handling, damages caused by faulty or interrupted power supply or electrical service, or damages caused by acts of God including, but not limited to, wind, hail, floods, lightning, earthquakes or other conditions beyond the control of BCR.

2. For all sales not subject to the Magnuson-Moss Warranty Act, there are no implied warranties of merchantability or fitness for a particular purpose, all of which are hereby specifically disclaimed. For all other sales, all implied warranties of merchantability and/or fitness for any particular purpose are limited in duration to the period of this Limited Warranty. The rights and remedies provided herein are exclusive and constitute the entire contract. This limited warranty and any optional extended warranties are granted only to the Original Purchaser and become null and void if payment for the goods or product is in default. This Limited Warranty is not transferable.

3. This Limited Warranty in no way can be considered as a guarantee of workmanship of an installer or repairman connected with the installation or service of the Product or as imposing on BCR liability of any nature for unsatisfactory performance as a result of faulty workmanship in the installation or service of the Product, which liability is expressly disclaimed.

4. BCR EXPRESSLY DISCLAIMS, AND IN NO EVENT SHALL BCR BE LIABLE (WHETHER FOR BREACH OF THIS LIMITED WARRANTY OR CONTRACT, FOR STRICT LIABILITY FOR NEGLIGENCE, OR OTHERWISE), FOR ANY SPECIAL, INCIDENTAL, PUNITIVE OR CONSEQUENTIAL DAMAGES, INCLUDING, WITHOUT LIMITATION, DAMAGES FOR LOSS OF PROFITS, LOSS OF GOODWILL, LOSS OF TIME OR CONVENIENCE, LOSS OF USE OF THE PRODUCT, THE COST OF A PRODUCT

**EMI (COMFORTWAVE CHILLED WATER, ENVIROAIR PTAC)
RETROAIRE (PTAC, VPRC/H, RQTH, WATER SOURCE HEAT PUMP CONSOLES)
LIMITED WARRANTY**

Effective Date September 1, 2017

**THIS LIMITED WARRANTY GIVES THE ORIGINAL PURCHASER ONLY SPECIFIC LEGAL RIGHTS AND YOU
MAY ALSO HAVE OTHER LEGAL RIGHTS WHICH VARY FROM STATE-TO-STATE AND PROVINCE-TO-
PROVINCE**

Keep this warranty certificate and the installation manual supplied with your unit for future reference.

RENTAL, COSTS OF GASOLINE, ELECTRICITY, TELEPHONE, TRAVEL OR LODGING, OR THE LOSS OF PERSONAL OR COMMERCIAL PROPERTY, WHETHER OR NOT ECR HAS BEEN ADVISED OF THE POSSIBILITY OF ANY SUCH DAMAGES.

PLEASE NOTE: Some states do not allow the exclusion or limitation of incidental or consequential damages, or limitations on how long an implied warranty lasts, so the above limitations and exclusions may not apply to you.

5. In no event shall ECR's obligations under this Limited Warranty exceed the purchase price of the Product. Any repairs or replacement performed under this limited warranty will apply to the original warranty period only and shall not in any way extend the statute of limitations for claims under this Limited Warranty.

MISCELLANEOUS

The Magnuson-Moss Warranty Act applies to "consumer" sales as contrasted with "commercial" sales. A consumer sale is one to a buyer for personal, family or household purposes and not for the purpose of resale.

By "implied warranties" we mean ones the law presumes to have been given by the seller even though they are not set out in writing.

"Fitness for a particular purpose" means the seller knows the particular purpose for which the buyer requires the goods, and the buyer relies on the seller's skill and judgment in making the purchase.

"Merchantable" means that the product is fit for the ordinary purposes for which that kind of product is used.

"Incidental" damages include expenses of inspection, obtaining substitute goods, transportation, etc.

"Consequential" damages include injury to persons or property resulting from a breach of warranty, and any loss from general or particular requirements known to us and which you cannot reasonably prevent.

If any provision of this Limited Warranty shall be determined to be illegal, unconscionable or unenforceable, all other terms and provisions hereof shall nevertheless remain effective and shall be enforced to the fullest extent permitted by law. The warranties made under this Limited Warranty are exclusive and may not be altered, enlarged or changed by a distributor, dealer, or other person whatsoever.

**PROCEDURE FOR OBTAINING WARRANTY
SERVICE**

For prompt warranty service, notify the installer who, in turn, will notify the EMI distributor from whom such installer purchased the Product. If this action does not result in warranty service, the Original Purchaser or installer should contact ECR Customer Service (see contact information below), giving full particulars in support of the claim. Alleged defective part(s) must be returned through trade channels in accordance with ECR's procedure currently in force for handling returned goods for the purpose of inspection or determining the cause of failure. ECR will furnish the new part(s) to an authorized EMI distributor who, in turn, will furnish the part(s) to the contractor who installed the Product.

ECR International, Inc.

2201 Dwyer Ave. • P.O. Box 4729 • Utica, New York
13504-4729 Ph: 315/797-1310
Customer Service Fax: 315/724-9319
E-Mail: info@ecrinternational.com
Web: www.ecrinternational.com

PN 240000278, Rev C



ECR International Inc. 2201 Dwyer Avenue, Utica, NY 13501
Tel. 800 253 7900
www.ecrinternational.com

All specifications subject to change without notice.
©2017 ECR International, Inc.