



UTICA BOILERS CCB-150 - Submittal

Engineer: _____

Project Name: _____

Project Location: _____

Contractor: _____

APPLICATION:

Modulating Gas fired water Combi boiler for indoor installation. Approved for closet or alcove installations. For use with natural or liquefied petroleum (LP/Propane) fuel gases, LP conversion kits available as option. Wall mounted – optional floor stand available. All boilers are factory assembled with controls and wiring and test fired to ensure dependable performance. Boiler shall be certified for Category I and Category III applications.

CERTIFICATION AND APPROVALS:

Copper tube heat exchanger is manufactured and tested in accordance with American Society of Mechanical Engineers (ASME) and certified by Canadian Standards Association (CSA). Copper tube heat exchanger is tested for maximum allowable working pressure of 43.5 psig in accordance with ASME boiler and pressure vessel code, section IV, rules for construction of heating boilers. A 30 psig safety relief valve is shipped standard.

BOILERS INCLUDE:

- Wall Mount Bracket
- Boiler is equipped with internal stainless steel brazed plate heat exchanger for potable hot water and automatic 3 way diverting valve to allow Domestic Hot Water Priority operation.
- Boiler includes internal pressure activated bypass loop to eliminate the need for primary secondary piping and includes internal factory installed and wired circulator pump.
- Digital Boiler Control:
 - ▶ Control system is PCB integral controller with LCD digital display that includes graphical interface.
 - ▶ Control senses supply water temperature and adjusts the boiler firing rate to deliver amount of heat needed.
 - ▶ Control can sense and display supply water temperature and indicate by icon when boiler is in central heating or domestic water mode.
 - ▶ Control has selectable Economy/Comfort mode. Comfort mode will maintain brazed plate heat exchanger at between 104°F to 140°F to speed DHW delivery.
 - ▶ Control can accept wired Outdoor Air sensor and has field selectable reset curves.
 - ▶ Control continuously monitors boiler during operation and standby modes. Control receives input data from dual temperature sensor, air pressure transducer, and optional outdoor air temperature sensor (when used) to adjust modulation rate accordingly.
 - ▶ Control can power and accept input from field supplied LWCO device.



ECR international
EST. 1920
A Family of Heating & Cooling Brands.



- Boiler Combustion System:
 - ▶ The Gas valve is a modulating valve capable of firing from 100% input firing rate to 33% input firing rate.
 - ▶ Induced draft blower is variable speed. PCB uses air pressure transducer to vary blower speed.
 - ▶ Burners and manifold shall be constructed of stainless steel.
 - ▶ Ignition system shall be direct spark single rod flame sensing.
- Primary Heat Exchanger:
 - ▶ Boiler’s primary heat exchanger is constructed of copper tube with copper fins, stainless steel support plates and is covered with a high temperature protective coating.
- Electrical:
 - ▶ 120 volts AC, 60 Hertz, 1-phase; less than 12 amps.
 - ▶ Factory wired 6-foot appliance cord with male plug end.
 - ▶ Low voltage terminal strip for Thermostat, and optional Outdoor Air Sensor and LWCO
- Other:
 - ▶ Refer to all local codes and jurisdictional requirements for installation of field supplied anti-scald valve.
- Optional Equipment:
 - ▶ Floor mounting stand
 - ▶ Outdoor Air Sensor
 - ▶ Direct Vent Termination Kit
 - ▶ LP Conversion kit



| Size | | Boiler Input Rate (MBH) ⁽¹⁾ | | Heating Capacity (MBH) ⁽¹⁾⁽²⁾ | Net AHRI Rating, Water (MBH) ⁽¹⁾⁽³⁾ | AFUE ⁽²⁾ |
|----------------|--|--|---------|--|--|---------------------|
| | | Maximum | Minimum | | | |
| CCB-150 | | 150 | 50 | 130 | 110 | 85.0 |

AHRI CERTIFIED
www.ahridirectory.org

**SEA LEVEL RATINGS
NATURAL AND PROPANE GASES**

⁽¹⁾ 1000 Btu/hr (British Thermal Units Per Hour)
⁽²⁾ Heating Capacity and AFUE (Annual Fuel Utilization Efficiency) are based on DOE (Department of Energy) test procedures.
⁽³⁾ Net AHRI Ratings based on piping and pickup allowance of 1.15. Contact Technical Support before selecting boiler for installations having unusual piping and pickup requirements, such as intermittent system operation, extensive piping systems, etc.

- USA - Input rates are derated 4% for each 1000 ft (300m) above sea level, beyond 2000 ft. (600m).
- CANADA - Ratings above used for elevations up to 200 ft (600m) above sea level.
 - For elevations between 2000 ft (600m) and 4500 ft (1350m), derate 10% using high altitude kit.
 - Contact Provincial authority having jurisdiction for installations above 4500 feet (1350m) above sea level.

Boiler water content: CCB-150 0.396 gallons.

DHW Brazed Plate Capacity :

Flow Rate at 40°F Temperature rise = 6.3 gal/min

Flow Rate at 70°F Temperature rise = 3.6 gal/min



Overall Dimensions



Top View

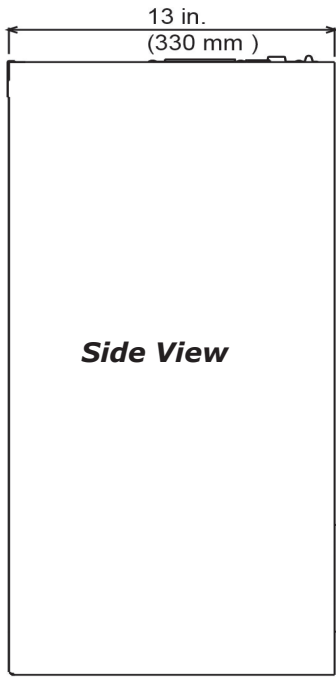
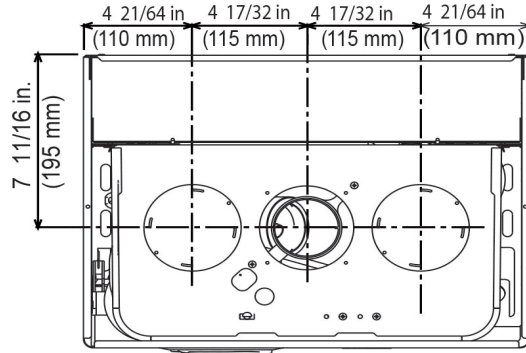

Side View

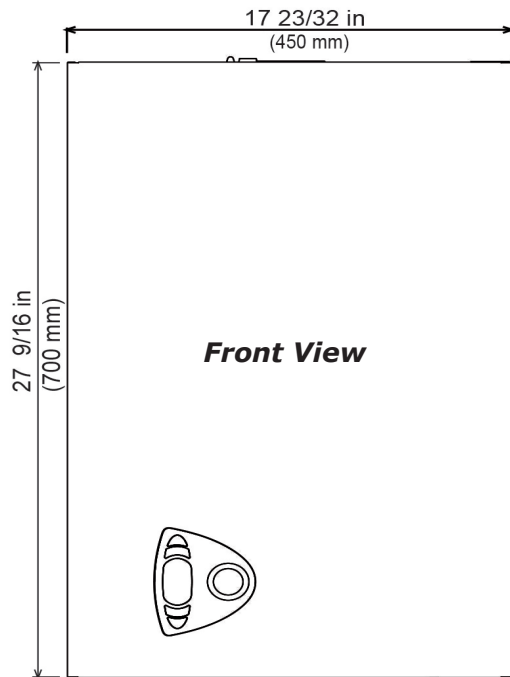

Front View

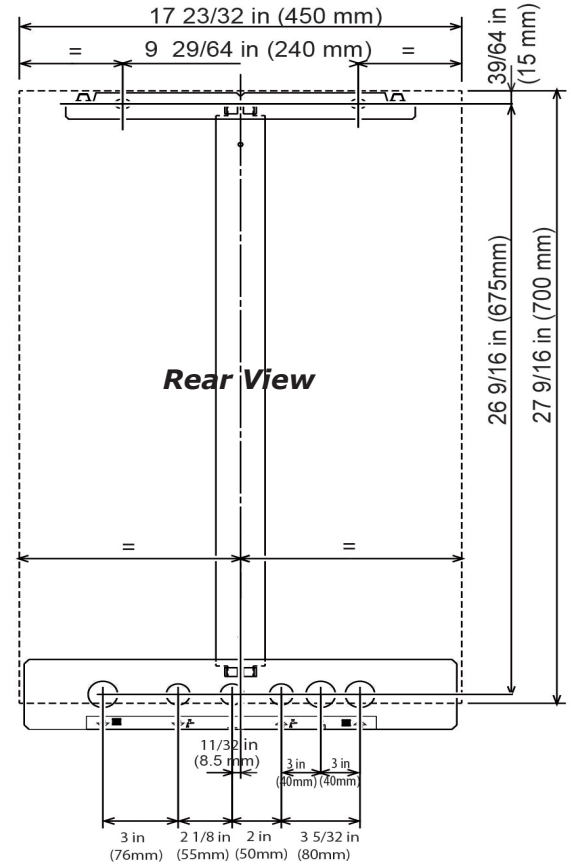

Rear View

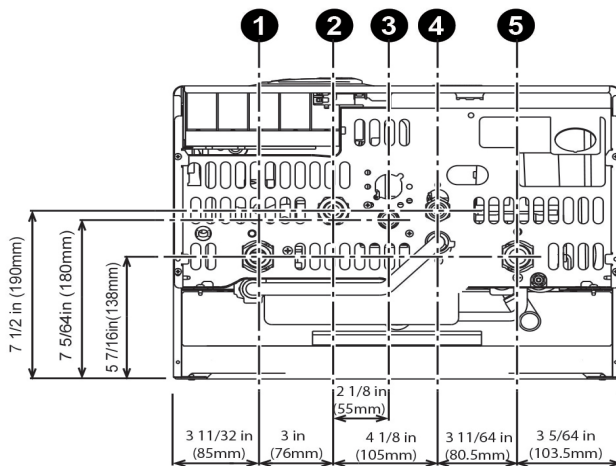

Bottom View

- 1 = 1" MPT Supply Water to Heating System (Out)**
- 2 = 3/4" MPT Tap Water Outlet**
- 3 = 3/4" FPT Gas Inlet**
- 4 = 3/4" MPT Tap Water Inlet**
- 5 = 1" MPT Return Water From Heating System (IN)**





| Boiler Clearances | | |
|---------------------------|--------------------------------------|---------------------------|
| Dimension | Combustible Materials ⁽¹⁾ | Service ⁽¹⁾⁽²⁾ |
| Top (A) | 16" (41cm) | 12" (30cm) |
| Left Side (B) | 0" (0 cm) | 1" (3 cm) |
| Right Side (C) | 0" (0 cm) | 1" (3 cm) |
| Front (D) | 0" (0 cm) | 1" 3 cm) |
| Back (E) | 0" (0 cm) | 0" (0 cm) |
| Bottom (F) | 0" (0 cm) | 4" (12 cm) |
| Combustion Air/ piping | 0" (0 cm) | 3/8" (1 cm) |
| Vent piping | 6" (15 cm) | 6" (15 cm) |

⁽¹⁾ Required distances measured from boiler jacket.
⁽²⁾ Service, proper operation clearance recommendation.

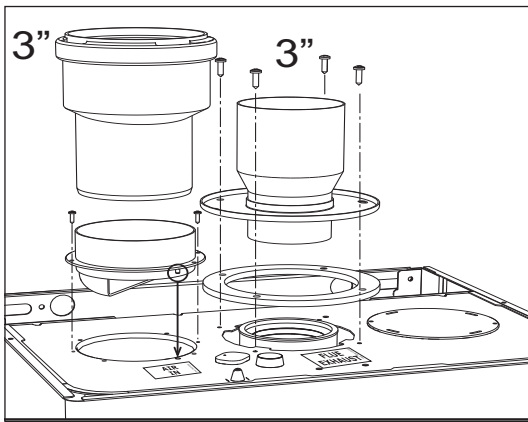

| Combustion Air and Vent Pipe Fittings Category I (Chimney Vent) | | |
|---|---|--|
| Item | Material | Standards |
| Vent Pipe & Fittings | Type B Vent | UL 441, ULC S605 |
| | Masonry Chimney - must conform to proper sizing and materials | National Fuel Gas Code, ANSI Z223.1/NFPA 54 |
| Combustion Air | Stainelss Steel, PVC, CPVC, PP | ANSI/ASTM D2564, ANSI/ASTM F493, UL 1738/ULC636-08 |

Horizontal Venting requires field supplied appliance adapter for the boiler flue outlet. Boiler is provided with a 3" vent connection, 3" x 4" increaser must be field sourced for chimney application. This does not mean that the connection to the chimney will always be 4".

| Combustion Air and Vent Pipe Fittings Category III (Horizontal Vent & Direct Vent) | | | | | | |
|--|------------|----------|------------|------------|--|---|
| Type | Item | Diameter | Min Length | Max Length | Material | Standards |
| Direct Vent | Vent | 3" | 5 ft | 65 ft | AL294C Stainless Steel, Aluminum | UL1738, ULC S636 |
| | Air Intake | 3" | 5 ft | 65 ft | Stainless Steel, PVC, CPVC, PP, Aluminum | ANSI/ASTM D2564, ANSI/ASTM F493, UL1738/ULC636-08 |
| Category III | Vent | 3" | 5 ft | 65 ft | AL294C Stainless Steel Aluminum | UL1738, ULC S636 |

Equivalent Length of Venting Components:

- 5 ft. equivalent for a 3" 90° elbow
- 2½ ft. equivalent for 3" 45° elbow

