

REVISIONS				
REV.	DATE	CN	DESCRIPTION	Chg. By
A	10/30/2014	140327	RELEASE TO PRODUCTION.	JAM

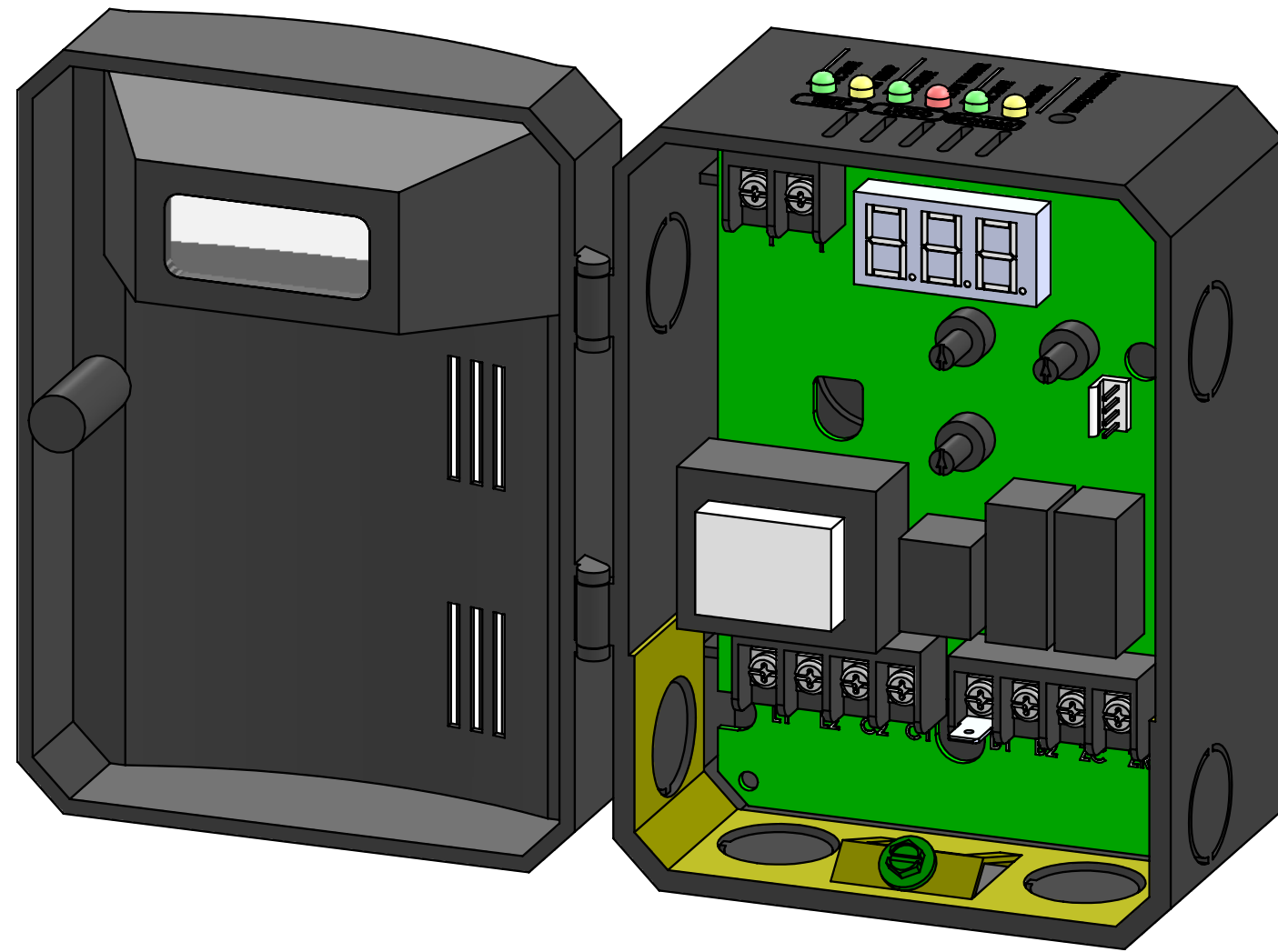

Vendor: Hydrolevel Company

Model: Hydrostat 3250-PLUS

Hi-Limit / Lo-Limit & LWCO Control with 12" Long Sensor Lead Wire (48-3150-60).

Vendor P/N (Control and sensor) 48-3259E

1. Suffix "E" indicates Left-Side Well Mounting
2. Control to be bulk-packed with sensor wire attached (not shown)
3. Vendor to supply "Installation Instructions and Operating Manual" (12 pg.) with each control order.
4. Control to be used with Hydrostat Well (LIKE 48-202) - ECR P/N 240009115 (OR EQUIVALENT)
5. Control to be certified by a 'Nationally Recognized' agency (UL/CSA/ETL /etc.) US. LWCO to comply with ANSI/UL-353 (US).

THIS DOCUMENT AND ITS CONTENTS CONSTITUTE PROPRIETARY TRADE SECRETS OF ECR INTERNATIONAL, INC. AND MAY NOT BE REPRODUCED, DISTRIBUTED OR USED IN ANY MANNER WITHOUT THE EXPRESS WRITTEN CONSENT OF AN AUTHORIZED REPRESENTATIVE OF ECR INTERNATIONAL, INC.

TITLE <b>CTRL,TEMP          LMT/LWCO,W/SNSR,HL3          250+</b>		 <b>ECR INTERNATIONAL Inc.</b> 2201 Dwyer Avenue, Utica, NY 13501 PHONE:(315)797-1310 - FAX(315)797-5372 www.ecrinternational.com	
REFERENCE ASME Y14.5M-1994 FOR GEOMETRIC DIMENSIONING. ALL DIMENSIONS IN INCHES. DRAWING NOT TO BE SCALED. NON-BASIC DIMENSIONAL AND ANGULAR TOLERANCES UNLESS OTHERWISE NOTED: DECIMALS: X.X - ±0.1 X.XX - ±0.03 X.XXX - ±0.005 FRACTIONAL: ±1/32 ANGULAR: MACHINED - ±1° ANGULAR: FORMED - ±2°	<b>SCALE</b> 3:4 <b>DATE</b> 10/29/2014	<b>CHKD</b> FS <b>APPD</b> JK	<b>SHEET</b> 1 of 1 <b>REV</b> A
<b>SIZE</b> B <b>DWG NO.</b> 240010867			



## MODEL 3250-Plus

**Temp Limit / LWCO Control  
with Thermal Targeting™  
for Water Boilers**

120 VAC Operating Voltage

PATENT NO. 7,891,572

# INSTALLATION INSTRUCTIONS and OPERATING MANUAL

- **Saves Fuel** – Features Thermal Targeting™ technology and Thermal Pre-Purge capability
- **Outdoor Reset Ready** – Provides Outdoor Reset and Warm Weather Shut-Down capability with the addition of Hydrolevel OS-100 Outdoor Sensor Kit (sold separately)
- **Universal Design** – Replaces common cold-start and triple-action Aquastats\*
- **Operating Indicators** – LEDs, Dynamic Display and Test Button provide continual and on-demand status checks
- **Prioritizes Domestic Hot Water** – Gives priority to low limit setting or to calls from indirect water heater
- **Reduces Condensation** – Holds circulator off until boiler reaches 125°F

\*Aquastat is a registered trademark of Honeywell International, Inc.

## Three Function Design

### Temperature Limit Control

Designed for cold start and tankless coil boilers.

### Low Water Cut-Off

Provides protection against potentially dangerous low water conditions when installed with the Hydrolevel Electro-Well™ (see page 2 for details).

### Boiler Reset Control

- **Thermal Targeting** – On-board micro-processor adjusts boiler temperature based on heating demand.
- **Outdoor Reset Ready** – Compatible with Hydrolevel OS-100 Outdoor Sensor Kit (sold separately) for outdoor reset and warm weather shut-down functionality.



### WARNING

**Electrical shock hazard.** To prevent electrical shock, death or equipment damage, disconnect power supply before installing or servicing control. Only qualified personnel may install or service this control in accordance with local codes and ordinances. Read instructions completely before proceeding.



### CAUTION

To prevent serious burns, boiler should be thoroughly cooled before installing or servicing control.



### WARNING

**Frozen pipes/water damage.** Central heating systems are prone to shut down as a result of power or fuel outages, safety related fault conditions or equipment failure. Installation of freeze protection monitoring or other precautions is recommended for unattended dwellings in climates subject to sustain below-freezing temperatures.

**HYDROLEVEL  
COMPANY**

83 Water Street • New Haven, CT 06511 • Phone (203) 776-0473 • FAX (203) 773-1019 • [www.hydrolevel.com](http://www.hydrolevel.com)

## IMMERSION WELLS

Fuel Smart HydroStat can be installed on a Hydrolevel Electro-Well™ or on an existing immersion well already in the boiler. **IMPORTANT:** The control will only provide low water cut-off protection when installed on an Electro-Well™.

### Installing HydroStat with Hydrolevel Electro-Well™

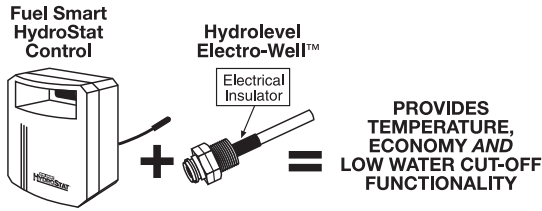

When installed on an Electro-Well™ (sold separately), the Low Water Cut-Off function is automatically activated. Heat transfer grease should not be used. **NOTE:** For proper operation, there must be 1/2" clearance between the copper well tube and any furnace within the boiler. **See Electro-Well™ models on page 15.**

### Installing HydroStat with Standard Immersion Well

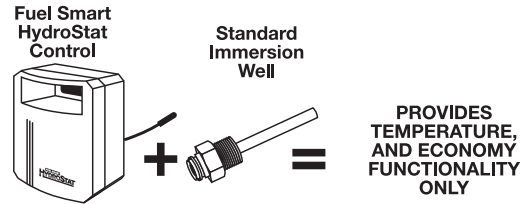

When installing on a standard immersion well, the LWCO function should be turned off (see page 10 for instructions). A buildup of heat transfer grease or other coatings in older wells can interfere with continuity between the sensor and the well causing a false low water shutdown. Turning off the LWCO function will prevent this from occurring.

## MOUNTING THE CONTROL

**IMPORTANT** Make sure that the immersion well or Electro-Well™ is installed in the boiler manufacturer's designated temperature limit control tapping.

**NOTE:** If installing an Electro-Well™, pipe sealing compound should be used. Teflon tape is not recommended.

**STEP 1** Two mounting positions are available on the back of the control (Fig. 1). Select which of the two positions (2 knockouts) is best for the location of the control. Remove the knockout.

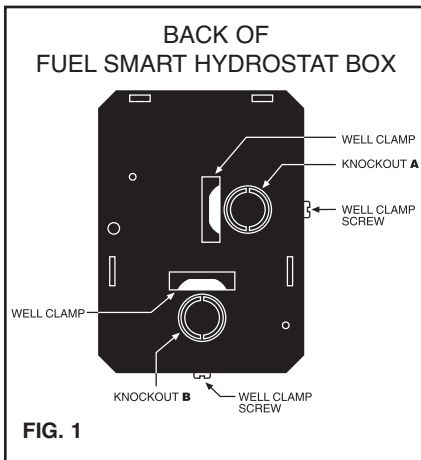

**STEP 2** Place control on the well. While holding box against well nut, tighten well clamp screw. (Fig. 2)

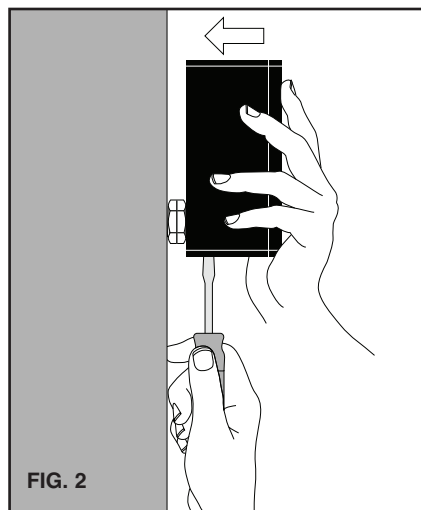

**STEP 3** Insert sensor ALL THE WAY into well through the knockout (A or B) you have chosen. (Fig. 3)

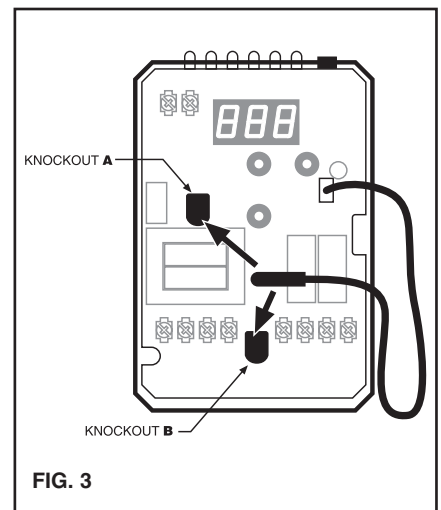

**NOTE:** In the case of space restrictions, the Fuel Smart HydroStat control may be mounted in a horizontal orientation without any loss of function. Hydrolevel recommends vertical mounting, when possible, for proper orientation of LED display.

**REMOTE MOUNTING KITS** are available separately for mounting the Fuel Smart HydroStat control box in a remote location. Each kit includes mounting hardware and a remote sensor. See page 16 for kit options.

## WIRING

**WARNING** Electrical shock hazard. To prevent electrical shock, death or equipment damage, disconnect power supply before installing or servicing this control.

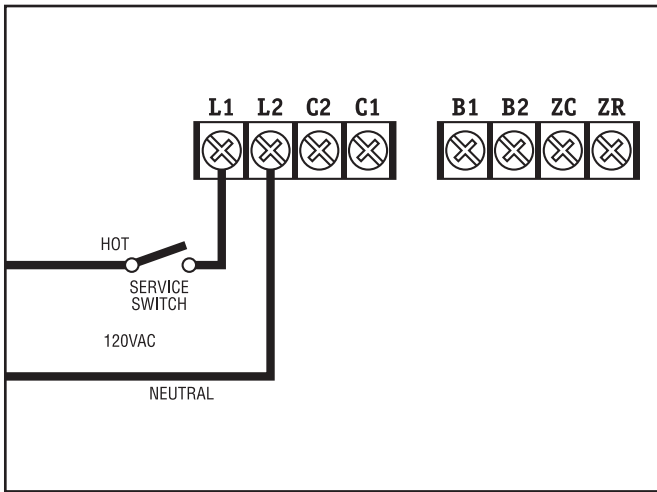

**STEP 1** Connect 120 VAC Hot to terminal L1. Connect 120 VAC Neutral to terminal L2. Disconnect means and overload protection as required (provided by others).

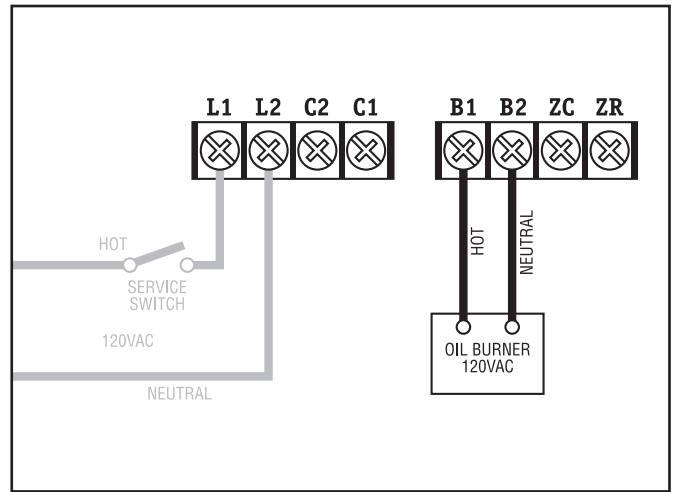

**STEP 2** Connect the burner circuit to B1-B2. (B2 is neutral.)

**Select the Diagram that  
Matches your System Configuration  
on Pages 4, 5 or 6**

# WIRING

**WARNING** Electrical shock hazard. To prevent electrical shock, death or equipment damage, disconnect power supply before installing or servicing this control.

**NOTE:** For proper operation of the boiler reset function, all heating thermostats must input to **T-T** or **ZC-ZR** terminals as indicated below. Jumping the T-T terminals and wiring the thermostat to the primary will override the economy feature.

## STEP 3A: HEATING ONLY – No Indirect Water Heater

CHOOSE 1 OR 2 BELOW

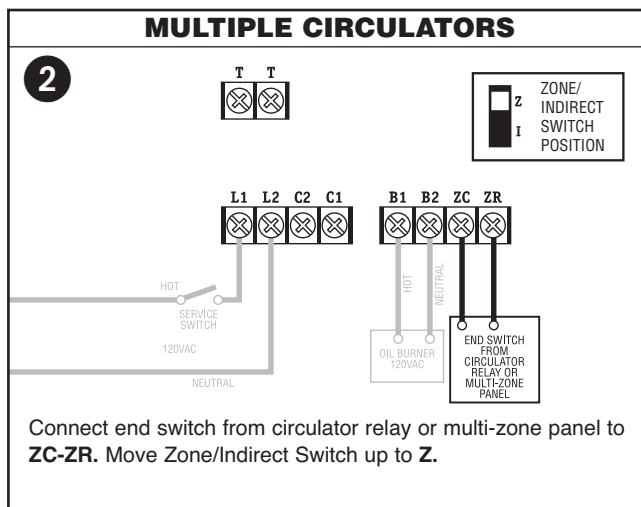
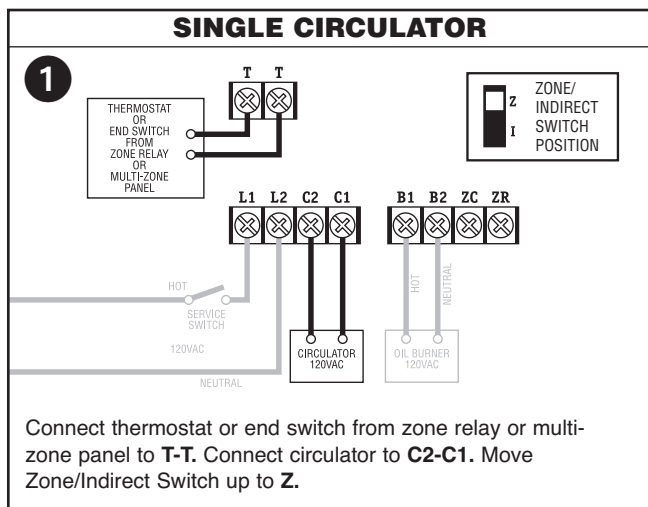

## STEP 3B: HEATING and Indirect Water Heater

**IMPORTANT:** When installing with an indirect water heater, the Zone/Indirect Switch must be set in the **I** position. When set in the **I** position, calls to **ZC-ZR** will bypass the Thermal Targeting feature and allow the boiler to fire to the high limit setting to heat the indirect tank. The indirect signal must be separate from all heating zone signals. If you choose not to separate the indirect signal from the heating zones, the Economy Feature should be turned OFF to ensure that the boiler supplies adequate temperature to heat the indirect tank (see page 7).

CHOOSE FROM 3 THROUGH 8 BELOW OR ON PAGE 5 OR 6

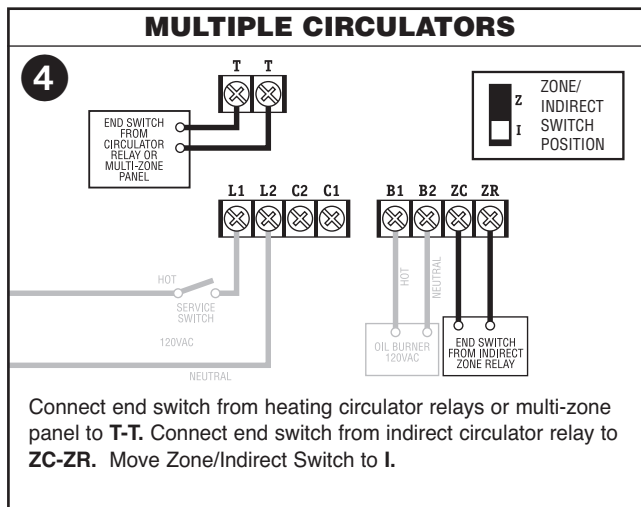
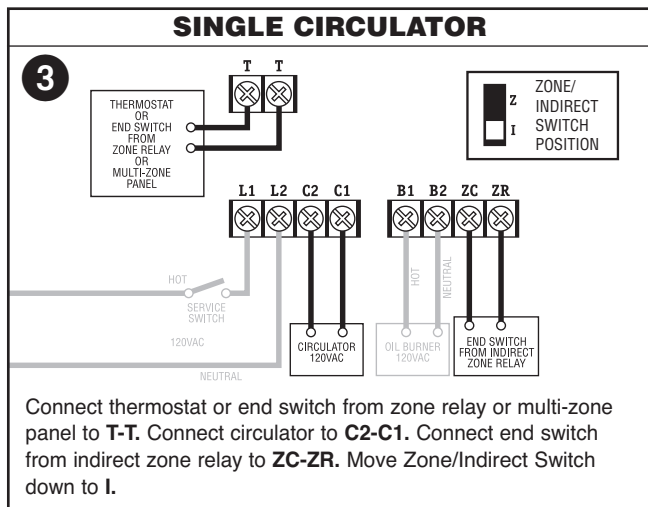

# WIRING

**WARNING** Electrical shock hazard. To prevent electrical shock, death or equipment damage, disconnect power supply before installing or servicing this control.

**NOTE:** For proper operation of the boiler reset function, all heating thermostats must input to T-T or ZC-ZR terminals as indicated below. Jumping the T-T terminals and wiring the thermostat to the primary will override the economy feature.

## STEP 3B: HEATING and Indirect Water Heater – continued

### MULTIPLE CIRCULATORS — Typical Zone Panel with Priority Zone

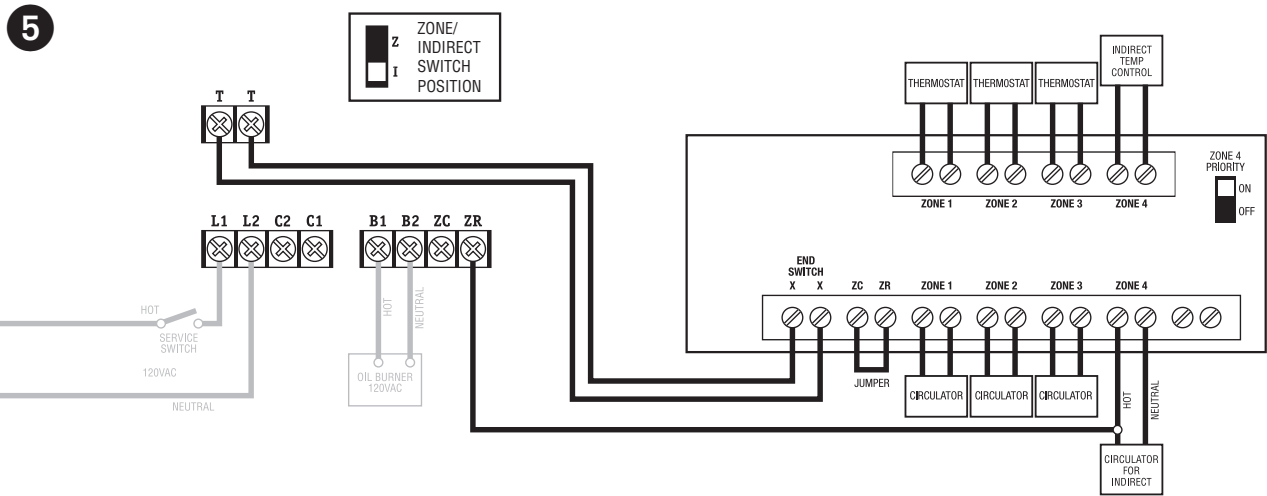

**NOTE:** The wire from ZR to the hot terminal of the indirect circulator will ensure that indirect calls will fire to limit and receive priority over heating calls.

### SINGLE CIRCULATOR — Multiple Zone Valves including Indirect, No Zone Control Panel

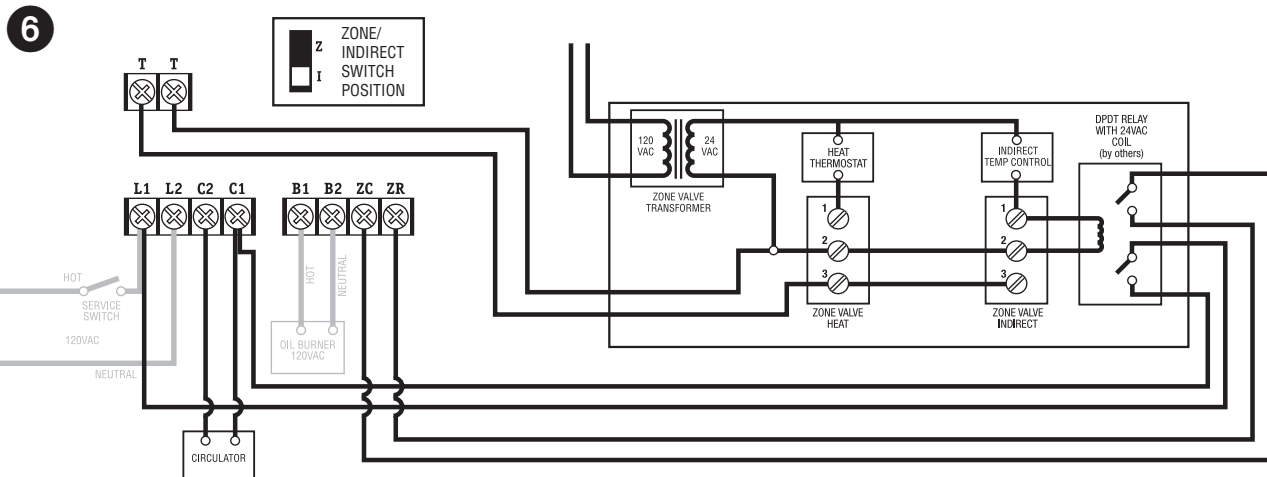

**NOTE:** When using zone valves for both heat and indirect, the calls must be separated in order to prioritize indirect calls. This can be accomplished by using a general purpose relay as shown above. However, for ease of installation, a zone control panel is recommended (see wiring diagram 7 on next page).



# WIRING

**WARNING** Electrical shock hazard. To prevent electrical shock, death or equipment damage, disconnect power supply before installing or servicing this control.

**NOTE:** For proper operation of the boiler reset function, all heating thermostats must input to **T-T** or **ZC-ZR** terminals as indicated below. Jumping the T-T terminals and wiring the thermostat to the primary will override the economy feature.

## STEP 3B: HEATING and Indirect Water Heater - continued

### SINGLE CIRCULATOR — Typical Multiple Zone Valve Panel with Indirect

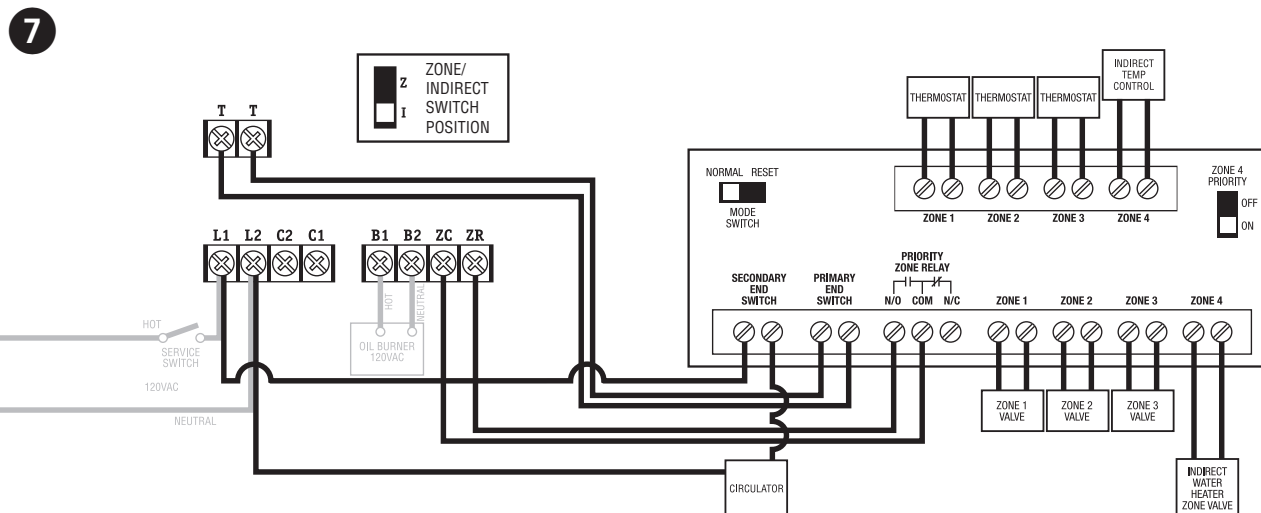

**NOTE** – If a Zone Valve Control Panel has no priority zone: To ensure adequate boiler temperature to satisfy the domestic hot water tank, it may be necessary to turn the Economy Feature off.

### MULTIPLE CIRCULATORS — Typical Three Zone Switch Relay

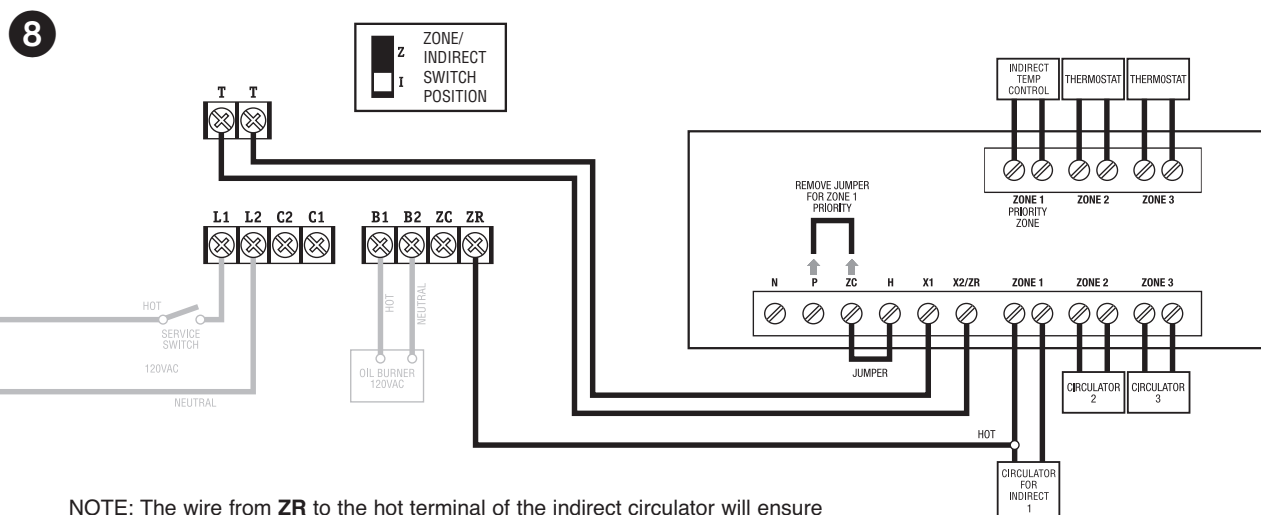

**NOTE:** The wire from **ZR** to the hot terminal of the indirect circulator will ensure that indirect calls will fire to limit and receive priority over heating calls. Taco's SR503 combines ZR and X2.

# SETTING THE CONTROL

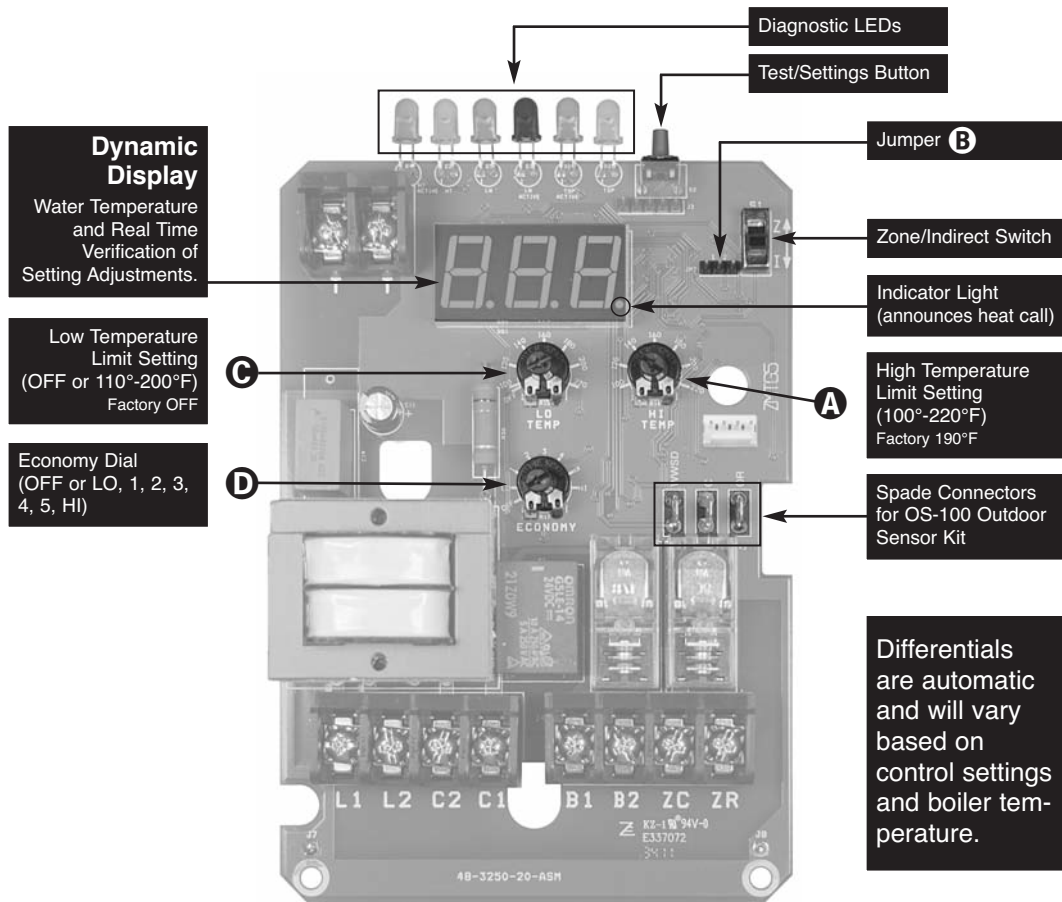

**NOTE:** Settings can be checked using the TEST/SETTINGS Button. See page 11 for details.

## Setting the High Limit

The high limit is factory set at 190°F. To adjust, turn the HI TEMP Dial **A** until the desired setting is displayed. (Setting range: 100°-220°F)

## Setting the Low Limit

The low limit is designed to maintain temperature in boilers equipped with tankless coils used for domestic hot water. The low limit is factory set to OFF. Prior to adjusting, remove the jumper (not equipped on all units) **B**. Then turn the LO TEMP Dial **C** clockwise until the desired temperature limit setting should be at least 10° below the high limit setting.

**NOTE:** For cold start operation, the low limit must be turned OFF. **IMPORTANT:** If low limit temperature cannot be set above 140°F, remove jumper **B**. (Setting range: OFF or 110°-200°F).

## Setting the Economy Feature

The Economy Feature is factory set for a 1 zone heating system. To adjust, turn the ECONOMY Dial **D** until the number displayed equals the number of heating zones. **Do not include indirect water heaters in the number of heating zones.** The Economy Feature conserves fuel by reducing

boiler temperature (see “How Thermal Targeting Works” on page 8). If the heating system is unable to supply needed heat to the house, the ECONOMY Dial should be turned to a lower setting (example: In a three zone house, turn the dial to 2 or 1). Conversely, if the boiler provides adequate heat, added fuel savings can be achieved by selecting a higher setting (example: 4 or 5). If the heating and indirect water heater signals were not separated when wiring the control, the Economy Feature should be turned OFF to ensure the boiler supplies adequate temperature to heat the indirect tank.

## Setting the Zone/Indirect Switch

See WIRING on page 4-6.

### SETTING

- OFF** Disables economy function. Will allow boiler to fire until hi-limit temp is reached and re-fire with a 10° subtractive differential.
- LO** Provides lowest level of fuel savings. Use this setting only if the house does not stay warm at higher settings.
- 1** Recommended setting for single zone systems
- 2** Recommended setting for Two zone systems
- 3** Recommended setting for Three zone systems
- 4** Recommended setting for Four zone systems
- 5** Recommended setting for Five zone systems
- HI** Provides highest level of fuel savings



## SYSTEM START-UP

At initial start up, with the Economy Feature active, the control establishes a 145°F target temperature. To test the high limit shut-off function, the Economy Dial must be turned to OFF. Once tested, restore the Economy setting. If the heating demand is high, the target will increase over time to satisfy the heat load.

### NOTE:

• *Smart DHW Priority:* During a call from an indirect water heater, the control will de-energize the circulator contacts (C1/C2) to heat only the indirect tank ensuring an adequate supply of domestic hot water. The control will re-energize the circulator when the indirect tank is satisfied or if the boiler temperature reaches 170°F. If the indirect call continues for 45 minutes, the control will override the priority function energizing the circulator to provide space heating.

## HOW THERMAL TARGETING WORKS

Thermal Targeting technology analyzes thermostat activity and continually evaluates how much heat the house requires. When it is very cold outside, the heat demand is high and the Fuel Smart HydroStat will raise the boiler's Target temperature to provide needed heat to the home. When the outside temperature is milder, the heat demand is lower. During these periods, the Fuel Smart HydroStat will lower the boiler's Target temperature – saving fuel – while continuing to provide comfort to the house.

## OPTIONAL FEATURES

NOTE: The Program Mode –  $P_{r} \square$  – is accessed by turning the LO TEMP dial to a position just above OFF.

### Thermal Pre-Purge

Thermal Pre-Purge is designed to maximize boiler efficiency. When activated, the control will supply latent heat that may remain in the boiler from a previous run cycle to the heating zone that is now calling. The control monitors how quickly the boiler temperature is declining and activates the burner only when it determines that the latent heat is insufficient to satisfy the call. During the purge cycle, the display will indicate  $P_{L} \square$ . This feature works with single-zone and multi-zone heating systems utilizing circulators or zone valves. No change in wiring is needed.

#### *To activate Thermal Pre-Purge*

1. Turn the LO TEMP dial to access the Program Mode – indicated in the display as  $P_{r} \square$
2. Turn the HI TEMP dial to select feature  $\downarrow$
3. Push the Test/Settings Button to turn Thermal Pre-Purge  $\square \square$  or  $\square \square \square$
4. Reset LO TEMP and HI TEMP settings to desired temperatures (see page 7)

### Degrees Fahrenheit or Celsius

The control has the ability to operate in degrees Fahrenheit or Celsius. When operating in Celsius, a  $\square$  will appear in the display next to the temperature whenever the temperature is below 100 degrees.

#### *To change between degrees Fahrenheit and degrees Celsius*

1. Turn the LO TEMP dial to access the Program Mode – indicated in the display as  $P_{r} \square$
2. Turn the HI TEMP dial to select feature  $\square$
3. Push the Test/Settings Button to  $\square$  for Celsius or  $\square$  for Fahrenheit
4. Reset LO TEMP and HI TEMP settings to desired temperatures (see page 7)

MORE OPTIONAL FEATURES ON NEXT PAGE

### Manual Reset Low Water Cut-Off

---

The low water cut-off operation on the HydroStat can be set to operate in automatic (default) or manual reset mode. When in manual reset mode, the control will shut-down the burner immediately when a low water condition is detected. If the low water condition is sustained for 30 seconds, the low water light will blink, indicating that the control has locked out the burner. The control can only be reset by pushing the Test Settings button on the top of the control. The manual reset feature meets CSD-1 code requirements.

**IMPORTANT:** The system must be checked by a qualified heating professional prior to resuming operation.

**WARNING: DO NOT ADD WATER UNTIL THE BOILER HAS FULLY COOLED.**

#### ***To activate Manual Reset LWCO mode***

1. Turn the LO TEMP dial to access the Program Mode – indicated in the display as  $P_{r} \square$
2. Turn the HI TEMP dial to select feature  $\exists$
3. Push the Test/Settings Button to  $\overline{P}$  for Automatic Reset Mode or  $\overline{b}$  for Manual Reset Mode
4. Reset LO TEMP and HI TEMP settings to desired temperatures (see page 7)

**To Test the Manual Reset Feature:** Press and hold the Test/Settings button located on the top of the control for 30 seconds to simulate a low water condition. After 30 seconds, the Low Water light will blink indicating that the control is locked out. To reset the lock-out condition, press the Test/Settings button momentarily.

### Circulator Activation Options

---

When in the default mode, the HydroStat activates the circulator (**C1/C2** contacts) on calls to **TT**. The control can be programmed to activate the circulator on calls to **ZC/ZR** in place of, or in addition to, calls to **TT**.

#### ***To change how the Circulator is activated***

1. Turn the LO TEMP dial to access the Program Mode – indicated in the display as  $P_{r} \square$
2. Turn the HI TEMP dial to select feature  $\overline{4}$
3. Push the Test/Settings Button to select between the following options:
  - $\overline{P}$  - Circulator on **TT** call only
  - $\overline{b}$  - Circulator on **ZC/ZR** call only
  - $\overline{c}$  - Circulator on both **TT** & **ZC/ZR** calls
4. Reset LO TEMP and HI TEMP settings to desired temperatures (see page 7)

### Circulator Hold Off (Enhanced Condensing Protection)

---

To reduce the potential for condensing, on a call for heat the control will allow the boiler to heat to 125°F prior to energizing the circulator. Once energized, the circulator will remain on for the duration of the heating call unless the boiler temperature drops below 115°F. If this occurs, the circulator will re-energize when the boiler returns to 125°F.

#### ***To activate Circulator Hold Off***

1. Turn the LO TEMP dial to access the Program Mode – indicated in the display as  $P_{r} \square$
2. Turn the HI TEMP dial to select feature  $\overline{5}$
3. Push the Test/Settings Button to turn Circulator Hold Off  $\overline{on}$  or  $\overline{OFF}$
4. Reset LO TEMP and HI TEMP settings to desired temperatures (see page 7)

MORE OPTIONAL FEATURES ON NEXT PAGE

## OPTIONAL FEATURES continued

### Low Water Cut-Off Function

#### To turn off Low Water Cut-Off

1. Turn the LO TEMP dial to access the Program Mode – indicated in the display as *PR*
2. Turn the HI TEMP dial to select feature *8*
3. Push the Test/Settings Button to turn Low Water Cut-Off *ON* or *OFF*
4. Reset LO TEMP and HI TEMP settings to desired temperatures (see page 7)

### Restore Factory Default Settings

#### To restore all features to the factory default settings (see following chart for default settings)

1. Turn the LO TEMP dial to access the Program Mode – indicated in the display as *PR*
2. Turn the HI TEMP dial to select feature *DEF*
3. Push the Test/Settings Button to *4* to reset all features to the default settings.
4. Reset LO TEMP and HI TEMP settings to desired temperatures (see page 7)

Dial Setting	Feature	Options	Description	Default Setting
<i>1</i>	Thermal Pre-Purge	<i>OFF</i> <i>ON</i>	Purge Inactive Purge Active	<i>OFF</i>
<i>2</i>	Fahrenheit or Celsius	<i>F</i> <i>C</i>	Degrees Fahrenheit Degrees Celsius	<i>F</i>
<i>3</i>	LWCO Manual or Automatic Reset	<i>A</i> <i>B</i>	Automatic Reset Manual Reset	<i>A</i>
<i>4</i>	Circulator Options	<i>A</i> <i>B</i> <i>C</i>	Circulator operation on TT call only Circulator operation on ZC/ZR call only Circulator operation on call from either	<i>A</i>
<i>5</i>	<i>Circulator Hold Off</i>	<i>ON</i> <i>OFF</i>	Circulator Hold Off – Active Circulator Hold Off – Inactive	<i>ON</i>
<i>6</i>	<i>Not available on this control</i>			
<i>7</i>	<i>Not available on this control</i>			
<i>8</i>	Low Water Cut-Off Function	<i>ON</i> <i>OFF</i>	Low Water Cut-Off ON Low Water Cut-Off OFF	<i>ON</i>
<i>DEF</i>	Restore Factory Defaults	<i>4</i> <i>n</i>	Restore Defaults Do Not Restore Defaults	<i>n</i>

NOTE: If the HydroStat is factory-equipped on a boiler, some options may be set differently from the default settings.

SEE PAGE 7 FOR ADDITIONAL SETTINGS

## LED LEGEND and TEST/SETTINGS BUTTON

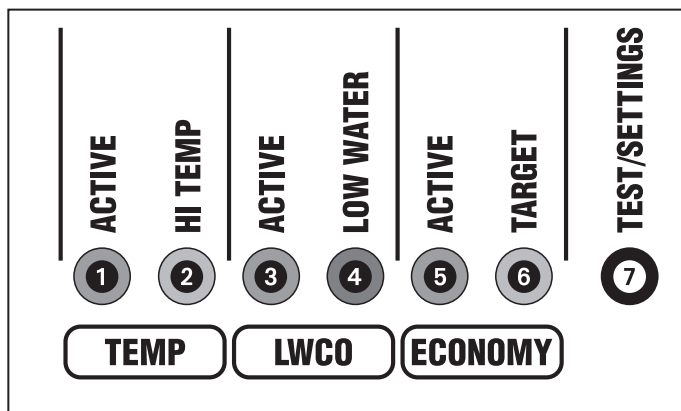

**1 TEMP ACTIVE** Indicates that the Fuel Smart HydroStat control is powered and that the temperature function is active.

**2 TEMP HI TEMP** Illuminates when the boiler water temperature reaches the high limit setting. It will remain lit until the water temperature falls 10°. The Fuel Smart HydroStat prevents burner operation while this LED is on. See Differential explanation on page 7.

**3 LWCO ACTIVE** Indicates that the low water cut-off (LWCO) function of the Fuel Smart HydroStat is active. When the control is installed with a Hydrolevel Electro-Well™, this LED will be on at all times when the control is powered. **IMPORTANT:** If the control is installed with a well other than the Electro-Well™, this LED will not illuminate indicating that the control is not providing low water cut-off functionality.

**4 LWCO LOW WATER** Indicates that the boiler is in a low water condition. The HydroStat control will prevent burner operation during this condition. If the LOW WATER light is blinking, the control has been programmed to provide lock-out protection in the event a low water condition is detected (see Manual Reset Low Water Cut-Off on page 9). Pressing the TEST/SETTINGS button will reset the control.

**IMPORTANT:** The system must be checked by a qualified heating professional prior to resuming operation.

**WARNING: ALLOW THE BOILER TO FULLY COOL BEFORE ADDING WATER.**

**5 ECONOMY ACTIVE** Indicates that the Thermal Targeting function is active and the Fuel Smart HydroStat will reduce boiler temperature to conserve fuel. The Economy feature is activated using the ECONOMY dial. (See “How Thermal Targeting Works” on page 8 for more information).

**6 ECONOMY TARGET** When the Economy feature is active, the Fuel Smart HydroStat continually sets target

temperatures below the high limit setting to maximize fuel efficiency. When the boiler water reaches the target temperature, the LED illuminates and the burner will shut down. The boiler water will continue to circulate and heat the house as long as the thermostat call continues. The LED will stay lit until the boiler temperature drops below the differential set point at which point the boiler will be allowed to fire again. See Differential explanation on page 7.

**NOTE:** This LED illuminates regularly during normal boiler operation.

### 7 TEST/SETTINGS Button

**To Test Low Water Cut-Off:** Press and hold the Test/Settings button for 5 seconds. The display will read LCO.

LWCO TEST LCO

The red Low Water light should illuminate and the burner circuit (B1 and B2) should de-energize. **NOTE:** The control must be installed with a Hydrolevel Electro-Well™ for low water cut-off functionality (see page 2 for more details).

**To View Current Settings:** Press and release the Test/Settings Button in short intervals to sequentially display the following settings:

HIGH LIMIT SETTING HL

LOW LIMIT SETTING LL

ECONOMY SETTING ECO

CURRENT TARGET TEMPERATURE 000

The display will return to boiler temperature (default) if Test/Settings Button is not pressed for 5 seconds.

## MAINTENANCE

Remove the Electro-Well™ from the heating system every five years and clean any scale or sediment deposits from all parts that are exposed to the boiler water. After cleaning, reinstall the well using pipe sealing compound. **Teflon tape is not recommended.**

## TROUBLESHOOTING

<b>Burner Will Not Fire</b>	See Flow Chart 1, page 13
<b>Burner Will Not Shut Down</b>	See Flow Chart 2, page 14
<b>Temperature Display Exceeds High Limit Setting</b>	Under normal operation, boiler temperature will continue to rise after the control shuts off the burner. This condition, known as “thermal stacking”, results from hot boiler surfaces continuing to release heat into the boiler water.
<b>No or Insufficient Domestic Hot Water</b>	For boilers equipped with a tankless coil, make sure the low limit setting on the HydroStat is set properly. <b>NOTE:</b> If the low limit setting is dialed fully counter clockwise, it will shut off the low temperature maintenance feature and will function as a cold start control. If installed with an indirect water heater, check that the Zone/Indirect Switch is set in the Indirect (I) position. Verify that the end switch in the relay box controlling the indirect water heater is connected to the <b>ZC-ZR</b> terminals. This will ensure that the domestic water calls are prioritized. (see “Heating and Indirect Water Heater” on page 4-6).
<b>Low Water Light (Red LED) is On or Blinking</b>	 <p><b>WARNING:</b> A low water condition is a serious and potentially dangerous condition. Do not attempt to add water to a hot boiler. Allow the boiler to fully cool before adding water.</p> <p><b>When Installed on an Electro-Well™</b></p> <p>When the LOW WATER light is on, this indicates that the control is not detecting water in the boiler. When the LOW WATER light is blinking, this indicates that the control has been programmed to provide low water lock-out protection and is currently locked out (see Manual Reset Low Water Cut-Off on page 9). Pressing the TEST/SETTINGS button after the low water condition is resolved will reset the lock-out condition.</p> <ol style="list-style-type: none"> <li>1. If the light is on and the heating system is filled with water, pull the sensor out of the well and inspect it. Make sure that the metal clip is protruding enough to come in contact with the inside of the well tube. Check that the well does not have excessive build-up of heat transfer grease that may interfere with the clip contacting the well.</li> <li>2. Remove well and examine for excessive residue build-up. Clean and re-install.</li> </ol> <p><b>When Installed on a Standard Immersion Well</b></p> <p>If either LWCO LED lights are illuminated and the control is installed on a standard immersion well, this is a false reading caused by a loss of continuity between the sensor and the inside of the well tube. It is recommended when the control is installed on a standard immersion well, the LWCO Function be turned off (see page 10 for details).</p>
<b>Boiler Will Not Maintain Low Limit Temperature</b>	Check for overlapping high temperature setting. If the high limit setting is set below the low limit setting, the control will default to the high limit setting and the corresponding high limit differential setting.
<b>House Will Not Get or Stay Warm</b>	<ol style="list-style-type: none"> <li>1. Check for air-bound radiators.</li> <li>2. Check thermostat settings including heat anticipator settings (common on non-digital thermostats).</li> <li>3. Check the Economy setting. The Economy feature, much like outdoor reset controls, lowers average boiler temperature and can slow or, in some cases, prevent the house from coming up to temperature. Move to a lower setting (see “Setting the Economy Feature” on page 7).</li> </ol>
<b>Circulator Contacts C1 and C2 Not Energized on Call for Heat</b>	Check to see that boiler water is at or above 125°F. On a call for heat, the control will not permit the circulator to operate if the boiler water temperature is below 125°F (see “Circulator Hold Off” on page 9).
<b>All LED Lights and Temp Display are Blinking</b>	If the LED lights and the temp display are blinking alternately, this indicates the control has sensed a boiler temperature of 250°F. When this occurs, the control pulses the burner relay and then shuts down and locks-out the burner. The system should be analyzed to determine the cause of the overheating condition. Check that the sensor is inserted all the way into the well so it can accurately sense the temperature of the boiler water. Check the load on the burner contacts: If the load exceeds the 7.4 Amp rating, the contacts may have welded. Correct the overloading condition and replace the control before reenergizing the system. If the load on the contacts is below the rating, check system wiring and operation as well as the control’s high limit setting. If the cause of the overheating is found and the system is deemed safe, the control can be reset by removing power from the control and then repowering while simultaneously pressing the Test/Settings button on the top of the control. If the cause of the overheating condition is not determined, the control should be replaced.

# Troubleshooting Flow Chart 1 – Burner Will Not Fire

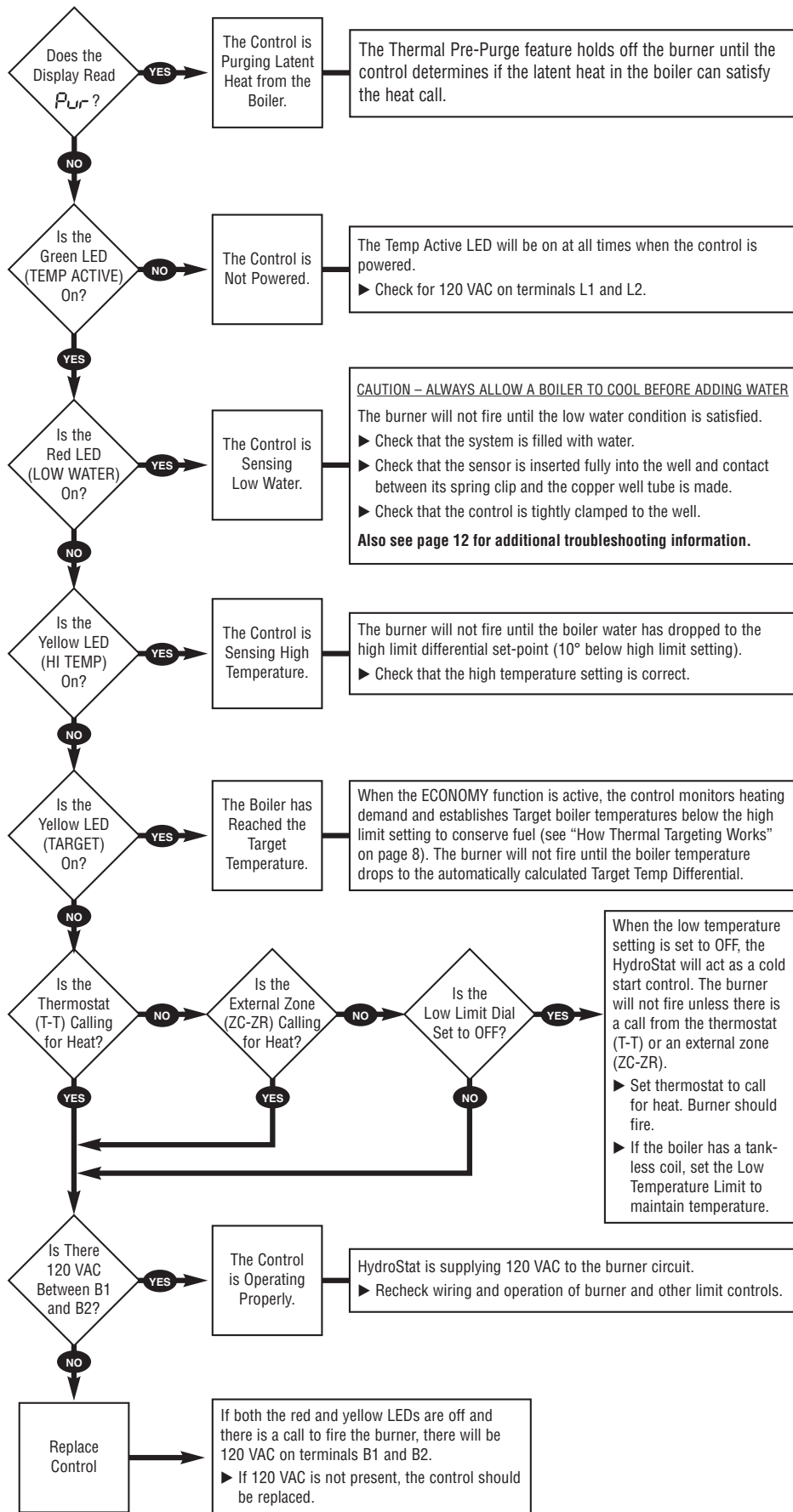

# Troubleshooting Flow Chart 2 – Burner Will Not Shut Down

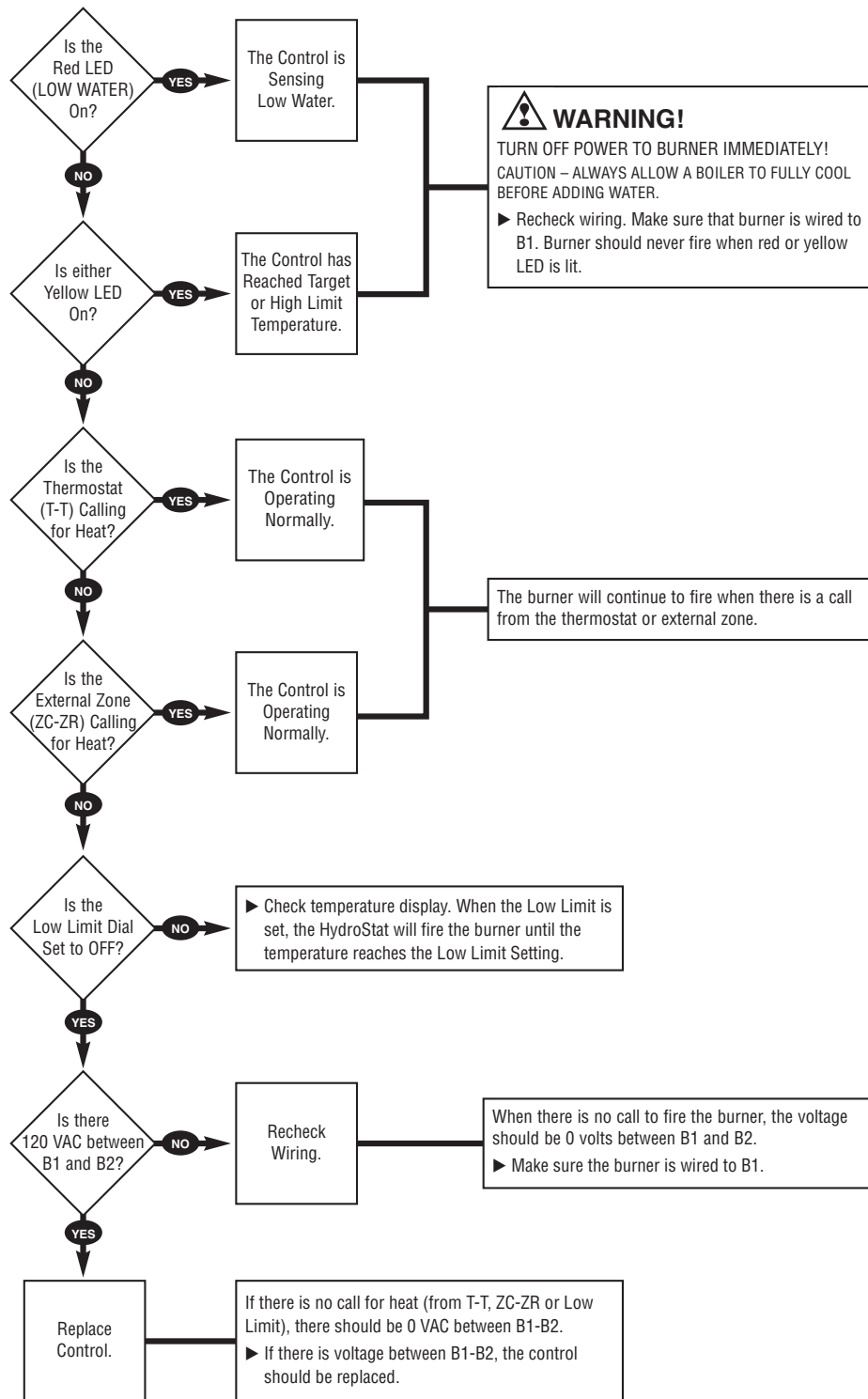

## Fuel Smart HydroStat installed with Electro-Well™

When installed with the Hydrolevel Electro-Well™, Fuel Smart HydroStat will provide *both* temperature and low water cut-off functionality. If the control was supplied by the boiler manufacturer, it was installed with an Electro-Well™. The Electro-Well™ is available separately for field installations.

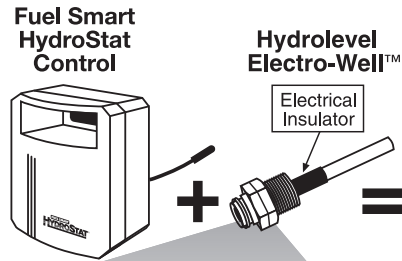

**PROVIDES TEMPERATURE, ECONOMY AND LOW WATER CUT-OFF FUNCTIONALITY**

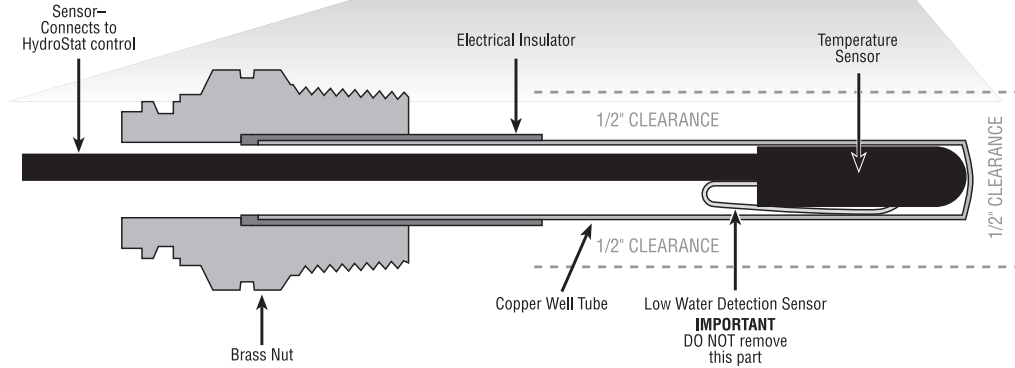

**IMPORTANT:** For proper operation of the low water cut-off function, there must be a minimum of 1/2" clearance between the copper well tube and any surface within the boiler.

## Electro-Well™ Models

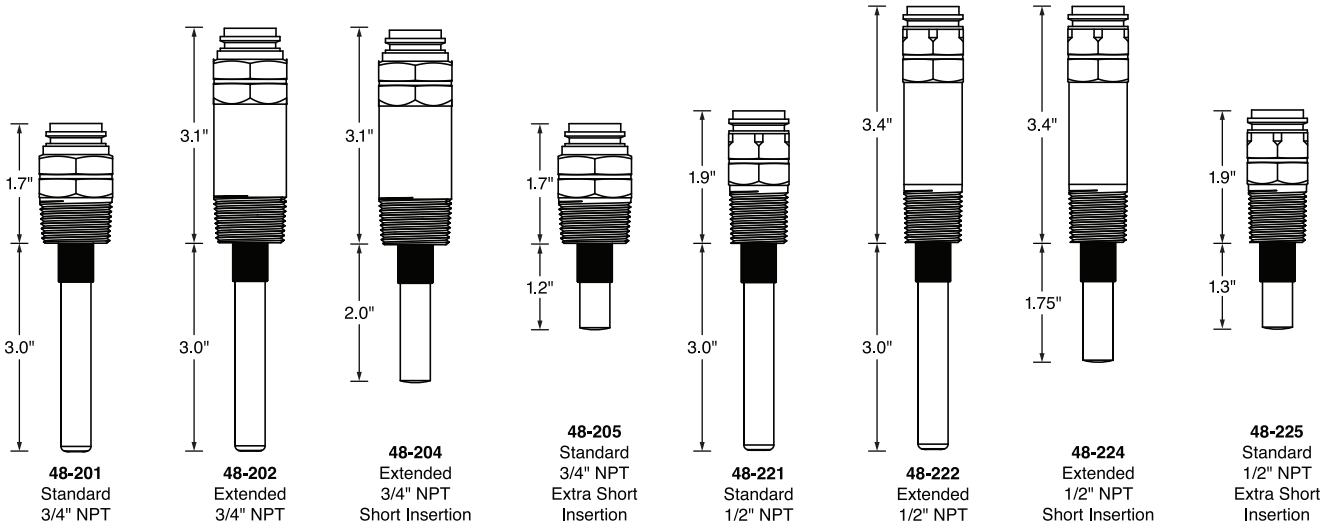



## OUTDOOR SENSOR KIT

Hydrolevel's optional Outdoor Sensor Kit automatically activates outdoor reset functionality and warm weather shutdown capability when plugged in to the Fuel Smart HydroStat control. This low cost, easy to install kit is available separately at Hydrolevel distributors.

Part No.	Description
48-140	Model OS-100 Outdoor Sensor Kit

## REMOTE MOUNTING KITS

Part No.	Description	Part No.	Description
48-101	HydroStat Remote Mount Kit with 24" sensor	48-103	HydroStat Remote Mount Kit with 10' sensor
48-102	HydroStat Remote Mount Kit with 48" sensor	48-104	HydroStat Remote Mount Kit with 20' sensor
		48-121	HydroStat Pipe Mounting Kit with 48" sensor

## DIMENSIONS

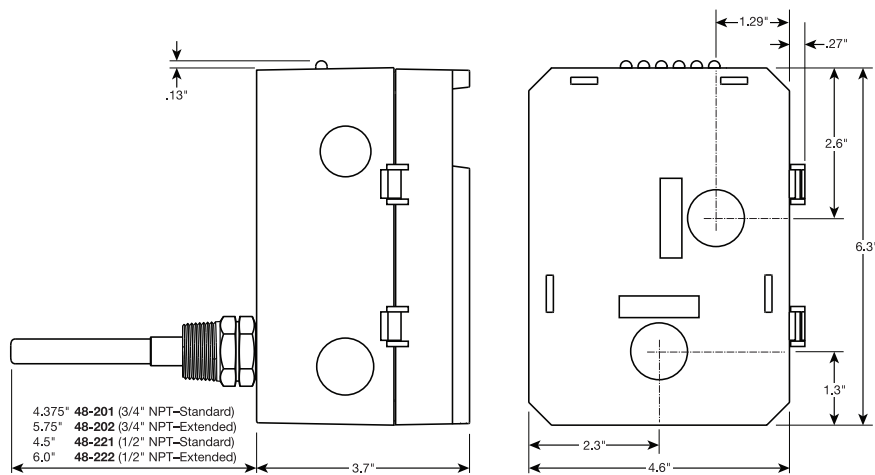

## SPECIFICATIONS FUEL SMART HYDROSTAT MODEL 3250-Plus

Input voltage	120 VAC, 60 HZ
Burner contacts	7.4 FLA, 44.4 LRA@120 VAC
Circulator contacts	5.8 FLA, 34.8 LRA@120 VAC
Operating range – low limit	Off or 110°F (43°C) - 200°F (93°C)
Operating range – high limit	100°F (38°C) - 220°F (104°C)
Operating range – differentials	Automatic
Thermostat heat anticipator setting	0.2A



### LIMITED MANUFACTURER'S WARRANTY

We warrant products manufactured by Hydrolevel Company to be free from defects in material and workmanship for a period of two years from the date of manufacture or one year from the date of installation, whichever occurs first. In the event of any claim under this warranty or otherwise with respect to our products which is made within such period, we will, at our option, repair or replace such products or refund the purchase price paid to us by you for such products. In no event shall Hydrolevel Company

be liable for any other loss or damage, whether direct, indirect, incidental or consequential. This warranty is your EXCLUSIVE remedy and shall be IN PLACE OF any other warranty or guarantee, express or implied, including, without limitation, any warranty of MERCHANTABILITY or fitness for a particular purpose. This warranty may not be assigned or transferred and any unauthorized transfer or assignment thereof shall be void and of no force or effect.