

HEAT EXCHANGER RETROFIT KIT INSTRUCTIONS

**Kit #'s 550003050, 550003051,
550003052, 550003053, 550003054**

Kit installation shall be completed by qualified agency.

Original heat exchanger for boiler is no longer available, it is replaced by new block ("B"). Install parts listed to maintain boiler operation.

⚠ WARNING

Fire, explosion, asphyxiation and electrical shock hazard. Improper installation could result in death or serious injury. Read this instruction and understand all requirements, including requirements of authority having jurisdiction, before beginning installation. Installation not complete until appliance operation verified per Installation, Operation & Maintenance Manual provided with boiler.

⚠ WARNING

Asphyxiation hazard. Do not replace flueway baffles in replacement heat exchanger (B). Replacement of flueway baffles could result in death or serious injury.

Follow instructions TO TURN OFF GAS TO APPLIANCE found on Operating Instructions label on boiler or in Installation, Operation & Maintenance Manual. Verify all electrical power to boiler is turned off.

DO NOT replace flueway baffles in replacement heat exchanger ("B"). See Figure 6.

2 and 3 section models **DO NOT** require use of replacement parts. See Table 1.

⚠ WARNING

Electrical shock hazard. Turn OFF electrical power supply at service panel.

- Attach included label to side of boiler near nameplate for future reference.
- New Label is provided to indicate heat exchanger model change to "B".
- Bracket is provided to mount rollout switch in new location on models indicated in Table 1 only. Rollout switch has not changed only relocated. See Figure 2 page 2, and Template page 7.
- Spark pilot wire shield applies to units using "B" series block only. See Figure 5 page 3, and Template page 5.
- Pilot bracket assembly is one piece welded assembly, includes L-side shield.

⚠ WARNING

Explosion hazard. Lockout/tagout gas supply at gas meter or other location external to boiler.

⚠ WARNING

Burn hazard. Verify heat exchanger has cooled or use appropriate personal protection equipment before removing heat exchanger.

Table 1 - Changes to DVB, ODVB, CDVB

Kit Numbers	550003050	550003051		550003052	550003053	550003054	
Input (Mbh)	50	75	100	125	150	175	200
Sections	2	3		4		5	
Label				✓	✓	✓	✓
Replace Pilot and Gas Valve Wire Routing				✓	✓	✓	✓
Relocate Flame Rollout Switch				✓	✓		
Replace Burner Door					✓	✓	✓
Pilot Bracket Assembly				✓	✓	✓	✓
Remove Flue Baffles	✓	✓	✓	✓	✓	✓	✓

HEAT EXCHANGER REPLACEMENT KIT INSTRUCTIONS

⚠ WARNING

Asphyxiation hazard. Do not replace flueway baffles in replacement heat exchanger (B). Failure to follow these instructions could result in death or serious injury.

1. **DO NOT replace flueway baffles in replacement heat exchanger ("B"). See Figure 6.**

⚠ WARNING

Asphyxiation hazard. Replace burner door with replacement heat exchanger where provided. Discard original burner door. Failure to follow these instructions could result in death or serious injury.

2. Replace Burner Door. See Figure 1.
 - Replacement Burner Door is required on sizes indicated in Table 1.
 - Discard original burner door to prevent reuse.

Figure 1 - Replacement Burner Door with Tabs

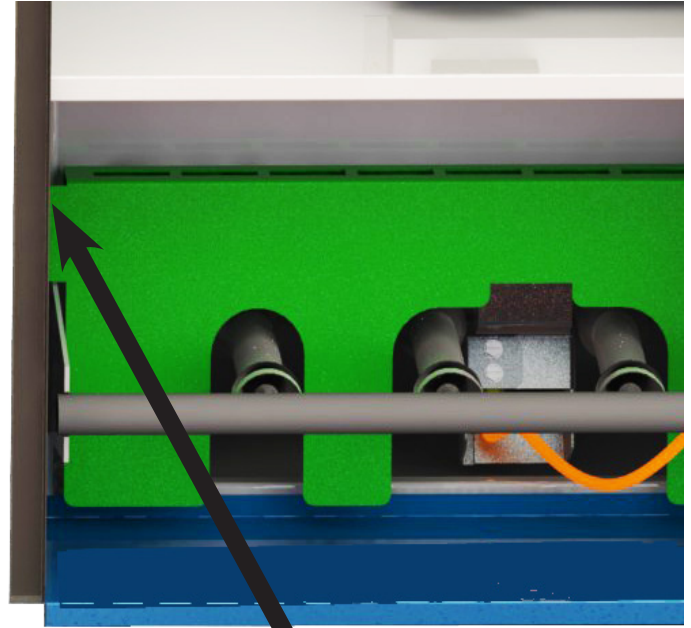

Burner door tabs are positioned on top of manifold bracket, 2 sides.

3. Relocated Flame Rollout Switch requires relocation with burner door replacement, reducing potential for nuisance shut downs. See Figure 2.
 - Label all wires for reference before disassembly.

Figure 2 - Replacement Flame Rollout Switch Bracket

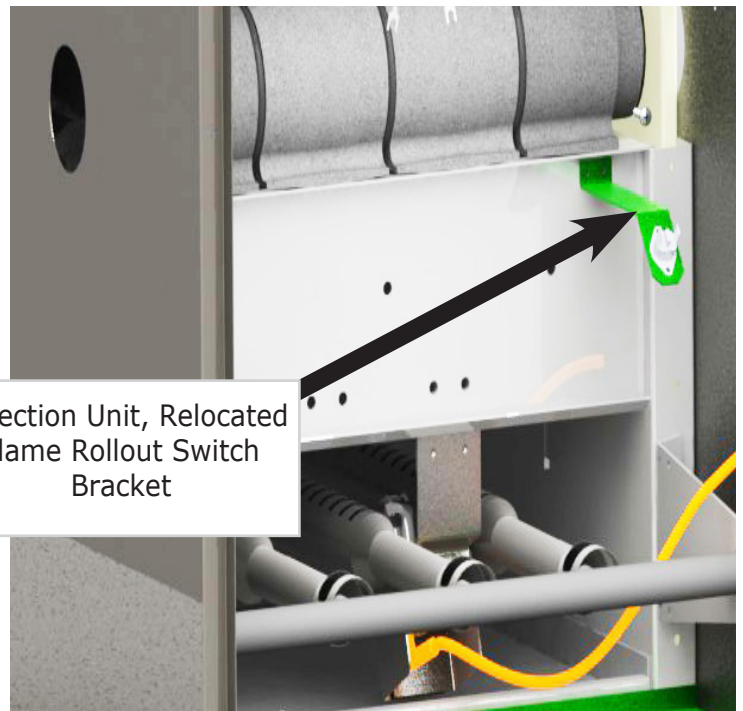

4 Section Unit, Relocated Flame Rollout Switch Bracket

HEAT EXCHANGER REPLACEMENT KIT INSTRUCTIONS

Figure 3 - Pilot Shield Bracket

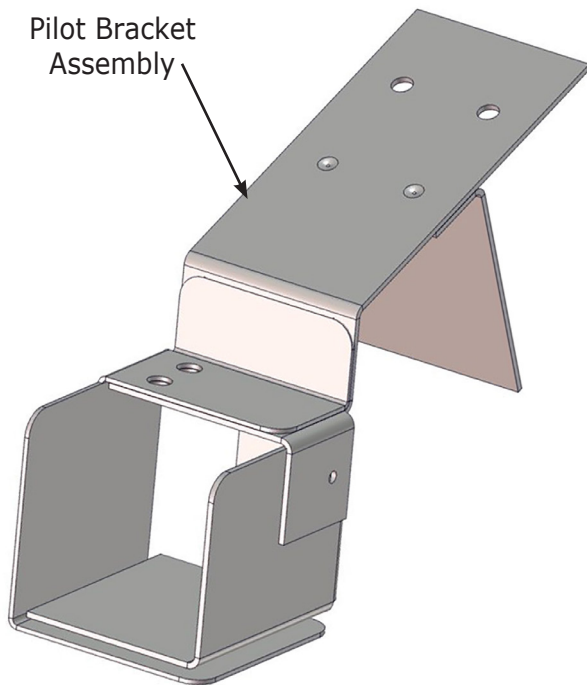

4. Pilot Bracket Assembly on spark Ignition models is now a one piece welded assembly which includes the Pilot Shield Bracket. Use original spark ignitor pilot assembly and mounting screws (5). Assemble as shown in Figure 4.
5. Relocation of gas valve and spark wiring to reduce potential for wire chafing is required on sizes indicated in Table 1. See Figure 5.
 - Templates are provided for relocation of wiring. See pages 5 and 7.

Figure 4 - Pilot Spark Ignitor Mounting

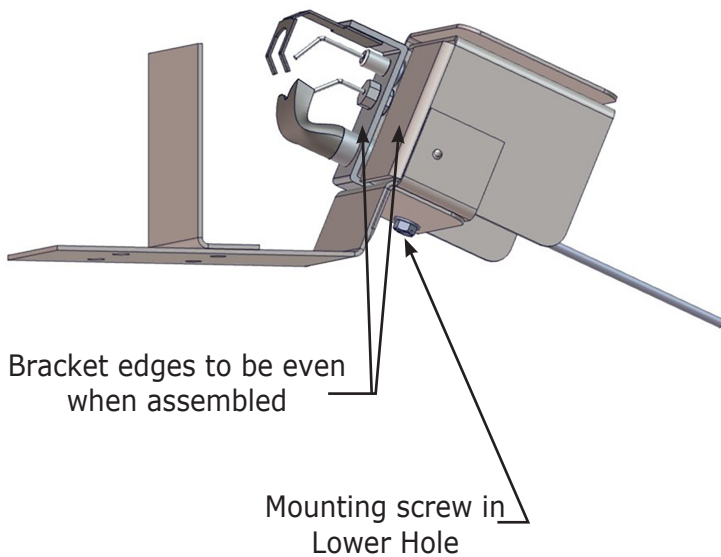
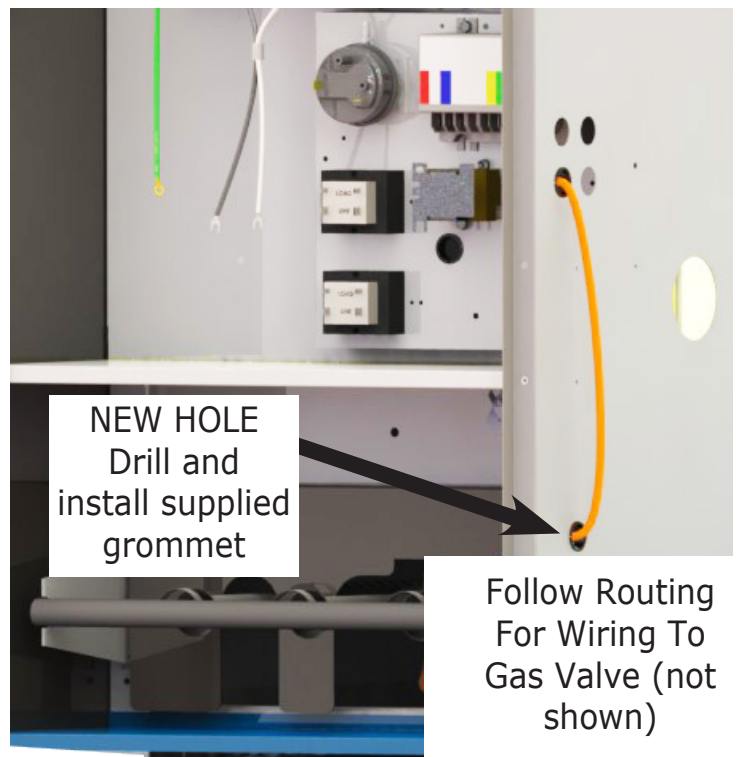
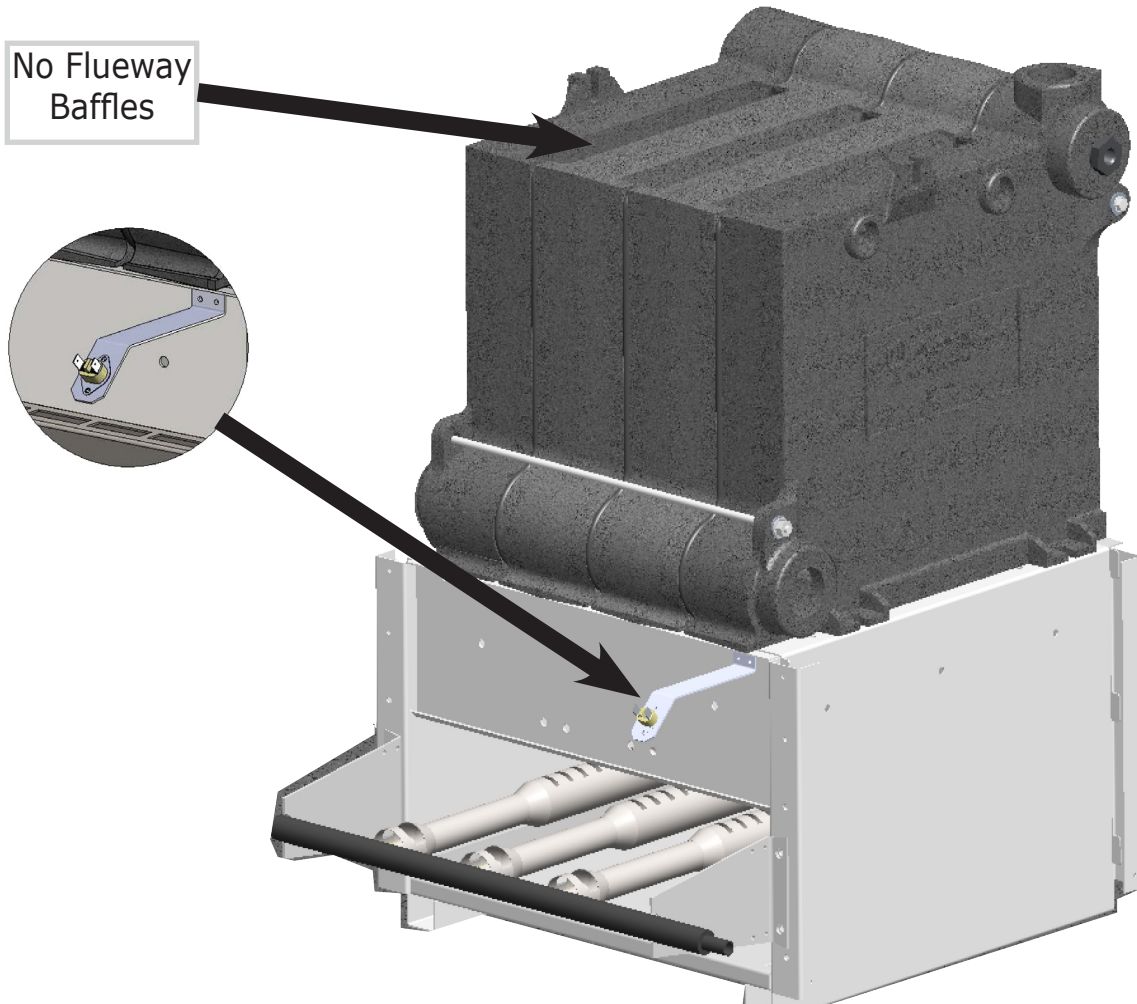

Figure 5 - Gas Valve and Spark Wiring Relocation



HEAT EXCHANGER REPLACEMENT KIT INSTRUCTIONS

Figure 6 - Replacement Heat Exchanger



HEAT EXCHANGER REPLACEMENT KITS - PARTS LISTING					
Sections	2	3	4		5
Input (MbH)	50	75-100	125	150	175-200
Kit #	550003050	550003051	550003052	550003053	550003054
Heat Exchanger Block	YES	YES	YES	YES	YES
Rollout Switch Bracket	-	-	-	109008517	-
Screws 1/4-20 x 1/2 Self Tap	-	-	YES (2)	YES (2)	YES (2)
Pilot Shield (Spark units only)	-	-	YES	YES	YES
Screws Slotted 8-18 x 1/2	-	-	-	YES (2)	-
Burner Door	-	-	-	109009073	109009074
Grommet			YES	YES	YES
Template, Right Hand Panel			Included in Instructions		
Template, Base			Included in Instructions		
Label	YES	YES	YES	YES	YES
Instructions	240011042	240011042	240011042	240011042	240011042
NOTE: Items denoted as "YES" are not sold separately.					

JACKET PANEL TEMPLATE (ALL SIZES)

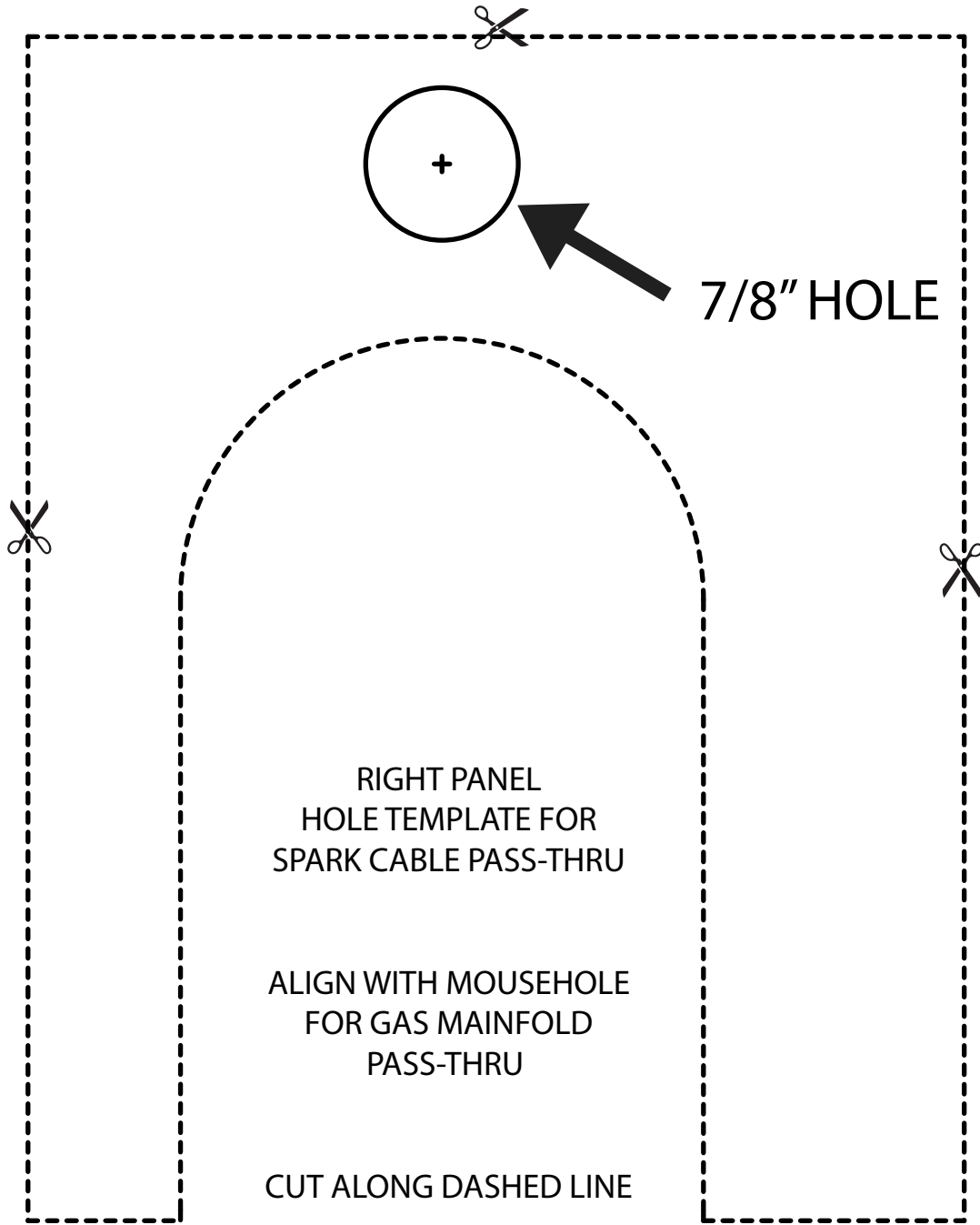

THIS PAGE INTENTIONALLY LEFT BLANK

4 SECTION (150 SIZE ONLY) ROLLOUT BRACKET RELOCATION TEMPLATE

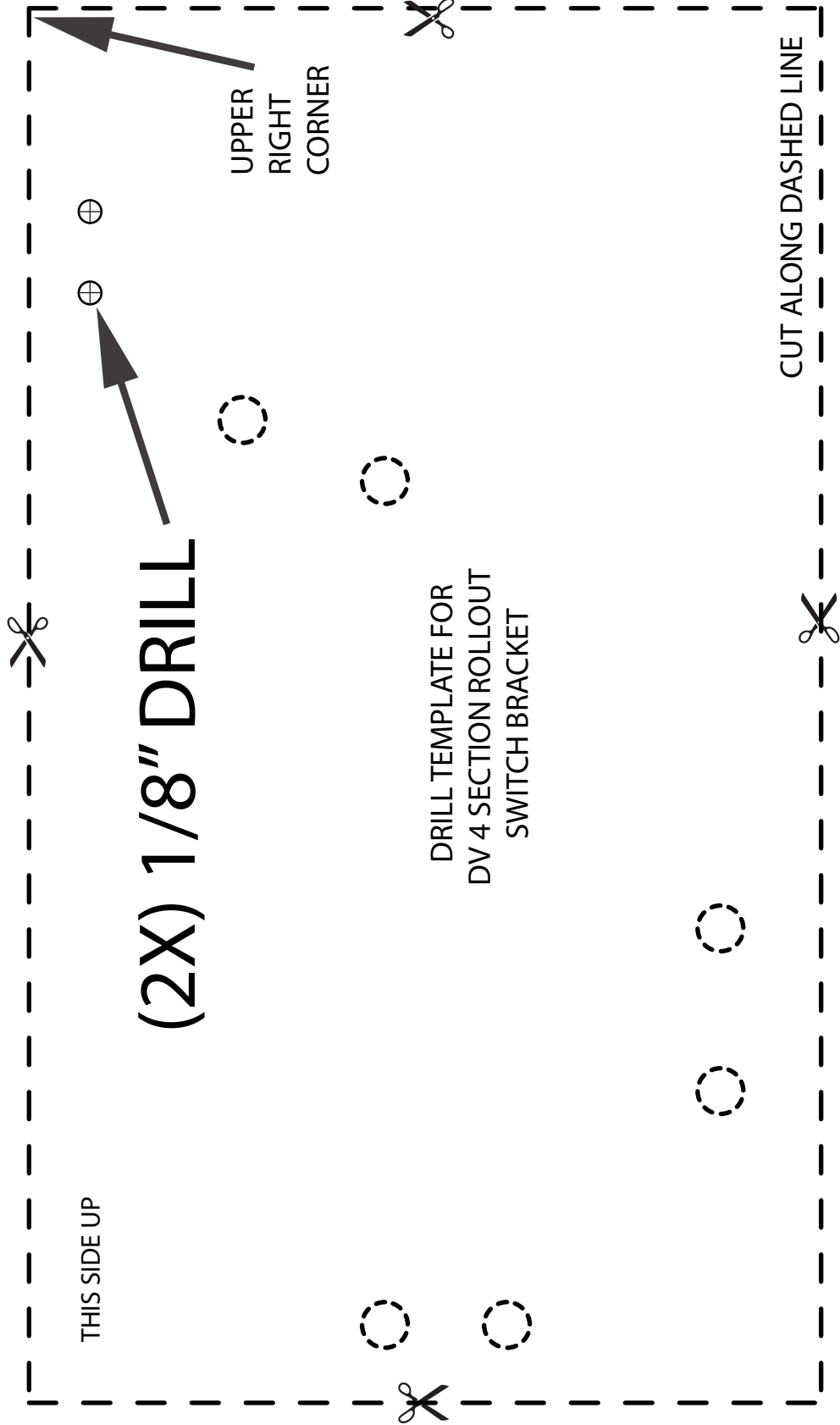

THIS PAGE INTENTIONALLY LEFT BLANK