

# CONDENSATE TRAP KIT INSTRUCTIONS

## 399 Kit # 550003100

Kit installation shall be completed by qualified agency.

### **⚠ WARNING**

Fire, explosion, asphyxiation and electrical shock hazard. Improper installation could result in death or serious injury. Read this instruction and understand all requirements, including requirements of authority having jurisdiction, before beginning installation. Installation not complete until appliance operation verified per Installation, Operation & Maintenance Manual provided with boiler.

### **Condensate Trap kit:**

Tools required: Spring hose clamp pliers

1. Follow instructions TO TURN OFF GAS TO APPLIANCE found on Operating Instructions label on boiler or in Installation, Operation & Maintenance Manual. Verify all electrical power to boiler is turned off.

### **⚠ WARNING**

Electrical shock hazard. Turn OFF electrical power supply at service panel.

2. Remove front jacket panel(s).

### **⚠ WARNING**

Burn hazard. Verify heat exchanger has cooled or use appropriate personal protection equipment.

3. Inspect combustion chamber through sight glass. Verify flame is not present. See figures 1 & 2.
4. Expand flue collector spring tension clip using hose clamp pliers. Disconnect condensate trap from condensate collector. See figure 3.
5. Expand chassis spring tension clip. Disconnect trap from barb coupling.
6. Go to step 10 if only replacing condensate trap.
7. Un-thread barbed coupling from condensate piping.
8. Pull barbed coupling through grommet. Remove grommet from chassis.
9. Install new grommet in chassis. Insert barbed coupling through grommet.
10. Apply Teflon tape to barbed coupling threads. Thread barbed coupling into condensate piping.
11. Expand spring tension clip and place over end of condensate trap. Insert condensate trap onto barbed coupling. Secure over clip.
12. Expand spring tension spring tension clip and place over end of condensate trap. Insert condensate trap onto condensate collector barb. Secure with spring tension clip.

**Figure 1 - Sight Glass**

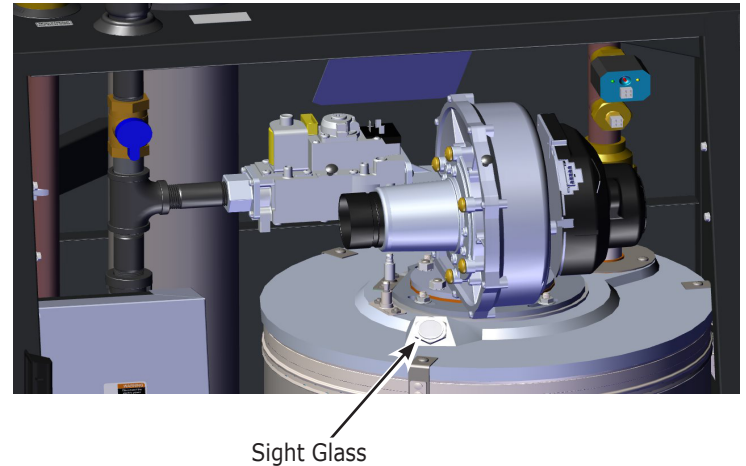

**Figure 2 - Condensate Drain Assembly**

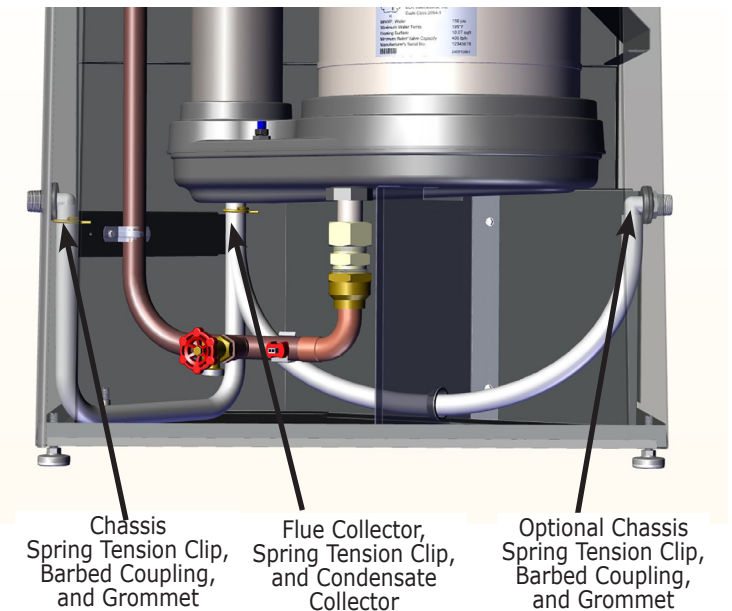

## NOTICE

IMPORTANT: Condensate trap must be manually filled with water at initial start up.

13. Resume operation using OPERATING INSTRUCTIONS found on Operating Instructions label on boiler or in Installation, Operation & Maintenance Manual.
14. Verify proper operation by following START UP PROCEDURE in Installation, Operation & Maintenance Manual.
15. Install front jacket panel.

## **PARTS LIST**

<b>399 Condensate Trap Kit # 550003100</b>		
DESCRIPTION	PART #	QTY
Spring tension Clip, 1-1/8"	-	2
Condensate Trap	-	1
Grommet, 1.75 x 1.00	-	1
Elbow, Barbed 3/4"	-	1
Instructions	2400011191	1

Check our website frequently for updates: [www.ecrinternational.com](http://www.ecrinternational.com)