

399 WIRE HARNESS KIT

INSTRUCTIONS Kit #550003101

Kit installation shall be completed by qualified agency.

⚠ WARNING

Fire, explosion, asphyxiation and electrical shock hazard. Improper installation could result in death or serious injury. Read this instruction and understand all requirements, including requirements of authority having jurisdiction, before beginning installation. Installation not complete until appliance operation verified per Installation, Operation & Maintenance Manual provided with boiler.

Wire Harness Removal:

1. Tools required:
 - Needle nose pliers
 - Small (No. 1) phillips screwdriver
 - Small wire ties
 - 11/32" Nut Driver, Wrench or Socket
 - 1/4" Nut Driver
 - Side cutters
2. Follow instructions to TURN OFF GAS TO APPLIANCE found on Operation Instructions label on boiler or in Installation, Operation & Maintenance Manual. Verify all electrical power to boiler is turned off.

WARNING

Electric shock hazard. Turn OFF electrical power supply at service panel.

3. Remove jacket panel.

⚠ WARNING

Burn hazard. Verify heat exchanger has cooled or use appropriate personal protection equipment.

4. Inspect combustion chamber through sight glass. Verify flame is not present. See figure 1.

Figure 1 - Sight Glass

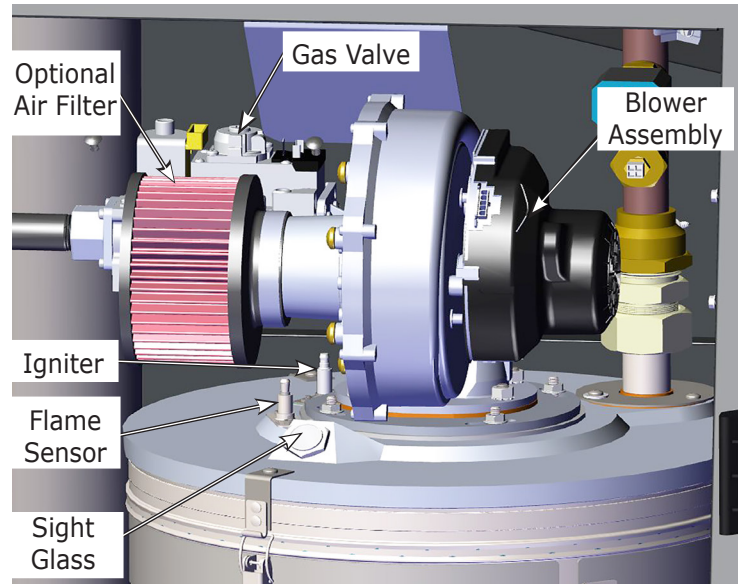

WIRE HARNESS KIT INSTRUCTIONS

5. Disconnect High Voltage Terminal Block
 - Remove retaining screw from high voltage terminal box, remove cover.
 - Remove two (2) screws holding high voltage terminal strip. Lift strip up and out. Leave field wiring attached to strip. Disconnect boiler connections from rear terminals.
 - Disconnect low voltage terminal blocks.
 - Disconnect field wiring from low voltage terminal blocks. Mark wires before removal.
 - Remove low voltage terminal blocks from control panel.
6. Disconnect wire harness from return water sensor.
7. Disconnect wire harness from control module.
8. Disconnect wire harness from relays (four (4) places).
9. Disconnect flame sensor cable from flame sensor. Remove right-side 8-32 hex nut using 11/32" nut driver, wrench or socket. Disconnect ground wire from stud.
10. Disconnect two (2) wire harnesses from blower motor, high temperature supply switch, low water cutoff, and gas valve.
11. Disconnect plug to user interface. If replacing harness to user interface, open user interface by pushing on the bottom tab and lift up on the display. Unscrew (2) two wires on the display base.
12. Disconnect ground screw wire from control panel and chassis.
13. Disconnect wire harness from flue sensor.
14. Remove wire harness from boiler.

Figure 2 - User Interface

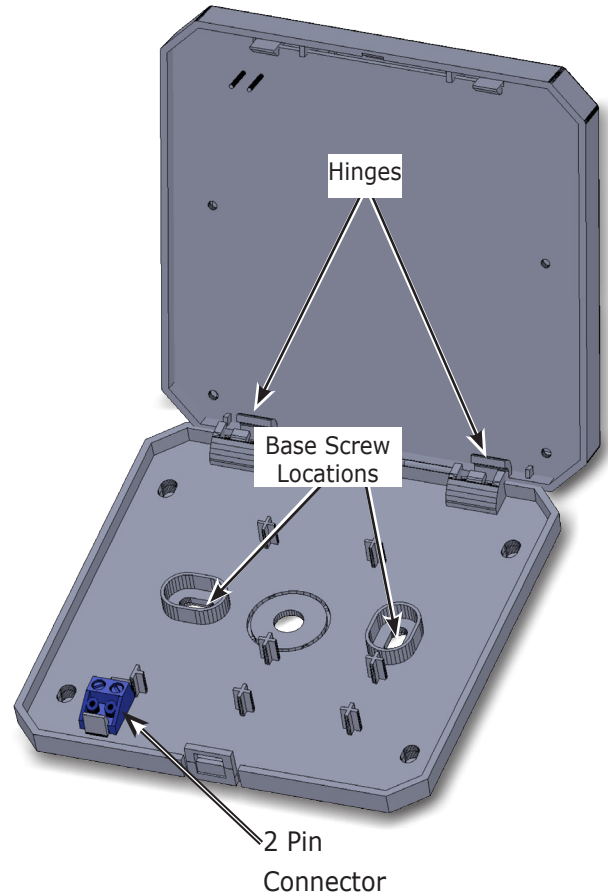

WIRE HARNESS KIT INSTRUCTIONS

Figure 3 - 050/075/100 Model Shown

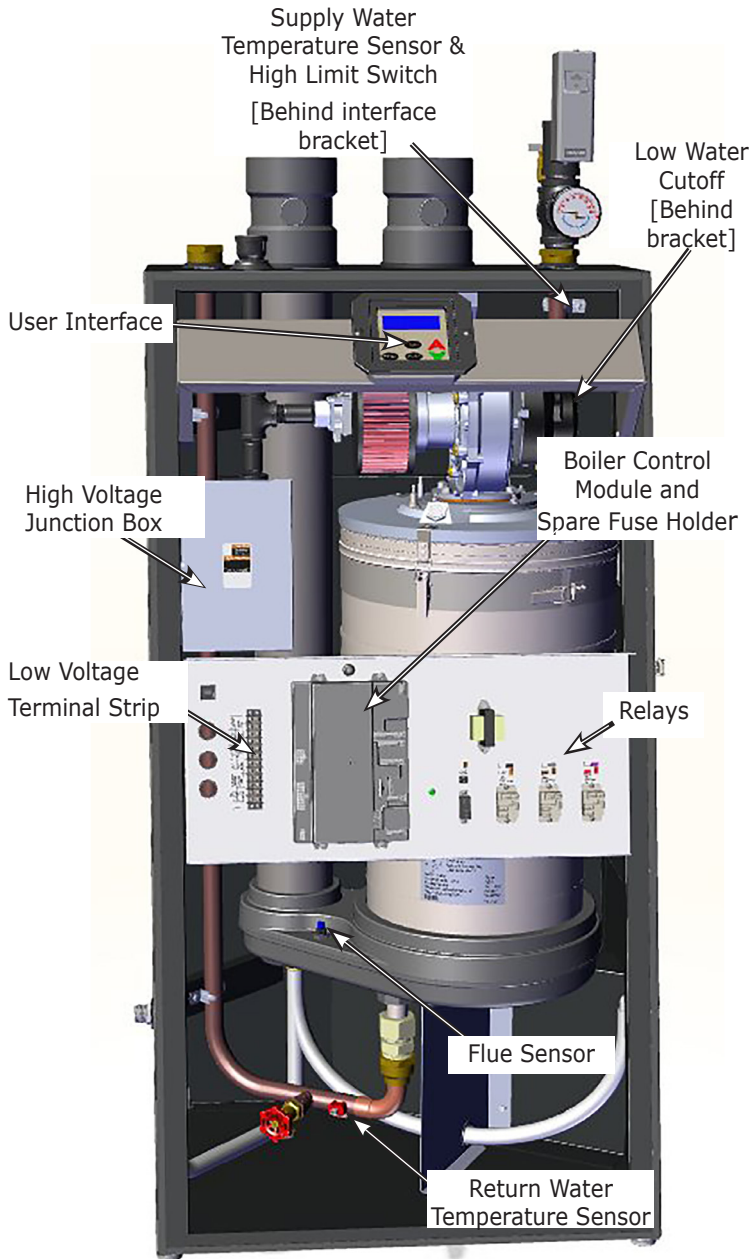

Wire Harness Replacement:

1. Connect wire harness to control module.

NOTICE

Control module has two (2) 4-wire connectors (J2 and J4). Wires into plugs are labeled to assist in connection to proper jack.

2. Connect wire harness to pump relays. Refer to pump relay labels and wire diagram for proper installation.
3. Attach one (1) green ground wire to control panel. Secure with green ground screw. Attach second green ground wire to chassis with green ground screw.
4. If removed, insert user interface plug into mounting plate, snap into place. Connect user interface plug.
5. Insert harness into boiler and secure by pushing cable tie barbs into place.
6. Connect flame sensor plug. Attach ground wire to right stud of flame sensor and secure with nut. Do not over-tighten.
7. Connect wire harness to high temperature sensor supply switch and low water cutoff.
8. Connect wire harness to blower (2 places).
9. Install Gas Valve harness. Attach gas valve harness to gas valve. Secure with integral screw.
10. Connect high voltage leads to high voltage terminal strip. Secure high voltage terminal strip with two (2) screws.
11. Connect wire harness to return water temperature sensor.
12. Connect low voltage wires to low voltage terminal block.
13. Install low voltage terminal blocks to control panel with clips provided.
14. Connect wire harness to flue sensor.
15. Attach high voltage terminal box cover. Secure with screw.
16. Install jacket.
17. Resume operation using OPERATING INSTRUCTIONS found on Operating Instructions label on boiler or in Installation, Operation & Maintenance Manual.
18. Verify proper operation by following START UP PROCEDURE in Installation, Operation & Maintenance Manual.

PARTS LIST

399 Wire Harness Kit #550003101		
Main Boiler 120V Wiring Assembly Harness to High Voltage Terminal Block 399	-	1
24V Wire Harness, From Boiler Interface Module to Low Voltage Terminal Block	-	1
Screw, 6x3/8, Type B HPH, SZN	-	4
Screw, 8-32x5/16, Self Tapping, Ground, Green	-	1
Instructions	240011192	1

Check our website frequently for updates: www.ecrinternational.com