

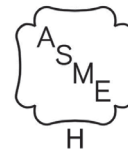

Models
MGB-50J
MGB-75J
MGB-100J
MGB-125J
MGB-150J
MGB-170J
MGB-200J

MGB
CAST IRON GAS FIRED BOILERS
FOR FORCED HOT WATER
with Honeywell Control

**INSTALLATION, OPERATION
& MAINTENANCE MANUAL**

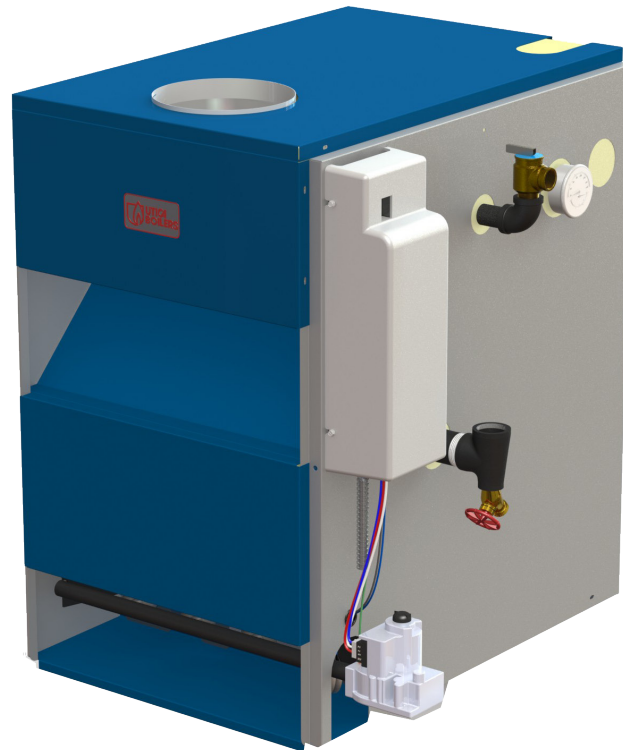

C.S.A. Certified
For Natural Gas
Or Propane

Tested For 100 psi.
ASME
Working Pressure



ECR international
EST. 1928
A Family of Heating & Cooling Brands.

Manufactured by:
ECR International, Inc.
2201 Dwyer Avenue, Utica NY 13501
web site: www.ecrinternational.com

P/N 240011584, Rev. A [07/30/2016]

DIMENSIONS

Figure 1 - Dimensions

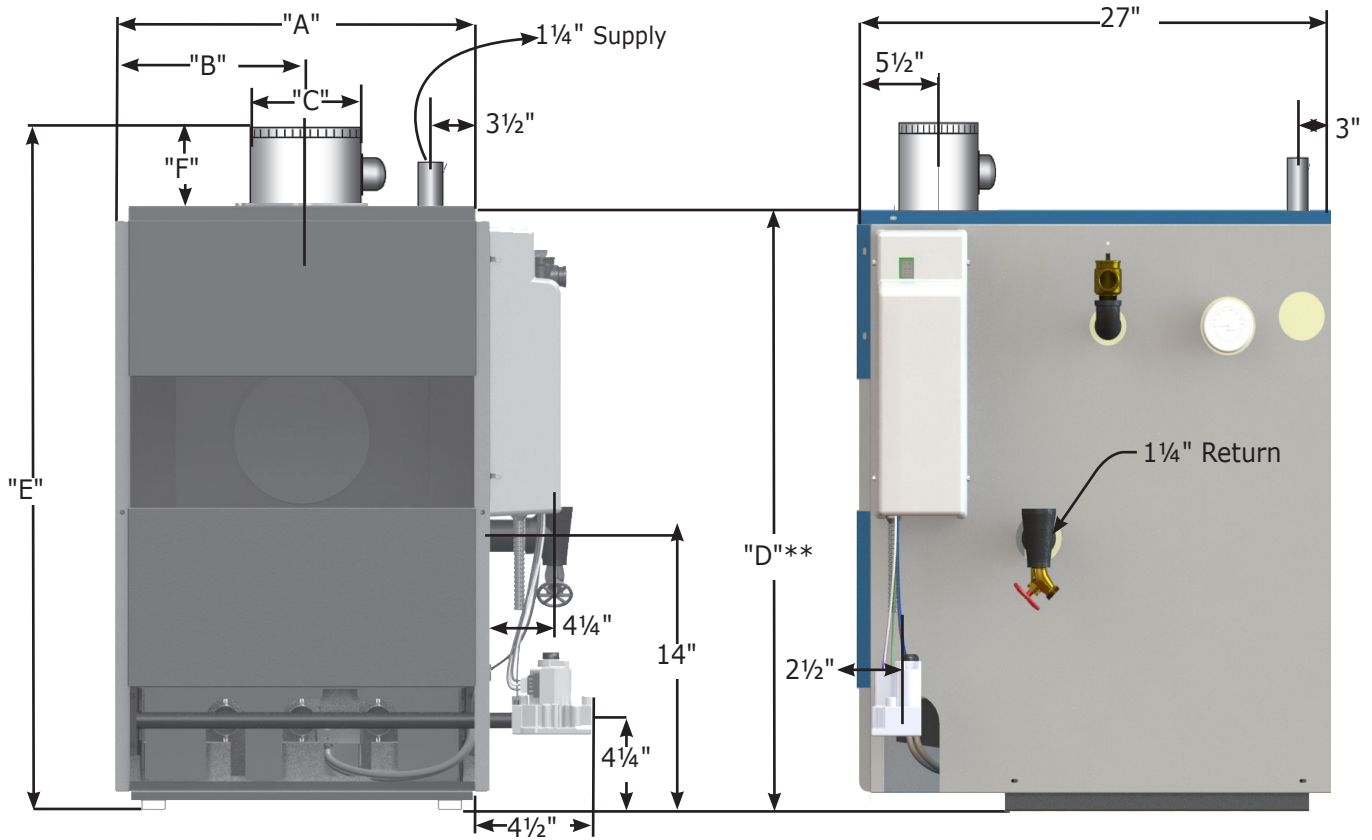

Table 1 - Dimensions

Boiler No.	Natural Gas Inlet*	Dimensions						Pump size Supply & Return Tappings
		A	B	C	D**	E	F	
50	1/2"	11 1/8"	5 1/2"	4"	30 3/4"	36 1/4"	5 3/4"	1 1/4"
75	1/2"	15"	7 1/2"	5"	30 3/4"	37 3/4"	5 3/4"	1 1/4"
100	1/2"	15"	7 1/2"	6"	30 3/4"	37 1/4"	6"	1 1/4"
125	1/2"	18 7/8"	9 1/2"	6"	30 3/4"	37 1/4"	6"	1 1/4"
150	1/2"	18 7/8"	9 1/2"	7"	30 3/4"	37 3/4"	6 3/4"	1 1/4"
170	1/2"	22 3/4"	11 1/2"	7"	30 3/4"	38 3/4"	6 3/4"	1 1/4"
200	1/2"	22 3/4"	11 1/2"	8"	30 3/4"	38 3/4"	7 3/4"	1 1/4"

* Propane gas inlet, all units, 1/2"

** D is minimum height for low water cutoff installation

SAFETY SYMBOLS AND WARNINGS

Dimensions.....	2
Safety Symbols and Warnings	3
Ratings & Data - Natural Gas & Propane Gas	4
Installation Procedure	5
Ventilation & Combustion Air	6
Connecting Supply and Return Piping	7
Connecting Supply and Return Piping	8
Vent Installation	12
Vent System Modification.....	12
Vent Damper Installation & Instructions.....	13
Connecting Gas Service	14
Electrical Section	15
Wiring Diagram	16
Lighting Instructions	18
Normal Sequence of Operation	19
General Instructions	19
Checking Gas Input Rate To Boiler	21
Appendix A - Control Module.....	22
Appendix B-1 - Vent Damper Harness	30
Appendix B-2 - Vent Damper Troubleshooting.....	31

Safety Symbols & Warnings

The following defined symbols are used throughout this manual to notify the reader of potential hazards of varying risk levels.

DANGER

Indicates a hazardous situation which, if not avoided, WILL result in death or serious injury

WARNING

Indicates a hazardous situation which, if not avoided, could result in death or serious injury.

CAUTION

Indicates a hazardous situation which, if not avoided, could result in minor or moderate injury.

NOTICE

Used to address practices not related to personal injury.

**KEEP THIS MANUAL NEAR BOILER
RETAIN FOR FUTURE REFERENCE**

**IMPORTANT: Read the following instructions
COMPLETELY before installing!!**

WARNING

Fire, explosion, asphyxiation and electrical shock hazard. Improper installation could result in death or serious injury. Read this manual and understand all requirements before beginning installation.

WARNING

Keep boiler area clear and free from combustible materials, gasoline and other flammable vapors and liquids.
DO NOT obstruct air openings to the boiler room. Modification, substitution or elimination of factory equipped, supplied or specified components may result in personal injury or loss of life.
TO THE OWNER - Installation and service of this boiler must be performed by a qualified installer.
TO THE INSTALLER - Leave all instructions with boiler for future reference.
When this product is installed in the Commonwealth of Massachusetts the installation must be performed by a Licensed Plumber or Licensed Gas Fitter.

CAUTION

Laceration, burn hazard. Metal edges and parts may have sharp edges and/or hot. Use appropriate personal protection equipment to include safety glasses and gloves when installing or servicing this boiler. Failure to follow these instructions could result in minor or moderate injury.



Table 2 - Ratings and Capacities

Boiler No.	(1) Input Mbh	(1) Heating Capacity Mbh	(2) Net AHRI Rating Water Mbh	AFUE	No. of Burners	(3) Recommended Air Cushion Tank	Water Content (Gals.)	(1) High Altitude Input Mbh
50J	50	42	37	83.5	1	15	2.4	45
75J	75	63	55	83.1	2	15	4.0	67.5
100J	100	83	72	83.0	2	30	4.0	90
125J	125	104	90	82.0	3	30	5.6	112.5
150J	150	124	108	83.0	3	30	5.6	135
170J	170	139	121	82.0	4	30	7.2	153
200J	200	165	143	82.0	4	30	7.2	180

EXPLANATORY NOTES

- All boilers are design certified for installation on noncombustible floor.
- For installation on combustible floors use combustible floor kit.
- Recommended chimney height 20 feet. In special cases where conditions permit, chimney height may be reduced to 10 feet. Refer to the latest revision of NFGC part 11.
- Electric service to be 120 Volts, 15 Amps, 60 Hz.
- The MEA number for the this boiler is 19-79-E.

(1) Input rating for sea level to 2,000 ft. (610m) above sea level.

United States, over 2000 ft (610m) above sea level. Reduce input rate 4% for every 1000 ft (304m) above sea level.

Canada, 2000 ft (610m) to 4500 (1350m) above sea level reduce input per table. Over 4500 ft (1350m) above sea level. Contact Provincial authority having jurisdiction.

(2) Net AHRI Water Ratings shown based on piping and pickup allowance of 1.15. Consult manufacturer before selecting boiler for installations having unusual piping and pickup requirements, such as intermittent system operation, extensive piping systems, etc.

For forced hot water systems where boiler and all piping within area to be heated, boiler may be selected on basis of its heating capacity.

(3) Tank sized for non-ferrous baseboard or radiant panel systems. Increase size for cast iron baseboard and radiation.

STANDARD EQUIPMENT: Boiler Jacket, Cast Iron Boiler Battery, High Limit Control, Intermittent Electric Ignition Pilot System, Vent Damper Relay, Theraltimeter Gauge, Circulator With Return Piping To Boiler, Main Gas Burners, Gas Control (Includes Automatic Gas Valve, Gas Pressure Regulator, Intermittent Pilot, Safety Shutoff, Pilot Flow Adjustment, Pilot Filter), A.S.M.E. Relief Valve, Drain Valve, Spill Switch, Rollout Switch, Combination Gas Control, Automatic Vent Damper. Not Shown Are: Wiring Harness, Thermocouple, Non-linting Safety Pilot.

INSTALLATION PROCEDURE

⚠ WARNING

Improper installation, adjustment, alteration, service or maintenance could result in death or serious injury.

1. Installation must conform to the requirements of the authority having jurisdiction or, in the absence of such requirements, to the National Fuel Gas Code, ANSI Z223.1/NFPA 54, and/or Natural Gas and Propane Installation Code, CAN/CSA B149.1.
2. Where required by the authority having jurisdiction, the installation must conform to the Standard for Controls and Safety Devices for Automatically fired Boilers, ANSI/ASME CSD-1.
3. Boiler series is classified as a Category I. Vent installation shall be in accordance with "Venting of Equipment," of the National Fuel Gas Code, ANSI Z223.1/NFPA 54, or "Venting Systems and Air Supply for Appliances," of the Natural Gas and Propane Installation Code, CAN/CSA B149.1, or applicable provisions of the local building codes.
4. Boiler has met safe lighting and other performance criteria with the gas manifold and control assembly on the boiler per the latest revision of ANSI Z21.13/CGA 4.9.
5. Install boiler such that gas ignition system components are protected from water (dripping, spraying, rain, etc.) during appliance operation and service, (circulator replacement, condensate trap, control replacement, etc.).
6. Locate boiler on level, solid base as near chimney as possible and centrally located with respect to heat distribution system as practical.
7. Allow 24 inches (610mm) at front and right side for servicing and cleaning.
8. When installed in utility room, door should be wide enough to allow largest boiler part to enter, or to permit replacement of another appliance such as water heater.

⚠ WARNING

Fire hazard. Do not install boiler on combustible flooring or carpeting. Failure to follow these instructions could result in death or serious injury.

9. FOR INSTALLATION ON NON-COMBUSTIBLE FLOORS ONLY - For installation on combustible flooring special base must be used. (See Repair Parts, Optional Kits Manual). Do not install boiler on carpeting. Minimum clearances to combustible construction are:

TOP	18 IN. (457mm)
FRONT	ALCOVE *
FLUE CONNECTOR	6 IN. (152mm)
REAR	4 IN. (102mm)
CONTROL SIDE	9 IN. (229mm)
OTHER SIDE	3 IN. (76mm)
HOT WATER PIPING	Per Local Code

NOTE: Greater clearances for access should supersede fire protection clearances.

* Definition of Alcove is three sided space with no wall in front of boiler. ANSI standard for alcove is 18 inches from front of appliance to leading edge of side walls as shown below.

Minimum Clearances to Combustible Construction *(as seen from above)*

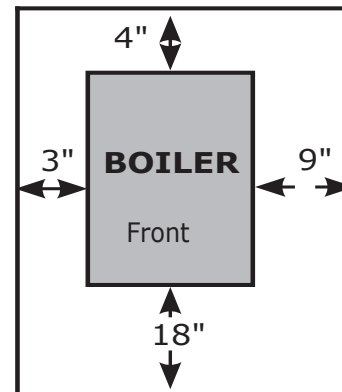

VENTILATION & COMBUSTION AIR

Provide combustion air and ventilation air in accordance with the section "Air for Combustion and Ventilation," of the National Fuel Gas Code, ANSI Z223.1/NFPA 54, or Sections 8.2, 8.3 or 8.4 of Natural Gas and Propane Installation Code, CAN/CSA B149.1, or applicable provisions of local building codes.

Provide make-up air where exhaust fans, clothes dryers, and kitchen ventilation equipment interfere with proper operation.

National Fuel Gas Code recognizes several methods of obtaining adequate ventilation and combustion air. Requirements of the authority having jurisdiction may override these methods.

- » Engineered Installations. Must be approved by authority having jurisdictions.
- » Mechanical Air Supply. Provide minimum of 0.35 cfm per Mbh for all appliances located within space. Additional requirements where exhaust fans installed. Interlock each appliance to mechanical air supply system to prevent main burner operation when mechanical air supply system not operating.
- » All Indoor Air. Calculate minimum volume for all appliances in space. Use a different method if minimum volume not available.
 - o Standard Method. Cannot be used if known air infiltration rate is less than 0.40 air changes per hour. See Table 3 for space with boiler only. Use equation for multiple appliances.

$$\text{Volume} \geq 50 \text{ ft}^3 \times \text{Total Input [Mbh]}$$
 - o Known Air Infiltration Rate. See Table 3 for space with boiler only. Use equation for multiple appliances. Do not use an air infiltration rate (ACH) greater than 0.60.

$$\text{Volume} \geq 21 \text{ ft}^3/\text{ACH} \times \text{Total Input [Mbh]}$$
 - o Refer to National Fuel Gas Code for opening requirements between connection indoor spaces.

- » All Outdoor Air. Provide permanent opening(s) communicating directly or by ducts with outdoors.
 - o Two Permanent Opening Method. Provide opening commencing within 12 inches of top and second opening commencing within 12 inches of bottom enclosure.
 - Direct communication with outdoors or communicating through vertical ducts. Provide minimum free area of 1 in² per 4 Mbh of total input rating of all appliances in enclosure.
 - Communicating through horizontal ducts. Provide minimum free area of 1 in² per 2 Mbh of total input rating of all appliances in enclosure.
 - o One Permanent Opening Method. Provide opening commencing within 12 inches of top of enclosure. Provide minimum clearance of 1 inch on sides and back and 6 inches on front of boiler (does not supersede clearance to combustible materials).
- » Refer to National Fuel Gas Code for additional requirements for louvers, grilles, screens and air ducts.
- » Combination Indoor and Outdoor Air. Refer to National Fuel Gas Code for application information.

National Gas and Propane Installation Code Requires providing air supply in accordance with:

- » Section 8.2 and 8.3 when combination of appliances has a total input of up to and including 400 Mbh (120 kW).
 - o Does not have draft control device.
- » Section 8.4 when combination of appliances has total input exceeding 400 Mbh (120 kW).
- » Refer to Natural Gas and Propane Installation Code for specific air supply requirements for enclosure or structure where boiler is installed, including air supply openings and ducts.

Table 3 - Space With Boiler Only

Input Mbh	Room Cubic Feet Volume						
	Standard Method	Known Air Infiltration Rate Method (ACH - Air Changes Per Hour)					
		0.1	0.2	0.3	0.4	0.5	0.6
50	2500	10500	5250	3500	2625	2100	1750
75	3750	15750	7875	5250	3938	3150	2625
100	5000	21000	10500	7000	5250	4200	3500
125	6250	26250	13125	8750	6563	5250	4375
150	7500	31500	15750	10500	7875	6300	5250
170	8500	35700	17850	11900	8925	7140	5950
200	10000	42000	21000	14000	10500	8400	7000

CONNECTING SUPPLY AND RETURN PIPING

⚠ WARNING

Burn or Scald Hazard. Discharge line shall be installed to relief valve outlet connection to avoid burns, scalding, or water damage due to discharge of steam and/or hot water during operation.

Discharge line shall:

- » connect to relief valve outlet and piped down to safe point of disposal. Check local codes for maximum distance from floor or allowable safe point of discharge.
- » be of pipe size equal to or greater than that of the relief valve outlet over the entire length of discharge line;
- » have no intervening shutoff valve between safety relief valve and discharge to atmosphere (do not plug or place any obstruction in discharge line.
- » terminate freely to atmosphere where any discharge will be clearly visible and at no risk of freezing;
- » allow complete drainage of the valve and the discharge line;
- » be independently supported and securely anchored to avoid applied stress on the relief valve;
- » be as short and straight as possible;
- » terminate with plain end (not threaded);
- » be constructed of material suitable for exposure to temperatures of 375° F (191°C); or greater.

Refer to local codes and appropriate ASME Boiler and Pressure Vessel Code for additional installation requirements.

Figure 2 - Safety Relief Valve

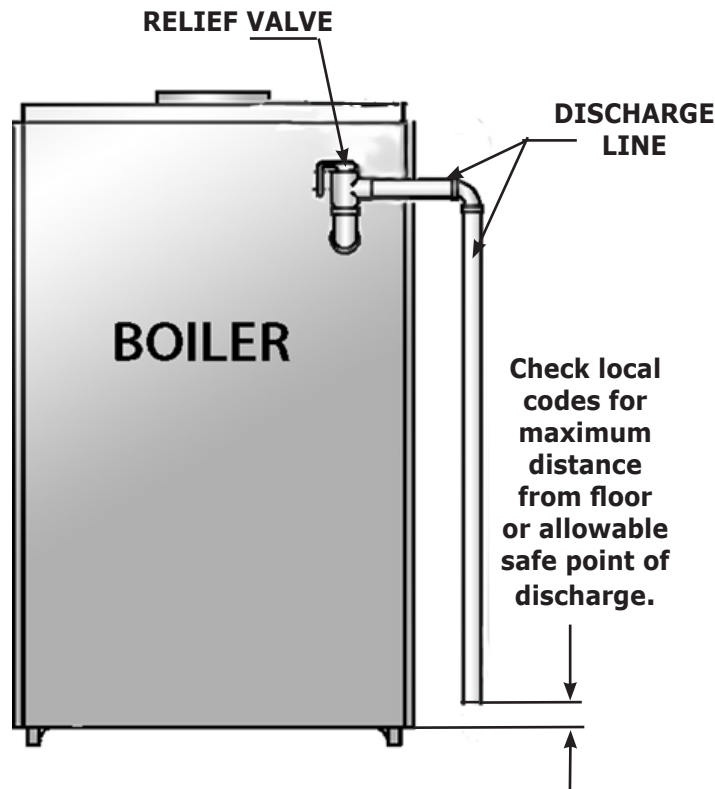

CONNECTING SUPPLY AND RETURN PIPING

Circulators in following illustrations are mounted on system supply side, mounting on system return side is also acceptable practice.

Figure 3 - Circulators Mounted on Supply System, Boiler Used In Configuration with Chiller System. See Special Conditions, Page 9

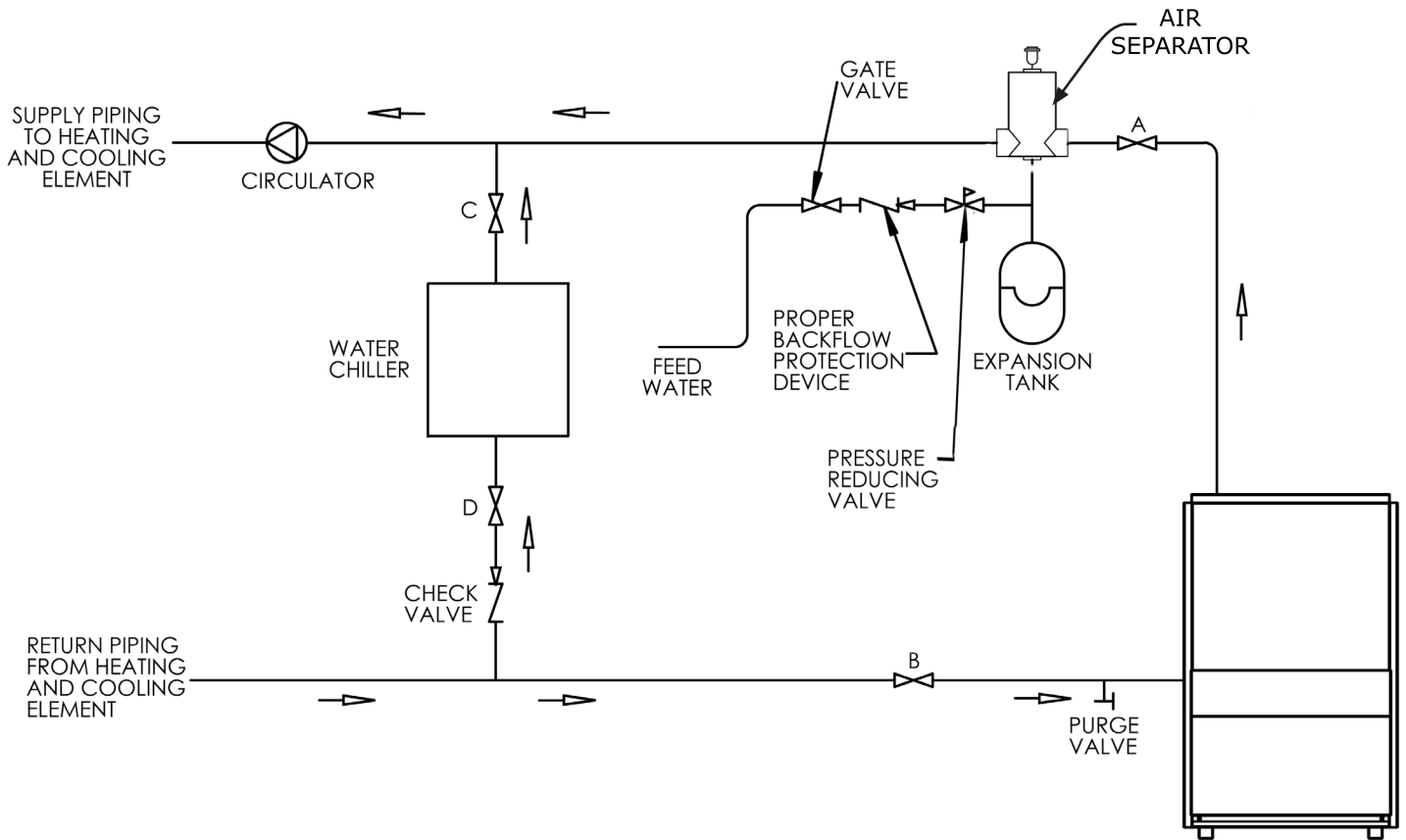

1. Boiler used in connection with refrigeration system, install so chilled medium is piped in parallel with boiler with appropriate valves to prevent chilled medium from entering boiler. See Figure 3.
 2. Boiler piping system of hot water boiler connected to heating coils located in air handling units where they may be exposed to refrigerated air circulation must be equipped with flow control valves or other automatic means to prevent gravity circulation of boiler water during cooling cycle.
 3. Hot water boilers installed above radiation level or as required by authority having jurisdiction must be provided with low water cut-off device.
 4. Boiler connected to heating system utilizing multiple zoned circulators, each circulator must be supplied with flow control valve to prevent gravity circulation.
 5. Hot water boilers and system must be filled with water and maintained to minimum pressure of 12 psi.
 6. For Low Water Cutoff, see Figure 1 for minimum height. Use Kit #550002998 and follow instructions enclosed with kit. For other LWCO's follow their manufacture specific instructions.
 7. Bypass piping is optional which gives ability to adjust supply boiler water temperature to fit system or condition of installation. This method of piping, however, is not typically required for baseboard heating systems. Typical installations where bypass piping is used are as follows:
 - A. This method is used to protect boilers from condensation forming due to low temperature return water. Generally noticed in large converted gravity systems or other large water volume systems. Figures 4 and 5.
 - B. These methods are used to protect systems using radiant panels and material they are encased in from high temperature supply water from boiler and protect boiler from condensation.
- NOTE#1:** When using bypass piping, adjust valves V1 & V2 until desired system temperature is obtained. See Figure 5, page 9.
- NOTE#2:** Bypass loop must be same size piping as supply and return piping.

CONNECTING SUPPLY AND RETURN PIPING

Figure 4 - Bypass Piping With Mixing Valve

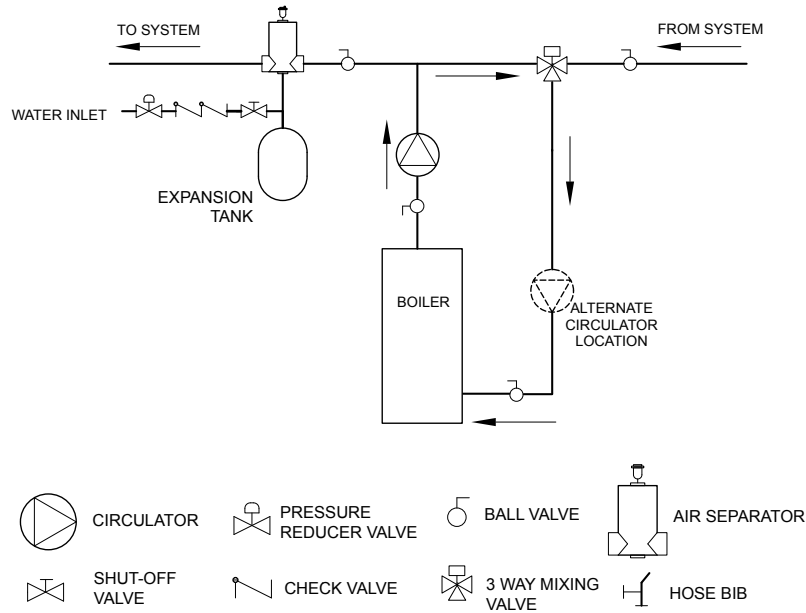
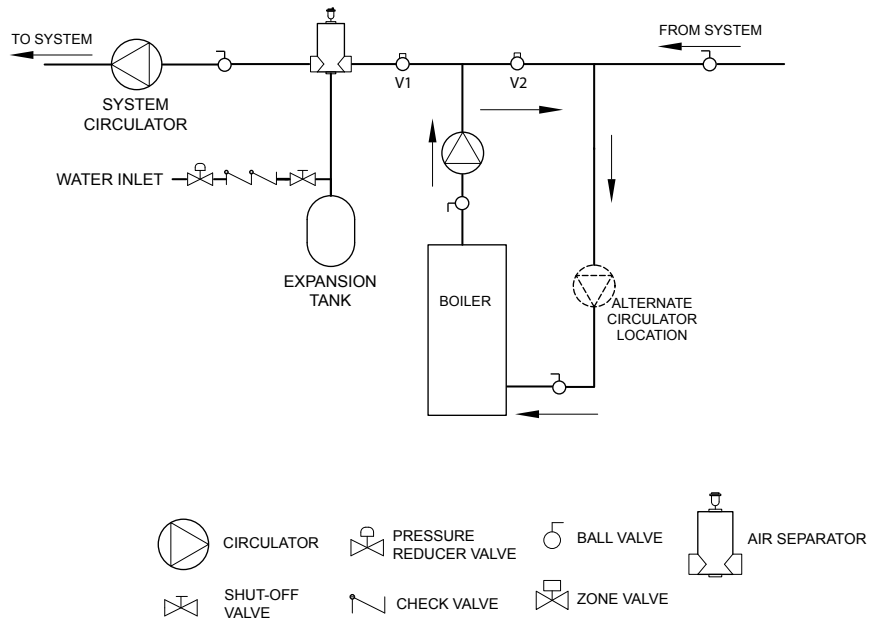

Figure 5 - Bypass Piping - Fixed Low Temp Only With Zone Valve



8. Installation using circulators and zone valves are shown in Figures 6 through 9. For further piping information refer to AHRI Installation and Piping Guide.

⚠ WARNING

Burn and scald hazard. Safety relief valve could discharge steam or hot water during operation. Install discharge piping per these instructions.

9. Install discharge piping from safety relief valve. See Warning, Page 7 and Figure 2.

CONNECTING SUPPLY AND RETURN PIPING

Figure 6 - Single Zone System With DHW

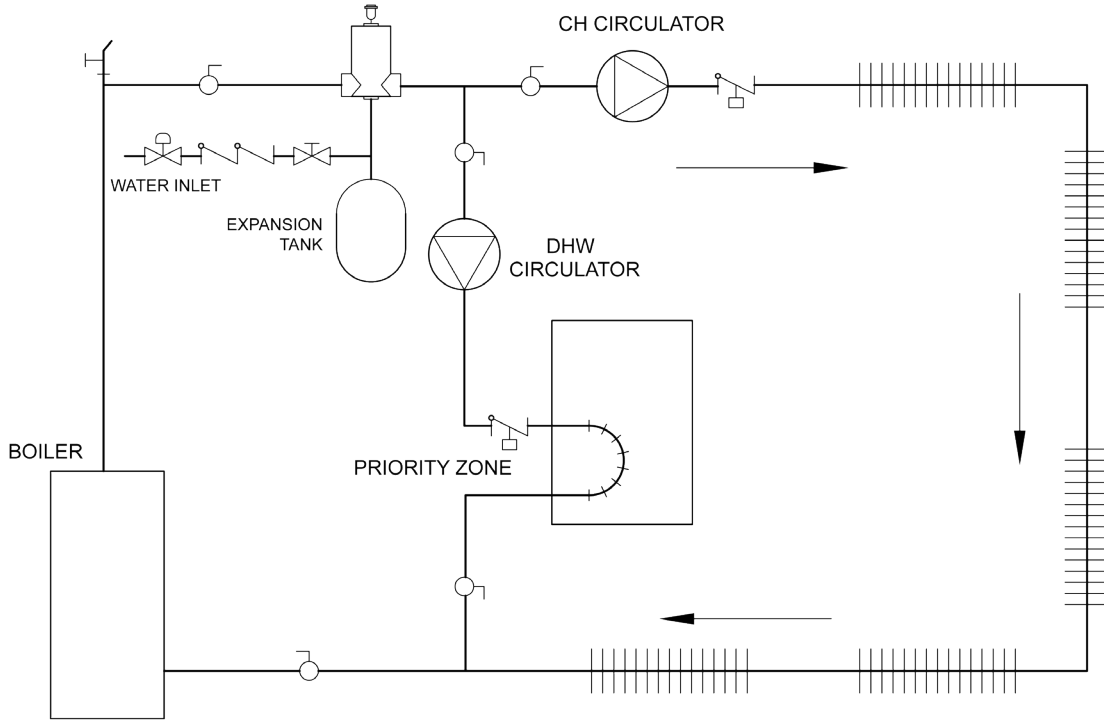
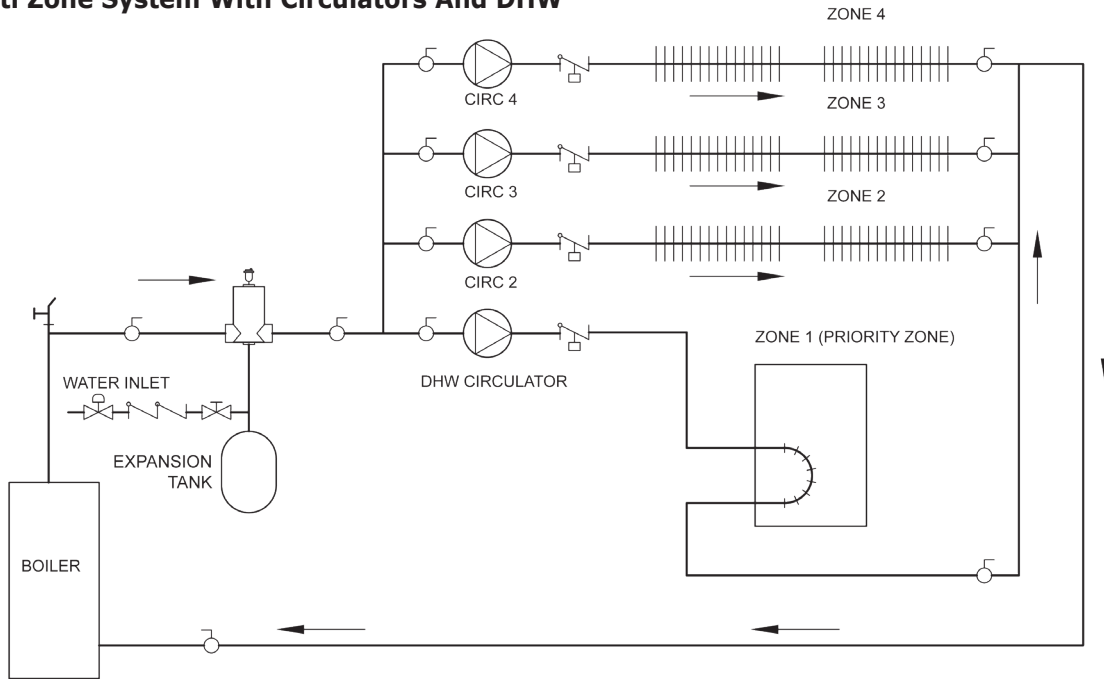

Figure 7 - Multi Zone System With Circulators And DHW



CONNECTING SUPPLY AND RETURN PIPING

Figure 8 - Multi Zone System With Zone Valves And DHW (With Circulator)

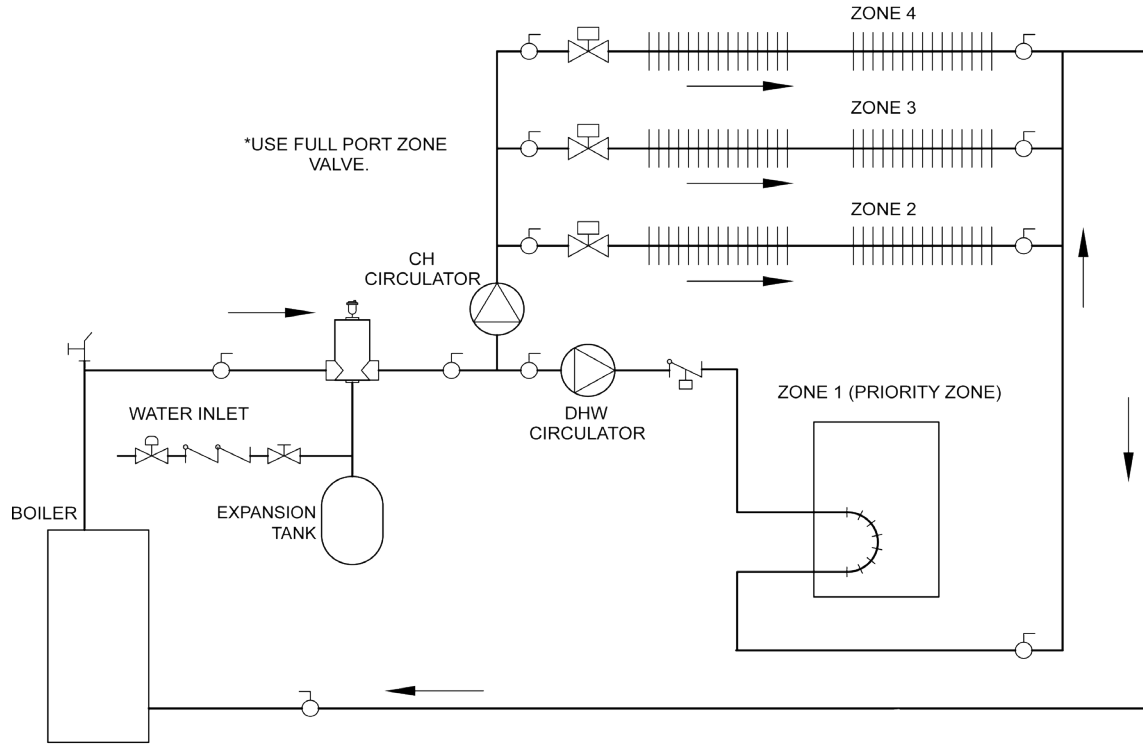
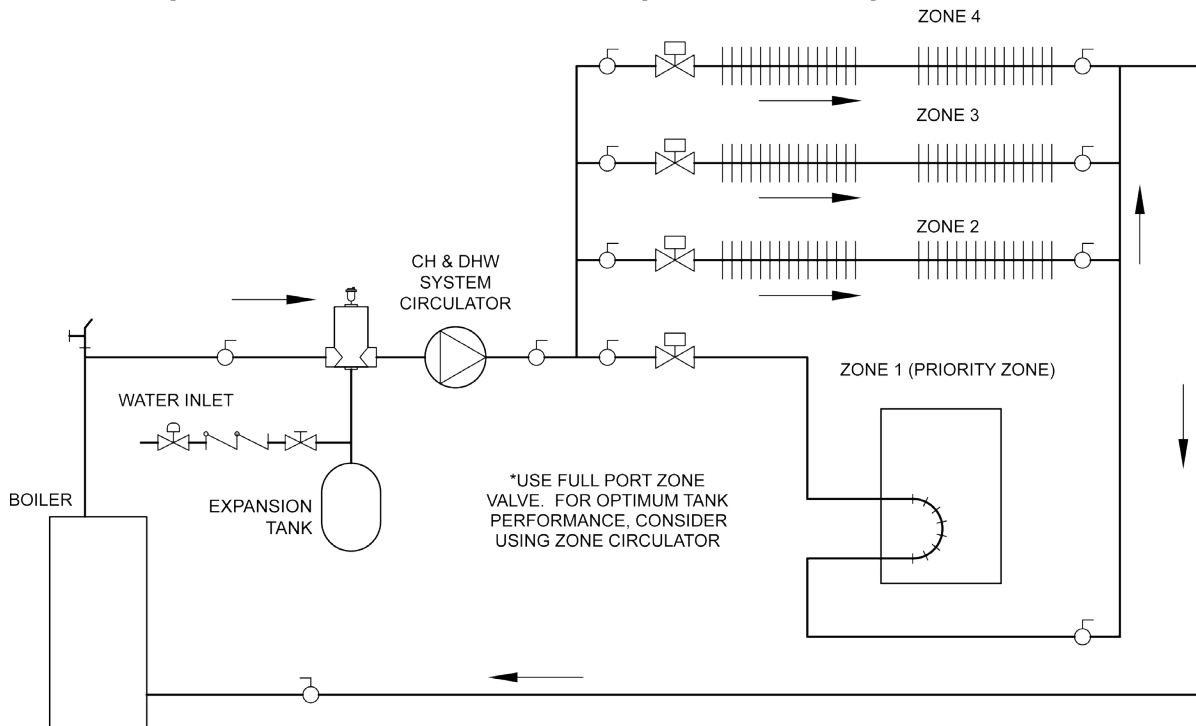

Figure 9 - Multi Zone System With Zone Valves And DHW (With Zone Valve)



VENT INSTALLATION

WARNING

Boiler and venting installations shall be performed by a qualified expert and in accordance with the appropriate manual. Installing or venting boiler or other gas appliance with improper methods or materials may result in serious injury or death due to fire or to asphyxiation from poisonous gases such as carbon monoxide which is odorless and invisible.

WARNING

Do not connect boiler to any portion of mechanical draft system operating under positive pressure.

1. Vent pipe must slope upward from the boiler not less than $\frac{1}{4}$ inch for every 1 foot (21mm/m) to vent terminal.
2. Horizontal portions of venting system shall be supported rigidly every 5 feet and at the elbows. No portion of vent pipe should have any dips or sags.
3. Boiler series is classified as a Category I. Vent installation shall be in accordance with "Venting of Equipment," of the National Fuel Gas Code, ANSI Z223.1/NFPA 54, or "Venting Systems and Air Supply for Appliances," of the Natural Gas and Propane Installation Code, CAN/CSA B149.1, or applicable provisions of the local building codes.
4. Inspect chimney. Verify chimney is constructed according to NFPA 211. Vent or vent connector shall be Type B or metal pipe having resistance to heat and corrosion not less than that of galvanized sheet steel or aluminum not less than 0.016 inch thick (No. 28 Ga).
5. Connect flue pipe from draft hood to chimney. Bolt or screw joints together to avoid sags. Flue pipe should not extend beyond inside wall of chimney. Do not install manual damper in flue pipe or reduce size of flue outlet except as provided by the latest revision of ANSI Z223.13 or CAN/CSA B149.1. Protect combustible ceiling and walls near flue pipe with fireproof insulation. Where two or more appliances vent into a common flue, the area of the common flue must be at least equal to the area of the largest flue plus 50 percent of the area of each additional flue.

VENT SYSTEM MODIFICATION

When an existing boiler is removed from a common venting system, the system is likely to be too large for the proper venting of the appliances still connected to it. If this situation occurs, the following test procedure must be followed:

REMOVAL OF BOILER FROM VENTING SYSTEM

At the time of removal of an existing boiler, the following steps shall be followed with each appliance remaining connected to the common venting system placed in operation, while the other appliances remaining connected to the common venting system are not in operation.

1. Seal an unused opening in the common venting system.
2. Visually inspect the venting system for proper size and horizontal pitch and determine there is no blockage or restriction, leakage, corrosion and other deficiencies which could cause an unsafe condition.
3. Insofar as is practical, close all building doors and windows and all doors between the space in which the appliances remaining connected to the common venting system are located and other spaces of the building. Turn on clothes dryers and any other appliance not connected to the common venting system. Turn on any exhaust fans, such as range hoods and bathroom exhausts, so they operate at maximum speed. Do not operate a summer exhaust fan. Close fireplace dampers.
4. Place in operation the appliance being inspected. Follow the lighting instructions. Adjust thermostat so appliance will operate continuously.
5. Test for spillage at the draft hood relief opening after 5 minutes of main burner operation. Use the flame of a match or candle, or smoke from a cigarette, cigar or pipe.
6. After it has been determined that each appliance remaining connected to a common venting system properly vents when tested as outlined above, return doors, windows, exhaust fans, fireplace dampers and any other gas burning appliances to their previous condition of use.
7. Any improper operation of the common venting system should be corrected so the installation conforms with the National Fuel Gas Code, ANSI Z223.1/NFPA 54, and/or the Natural Gas and Propane Installation Code, CAN/CSA B149.1. When re-sizing any portion of the common venting system, the common venting system should be re-sized to approach the minimum size determined using the appropriate tables in Chapter 13 of the National Fuel Gas Code, ANSI Z223.1/NFPA 54, and/or the Natural Gas and Propane Installation Code, CAN/CSA B149.1.

VENT DAMPER INSTALLATION & INSTRUCTIONS

DAMPER INSTALLATION

Follow Damper installation instructions provided with damper. See **Figure 10**.

Figure 10 - Damper Motor Wiring

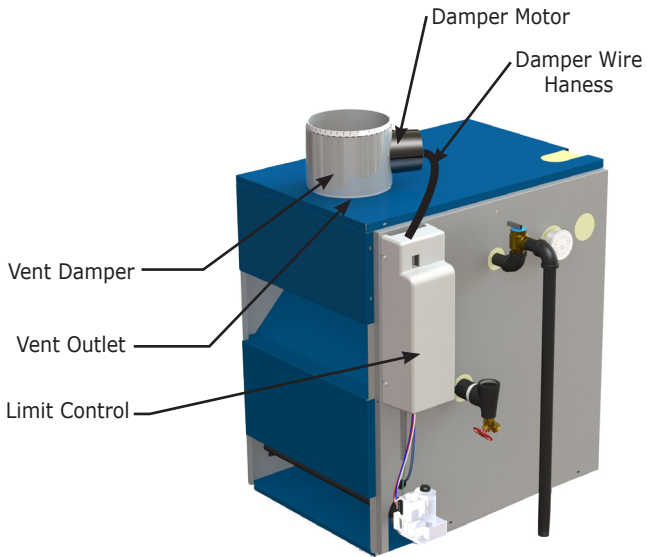

DAMPER INSTRUCTIONS

Figure 11 - Vent Damper Placement

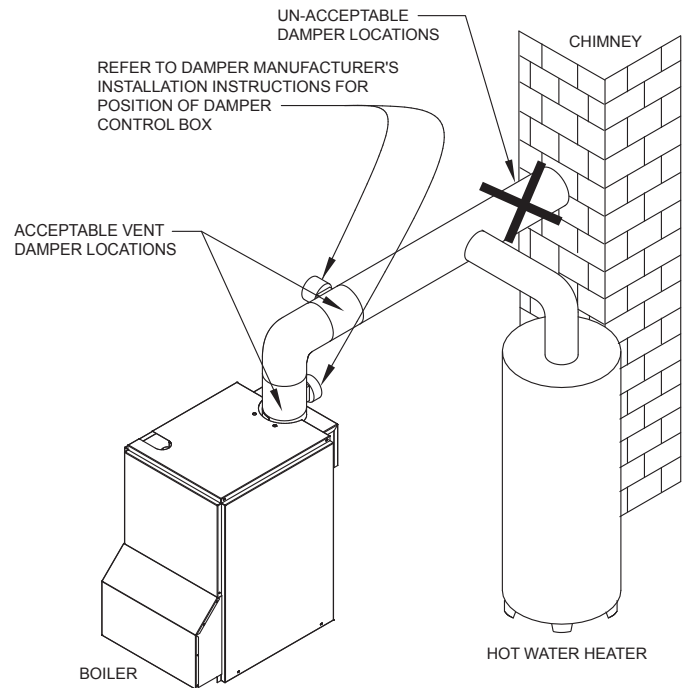

1. Verify only boiler is serviced by Vent Damper. Figure 11.
2. Clearance of not less than 6 inches (152mm) between Vent Damper and combustible material must be maintained. Additional clearance should be allowed for service of Vent Damper.
3. Vent Damper must be in the open position when appliance main burners are operating.
4. Vent Damper position indicator must be in visible location following installation.
5. Thermostat's heat anticipator must be adjusted to match total current draw of all controls associated with boiler during heating cycle.

CAUTION

WHAT TO DO IF YOU SMELL GAS

- » Do not try to light any appliance.
- » Do not touch any electrical switch; do not use any phone in your building.
- » Immediately call your gas supplier from a neighbor's phone. Follow gas supplier's instructions.
- » If you cannot reach your gas supplier, call the fire department.

Figure 12 - Gas Piping

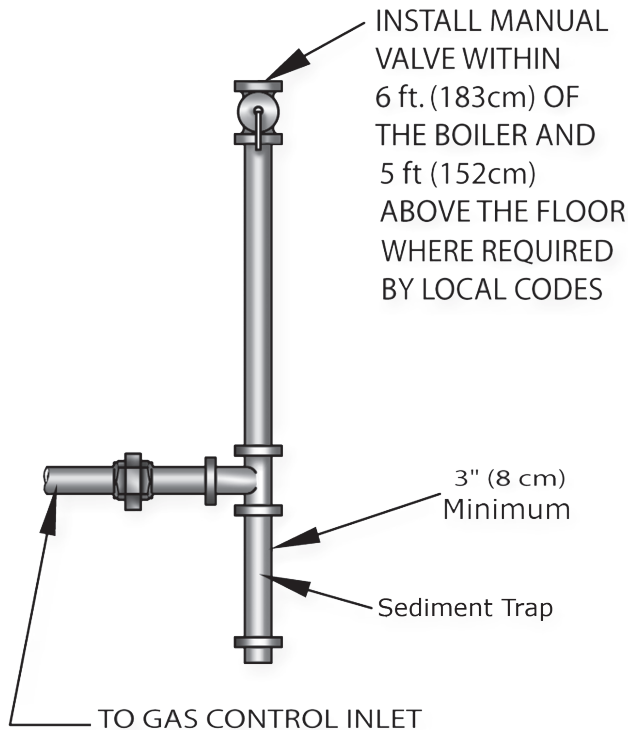

MAXIMUM CAPACITY OF PIPE IN CUBIC FEET OF GAS/HOUR

(Gas Pressure = 0.5 psig or less, Pressure Drop = 5 in. w/c)

Table 4				
Length of Pipe (Feet)	Nominal Iron Pipe Size			
	1/2"	3/4"	1"	1 1/4"
10	175	360	680	1400
20	120	250	465	950
30	97	200	375	770
40	82	170	320	660
60	66	138	260	530
80	57	118	220	460
100	50	103	195	400

For additional information refer to the National Fuel Gas Code Handbook.

General

- » Use piping materials and joining methods acceptable to authority having jurisdiction. In absence of such requirements:
 - » USA - National Fuel gas Code, ANSI Z223.1/NFPA 54
 - » Canada - Natural Gas and Propane Installation Code, CAN/CSA B149.1
- » Size and install gas piping system to provide sufficient gas supply to meet maximum input at not less than minimum supply pressure. See Table 4.
- » Support piping with hooks straps, bands, brackets, hangers, or building structure components to prevent or dampen excessive vibrations and prevent strain on gas connection. Boiler will not support piping weight.
- » Use thread (joint) compound (pipe dope) suitable for liquefied petroleum gas.
- » Install field sourced manual main shutoff valve, ground joint union, and sediment trap upstream of gas valve. See Figure 12.

Table 5	Natural Gas	Propane
Min. Supply Pressure	5" w.c.	11" w.c.
Max. Supply Pressure	13.5" w.c.	13.5" w.c.
Manifold Pressure	3.5" w.c.	10.5" w.c.

DANGER

Fire Hazard. Do not use matches, candles, open flames, or other methods providing ignition source. Failure to comply will result in death or serious injury.

Leak Check Gas Piping

Pressure test boiler and gas connection before placing boiler in operation.

- » Pressure test over 1/2 psig (3.5 kPa). Disconnect boiler and its individual gas shutoff valve from gas supply system.
- » Pressure test at 1/2 psig (3.5 kPa) or less. Isolate boiler from gas supply system by closing manual gas shutoff valve.
- » Locate leakage using gas detector, non-corrosive detection fluid, or other leak detection method acceptable to authority having jurisdiction. Do not use matches, candles, open flames, or other methods providing ignition source.
- » Correct leaks immediately and retest.

WARNING

Electrical shock hazard. Turn OFF electrical power supply at service panel before making electrical connections. Failure to do so could result in death or serious injury.

ELECTRICAL WIRING

See wiring diagrams on the following two pages for details.

Electrically bond boiler to ground in accordance with requirements of authority having jurisdiction. Refer to:

- » USA- National Electrical Code, ANSI/NFPA 70.
- » Canada - Canadian Electrical Code, Part I, CSA C22.1: Safety Standard for Electrical Installations.

If using LWCO kit 550002998 wiring instructions and wiring diagram are included with the kit.

THERMOSTAT INSTALLATION

1. Thermostat should be installed on inside wall about four feet above floor.
2. NEVER install thermostat on outside wall.
3. Do not install thermostat where it will be affected by drafts, hot or cold pipes, sunlight, lighting fixtures, televisions, fireplace, or chimney.
4. Check thermostat operation by raising and lowering thermostat setting as required to start and stop burners.
5. Instructions for final adjustment of thermostat are packaged with thermostat (adjusting heating anticipator, calibration, etc.)

WIRING DIAGRAM

Figure 14 - Integrated High Limit Electronic Ignition Control

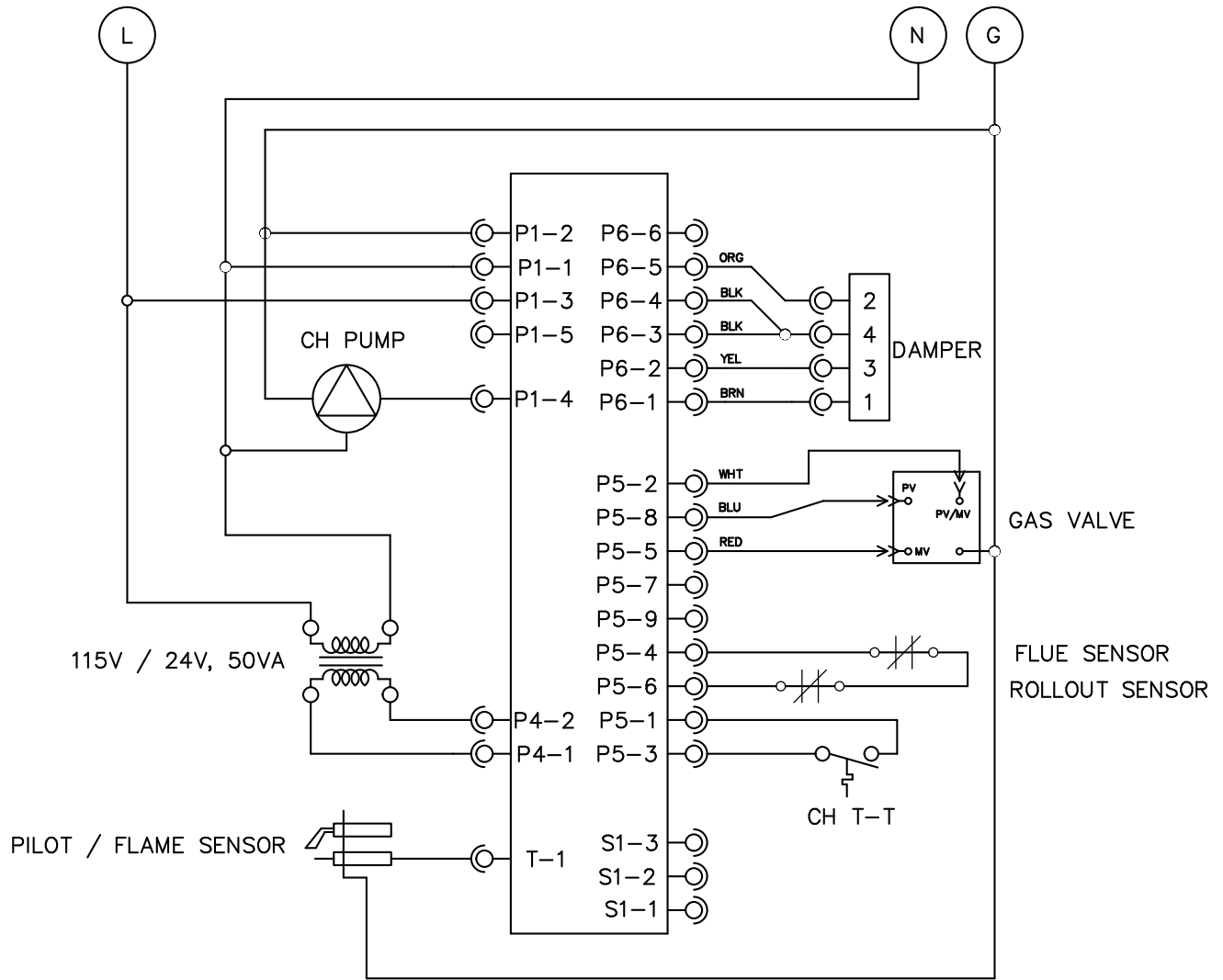

LADDER DIAGRAM: HOT WATER - ATMOSPHERIC DRAFT BOILER

LIGHTING INSTRUCTIONS

⚠ WARNING

If you do not follow these instructions exactly, a fire or explosion may result causing property damage, personal injury or loss of life.

- » This appliance is equipped with an ignition device which automatically lights burner. **Do NOT try to light this burner by hand.**
- » Before operating smell all around appliance area for gas. Be sure to smell next to floor because some gas is heavier than air and will settle to the floor.
- » **Use only your hand to turn the gas shutoff valve.** Never use tools. If valve will not turn by hand, do not try to repair it, call a qualified service technician. Force or attempted repair may result in fire or explosion.
- » **Do not use this appliance if any part has been under water.** Immediately call a qualified service technician to inspect appliance and to replace any part of control system and any gas control which has been under water.

NOTICE

Before lighting any type of pilot burner (standing or intermittent), verify the hot water boiler and system are full of water to minimum pressure of 12 psi in the system, also verify system is vented of air. Set operating control of thermostat to "below" normal setting. Refer to following appropriate lighting instruction.

LIGHTING PROCEDURE FOR BOILER WITH INTERMITTENT PILOT SYSTEM

- A. This appliance is equipped with an ignition device which automatically lights the pilot. Do not try to light the appliance by hand.

⚠ CAUTION

WHAT TO DO IF YOU SMELL GAS



- » Do not try to light any appliance.
- » Do not touch any electrical switches; do not use any phone in your building.
- » Immediately call your gas supplier from a neighbor's phone. Follow the gas supplier's instructions.
- » If you cannot reach your gas supplier, call the fire department.

OPERATING INSTRUCTIONS FOR INTERMITTENT PILOT SYSTEM

1. STOP! Read the safety information to the left.
2. Set the thermostat to lowest setting.
3. Turn off all electric power to the appliance.
4. This appliance is equipped with an ignition device which automatically lights the pilot. Do not try to light the pilot by hand.

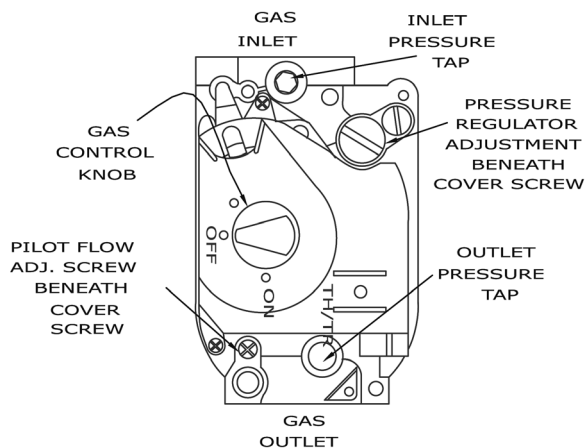
Figure 15 - Intermittent Pilot



5. Turn gas control knob clockwise  to "OFF."
6. Wait (5) minutes to clear out any gas. If you then smell gas, STOP! Follow "What To Do If You Smell Gas" in the safety information to the left. If you don't smell gas, go on to the next step.
7. Turn gas control knob counterclockwise  to "ON."
8. Turn on all electric power to the appliance.
9. Set thermostat to desired setting.
10. If the appliance will not operate, follow the instructions "**To Turn Off Gas To Appliance**", and call qualified service technician or your gas supplier.

TO TURN OFF GAS TO THE APPLIANCE

1. Set the thermostat to lowest setting.
2. Turn off all electric power to the appliance if service is to be performed.
3. Push in gas control knob slightly and turn clockwise  to "OFF." DO NOT FORCE.
4. Call qualified service technician.

NORMAL SEQUENCE OF OPERATION

Thermostat actuates on call for heat, completing circuit to control. Completed circuit to control will first activate circulator and damper which will close end switch inside damper. Completes circuit to ignition system, ignition takes place.

In event boiler water temperature exceeds high limit setting on boiler mounted high limit control, power is interrupted between control system and ignition system. Power remains off until boiler water temperature drops below high limit setting. Circulator continues to operate under this condition until thermostat is satisfied.

In event flow of combustion products through boiler venting system becomes blocked, blocked vent safety switch shuts main burner gas off. Similarly, if boiler flue-way becomes blocked, flame rollout safety switch shuts main burner gas off. Figure 16. If either of these conditions occur, **DO NOT ATTEMPT TO PLACE BOILER BACK INTO OPERATION. CONTACT CERTIFIED SERVICE AGENCY.**

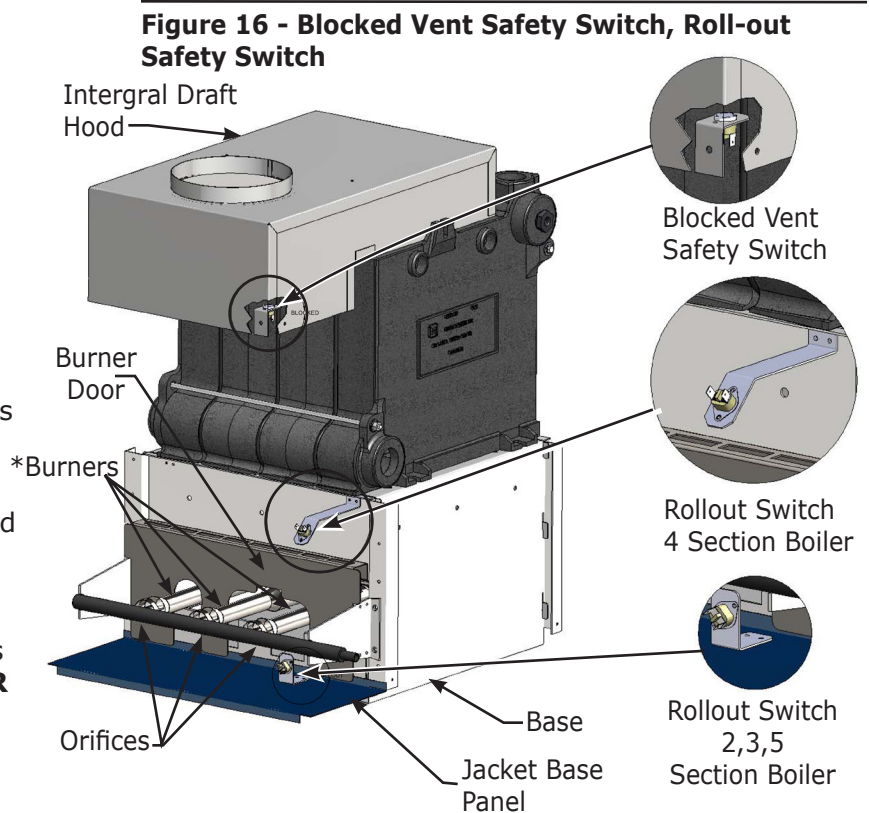

* Burner shipping retention clips (not shown) may be removed if desired.

GENERAL INSTRUCTIONS

Before seasonal start-up, have a certified service agency check boiler for soot and scale in flues, clean burners and check gas input rate to maintain high operating efficiency.

WARNING

Label all wires prior to disconnection when servicing controls. Wiring errors could cause improper and dangerous operation.

Verify proper operation after servicing

Service agency will verify system is filled with water to minimum pressure and open air vents, if used, to expel any air accumulated in the system. Check entire piping system and, if any leaks appear, have them repaired.

Circulators need to be checked and maintained. Refer to circulator manufacturer's instructions.

Inspect venting system at the start of each heating season. Check vent pipe from boiler to chimney for signs of deterioration by rust or sagging joints. Repair if necessary. Remove vent pipe at base of chimney or flue and using a mirror, check vent for obstruction and verify vent is in good working order.

Boiler flue gas passageways may be inspected by a light and mirror. Remove burner door. Figure 16. Place trouble lamp in flue collector through draft relief opening. With mirror positioned above burners, flue gas passageways can be checked for soot or scale.

This procedure should be followed to clean flue gas passageways:

1. Remove burners from combustion chamber by raising burners up from manifold orifices and pulling toward front of boiler. Figure 16.
2. Disconnect vent pipe from draft hood.
3. Remove top jacket panel.
4. Remove combination flue collector and draft hood from boiler castings by loosening nuts on hold down bolts located on each side of collector. Figure 16.
5. Place sheet of heavy paper or similar material over bottom of base and brush down flue passageways. Soot and scale will collect on paper and is easily removed with the paper.
6. With paper still in place in base, clean top of boiler castings of boiler putty or silicone used to seal between castings and flue collector. Verify chips are not lodged in flue passageways.

When cleaning process is complete, restore boiler components to their original position. Use IS-808 GE silicone (available from distributor) to seal around flue collector and boiler castings.

GENERAL INSTRUCTIONS

Figure 17 - Gas Burner Flame

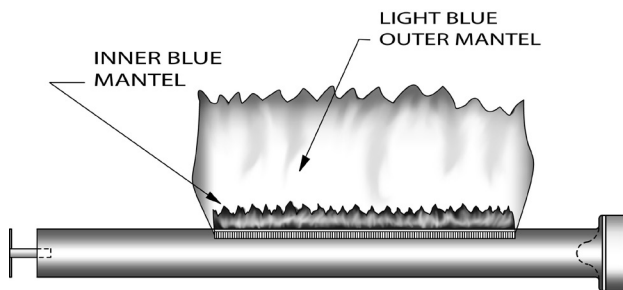

Figure 18 - Combustion Chamber

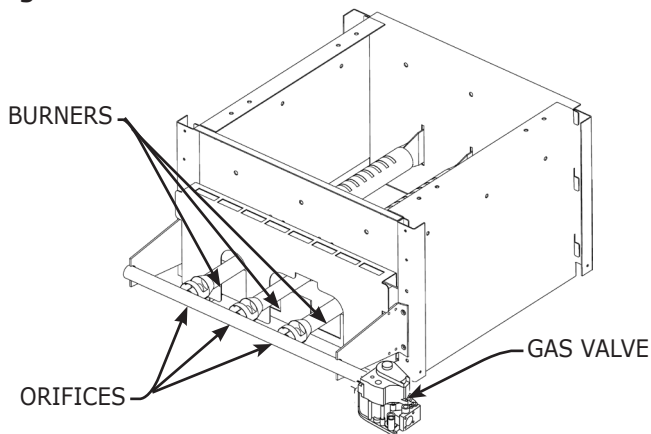
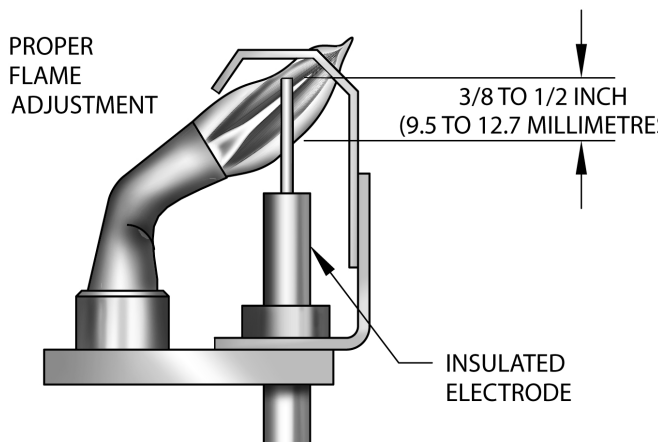



Figure 19 - Gas Burner Pilot



- » Make visual inspection of main burner and pilot flames at start of heating season and again in mid-season. Main burner flame should have well defined inner blue mantel with lighter blue outer mantel. Check burner throats and burner orifices for lint or dust obstruction. Figures 17 and 18.
- » Pilot flame should envelop $\frac{3}{8}$ to $\frac{1}{2}$ inch of tip of ignition/sensing electrode. See Figure 19.
- » To adjust pilot flame, remove pilot adjustment cover screw and turn inner adjustment screw counterclockwise  to increase or clockwise  to decrease pilot flame. Be sure to replace cover screw after adjustment to prevent possible gas leakage. See Figure 15, Page 18.
- » Check burners and pilot for signs of corrosion, rust or scale buildup.
- » Area around boiler must be kept clear and free of combustible materials, gasoline and other flammable vapors and liquids.
- » Free flow of combustion and ventilating air to boiler and boiler room must not be restricted or blocked.
- » Inspect field sourced low water cutoffs annually, or as recommended by low water cutoff manufacturer. Flush float type low water cutoffs per manufacturer's instructions.
- » Employ a qualified service agency to make annual inspection of boiler and heating system. They are experienced in making the inspections outlined above, and, in event repairs or corrections are necessary, trained technicians make the proper changes for safe operation of the boiler.

CHECKING GAS INPUT RATE TO BOILER

- » Adjust gas input to boiler by removing protective cap on pressure regulator, and turning screw clockwise ↻ to increase input and counterclockwise ↻ to decrease input.
- » Manifold pressures are taken at outlet side of gas valve.
- » To check for proper flow of natural gas to boiler, divide input rate shown on rating plate by heating value of gas obtained from local gas company. This determines number of cubic feet of gas required per hour.
- » With all other gas appliances off, determine flow of gas through meter for two minutes and multiply by 30 to get hourly rate.
- » Make minor adjustments to gas input as described above. See Figure 15 page 18.
- » Change burner orifices if final manifold pressure varies more than plus or minus 0.3 inches water column from specified pressure listed on boiler rating plate.
- » Primary air adjustment is not necessary, therefore air shutters are not furnished as standard equipment.

CHECK SAFETY CONTROL CIRCUIT. Test ignition system safety shutoff device after placing boiler in operation. Figure 16 page 19.

- 1. Intermittent Pilot:** With main burner operating, turn pilot gas adjusting screw clockwise ↻ until pilot gas is turned off. Within 90 seconds main gas control closes, shutting off gas to main burner.
- 2. High Limit Control:** Remove plastic cover and note temperature setting. Refer to appendix A for adjustment procedure. Decrease setting to minimum and operate boiler. When boiler water temperature exceeds control temperature setting, control will open circuit, closing automatic main gas valve. Figure 20.

Figure 20 - High Limit Control Location

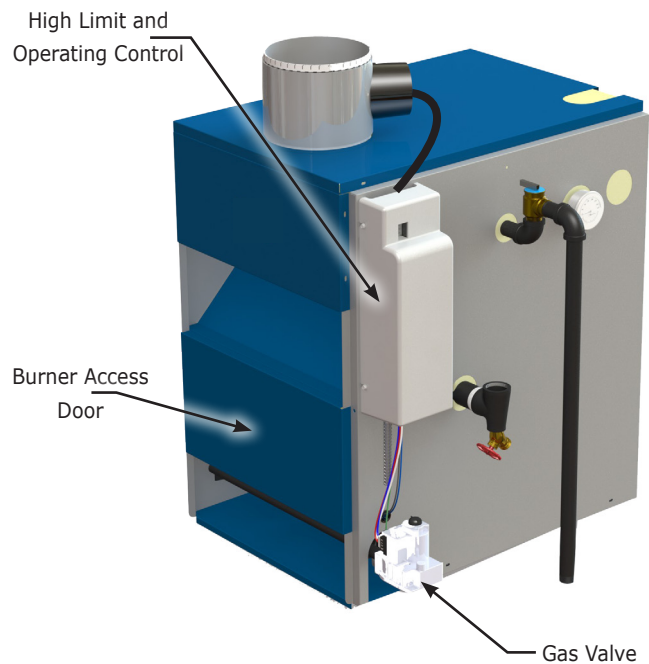

A.1 Installation Environment Considerations

⚠ WARNING

If you do not follow these instructions exactly, a fire or explosion may result causing property damage, personal injury or loss of life.

- » **Do not use this appliance if any part has been under water.** Immediately call a qualified service technician to inspect appliance and to replace any part of control system and any gas control which has been under water.
- » Do not allow water to drip on controls. Prevent condensation by allowing air circulation around module and gas control.
- » Do not use corrosive chemicals around or on module or gas control.

- » Controls can be damaged by excessively high temperatures. Verify adequate air circulation around control is maintained when installing boiler.

A.2 Electrical Connections

Connect Module Connectors Figure 13, Page 16

- » Connect L, N, G leads inside J box using wire nuts. Secure J-box cover.
- » Connect Circulator harness to circulator. Harness comes plugged into module with Molex[®] plug.
- » Connect thermostat connection to yellow wires marked TT using wire nuts.
- » Ensure remaining Molex[®] plug connectors have not worked loose during transit.
- » Check sensing bulb is fully inserted in well and is not loose.
- » Verify vent damper connection is made. See page 13.

A.3 Adjusting Settings

To discourage unauthorized changing of settings, procedure to enter adjustment mode is required.

To enter adjustment mode, press UP, DOWN, and I buttons simultaneously for three seconds. Press and release I button until parameter requiring adjustment is displayed. See Figure 21 below.

- o "SP_" Setpoint (180 °F default setting; adjustable between 130 and 220 °F). Note: on some models this is "HL" High Limit.
- o "Df_" Setpoint Differential (15 °F default setting; adjustable between 10 and 30 °F)
- o "°F_" Degrees Fahrenheit

Press UP or DOWN button until parameter has reached desired value. After 60 seconds without any button inputs, control automatically returns to READ mode.

A.4 Display

In RUN mode, status items and parameters are viewable.

Example, to display setpoint, control flashes "sp" (setpoint) followed by temperature (i.e., 135), followed by °F or °C.

To read settings, press and release I key to find parameter of interest.

Example, press and release I until setpoint (sp) is displayed, followed by three-digit number, i.e., 190, followed by °F or °C. Press I button again will display (S1T) Sensor 1 Temperature followed by three-digit number and corresponding degree designator.

See Display Readout.

Figure 21 - Display Readout

TEXT	DESCRIPTION	DISPLAY SHOWS
STA	STATUS (SEE STATUS NUMBERS)	StA
BT	BOILER TEMPERATURE	bT
SP	OPERATING SETPOINT	SP
HL	HIGH LIMIT SETPOINT	HL
HDF	DIFFERENTIAL SETPOINT	HdF
FLA	FLAME CURRENT	FLA
RUN	RUN TIME HOURS	run
CYC	BOILER CYCLES	CYC
ERR	ERROR (SEE ERROR NUMBERS)	Err

M33683

APPENDIX A - CONTROL MODULE

A.5 Operation

Module continuously monitors boiler water temperature and fires or shuts off burner based on this temperature data.

1. When "Call for Heat" occurs, control enables circulator and monitors boiler water temperature to determine whether thermostat can be satisfied without firing burners.
2. Control determines burner operation is required, module proceeds to start burner (see state codes list) and heats water in boiler until setpoint temperature is achieved or thermostat is satisfied. .
3. Burner is de-activated, ignition module completes heating cycle, returns to idle and waits for temperature to drop again.
4. Circulator is turned on throughout "Call for Heat."

Table 6 - Vent Damper Models Operation State Codes

1. State code sequence through a normal heat cycle			
Order	State Code Number	Definition	Explanation
a	1	Idle	There is no call for heat and or:
b	1	Circulator	Thermostat has call for heat. Control has activated system circulator pump and is waiting to see if there is enough heat to satisfy the thermostat without firing the burners. This may last as long as 2 minutes, but will typically be much less.
c	17	Diagnostics	Pilot valve diagnostics/current leakage detection. Typically a few seconds.
d	18	Wait for damper to open	Vent damper should be closed while boiler is off to conserve energy. Now, the vent damper must open before burner can safely be lit. The vent damper must confirm it is open (a switch closes to do this). The control is waiting for this to occur. This may last up to one minute. If the vent damper switch has not closed after one minute, ERR 55 will be displayed.
e	17	Diagnostics	Another diagnostic check. The control will also check the safety switches (rollout and vent) are closed. This will be so quick the control may move on before the STA code is flashed. Should the safety switches be detected open, the control will show STA15 for as long as the switches are open.
f	6	Spark	Spark for ignition. There should be an audible sparking (buzzing) noise. This will last until the control detects a pilot flame, but not more than 30 seconds (90 for S9361A2095). (If no flame is detected after the trial period, sparking will cease, and a 5 minute delay will occur before the control tries again. STA10 will be displayed during this period).
g	7	Flame stabilization	The pilot flame must be strong enough(1 μ A) for the control to release the main burners. This will last up to 10 seconds. (If the flame is still not strong enough after 10 seconds, the control will shut off the pilot, wait 5 minutes, then try again. STA10 will be displayed during the 5 minute period).
h	8	Running	Main burners are providing heat. This will continue as long as the thermostat requires. During this period, the control will monitor the pilot signal, boiler temperature, damper, and limit switches to assure safe operation.
g	1	Post operation	The damper will close again to conserve heat, and the circulator pumps will continue for a short time to deliver stored heat to the house before it has a chance to escape during the upcoming off period.

APPENDIX A - CONTROL MODULE

Table 6 conti. - Vent Damper Models Operation State Codes

Order	State Code Number	Definition	Explanation
2. Other possible state codes			
h	4	Pre-purge	System is purging before ignition trial; includes Pilot Valve circuit diagnostics. On vent damper models, this is so quick it will typically be over before the display can flash this code, and therefore will rarely be visible.
i	9	Post-purge	System is purging after heat cycle. On vent damper models, this is so quick it will typically be over before the display can flash this code, and therefore will rarely be visible.
j	10	Retry Recycle Delay	5 minute delay after pilot signal is lost. Either: 1. Control failed to detect flame after spark period. Check pilot for contamination, check ignition wire; check electrical ground; Check pilot flame. 2. Control lost pilot flame signal AFTER main burners were lit. Check for adequate draft and combustion air. Check gas line for adequate pressure.
k	13	Soft lock out	Soft lock out duration is one hour, may override with manual reset. Appropriate error code will flash alternately.
l	14	Hard lock out	Requires manual reset. Unacceptable high water temperature (err 65) and onboard electronics failure (er 18) are the only two (2) hard lockouts on this model.
m	15	Wait for limit to close	One of the safety limits - rollout, vent spill, or low water cutoff (if one is field installed on the 24V safety circuit) has been activated. Control will resume normal operation once limit is reset. Underlying cause why the limit switch opened MUST be investigated.
n	16	Flame out of sequence	Flame signal sensed before trial ignition. Appropriate alarm is sent. OR Flame signal sensed out of sequence during post purge OR Flame signal present when not expected. Appropriate alarm is sent.
o	17	Diagnostics	Onboard self check performed at various points during the operation sequence.
p	19	Wait for damper switch to close	Damper is closed and control waits for damper switch to close. Checked at beginning of heat cycle before opening damper. If damper does not open in 60 seconds, control goes to State 20. Control may also be in state 15 if one of the safety limits is open.
q	20	Wait for damper to open (Failed close)	Damper has not opened (end switch not closed) at beginning of heat cycle. Alarm message is sent, control is NOT in lockout. Control will resume normal operation once the damper opens.
r	21	Wait for damper to close (Failed open)	Damper has not closed despite actuator de-energized. Alarm message sent, control is NOT in lockout.

A.6 Boiler High Limit Temperature Controller

- » When water temperature reaches setpoint, controller ends heating cycle.
- » When water temperature drops below setpoint minus differential, controller restarts heat cycle to re-heat boiler water.
- » If water temperature exceeds maximum allowed temperature (220°F or 104°C), controller enters manual reset lockout state.
- » For models having reset capability, press any onboard button or cycle power to reset.

Figure 23 - Basic Control Algorithm Example

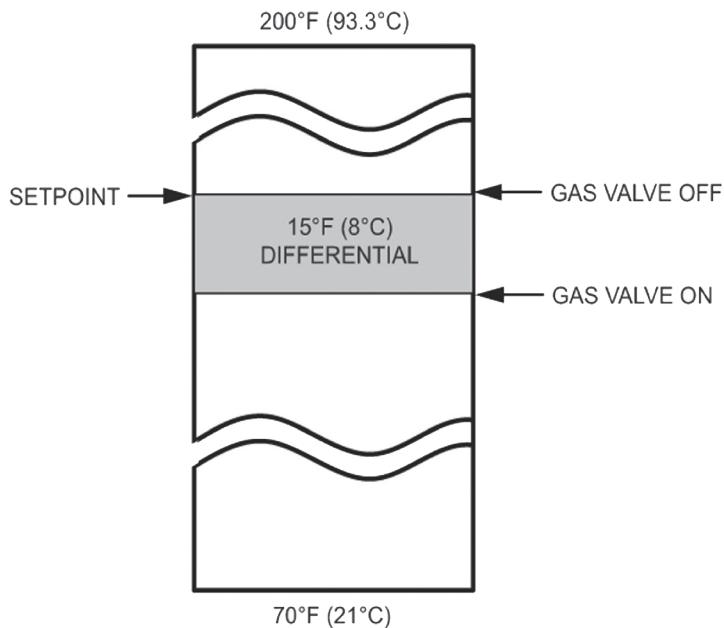

A.7 Troubleshooting

- » Following service procedures are provided as general guide.
- » On lockout and retry models, meter readings between gas control and ignition module must be taken within trial for ignition period. Once ignition module shuts off, lockout models must be reset through key buttons and display. On retry models, wait for retry or reset at thermostat.
- » Check for correct installation and wiring before replacing any component.
- » Control module cannot be repaired. If it malfunctions, it must be replaced.
- » Use only qualified service agent to service ignition systems.

1. Perform checkout as first step in troubleshooting. Check troubleshooting guide to pinpoint cause of problem. See Table 7 , page 26.
2. If troubleshooting indicates ignition problem, see Ignition System Checks to isolate and correct the problem.
3. Perform checkout procedure following troubleshooting guide again to verify system is operating normally.

A.8 Troubleshooting Error Codes

Integrated boiler control uses advanced diagnostic capability to assist in troubleshooting error conditions. Table 7 shows codes that could arise on integrated display during fault. Suggestions are provided in Table 6 page 23 and Table 7 page 26 for servicing these potential errors.

APPENDIX A - CONTROL MODULE

Table 7 - Troubleshooting Error Codes

Error Code Number	Definition	Error Display clearing (once error condition has disappeared)					Explanation	Things to look for
		Clears itself when root problem is solved	Cycle Power OFF	Push any key	Up/down key when status is displayed			
4	Flame current lower than threshold	*	*			Control requires a strong enough signal to verify flame is present. Signal too low.	<ol style="list-style-type: none"> 1. Check pilot flame sense is clean. 2. Check for proper ground 3. Check wiring 4. Check for correct pilot orifice 5. Check there are no gas leaks in pilot tubing 	
6	Flame sensed out of normal sequence		*			Control circuit is sensing flame rectification when there should be none.	<ol style="list-style-type: none"> 1. Check gas valve 2. Check all electrical connections are tight 	
18	Electronic failure			*	*	Control believes it is defective	<ol style="list-style-type: none"> 1. Try reset by cycling power or push any key 2. Check wiring to pilot and main valve 3. Control requires replacement 	
23	Flame sensed during Pre-purge		*			Primarily for induced draft models although present in vent damper software. Pilot is being sensed to soon in ignition sequence.	<ol style="list-style-type: none"> 1. Check gas valve 2. Check all electrical connections are tight 	
24	Flame sensed during Post-purge		*		*	Primarily for induced draft models although present in vent damper software. Pilot is being sensed to late in shutdown sequence.	<ol style="list-style-type: none"> 1. Check gas valve 2. Check all electrical connections are tight 	
32	Temperature sensor failure	*	*		*	Temperature sensor is not providing expected reading.	<ol style="list-style-type: none"> 1. Check sensor is plugged into control board 2. Check sensor wiring is not damaged 3. Scroll display reading to "bt" and hold sensor bulb securely in you hand. It should read a temperature close to body temperature. If not, replace sensor. 	
55	Damper end switch failed to close	*	*			Vent damper must confirm it is open (switch closes to do this). Control did not receive this signal after waiting one minute, and is still waiting.	<ol style="list-style-type: none"> 1. Check vent damper harness is securely connected to both vent damper and control board. 2. Check vent damper harness is not damaged. 3. Check vent damper mechanism is operating freely. 4. See Appendix B 	
56	Damper end switch failed to open	*	*			Vent damper must confirm it is closed (switch opens to do this) after a heat call. The control did not receive this signal after waiting one minute, and is still waiting.	<ol style="list-style-type: none"> 1. Check vent damper harness is connected to both vent damper and control board. 2. Check vent damper harness is not damaged. 3. Check vent damper mechanism is operating freely. 4. See Appendix B 	
57	Flame rod shorted to burner ground	*	*			Control did not detect a voltage difference between flame sense wire and ground.	<ol style="list-style-type: none"> 1. Check flame sense wire on pilot assembly is not frayed or damaged. If so, replace pilot assembly. <p><i>Note! These are high temperature wires. DO NOT attempt field repair.</i></p> <ol style="list-style-type: none"> 2. Check there is no moisture collecting on the control board. 	
58	AC line frequency error	*	*			AC frequency is incorrect or noisy.	<ol style="list-style-type: none"> 1. Some electric or electronic devices may generate electromagnetic interference. Verify none is present. 2. Check thermostat connection. 	

APPENDIX A - CONTROL MODULE

Table 7 - Troubleshooting Error Codes - conti.

Error Code Number	Definition	Error Display clearing (once error condition has disappeared)					Explanation	Things to look for
		Clears itself when root problem is solved	Cycle Power OFF	Push any key	Up/down key when status is displayed			
59	Line voltage error	*	*				Line voltage (or, possibly thermostat) is either too high or too low.	Source problem is likely in the electrical external to the boiler. Control will clear itself and resume normal operation once the situation is resolved. Check BOTH line power and thermostat wiring.
60	Thermostat input higher than threshold	*	*				Some types of thermostat may not be compatible with control circuitry.	Verify boiler works properly by jumping yellow thermostat wires. If so, replace thermostat (or thermostat wires).
61	Line Voltage unstable	*	*				Unstable line voltage - possibly to many heavy loads switching on and off.	<ol style="list-style-type: none"> 1. Check current draw on this branch circuit from house breaker box might have very heavy loads switching on or off. 2. Check power coming into the house. Source problem is likely in the electrical external to the boiler. Control will clear itself and resume normal operation once the situation is resolved.
62	Soft Lockout-Max retries exceeded		*	*			Control sensed consecutive instances of no flame signal while trying to light pilot. Note: not present on S9261A2095.	<ol style="list-style-type: none"> 1. Check control ground connection. 2. Check pilot ignition wire for good condition and connection. 3. Clean pilot tip. 4. Check pilot tube, assure no gas leaks. 5. Check correct pilot orifice is being used. 6. Check gas line pressure.
63	Soft Lockout - Max recycles exceeded		*	*			Control sensed consecutive instances of loss of pilot flame signal AFTER main burners are lit. Note: not present on S9261A2095.	<ol style="list-style-type: none"> 1. Check gas valve & gas supply. 2. Check all electrical connections are tight. 3. Check pilot rod is clean. 4. Check for adequate draft. 5. Check for adequate combustion air.
64	Soft Lockout - Internal failure		*	*			Control is sensing something wrong with electrical circuitry.	<ol style="list-style-type: none"> 1. Check all wiring is correct. Refer to wiring diagram. 2. Check there is a good ground to pilot bracket.
65	Hard Lockout - Temperature above limit		*	*			Control sensed water temperature too high for safe boiler operation	<ol style="list-style-type: none"> 1. Check water is circulating properly through boiler. 2. Check there is not air in the system. 3. If pressure relief valve is opened, there is definitely a problem with water circulation! 4. If any of the above 3 are true, root problem is in the hot water circulation. 5. Scroll display reading to "bt" , and hold sensor bulb securely in your hand. It should read a temperature close to body temperature. If not, replace sensor.

Note: In event of multiple errors, the highest error number is displayed first.

Note: Error codes 18 and 65 - Hard Lockout will not expire. Requires operator reset. No volatile memory (error will not be remembered if power is off).

Error codes 6, 23, 62,63 and 64 - Soft Lockout of 1 hour duration if not reset. Control will then resume normal operation. If source error is still present a second soft lockout is possible.

All other codes - No lockout. Control will resume normal operation immediately when source error is resolved.

A.9 Intermittent Pilot

Ignition System Checks

STEP 1: Check ignition cable.

- » Verify ignition cable does not make contact with metal surfaces.
- » Verify only factory supplied Ignition cable (or approved replacement) is used.
- » Verify connections to ignition module and igniter or igniter-sensor are clean and tight.
- » Verify ignition cable provides good electrical continuity.

STEP 2:

Verify ignition system grounding. Nuisance shutdowns are often caused by poor or erratic grounding.

Common ground is required for module and pilot burner/igniter sensor.

- Check for good metal-to-metal contact between pilot burner bracket and the main burner.
- Check ground lead from GND (BURNER) terminal on module to pilot burner. Verify connections are clean and tight. If wire is damaged or deteriorated, replace with No. 14-18 gauge, moisture-resistant, thermoplastic insulated wire with 105°C [221°F] minimum rating.
- Check ceramic flame rod insulator for cracks or evidence of exposure to extreme heat, which can permit leakage to ground. Replace pilot burner/igniter sensor and provide shield if necessary.
- If flame rod or bracket is bent out of position, restore to correct position.

STEP 3: Check spark ignition circuit.

Disconnect ignition cable at SPARK terminal on module.

 WARNING
<p>Electrical shock hazard. Ignition circuit generates over 10,000 volts. Turn OFF electrical power supply at service panel before making electrical connections. Failure to do so could result in death or serious injury.</p>

Energize module and listen for audible sparking noise. When operating normally, there should be a buzzing noise that turns on and off twice per second for duration of 1-7 seconds depending on model.





STEP 4: Verify pilot and main burner lightoff.

- » Initiate call for heat. Turn thermostat above room temperature. Ignition sequence may be delayed by thermal purge up to 2 minutes.
- » Watch pilot burner during ignition sequence.
 - Verify ignition spark continues after pilot is lit.
 - Verify pilot lights and spark stops, verify main burner does not light.
- » If so, ensure adequate flame current as follows.
 - Turn off boiler at circuit breaker or fuse box.
 - Clean flame rod with emery cloth.
 - Verify electrical connections are clean and tight. Replace damaged wire.
 - Check for cracked ceramic insulator, which can cause short to ground, and replace igniter-sensor if necessary.
 - At gas valve, disconnect main valve wire from MV terminal.
 - Turn on power and set thermostat to call for heat. Pilot should light, main burner will remain off because main valve actuator is disconnected.
 - Check pilot flame. Verify it is blue, steady and envelops 3/8 to 1/2 in. [10 to 13 mm] of flame rod. See Figure 24 for possible flame problems and causes.
 - If necessary, adjust pilot flame by turning pilot adjustment screw on gas control clockwise to decrease or counterclockwise to increase pilot flame. Following adjustment, always replace pilot adjustment cover screw and tighten firmly to assure proper gas control operation. Figure 19, page 20.
 - Set temperature below room set-point to end call for heat.

» Recheck ignition sequence as follows.

- Reconnect main valve wire.
- Adjust thermostat above room temperature.
- Verify ignition sequence at burner.
- If spark does not stop after pilot lights, replace module.
- If main burner does not light or if main burner lights and system locks out, check module, ground wire and gas control as described in troubleshooting table. See Table 7, Page 26.

Figure 24 - Troubleshooting Pilot Flame

APPEARANCE	CAUSE
<p>SMALL BLUE FLAME</p> 	<p>CHECK FOR LACK OF GAS FROM:</p> <ul style="list-style-type: none"> • CLOGGED ORIFICE FILTER • CLOGGED PILOT FILTER • LOW GAS SUPPLY PRESSURE • PILOT ADJUSTMENT AT MINIMUM
<p>LAZY YELLOW FLAME</p> 	<p>CHECK FOR LACK OF AIR FROM:</p> <ul style="list-style-type: none"> • DIRTY ORIFICE • DIRTY LINT SCREEN, IF USED • DIRTY PRIMARY AIR OPENING, IF THERE IS ONE • PILOT ADJUSTMENT AT MINIMUM
<p>WAVING BLUE FLAME</p> 	<p>CHECK FOR:</p> <ul style="list-style-type: none"> • EXCESSIVE DRAFT AT PILOT LOCATION • RECIRCULATING PRODUCTS OF COMBUSTION
<p>NOISY LIFTING BLOWING FLAME</p> 	<p>CHECK FOR:</p> <ul style="list-style-type: none"> • HIGH GAS PRESSURE
<p>HARD SHARP FLAME</p> 	<p>THIS FLAME IS CHARACTERISTIC OF MANUFACTURED GAS</p> <p>CHECK FOR:</p> <ul style="list-style-type: none"> • HIGH GAS PRESSURE • ORIFICE TOO SMALL

Correct Pilot Flame: 3/8 to 1/2 inch in flame. See Figure 20, Page 20.

B.1 Vent Damper Harness - Molex Plugs

⚠ WARNING

Do Not negate the action of any existing safety operational controls. Avoidance of these instructions could result in death or serious injury.

Note

When servicing controls, all wires must be labeled prior to disconnection. Wiring errors can cause improper and dangerous operation. Do not turn damper open manually or motor damage will result and void all warranties, use the service switch.

DO NOT CUT PLUG OFF OF DAMPER MOTOR ASSEMBLY OR WARRANTY WILL BE VOID.

Check Molex Plugs on Vent Damper Harness:

Note

Damper wiring harness is made up of 4 individual colored wires, Brown, Black, Yellow, and Orange (refer to drawing below).

1. Disconnect thermostat wires.
2. Use the two diagrams below to confirm the Molex plugs on each end of the damper harness are wired and operating properly.

Damper end of wiring harness:

- A. Hold plug in hand with wiring harness behind Molex with "V" slot on top. Verify wire colors are in proper position.
 - B. Take reading across brown and black wires in Molex plug, using test meter set for AC volts. 24 volts should be present.
 - i. IF NOT, source of the problem is not in damper; check line voltage and 24 volt supply.
 - ii. If 24 volts is present across brown and black, continue to step iii.
 - iii. Reconnect thermostat wires and turn up heat setting.
 - iv. Check voltage across black and orange wires in Molex plug. 24 volts AC should be present:
 - » IF NOT, source problem is not the damper.
 - » If 24 volts is present continue on to step v.
 - v. Place jumper wire across orange and yellow wires in Molex plug (see Below). This will create bypass of the damper, boiler should then ignite.
- »IF NOT, source problem is not the damper. Go to "Aquastat end of wiring harness"

»If boiler ignites: Go to section B.2 "Vent Damper Troubleshooting Guide".
NOTE: Prior to replacing the damper, be sure the problem is not with wire connections between damper and wiring harness.

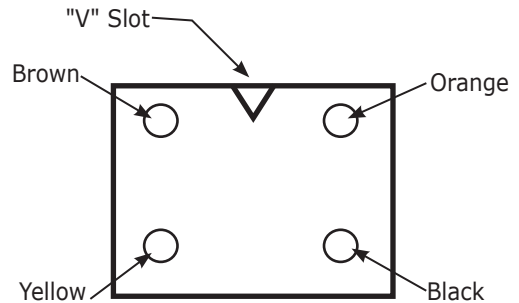

Control End of wiring harness

Hold plug in hand with wiring harness behind Molex with "V" slot on top. Verify wires colors are in proper position

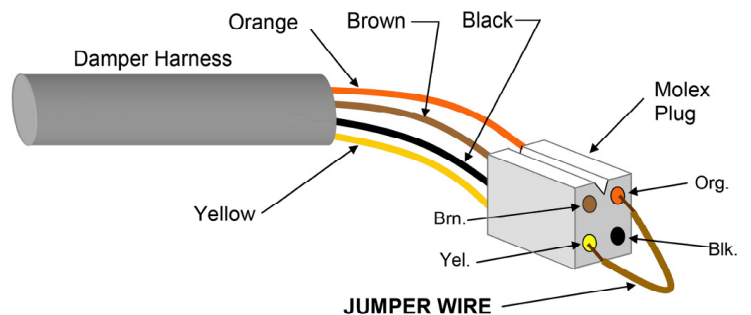
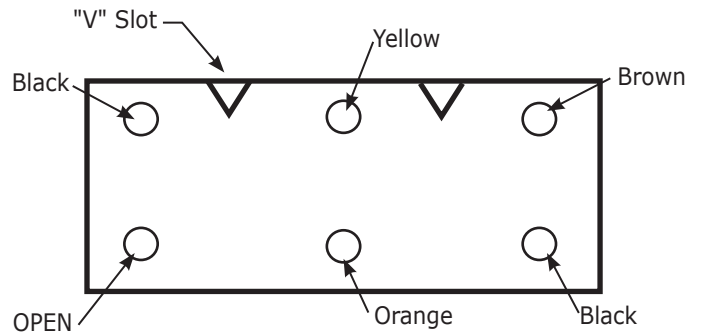

- A. Remove damper harness from control. Jump Molex connector on control board between two center holes using ~18ga. thermostat wire.
 - i. If boiler ignites, replace damper harness
 - ii. If boiler does not light, replace control.

B.2 Vent Damper Troubleshooting Guide

⚠ WARNING

Do Not negate the action of any existing safety operational controls. Avoidance of these instructions could result in death or serious injury.

Note

When servicing controls, all wires must be labeled prior to disconnection. Wiring errors can cause improper and dangerous operation. Do not turn damper open manually or motor damage will result and void all warranties, use the service switch.

DO NOT CUT PLUG OFF OF DAMPER MOTOR ASSEMBLY OR WARRANTY WILL BE VOID.

Normal Sequence of Operation

24 VAC Power	Power ON	Damper Position
4 & 1	All times	Open or Closed
4 & 2	Calling for Heat	Open or Opening
4 & 3	During combustion	Damper Open



Trouble Shooting

Problem	Possible Cause	Recommended Solution
NO POWER Between 4 & 1	<ol style="list-style-type: none"> Off on limit (120VAC) Bad transformer Loose or broken connections Blown fuse or circuit breaker Disconnect switch off Harness not plugged into receptacle 	<ol style="list-style-type: none"> turn limit on Replace transformer Tighten, repair, or replace connection Replace fuse or reset circuit breaker Turn switch on Plug harness in
NO POWER Between 4 & 2 POWER Between 4 & 1 When calling for heat	<ol style="list-style-type: none"> Thermostat not calling for heat Burned out heat anticipator Loose or broken connections Off/On operating limit, or low water cut off Off/On blocked vent switch or flame roll out 	<ol style="list-style-type: none"> Turn thermostat up to call for heat Replace thermostat Tighten, repair, or replace connection Turn operating limit, or low water cutoff ON Reset or replace switch
POWER Between 4 & 1 Between 4 & 2 DAMPER OPEN	<ol style="list-style-type: none"> Loose or broken connection Defective damper motor 	<ol style="list-style-type: none"> Tighten, repair, or replace connection Replace damper motor assembly

APPENDIX B - VENT DAMPER TROUBLESHOOTING

Note

For troubleshooting only. Verify damper is in open position. Use service switch to keep damper in open position. Place jumper between 2 & 3. If appliance fires, remove jumper and plug receptacle back into damper controller plug. If appliance does not fire, replace damper motor assembly. Do not replace pipe assembly.

If damper motor assembly is not available, place service switch in hold open position. This should keep damper in open position and allow customer to have automatic heat. Return or replace the motor assembly at your convenience. Motor assembly carries 18 month limited commercial warranty from the original date of purchase. (Refer to form #4294 on website). Pipe assembly is not warranted.

Trouble Shooting with Jumper Wire In Place

Problem	Possible Cause	Recommended Solution
NO POWER Between 4 & 1 Between 4 & 2 Between 4 & 3 Damper OPEN NO COMBUSTION	<ol style="list-style-type: none"> 1. Is gas turned on 2. Operating limit, pressure control, low water cut off not on. 3. Blocked vent switch or flame roll out switch tripped 4. Loose or broken connection 5. Defective component in appliance after vent damper 	<ol style="list-style-type: none"> 1. Verify gas is on 2. Verify operating limit, pressure control or low water cut off is on 3. Reset or replace blocked vent switch or flame roll out switch 4. Tighten, repair, or replace connection 5. Replace defective component in appliance
Damper Sticks	<ol style="list-style-type: none"> 1. Damper blade obstruction 2. Damper pipe egg shaped, out of round/binding. 3. Crimped end of vent piece inserted in to far 	<ol style="list-style-type: none"> 1. Clear the obstruction 2. Restore to damper pipe to round, verify not binding. 3. Correct the condition
Damper Rotates Continuously	<ol style="list-style-type: none"> 1. Defective damper motor assembly 	<ol style="list-style-type: none"> 1. Replace damper motor assembly

IMPORTANT

In accordance with Section 325 (f) (3) of the Energy Policy and Conservation Act, this boiler is equipped with a feature that saves energy by reducing the boiler water temperature as the heating load decreases. This feature is equipped with an override which is provided primarily to permit the use of an external energy management system that serves the same function.

THIS OVERRIDE MUST NOT BE USED UNLESS AT LEAST ONE OF THE FOLLOWING CONDITIONS IS TRUE:

- » An external energy management system is installed that reduces the boiler water temperature as the heating load decreases.
- » This boiler is not used for any space heating
- » This boiler is part of a modular or multiple boiler system having a total input of 300,000 BTU/hr or greater.
- » This boiler is equipped with a tankless coil.



UTICA BOILERS
2201 Dwyer Avenue
Utica NY 13501

web site: www.ecrinternational.com

P/N 240011584 Rev. A [07/30/2016]