



Models
MGC-8D
MGC-8DP
MGC-9D
MGC-9DP

MGC
GAS-FIRED
HOT WATER BOILERS
with Honeywell Control

**INSTALLATION, OPERATION &
MAINTENANCE MANUAL**



C.S.A. Certified
For Natural Gas Or Propane

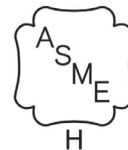

Tested For 50 psi.
ASME
Working Pressure



ECR international
EST. 1928
A Family of Heating & Cooling Brands.

Manufactured by:

ECR International, Inc.
2201 Dwyer Avenue, Utica NY 13501
web site: www.ecrinternational.com

P/N 240011611 Rev. A [08/31/2016]

1 - DIMENSIONS

Figure 1 - Dimensions

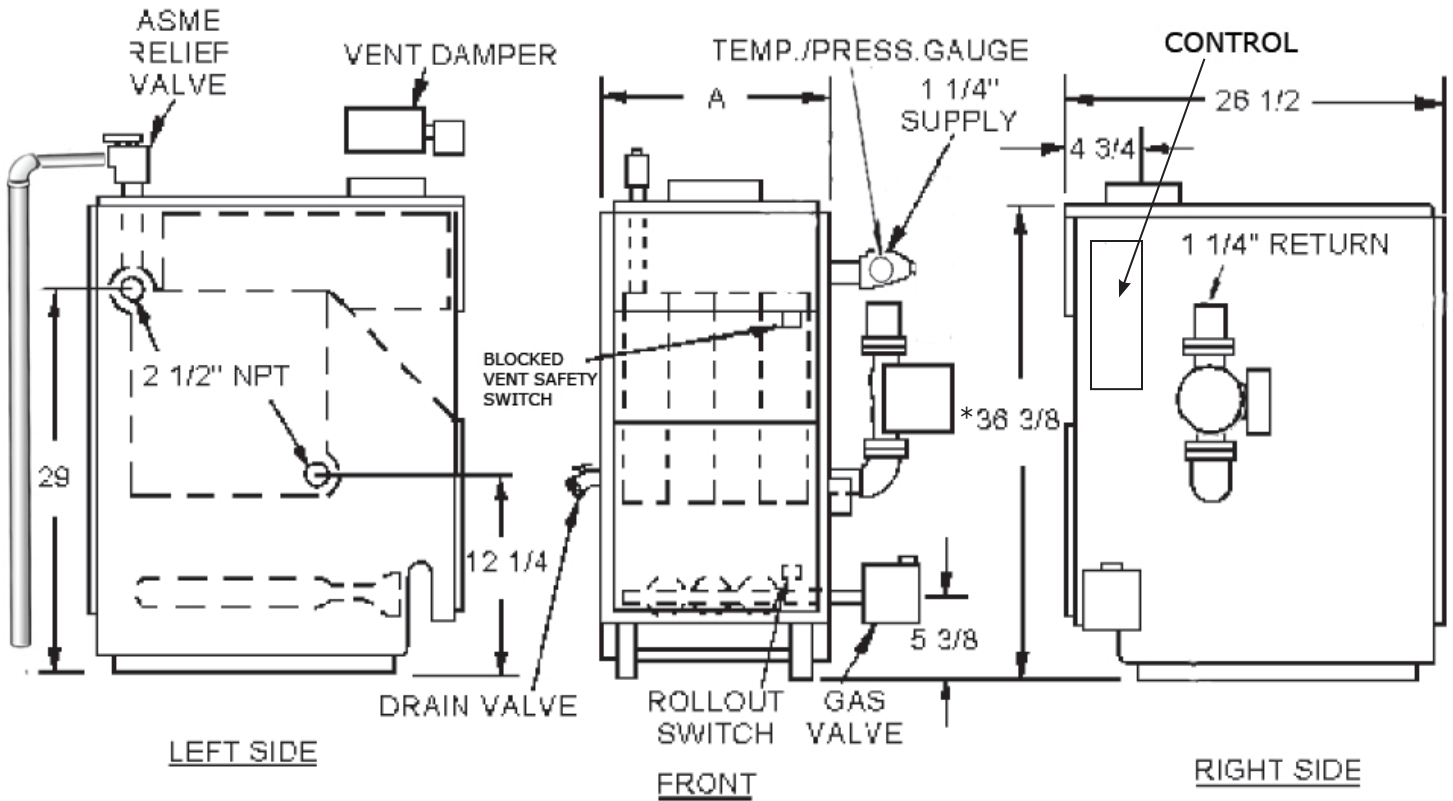

* Minimum acceptable height for Low Water Cutoff probe.

Table 1 - Dimensions		
BOILER MODEL NUMBER	DIMENSIONS (INCH.)	
	FLUE DIAMETER	"A" WIDTH
MGC-8	7	27½
MGC-9	7	30¾
Add 5½" to height for vent Damper.		

3 - TABLE OF CONTENTS

1 - Dimensions.....	2
2 - Ratings And Capacities	3
3 - Table of Contents.....	4
4 - Installation Procedure	5
5 - Ventilation & Combustion Air	6
6 - Connecting Supply And Return Piping	7
7 - Chimney And Vent Pipe Connection	11
8 - Vent Damper Operation	14
9 - Gas Supply Piping.....	15
10 - Electrical Wiring.....	15
11 - Wiring Diagrams	16
12 - General Instructions.....	19
13 - Lighting Instructions	20
14 - Operating Your Boiler	21
15 - Service Hints.....	22
16 - Maintaining Your Boiler	23
Appendix A - Control Module	24
Appendix B - Vent Damper.....	32

SAFETY SYMBOLS & WARNINGS

The following defined symbols are used throughout this manual to notify the reader of potential hazards of varying risk levels.

DANGER

Indicates a hazardous situation which, if not avoided, WILL result in death or serious injury

WARNING

Indicates a hazardous situation which, if not avoided, could result in death or serious injury.

CAUTION

Indicates a hazardous situation which, if not avoided, could result in minor or moderate injury.

NOTICE

Used to address practices not related to personal injury.

**KEEP THIS MANUAL NEAR BOILER
RETAIN FOR FUTURE REFERENCE**

**IMPORTANT: Read the following instructions
COMPLETELY before installing!!**

WARNING

Fire, explosion, asphyxiation and electrical shock hazard. Improper installation could result in death or serious injury. Read this manual and understand all requirements before beginning installation.

WARNING

Keep boiler area clear and free from combustible materials, gasoline and other flammable vapors and liquids.
DO NOT obstruct air openings to the boiler room. Modification, substitution or elimination of factory equipped, supplied or specified components may result in personal injury or loss of life.
TO THE OWNER - Installation and service of this boiler must be performed by a qualified installer.
TO THE INSTALLER - Leave all instructions with boiler for future reference.
When this product is installed in the Commonwealth of Massachusetts the installation must be performed by a Licensed Plumber or Licensed Gas Fitter.

CAUTION

Laceration, burn hazard. Metal edges and parts may have sharp edges and/or hot. Use appropriate personal protection equipment to include safety glasses and gloves when installing or servicing this boiler. Failure to follow these instructions could result in minor or moderate injury.

2 - BOILER RATINGS AND CAPACITIES

 Table 2 - Ratings and Capacities							
BOILER MODEL NUMBER ⁽¹⁾	† NATURAL GAS			† PROPANE GAS			AFUE
	Input ⁽³⁾ Mbh	⁽¹⁾ Heating Capacity ⁽³⁾ Mbh	⁽²⁾ NET AHRI RATING Water, ⁽³⁾ Mbh	INPUT ⁽³⁾ MBH	HEATING CAPACITY ⁽³⁾ MBH	NET AHRI RATING	INTERMITTENT IGNITION WITH VENT DAMPER
MGC-8	262.5	220	191	245	206	179	83.9
MGC-9	299	251	218	280	235	204	83.7

† Input rating for sea level to 2,000 ft. (610m) above sea level.

- **United States**, over 2000 ft (610m) above sea level. Reduce input rate 4% for every 1000 ft (304m) above sea level.
- ***Canada**, 2000 ft (610m) to 4500 (1350m) above sea level, reduce input per table. Over 4500 ft (1350m) above sea level. Contact Provincial authority having jurisdiction.

+ Heating Capacity based on D.O.E. (Department of Energy) test procedure.

⁽¹⁾ Add model number suffice 'P' for Propane.

⁽²⁾ Net AHRI Water rating shown based on piping and pickup allowance of 1.15. Consult manufacturer before selecting boiler for installations having unusual piping and pickup requirements, such as intermittent system operation, extensive piping systems, etc.

⁽³⁾ Mbh = 1,000 Btuh = British Thermal Unit Per Hour

- Ratings marked "Net AHRI Ratings" indicate amount of remaining heat input used to heat radiation or terminal units. Net AHRI Ratings shown are based on allowance of 1.15 in accordance with factors shown on AHRI Standard as published by The Hydronics Institute.
- Selection of boiler size should be based upon "Net AHRI Rating" being equal to or greater than calculated heat loss of the building.
- Consult manufacturer before selecting boiler for installations having unusual piping and pickup requirements.

BOILERS FOR USE AT HIGH ALTITUDE

Boiler is factory equipped for use at altitudes of 0-2,000 feet above sea level.

For use at altitudes above 2,000 feet above sea level, input ratings are reduced by change in main burner orifice size.

For altitudes above 2,000 feet above sea level, input ratings should be reduced at rate of 4% for each 1,000 feet above sea level. Consult National Fuel Gas Code, ANSI Z223.1/NFPA 54, or manufacturer for correct orifice sizing information.

In Canada, a high altitude conversion kit is available to convert to altitudes of 2,000 to 4,500 feet above sea level. Please consult your dealer.

4 - INSTALLATION PROCEDURE

⚠ WARNING

Improper installation, adjustment, alteration, service or maintenance could result in death or serious injury.

1. Installation must conform to the requirements of the authority having jurisdiction or, in the absence of such requirements, to the National Fuel Gas Code, ANSI Z223.1/NFPA 54, and/or Natural Gas and Propane Installation Code, CAN/CSA B149.1.
2. Where required by the authority having jurisdiction, the installation must conform to the Standard for Controls and Safety Devices for Automatically fired Boilers, ANSI/ASME CSD-1.
3. Boiler series is classified as a Category I. Vent installation shall be in accordance with "Venting of Equipment," of the National Fuel Gas Code, ANSI Z223.1/NFPA 54, or "Venting Systems and Air Supply for Appliances," of the Natural Gas and Propane Installation Code, CAN/CSA B149.1, or applicable provisions of the local building codes.
4. Boiler has met safe lighting and other performance criteria with the gas manifold and control assembly on the boiler per the latest revision of ANSI Z21.13/CGA 4.9.
5. Install boiler such that gas ignition system components are protected from water (dripping, spraying, rain, etc.) during appliance operation and service, (circulator replacement, condensate trap, control replacement, etc.).
6. Locate boiler on level, solid base as near chimney as possible and centrally located with respect to heat distribution system as practical.
7. Allow 24 inches (610mm) at front and right side for servicing and cleaning.
8. When installed in utility room, door should be wide enough to allow largest boiler part to enter, or to permit replacement of another appliance such as water heater.

⚠ WARNING

Fire hazard. Do not install boiler on combustible flooring or carpeting. Failure to follow these instructions could result in death or serious injury.

1. **FOR INSTALLATION ON NON-COMBUSTIBLE FLOORS ONLY** - For installation on combustible flooring special base must be used. (See Replacement Parts Section.) **Boiler shall not be installed on carpeting.**

Table 3 - MINIMUM CLEARANCE DIMENSIONS

	Inches	(mm)
Top	6"	(152mm)
Rear	6"	(152mm)
Control Side	7"	(178mm)
Opposite Side	6"	(152mm)
Front	18"	(457mm)
Flue/Vent Connector	6"	(152mm)
Near Boiler Piping	1/2"	(13mm)

NOTE: Greater clearances for access should supersede fire protection clearances.

* Definition of Alcove is three sided space with no wall in front of boiler. ANSI standard for alcove is 18 inches from front of appliance to leading edge of side walls as shown below.

Minimum Clearances to Combustible Construction (as seen from above)

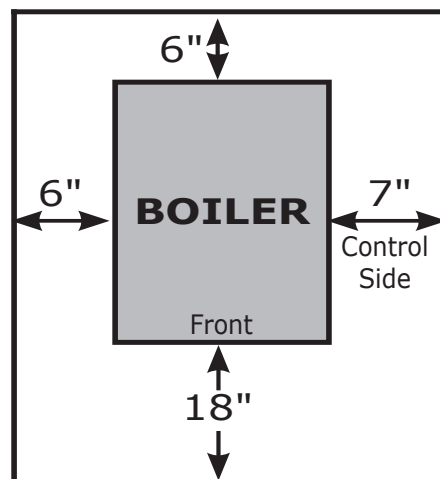

5 - VENTILATION & COMBUSTION AIR

Provide combustion air and ventilation air in accordance with the section "Air for Combustion and Ventilation," of the National Fuel Gas Code, ANSI Z223.1/NFPA 54, or Sections 8.2, 8.3 or 8.4 of Natural Gas and Propane Installation Code, CAN/CSA B149.1, or applicable provisions of local building codes.

Provide make-up air where exhaust fans, clothes dryers, and kitchen ventilation equipment interfere with proper operation.

National Fuel Gas Code recognizes several methods of obtaining adequate ventilation and combustion air. Requirements of the authority having jurisdiction may override these methods.

- Engineered Installations. Must be approved by authority having jurisdiction.
- Mechanical Air Supply. Provide minimum of 0.35 cfm per Mbh for all appliances located within space. Additional requirements where exhaust fans installed. Interlock each appliance to mechanical air supply system to prevent main burner operation when mechanical air supply system not operating.

- All Indoor Air. Calculate minimum allowable room volume for all appliances in space. Use a different method if minimum volume not available.
 - A. Standard Method. Cannot be used if known air infiltration rate is less than 0.40 air changes per hour. See Table 4 for space with boiler only. Use equation for multiple appliances.

$$\text{Volume} \geq 50 \text{ ft}^3 \times \text{Total Input [Mbh]}$$

- B. Known Air Infiltration Rate. See Table 4 for space with boiler only. Use equation for multiple appliances. Do not use an air infiltration rate (ACH) greater than 0.60.

$$\text{Volume} \geq 21 \text{ ft}^3/\text{ACH} \times \text{Total Input [Mbh]}$$

- C. Refer to National Fuel Gas Code for opening requirements between connected indoor spaces.

- All Outdoor Air. Provide permanent opening(s) communicating directly or by ducts with outdoors.
 - A. Two Permanent Opening Method. Provide opening commencing within 12 inches of top and second opening commencing within 12 inches of bottom of enclosure.
 - Direct communication with outdoors or communicating through vertical ducts. Provide minimum free area of 1 in² per 4 Mbh of total input rating of all appliances in enclosure.
 - Communicating through horizontal ducts. Provide minimum free area of 1 in² per 2 Mbh of total input rating of all appliances in enclosure.
 - B. One Permanent Opening Method. Provide opening commencing within 12 inches of top of enclosure. Provide minimum clearance of 1 inch on sides/back and 6 inches on front of boiler (does not supersede clearance to combustible materials).
- Refer to National Fuel Gas Code for additional requirements for louvers, grilles, screens and air ducts.
- Combination Indoor and Outdoor Air. Refer to National Fuel Gas Code for application information.

National Gas and Propane Installation Code Requires providing air supply in accordance with:

- Section 8.2 and 8.3 when combination of appliances has a total input of up to and including 400 Mbh (120 kW).
- Section 8.4 when combination of appliances has total input exceeding 400 Mbh (120 kW).
- Refer to Natural Gas and Propane Installation Code for specific air supply requirements for enclosure or structure where boiler is installed, including air supply openings and ducts.

Table 4 - Minimum Room Volume, Indoor Air Only*							
		Room Cubic Feet Volume					
Input Mbh	Standard Method	Known Air Infiltration Rate Method (Air Changes Per Hour)					
		0.1	0.2	0.3	0.4	0.5	0.6
262.5	13125	55125	27563	18375	13781	11025	9188
299	14950	62790	31395	20930	15698	12558	10465

* Table values based on boiler only. Add volume for any additional appliances.

⚠ WARNING

Burn and scald hazard. Safety relief valve could discharge steam or hot water during operation. Install discharge piping per these instructions.

1. Refer to local codes and appropriate ASME Boiler and Pressure Vessel Code for additional installation requirements. Install safety relief valve using pipe fittings provided with boiler. See Figure 2
2. Install safety relief valve with spindle in vertical position.
3. Do not install shutoff valve between boiler and safety relief valve.
4. Install discharge piping from safety relief valve. See Figure 2.
 - Use ¾" or larger pipe.
 - Use pipe suitable for temperatures of 375°F (191°C) or greater.
 - Individual boiler discharge piping shall be independent of other discharge piping.
 - Size and arrange discharge piping to avoid reducing safety relief valve relieving capacity below minimum relief valve capacity stated on rating plate.
 - Run pipe as short and straight as possible to location protecting user from scalding and properly drain piping.
 - Install union, if used, close to safety relief valve outlet.
 - Install elbow(s), if used, close to safety relief valve outlet and downstream of union (if used).
 - Terminate pipe with plain end (not threaded).

Figure 2 - Safety Relief Valve

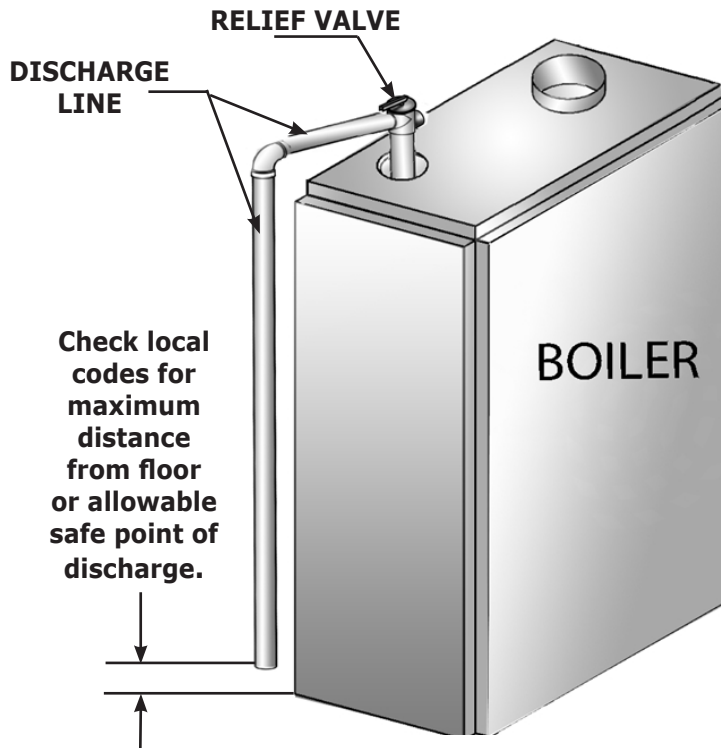

6 - CONNECTING SUPPLY AND RETURN PIPING

⚠ WARNING

Burn and scald hazard. Safety relief valve could discharge steam or hot water during operation. Install discharge piping per these instructions.

1. Boiler is shipped assembled. Install discharge piping from safety relief valve. See Warning, Page 7.
2. Install temperature pressure gauge.
 - Apply pipe sealant to threads on shaft of gauge.
 - Thread gauge into supply water tee. See Figure 3.

NOTICE

DO NOT TIGHTEN GAUGE BY HAND!! Gauge should be tightened using crescent wrench or 9/16" open end wrench. See Figure 3.

3. Connect supply and return lines to boiler. Connections may require additional fittings and parts, as shown on diagrams.

Verify clean water supply is available to water inlet valve. Install sand strainer when water supply is from a well or pump.

Install hot water boiler above radiation level or as required by Authority having jurisdiction install low water cutoff device at time of installation. See Figure 1 for minimum probe height. Use kit #550002998. follow instruction enclosed with kit. With other LWCO's use their manufacturer specific instructions.

Periodic inspection is necessary, as is flushing of float type devices, per manufacturers specific instruction.

FOR USE WITH COOLING UNITS

- A. Boiler used in connection with refrigeration system, must be installed so that chilled medium is piped in parallel with heating boiler. Appropriate valves must be used to prevent chilled medium from entering heating boiler. See Figure 5 page 9.
- B. Boiler connected to heating coils located in air handling units where they may be exposed to refrigerated air circulation, piping system shall be equipped with flow control valves or other automatic means to prevent gravity circulation of boiler water during cooling cycle.

LOW WATER TEMPERATURE AND LARGE WATER CONTENT SYSTEM (See Figures 6 and 7, Page 10.)

Significant condensation may form in boiler and/or venting system if boiler is operated for long period of time with return temperatures of less than 120° F.

Condensate is corrosive and can cause severe damage to boiler and venting system. Minimum design return water temperature to prevent condensation in boiler and venting is 120°F. Minimum high limit setting is 140°F.

1. Boiler used in heating system where design water temperatures below 140°F are desired (e.g. radiant floor heating), 4-way mixing valve or suitable alternative is required to prevent low temperature return water from entering boiler. Follow mixing valve manufacturer's instructions.
2. Boiler connected to system having large water content (such as former gravity system), install system bypass. See Figures 6 and 7, page 10.
3. If boiler water reset control is used to operate boiler, minimum reset supply water temperature setpoint must be at least 140°F, unless mixing valve is used as in (1) above.

Figure 3 - Temperature Pressure Gauge

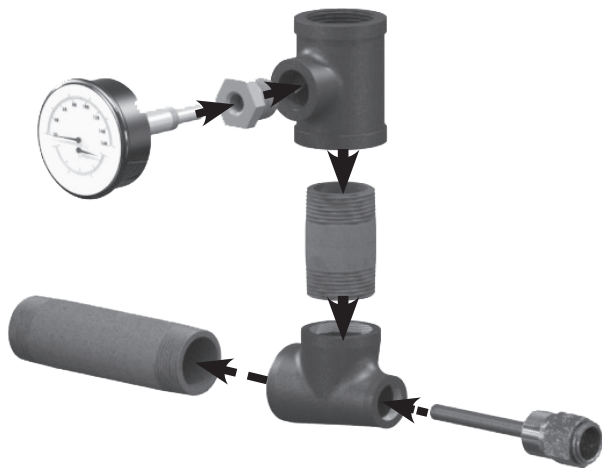

Figure 4 - Typical Hot Water Piping

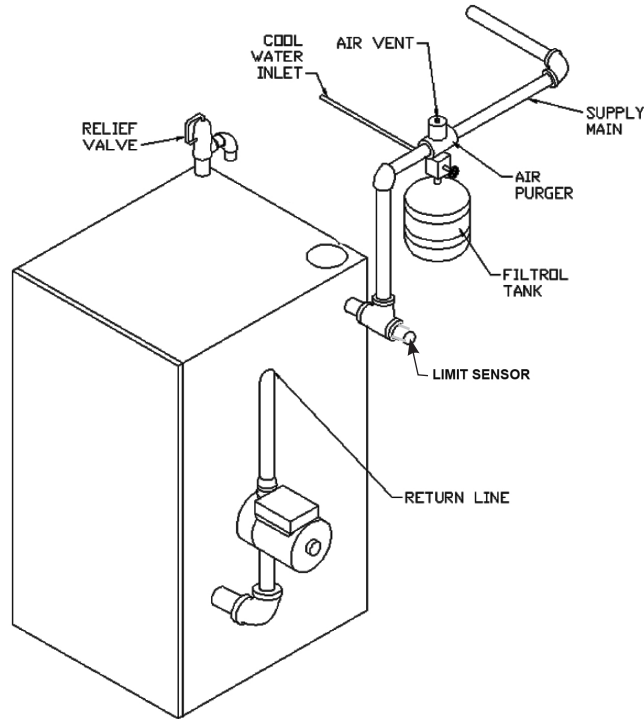
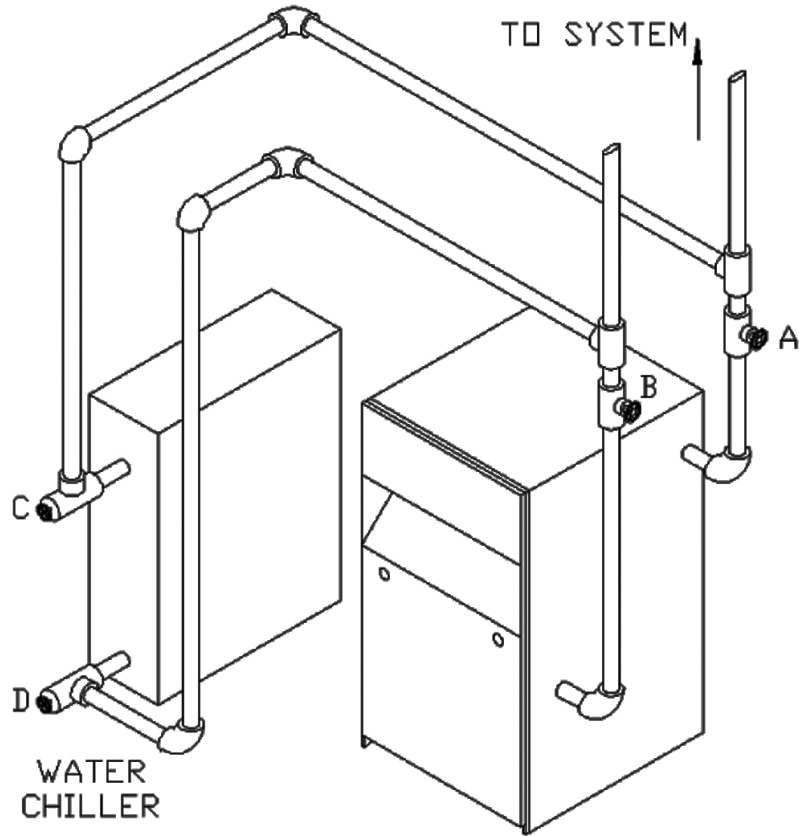

Figure 5 - Chilled Water Piping

VALVES A & B
OPEN FOR HEATING;
CLOSE FOR COOLING

VALVES C & D
CLOSE FOR HEATING;
OPEN FOR COOLING



6 - CONNECTING SUPPLY AND RETURN PIPING

Bypass Piping Required For High Mass (Large Water Content) Systems

Figure 6 - BYPASS PIPING - CIRCULATOR ON SUPPLY

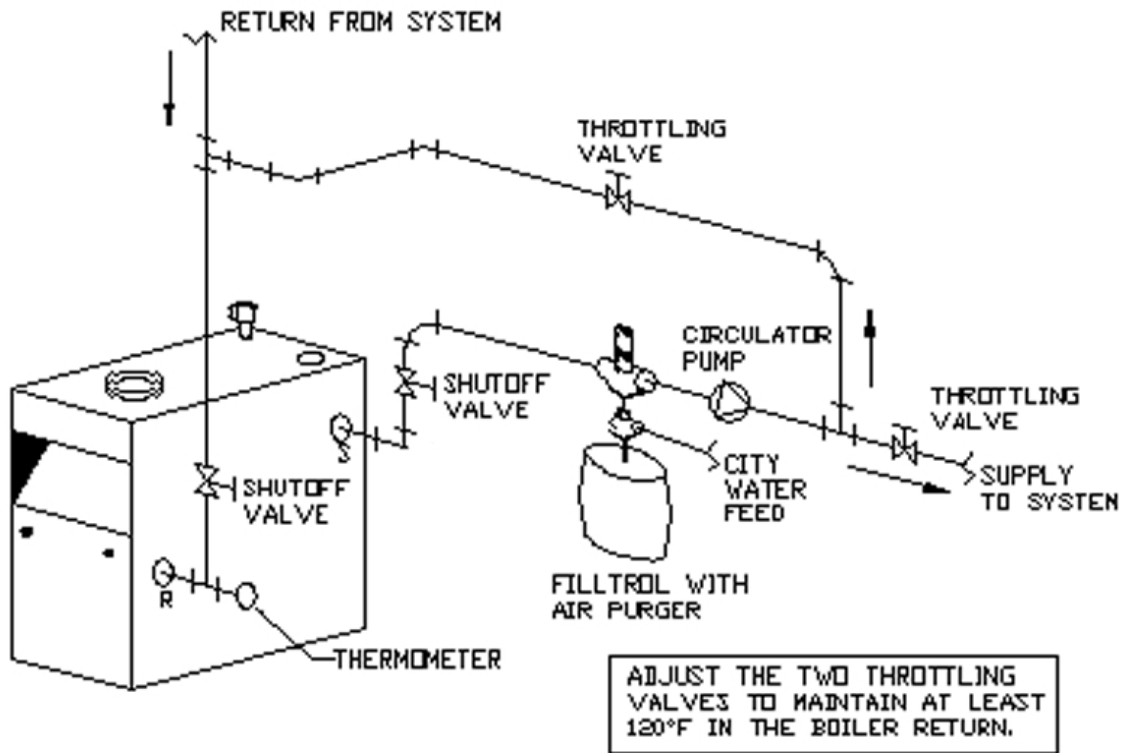
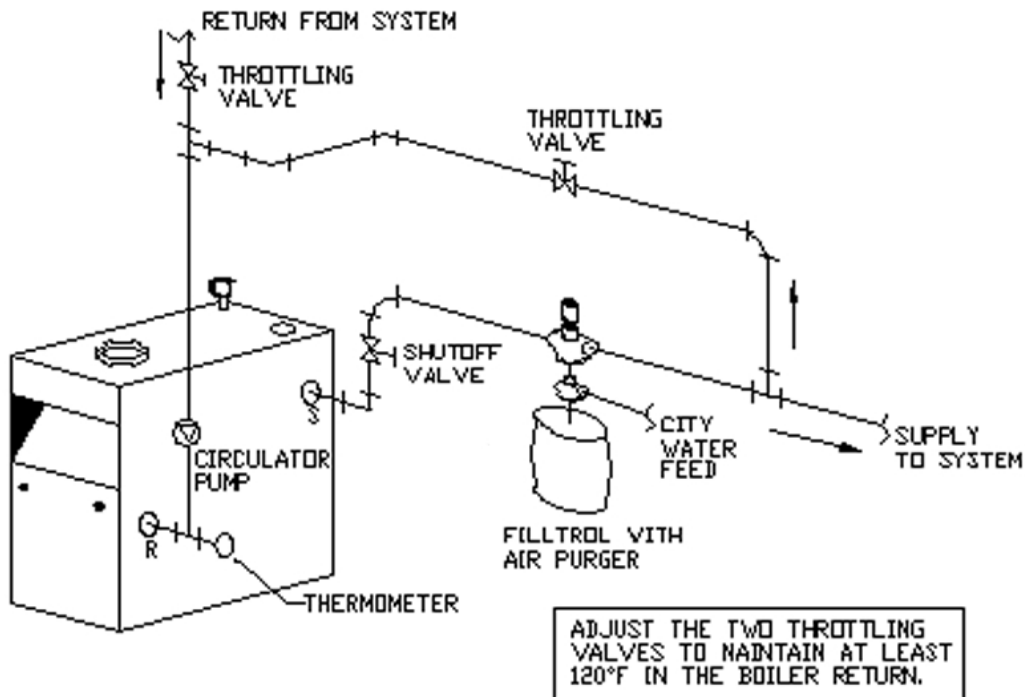

Figure 7 - BYPASS PIPING - CIRCULATOR ON RETURN



⚠ WARNING

Boiler and venting installations shall be performed by a qualified expert and in accordance with the appropriate manual. Installing or venting boiler or other gas appliance with improper methods or materials may result in serious injury or death due to fire or to asphyxiation from poisonous gases such as carbon monoxide which is odorless and invisible.

Boilers connecting to gas vents or chimneys, vent installations shall be in accordance with "Venting of Equipment", of the National Fuel Gas Code, ANSI Z223.1/NFPA 54 or "Venting Systems and Air Supply for Appliances," of the Natural Gas and Propane Installation Code, CAN/CSA B149.1, or applicable provisions of the local building codes.

Check Your Chimney

It must be clean, right size, properly constructed and in good condition.

Chimney Sizing

Chimney sizing, and vent installation must be in accordance with The National Fuel Gas Code, ANSI Z223.1/NFPA 54 or CAN/CSA B149.1, or applicable provisions of local building codes.

This is a high efficiency boiler with low stack temperature. Following recommendations are in addition to requirements of the National Fuel Gas Code.

1. Type B double wall vent pipe is recommended for vent connector. Single wall vent connectors should not be used unless following conditions are true:
 - a) Except for basement, boiler is not installed in unheated space.
 - b) Total horizontal portion of vent connector, not including elbows is less than 5 feet in length.
2. Outside chimneys (i.e. chimneys exposed to outdoors below roof line) should not be used unless they are:
 - a) enclosed in a chase, or
 - b) lined with type B vent pipe, or listed flexible vent liner, or other certified chimney lining system.
3. Where possible it is recommended to common vent boiler and water heater.
4. For multiple boiler installations, consult boiler manufacturer for venting recommendations.

Connecting The Vent Damper And Vent Connector

Refer to Figure 1, page 2 for size and location of vent (flue opening).

NOTICE

Damper blade on furnished vent damper has 1/2 square inch hole (approximately 3/4" diameter). Boilers equipped with intermittent ignition, hole should be plugged by using plug supplied with vent damper.

1. Position furnished vent damper on top of flue outlet collar. Fasten damper securely to flue outlet collar with sheet metal screws. Verify damper blade has clearance to operate inside of diverter. Do not modify either draft diverter or vent damper during installation.

As An Option

Damper may be installed in horizontal or vertical position, closer to flue outlet collar preferred. See Figures 8, 9 and 10 and enclosed vent damper instructions.

2. Install vent damper to service only single boiler for which it is intended. Damper position indicator shall be in visible location following installation. Locate damper so it is accessible for servicing. See Figure 9.
3. Damper must be in the open position when appliance main burners are operating.
4. Boiler is equipped with factory wired harness that plugs into vent damper.
5. Slope pipe up from boiler to chimney not less than 1/4" per foot.
6. Run pipe as directly as possible with as few elbows as possible.
7. Do not connect to fireplace flue.
8. End of vent pipe must be flush with inside face of chimney flue. Use a sealed-in thimble for chimney connection.

Fasten sections of vent pipe with sheet metal screws to make piping rigid. Support horizontal portions of vent system to prevent sagging. Use stovepipe wires every 5' to support pipe from above. Use double wall vent pipe if vent pipe must go through crawl space. Where vent pipe passes through combustible wall or partition, use ventilated metal thimble. Thimble should be 4 inches larger in diameter than vent pipe.

WARNING

Boiler and venting installations shall be performed by a qualified expert and in accordance with the appropriate manual. Installing or venting boiler or other gas appliance with improper methods or materials may result in serious injury or death due to fire or to asphyxiation from poisonous gases such as carbon monoxide which is odorless and invisible.

WARNING

Do not connect boiler to any portion of mechanical draft system operating under positive pressure.

Minimum Vent Pipe Clearance

Wood and other combustible materials must not be closer than 6" from any surface of single wall metal vent pipe. Listed Type B vent pipe or other listed venting systems shall be installed in accordance with their listing.

Removing Existing Boiler From Common Venting System

When an existing boiler is removed from common venting system, common venting system is likely to be too large for proper venting of appliances remaining connected to it.

At time of removal of existing boiler, following steps shall be followed with each appliance remaining connected to the common venting system placed in operation, while other appliances remaining connected to common venting system are not in operation.

1. Seal any unused openings in the common venting system.
2. Visually inspect the venting system for proper size and horizontal pitch and determine there is no blockage or restriction, leakage, corrosion and other deficiencies which could cause an unsafe condition.
3. Insofar as is practical, close all building doors and windows and all doors between the space in which the appliances remaining connected to the common venting system are located and other spaces of the building. Turn on clothes dryers and any appliance not connected to the common venting system. Turn on any exhaust fans, such as range hoods and bathroom exhausts, so they will operate at maximum speed. Do not operate a summer exhaust fan. Close fireplace dampers.
4. Place in operation the appliance being inspected. Follow the lighting instructions. Adjust thermostat so appliance will operate continuously.
5. Test for spillage at the draft hood relief opening after 5 minutes of main burner operation. Use the flame of a match or candle, or smoke from a cigarette, cigar or pipe.

6. After it has been determined that each appliance remaining connected to the common venting system properly vents when tested as outlined above, return doors, windows, exhaust fans, fireplace dampers and any other gas-burning appliance to their previous conditions of use.
7. Any improper operation of the common venting system should be corrected so the installation conforms with the National Fuel Gas Code, ANSI Z223.1/NFPA 54, and/or the Natural Gas and Propane Installation Code, CAN/CSA B149.1. When re-sizing any portion of the common venting system, the common venting system should be re-sized to approach the minimum size determined using the appropriate tables in Chapter 13 of the National Fuel Gas Code, ANSI Z223.1/NFPA 54, and/or the Natural Gas and Propane Installation Code, CAN/CSA B149.1.

Figure 8 - Vent Damper Installation

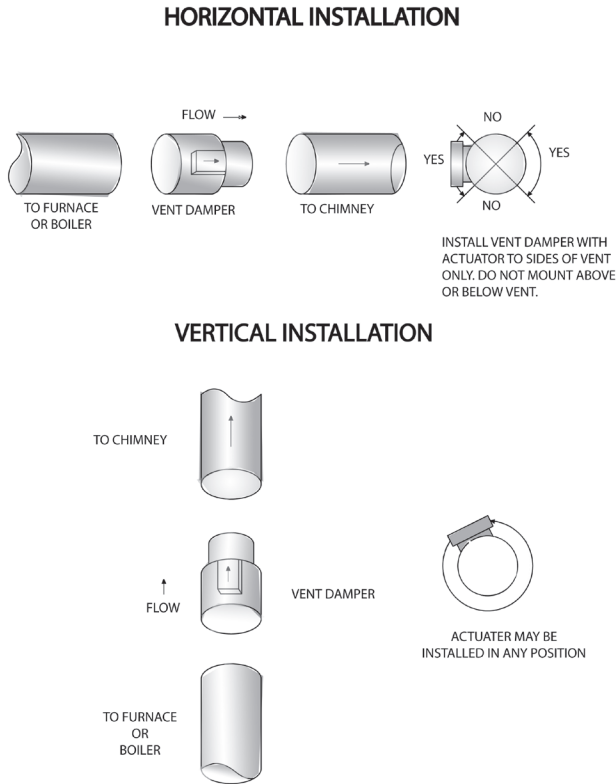
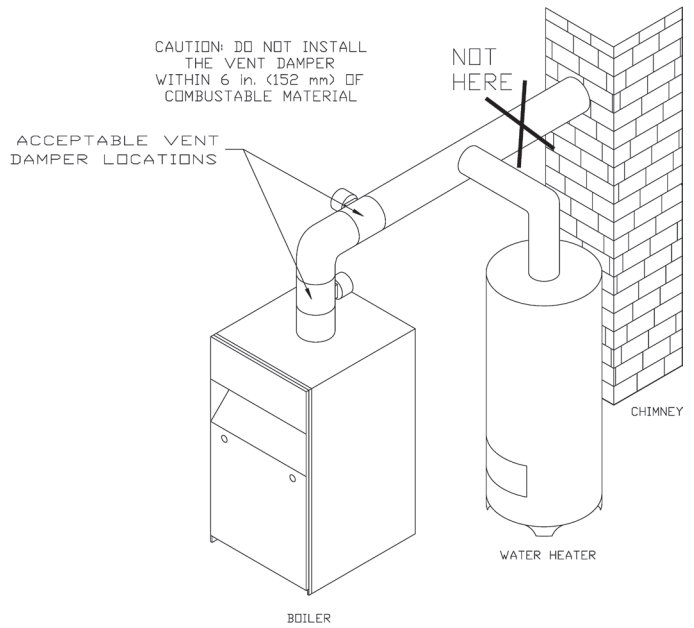

Figure 9 - Vent Damper Placement



Annually check vent damper and all flue product carrying areas of appliance, with particular attention given to deterioration from corrosion or other sources. If you see corrosion or other deterioration, contact your heating contractor for repairs. Check vent damper operation as follows:

- When boiler is off, check vent damper positions indicator points to closed position, Figure 10.
- Turn thermostat or controller up to call for heat and check vent damper indicator points to open position.
- Turn thermostat or controller down again and check damper position indicator returns to closed position.

Vent Damper Manual Operation

Vent damper may be placed in open position to permit burner operation by using "HOLD DAMPER OPEN" switch, located on damper controller. Thermostat will control burner firing as before, while damper will remain open. **DO NOT** turn damper open manually or motor damage will result. Set switch to "AUTOMATIC OPERATION" to close vent damper during burner off cycle.

For further information, and vent damper troubleshooting guide, refer to manual packaged with vent damper.

Inspect vent damper at least once a year by a qualified service technician.

Figure 10 - Vent Damper Position Indicator

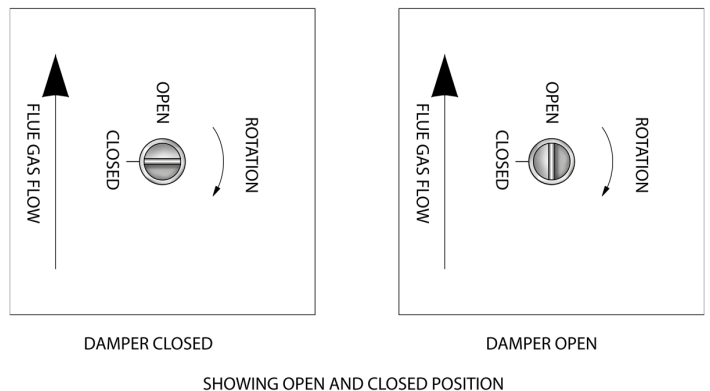

9 - GAS SUPPLY PIPING

⚠ CAUTION

WHAT TO DO IF YOU SMELL GAS

- Do not try to light any appliance.
- Do not touch any electrical switch; do not use any phone in your building.
- Immediately call your gas supplier from a neighbor's phone. Follow gas supplier's instructions.
- If you cannot reach your gas supplier, call the fire department.

CHECK GAS SUPPLY

Gas pipe to your boiler must be correct size for length of run and for total BTU per hour input of all gas utilization equipment connected to it. See Table 5 for proper size. Be sure your gas line complies with local codes and gas company requirements.

CONNECTING THE GAS PIPING See Figure 11.

Gas line enters boiler from right side.

- Use piping materials and joining methods acceptable to authority having jurisdiction. In absence of such requirements:
 - USA - National Fuel gas Code, ANSI Z223.1/NFPA 54
 - Canada - Natural Gas and Propane Installation Code, CAN/CSA B149.1
- Use pipe joint compound suitable for LP gas on male threads only.
- Use ground joint unions.
- Install sediment trap upstream of gas controls.
- Use two pipe wrenches when making connection to gas valve to keep it from turning.
- Install manual shut-off valve in vertical pipe about 5 feet above floor.
- Tighten all joints securely.
- Propane gas connections should only be made by licensed propane installer.
- Two-stage regulation should be used by propane installer.
- Propane gas piping should be checked out by propane installer.

CHECKING GAS PIPING

⚠ DANGER

Fire Hazard. Do not use matches, candles, open flames, or other methods providing ignition source. Failure to comply will result in death or serious injury.

Pressure test boiler and gas connection before placing boiler in operation.

- Pressure test over 1/2 psig (3.5 kPa). Disconnect boiler and its individual gas shutoff valve from gas supply system.
- Pressure test at 1/2 psig (3.5 kPa) or less. Isolate boiler from gas supply system by closing manual gas shutoff valve.
- Locate leakage using gas detector, noncorrosive detection fluid, or other leak detection method acceptable to authority having jurisdiction. Do not use matches, candles, open flames, or other methods providing ignition source.
- Correct leaks immediately and retest.

Table 5 - Gas Pipe Sizes

NATURAL GAS				
	Pipe Capacity - BTU Per Hour Input Includes Fittings			
Length of Pipe - FT	1/2"	3/4"	1"	1 1/4"
20	92,000	190,000	350,000	625,000
40	63,000	130,000	245,000	445,000
60	50,000	105,000	195,000	365,000
PROPANE GAS				
	Pipe Capacity - BTU Per Hour Input Includes Fittings			
Length of Pipe - FT	Copper Tubing *		Iron Pipe	
	5/8"	3/4"	1/2"	3/4"
20	131,000	216,000	189,000	393,000
40	90,000	145,000	129,000	267,000
60	72,000	121,000	103,000	217,000

* **Outside diameter**
Measure length of pipe or tubing from gas meter or propane second stage regulator.

Figure 11 - Gas Piping

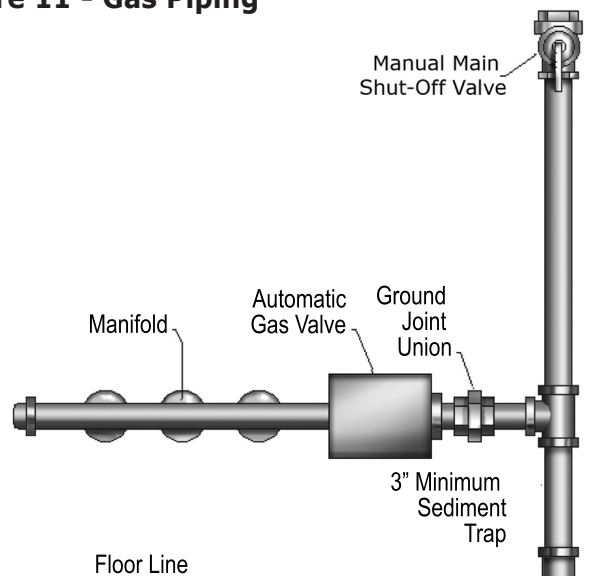

WARNING

Electrical shock hazard. Turn OFF electrical power supply at service panel before making electrical connections. Failure to do so could result in death or serious injury.

NOTICE

Label all wires prior to disconnection when servicing controls. Wiring errors can cause improper and dangerous operation. Verify proper operation after servicing.

VENT DAMPER WIRING

Boiler is equipped with factory wired harness with 4 pin molex plug, that plugs into 4 pin molex receptacle inside vent damper operator.

Vent damper must be connected for boiler to operate.

If any of the original wire as supplied with this appliance must be replaced,

It must be replaced with type 105°C thermoplastic wire or its equivalent.

Electrically bond boiler to ground in accordance with requirements of authority having jurisdiction. Refer to:

- USA- National Electrical Code, ANSI/NFPA 70.
- Canada - Canadian Electrical Code, Part I, CSA C22.1: Safety Standard for Electrical Installations.

ELECTRIC POWER SUPPLY

Run separate 120 volt circuit from separate over current protective device in electrical service entrance panel. This should be a 15 ampere circuit. Locate shut-off switch at boiler. It must be turned off during any maintenance. Connect 120 volt power supply to control leads L1 (HOT) and L2.

LWCO kit 550002998 includes wiring instructions and diagrams. If using another LWCO, refer to specific manufacturer instructions supplied by appropriate manufacturer.

Run a 14 gauge or heavier copper wire from boiler to grounded connection in service panel or properly driven and electrically grounded ground rod.

THERMOSTAT INSTALLATION

1. Thermostat should be installed on an inside wall about four feet above the floor.
2. NEVER install thermostat on outside wall.
3. Do not install a thermostat where it will be affected by drafts, hot or cold pipes, sunlight, lighting fixtures, televisions, a fireplace, or a chimney.
4. Check thermostat operation by raising and lowering thermostat setting as required to start and stop the burners.
5. Instructions for the final adjustment of the thermostat are packaged with the thermostat (adjusting heating anticipator, calibration, etc.)

Set heat anticipator at .2 amps. 24 volt thermostat connects to aquastat terminals T and TV.

Figure 12 - Integrated High Limit Electronic Ignition Control

⚠ WARNING

Modification, substitution or elimination of factory equipped, supplied or specified components may result in personal injury or loss of life.

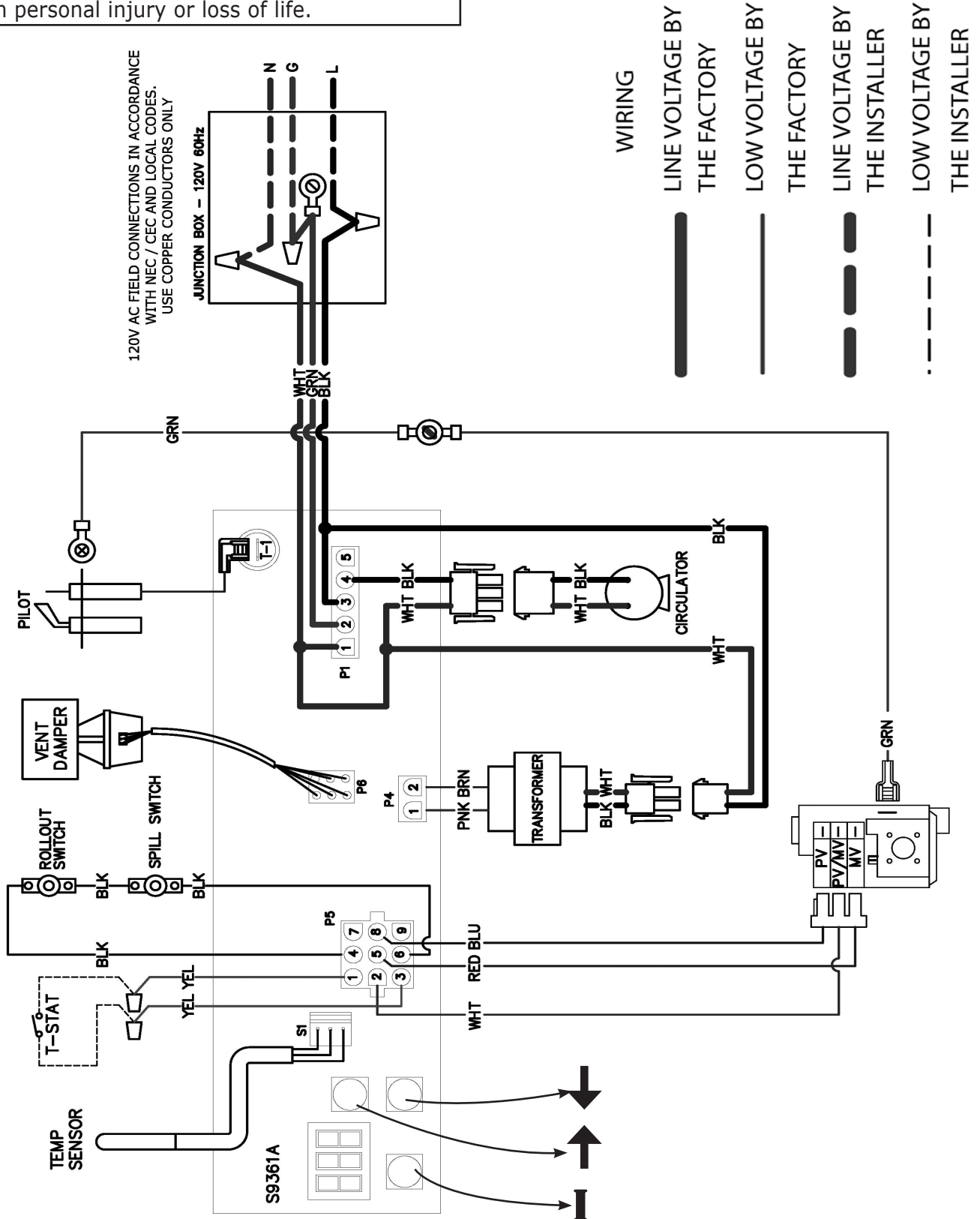

120V AC FIELD CONNECTIONS IN ACCORDANCE WITH NEC / CEC AND LOCAL CODES. USE COPPER CONDUCTORS ONLY

WIRING

- LINE VOLTAGE BY THE FACTORY
- LOW VOLTAGE BY THE FACTORY
- - - LINE VOLTAGE BY THE INSTALLER
- - - LOW VOLTAGE BY THE INSTALLER

Figure 13 - Integrated High Limit Electronic Ignition Control

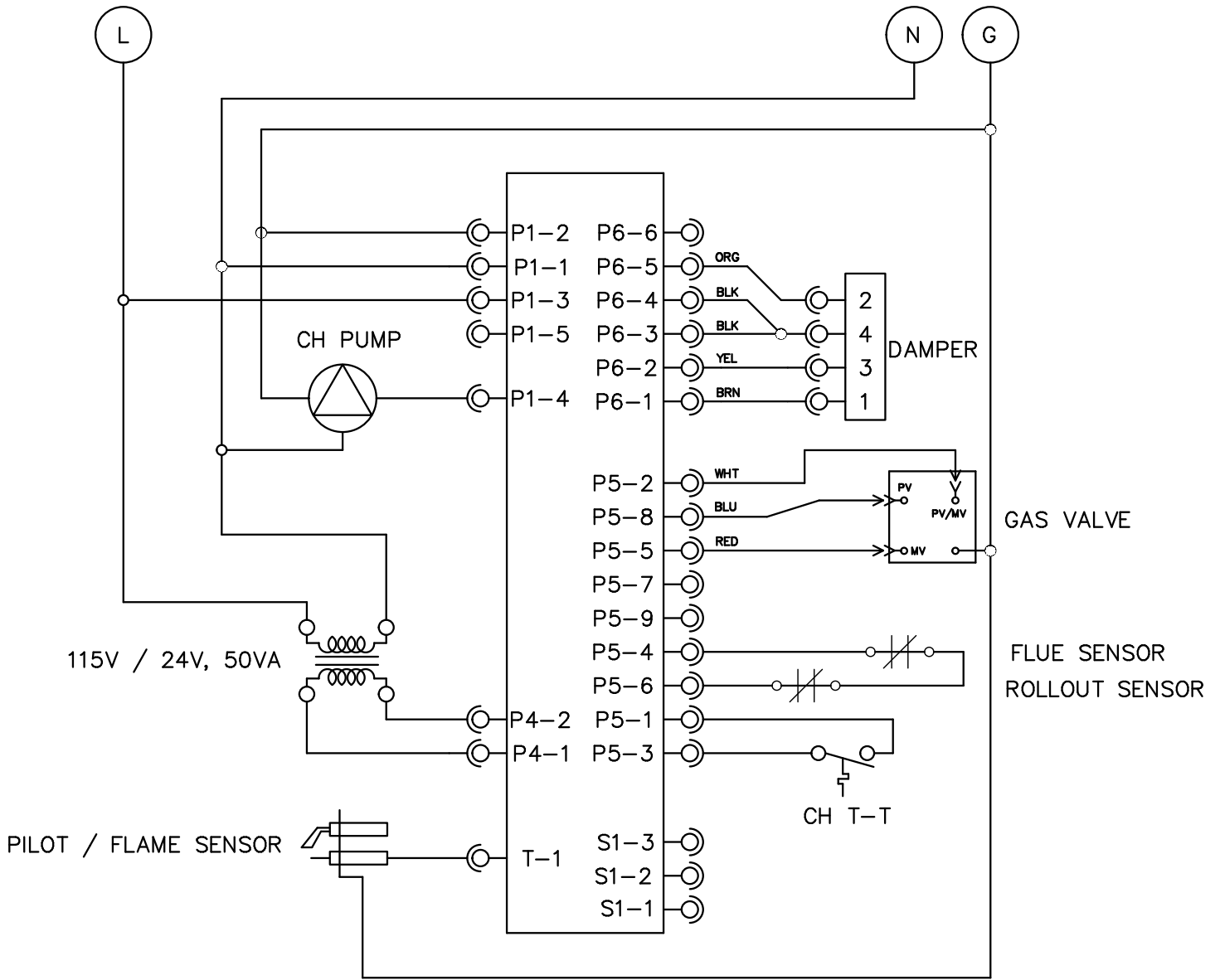

LADDER DIAGRAM: HOT WATER - ATMOSPHERIC DRAFT BOILER

FILLING SYSTEM WITH WATER

- Close air vents on all radiation units. Open valves to these units.
- Verify boiler and expansion tank drain valves are closed.
- Air bleed screw on tank drain fitting should be closed.
- Open valve in line from boiler to expansion tank. Open water inlet to your boiler and leave it open. Start with lowest radiation unit. Open air vent on this unit. When all air has escaped and water starts to flow from vent, close it.
- Go to next radiation unit, and repeat this process. Repeat until you have covered every radiation units in the system (ending up at highest unit in system).
- If your units have automatic vents, manual venting is unnecessary but it will speed up the proper filling of your system.
- If your system is closed expansion tank system, you may leave it open to refill system automatically as needed.
- Check temperature pressure gauge. Not position of hand indicating pressure. This should be between 10 and 15 psi. Any lowering of this movable hand below 10 psi. Will indicate loss of water due to leakage. Automatic fill valve should compensate for this. Instructions are packaged with the valve.

NOTICE

Never run water in a hot empty boiler.

⚠ WARNING

If you do not follow these instructions exactly, a fire or explosion may result causing property damage, personal injury or loss of life.

- This appliance is equipped with an ignition device which automatically lights burner. **Do NOT try to light this burner by hand.**
- Before operating smell all around appliance area for gas. Be sure to smell next to floor because some gas is heavier than air and will settle to the floor.
- **Use only your hand to turn the gas shutoff valve.** Never use tools. If valve will not turn by hand, do not try to repair it, call a qualified service technician. Force or attempted repair may result in fire or explosion.
- **Do not use this appliance if any part has been under water.** Immediately call a qualified service technician to inspect appliance and to replace any part of control system and any gas control which has been under water.

LIGHTING PROCEDURE FOR BOILER WITH INTERMITTENT PILOT SYSTEM

For Your Safety, Read Before Operating!!

- A. This appliance is equipped with an ignition device which automatically lights the pilot. Do not try to light appliance by hand.

⚠ CAUTION

WHAT TO DO IF YOU SMELL GAS

- Do not try to light any appliance.
- Do not touch any electrical switches; do not use any phone in your building.
- Immediately call your gas supplier from a neighbor's phone. Follow the gas supplier's instructions.
- If you cannot reach your gas supplier, call the fire department.

1. STOP! Read the safety information above.
2. Set the thermostat to lowest setting.
3. Turn off all electric power to the appliance.
4. This appliance is equipped with an ignition device which automatically lights the pilot. Do **not** try to light the pilot by hand.

5. Remove lower front panel.
6. Rotate the gas control knob clockwise to "OFF".

Figure 14 - Automatic Gas Valve

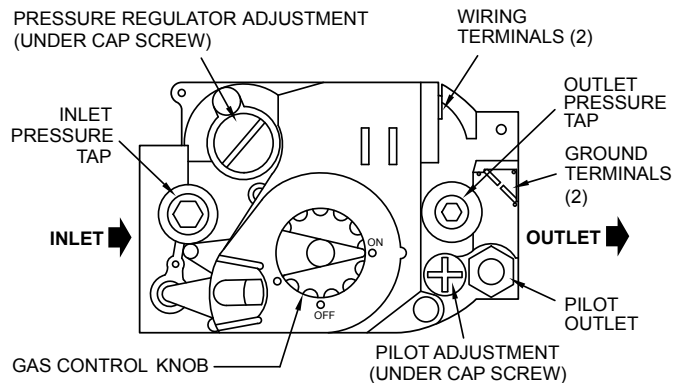

7. Wait five (5) minutes to clear out any gas. Then smell for gas, including near the floor. If you smell gas, STOP! Immediately call your gas supplier from a neighbor's phone. Follow the gas supplier's instructions. If you don't smell gas, go to next step.
8. Rotate gas control knob counterclockwise to "ON".
9. Replace lower front panel.
10. Turn on all electric power to the appliance.
11. Set thermostat to desired setting.
12. If the appliance will not operate, follow the instructions "To Turn Off Gas To Appliance" and call your service technician or gas supplier.

TO TURN OFF GAS TO APPLIANCE

1. Set the thermostat to lowest setting.
2. Turn off all electric power to the appliance if service is to be performed.
3. Push in gas control knob slightly and turn clockwise to "OFF" Do not force.

AUTOMATIC GAS VALVE

Automatic Gas Valve opens or closes according to heat requirements of thermostat and temperature limit control. It closes if pilot goes out. Each individual control must be operating correctly before any gas can pass to burners. Any one control can hold gas supply from burner regardless of demand of any other control.

SAFETY PILOT

Safety Pilot prevents flow of gas to burner if pilot goes out, or will not ignite.

GAS VALVE SAFETY SHUTDOWN TEST

Ignition system safety shutoff device must be tested after placing boiler in operation.

RELIGHT

Electric and gas shall be off for 5 minutes before relighting.

THERMOSTAT

Keep it set at desired room temperature. If windows are to be opened or heat is not needed, move thermostat pointer to lower setting.

NOTICE

In event of failure of any component, system will not operate or will go into safety lockout. System is completely self-checking. On every call for heat, each component must be functioning properly to permit operation. Safety lockout system has to be reset by turning thermostat to lowest setting for one minute, then back to normal setting.

ADJUST PILOT BURNER

Pilot flame should surround 3/8" to 1/2" of the pilot sensor. See Figure 15. If flame needs adjusting, do it as follows:

1. Remove screw cover over pilot adjusting screw.
2. Insert small screwdriver and adjust flame as needed. Turn screw counterclockwise to increase flame, clockwise to decrease.
3. Replace screw cover over pilot adjusting screw.

Figure 15 - Pilot Flame

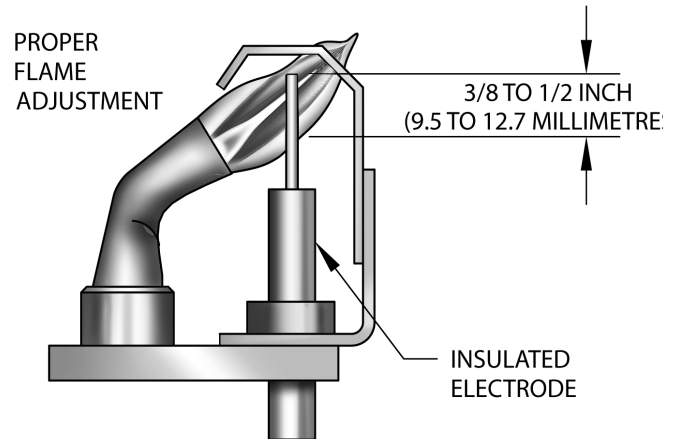

MAIN BURNER(S)

- Main burners do not require primary air adjustment and are not equipped with primary air shutters.
- Main burner flames form sharp blue inner cones in softer blue outer mantel, with no yellow.
- Puffs of air from blowing on flame or stamping on floor will cause flames to turn orange momentarily. This is not unusual. Remain still when observing main burner flames.
- If flame appearance is not correct, check main burner orifices, burner throat and flame ports for dust and lint obstruction. It may be necessary to remove rollout shield to observe main burner flames. Replace rollout shield after observation. Refer to Figure 16.

Figure 16 - Burner

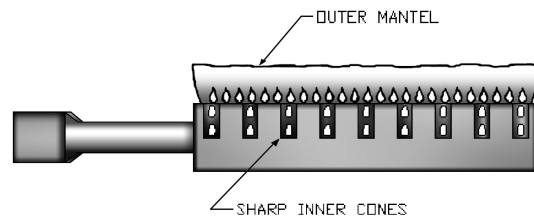

ADJUST LIMIT CONTROLS

Instructions for each control are included with controls. Settings can be changed. Refer to Appendix A page 26 for information.

CHECK THERMOSTAT OPERATION

- A. When set above temperature indicated on thermostat, boiler should ignite.
- B. Verify thermostat turns boiler off when room temperature reaches selected setting and starts boiler operating when room temperature falls a few degrees.
- C. After setting limit control to limit setting, check to see if it shuts off gas supply to burners. Turn your thermostat up to call for heat and let boiler run until temperature of water reaches limit setting. Gas valve should shut off and circulator running until thermostat is satisfied, or water cools enough to restart burners through limit control.
- D. Set thermostat for desired temperature. Conditions in your home and location of thermostat will govern this setting.

15 - SERVICE HINTS

CAUTION

WHAT TO DO IF YOU SMELL GAS

- Do not try to light any appliance.
- Do not touch any electrical switch; do not use any phone in your building.
- Immediately call your gas supplier from a neighbor's phone. Follow the gas supplier's instructions.
- If you cannot reach your gas supplier, call the fire department.

IF YOUR SYSTEM IS NOT HEATING OR NOT GIVING ENOUGH HEAT . . .

You may avoid inconvenience and service calls by checking these points before you call for service.

Possible Cause

What to do

Thermostat is not set correctly

Reset thermostat above room temperature

Burner is not operating properly

Check flame. If it is yellow, burner is not getting enough air. Or, if flame is blue and noisy and seems to lift off burner, burner is getting too much air. Contact your service technician.

No electric power to boiler

Check over current protection. Verify electric power supply circuit is "ON".

Controls out of adjustment

Reset according to instructions.

Radiators not heating

Open radiator vents to expel air. Check flow control valve (if used). It may be in closed position.

Circulating pump not running

Check over current protection. Check relay operation.

Poor electrical contact

Check all control terminals and wire joints.

Rollout switch blown

Have your service agent check heat exchanger for blockage. Replace rollout switch with exact replacement.

Blocked vent blown

Have your service agent check venting system and chimney for blockage, or down draft condition. Reset blocked vent.

Vent damper not operating

Consult troubleshooting guide in Effikal manual, packaged with vent damper.

IF BURNER IS NOISY . . .

Possible Cause

What to do

Gas input amount is incorrect

Contact your service agent.

RELIEF VALVE LEAKING . . .

Possible Cause

What to do

Dirt on seat

Open valve manually. Allow water to run and clear valve seat.

Water logged expansion tank

Drain tank, see instructions.

HAVE YOUR SERVICE AGENT CHECK ANY PROBLEM YOU ARE UNABLE TO CORRECT.

BURNERS

Beginning of heating season visually check pilot and main burner flames. See Page 16 & 17.

SAFETY RELIEF VALVE

Refer to page 7 for important information. To test safety relief valve refer to valve manufacturer's instructions packaged with relief valve. Call Technical Support if manufacturer's instruction are not located.

EXPANSION TANK

Tank may become waterlogged, or may receive excess of air. Frequent automatic opening of safety relief valve indicates water logging. High boiler temperature accompanied by unusually low radiation unit temperature (and "knocking") indicates excess air in tank.

To correct:

1. Close valve between boiler and tank. Drain tank until empty.
2. Check all tank plugs and fittings. Tighten as necessary.
3. Open valve between boiler and tank. Water will rise to normal height in tank if you have automatic fill valve (otherwise, manually refill system).

BOILER FLUE PASSAGES

Recommend following checked annually by qualified service agent.

- flue passages
- burner adjustment
- operation of controls

Before start of each season (or whenever system has been shut down for some time) recheck whole system for leaks and recheck boiler and vent pipe for leaks. Replace or patch any boiler seals that are faulty.

VENT PIPE

Venting and piping should be checked at least once a season. If vent piping shows any sign of leaking, replace immediately.

WATER SYSTEM

If system is to remain out of service during freezing weather, always **drain it** completely (water left in to freeze will crack pipes and/or boiler).

CLEANING YOUR BOILER AND BURNERS

Flue passages between sections should be examined yearly and cleaned if necessary.

To clean:

- Remove burners, pilot, and vent pipe.
- Remove top and front jacket panels.
- Remove two screws attaching intermediate front panel to left and right side jacket panels.
- Remove draft diverter and intermediate front panel together.
- Carefully remove cerafelt gasket strips.
- Clean passageways between sections with flexible handle wire brush. Remove dirt from bottom of boiler and from between sections by vacuuming.
- Verify all flame ports in burners are open and clear. Shake out or blow out all loose dirt in burners.
- Reseal seams between adjacent sections as necessary with 400° F RTV silicone sealant.
- Reassemble all parts.
- Verify tightness of pilot connections and condition of burner flames after reassembly. See Figures 15 and 16, pages 20.
- Verify vent pipe connections to chimney are secure and no obstructions are present.

HOUSEKEEPING

- Keep boiler area clear and free from combustible materials, gasoline and other flammable vapors and liquids.
- Keep boiler area clear of debris and other materials obstructing flow of combustion and ventilation air.

A.1 Installation Environment Considerations

⚠ WARNING

If you do not follow these instructions exactly, a fire or explosion may result causing property damage, personal injury or loss of life.

- **Do not use this appliance if any part has been under water.** Immediately call a qualified service technician to inspect appliance and to replace any part of control system and any gas control which has been under water.
- Do not allow water to drip on controls. Prevent condensation by allowing air circulation around module and gas control.
- Do not use corrosive chemicals around or on module or gas control.

- Controls can be damaged by excessively high temperatures. Verify adequate air circulation around control is maintained when installing boiler.

A.2 Electrical Connections

Connect Module Connectors Figure 12, Page 16

- L, N, & G leads inside J-box using wire nuts. Secure J- box cover.
- Circulator harness to circulator. Harness comes plugged into module with Molex[®] plug.
- Thermostat connection to yellow wires marked TT using wire nuts.
- Ensure remaining Molex[®] plug connectors have not worked loose during transit.
- Check sensing bulb is fully inserted in well and is not loose.
- Refer to enclosed addendum for wiring instructions when using indirect hot water heater.
- Verify vent damper connection is made. See page 13.

A.3 Adjusting Settings

To discourage unauthorized changing of settings, procedure to enter adjustment mode is required.

To enter adjustment mode, press UP, DOWN, and I buttons simultaneously for three seconds. Press and release I button until parameter requiring adjustment is displayed.

See Figure 12, page 16.

- "SP_" Setpoint (180 °F default setting; adjustable between 130 and 220 °F) Note: on some models this is "HL" High Limit.
- "Df_" Setpoint Differential (15 °F default setting; adjustable between 10 and 30 °F)
- "°F_" Degrees Fahrenheit

Press UP or DOWN button until parameter has reached desired value. After 60 seconds without any button inputs, control automatically returns to READ mode.

A.4 Display

In RUN mode, status items and parameters are viewable.

Example, to display setpoint, control flashes "sp" (setpoint) followed by temperature (i.e., 135), followed by °F or °C.

To read settings, press and release I key to find parameter of interest.

Example, press and release I until setpoint (sp) is displayed, followed by three-digit number, i.e., 190, followed by °F or °C. Press I button again will display (S1T) Sensor 1 Temperature followed by three-digit number and corresponding degree designator.

See Display Readout.

Figure 17 - Display Readout

TEXT	DESCRIPTION	DISPLAY SHOWS
STA	STATUS (SEE STATUS NUMBERS)	StA
BT	BOILER TEMPERATURE	bT
SP	OPERATING SETPOINT	SP
HL	HIGH LIMIT SETPOINT	HL
HDF	DIFFERENTIAL SETPOINT	HdF
FLA	FLAME CURRENT	FLA
RUN	RUN TIME HOURS	run
CYC	BOILER CYCLES	CYC
ERR	ERROR (SEE ERROR NUMBERS)	Err

M33683

APPENDIX A - CONTROL MODULE

A.5 Operation

Module continuously monitors boiler water temperature and fires or shuts off burner based on this temperature data.

1. When "Call for Heat" occurs, control enables circulator and monitors boiler water temperature to determine whether thermostat can be satisfied without firing burners.
2. Control determines burner operation is required, module proceeds to start burner (see state codes list) and heats water in boiler until setpoint temperature is achieved or thermostat is satisfied. .
3. Burner is de-activated, ignition module completes heating cycle, returns to idle and waits for temperature to drop again.
4. Circulator is turned on throughout "Call for Heat."

Table 6 - Vent Damper Models Operation State Codes

1. State code sequence through a normal heat cycle			
Order	State Code Number	Definition	Explanation
a	1	Idle	There is no call for heat and or:
b	1	Circulator	Thermostat has call for heat. Control has activated system circulator pump and is waiting to see if there is enough heat to satisfy the thermostat without firing the burners. This may last as long as 2 minutes, but will typically be much less.
c	17	Diagnostics	Pilot valve diagnostics/current leakage detection. Typically a few seconds.
d	18	Wait for damper to open	Vent damper should be closed while boiler is off to conserve energy. Now, the vent damper must open before burner can safely be lit. The vent damper must confirm it is open (a switch closes to do this). The control is waiting for this to occur. This may last up to one minute. If the vent damper switch has not closed after one minute, ERR 55 will be displayed.
e	17	Diagnostics	Another diagnostic check. The control will also check the safety switches (rollout and vent) are closed. This will be so quick the control may move on before the STA code is flashed. Should the safety switches be detected open, the control will show STA15 for as long as the switches are open.
f	6	Spark	Spark for ignition. There should be an audible sparking (buzzing) noise. This will last until the control detects a pilot flame, but not more than 30 seconds (90 for S9361A2095). (If no flame is detected after the trial period, sparking will cease, and a 5 minute delay will occur before the control tries again. STA10 will be displayed during this period).
g	7	Flame stabilization	The pilot flame must be strong enough(1 μ A) for the control to release the main burners. This will last up to 10 seconds. (If the flame is still not strong enough after 10 seconds, the control will shut off the pilot, wait 5 minutes, then try again. STA10 will be displayed during the 5 minute period).
h	8	Running	Main burners are providing heat. This will continue as long as the thermostat requires. During this period, the control will monitor the pilot signal, boiler temperature, damper, and limit switches to assure safe operation.
g	1	Post operation	The damper will close again to conserve heat, and the circulator pumps will continue for a short time to deliver stored heat to the house before it has a chance to escape during the upcoming off period.

APPENDIX A - CONTROL MODULE

Table 6 conti. - Vent Damper Models Operation State Codes

Order	State Code Number	Definition	Explanation
2. Other possible state codes			
h	4	Pre-purge	System is purging before ignition trial; includes Pilot Valve circuit diagnostics. On vent damper models, this is so quick it will typically be over before the display can flash this code, and therefore will rarely be visible.
i	9	Post-purge	System is purging after heat cycle. On vent damper models, this is so quick it will typically be over before the display can flash this code, and therefore will rarely be visible.
j	10	Retry Recycle Delay	5 minute delay after pilot signal is lost. Either: 1. Control failed to detect flame after spark period. Check pilot for contamination, check ignition wire; check electrical ground; Check pilot flame. 2. Control lost pilot flame signal AFTER main burners were lit. Check for adequate draft and combustion air. Check gas line for adequate pressure.
k	13	Soft lock out	Soft lock out duration is one hour, may override with manual reset. Appropriate error code will flash alternately.
l	14	Hard lock out	Requires manual reset. Unacceptable high water temperature (err 65) and onboard electronics failure (er 18) are the only two (2) hard lockouts on this model.
m	15	Wait for limit to close	One of the safety limits - rollout, vent spill, or low water cutoff (if one is field installed on the 24V safety circuit) has been activated. Control will resume normal operation once limit is reset. Underlying cause why the limit switch opened MUST be investigated.
n	16	Flame out of sequence	Flame signal sensed before trial ignition. Appropriate alarm is sent. OR Flame signal sensed out of sequence during post purge OR Flame signal present when not expected. Appropriate alarm is sent.
o	17	Diagnostics	Onboard self check performed at various points during the operation sequence.
p	19	Wait for damper switch to close	Damper is closed and control waits for damper switch to close. Checked at beginning of heat cycle before opening damper. If damper does not open in 60 seconds, control goes to State 20. Control may also be in state 15 if one of the safety limits is open.
q	20	Wait for damper to open (Failed close)	Damper has not opened (end switch not closed) at beginning of heat cycle. Alarm message is sent, control is NOT in lockout. Control will resume normal operation once the damper opens.
r	21	Wait for damper to close (Failed open)	Damper has not closed despite actuator de-energized. Alarm message sent, control is NOT in lockout.

A.6 Boiler High Limit Temperature Controller

- When water temperature reaches setpoint, controller ends heating cycle.
- When water temperature drops below setpoint minus differential, controller restarts heat cycle to re-heat boiler water.
- If water temperature exceeds maximum allowed temperature (220°F or 104°C), controller enters manual reset lockout state.
- For models having reset capability, press any onboard button or cycle power to reset.

A.7 Troubleshooting

- Following service procedures are provided as general guide.
- On lockout and retry models, meter readings between gas control and ignition module must be taken within trial for ignition period. Once ignition module shuts off, lockout models must be reset through key buttons and display. On retry models, wait for retry or reset at thermostat.
- Check for correct installation and wiring before replacing any component.
- Control module cannot be repaired. If it malfunctions, it must be replaced.
- Use only qualified service agent to service ignition systems.

Figure 18 - Basic Control Algorithm Example

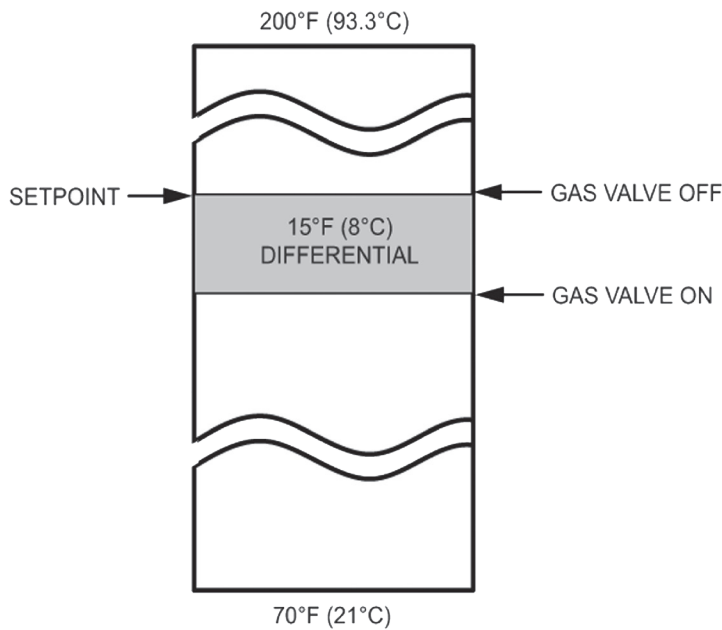

1. Perform checkout as first step in troubleshooting. Check troubleshooting guide to pinpoint cause of problem. See Table 7 , page 29.
2. If troubleshooting indicates ignition problem, see Ignition System Checks to isolate and correct the problem.
3. Perform checkout procedure following troubleshooting guide again to verify system is operating normally.

A.8 Troubleshooting Error Codes

Integrated boiler control uses advanced diagnostic capability to assist in troubleshooting error conditions. Table 7 page 29 shows codes that could arise on integrated display during fault. Suggestions are provided in Table 7 page 29 for servicing these potential errors.

APPENDIX A - CONTROL MODULE

Table 7 - Troubleshooting Error Codes

Error Code Number	Definition	Error Display clearing (once error condition has disappeared)					Explanation	Things to look for
		Clears itself when root problem is solved	Cycle Power OFF	Push any key	Up/down key when status is displayed			
4	Flame current lower than threshold	*	*			Control requires a strong enough signal to verify flame is present. Signal too low.	<ol style="list-style-type: none"> 1. Check pilot flame sense is clean. 2. Check for proper ground 3. Check wiring 4. Check for correct pilot orifice 5. Check there are no gas leaks in pilot tubing 	
6	Flame sensed out of normal sequence		*			Control circuit is sensing flame rectification when there should be none.	<ol style="list-style-type: none"> 1. Check gas valve 2. Check all electrical connections are tight 	
18	Electronic failure			*	*	Control believes it is defective	<ol style="list-style-type: none"> 1. Try reset by cycling power or push any key 2. Check wiring to pilot and main valve 3. Control requires replacement 	
23	Flame sensed during Pre-purge		*			Primarily for induced draft models although present in vent damper software. Pilot is being sensed to soon in ignition sequence.	<ol style="list-style-type: none"> 1. Check gas valve 2. Check all electrical connections are tight 	
24	Flame sensed during Post-purge		*		*	Primarily for induced draft models although present in vent damper software. Pilot is being sensed to late in shutdown sequence.	<ol style="list-style-type: none"> 1. Check gas valve 2. Check all electrical connections are tight 	
32	Temperature sensor failure	*	*		*	Temperature sensor is not providing expected reading.	<ol style="list-style-type: none"> 1. Check sensor is plugged into control board 2. Check sensor wiring is not damaged 3. Scroll display reading to "bt" and hold sensor bulb securely in you hand. It should read a temperature close to body temperature. If not, replace sensor. 	
55	Damper end switch failed to close	*	*			Vent damper must confirm it is open (switch closes to do this). Control did not receive this signal after waiting one minute, and is still waiting.	<ol style="list-style-type: none"> 1. Check vent damper harness is securely connected to both vent damper and control board. 2. Check vent damper harness is not damaged. 3. Check vent damper mechanism is operating freely. 4. See Appendix B 	
56	Damper end switch failed to open	*	*			Vent damper must confirm it is closed (switch opens to do this) after a heat call. The control did not receive this signal after waiting one minute, and is still waiting.	<ol style="list-style-type: none"> 1. Check vent damper harness is connected to both vent damper and control board. 2. Check vent damper harness is not damaged. 3. Check vent damper mechanism is operating freely. 4. See Appendix B 	
57	Flame rod shorted to burner ground	*	*			Control did not detect a voltage difference between flame sense wire and ground.	<ol style="list-style-type: none"> 1. Check flame sense wire on pilot assembly is not frayed or damaged. If so, replace pilot assembly. <p><i>Note! These are high temperature wires. DO NOT attempt field repair.</i></p> <ol style="list-style-type: none"> 2. Check there is no moisture collecting on the control board. 	
58	AC line frequency error	*	*			AC frequency is incorrect or noisy.	<ol style="list-style-type: none"> 1. Some electric or electronic devices may generate electromagnetic interference. Verify none is present. 2. Check thermostat connection. 	

APPENDIX A - CONTROL MODULE

Table 7 - Troubleshooting Error Codes - conti.

Error Code Number	Definition	Error Display clearing (once error condition has disappeared)					Explanation	Things to look for
		Clears itself when root problem is solved	Cycle Power OFF	Push any key	Up/down key when status is displayed			
59	Line voltage error	*	*			Line voltage (or, possibly thermostat) is either too high or too low.	Source problem is likely in the electrical external to the boiler. Control will clear itself and resume normal operation once the situation is resolved. Check BOTH line power and thermostat wiring.	
60	Thermostat input higher than threshold	*	*			Some types of thermostat may not be compatible with control circuitry.	Verify boiler works properly by jumping yellow thermostat wires. If so, replace thermostat (or thermostat wires).	
61	Line Voltage unstable	*	*			Unstable line voltage - possibly to many heavy loads switching on and off.	<ol style="list-style-type: none"> 1. Check current draw on this branch circuit from house breaker box might have very heavy loads switching on or off. 2. Check power coming into the house. Source problem is likely in the electrical external to the boiler. Control will clear itself and resume normal operation once the situation is resolved. 	
62	Soft Lockout-Max retries exceeded		*	*		Control sensed consecutive instances of no flame signal while trying to light pilot. Note: not present on S9261A2095.	<ol style="list-style-type: none"> 1. Check control ground connection. 2. Check pilot ignition wire for good condition and connection. 3. Clean pilot tip. 4. Check pilot tube, assure no gas leaks. 5. Check correct pilot orifice is being used. 6. Check gas line pressure. 	
63	Soft Lockout - Max recycles exceeded		*	*		Control sensed consecutive instances of loss of pilot flame signal AFTER main burners are lit. Note: not present on S9261A2095.	<ol style="list-style-type: none"> 1. Check gas valve & gas supply. 2. Check all electrical connections are tight. 3. Check pilot rod is clean. 4. Check for adequate draft. 5. Check for adequate combustion air. 	
64	Soft Lockout - Internal failure		*	*		Control is sensing something wrong with electrical circuitry.	<ol style="list-style-type: none"> 1. Check all wiring is correct. Refer to wiring diagram. 2. Check there is a good ground to pilot bracket. 	
65	Hard Lockout - Temperature above limit		*	*		Control sensed water temperature too high for safe boiler operation	<ol style="list-style-type: none"> 1. Check water is circulating properly through boiler. 2. Check there is not air in the system. 3. If pressure relief valve is opened, there is definitely a problem with water circulation! 4. If any of the above 3 are true, root problem is in the hot water circulation. 5. Scroll display reading to "bt" , and hold sensor bulb securely in your hand. It should read a temperature close to body temperature. If not, replace sensor. 	

Note: In event of multiple errors, the highest error number is displayed first.

Note: Error codes 18 and 65 - Hard Lockout will not expire. Requires operator reset. No volatile memory (error will not be remembered if power is off).

Error codes 6, 23, 62,63 and 64 - Soft Lockout of 1 hour duration if not reset. Control will then resume normal operation. If source error is still present a second soft lockout is possible.

All other codes - No lockout. Control will resume normal operation immediately when source error is resolved.

A.9 Intermittent Pilot

Ignition System Checks

STEP 1: Check ignition cable.

- Verify ignition cable does not touch metal surfaces.
- Verify only factory supplied Ignition cable (or approved replacement) is used.
- Verify connections to ignition module and igniter or igniter-sensor are clean and tight.
- Verify ignition cable provides good electrical continuity.

STEP 2:

Verify ignition system grounding. Nuisance shutdowns are often caused poor or erratic grounding.

Common ground is required for module and pilot burner/igniter sensor.

- Check for good metal-to-metal contact between pilot burner bracket and the main burner.
- Check ground lead from GND (BURNER) terminal on module to pilot burner. Verify connections are clean and tight. If wire is damaged or deteriorated, replace with No. 14-18 gauge, moisture-resistant, thermoplastic insulated wire with 105°C [221°F] minimum rating.
- Check ceramic flame rod insulator for cracks or evidence of exposure to extreme heat, which can permit leakage to ground. Replace pilot burner/igniter sensor and provide shield if necessary.
- If flame rod or bracket is bent out of position, restore to correct position.

STEP 3: Check spark ignition circuit.

Disconnect ignition cable at SPARK terminal on module.

⚠ WARNING

Electrical shock hazard. Ignition circuit generates over 10,000 volts. Turn OFF electrical power supply at service panel before making electrical connections. Failure to do so could result in death or serious injury.





Energize module and listen for audible sparking noise. When operating normally, there should be buzzing noise turns on and off twice per second for duration of 1–7 seconds, depending on model.

STEP 4: Verify pilot and main burner light-off.

- Initiate call for heat. Turn thermostat above room temperature. Ignition sequence may be delayed by thermal purge until boiler water temperature is below 140°F (60°C)
- Watch pilot burner during ignition sequence.
 - Verify ignition spark continues after pilot is lit.
 - Verify pilot lights and spark stops, verify main burner does not light.
- If so, ensure adequate flame current as follows.
 - Turn off boiler at circuit breaker or fuse box.
 - Clean flame rod with emery cloth.
 - Verify electrical connections are clean and tight. Replace damaged wire..
 - Check for cracked ceramic insulator, which can cause short to ground, and replace igniter-sensor if necessary.
 - At gas valve, disconnect main valve wire from MV terminal.
 - Turn on power and set thermostat to call for heat. Pilot should light, main burner will remain off because main valve actuator is disconnected.
 - Check pilot flame. Verify it is blue, steady and envelops 3/8 to 1/2 in. [10 to 13 mm] of flame rod. See Figure 19 for possible flame problems and causes.
 - If necessary, adjust pilot flame by turning pilot adjustment screw on gas control clockwise to decrease or counterclockwise to increase pilot flame. Following adjustment, always replace pilot adjustment cover screw and tighten firmly to assure proper gas control operation. Figure 14, page 19.
 - Set temperature below room set-point to end call for heat.
- Recheck ignition sequence as follows.
 - Reconnect main valve wire.

- Adjust thermostat above room temperature.
- Verify ignition sequence at burner.
- If spark does not stop after pilot lights, replace module.
- If main burner does not light or if main burner lights and system locks out, check module, ground wire and gas control as described in troubleshooting table. See Table 6 page 27, and Table 7 page 29.

Figure 19 - Troubleshooting Pilot Flame

APPEARANCE	CAUSE
<p>SMALL BLUE FLAME</p> 	<p>CHECK FOR LACK OF GAS FROM:</p> <ul style="list-style-type: none"> • CLOGGED ORIFICE FILTER • CLOGGED PILOT FILTER • LOW GAS SUPPLY PRESSURE • PILOT ADJUSTMENT AT MINIMUM
<p>LAZY YELLOW FLAME</p> 	<p>CHECK FOR LACK OF AIR FROM:</p> <ul style="list-style-type: none"> • DIRTY ORIFICE • DIRTY LINT SCREEN, IF USED • DIRTY PRIMARY AIR OPENING, IF THERE IS ONE • PILOT ADJUSTMENT AT MINIMUM
<p>WAVING BLUE FLAME</p> 	<p>CHECK FOR:</p> <ul style="list-style-type: none"> • EXCESSIVE DRAFT AT PILOT LOCATION • RECIRCULATING PRODUCTS OF COMBUSTION
<p>NOISY LIFTING BLOWING FLAME</p> 	<p>CHECK FOR:</p> <ul style="list-style-type: none"> • HIGH GAS PRESSURE
<p>HARD SHARP FLAME</p> 	<p>THIS FLAME IS CHARACTERISTIC OF MANUFACTURED GAS</p> <p>CHECK FOR:</p> <ul style="list-style-type: none"> • HIGH GAS PRESSURE • ORIFICE TOO SMALL

Correct Pilot Flame: 3/8 to 1/2 inch in flame. See Figure 15, Page 20.

B.1 Vent Damper Harness - Molex Plugs

⚠ WARNING

Do Not negate the action of any existing safety operational controls. Avoidance of these instructions could result in death or serious injury.

Note

When servicing controls, all wires must be labeled prior to disconnection. Wiring errors can cause improper and dangerous operation. Do not turn damper open manually or motor damage will result and void all warranties, use the service switch.

DO NOT CUT PLUG OFF OF DAMPER MOTOR ASSEMBLY OR WARRANTY WILL BE VOID.

Check Molex Plugs on Vent Damper Harness:

Note

Damper wiring harness is made up of 4 individual colored wires, Brown, Black, Yellow, and Orange (refer to drawing below).

1. Disconnect thermostat wires.
2. Use the two diagrams below to confirm the Molex plugs on each end of the damper harness are wired and operating properly.

Damper end of wiring harness:

- A. Hold plug in hand with wiring harness behind Molex with "V" slot on top. Verify wire colors are in proper position.
- B. Take reading across brown and black wires in Molex plug, using test meter set for AC volts. 24 volts should be present.
 - i. IF NOT, source of the problem is not in damper; check line voltage and 24 volt supply.
 - ii. If 24 volts is present across brown and black, continue to step iii.
 - iii. Reconnect thermostat wires and turn up heat setting.
 - iv. Check voltage across black and orange wires in Molex plug. 24 volts AC should be present:
 - IF NOT, source problem is not the damper.
 - If 24 volts is present continue on to step v.
 - v. Place jumper wire across orange and yellow wires in Molex plug (see Below). This will create bypass of the damper, boiler should then ignite.

- IF NOT, source problem is not the damper. Go to "Aquastat end of wiring harness"

- If boiler ignites: Go to section B.2 "Vent Damper Troubleshooting Guide".
NOTE: Prior to replacing the damper, be sure the problem is not with wire connections between damper and wiring harness.

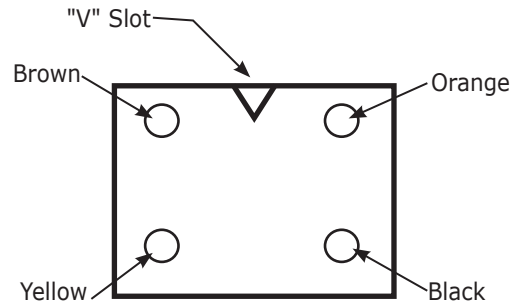

Control End of wiring harness

Hold plug in hand with wiring harness behind Molex with "V" slot on top. Verify wires colors are in proper position

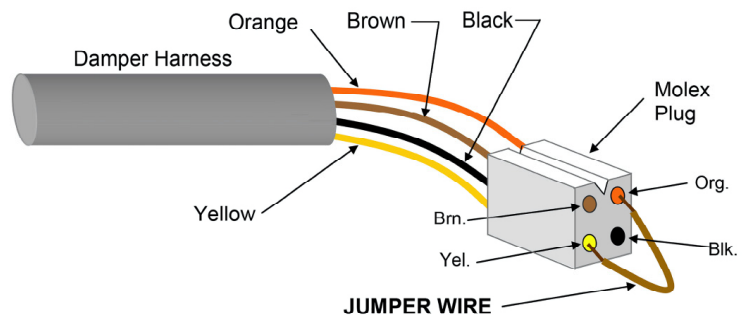
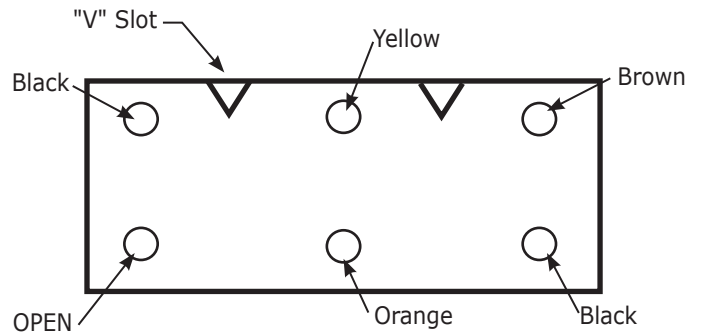

- A. Remove damper harness from control. Jump Molex connector on control board between two center holes using ~18ga. thermostat wire.
 - i. If boiler ignites, replace damper harness
 - ii. If boiler does not light, replace control.

B.2 Vent Damper Troubleshooting Guide

⚠ WARNING

Do Not negate the action of any existing safety operational controls. Avoidance of these instructions could result in death or serious injury.

Note

When servicing controls, all wires must be labeled prior to disconnection. Wiring errors can cause improper and dangerous operation. Do not turn damper open manually or motor damage will result and void all warranties, use the service switch.

DO NOT CUT PLUG OFF OF DAMPER MOTOR ASSEMBLY OR WARRANTY WILL BE VOID.

Normal Sequence of Operation

24 VAC Power	Power ON	Damper Position
4 & 1	All times	Open or Closed
4 & 2	Calling for Heat	Open or Opening
4 & 3	During combustion	Damper Open



Trouble Shooting

Problem	Possible Cause	Recommended Solution
NO POWER Between 4 & 1	<ol style="list-style-type: none"> 1. Off on limit (120VAC) 2. Bad transformer 3. Loose or broken connections 4. Blown fuse or circuit breaker 5. Disconnect switch off 6. Harness not plugged into receptacle 	<ol style="list-style-type: none"> 1. turn limit on 2. Replace transformer 3. Tighten, repair, or replace connection 4. Replace fuse or reset circuit breaker 5. Turn switch on 6. Plug harness in
NO POWER Between 4 & 2 POWER Between 4 & 1 When calling for heat	<ol style="list-style-type: none"> 1. Thermostat not calling for heat 2. Burned out heat anticipator 3. Loose or broken connections 4. Off/On operating limit, or low water cut off 5. Off/On blocked vent switch or flame roll out 	<ol style="list-style-type: none"> 1. Turn thermostat up to call for heat 2. Replace thermostat 3. Tighten, repair, or replace connection 4. Turn operating limit, or low water cutoff ON 5. Reset or replace switch
POWER Between 4 & 1 Between 4 & 2 DAMPER OPEN	<ol style="list-style-type: none"> 1. Loose or broken connection 2. Defective damper motor 	<ol style="list-style-type: none"> 1. Tighten, repair, or replace connection 2. Replace damper motor assembly

APPENDIX B - VENT DAMPER TROUBLESHOOTING

Note

For troubleshooting only. Verify damper is in open position. Use service switch to keep damper in open position. Place jumper between 2 & 3. If appliance fires, remove jumper and plug receptacle back into damper controller plug. If appliance does not fire, replace damper motor assembly. Do not replace pipe assembly.

If damper motor assembly is not available, place service switch in hold open position. This should keep damper in open position and allow customer to have automatic heat. Return or replace the motor assembly at your convenience. Motor assembly carries 18 month limited commercial warranty from the original date of purchase. (Refer to form #4294 on vent damper manufacturers website). Pipe assembly is not warranted.

Trouble Shooting with Jumper Wire In Place

Problem	Possible Cause	Recommended Solution
NO POWER Between 4 & 1 Between 4 & 2 Between 4 & 3 Damper OPEN NO COMBUSTION	<ol style="list-style-type: none"> 1. Is gas turned on 2. Operating limit, pressure control, low water cut off not on. 3. Blocked vent switch or flame roll out switch tripped 4. Loose or broken connection 5. Defective component in appliance after vent damper 	<ol style="list-style-type: none"> 1. Verify gas is on 2. Verify operating limit, pressure control or low water cut off is on 3. Reset or replace blocked vent switch or flame roll out switch 4. Tighten, repair, or replace connection 5. Replace defective component in appliance
Damper Sticks	<ol style="list-style-type: none"> 1. Damper blade obstruction 2. Damper pipe egg shaped, out of round/binding. 3. Crimped end of vent piece inserted in too far 	<ol style="list-style-type: none"> 1. Clear the obstruction 2. Restore to damper pipe to round, verify not binding. 3. Correct the condition
Damper Rotates Continuously	<ol style="list-style-type: none"> 1. Defective damper motor assembly 	<ol style="list-style-type: none"> 1. Replace damper motor assembly

IMPORTANT

In accordance with Section 325 (f) (3) of the Energy Policy and Conservation Act, this boiler is equipped with a feature that saves energy by reducing the boiler water temperature as the heating load decreases. This feature is equipped with an override which is provided primarily to permit the use of an external energy management system that serves the same function.

THIS OVERRIDE MUST NOT BE USED UNLESS AT LEAST ONE OF THE FOLLOWING CONDITIONS IS TRUE:

- An external energy management system is installed that reduces the boiler water temperature as the heating load decreases.
- This boiler is not used for any space heating
- This boiler is part of a modular or multiple boiler system having a total input of 300,000 BTU/hr or greater.
- This boiler is equipped with a tankless coil.



UTICA BOILERS
2201 Dwyer Avenue
Utica NY 13501

web site: www.ecrinternational.com