



BC Series II OIL-FIRED CAST IRON BOILER

INSTALLATION, OPERATION & MAINTENANCE MANUAL

FOR US AND CANADIAN SALES

**Models
BC3095
BC4100
BC4115**



Maximum Allowable
Working Pressure 30 psi.



Manufactured by:
ECR International Inc.
2201 Dwyer Avenue, Utica, NY 13501
Tel. 800 253 7900
www.ecrinternational.com
P/N 240011625, Rev. C [10/27/2017]

DIMENSIONS

Figure 1 - Dimensions

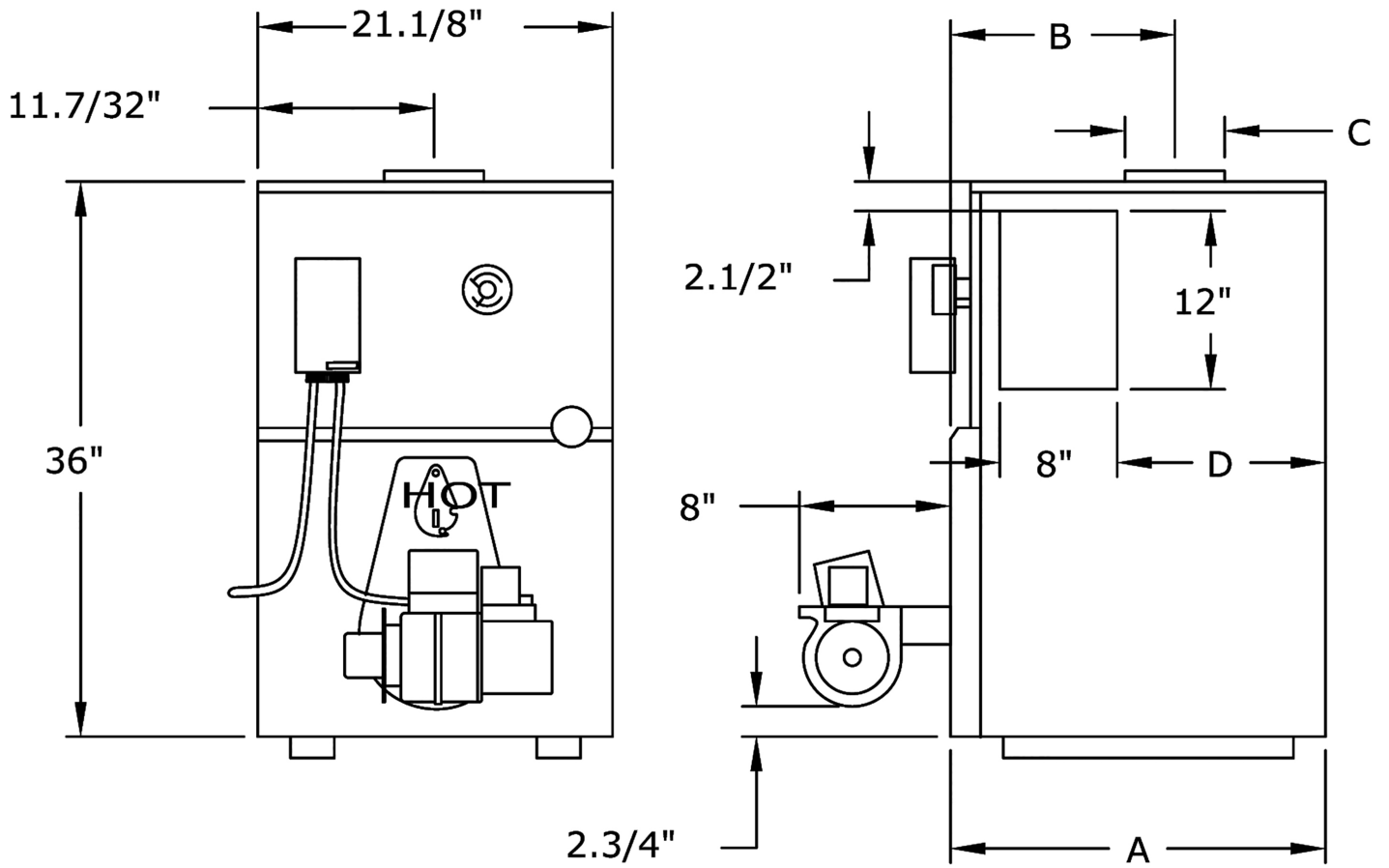

Table 1 DIMENSIONS				
Boiler No.	Length of Flush Jacket	Front of Jacket to Center Line of Flue Outlet	Flue Outlet Diameter	Tankless Coil to Back of Jacket
	-A-	-B-	-C-	-D-
BC3	19"	9 3/4"	6"	8 7/8
BC4	23"	11 3/4"	6"	12 3/4

SAFETY INFORMATION

Ratings, Data, And Dimensions.....	3
Installation Procedure	4
Ventilation And Combustion Air	5
Connecting Supply And Return Piping	7
Venting System Inspection & Installation.....	12
Electrical Wiring	14
Wiring Diagrams.....	15
Operating Instructions	16
Maintenance Procedures	18
Service Checklist	19

**KEEP THIS MANUAL NEAR BOILER
RETAIN FOR FUTURE REFERENCE**

**IMPORTANT: Read the following instructions
COMPLETELY before installing!!**

Safety Symbols & Warnings

The following defined symbols are used throughout this manual to notify the reader of potential hazards of varying risk levels.

DANGER

Indicates a hazardous situation which, if not avoided, WILL result in death or serious injury.

WARNING

Indicates a hazardous situation which, if not avoided, could result in death or serious injury.

CAUTION

Indicates a hazardous situation which, if not avoided, could result in minor or moderate injury.

NOTICE

Used to address practices not related to personal injury.

WARNING

All boiler and venting installations shall be done by qualified agency and in accordance with appropriate Manufacturer's Installation, Operation and Maintenance Manual. Installing or venting boiler or any other appliance with improper methods or materials could result in serious injury or death due to fire or to asphyxiation from poisonous gases such as carbon monoxide which is odorless and invisible.

WARNING

Keep boiler area clear and free from combustible materials, gasoline and other flammable vapors and liquids.

DO NOT obstruct air openings to the boiler room. Modification, substitution or elimination of factory equipped, supplied or specified components may result in personal injury or loss of life.

TO THE OWNER - Installation and service of this boiler must be performed by a qualified installer.

TO THE INSTALLER - Leave all instructions with boiler for future reference.

CAUTION

Laceration, burn hazard. Metal edges and parts may have sharp edges and/or hot. Use appropriate personal protection equipment to include safety glasses and gloves when installing or servicing this boiler. Failure to follow these instructions could result in minor or moderate injury.

RATINGS & DATA



Table 2 RATINGS & DATA

Boiler Model Number ⁽¹⁾	AHRI Oil Burner Input ⁽¹⁾		Heating Capacity MBH ⁽⁴⁾	AHRI Net Ratings ⁽²⁾⁽⁴⁾	A.F.U.E. Rating	Min. Natural Draft Chimney Size	
	G.P.H.	MBH ⁽⁴⁾		Water MBH		Round	Square
BC3095	0.95	133	114	99	84.0	6	8x8x15
BC4100	1.00	140	121	105	85.0	6	8x8x15
BC4115	1.15	161	137	119	84.0	6	8x8x15

NOTES:

1. AHRI burner capacity is based on an oil heating value of 140,000 Btu/gal and with 13% CO₂.
2. Net AHRI Water Ratings shown are based on a piping and pickup allowance of 1.15.
3. Consult manufacturer before selecting boiler for installations having unusual piping and pickup requirements, such as intermittent system operation, extensive piping.
4. For forced hot water heating systems where boiler and all piping are within the area to be heated, select boiler on basis of its Heating Capacity.
5. Nozzle listed for use with Beckett Burner.
6. Electrical service to be 120 Volts, 15 Amps, & 60 Hz.

Table 3 TANK-LESS WATER HEATER CAPACITIES

Boiler Model Number	Input Rate G.P.H.	Tankless Heater Number	Tankless Heater Capacity Intermittent Draw G.P.M.	Boiler Water Content (Gallons)
BC3095	0.95	L-24	3.25	6.7
BC4100	1.00	L-24	3.25	8.2
BC4115	1.15	L-24	4.00	8.2

STANDARD EQUIPMENT: Crated Boiler, Flush Jacket, Oil Burner, Target Wall/Liner, Circulator-1¼", Safety Relief Valve, Temperature Pressure Gauge, Drain Valve, Wiring Harness, Supply Tapping 1¼", Return Tapping 1¼", High Limit and Circulator Control, Primary Control. For Tankless Heater Units-add Low Limit.

INSTALLATION PROCEDURE

WARNING

Improper installation, adjustment, alteration, service or maintenance could result in death or serious injury.

- Installation shall conform to requirements of the authority having jurisdiction and shall take precedence over the general instructions of this manual.
- Where required by authority having jurisdiction, installation shall conform to Standard for Controls and Safety Devices for Automatically Fired Boilers, ANSI/ASME CSD-1.
- Locate boiler in front of final position before removing crate. Provide solid level base as near chimney as possible and centrally located with respect to the heat distribution system as practical.
- Allow 24 inches in front, top and right hand side for servicing and cleaning or removing tankless water heating coil.
- When installed in utility room, door should be wide enough to allow largest boiler part to enter, or to permit replacement of another appliance such as water heater.
- Boiler shall be installed such that the oil ignition system components are protected from water (dripping, spraying, rain etc.) during appliance operation and service.
- Remove crate and plastic protective wrapper, inspect for damage.
- Move boiler to permanent position by sliding or walking.

DANGER

Fire hazard. Do not install boiler on combustible flooring or carpeting. Failure to follow these instructions WILL result in death or serious injury.

Table 4 Clearance To Combustibles

TOP	24 IN.
FRONT	24 IN.
FLUE CONNECTOR	9 IN.
REAR	6 IN.
LEFT SIDE	6 IN.
RIGHT SIDE	24 IN.

NOTE: Clearance for access should exceed fire protection clearance.

Table 5 COMBUSTION AIR REQUIREMENTS
(Minimum Opening Requirement)

BTU/Hr Input (Mbh)	Unconfined Area*		Confined Area**	
	Outside	Inside	Outside Combustion Air	
	Combustion Air 1 Sq. In./5000 BTU/Hr (Step 4)	Combustion Air 1 Sq. In./1000 BTU/Hr (Min. 100 Sq. In.)	Vertical Ducts 1 Sq. In./4000 BTU/Hr (Figures 2 & 3)	Horizontal Ducts 1 Sq. In./2000 BTU/Hr (Figure 4)
133	27	133	33	67
140	28	140	35	70
161	32	161	40	81

* A space whose volume is not less than 50 cubic feet per 1000 BTU/Hour of all appliances installed in that space (cubic feet of space = height x width x length)

** A space whose volume is less than 50 cubic feet per Mbh of all appliances installed in that space (cubic feet of space = height x width x length)

⚠ WARNING

Asphyxiation, fire hazard. Air openings to combustion area SHALL not be obstructed. Provide adequate supply of combustion air in accordance with Installation Code for Oil Burning Appliances, CSA 139.

⚠ WARNING

Asphyxiation, fire hazard. Do not obstruct air openings to combustion area. Follow instructions below, to maintain adequate combustion air.

- When air for combustion and room ventilation is from inside buildings, the confined space shall be provided with two permanent openings, one starting 12 inches from the top and one 12 inches from the bottom of the enclosed space. Each opening shall have a minimum free area of 1 square inch per 1,000 BTU per hour of the total input rating of all appliances in the enclosed space, but must not be less than 100 square inches. These openings must freely communicate with the interior areas having adequate infiltration from the outside. See *Figure 2*.

- Ventilation of boiler room must be adequate enough to provide sufficient air to properly support combustion and venting.
- When the boiler is located in an unconfined space in a building of conventional construction frame, masonry or metal, infiltration normally is adequate to provide air for combustion and ventilation. However, in any building which has been altered to conserve energy or to minimize infiltration, the boiler area should be considered as a confined space. If there is any doubt, install air supply provisions for combustion and ventilation in accordance with requirements of authority having jurisdiction, or in absence of such requirements, Air for Combustion and Ventilation of the NFPA 31.
- When the boiler is installed in an unconfined space, in a building of unusually tight construction, air for combustion and room ventilation must be obtained from outdoors or from spaces freely communicating with the outdoors. A permanent opening or openings having a total free area of not less than 1 square inch per 5,000 BTU per hour of total input rating of all appliances shall be provided. Ducts may be used to convey make-up air from the outdoors and shall have the same cross-sectional area of the openings to which they are connected.

Figure 2 Combustion and Room Air From Inside Buildings

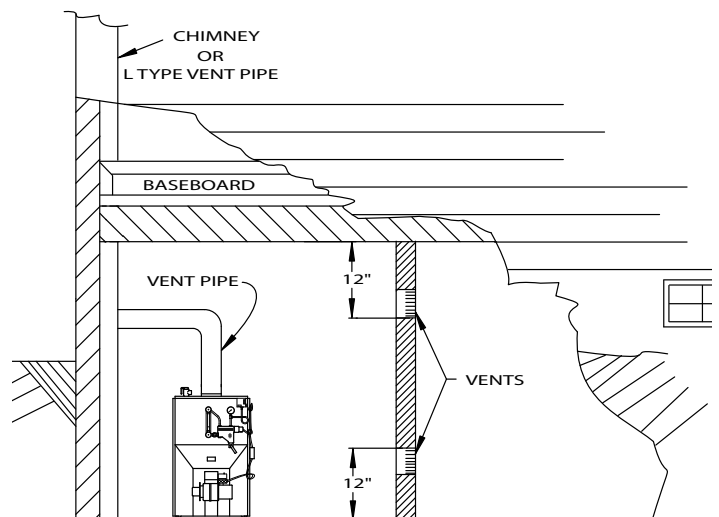

5. When the boiler is installed in a confined space and all air is provided from the outdoors, the confined space shall be provided with two permanent openings, one commencing within 12 inches from the top and one commencing 12 inches from the bottom of the enclosure. The openings shall communicate directly, or by ducts, with the outdoors or spaces (crawl or attic) that freely communicate with the outdoors. One of the following methods must be used to provide adequate air for ventilation and combustion.
 - A. When directly communicating with the outdoors, each opening shall have a minimum free area of 1 square inch per 4,000 BTU per hour of total input rating of all equipment in the enclosure. See Figure 3.
 - B. When communicating with the outdoors by means of vertical ducts, each opening shall have a minimum free area 1 square inch per 4,000 BTU per hour of total input rating of all appliances in the enclosed space. See Figure 4.
 - C. If horizontal ducts are used, each opening shall have a minimum free area 1 square inch per 2,000 BTU per hour total input rating of all appliances in the enclosed space. See Figure 5.
 - D. When ducts are used, they shall be of the same cross sectional area as the free area of the area of the openings to which they connect. The minimum dimension of rectangular air ducts shall not be less than 3 inches.
6. In calculating free area using louvers, grills or screens for the above, consideration shall be given to their blocking effect. Screens used shall not be smaller than 1/4 inch mesh. If the free area through a design of louver or grill is known, it should be used in calculating the size opening required to provide the free area specified. If the design and free area is not known, it may be assumed that wood louvers will have 20-25% free area and metal louvers and grills will have 60-75% free area. Louvers and grills shall be fixed in the open position or interlocked with the boiler so that they are opened automatically during boiler operation.

Figure 3 Boiler Installed In Confined Space - Air From Outdoors

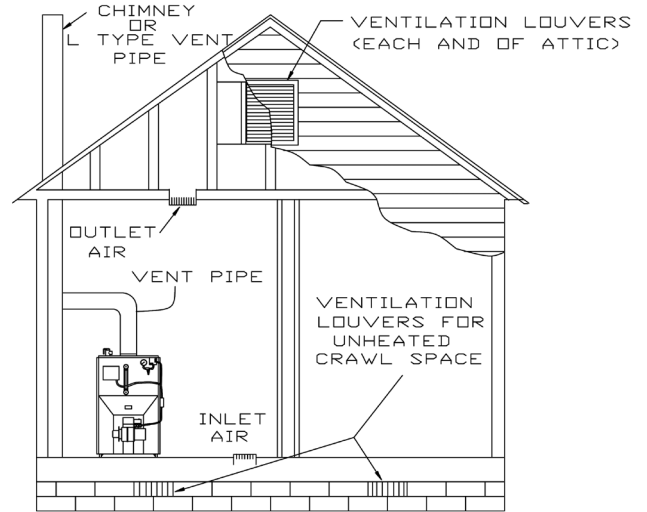

Figure 4 Vertical Ducts

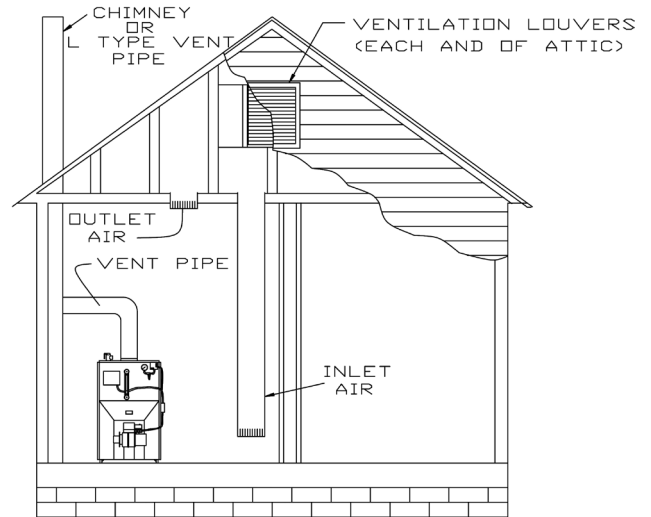
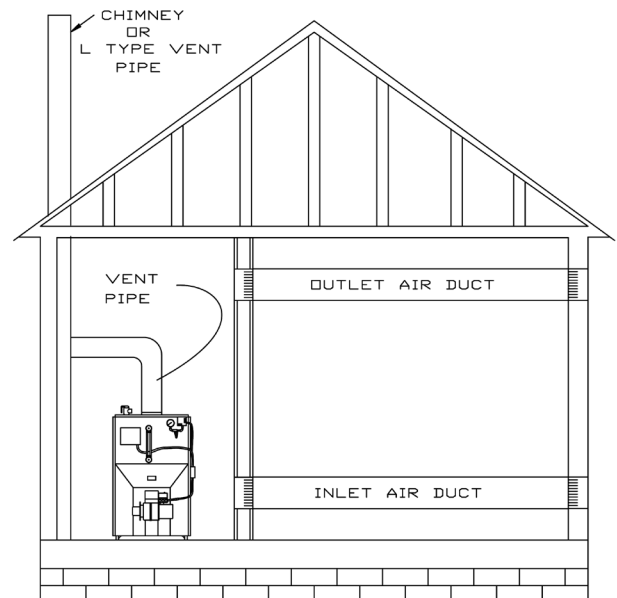

Figure 5 Horizontal Ducts



CONNECTING SUPPLY AND RETURN PIPING

Circulators in the following illustrations are mounted on system supply side, mounting on system return side is also acceptable practice.

Figure 6 Boiler Used In Connection With Refrigerated System

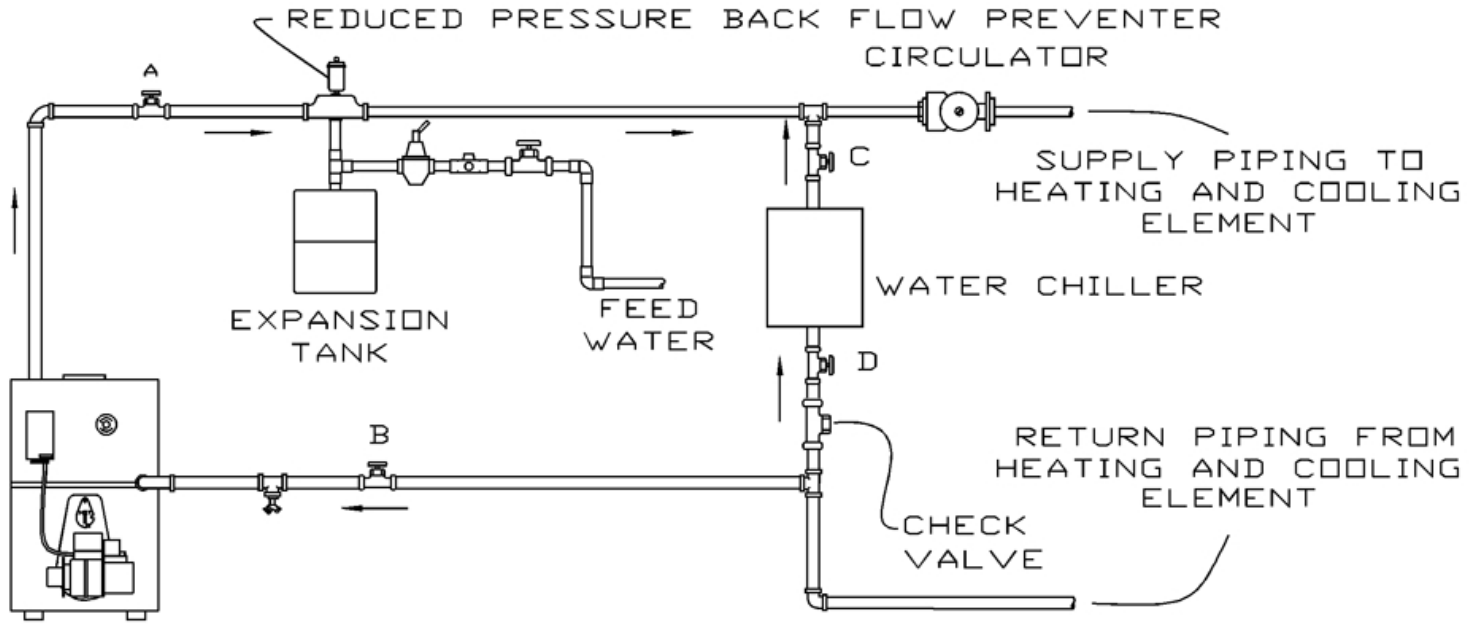
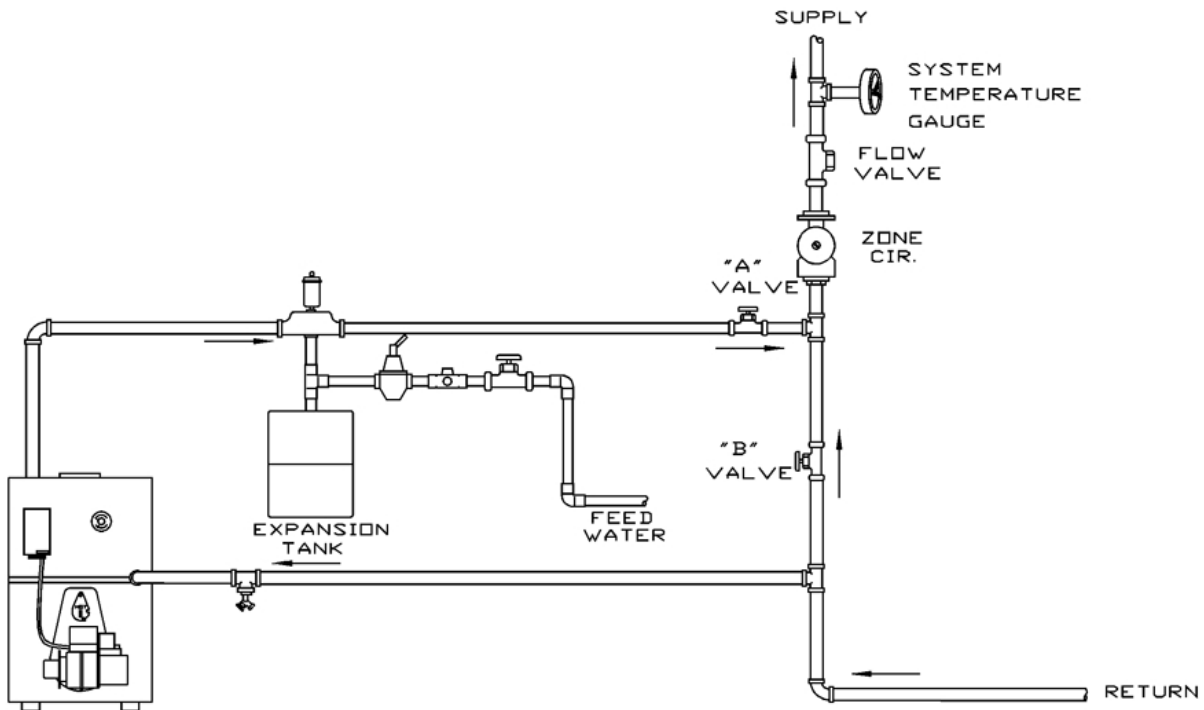

Figure 7 Bypass Piping Typically Used With Baseboard Heating



1. Connect supply and return piping as suggested in Figure 6. When the boiler is used in connection with refrigerated systems:
 - A. Chilled medium **MUST BE IN PARALLEL** with boiler.
2. During the heating cycle open valves **A** and **B**, close valves **C** and **D**.

CONNECTING SUPPLY AND RETURN PIPING

3. During heating cooling cycle open valves **C** and **D**, close valves **A** and **B**.
 - A. Maintain a minimum clearance of one (1") inch to hot water pipes. In air handling units where they may be exposed to refrigerated air circulation, the boiler piping system **MUST** be supplied with flow control valves or other automatic means to prevent gravity circulation of the boiler water during the cooling cycle.
4. Hot water boilers installed above radiation level must be provided with a low water device either as part of the boiler or at the time of boiler installation.
5. When a boiler is connected to a heating system that utilizes multiple zoned circulators, each circulator must be supplied with a flow control valve to prevent gravity circulation.

* Reduced pressure back flow preventer must be present under provisions required by the Environmental Protection Agency, (EPA).
6. Bypass piping is an option which gives the ability to adjust the supply boiler water temperature to fit the system or condition of the installation. Although, this method of piping is not typically required for baseboard heating systems.
 - A. This method is used to protect systems using radiant panels and the material they are encased in from high temperature supply water from the boiler. See *Figure 7, page 7*.
 - B. This method is used to protect boilers from condensate forming due to low temperature return water. Generally noticed in large converted gravity systems or other large water volume systems. See *Figure 8*.
 - C. This method is used to protect boilers from condensate forming as well as protecting the heating system from high water temperature. See *Figure 9, page 9*.
7. **Note:** When using bypass piping, adjust valves **A** and **B** until desired system temperature is obtained.
8. Bypass loop piping must be same size piping for supply and return.
9. Typical installation using circulators is shown in **Figure 10, page 9**.
10. Typical installation using zone valves is shown in *Figure 11, page 10*.
11. See *Figure 12, page 10* for typical piping for domestic hot water heater.

Figure 8 Bypass Piping Option For Converted Large Volume Systems

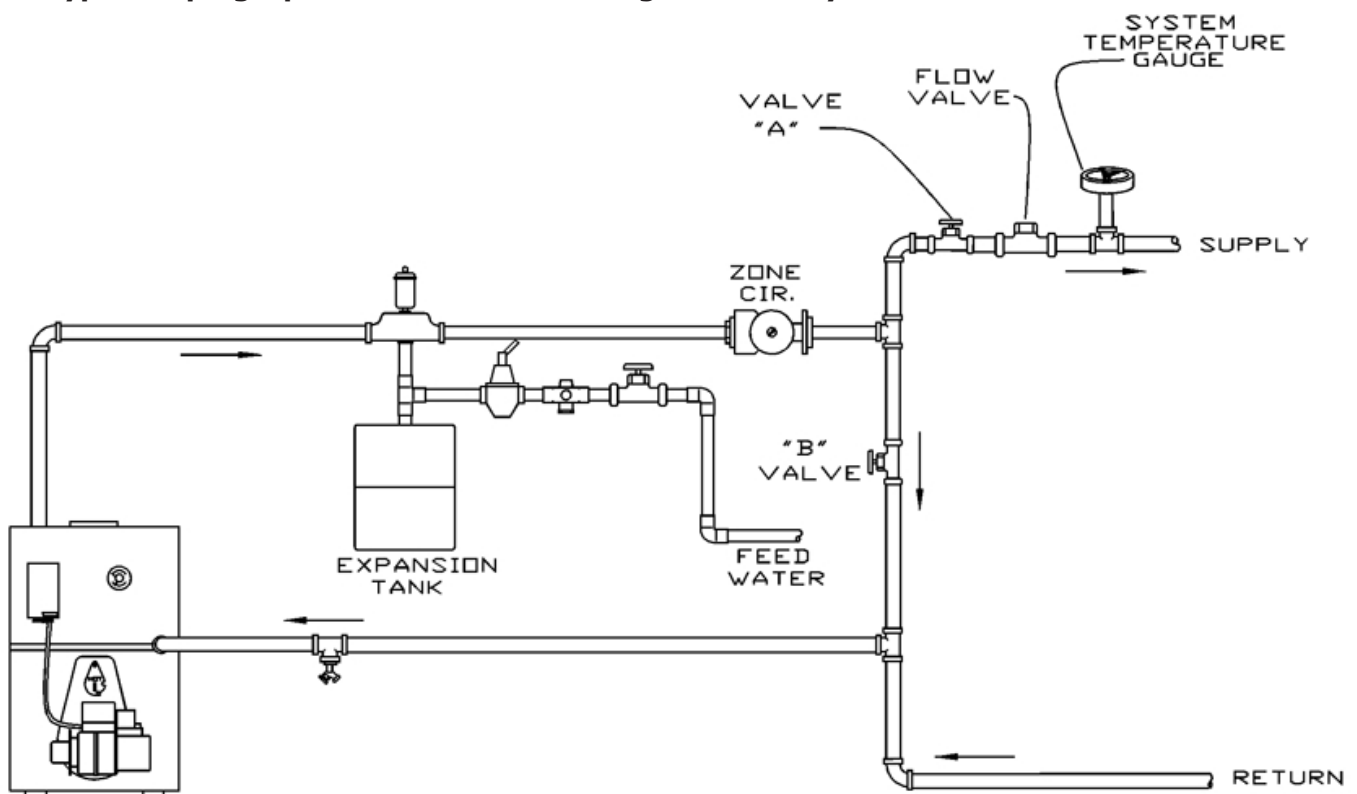

CONNECTING SUPPLY AND RETURN PIPING

Figure 9 Bypass Piping Option Used to Protect From Converted Systems With High Water Temperature

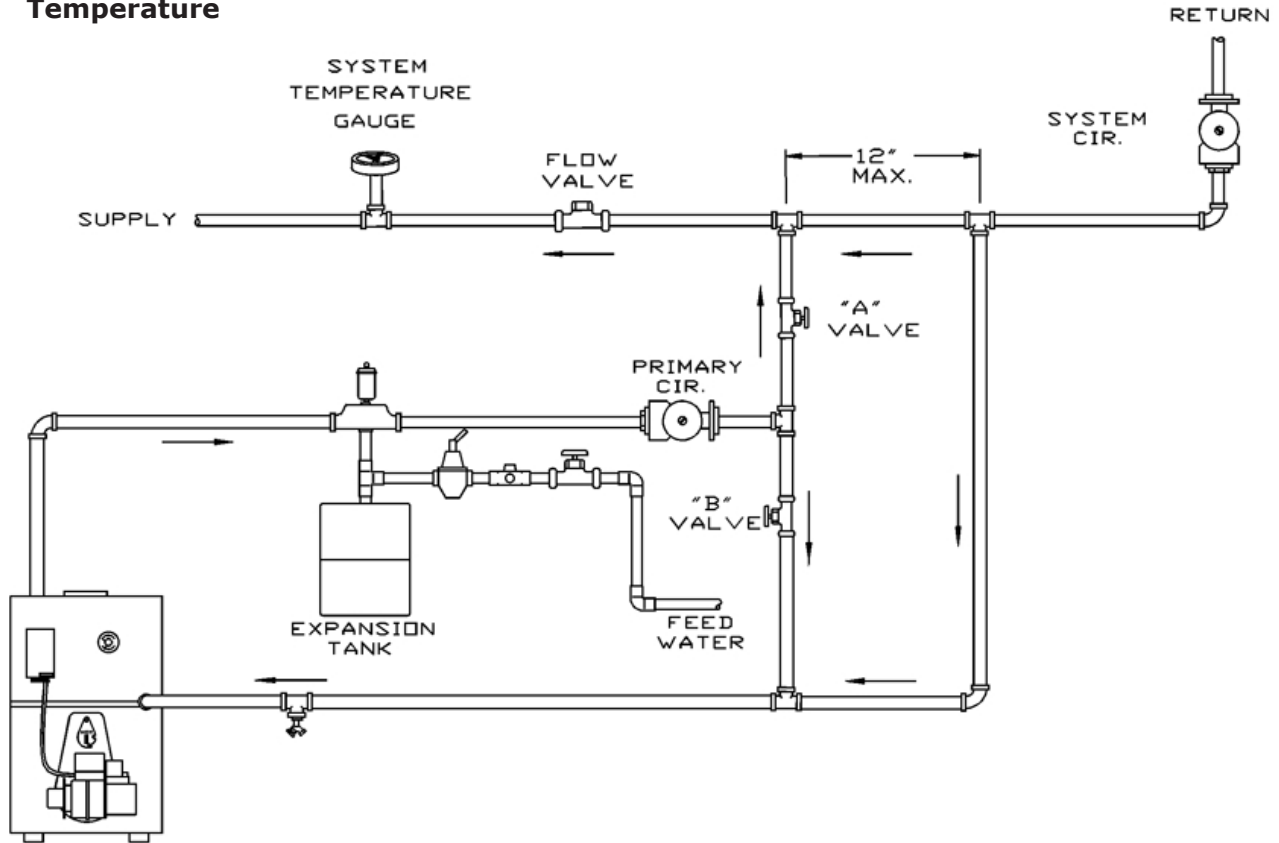
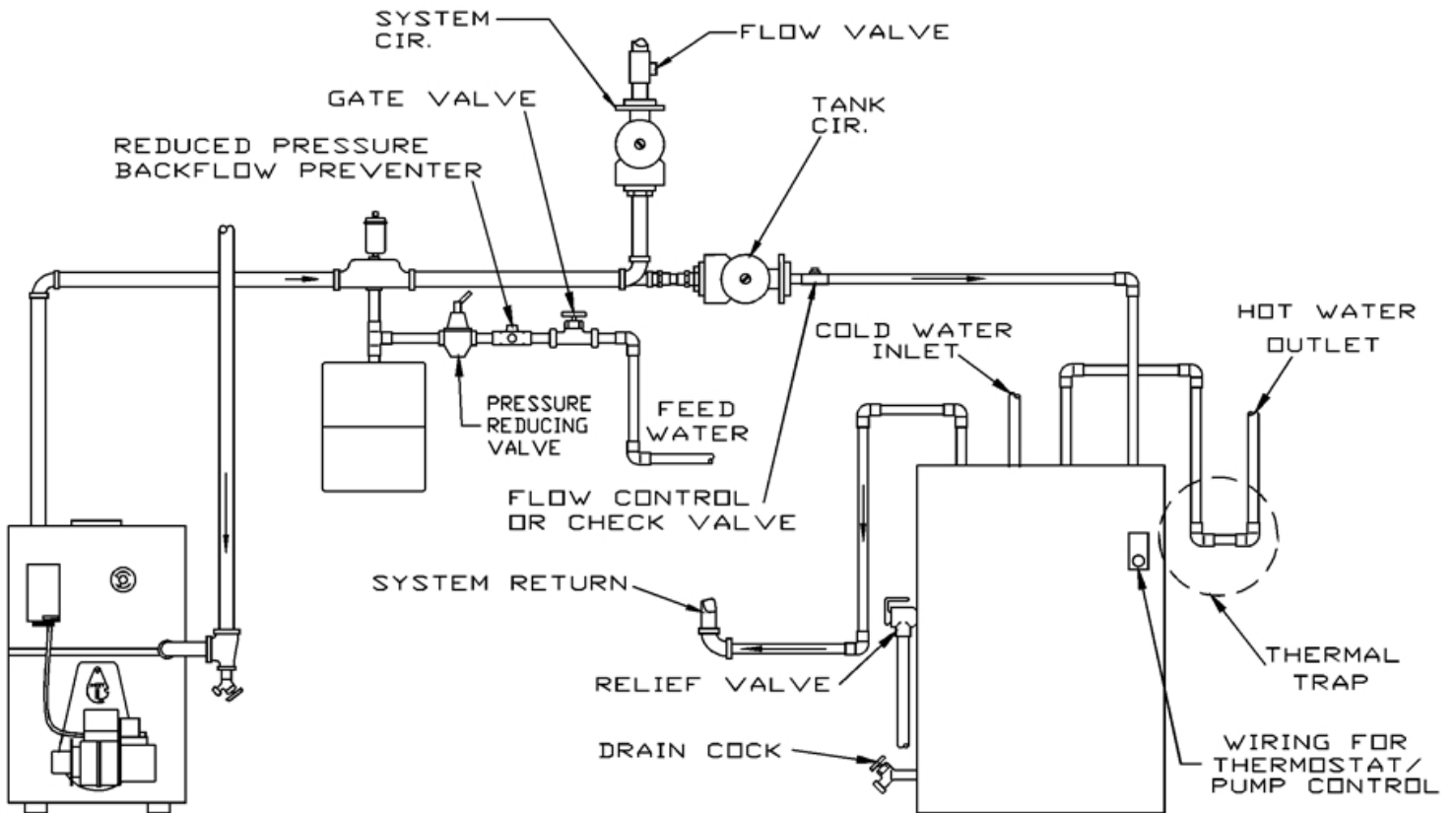

Figure 10 Typical Installation With Circulators



CONNECTING SUPPLY AND RETURN PIPING

Figure 11 Typical Installation With Valves

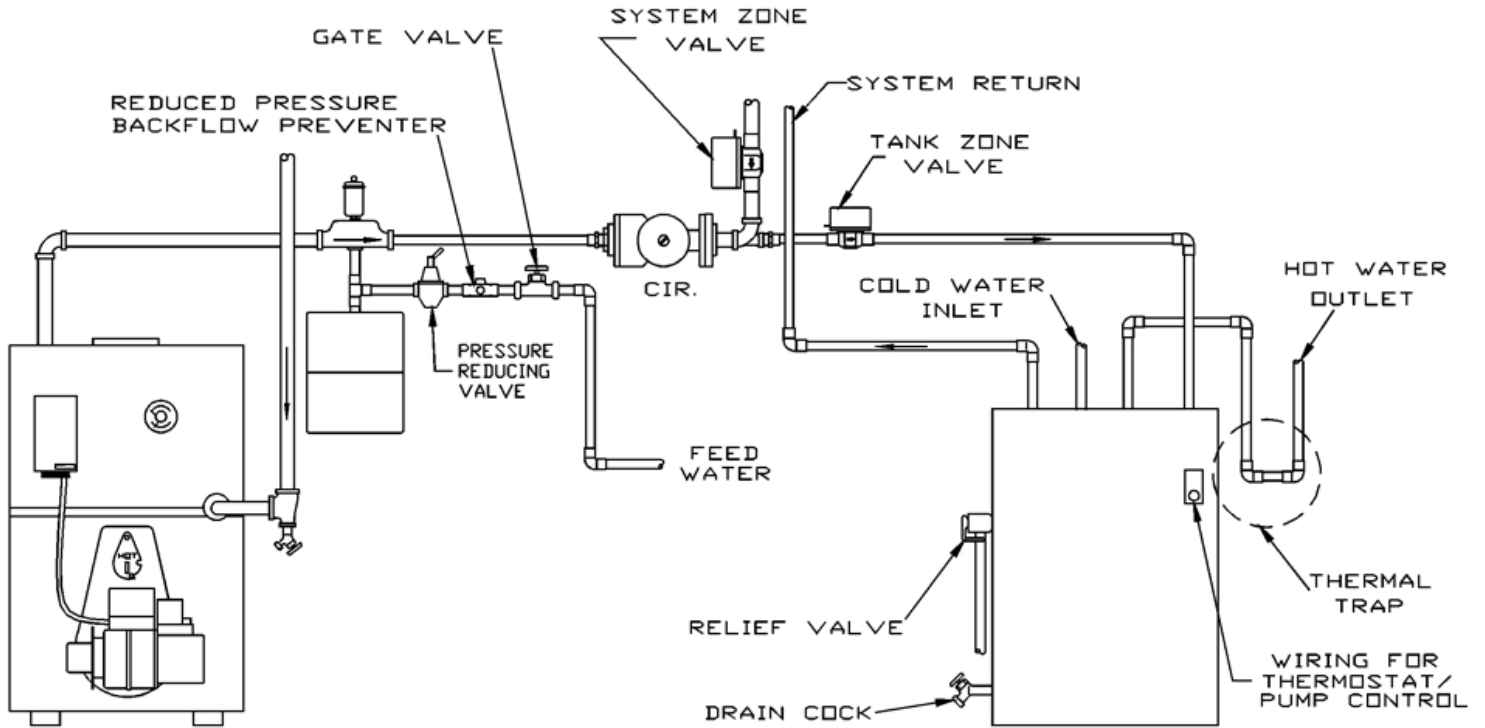
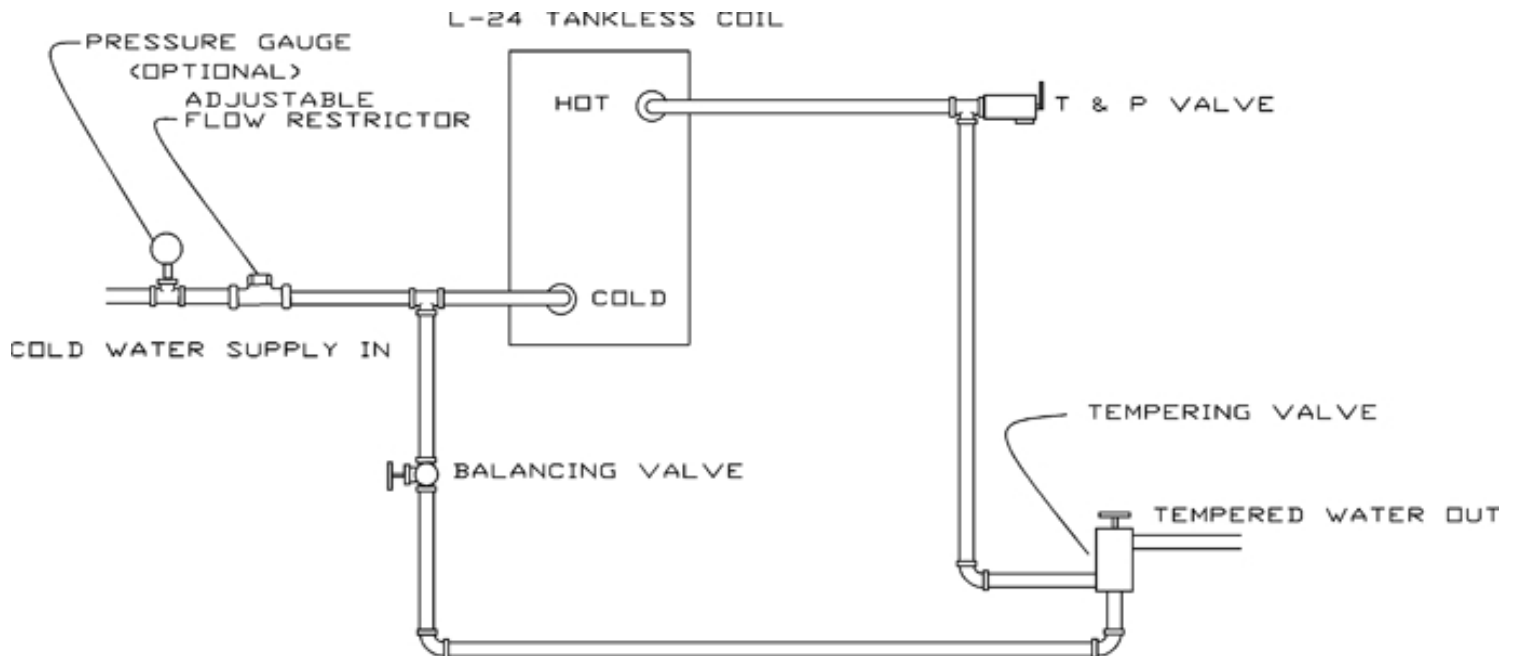

Figure 12 Typical Installation With DHW



⚠ **WARNING**

Burn or Scald Hazard. Discharge line shall be installed to relief valve outlet connection to avoid burns, scalding, or water damage due to discharge of steam and/or hot water during operation.

Discharge line shall:

- Use ¾" or larger pipe.
- Use pipe suitable for temperatures of 375°F (191°C) or greater.
- Individual boiler discharge piping shall be independent of other discharge piping.
- Size and arrange discharge piping to avoid reducing safety relief valve relieving capacity below minimum relief valve capacity stated on rating plate.
- Run pipe as short and straight as possible to location protecting user from scalding and properly drain piping.
- Install union, if used, close to safety relief valve outlet.
- Install elbow(s), if used, close to safety relief valve outlet and downstream of union (if used).
- Terminate pipe with plain end (not threaded).

Refer to local codes and appropriate ASME Boiler and Pressure Vessel Code for additional installation requirements.

12. Install limit sensor in supply pipe. See Figure 13.

- Install nipple and tee.
- Install well in tee.
- Insert sensor into well. Secure with clip.
- Secure sensor wire to jacket with cable clamps.
- Plug sensor wire into limit. See wiring diagram.

13. Install safety relief valve. See Figure 14.

- Install safety relief valve in rear section using provided nipple and elbow.
- Install discharge piping. Follow instructions in Warning above.

Figure 13 Limit Sensor

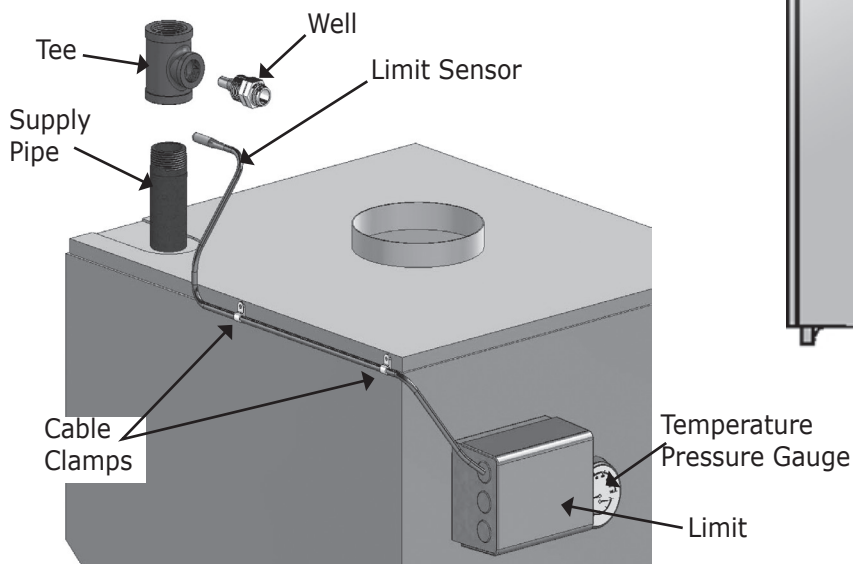
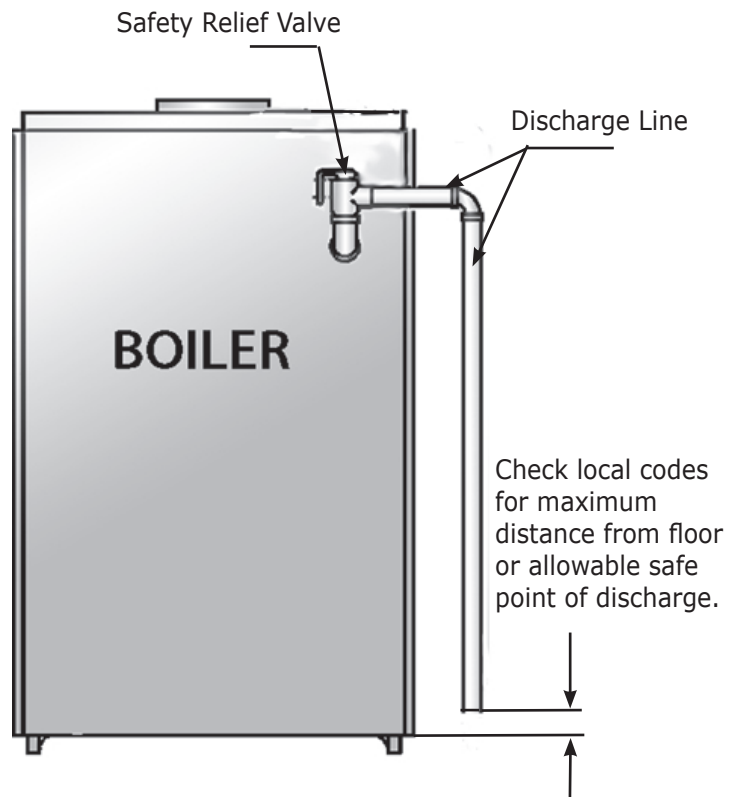

Figure 14 Safety Relief Valve With Discharge Line



⚠ WARNING

Boiler and venting installations shall be performed by a qualified expert and in accordance with the appropriate manual. Installing or venting boiler or other appliances with improper methods or materials may result in serious injury or death due to fire or to asphyxiation from poisonous gases such as carbon monoxide which is odorless and invisible.

⚠ WARNING

Do not connect boiler to any portion of mechanical draft system operating under positive pressure.

Figure 15 Chimney Installation

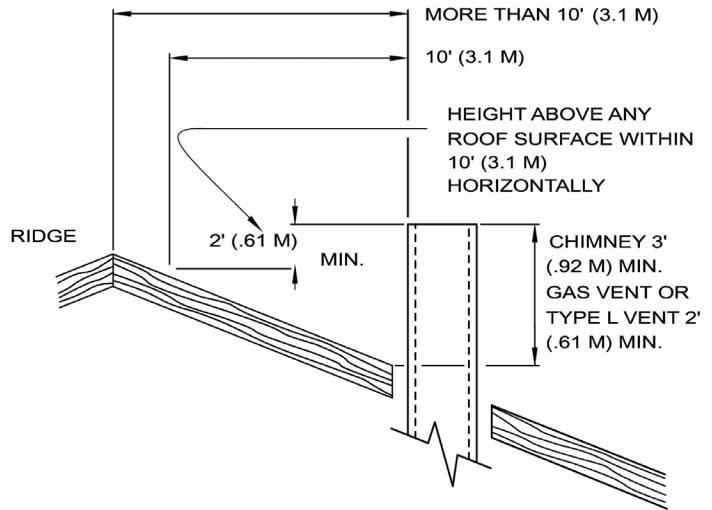

- Inspect chimney. Verify construction supplies with requirements of authority having jurisdiction, or in absence of such requirements, NFPA 211: Standard for Chimneys, Fireplaces, Vents and Solid Fuel-Burning Appliances.
- Install boiler into chimney which has masonry or metallic chimney liner.
- Unlined chimney will have leaks that will cause poor chimney performance (no draft), and could result in positive pressure in the combustion chamber.
- Horizontal portions of venting system should not exceed 10 ft. in length. Horizontal lengths over 10 ft. will have negative effect on chimney performance.
- Chimney should extend at least 2 ft. above any portion of building within 10 ft. See *Figure 15*. It should produce a -.06 to -.08 inch W.C. draft, as measured with draft gauge between boiler and barometric draft control while maintaining .02 inch W.C. negative draft in combustion chamber. See "Chimney or Vent Sizes" chart for recommended minimum and maximum chimney or vent sizes.
- Inadequate draft will cause improper combustion, resulting in dirty flue ways and high fuel bills.
- Connect flue pipe same size as boiler outlet to chimney, sloping upward continuously toward the chimney approximately 1/4" per foot. Bolt or screw joints together to avoid sag.
- If oil fired water heater is vented into same flue as boiler, provide separate hole into chimney whenever possible. When this isn't possible, use "Y" connection in flue pipe, using separate draft regulator for each unit. When chimney will not provide adequate draft to handle input from water heater and boiler simultaneously, wire units so only one will operate at a time, favoring water heater.
- Blocked vent safety switch required in Canada. See *Figure 16*.

Table 6 CHIMNEY OR VENT SIZES

MODEL NUMBER	ROUND INCHES		SQUARE INCHES		HEIGHT (FT)	
	MIN	MAX	MIN	MAX	MIN	MAX
BC4	6	8	8x8	8x10	15	40

OIL TANK AND PIPING

Oil Tank and Piping Installation

- Install oil tank and piping in accordance with the National Board of Fire Underwriters and local regulations.
- Oil storage tank, vent, fill pipe and caps should be as prescribed by local codes. In no case should the vent pipe be smaller than 1¼" I.P.S. The fill pipe should not be less than 2" I.P.S.
- Suction line from tank to burner shall be one continuous piece of tubing to prevent air entering the line.
 - A. Suction line, must be ¾" O.D. copper tubing for runs of 50 feet or less, and ½" O.D. for longer runs.
 - B. Install oil return line same size suction line. Use on any installation where bottom of tank is below fuel unit of burner.
 - C. Oil lines should be buried or otherwise protected from mechanical injury.
 - D. Flare fittings on all oil lines are recommended.
 - E. Compression fittings on suction line often allows air to be drawn into fuel pump, making it difficult to maintain oil pressure at the nozzle.
 - F. Do not run overhead fuel lines from tank to oil burner.

- Install fuel pump connections and by-pass according to instructions attached to the fuel pump. If tank is more than 20' from boiler, install two stage fuel unit in place of single stage pump supplied as standard equipment with burner. Verify rotation and speed are same and pump is suitable for burner horsepower rating.
- Install oil line filter and shut-off valve in suction line. Install shut-off valves in both suction and return lines at burner for servicing burner. Allow extra tubing at burner so burner may be removed from boiler for cleaning without disconnecting tubing. See Figure 16 and Figure 17. Optional flexible oil line is available.

Figure 16 Typical Installation Single Pipe Oil System

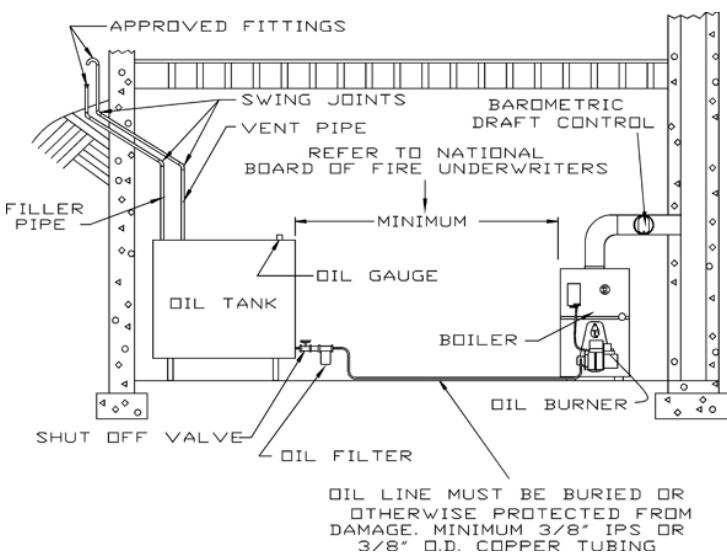
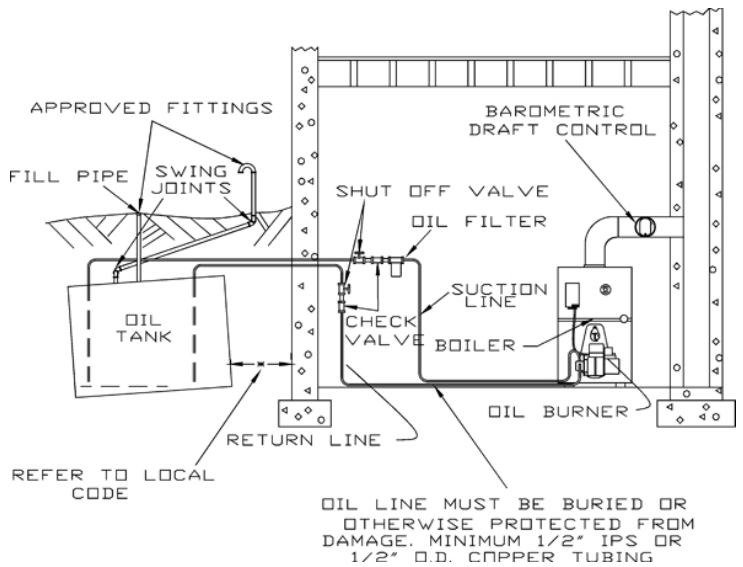

Figure 17 Typical Installation Two Pipe Oil System



WARNING

Electrical shock hazard. Turn OFF electrical power supply at service panel before making electrical connections. Failure to do so could result in death or serious injury.

Install electrical wiring in accordance with requirements of authority having jurisdiction, or in the absence of such requirements, NFPA 70: National Electric Code.

A separate electrical circuit should be run from the entry box with a fused disconnect switch in this circuit. See wiring diagram See Figure 18 .

Wiring for zone valve installations are furnished with zone valve packages.

Thermostat Installation

1. Thermostat should be installed on an inside wall about four feet above the floor.
2. **NEVER** install a thermostat on an outside wall.
3. Do not install a thermostat where it will be affected by drafts, hot or cold pipes, sunlight, lighting fixtures, television, fireplaces, or chimneys.
4. Check thermostat operation by raising and lowering thermostat as required to start and stop the burner.
5. Instructions for the final adjustment of the thermostat are packaged with the thermostat (adjusting heating anticipator, calibration, etc.).

Figure 18 Wiring Diagram

HOT WATER CONTROL WIRING FOR OIL FIRED BOILERS
(HOT CÂBLAGE CONTRÔLE DE L'EAU POUR AU MAZOUT CHAUDIÈRES)

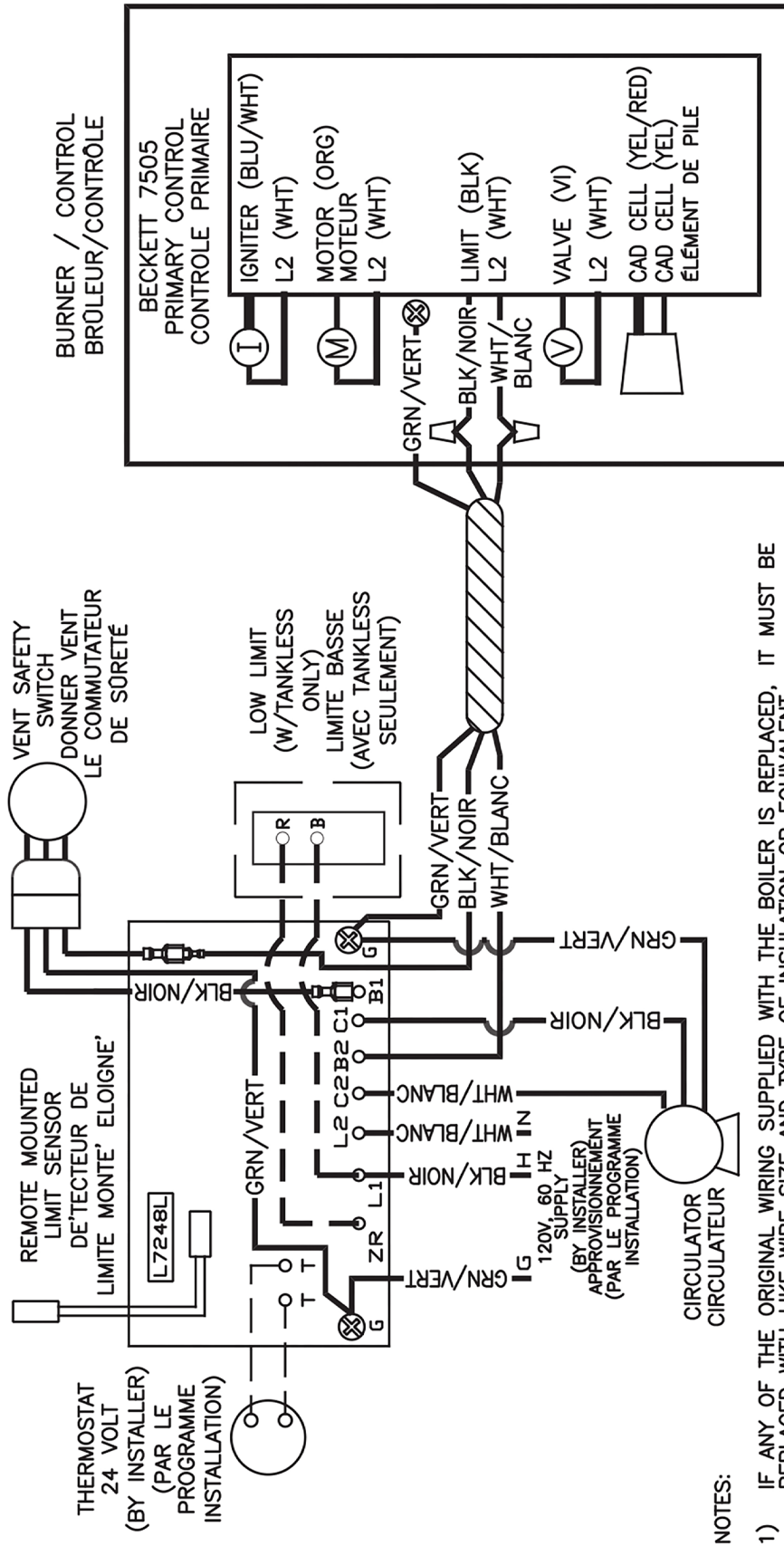

NOTES:

- 1) IF ANY OF THE ORIGINAL WIRING SUPPLIED WITH THE BOILER IS REPLACED, IT MUST BE REPLACED WITH LIKE WIRE SIZE AND TYPE OF INSULATION OR EQUIVALENT.
(SI DES FILS ORIGINALEMENT FOURNIS AVEC LA CHAUDIÈRE SONT REMPLACÉS, ILS DOIVENT ÊTRE REMPLACÉS PAR DES FILS DE MÊME GROSSEUR ET DE MÊME TYPE D'ISOLANT OU L'ÉQUIVALENT.)
- 2) WHEN LOW LIMIT IS USED, SET "ELL" PARAMETER ON L7248L CONTROL TO ON.
BOILERS FACTORY EQUIPPED WITH TANKLESS COIL ARE FACTORY SET TO ON.
(LORSQUE LA LIMITE INFÉRIEURE EST UTILISÉE, CONFIGURER LE PARAMÈTRE ELL DE LA COMMANDE HONEYWELL L7248 A' ON (EN MARCHÉ). LES CHAUDIÈRES MUNIES EN USINE DE SERPENTIN CHAUFFE-EAU SONT DE'JA' RE'GLÉES A' ON (EN MARCHÉ).)

OPERATING INSTRUCTIONS

Sequence of Operation

- Thermostat calls for heat.
- Circulator turns on.
- Limit checks boiler water temperature. Burner ignition delayed until limit determines call for heat cannot be met by residual heat in boiler and heat distribution system.
 - A. See limit literature for additional information.
 - B. Burner delay by-passed for tankless heat call for heat. Burner ignition begins immediately.
- Burner and circulator operation continues until thermostat stops call for heat.

Figure 19 Boiler Controls

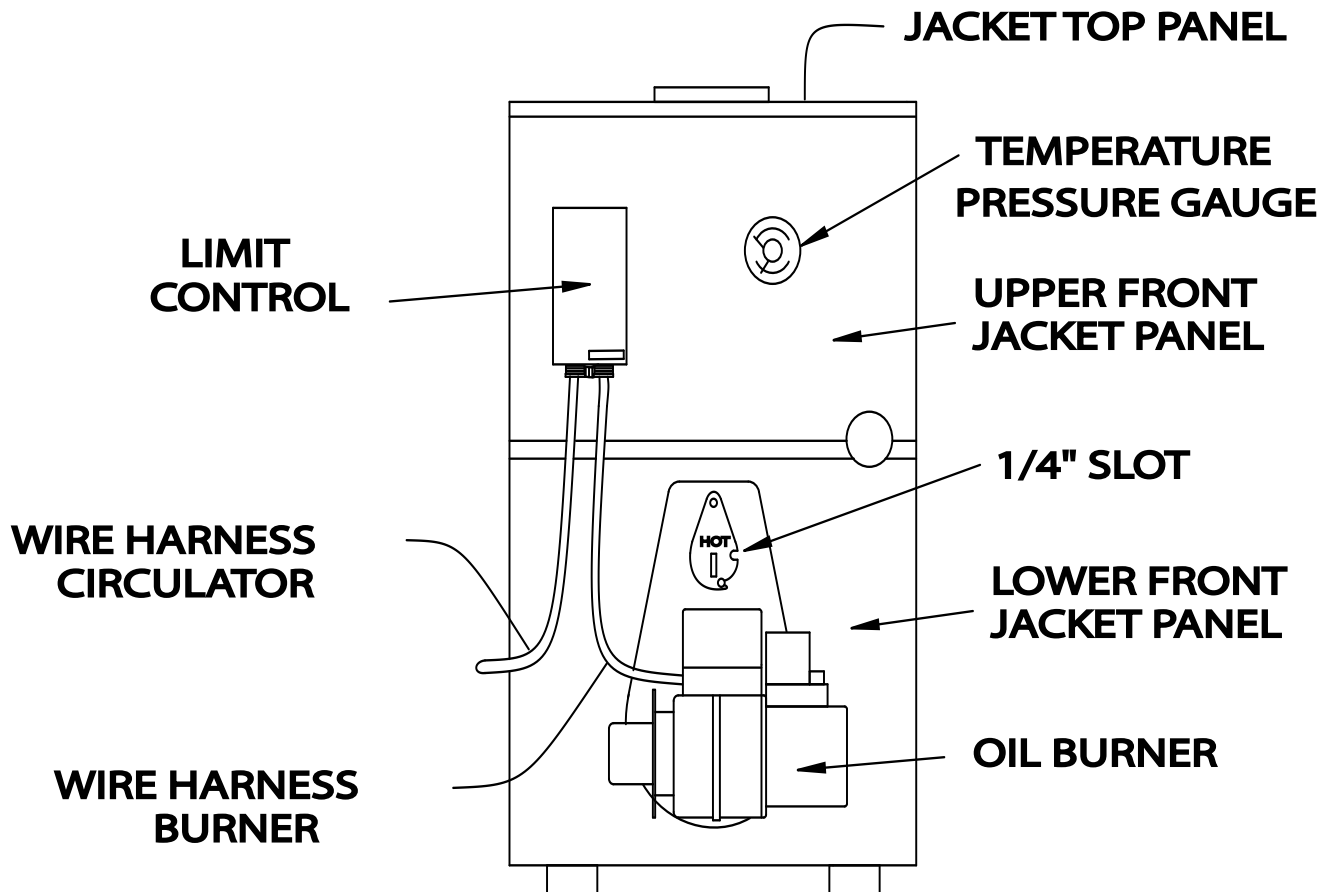

OPERATING INSTRUCTIONS

WARNING

Boiler and venting installations shall be performed by a qualified expert and in accordance with the appropriate manual. Installing or venting boiler or other appliances with improper methods or materials may result in serious injury or death due to fire or to asphyxiation from poisonous gases such as carbon monoxide which is odorless and invisible.

Start-Up And Adjustment Of Oil Burner

NOTE: Bacharach or Dwyer test kits include these instruments.

(See oil burner instructions for nozzle and electrode setting)

1. Verify oil burner nozzle is tight in adapter. Burner mounting bolts should be tight.
2. Check electrode setting, may have been jarred out of position during transportation.
3. Lubricate burner motor if necessary.
4. Set room thermostat to call for heat, or jump thermostat contacts on boiler control.
5. Open all oil line valves.
6. Turn service switch on. Burner will start.
7. On one pipe fuel systems only, bleed pump as soon as burner starts. Allow oil to run until all traces of air in suction line disappear.
8. Turn "OFF" burner and install pressure gauge port on pump.
9. Start burner and check oil pressure for 140 psi adjust if necessary.

Burner Operation Instructions

- Use provided ¼" diameter slot in inspection cover plate to take draft readings in combustion chamber. See *Figure 19, page 16.*
- Drill ¼" diameter hole in flue pipe between boiler and barometric damper (if used) to take draft, CO₂, smoke and temperature readings. Plug hole when done.
- Adjust air shutter on oil burner to obtain "trace" of smoke. Measure CO₂ at this point.
- Increase air adjustment to lower CO₂ approximately one percent.
- Verify minimum negative .02 w.c., (water column), "overfire" draft and zero smoke.
- If -.02 w.c. "overfire" draft can not be maintained, changes and/or modifications may be required in venting or chimney.
- See table below as guideline for initial start-up. Make final adjustments using combustion instruments.

Check safety control circuit after burner adjustments have been made for satisfactory performance.

- A. High limit control: remove cover and note temperature setting. See *Figure 19, page 16.* With burner operating, decrease setting to minimum point. When boiler water temperature exceeds set point, high limit switch will open, shutting off power to oil burner. Return setting to desired high limit point. Burner should start.
- B. Verify Primary Control and Flame Sensor -
 - **Flame Failure** - simulate by shutting off oil supply with hand valve while burner is on. Sixty seconds after flameout, safety switch locks out, ignition stops, motor stops and oil valve - when used - closes. To restart, open oil supply valve and reset safety switch.
 - **Ignition Failure** - With burner off, close oil supply valve and run through start-up procedure. Safety switch should lock out as in flame failure.
 - **Power Failure** - Turn off main power supply switch while burner is operating. When burner stops, restore power and burner should start. If operation is not as described as above, check wiring and controls.

Table 7 Oil Burner Settings

Boiler Model No.	Head Type	Static Disc	Air Band Settings	Air Shutter Settings	Nozzle Furnished	Pump Pressure (psi)
	F3	2¾ U	0	6	Delevan 0.85x 80°B	140
BC4100	F3	2¾ U	0	7	Delevan 0.85x 80°B	140
BC4115	F6	2¾ U	0	6	Delevan 1.00x 80°B	140

NOTES:

Information in above table uses Beckett model AFG burner for both model numbers BC3095 and BC4100

BC4115 is rerated boiler which requires rerate kit.

Regular Maintenance

- Inspect venting system at start of each heating season. Check vent pipe from boiler to chimney for signs of deterioration by rust or sagging joints. Repair if necessary.
- Remove vent pipe at base of chimney or flue. Use mirror, check for obstruction.
- Verify compliance to the latest revision of the NFPA 211.
- Operate lever of safety relief valve on boiler periodically to verify that it is functioning properly. Open pressure relief valve before water pressure exceeds 30 psi reading on gauge. If pressure is exceeded and pressure relief valve leaks water when boiler is operating at normal pressures, replace immediately. Corrosion can build at valve seat and prevent functioning as safety device.

Annual Inspection - Before Start of Heating Season

Periodically or at start of heating season inspect boiler, vent and vent pipe for accumulation of soot or scale deposits. When soot is present on section walls and flueways, improper combustion results, causing additional sooting and scaling until flueways are completely closed.

- A. To remove soot and scale from flueways, remove top jacket panel, top clean-out plate and burner. See instructions on Removing Oil Boiler. Use wire brush, brush soot and scale into combustion chamber where it can be removed through burner opening.
- B. Carefully vacuum debris from combustion chamber. Inspect combustion chamber for signs of damage, i.e. cracks.
- C. In event combustion chamber is damaged, contact qualified service agent to replace immediately.

NOTICE

Do not overtighten bolts.

Periodic inspection and tightening of tankless heater/ cover plate bolts reduce the risk of leaks. **CAUTION:** Do not overtighten bolts.

Instructions For Removing Oil Burner

1. Turn off power to boiler.
2. Allow boiler to cool down.
3. Remove three (3) 1/2" nuts from burner flange.
4. Close oil valve. See Figure 16 and Figure 17, page 13.
5. Disconnect oil line from burner.

Recommend replacing nozzle at start of each heating season.

Lubricate burner motor and circulator motor - if required - with few drops of good grade of light motor oil. Do not over oil.

Have qualified service agent service burner and check controls and electrodes for carbon or cracks in insulators. Adjust burners to produce conditions shown in Start-up and Adjustment of Oil Burner procedure.

Instructions For Replacing Oil Burner

1. Reconnect oil line.
2. Open oil valve. See Figure 16 and Figure 17, page 13.
3. Install and tighten three (3) 1/2" nuts on burner flange.
4. Turn on power to boiler.

SERVICE CHECKLIST

Inspect Chimney and Flue Pipe	[X]	Controls and Safety Devices	[X]
Inspect and Clean Appliance	[X]	Nozzle-Size, Angle, Type	[*]
Inspect Oil Line - Size/Leaks	[X]	Pump Pressure/Vacuum	[*]
Inspect Electrical Connections	[X]	Line Voltage/Motor Amps	[*]
Install New Filter	[X]	Smoke Test	[*]
Room Make-up Air	[X]	Draft-Overfire/In Flue	[*]
Electrode Setting	[X]	CO ₂ or O ₂	[*]
Proper Light-Off (Hot & Cold)	[X]	Flue Gas Temperature	[*]

* Measure with instruments and record results below.

SERVICE RECORD									
Date	Nozzle			Pump Pressure PSI	Smoke#	Draft		CO ₂ or O ₂	Flue Temp °F
	Size	Angle	Type			O.F.	INF		

IMPORTANT

In accordance with Section 325 (f) (3) of the Energy Policy and Conservation Act, this boiler is equipped with a feature that saves energy by reducing the boiler water temperature as the heating load decreases. This feature is equipped with an override which is provided primarily to permit the use of an external energy management system that serves the same function.

THIS OVERRIDE MUST NOT BE USED UNLESS AT LEAST ONE OF THE FOLLOWING CONDITIONS IS TRUE:

- An external energy management system is installed that reduces the boiler water temperature as the heating load decreases.
- This boiler is not used for any space heating
- This boiler is part of a modular or multiple boiler system having a total input of 300,000 BTU/hr or greater.
- This boiler is equipped with a tankless coil.



ECR International Inc. 2201 Dwyer Avenue, Utica, NY 13501
 Tel. 800 253 7900
www.ecrinternational.com

All specifications subject to change without notice.
 ©2017 ECR International, Inc.