

PCB SCU-SO2 REPLACEMENT KIT INSTRUCTIONS

Kit #550003266

FOR UCS & DMG 240/380 BOILER

Kit installation shall be completed by qualified agency.

⚠ WARNING

Fire, explosion, asphyxiation and electrical shock hazard. Improper installation could result in death or serious injury. Read this instruction and understand all requirements, including requirements of authority having jurisdiction, before beginning installation. Installation not complete until appliance operation verified per Installation, Operation & Maintenance Manual provided with boiler.

⚠ CAUTION

Laceration, burn hazard. Metal edges and parts may have sharp edges and/or may be hot. Use appropriate personal protection equipment to include safety glasses and gloves when installing or servicing this appliance. Failure to follow these instructions could result in minor or moderate injury.

Figure 1 - 240 Heat Exchanger - Front of Boiler

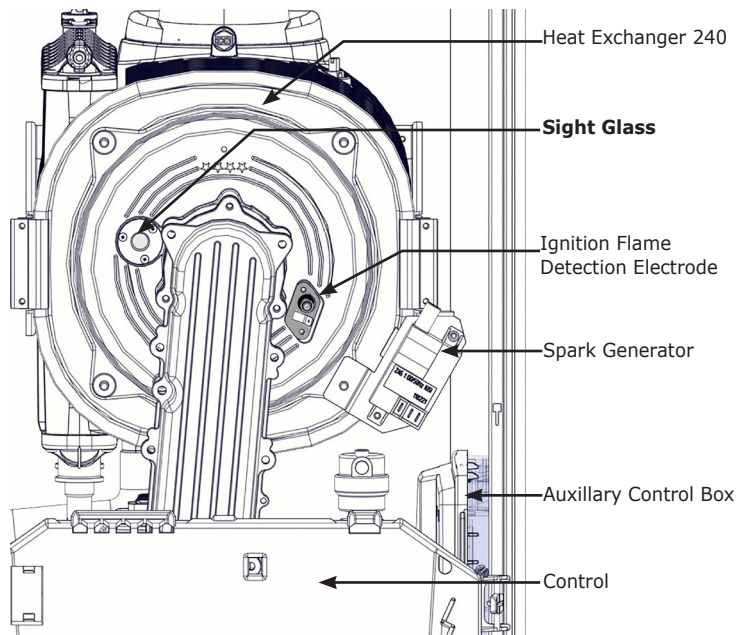

1. Follow instructions TO TURN OFF GAS TO APPLIANCE found on Operating Instructions label on boiler or in Installation, Operation & Maintenance Manual. Verify all electrical power to boiler is turned off.

⚠ WARNING

Electrical shock hazard. Turn OFF electrical power supply at service panel.

2. Turn electric and gas off to appliance.
3. Remove two (2) screws from jacket cover. Lift jacket off.

⚠ WARNING

Burn hazard. Verify unit has cooled before servicing. Use appropriate personal protection equipment.

4. Inspect combustion chamber through sight glass. Verify flame is not present. See figure 1.
5. Press tabs and place control panel in down position. See Figure 2.

Figure 2 - Control Panel and Tab

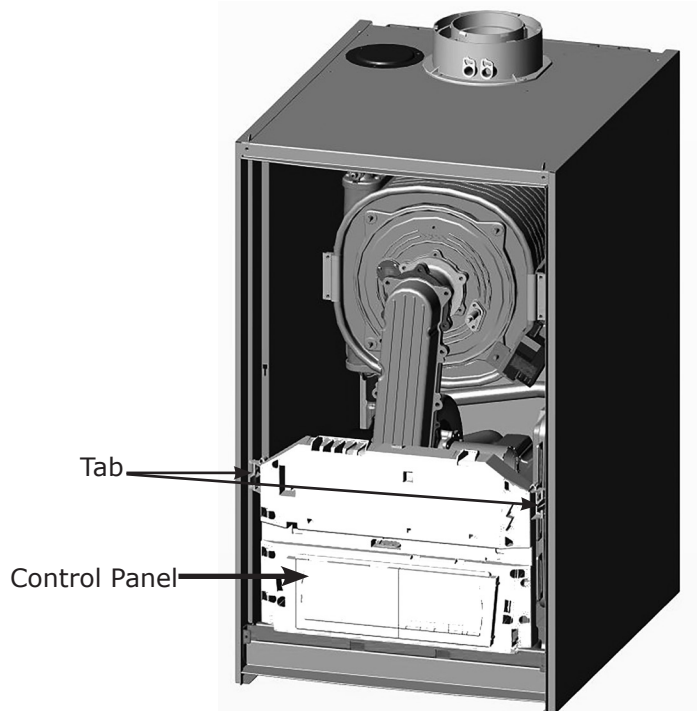

PCB SCU-S02 REPLACEMENT KIT INSTRUCTIONS

6. Remove screw in upper right corner of Auxiliary Control box. Slide Auxiliary Control box toward front of boiler. Place Auxiliary control box on top of main control box. See Figures 3 and 4.
7. Unlatch 3 clips from Auxiliary Control Box, remove cover. See Figure 4.

Note Label/note all wiring connections to PCB SCU-S02 board.

8. Remove all wiring connections to PCB SCU-S02.
9. Remove three (3) screws securing SCU-S02 to Auxiliary Control Box, remove SCU-S02.
10. Place new PCB into Auxiliary Control Box in same location and position as removed board. Secure with three (3) removed screws.
11. Connect all wiring to PCB SCU-S02 following previously made label/notes.
12. Replace Auxiliary Control Box cover, engage latches to secure.
13. Slide auxiliary control box towards back of boiler. Engage tabs on auxiliary control box with slots in right support. Secure with screw in upper right corner. See Figure 4.
14. Place Control Panel back to upright position.
15. Reattach external return piping to boiler.
16. Turn water on. Fill boiler. Purge air from system. Check for water leaks.
17. Turn power and gas on. Check for leaks.
18. Position control panel in up position. See Figure 2.
19. Resume operation using OPERATING INSTRUCTIONS found on Operating Instructions label on boiler or in Installation, Operation & Maintenance Manual.
20. Install front panel secure with screws.
21. Verify proper operation.

Figure 3 - Auxiliary Control Box

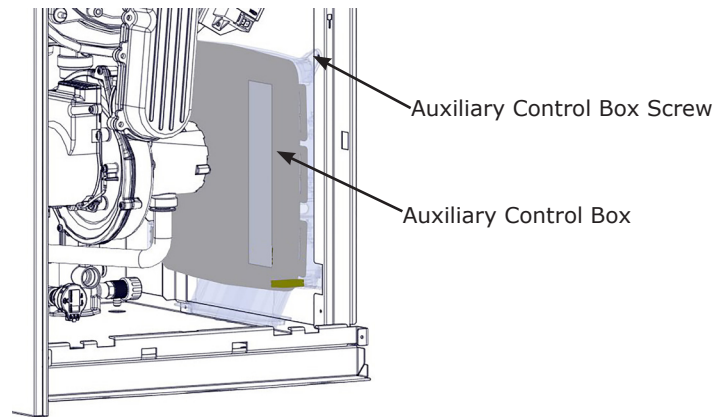
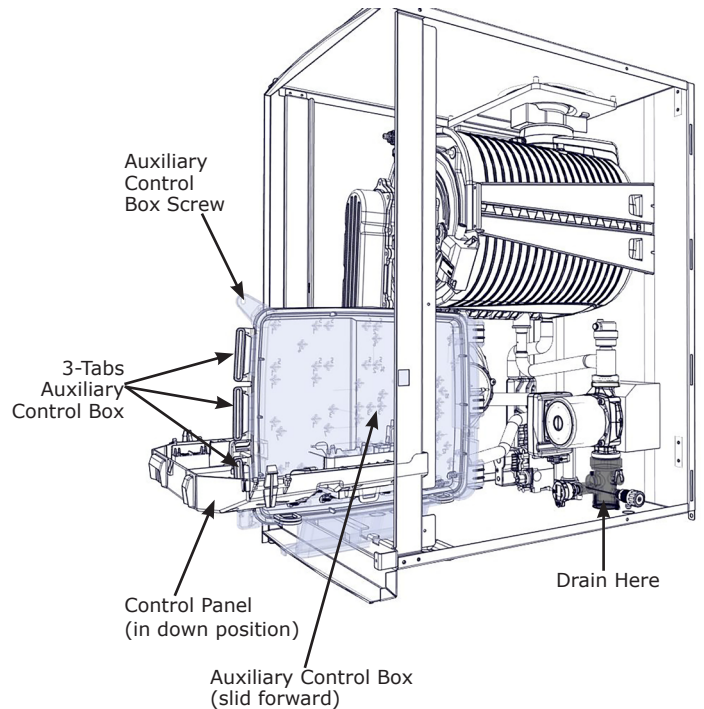

Figure 4 - Inlet Assembly



PCB SCU-S02 Replacement Kit 550003266 -Includes:

Description	PART #	Qty
PCB SCU-02	-	1
PCB SCU-02 KIT INSTRUCTIONS	240011707	1