

SAFETY PCB REPLACEMENT Kit #550003269 Instructions FOR UCS & DMG 240/380 BOILER

Kit installation shall be completed by qualified agency.

⚠ WARNING

Fire, explosion, asphyxiation and electrical shock hazard. Improper installation could result in death or serious injury. Read this instruction and understand all requirements, including requirements of authority having jurisdiction, before beginning installation. Installation not complete until appliance operation verified per Installation, Operation & Maintenance Manual provided with boiler.

⚠ CAUTION

Laceration, burn hazard. Metal edges and parts may have sharp edges and/or may be hot. Use appropriate personal protection equipment to include safety glasses and gloves when installing or servicing this appliance. Failure to follow these instructions could result in minor or moderate injury.

1. Follow instructions TO TURN OFF GAS TO APPLIANCE found on Operating Instructions label on boiler or in Installation, Operation & Maintenance Manual. Verify all electrical power to boiler is turned off.

⚠ WARNING

Electrical shock hazard. Turn OFF electrical power supply at service panel.

2. Turn electric and gas off to appliance.
3. Remove two (2) screws from jacket cover. Lift jacket off.

⚠ WARNING

Burn hazard. Verify unit has cooled before servicing. Use appropriate personal protection equipment.

4. Inspect combustion chamber through sight glass. Verify flame is not present. See figure 1.
5. Press tabs and place control panel in down position. See Figure 3.

Figure 1 - 240 Heat Exchanger - Front of Boiler

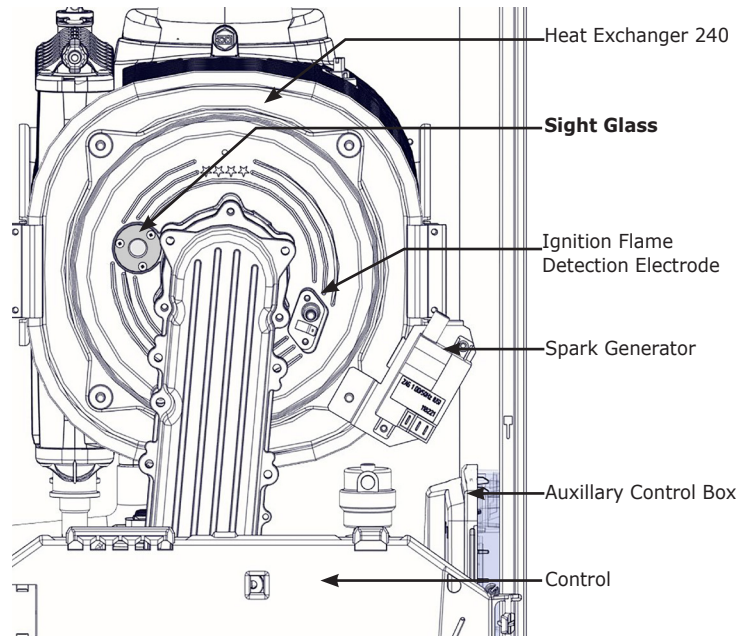
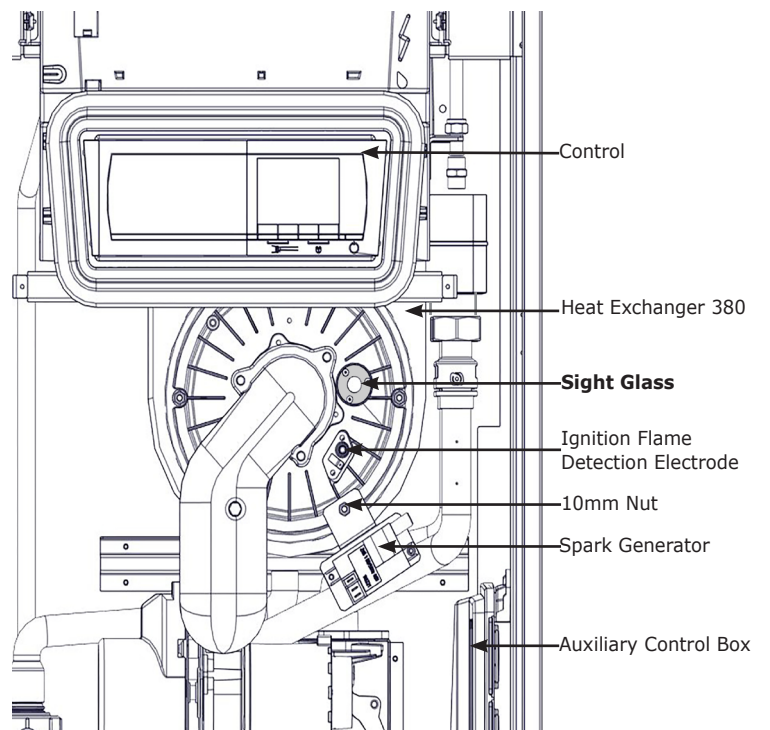

Figure 2 - 380 Heat Exchanger - Front of Boiler



SAFETY PCB REPLACEMENT KIT INSTRUCTIONS

6. Unlatch cover, raise control housing compartment cover until secured.
7. Remove safety PCB from PCU-04. PCB is in vertical position to PCU-04. Lift to remove. See Figure 4.
8. Insert new Safety PCB into PCU-04. Verify board is fully inserted.
9. Close cover on housing compartment and latch.
10. Return Control panel to upright position.
11. Install front panel secure with screws.
12. Turn electric and gas to boiler on.
13. Resume operation using OPERATING INSTRUCTIONS found on Operating Instructions label on boiler or in Installation, Operation & Maintenance Manual.
14. Verify proper operation.

Figure 3 - Control Panel and Tab -240, Up Position

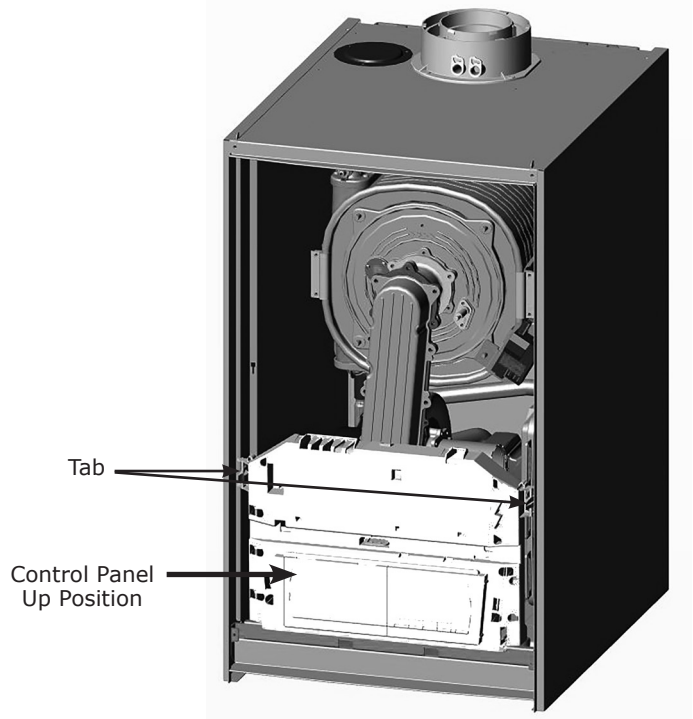
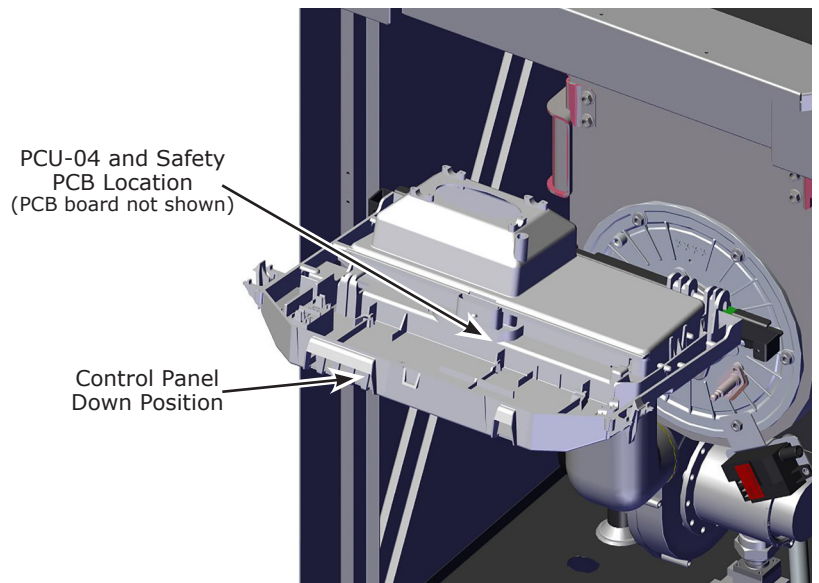

Figure 4 - Control Panel and Tab -380, Down Position



Configuration Key Kit 550003269 -Includes:		
Description	PART #	Qty
SAAFETY PCB	-	1
SAFETY PCB REPLACEMENT KIT INSTRUCTIONS	240011710	1