

CONDENSATE TRAP REPLACEMENT KIT 550003247 INSTRUCTIONS FOR UCS & DMG 380 BOILER

Kit installation shall be completed by qualified agency.

⚠ WARNING

Fire, explosion, asphyxiation and electrical shock hazard. Improper installation could result in death or serious injury. Read these instructions and understand all requirements, including requirements of authority having jurisdiction, before beginning installation. Installation not complete until appliance operation is verified per Installation, Operation & Maintenance Manual provided with boiler.

⚠ CAUTION

Laceration, burn hazard. Metal edges and parts may have sharp edges and/or may be hot. Use appropriate personal protection equipment to include safety glasses and gloves when installing or servicing this appliance. Failure to follow these instructions could result in minor or moderate injury.

Condensate Trap Kit Replacement Instructions

1. Follow instructions To TURN OFF GAS TO APPLIANCE found on Operating Instructions label on boiler or in Installation, Operation & Maintenance Manual. Verify all electrical power to boiler is turned off.

⚠ WARNING

Electrical shock hazard. Turn OFF electrical power supply at service panel.

2. Remove two (2) screws from front jacket cover. Lift jacket off.

⚠ WARNING

Burn hazard. Verify unit has cooled before servicing. Use appropriate personal protection equipment.

3. Inspect combustion chamber through sight glass. Verify flame is not present. See Figure 1.
4. Remove two (2) screws securing condensate collector plug from bottom of trap. See Figure 2.
5. Disconnect field piping from units discharge pipe.
6. Remove two (2) screws securing support bracket to back of unit. See Figure 2.
7. Lift up on condensate trap and pull through bottom panel.
8. Remove clamps from top of condensate trap. Disconnect tubing.

Figure 1 - Sight Glass

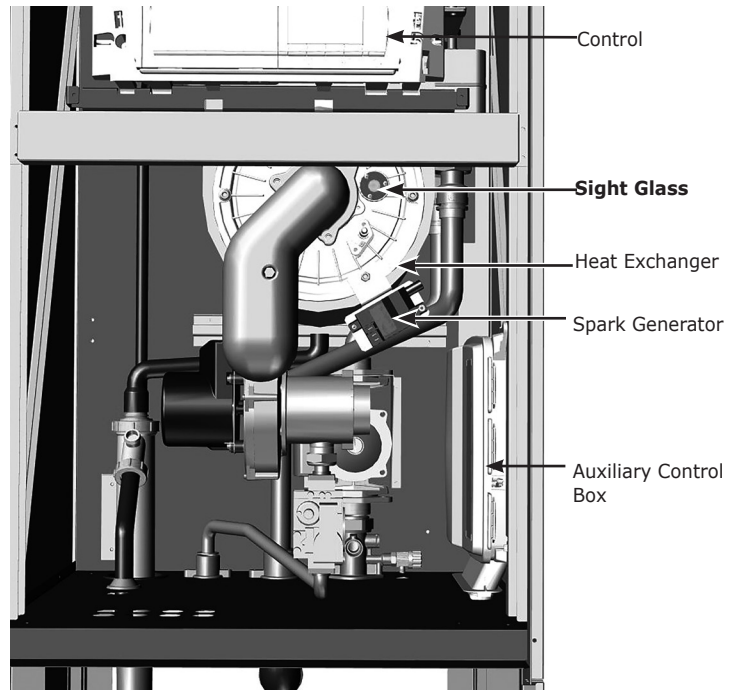
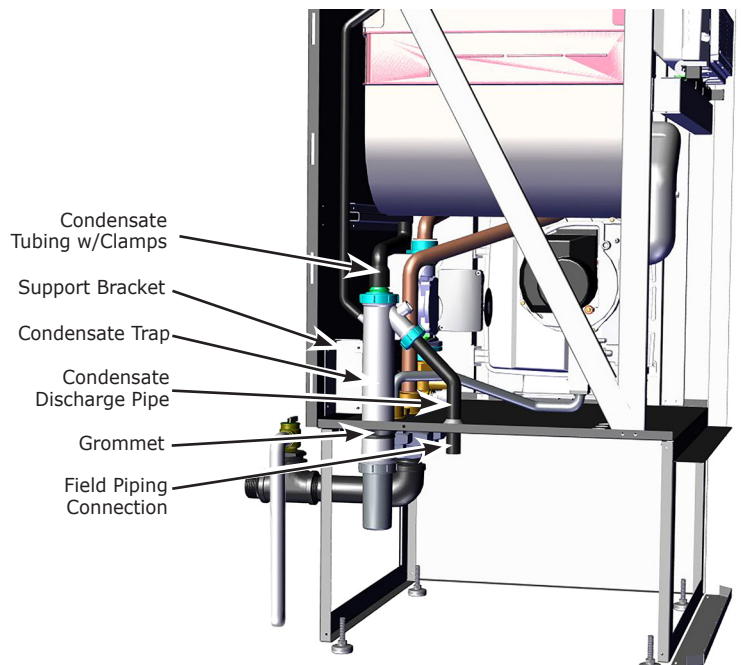

Figure 2 - Condensate Trap - (Left and front panels removed for illustration only)



Illustrations are a depiction of the boiler for general location of parts and are subject to change without notice.

CONDENSATE TRAP REPLACEMENT FOR UCS & DMG 380 BOILER

9. Remove two (2) screws securing condensate trap to bracket.
10. Secure new condensate trap to bracket with two (2) screws.
11. Install new discharge pipe on new trap.
12. Reconnect condensate tubing to trap inlet.
13. Reinsert trap through syphon gasket and grommets.
14. Secure support bracket with two (2) removed screws to back panel.

WARNING

Asphyxiation hazard! Fill condensate trap before starting boiler to avoid combustion products escaping boiler. Failure to follow these instructions could result in death or serious injury.

16. Prime new condensate trap by adding 1 cup water. Pour water into exhaust vent or top of condensate trap until water begins to flow through siphon. Visually inspect siphon to ensure it is full with clean water.
17. Turn Gas on. Check for leaks
18. Resume operation using OPERATING INSTRUCTIONS found on Operating Instructions label on boiler or in Installation, Operation & Maintenance Manual.
19. During operation check condensate trap to ensure it is draining properly.
20. Install front panel. Secure in place with removed screws.
21. Verify proper operation

PARTS LIST

UCS, DMG - 380 Condensate Trap Replacement Kit 550003279 includes:		
DESCRIPTION	PART #	QTY
2 Way Syphon	-	1
Gasket Plug	-	1
Discharge Pipe Syphon	-	1
Grommet	-	1
Syphon Gasket	-	1
Instructions	240011716	1