

AIR/GAS VENTURI REPLACEMENT KIT 550003292 INSTRUCTIONS FOR UCS & DMG 380 BOILER

Kit installation shall be completed by qualified agency.

⚠ WARNING

Fire, explosion, asphyxiation and electrical shock hazard. Improper installation could result in death or serious injury. Read this instruction and understand all requirements, including requirements of authority having jurisdiction, before beginning installation. Installation not complete until appliance operation verified per Installation, Operation & Maintenance Manual provided with boiler.

KIT 550003292 - AIR/GAS VENTURI REPLACEMENT

Description	PART #	Qty
AIR/GAS VENTURI	-	1
VENTURI GASKET	-	1
O-RING 70x3		1
KIT INSTRUCTIONS	240011731	1

⚠ CAUTION

Laceration, burn hazard. Metal edges and parts may have sharp edges and/or may be hot. Use appropriate personal protection equipment to include safety glasses and gloves when installing or servicing this appliance. Failure to follow these instructions could result in minor or moderate injury.

1. Follow instructions TO TURN OFF GAS TO APPLIANCE found on Operating Instructions label on boiler or in Installation, Operation & Maintenance Manual. Verify all electrical power to boiler is turned off.

⚠ WARNING

Electrical shock hazard. Turn OFF electrical power supply at service panel.

2. Turn power and gas off to appliance.
3. Remove two (2) screws from front panel. Lift panel off.

⚠ WARNING

Burn hazard. Verify unit has cooled before servicing. Use appropriate personal protection equipment.

4. Inspect combustion chamber through sight glass. Verify flame is not present. See Figure 1.

Figure 1 - Sight Glass - Front of Boiler

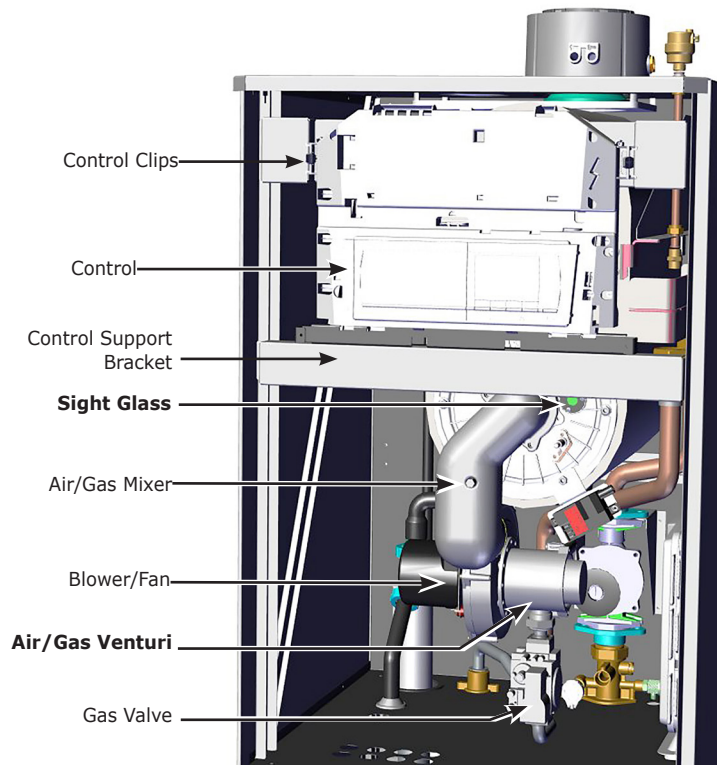

AIR/GAS VENTURI REPLACEMENT KIT INSTRUCTIONS

5. Disconnect nut from gas valve to Air/Gas Venturi, remove gasket. See Figure 2.
6. Remove three (3) screws securing the Air/Gas Venturi flange to Blower/Fan, remove o-ring.
7. Secure with three (3) screws new Air/Gas Venturi with new o-ring to Blower/Fan.
8. Reconnect gas valve to Air/Gas Venturi with new gasket, tighten nut.
9. Turn power and gas on.
10. Check for leaks.
11. Adjust **Parameters 17-19** as indicated below A-D:

Figure 2 - Air/Gas Venturi (Front of Boiler front panel removed)

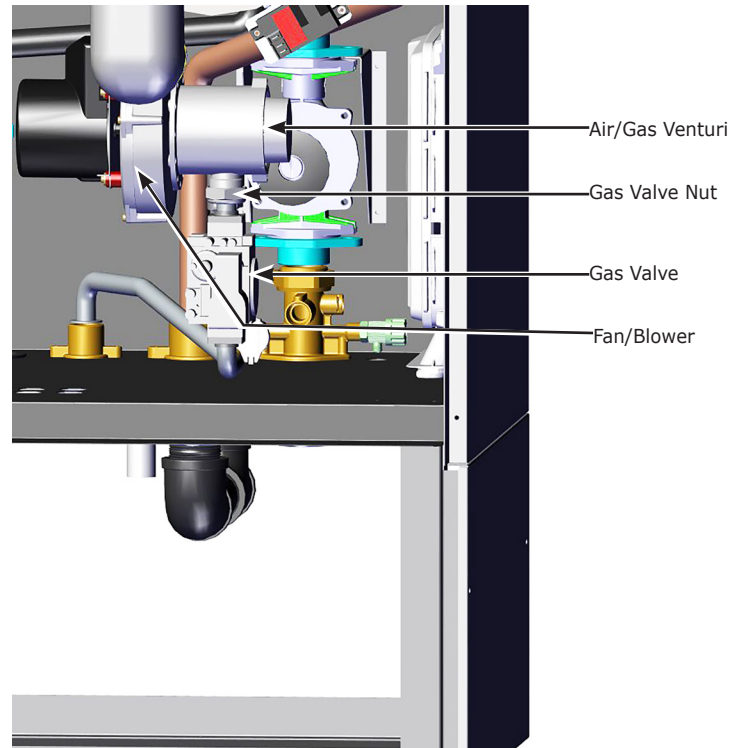
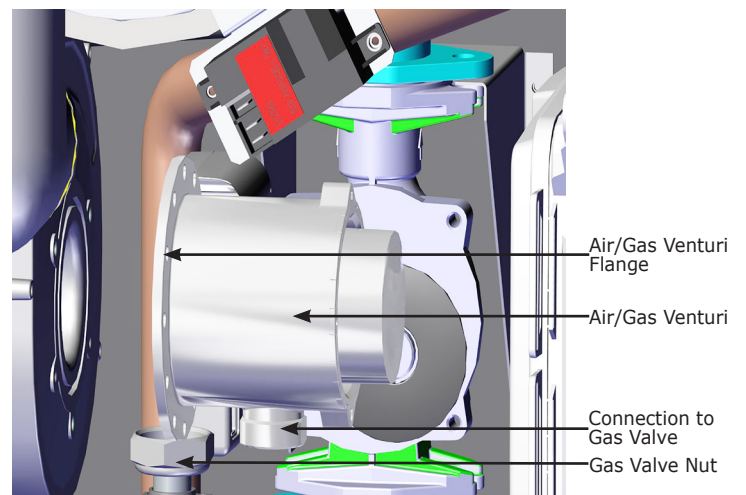

Figure 3 - Air/Gas Venturi - Removed (Front of Boiler front panel removed)



AIR/GAS VENTURI REPLACEMENT KIT INSTRUCTIONS

A - Installer Level Parameters

Parameters **P17** to **dF** (error code history) must only be modified by a qualified installer.

To prevent unwanted settings, some parameter settings can only be changed after special access code **0012** is entered.







- Press the two Menu buttons  simultaneously and then (+) button until the symbol  flashes on the menu bar.
- Select the INSTALLER menu using the  button. "CODE" appears on the display.
- Use (-) or (+) button to input the installer code "0012".
- Confirm using  button, "P1" is displayed with "1" flashing.
- Press  button a second time, the value will appear and flashes, for example [80°C (176°F)].
- Change the value by pressing the [-] or [+] button. [In this example using [-] button to change the value to 60 °C (140 °F).]
- Confirm the value with the  button, "P1" is displayed with 1 flashing. Button, "P1" is displayed with 1 flashing. If necessary, set other parameters by selecting them using the (-) or (+) button.
- Press  button 2 times to return to current operating mode.

FIGURE 5 - Installer Level Parameters



Natural Gas				Propane			
Venturi		Nozzle		Venturi		Nozzle	
in	mm	in	mm	in	mm	in	mm
1 3/16	30	7/32	5.3	1.18	30	5/32	4

B - Boiler has two dedicated built in test ports. See Figure 6.

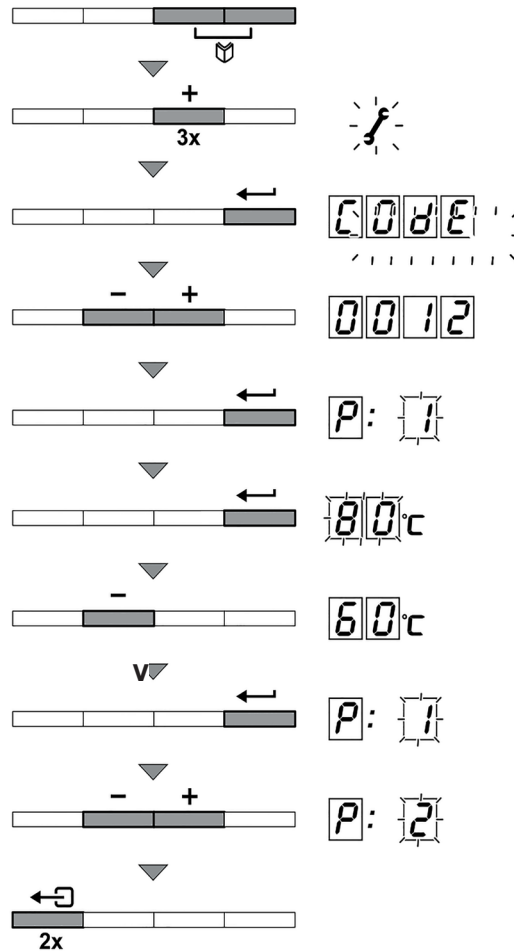
One connection port is connected to exhaust flue (**A**), and allows monitoring of the quality of combustion products and combustion efficiency.

Other is connected to combustion air intake (**B**), used to check for recycling products for combustion.

The following can be measured at exhaust flue test port:

- temperature of combustion products
- oxygen (O₂) or carbon dioxide (CO₂) concentration;
- carbon monoxide (CO) concentration.

Temperature of combustion air must be measured on air intake test port (**B**) by inserting measurement sensor approximately 3-3/16" (80.00 mm) (**C**).

FIGURE 6 - Combustion Air Sample Ports

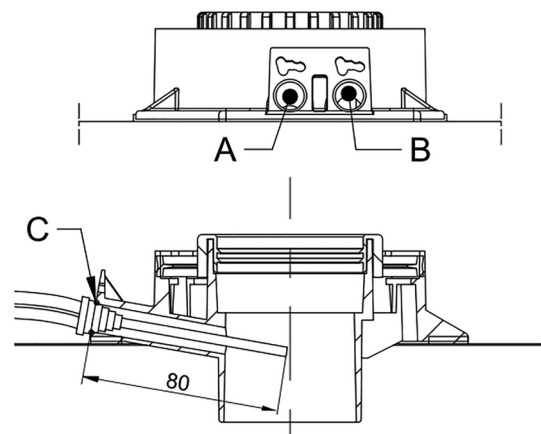

AIR/GAS VENTURI REPLACEMENT KIT INSTRUCTIONS

C - Combustion Setup (High-Fire)

- Unscrew exhaust port plug at exhaust flue test port. See Figure 6.
- Insert combustion analyzer into exhaust flue test port. Verify opening around combustion analyzer probe is completely sealed when taking measurements.
- Set boiler to high-fire by pressing two buttons simultaneously. Display will show **H3** and the  symbol will appear.
- Measure percentage of O₂ or CO₂ in flue gases.
- Compare the measured values with values in table below. Remove front panel when comparing values.
- Adjust gas/air ratio using high-fire adjustment screw (**V**) if needed. Turn screw clockwise to reduce CO₂ level and counterclockwise to increase it.

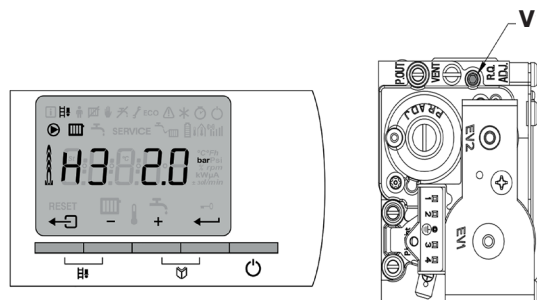

O ₂ /CO ₂ Values at High Fire Natural Gas			
Nominal value		Permitted value	
O ₂ %	CO ₂ %	O ₂ %	CO ₂ %
4.3	9.3	3.9 - 4.7	9.1 - 9.5

O ₂ /CO ₂ Values at High-Fire Propane Gas			
Nominal value		Permitted value	
O ₂ %	CO ₂ %	O ₂ %	CO ₂ %
5.7	10.0	5.4 - 6.0	9.8 - 10.2

D - Combustion Setup (Low-Fire)

- Unscrew exhaust port plug at exhaust flue test port.
- Insert combustion analyzer into exhaust flue test port. Verify the opening around combustion analyzer probe is completely sealed when taking measurements.
- Set boiler to low-fire by pressing two buttons simultaneously. If the boiler is already in combustion setup mode for high fire, press the (-) button several time until **L3** is displayed on the screen.
- Measure percentage of O₂ or CO₂ in flue gases.
- Compare the measured values with values in table below. Remove front panel when comparing values.
- Adjust gas/air ratio using low-fire adjustment screw (**K**) if needed. Turn screw clockwise to increase CO₂ level and counterclockwise to decrease it.

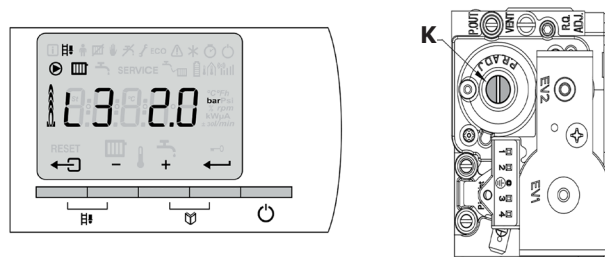

K - Screw cover shown. Adjustment screw is located under cover.

O ₂ /CO ₂ Values at Low-Fire Natural Gas			
Nominal value		Permitted value	
O ₂ %	CO ₂ %	O ₂ %	CO ₂ %
5.7	8.5	5.4 - 6.1	8.3 - 8.7

O ₂ /CO ₂ Values at Low-Fire Propane Gas			
Nominal value		Permitted value	
O ₂ %	CO ₂ %	O ₂ %	CO ₂ %
6.4	9.6	6.1 - 6.70	9.4 - 9.8

12. Follow instructions in boiler's Installation, Operation & Maintenance Manual for proper startup and verification procedures.

13. Verify proper operation.