

CONDENSATE PIPE REPLACEMENT KIT INSTRUCTIONS

Kit #550003289

FOR UCS & DMG 380 BOILER

Kit installation shall be completed by qualified agency.

⚠️ WARNING

Fire, explosion, asphyxiation and electrical shock hazard. Improper installation could result in death or serious injury. Read this instruction and understand all requirements, including requirements of authority having jurisdiction, before beginning installation. Installation not complete until appliance operation verified per Installation, Operation & Maintenance Manual provided with boiler.

⚠️ CAUTION

Laceration, burn hazard. Metal edges and parts may have sharp edges and/or may be hot. Use appropriate personal protection equipment to include safety glasses and gloves when installing or servicing this appliance. Failure to follow these instructions could result in minor or moderate injury.

⚠️ WARNING

Asphyxiation hazard! Fill condensate trap before starting boiler to avoid combustion products escaping boiler. Failure to follow these instructions could result in death or serious injury.

1. Follow instructions TO TURN OFF GAS TO APPLIANCE found on Operating Instructions label on boiler or in Installation, Operation & Maintenance Manual. Verify all electrical power to boiler is turned off.

⚠️ WARNING

Electrical shock hazard. Turn OFF electrical power supply at service panel.

2. Turn power and gas off to appliance.
3. Remove two (2) screws from front panel. Remove panel

⚠️ WARNING

Burn hazard. Verify unit has cooled before servicing. Use appropriate personal protection equipment.

4. Inspect combustion chamber through sight glass. Verify flame is not present. See Figure 1.
5. Loosen clamps from condensate collection tray and heat exchanger. See Figure 2.
6. Loosen clamps from top of condensate trap. Remove pipes.

⚠️ WARNING

Asphyxiation hazard! Fill condensate trap before starting boiler to avoid combustion products escaping boiler. Failure to follow these instructions could result in death or serious injury.

Condensate Pipe Replacement Kit 550003289 - Includes:

Description	PART #	Qty
CONDENSATE PIPE TO CONDENSATE TRAY	-	1
CONDENSATE PIPE TO HEAT EXCHANGER	-	1
INSTRUCTIONS	240011734	1

Figure 1 - 380 - Sight Glass Location

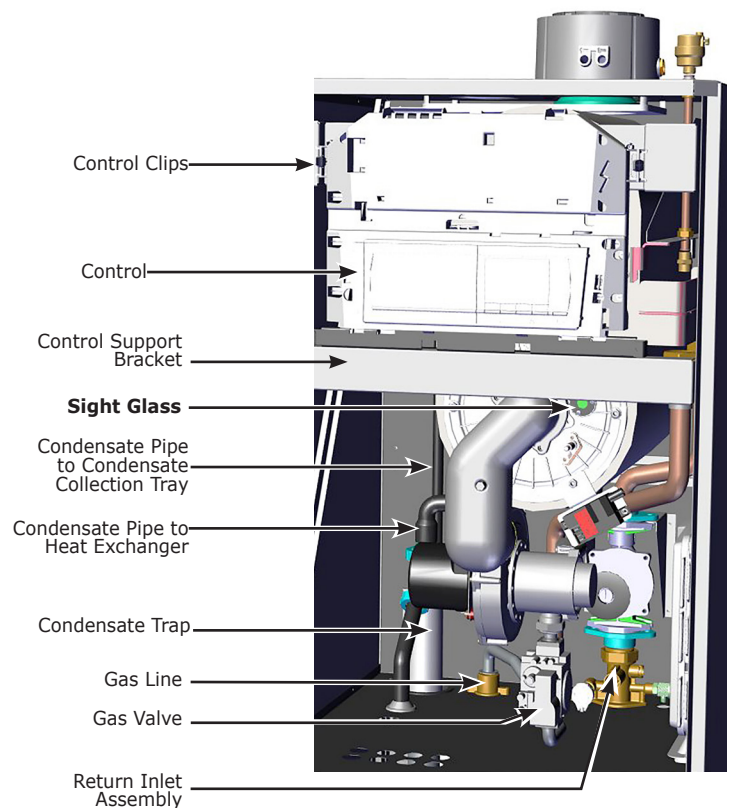

CONDENSATE PIPE REPLACEMENT KIT INSTRUCTIONS

7. Prime new condensate trap by adding 1 cup water. Pour water into exhaust vent or top of condensate trap until water begins to flow through siphon. Visually inspect siphon to ensure it is full with clean water.
8. Install new condensate pipes to condensate trap. Secure pipes with clamps.
9. Connect new condensate pipe to collection tray and heat exchanger. Secure pipes with clamps.
10. Turn power and gas on. Check for leaks.
11. Resume operation using OPERATING INSTRUCTIONS found on Operating Instructions label on boiler or in Installation, Operation & Maintenance Manual.
12. Install front panel secure with screws.
13. Verify proper operation.

Figure 2 - Condensate Piping Connections (View Front of Boiler Front Panel Removed)

