



Direct Vent Supplement

LRF / LRFV Oil Fired Warm Air Furnaces

INSTALLATION, OPERATION & MAINTENANCE MANUAL

WARNING

Fire, explosion, asphyxiation and electrical shock hazard. Improper installation could result in death or serious injury. Read this manual and understand all requirements before beginning installation.

NOTICE

Information contained in this manual pertains to oil fired direct vent furnaces equipped with manufacturer provided and field installed blocked vent safety control system (pressure switch).

ALL INSTALLATIONS MUST MEET ALL LOCAL, PROVINCIAL/
STATE, AND FEDERAL CODES WHICH MAY DIFFER FROM THIS
MANUAL



Manufactured by:
ECR International Inc.
2201 Dwyer Avenue, Utica, NY 13501
Tel. 800 253 7900
www.ecrinternational.com
PN 240011896 REV. C [03/15/2018]



ALL INSTALLATIONS MUST MEET ALL LOCAL, PROVINCIAL/STATE,
AND FEDERAL CODES WHICH MAY DIFFER FROM THIS MANUAL

Read and understand this manual before beginning
installation. Instructions must be kept with furnace
for future reference.



ECR international
EST. 1928
A Family of Heating & Cooling Brands.

DIRECT VENT OIL FIRED WARM AIR FURNACE

1. DIRECT VENTING OF OLSEN OIL FIRED FURNACES	4
2. VENT TERMINAL LOCATION	4
3. VENT TERMINAL INSTALLATION	6
4. VENT TERMINAL RISER KIT	6
5. DIRECT VENT INTAKE AIR PIPE INSTALLATION	7
6. VENTING INSTALLATION - DIRECT VENT	8
7. BLOCKED VENT SAFETY SWITCH PRESSURE TUBING CONNECTIONS.	8
8. OIL BURNER SETUP.....	8
9. FURNACE SET UP ADJUSTMENTS	11
10. BLOCKED VENT SAFETY SHUT OFF SYSTEM	11
11. SEQUENCE OF OPERATION	11
12. FINAL CHECK OUT.....	11
DIRECT VENTING WIRING DIAGRAM	12
DIRECT VENTING OF OLSEN OIL FIRED FURNACES - VENTING COMPONENTS.....	13
VENTING COMPONENTS/MATCHING GUIDE	14
DIRECT VENT - PARTS IDENTIFICATION	14
BECKETT BURNER BLOCKED VENT SAFETY (BVS) OPERATION	15
BECKETT BURNER TROUBLESHOOTING	16
RIELLO 40BF BLOCKED VENT SAFETY (BVS) OPERATION	17
RIELLO 40BF BURNER TROUBLESHOOTING	18
HOMEOWNER'S REFERENCE TABLE	19

WARNINGS AND SAFETY SYMBOLS

DANGER

Indicates a hazardous situation which, if not avoided, **WILL** result in death or serious injury

CAUTION

Indicates a hazardous situation which, if not avoided, could result in minor or moderate injury.

WARNING

Indicates a hazardous situation which, if not avoided, could result in death or serious injury.

NOTICE

Used to address practices not related to personal injury.

1. DIRECT VENTING OF OLSEN OIL FIRED FURNACES

- Installation shall be done by a "Qualified Installer".
"Qualified Installer" shall mean an individual who has been properly trained or is a licensed installer.
- LRF oil fired furnaces with suffixes NXU for Beckett's NX , and RBU for Riello's 40BF series oil burners, are certified for venting through the wall using ducted outdoor air for combustion.
- Direct Vent series is ideal for applications where conventional chimney is unavailable, nor easily installed; an electrically heated home being retrofit for oil forced air heating for example.
- The term Direct Vent refers to a sealed combustion system.
- Direct vented appliances require some foresight and planning, since the range of flue lengths is restricted, clearances are critical, and national and local codes are quite strict with respect to safety. Be sure the furnace can be installed within physical limitations of the home, and in accordance with local codes and regulations.
- Physical limitations include practical issues such as sufficient clearance to grade. It is advisable to install the vent termination in an area sheltered from winter prevailing winds. Avoid vent termination locations subject to frequent strong wind gusts.
- It is installer's responsibility upon installation and user's responsibility during subsequent operation to ensure gases issuing from the vent terminal do not cause a hazard through contact with adjacent naturally occurring combustible materials.
- It is homeowner's responsibility to ensure the area around the vent terminal and air intake is free of snow, ice and debris. Check the vent terminal during heavy snowstorms to ensure proper operation.
- In extremely cold climates, ice may have to be removed from the vent terminal on a regular basis.
- B-VENT SHALL NOT BE USED IN THE VENT SYSTEM.

Oil Burners:

Beckett NX
Riello 40BF

Venting Materials and Fittings:

For approved components, see Figures 9-11.

2. VENT TERMINAL LOCATION

Figure 1 - Standard Vent Terminal Assembly

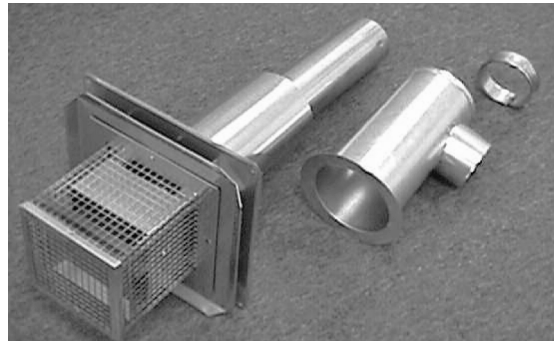

DIRECT VENTING OF OLSEN OIL FIRED FURNACES

Through the wall termination shall be installed in accordance with latest editions of CAN/CSA B-139 (Canada), NFPA-31 (United States), and / or any applicable local codes.

Vent terminal can be installed in a wall having minimum thickness of 5" and maximum thickness of 10".

Refer to Figure 2 below. In Canada, vent terminal shall not terminate:

- A. Directly above a paved sidewalk or paved driveway located between two buildings, and serves both of them.
- B. Less than 7 feet (2.13 m) above any paved sidewalk or a paved driveway.
- C. Within 6 feet (1.80 m) of a window, door, or mechanical air supply inlet to any building, including soffit openings.
- D. Above gas / regulator assembly within 3 feet (1 m) horizontally of center-line of regulator.
- E. Within 6 feet (1.80 m) of any gas service regulator vent outlet or within 3 feet (1 m) of any oil tank vent or any oil tank fill inlet.
- F. Less than 1 foot (0.3 m) above grade level within 6 feet (1.80 m) of any combustion air inlet, unless appliance is otherwise certified.
- G. Within 6 feet (1.80 m) of the property line.
- H. Underneath a verandah, porch, or deck.

- I. So flue gases are directed at combustible material or at any openings of surrounding buildings that are within 6 feet (1.80 m).
- J. Less than 3 feet (1 m) from an inside corner of an L-shaped structure.
- K. So that the bottom of the vent termination opening is less than 1 foot (0.3 m) above any surface that may support snow, ice, or debris.
- L. So that the flue gases are directed towards bricks, siding, or other construction, in such a manner that may cause damage from heat or condensate from the flue gas.
- M. Within 4 feet (1.2 m) of a power venter.

Figure 2 - Vent Terminal Locations - Canada

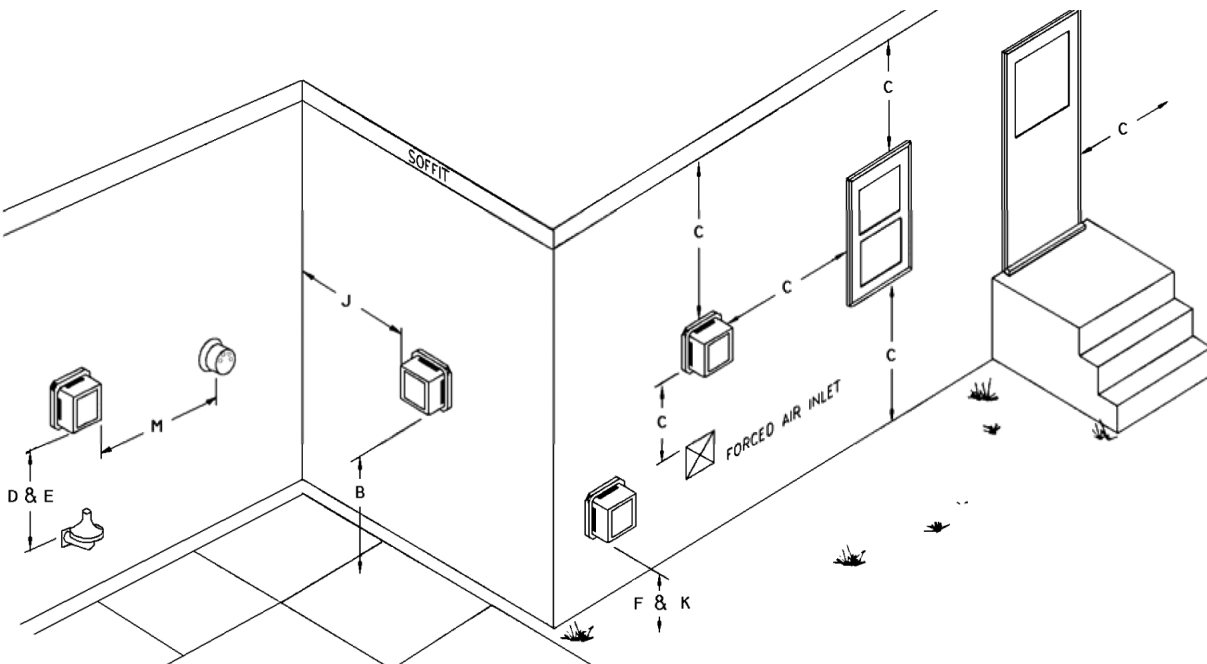

Refer to Figure 3 below. In the United States, a vent terminal shall not terminate:

- Less than 7 feet (2.13 m) above any adjacent public walkway.
- Less than 4 feet (1.22 m) below, 4 feet horizontally, or 1 foot (0.3 m) above a door, window, or gravity air inlet of the structure.
- Less than 1 foot (0.3 m) above grade.
- Less than 1 foot (0.3 m) from the soffit of the roof of the structure.
- Less than 3 feet (0.9 m) from the inside corner of an L shaped structure.
- Less than 5 feet (1.6 m) from a gas regulator vent outlet, or oil tank vent outlet.

3. VENT TERMINAL INSTALLATION

This applies to the standard 28972 Direct Vent Oil Vent Terminal. See Figure 1. Select the location of wall penetration that conforms to the code for exterior location, as close to the appliance as possible, maintains clearance to combustibles and where the minimum 1/4-inch per foot slope back to the appliance can be maintained.

- Cut 6-1/2" diameter hole through the wall.
- Remove the Intake Air Sleeve from the Terminal.
- Insert Terminal through the wall from outside, secure with 4 screws to the wall, seal to wall with weatherproof sealant.
- From inside the building, reattach the Intake Air Sleeve and secure inner sleeve to outer sleeve with 2 screws. Use 4 screws to secure Sleeve to the wall. Ensure the Intake Air Connector is located for ease of attachment and complies with code.

4. VENT TERMINAL RISER KIT

The 29231 Vent Terminal Riser Kit has been designed to increase the height above grade level of the Vent Terminal by approximately 3 feet. See Figure 5 for typical Vent Riser setup. This is ideal where excessive snow build up could occur or where more flexibility is required to maintain minimum clearances to grade.

Figure 3 - Vent Terminal Locations - United States

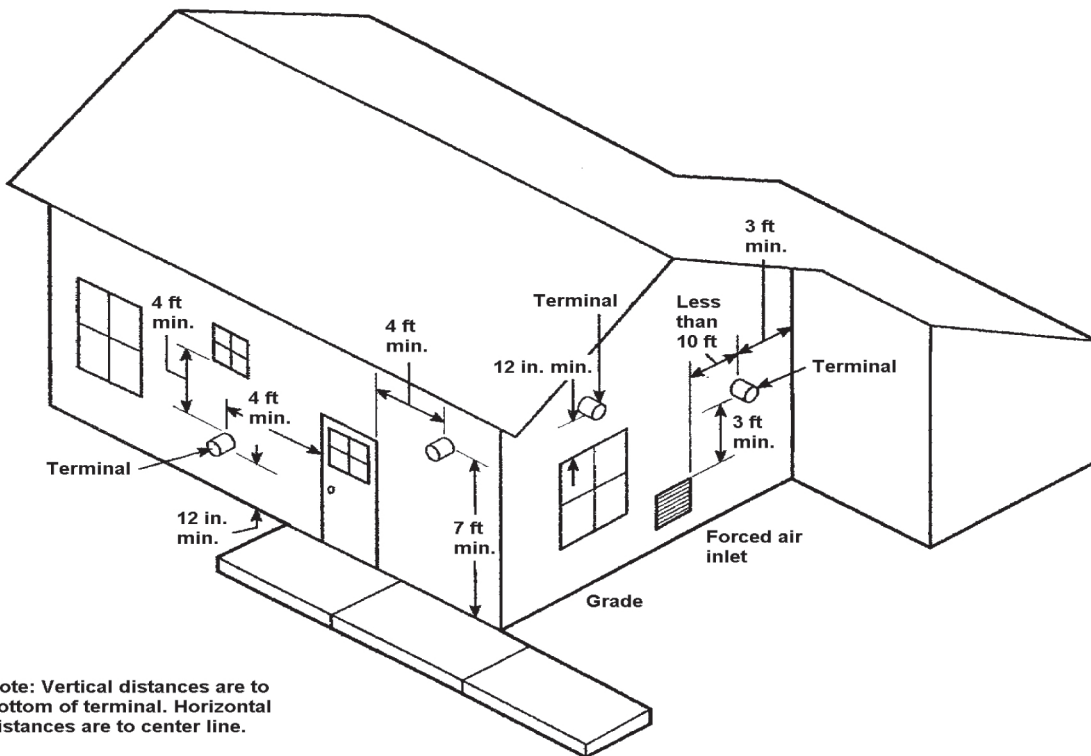

Figure 4 - Inside View of Vent Terminal



Condensation may become a problem during some climatic conditions. It may be necessary to wrap a portion, or entire intake piping (particularly metal intake piping) with waterproof insulation material.

5. DIRECT VENT INTAKE AIR PIPE INSTALLATION

NOTICE

Flexible duct for combustion air use is not permitted.

IMPORTANT: OUTDOOR AIR FOR COMBUSTION MUST BE USED.

The oil burners approved for use with ducted outdoor air for combustion are Beckett NX , Riello 40BF. All units obtain outdoor air by the following means:

Acceptable combustion air intake materials:

1. 4-inch "C" Vent (single wall galvanized).
2. 4-inch Rigid Aluminum pipe (0.030" wall thickness).
3. Beckett NX burners, are furnished with a 4" diameter straight combustion air intake collar for connecting field supplied 4" combustion air intake pipe to the burner. The intake collar is equipped with a hose fitting for connecting the negative pressure side of the blocked vent safety switch (pressure switch).
4. Riello 40BF3/BF5 burners are furnished with a 3" diameter straight combustion air intake collar (used for LRF furnaces), and a 3" diameter 90° elbow combustion air intake collar (Not used with LRF furnaces, used with other furnace models). The intake collar is equipped with a hose fitting for connecting the negative pressure side of the blocked vent safety switch (pressure switch). Riello burners are also furnished with a 3" elbow and 3" to 4" increaser fitting which connects to the intake collar for connecting field supplied 4" combustion air intake pipe to the burner.

IMPORTANT: Intake pipe and fittings should be sealed with foil tape, duct tape, or silicone caulking and attached mechanically with screws.

Maximum combustion air intake length is 25 feet using 8 90° elbows. Venting installation dictates the length from termination cannot be further than 20 feet; therefore any longer piping for combustion air intake would be unnecessary. Combustion air intake does not have minimum length.

Figure 5 - Vent Riser

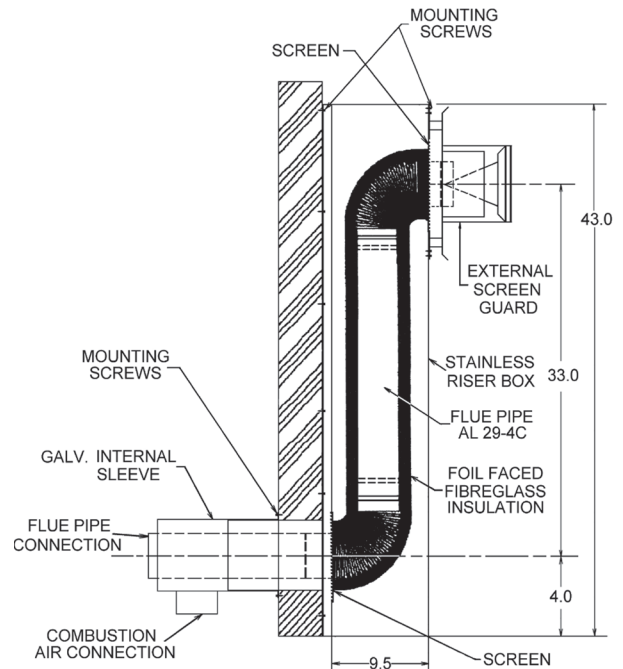

**6. VENTING INSTALLATION - DIRECT VENT
VENT CLEARANCE TO COMBUSTIBLES: ONE (1) INCH.**

⚠ WARNING

Fire, asphyxiation hazard. Do not enclose vent. Do not route vent through walls, floors or ceilings. Improper installation could result in death or serious injury.

INSTALLATION OF "INSULATED DOUBLE WALL FLEXIBLE VENT".

The inner pipe is constructed of 4 inch 316 stainless steel, with a two-ply aluminum outer pipe. High temperature insulation separates the inner and outer flex pipes. Refer to Figure 9.

IMPORTANT: The venting and vent terminal are dedicated to the furnace only; do not attempt to vent any other appliance through it.

Install venting as follows. Installation shall comply with CAN/CSA B139 Installation Code for Oil Burning Equipment (Canada) or NFPA 31 Standard for Installation of Oil Burning Equipment (United States), and / or with local codes and regulations.

- A. In as short and straight a run as possible without any unnecessary bends.
- B. There should not be any dips or sags throughout the full length of vent.
- C. Connector or vent should be sloped upwards from the appliance at least 1/4" per foot.
- D. Do not bend the connector or vent more than 90 degrees.
- E. Vent may be cut to minimum of 5 feet in length using fine tooth (24 teeth per inch) hacksaw blade.
- F. Male and female ends of appliance adapters and connectors must be cleaned with residue free brake cleaner solvent.
- G. Apply minimum 1/4" bead of Si-Ultra Copper Sealant provided, onto outside of male end of vent to appliance connector. Fit connector to vent by threading it counter-clockwise until it stops. Ensure joint is not cross-threaded.
- H. Apply minimum 1/4" bead of same sealant as mentioned above onto female end inside of appliance connector. Slip connector over end of furnace flue collar until it stops. Orient combustion sample test port in an accessible position. Tighten attached gear clamp.
- I. Support Vent every 36" to prevent sagging.
- J. Attach Terminal Connector as described in steps G and H listed above.
- K. Maximum vent length is 20 feet (using a 20 foot vent kit) Piecing vent kits together (i.e. using 2 ten foot kits is strictly prohibited).

CAUTION

Use appropriate safety precautions! Wear protective gloves. Thin metal edges are extremely sharp if not avoided, could result in minor or moderate injury.

7. BLOCKED VENT SAFETY SWITCH AND PRESSURE TUBING CONNECTIONS

⚠ WARNING

Failure to properly install the blocked vent safety switch could result in death or serious injury.

The blocked vent safety switch and associated pressure switch tubing are shipped with the burner. The pressure switch must be installed and tubing and electrical connections must be made as follows:

- Confirm correct pressure switch is provided:
 - Reillo Burners use P/N 240011861, 0.42" W.C. set point.
 - Beckett Burners use P/N 240011862, 0.65" W. C. set point.
- Install the pressure switch in correct location inside burner compartment, on control panel located above the fan timer control, using two #8 x 1/2" sheet metal screws provided with the switch. See Figure 6.
- Connect the black high temperature tubing from the positive pressure port (the black port) on the pressure switch to the hose barb on the furnace cleanout cover. The tubing should be just long enough to be installed with no dips or sags. It should be uphill all the way to the pressure switch. This prevents condensation from collecting in the tubing.
- Connect the grey pressure switch tubing from negative pressure port (the grey port) on pressure switch to the hose fitting on burner combustion air intake pipe. This tubing can be cut shorter if desired for convenience. It is not necessary to avoid dips or sags with this tubing.
- Connect the two unused yellow low voltage wires in the furnace control harness to the pressure switch terminals.

Figure 6 - Pressure Switch and Connections

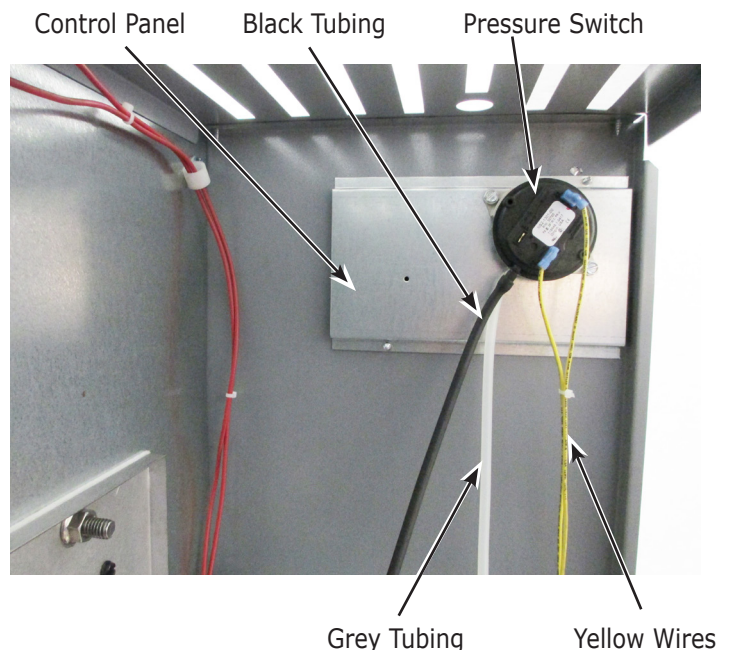

8. OIL BURNER SET UP

- Shut off electrical power to the furnace.
- Install an oil pressure gauge to the pressure port on the oil pump.
- Set up the burner for initial firing as indicated in:
 - Chart 1 for Beckett NX burners
 - Chart 2 for Riello 40BF burners
- Refer to oil burner instructions provided with furnace documents envelope for specific information concerning burner adjustment, operation and troubleshooting.
- See Figure 7 or 8 as applicable for proper air adjustment technique.
- Restore electrical power to furnace.
- Start the furnace and bleed all air from fuel oil lines.
- Close purge valve and fire the unit.
- Allow furnace to warm up to normal operating temperatures. During this time set the pump pressure in accordance with Chart 1 or 2 as applicable.
- Combustion must be checked with intake air piping connected for 100% outdoor combustion air to burner. Length of intake air piping and outside air temperature will affect the combustion readings.
 - For Riello burners the standard burner cover must be in place on the burner to insure 100% outdoor air.
- Determine the Desired CO2 Setpoint:
 - Combustion air temperature variations will affect how much air enters the burner. Colder air is denser, so contains more air per unit volume. More air enters the burner when the combustion air is cold. Combustion air temperature must be taken into consideration when setting up the burner to account for these variations.
 - When the furnace has reached steady state (after approximately 10-15 minutes), remove the bolt from the test port in the appliance connector. Set the combustion air to obtain a TRACE of smoke.
 - Using suitable combustion test instruments, measure the Trace Point CO2 at the test port.
 - Calculate CO2 Setpoint A = Trace Point CO2 minus 1.5% and enter it here:
 Setpoint A: _____
 EXAMPLE: Assume Trace Point CO2 = 13.0%
 Setpoint A = Trace Point CO2 minus 1.5% = 13.0% minus 1.5% = 11.5%
 - Measure the incoming combustion air temperature.
 - Using Chart 3, determine Setpoint B for the measured incoming combustion air temperature (choose the midpoint of the range) and enter it here:
 Setpoint B: _____
 - The Desired CO2 Setpoint is the lower of Setpoint A or Setpoint B. Enter it here:
 Desired CO2 Setpoint: _____
- Open the air setting to introduce additional excess air to reduce CO2 to the Desired CO2 Setpoint.

- Smoke reading should be ZERO. If not, increase air to obtain ZERO smoke.
- Lock the air setting.
- Recheck smoke and combustion.

Figure 7 - BECKETT NX AIR/HEAD SETTING

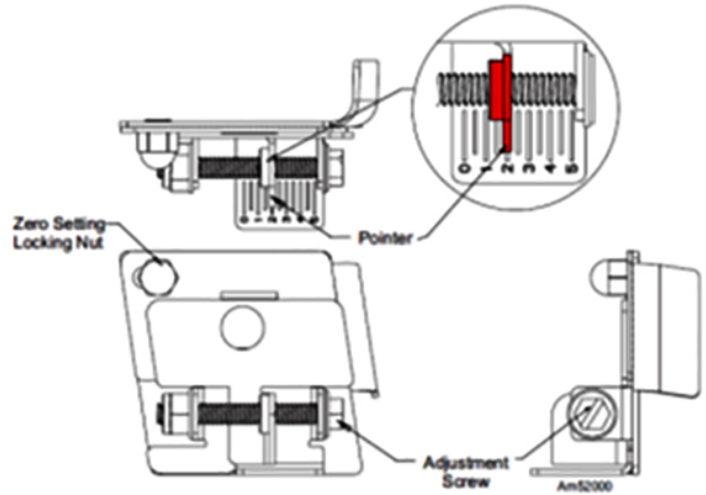

- Loosen splined nut on nozzle line about one turn.
- Turn air adjustment screw clockwise to increase air and counter clockwise to decrease air.
- Retighten splined nut after obtaining proper settings.

Figure 8 - RIELLO 40BF AIR DAMPER

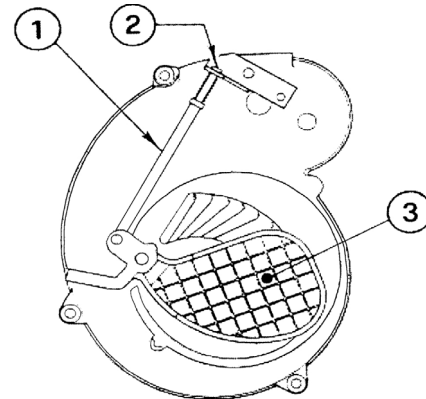

- To adjust the initial air damper setting, remove the burner cover and turn the air damper adjustment screw (2) until the top edge of the air damper (3) is in line with the corresponding number from Chart 2.
- Further adjustments must be made with the burner cover in place by removing the plastic plug on the cover.
- Turn the screw clockwise to increase combustion air or counter clockwise to decrease combustion air.
- When proper combustion and smoke spot readings are achieved, reinsert plastic cap over air adjustment hole.

NOTICE

Variations in CO2, smoke and temperature readings will be experienced with Riello burners when burner cover is in place. Burner cover must be in place when making measurements to ensure proper test results.

DIRECT VENTING OF OLSEN OIL FIRED FURNACES

Chart 1 - Beckett NX Oil Burner Setup (Pressure Switch Setpoint 0.65" WC)

Beckett NX Series Oil Burners							
(For use with direct vent units using outdoor combustion air only.)							
Furnace Model	Output [BTU/Hr]	Burner Model	Delavan Nozzle	Pump Pressure [PSIG]	Flow Rate [USGPH]	Low Firing Rate Baffle	Air Setting
LRF65NXU	65,000	NX56LQ	0.50/60°W	140	0.55	Yes	3
LRFV65NXU							
LRF80NXU	76,000	NX56LQ	0.50/60°W	175	0.65	Yes	3.25
LRFV80NXU							
LRF90NXU	87,000	NX56LQ	0.60/60°W	175	0.75	No *	3.25
LRFV90NXU							
LRF100NXU	98,000	NX56LQ	0.65/60°W	175	0.85	No *	3.75
LRFV100NXU							

* Burner is factory equipped with low firing rate baffle. Remove as shown for 0.75 and 0.85 USGPH firing rates.

Chart 2 - Riello 40BF Oil Burner Setup (Pressure Switch Setpoint 0.42" WC)

Riello 40BF3/40BF5 Series Oil Burners							
(For use with direct vent units using outdoor combustion air only.)							
Furnace Model	Output [BTU/Hr]	Burner Model	Delavan Nozzle	Pump Pressure [PSIG]	Flow Rate [USGPH]	Turbulator Setting	Air Setting
LRF65RBU	65,000	40BF3	0.50/90°B	125	0.55	0.0	4.25
LRFV65RBU							
LRF80RBU	76,000	40BF3	0.55/80°B	140	0.65	1.0	5.25
LRFV80RBU							
LRF90RBU	87,000	40BF5	0.65/80°B	140	0.75	0.0	3.75
LRFV90RBU							
LRF100RBU	98,000	40BF5	0.75/80°B	130	0.85	0.0	4.25
LRFV100RBU							

Note: Riello 40BF3 burner is required for 0.55 and 0.65 USGPH firing rates. Riello 40BF5 burner is required for 0.75 and 0.85 USGPH firing rates.

Chart 3 - CO2 Setting Versus Incoming Combustion Air Temperature to Achieve Approximately 20% Excess Air at 70°F Incoming Combustion Air Temperature

Incoming Combustion Air Temperature at Burner °F	Desired CO2% Range
-20	9.9 - 10.5
-10	10.1 - 10.7
0	10.4 - 11.0
10	10.6 - 11.2
20	10.9 - 11.5
30	11.1 - 11.7
40	11.4 - 12.0
50	11.7 - 12.3
60	11.9 - 12.5
70	12.2 - 12.8
80	12.4 - 13.0
90	12.7 - 13.3

9. FURNACE SET UP ADJUSTMENTS

Refer to Installation, Operation and Maintenance Manual provided with furnace for specific set up instructions. See Appendix A - Check Out and Adjustments, Section A.3 - Start UP.

10. BLOCKED VENT SAFETY SHUT OFF SYSTEM

Each direct vent furnace is equipped with a Blocked Vent Safety shut off system (BVS). This safety circuit will shut the burner off in the event of a combustion air blockage or venting blockage.

The components of this BVS consist of a pressure switch. The BVS is wired in series with the low voltage T-T connection on the oil primary control.

11. SEQUENCE OF OPERATION

1. Room temperature drops, thermostat calls for heat.
2. Pre-purge begins, lasting 5 to 15 seconds.
3. Oil solenoid energized
4. Oil Solenoid opens allowing oil to reach the Burner Electrodes. Burner ignition begins.
5. Cad cell detects light from combustion, disconnects the primary control safety circuit, allowing combustion to continue.
6. After 15 to 45 seconds (depending on primary control characteristics), the electric spark across the electrode tips stops, combustion continues.
7. The furnace blower will start after the programmed fan on delay as determined by the dipswitch settings on the electronic fan timer control.
8. Furnace continues to operate and will eventually reach "steady state", the point at which the system temperature stabilizes.
9. Room temperature rises, thermostat is satisfied, heating contacts open.
10. Oil Solenoid Valve closes, combustion stops, Burner Motor remains on to complete the Post Purge Cycle. Post Purge will continue up to 6 minutes depending on the control settings. Factory post purge setting is 30 seconds. This is recommended setting for typical applications.
11. The furnace blower will stop after the programmed fan off delay as determined by the dipswitch settings on the electronic fan timer control.
12. Furnace remains idle until next call for heat.

12. FINAL CHECK OUT

Before final test cycle, carefully examine complete vent system for leaks.

Verify all safety devices and electrical components have been set for normal operation. Verify all electrical connections are tight and wiring is secure.

IMPORTANT: Ensure homeowner is informed and understands:

1. where circuit breaker or fuse is located in main electrical panel.
2. where furnace switch is located, and switch "on" and "off" positions if not obvious.
3. where oil shut-off valve from oil storage tank is located.
4. to keep area around vent terminal free of snow, ice, and debris.
5. how to operate thermostat, and other related accessories.
6. how to operate manual reset button on primary control, and when not to push reset button.
7. how and where to visually inspect venting system for leaks or other problems.
8. how to inspect, clean and replace air filter, and other homeowner maintenance procedures.
9. who to call for emergency service and routine annual service.
10. terms and conditions of manufacturer's warranty and contractor's warranty.

DIRECT VENTING WIRING DIAGRAM

DIRECT VENTING WIRING DIAGRAM

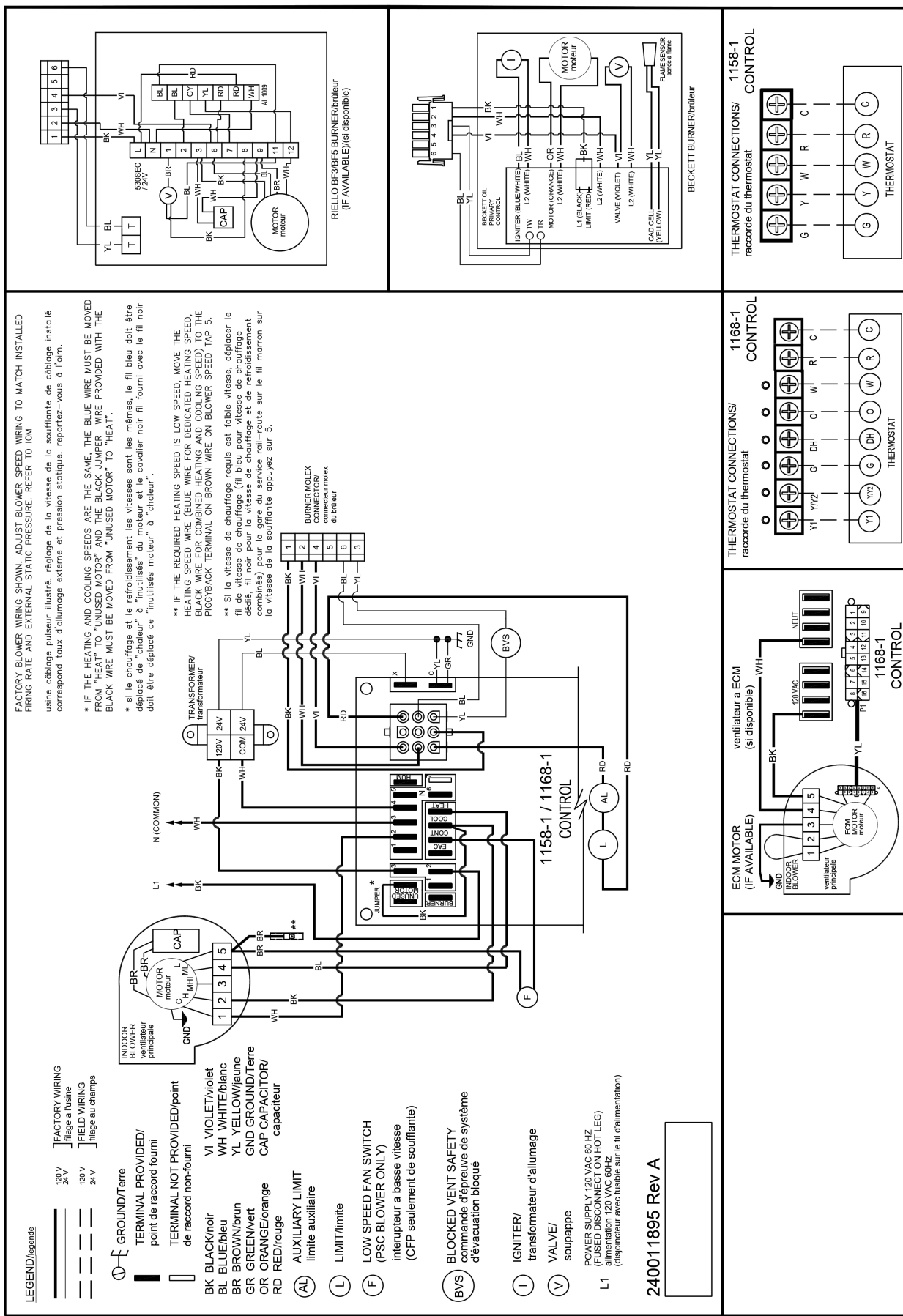

FACTORY BLOWER WIRING SHOWN. ADJUST BLOWER SPEED WIRING TO MATCH INSTALLED FIRING RATE AND EXTERNAL STATIC PRESSURE. REFER TO IOM.

usine coblage pulseur illustré. réglage de la vitesse de la soufflante de coblage installé correspond taux d'allumage externe et pression statique. reportez-vous à l'iom.

* IF THE HEATING AND COOLING SPEEDS ARE THE SAME, THE BLUE WIRE MUST BE MOVED FROM "HEAT" TO "UNUSED MOTOR" AND THE BLACK JUMPER WIRE PROVIDED WITH THE BLACK WIRE MUST BE MOVED FROM "UNUSED MOTOR" TO "HEAT".

* si le chauffage et le refroidissement les vitesses sont les mêmes, le fil bleu doit être déplacé de "chauffeur" à "inutilisés moteur" et le cavalier noir fil fourni avec le fil noir doit être déplacé de "inutilisés moteur" à "chauffeur".

** IF THE REQUIRED HEATING SPEED IS LOW SPEED, MOVE THE HEATING SPEED WIRE (BLUE WIRE FOR DEDICATED HEATING SPEED, BLACK WIRE FOR COMBINED HEATING AND COOLING SPEED) TO THE PROGRAMMABLE TERMINAL ON BROWN WIRE ON BLOWER SPEED TAP 5.

** Si la vitesse de chauffage requis est faible vitesse, déplacer le fil de vitesse de chauffage (fil bleu pour vitesse de chauffage dédié, fil noir pour la vitesse de chauffage et de refroidissement combinés) pour la gare du service rail-route sur le fil marron sur la vitesse de la soufflante appuyez sur 5.

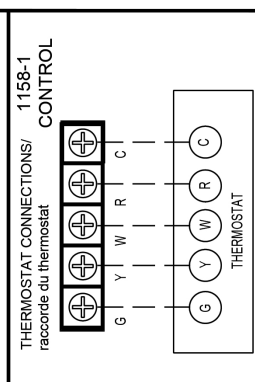
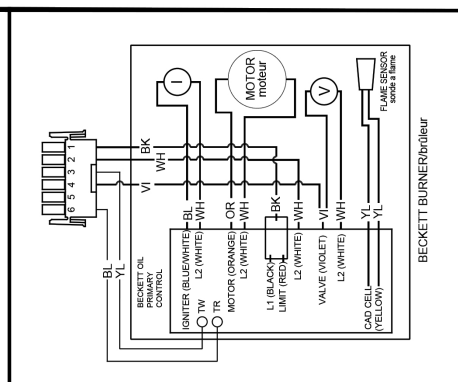
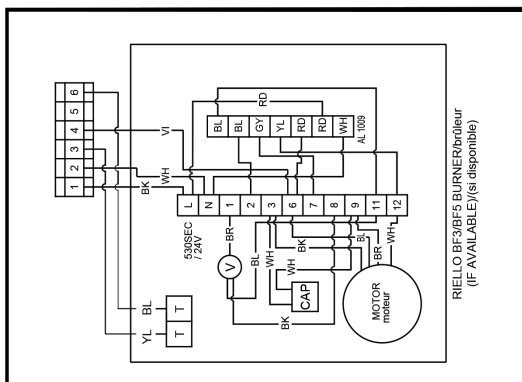
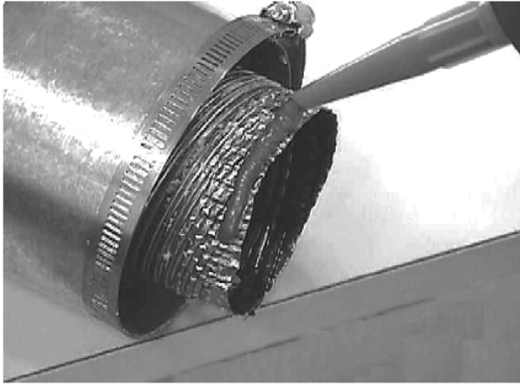
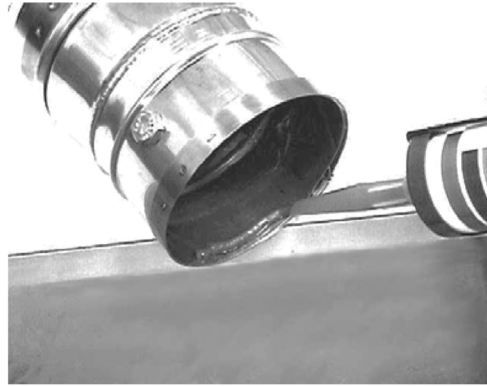

Figure 9 - VENTING COMPONENTS



Applying bead of silicone to the male portion of the appliance / vent adaptor.



Applying bead of silicone to the female portion of the appliance / vent adaptor.



Typical Standard Vent Terminal Installation.

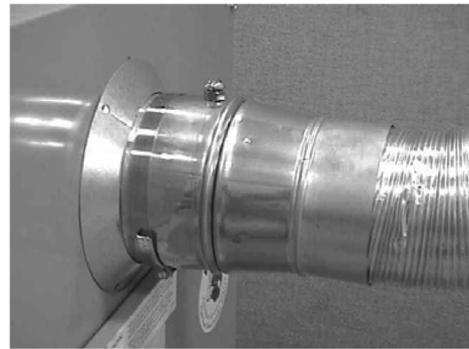

Typical Appliance Connector with test port.

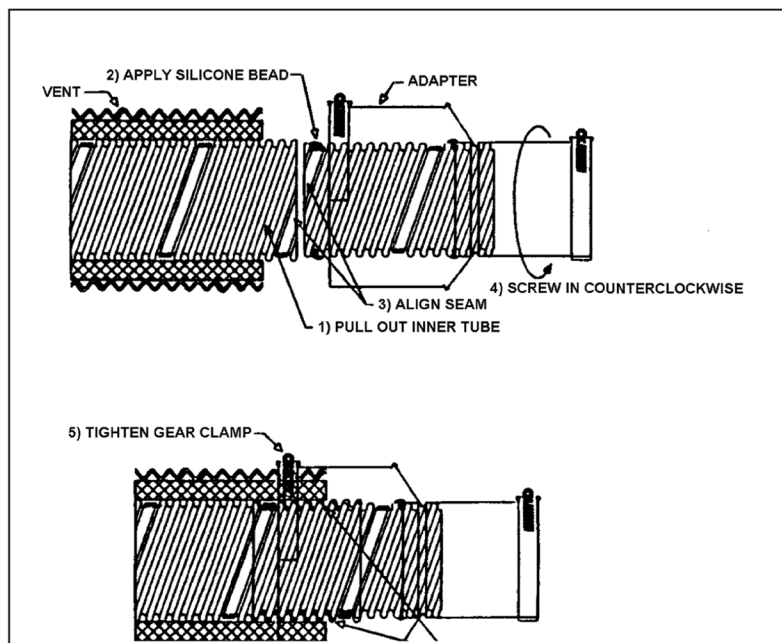

Figure 10 - Z-FLEX VENTING COMPONENTS / MATCHING GUIDE

Z-FLEX VENTING COMPONENTS / MATCHING GUIDE

Model	ITEMS INCLUDED WITH FURNACE		REQUIRED ITEMS ORDERED SEPARATELY				FIELD SUPPLIED COMPONENTS
			TERMINATION STD OR RISER		YOUR CHOICE OF		
	ITEM	P/N	ITEM	P/N	ITEM	P/N	
LRF(V)	5" X 4" Appliance Adapter	240011898	Oil Vent Terminal	28972	4" x 10' Vent Kit	240006909	Combustion Air Piping
			or		4" x 15' Vent Kit	240006910	
			Oil Vent Riser	29231	4" x 20' Vent Kit	240006911	

Also included with vent kits:
 Tube of Ultra Copper Sealant
 4" Vent Terminal Connector Part Number 240006914

Also included with burners, as applicable:

Combustion Air Intake Collar, 4" Straight for Beckett burner	Part Number 109005950
Combustion Air Intake Collar, 3" Straight for Riello burner	Part Number 109006030
Combustion Air Intake Pipe, 3" Elbow for Riello burner	Part Number 240011899
Combustion Air Intake Increaser, 3" x 4" for Riello burner	Part Number 240011310
Blocked Vent Safety Switch (Pressure Switch) 0.65" W.C. for Beckett burner	Part Number 240011862
Blocked Vent Safety Switch (Pressure Switch) 0.42" W.C. for Riello burner	Part Number 240011861
18" of Black Pressure Switch Tubing	Part Number 30705
22" of Grey Pressure Switch Tubing	Part Number 11344

Figure 11 - DIRECT VENT PARTS IDENTIFICATION

ILLUSTRATION	DESCRIPTION	PART NO.	USED WITH
	5" x 4" Appliance Adapter	240011898	LRF(V)

Figure 12 - BECKETT BURNER WITH BLOCKED VENT SAFETY (BVS) OPERATION

EXTERNAL ACTION	APPLIANCE RESPONSE
Power applied to 7505P control	Internal safety check conducted. If no light or flame is detected and all internal conditions are correct, control enters idle mode.
Thermostat calls for heat.	<ol style="list-style-type: none"> 1. Contacts between T and T on 7505P are closed. 2. Primary Control Safety period (4 seconds) internal and external check for flame or light. If flame is detected, control remains in idle mode. 3. When flame is not present, 7505P will apply power to the burner motor and igniter, complete a 15 second valve on delay period and then apply power to the oil valve circuit. 4. Enters the trial for ignition period. <ol style="list-style-type: none"> A. Monitors burner for flame. B. When flame is not detected: <ol style="list-style-type: none"> i. Enters lockout mode after 15 seconds. ii. Shuts off valve, igniter and burner motor. iii. Flashes indicator light at 1 Hz (½ second on, ½ second off). iv. Depress reset button to return to power up sequence. C. When flame is detected, Carry-Over period begins: 5. Enters 10-second Ignition Carry-Over period. <ol style="list-style-type: none"> A. Turns on indicator light B. If flame is lost and lockout time has not expired, THE PRIMARY CONTROL returns to trial for Ignition period. C. If flame is lost and lockout time has expired, THE PRIMARY CONTROL enters Recycle Mode. 6. Carry-over time expires and igniter turns off. 7. Enters a run mode: <ol style="list-style-type: none"> A. Flame is monitored until call for heat ends or flame is lost. If flame is lost: <ol style="list-style-type: none"> i. Control enters Recycle Mode. ii. Recycle time starts (60 seconds). iii. Burner and valve are turned off. iv. Red Light Flash → Safety Lockout Red Light Solid → Hard Lockout v. Returns to Idle mode at end of Recycle mode.
Call for heat is satisfied.	<ol style="list-style-type: none"> 1. Oil valve circuit is de-energized and valve shuts off. 2. Burner motor runs for selected burner motor-off delay. 3. Burner motor turns off. <p>Returns to Idle mode</p>
Reset button pushed two times without device completing a call for heat.	<ol style="list-style-type: none"> 1. Enters restricted Hard Lockout. 2. Indicator light on continuously 3. Reset device by pressing and holding reset button for a minimum of 15 seconds. (Yellow Light Turns ON)
Pressure switch contacts open and cause burner to recycle	<p>In the event of vent or combustion air intake blockage, the blocked vent safety switch (pressure switch) contacts will open, opening the contacts between T and T on the 7505P primary control, as if ending the call for heat. Once the post purge period (burner motor off delay) ends, the burner motor will shut off and the pressure switch contacts will re-close, again closing the T-T contacts and starting the burner motor. If the vent or combustion air intake blockage remains, the pressure switch contacts will open again once the burner motor is running, and shut the burner motor off. Continuous cycling of this type indicates vent or combustion air intake blockage.</p>

Figure 13 - BECKETT BURNER TROUBLESHOOTING

Condition 1: Burner motor does not start when there is a call for heat.		
Procedure	Status	Corrective Action
1. Check that limit switches are closed and contacts are clean.	N/A	N/A
2. Check for line voltage power at the oil primary control. Voltage should be 120 Vac between the black and white lead wires on the oil primary control.	N/A	N/A
3. Check indicator light with burner off, no call for heat (no flame).	Indicator light is on.	Cad cell is defective, sees external light, or connections have shorted. Go to step 4.
	Indicator light is off.	Go to step 5.
4. Shield cad cell from external light.	Indicator light turns off.	Eliminate external light source or permanently shield cad cell.
	Indicator light stays on.	<ul style="list-style-type: none"> • Replace cad cell with new cad cell and recheck. • If indicator light does not turn off, remove cad cell lead wires from and recheck. • If indicator light is still on, replace control. • If the indicator light turns off, replace cad cell bracket assembly.
5. Verify that the oil valve is closed during the "valve on delay" period by observing the view port and verifying that no flame is present during the 15-second "valve on delay".	Indicator light is on.	If flame is present, replace the oil valve.
6. Confirm BVS pressure switch contacts closed.	Contacts closed	- Go to step 7
	Contacts open	- Replace BVS pressure switch
7. Jumper thermostat (T -T) terminals on 7505P IMPORTANT First remove one thermostat lead wire.	Burner starts.	Trouble is in thermostat circuit. Check thermostat-wiring connections. If connections are clean and tight, check thermostat wires for continuity.
	Burner does not start.	<ul style="list-style-type: none"> • Disconnect line voltage power and open line switch. • Check all wiring connections. • Tighten any loose connections and recheck. • If burner still doesn't start, replace 7505P.
		If burner still doesn't start, check the oil burner motor. It may be seized or burned out.
Condition 2: Burner starts then locks out on safety with indicator light flashing at 1/2 second on, 1/2 second off.		
Procedure	Status	Corrective Action
1. Reset oil primary control by pushing in and releasing red reset button. Flash - 1 sec. / Solid - 1 sec.	Indicator light stops flashing.	Go to Step 2.
	Indicator light continues to flash at 1/2 second on, 1/2 second off rate.	Verify that the control is not in restricted mode. (See notes at end of this table.). If not in restricted mode, replace 7505P
2. Listen for spark after burner turns on (after 2 second delay).	Ignition is off	Spark igniter could be defective. Check for line voltage at igniter terminals. If line voltage is present, replace 7505P.
	Ignition is on.	Go to Step 3.
	Ignition is on but no oil is being sprayed into the combustion chamber.	Wait for "Valve ON" delay to complete. 1. Check oil supply. 4. Check oil line valve. 5. Check for filter blockage or seized oil pump.

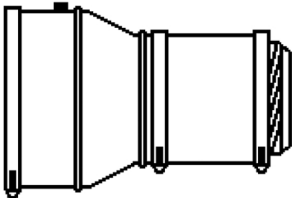
Figure 13 - BECKETT BURNER TROUBLESHOOTING - continued

3. Check indicator light after flame is established, but before oil primary control locks out.	Indicator light is on until the control locks out and starts flashing during lockout.	Replace 7505P
	Indicator light stays off.	Go to step 4.
4. Check cad cell sighting for view of flame. a. Disconnect line voltage power and open line switch. b. Unplug cad cell and clean cad cell face with soft cloth. Check sighting for clear view of flame. Replace cad cell in socket. c. Reconnect line voltage power and close line switch. d. Start burner.	Burner locks out	Go to step 5.
	Burner keeps running.	System is OK.
5. Check cad cell. a. Disconnect line voltage power and open line switch. b. Remove existing cad cell and replace with new cad cell. c. Disconnect all wires from thermostat terminals to ensure that there is no call for heat. d. Reconnect line voltage power and close line switch. e. Expose new cad cell to bright light such as a flashlight.	Indicator light is on.	Remount control onto burner housing, go to step 6.
	Indicator light is off.	System is OK.
6. Check cad cell bracket assembly. a. Disconnect line voltage power and open line switch. b. Remove cad cell wires from quick connect connectors on the R7505P and leave control lead wires open. c. Apply power to device. d. Place jumper across cad cell terminals after	Indicator light is on.	Replace CAD cell bracket assembly.
	Indicator light is off.	Replace 7505P

NOTE: Hard Lockout : In order to limit the accumulation of unburned oil in the combustion chamber, the control can be reset only 5 times, after which, the control locks out. The reset count returns to zero each time a call for heat is successfully completed.

To reset from Hard Lockout: press and hold the reset button for 15 seconds. When the Yellow LED flashes turns on, the device has reset.

NOTE: Disable function: Pressing and holding the reset button will disable all functions until the button is released. The burner will restart at the beginning of the normal heat cycle on SAFETY CHECK.

Condition 3: Burner motor continuously cycles on and off without trying to light burner.

- Blocked vent safety switch (pressure switch) contacts opening each time burner motor starts
- Check venting for blockage
- Check combustion air intake air pipe for blockage
- Check pressure switch hoses for possible obstruction

Figure 14 - RIELLO 40BF With BLOCKED VENT SAFETY (BVS) OPERATION

EXTERNAL ACTION	APPLIANCE RESPONSE
Thermostat calls for heat.	<ol style="list-style-type: none"> 1. Contacts between T and T on oil burner primary control are closed. 2. Burner enters pre-purge. 3. After pre-purge, oil valve is energized and burner lights off. 4. Burner operates in run mode.
Call for heat is satisfied.	<ol style="list-style-type: none"> 1. Oil valve circuit is de-energized and valve shuts off. 2. Burner motor runs for duration of burner motor-off delay. 3. Burner motor turns off.
Pressure switch contacts open and cause burner to re-cycle	In the event of vent or combustion air intake blockage, the blocked vent safety switch (pressure switch) contacts will open, opening the contacts between T and T on the oil burner primary control, as if ending the call for heat. Once the post purge period (burner motor off delay) ends, the burner motor will shut off and the pressure switch contacts will re-close, again closing the T-T contacts as if calling for heat and starting the burner motor as described above. If the vent or combustion air intake blockage remains, the pressure switch contacts will open again once the burner motor is running, and shut the burner motor off. Continuous cycling of this type indicates vent or combustion air intake blockage.

Figure 15 - RIELLO 40BF BURNER TROUBLESHOOTING

Condition: Thermostat is calling for heat. Burner is not running.		
Problem	Possible Cause	Remedy
1. Reset control box.	Burner starts.	Go to step #4.
	Burner does not start	Go to step #2
2. Test for 120 Vac supply at sub-base between L (P) & N or terminals #3 and #5.	120 Vac present.	Go to step #3
	No voltage	<ul style="list-style-type: none"> • Check system fuse, breaker or ensure service switch is ON. • Verify all limits are closed. • If using switching relay, verify 24 Vac at T-T.
3. Confirm BVS pressure switch contacts closed.	Contacts Closed	Go to step #4
	Contacts Open	Replace BVS
4. Turn off power supply- Remove control box and jumper terminals #5 and #6. Restore power.	Motor runs.	<ul style="list-style-type: none"> • Verify reduced voltage (42-52 Vac) between terminals #3 and #7. • Ensure good contact between control box spades and sub-base terminals. • Defective control box/ Replace.
	Motor does not run.	<ul style="list-style-type: none"> • Verify electrical connections. • Check for seized pump, motor, or fan against housing. • Defective motor capacitor. • Thermal overload (Hot motor).
5. Burner Starts	Burner stays in Pre-purge.	<ul style="list-style-type: none"> • Faulty CAD cell or seeing light before trial for ignition. • Coil wires on terminals #1 and #2 or #1 and #8 reversed. • Open coil circuit; terminals #2 and #8. • Open coil circuit; terminal #1 • Defective 42-52 Vac supply, terminals #3 and #7. • Defective control box/ Replace
	Burner continues to purge and light off with immediate flame dropout.	<ul style="list-style-type: none"> • Metal yoke for coil missing. • Coil wire #2 and #8 reversed. • Low resistance of coil holding circuit, terminals #1 and #2, (1350 ohms ± 10%).. • Verify BVS pressure switch is remaining closed upon light off.
	Burner locks out after trial for ignition.	<ul style="list-style-type: none"> • Low resistance or no contact on starting circuit of coil, terminals #2 and #8. (1.3-ohm ± %) • No oil supply- tank empty, valve closed, dirty filter, damaged supply lines. • Defective or dirty oil valve stem, nozzle, or pump strainer. • Broken pump drive key, defective pump or no oil pressure. • Ignition electrodes shorted, cracked porcelain. • Burner motor not up to speed. • Excessive draft over fire. • Defective control box/ Replace.
6. Burner motor continuously cycles on and off without trying to light the burner.	Blocked Vent Safety Switch (Pressure Switch) Opening	<ul style="list-style-type: none"> • Check venting for blockage • Check combustion air intake pipe for blockage • Check pressure switch operation. Confirm contacts closed when furnace not running. • Check pressure switch tubes for possible obstruction

HOMEOWNER'S REFERENCE TABLE	
Model No.	
Serial No.	
Date Installed	
Contractor	
Contact	
Address	
Postal Code	
Telephone No.	
After Hours No.	
FUEL SUPPLIER	
Fuel Oil Supplier	
Contact	
Telephone No.	
After Hours No.	
IF DIFFERENT FROM INSTALLATION CONTRACTOR:	
Service Tech.	
Telephone No.	
After Hours No.	



2201 Dwyer Avenue, Utica, NY 13501

Tel. 800 253 7900

www.ecrinternational.com

All specifications subject to change without notice.

©2018 ECR International, Inc.