



**PRODUCT LITERATURE**

Lennox Industries Inc.  
Dallas, Texas

# INSTALLATION INSTRUCTIONS

## COWB3 OIL FIRED BOILER



**RETAIN THESE INSTRUCTIONS FOR  
FUTURE REFERENCE**

*These instructions must be affixed on  
or adjacent to the boiler.*



### **WARNING**

Improper installation, adjustment, alteration, service, or maintenance could result in death or serious injury. Refer to this manual for assistance. For additional information consult a qualified installer, service agency, or the oil supplier.



Tested For 50 psi.  
ASME  
Working Pressure

### **OIL FIRED BOILERS**

These boilers are low pressure, sectional cast iron boilers constructed and hydrostatically tested for a maximum working pressure of psi in accordance with A.S.M.E. (American society of Mechanical Engineers) Section IV Standards for cast iron heating boilers.

## SAFETY NOTICES

Safety Notices .....	2
Boiler Ratings And Capacities .....	3
Safe Installation And Operation .....	4
Locating The Boiler.....	5
Fresh Air For Combustion.....	7
System Piping.....	9
System Piping Arrangement .....	15
Chimney And Chimney Connections.....	16
Typical Chimney Connection .....	17
Electrical Connections .....	18
Filling The Boiler .....	19
Operating The Boiler .....	20
Checking And Adjusting Controls .....	23
Maintenance.....	24
Oil Boiler / Burner Cleaning Instructions .....	25
Oil Burner Cleaning .....	26
Service Hints .....	27
Electrical Wiring.....	28
Equipment and Optional Accessories.....	30

### Introduction

Conservator 2 water boiler is a natural draft oil fired hot water boiler comprised of cast iron sections. Conservator 3 Water boiler is available with 3, 4, or 5 cast iron sections. These sections are held together by cast iron push nipples.

Conservator 2 water boiler is capable of firing #2 fuel oil from 0.65 gph up to 1.75 gph. All packaged boilers include a swing door, Honeywell limit, temperature and pressure gauge, safety relief valve, drain valve, flue brush, and extra boiler tap for expansion tank or air elimination.

Boiler installation shall be completed by qualified agency.

**Become familiar with symbols identifying potential hazards.**



This is the safety alert symbol. Symbol alerts you to potential personal injury hazards. Obey all safety messages following this symbol to avoid possible injury or death.

### **DANGER**

Indicates a hazardous situation which, if not avoided, WILL result in death or serious injury

### **WARNING**

Indicates a hazardous situation which, if not avoided, could result in death or serious injury.

### **CAUTION**

Indicates a hazardous situation which, if not avoided, could result in minor or moderate injury.

### **NOTICE**

Used to address practices not related to personal injury.

# BOILER RATINGS AND CAPACITIES

**Figure 1 - Dimensions**

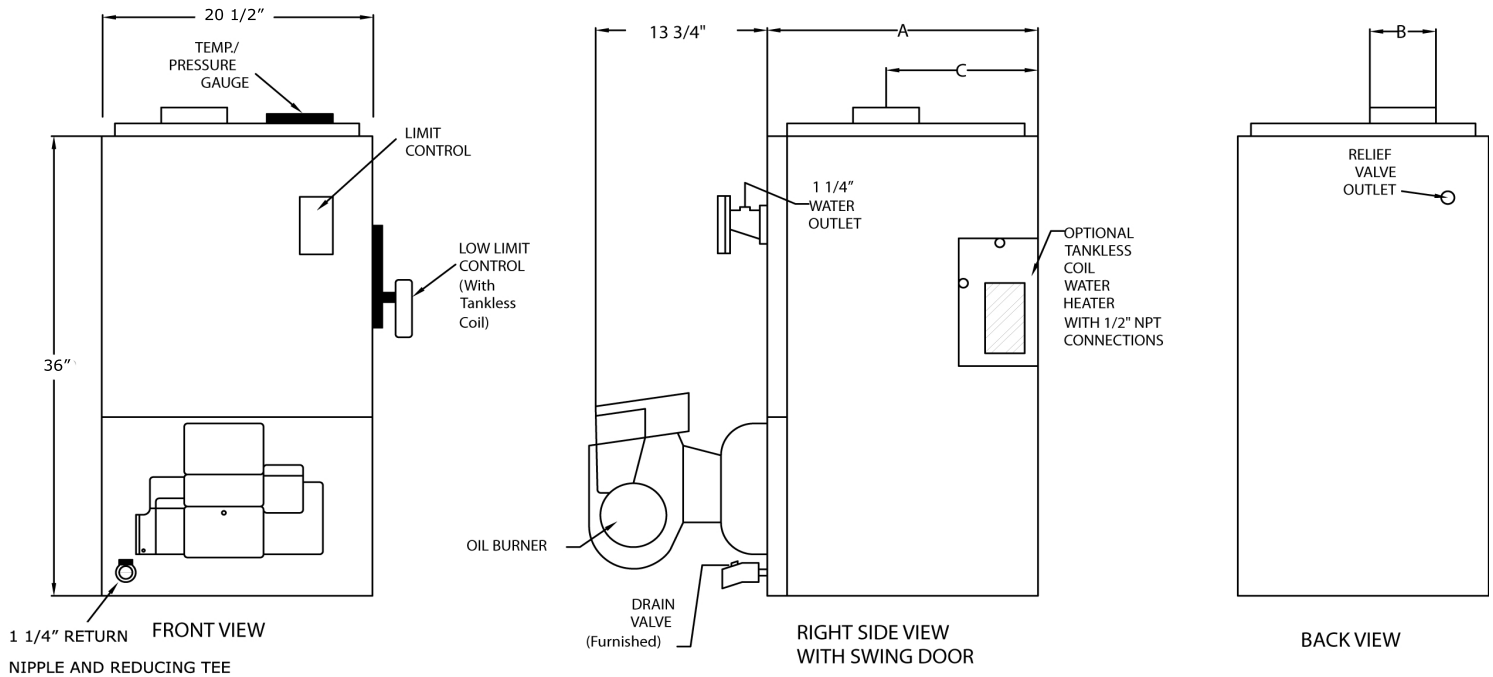

## BOILER RATINGS AND CAPACITIES

BOILER MODEL NO.	INPUT		**HEATING CAPACITY *Mbh	‡NET AHRI RATING WATER *Mbh	A.F.U.E. ++	NO. SEC.	MINIMUM CHIMNEY SIZE/ HEIGHT	DIMENSIONS (inches)		
	+gph	*Mbh						A	B	C
COWB3-3-.65	0.65	91	80	70	86.3	3	8" X 8" X 15"	14½	6	8
COWB3-3-.75	0.75	105	92	80	85.2	3	8" X 8" X 15"	14½	6	8
COWB3-3-1.00	1.00	140	120	104	84.0	3	8" X 8" X 15"	14½	6	8
COWB3-4-.90	0.90	126	111	97	86.0	4	8" X 8" X 15"	17¾	6	9⅝
COWB3-4-1.25	1.25	175	151	131	85.0	4	8" X 8" X 15"	17¾	6	9⅝
COWB3-4-1.50	1.50	210	179	156	84.0	4	8" X 8" X 15"	17¾	6	9⅝
» COWB3-5-1.20	1.20	168	147	128	86.5	5	8" X 8" X 15"	21	6	11½
COWB3-5-1.75	1.75	245	210	183	84.3	5	8" X 8" X 15"	21	6	11½

\* Mbh = 1,000 BTU per hour [BTU = British Thermal Unit]  
 \*\*Heating Capacity based on 13% CO<sub>2</sub> with a -0.02" w.c. draft over fire, and a #1 smoke or less. Testing was done in accordance with the D.O.E. (Department of Energy) test procedure.  
 + gph = Gallons per hour oil at 140,000 BTU per gallon  
 ++A.F.U.E. = Annual Fuel Utilization Efficiency based upon D.O.E. test procedure.  
 ‡ Net AHRI Water Ratings based on piping and pickup allowance of 1.15. Consult manufacturer before selecting boiler for installations having unusual piping and pickup requirements, such as intermittent system operation, extensive piping systems, etc.  
 >>Per Energy Star specifications, AFUE is rounded to the nearest whole percentage point. As such, this product qualifies for Energy Star.

## SAFE INSTALLATION AND OPERATION

### NOTICE

This boiler has been designed for residential installations. If used for commercial applications, all jurisdictional requirements must be met. This may require wiring and/or piping modifications. Manufacturer is not responsible for any changes to the original design.

1. Read the Owner's Manual for Safe Operation. Failure to follow rules for safe operation and instructions can cause malfunction of boiler and result in death, serious bodily injury, and/or property damage.
2. Install boiler in accordance with requirements of authority having jurisdiction, or in the absence of such requirements : United States, NFPA 31: Installation of Oil Burning Equipment
3. Before servicing, allow boiler to cool. Always shut off any electricity and oil to boiler when working on it.
4. Inspect oil line and connections for leaks.
5. Be certain oil burner nozzle is the size required. Over-firing will result in early failure of the boiler sections. This will cause dangerous operation.
6. Never vent this boiler into enclosed space. Always vent to outside. Never vent to another room or inside a building.
7. Be sure there is adequate air supply for complete combustion.
8. Follow regular service and maintenance schedule for efficient and safe operation.
9. Keep boiler area clean and free of combustible material, gasoline and other flammable vapors and liquids.
10. Oil burners are not do-it-yourself items. This boiler must be installed and serviced by qualified professionals using combustion test instruments.

### WARNING

Burn and scald hazard. Safety relief valve could discharge steam or hot water during operation. Install discharge piping per these instructions.

11. Be aware when piping the safety relief valve if system pressure exceeds safe limit of 30 pounds per square inch, the safety relief valve will automatically lift open. Lifting of the safety relief valve can discharge large quantities of steam and hot water, which may damage the surroundings. Before installing the safety relief valve read the manufacturer's instructions and maintenance section of the manual on safety relief valves.
12. Installation and sizing of the expansion tank must consider heating systems total water volume, temperature, boiler initial fill pressure, and system arrangement. Improperly installed and sized expansion tank may result in frequent lifting of the safety relief valve or other heating system problems. For proper installation, sizing, and maintenance of the expansion tank follow guidelines established by tank manufacturer.
13. Expansion tank performance and life expectancy can be hindered by overfilling the boiler. Recommend initial fill pressure of 10-12 psig. For higher fill pressures expansion tank's air charge will need to be increased to match fill pressure. Consult manufacturer's guidelines for sizing and selection.
14. Purging the heating system of air and gases when first putting boiler into service is critical for proper circulation and quiet performance. Once air and gases are purged, for boiler installations using float type vents, air vents should be closed for normal operation. If air is heard or noticed by loss of heat, purge system and open vents for short period of time.

**DO NOT USE GASOLINE CRANKCASE DRAININGS OR ANY OIL CONTAINING GASOLINE.**

## LOCATING THE BOILER

### Complete Prior To Installing Boiler.

- A. Verify you have selected the right size boiler with proper capacity. AHRI rating of boiler selected should be greater than or equal to calculated peak heating load (heat loss) for building or area(s) served by boiler and associated hot water heating systems. See boiler rating and capacity table previously listed in this manual. Any heat loss calculations used should be based on approved methods.
- B. Boiler must be supplied with proper oil supply and oil piping, sufficient fresh combustion air, and suitable electrical supply.
- C. Boiler must be connected to suitable venting system and piping system adequate to distribute heating load.
- D. Properly locate and install thermostat for heating system control.

Any doubts as to requirements, check with local authorities and obtain professional help where needed. OPERATING INSTRUCTIONS, FINAL CHECKS AND ADJUSTMENTS, and MAINTENANCE sections in this manual are vital to the proper and safe operation of the heating system.

1. Place boiler in location centralized with the piping system and as close to chimney as possible.
2. Boiler must be level. If necessary use metal shims beneath boiler's feet.
3. Use raised base if floor can become wet or damp.
4. Maintain clearances for fire safety as well as servicing. 18" clearance must be maintained at side where passage is required for access to another side for cleaning, servicing, inspection or replacement of any parts that may normally require attention. Install boilers at least 6" from combustible material on left side, rear, and above, and at least 24" on right side and front. Allow at least 24" accessibility clearance above for servicing.
5. Fresh air for combustion must be available at front of the boiler. Fresh air for ventilation must be available to front **and** rear of boiler. Air passages must be free of obstructions at all times. Ventilating and combustion air must enter boiler room without restrictions.

### ⚠ WARNING

Fire hazard. Do not install boiler on combustible flooring or carpeting. Failure to follow these instructions could result in death or serious injury.

6. Floor supporting boiler must be noncombustible and sufficiently stable. If it is combustible, place boiler on 2" concrete patio blocks or 2" Cladlite Pad™. Blocks or pad must be under entire boiler to protect the floor.
7. Install boiler in accordance with requirements of authority having jurisdiction, or in the absence of such requirements: United States. NFPA31: Installation of Oil Burning Equipment

**Figure 2 - Clearances**

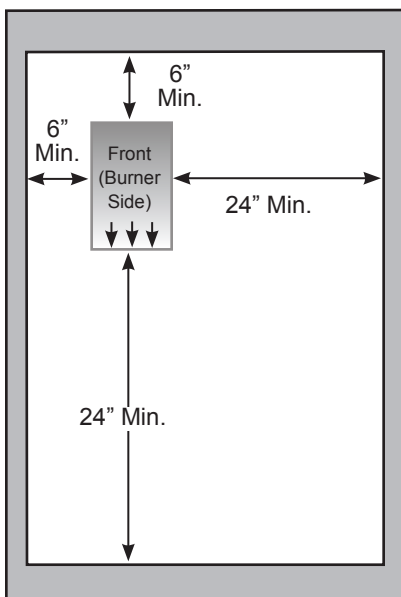

BOILER CLEARANCES			
Unit	Combustible Clearance	Accessibility, Cleaning, and Servicing	Flue to Combustible Clearance
Top	6"	24"	9"
Left Side	6"		
Right Side	24"		
Base	non-combustible		
Front	24"		
Back	6"		

*All distances measured from the cabinet of the boiler.*

Figure 3 - Boiler With Piping System

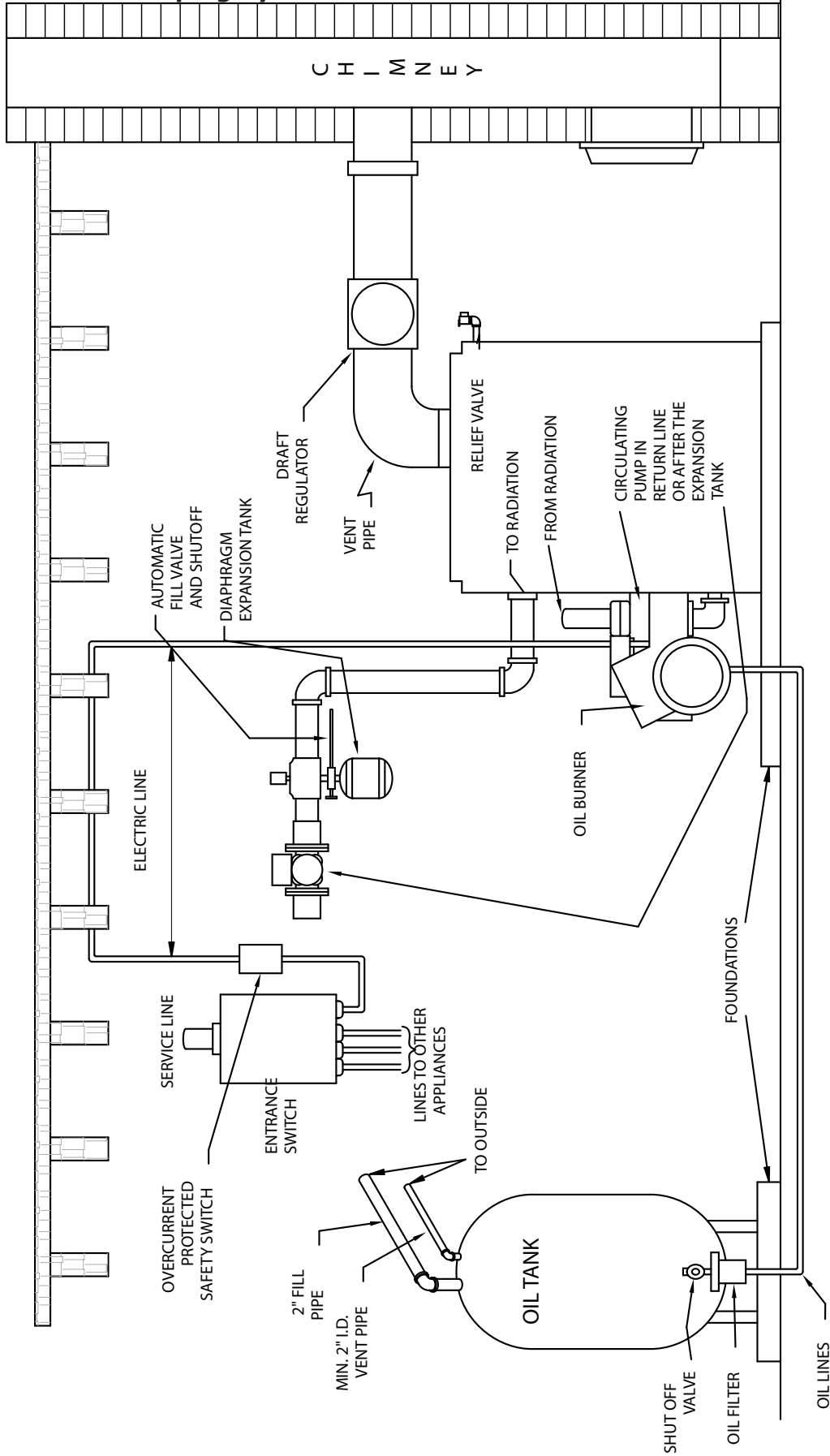

GENERAL PRINCIPAL REQUIREMENTS FOR A TYPICAL INSTALLATION

## FRESH AIR FOR COMBUSTION

### **WARNING**

Asphyxiation, fire hazard. Do not obstruct air openings to combustion area. Follow instructions below, to maintain adequate combustion air.

### **NOTICE**

Install outside air intake if you use fireplace or kitchen or bathroom exhaust fan. These devices rob boiler and water heater of combustion air.

Provide adequate supply of combustion air in accordance with requirements of authority having jurisdiction. In absence of such requirements: United States. NFPA 31: Installation of Oil Burning Equipment

#### **EXAMPLE 1: Boiler Located in Unconfined Space**

If your boiler is in an open area (un-partitioned basement) in conventional house, air that leaks through cracks around doors and windows will usually be adequate to provide air for combustion. Doors should not fit tightly. Do not caulk cracks around windows.

An unconfined space is defined as space whose volume is not less than 50 cubic feet per 1,000 Btu per hour of total input rating of all appliances installed in that space.

#### **EXAMPLE 2: Boiler Located in Confined Space**

**A. All Air from Inside the Building:** Confined space shall be provided with two permanent openings communicating directly with additional room(s) of sufficient volume so the combined volume of all spaces meets the criteria for unconfined space. Total input of all combustion equipment installed in combined space shall be considered in making this determination. Each opening shall have minimum free area of one square inch per 1,000 Btu per hour of total input rating of all combustion equipment in the confined space, but not less than 100 square inches. One opening shall be within 12 inches of top and one within 12 inches of bottom of the enclosure.

Example: Your boiler is rated at 100,000 Btu per hour. Water heater is rated at 30,000 Btu per hour. Total is 130,000 Btu per hour. You need two grilles, each with 130 square inches of FREE opening. Metal grilles have about 60% FREE opening. To find louvered area needed, multiply free opening required by 1.7 ( $130 \times 1.7 = 221.0$  sq. in. louvered area). In this example, two grilles each having 8" x 30" (240 sq. in.) louvered area would be used.

**Figure 4 - Air Openings For Boiler Located In Confined Space (Utility Room)**

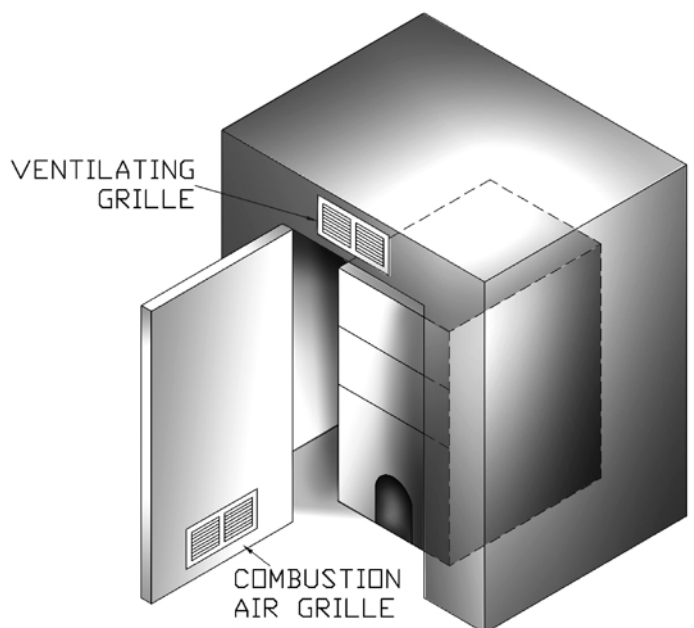

## FRESH AIR FOR COMBUSTION

**B.** All Air from Outdoors: Confined space shall be provided with two permanent openings, one commencing within 12 inches of top and commencing within 12 inches of bottom of enclosure. Openings shall communicate directly, or by ducts, with outdoors or spaces (crawl or attic) that freely communicate with outdoors.

1. When directly communicating with outdoors, each opening shall have minimum free area of one square inch per 4,000 Btu per hour of total input rating of all equipment in the enclosure.
2. When communicating with outdoors through vertical ducts, each opening shall have minimum free area of one square inch per 4,000 Btu per hour of total input rating of all equipment in the enclosure.

3. When communicating with outdoors through horizontal ducts, each opening shall have minimum free area of one square inch per 2,000 Btu per hour of total input rating of all equipment in the enclosure.
4. When ducts are used, they shall be of same cross sectional area as free area of openings to which they connect. Minimum dimension of rectangular air ducts shall be not less than three inches.

**Figure 5 - Fresh Air Duct Capacities For Ducts Supplying Fresh Air To Boiler In Tightly Constructed Houses**

<b>FRESH AIR DUCT CAPACITIES THROUGH LOUVERS</b>			
Fresh Air Duct Size	¼" Mesh Screen	Wood Louvers	Metal Louvers
	(Btuh)*	(Btuh)*	(Btuh)*
3 ½" x 12"	144,000	36,000	108,000
8" x 8"	256,000	64,000	192,000
8" x 12"	384,000	96,000	288,000
8" x 16"	512,000	128,000	384,000

*\*Btuh = British Thermal Units per hour based on opening covered by ¼" mesh screen, wood louvers, or metal louvers.*

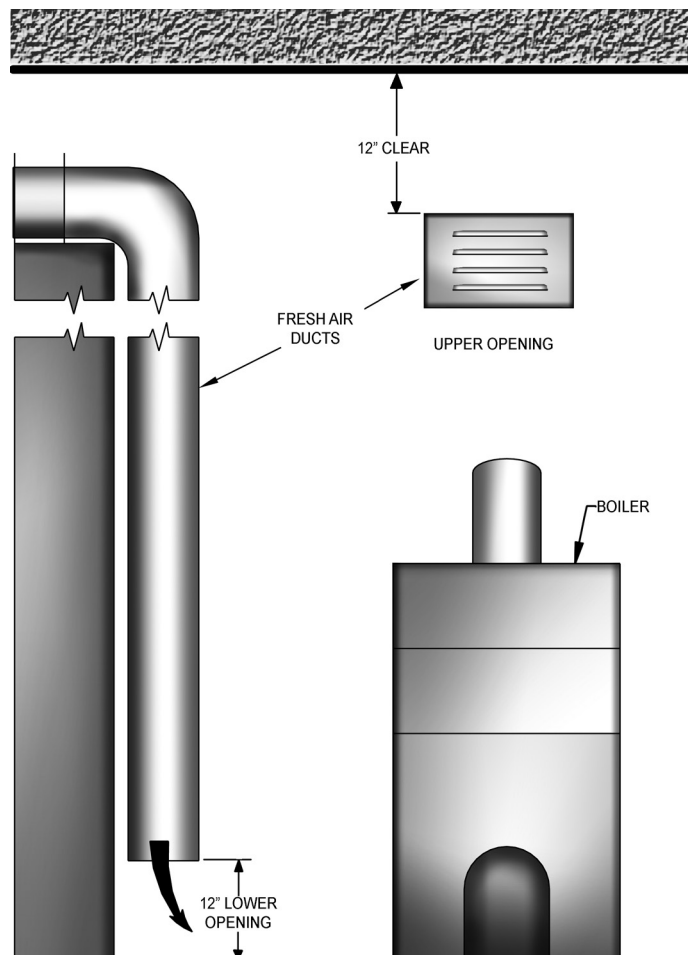



## SYSTEM PIPING

### 1. Installation of boiler for new heating system,

Install all of radiation units (panels, radiators, baseboard, or tubing) and supply and return mains first. After all heating system piping and components have been installed, make final connection of system piping to boiler. It is recommended to mount circulating pump on supply side piping, such that it pumps away from expansion tank. Refer to figures on next pages.

2. Equip hot water **boiler installed above radiation level** with low water cut off device. Periodic inspection is necessary, as is flushing of float type devices, per low water cut off manufacturer's specific instructions.

3. **Packaged boiler is set up with 1¼" NPT supply and return piping** from front of boiler. Boiler supply and return piping can be moved to rear of boiler. Boiler should not be piped return line to front, supply line to rear, or vice versa, will cause boiler water to short circuit heat exchanger. Piping connections may require additional fittings and parts.

4. **Install drain valve** provided with boiler in return tee. See figure 1.

5. **Install Safety Relief valve** in rear section using ¾" nipple and street elbow provided with boiler. See figure 6.

- A. Install safety relief valve with spindle in vertical position.
- B. Do not install shutoff valve between boiler and safety relief valve.
- C. Install discharge piping from safety relief valve.
  - Use ¾" or larger pipe.
  - Use pipe suitable for temperatures of 375°F (191°C) or greater.
  - Individual boiler discharge piping shall be independent of other discharge piping.
  - Size and arrange discharge piping to avoid reducing safety relief valve relieving capacity below minimum relief valve capacity stated on rating plate.
  - Run pipe as short and straight as possible to location protecting user from scalding and properly drain piping.
  - Install union, if used, close to safety relief valve outlet.
  - Install elbow(s), if used, close to safety relief valve outlet and downstream of union (if used).
  - Terminate pipe with plain end (not threaded).

6. **Verify clean cold water supply is available** when connecting to pressure reducing valve. When water supply is from well or pump, a sand strainer should be installed at the pump.

### Low Design Water Temperature Systems (Below 140° F) And Large Water Content Systems

- Significant condensation may form in this boiler and/or venting system if boiler is operated with return temperatures of less than 120°F.
- Condensation is corrosive and can eventually cause damage to boiler and venting system. Minimum design return water temperature to prevent this condensation in boiler and venting is 120°F.
- Boiler used in heating system where design water temperatures below 140°F are desired (e.g. radiant floor heating), a 3-way or 4-way mixing valve or suitable alternative (e.g. Bypass Piping Arrangement shown in diagram on following page) is required to prevent low temperature (below return 120°F) return water from entering boiler. When using mixing valve, follow manufacturer's installation instructions.
- Boiler connected to system having large water content (such as former gravity system), use of Bypass Piping Arrangement shown in diagram on following page is suggested.

**Figure 6 - Safety Relief Valve Installation**

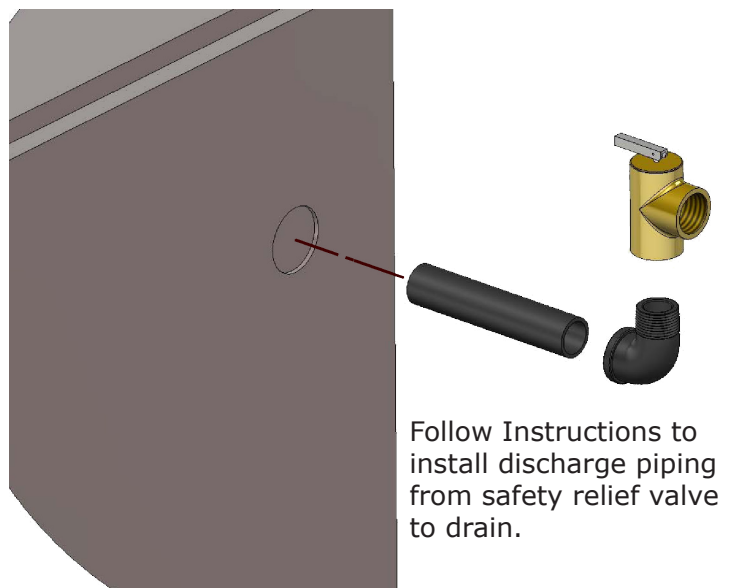

**Figure 7 - Bypass Piping Arrangement Diagram**

- > **LOW DESIGN WATER TEMPERATURE SYSTEMS**
- > **LARGE WATER CONTENT SYSTEMS**
- > **PIPING ARRANGED FOR "POWER PURGING" AIR OUT OF THE SYSTEM PIPING, REFER TO THIS MANUAL'S SECTION ON "FILLING THE SYSTEM WITH WATER" OPTION #1**

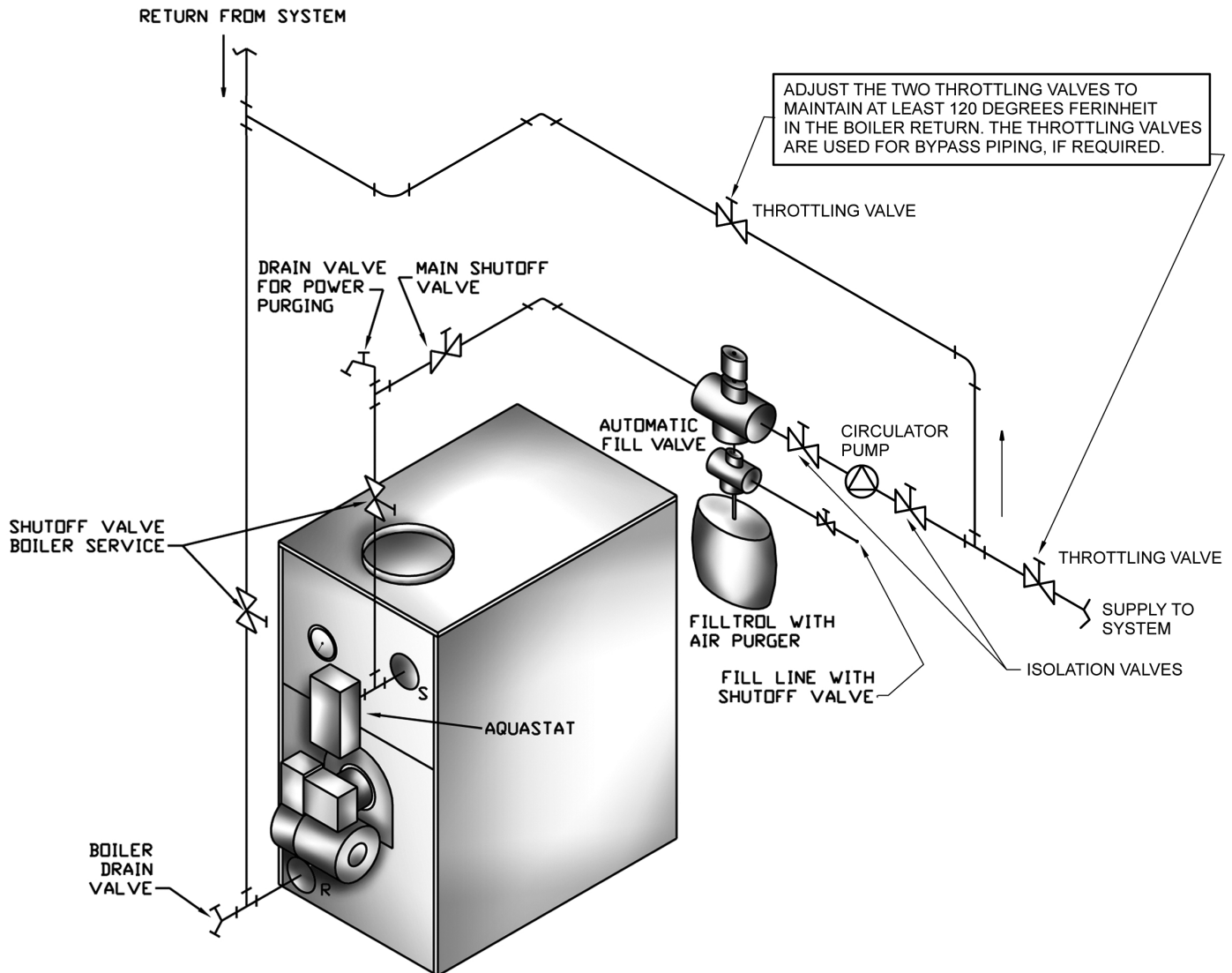

Figure 8 - System Piping Arrangement Zoning With Zone Valves

- > CIRCULATOR ON SUPPLY PIPING PUMPS AWAY FROM EXPANSION TANK

NOTE: CIRCULATOR CAN ALSO BE INSTALLED ON RETURN PIPING.

- > PIPING ARRANGED FOR "POWER PURGING" AIR OUT OF SYSTEM PIPING, REFER TO THIS MANUAL'S SECTION ON "FILLING THE SYSTEM WITH WATER" OPTION #1

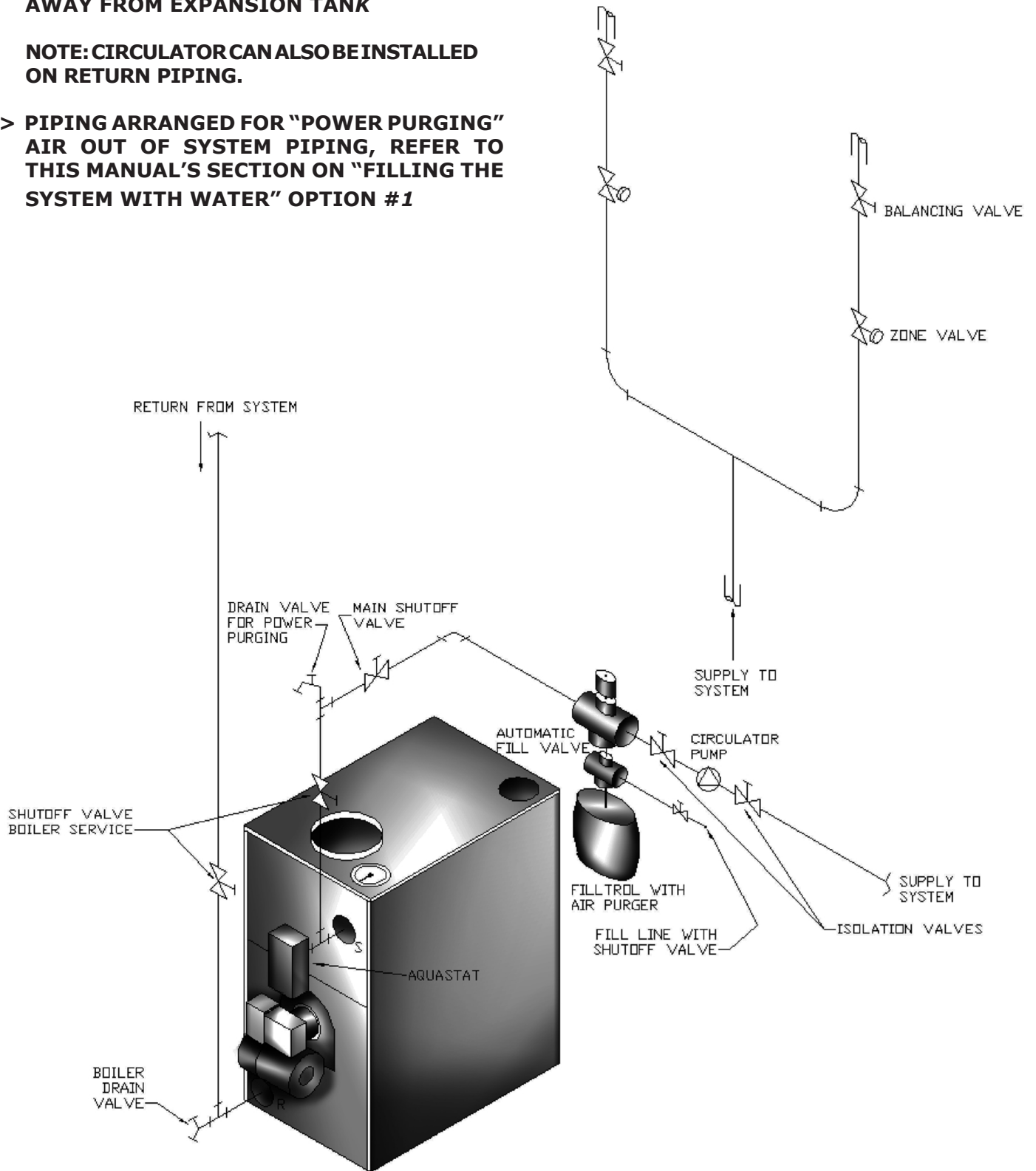

Figure 9 - System Piping Arrangement Zoning With Circulators

- > CIRCULATOR ON SUPPLY PIPING PUMPS AWAY FROM EXPANSION TANK
- > PIPING ARRANGED FOR "POWER PURGING" AIR OUT OF SYSTEM PIPING, REFER TO THIS MANUAL'S SECTION ON "FILLING THE SYSTEM WITH WATER" OPTION #1

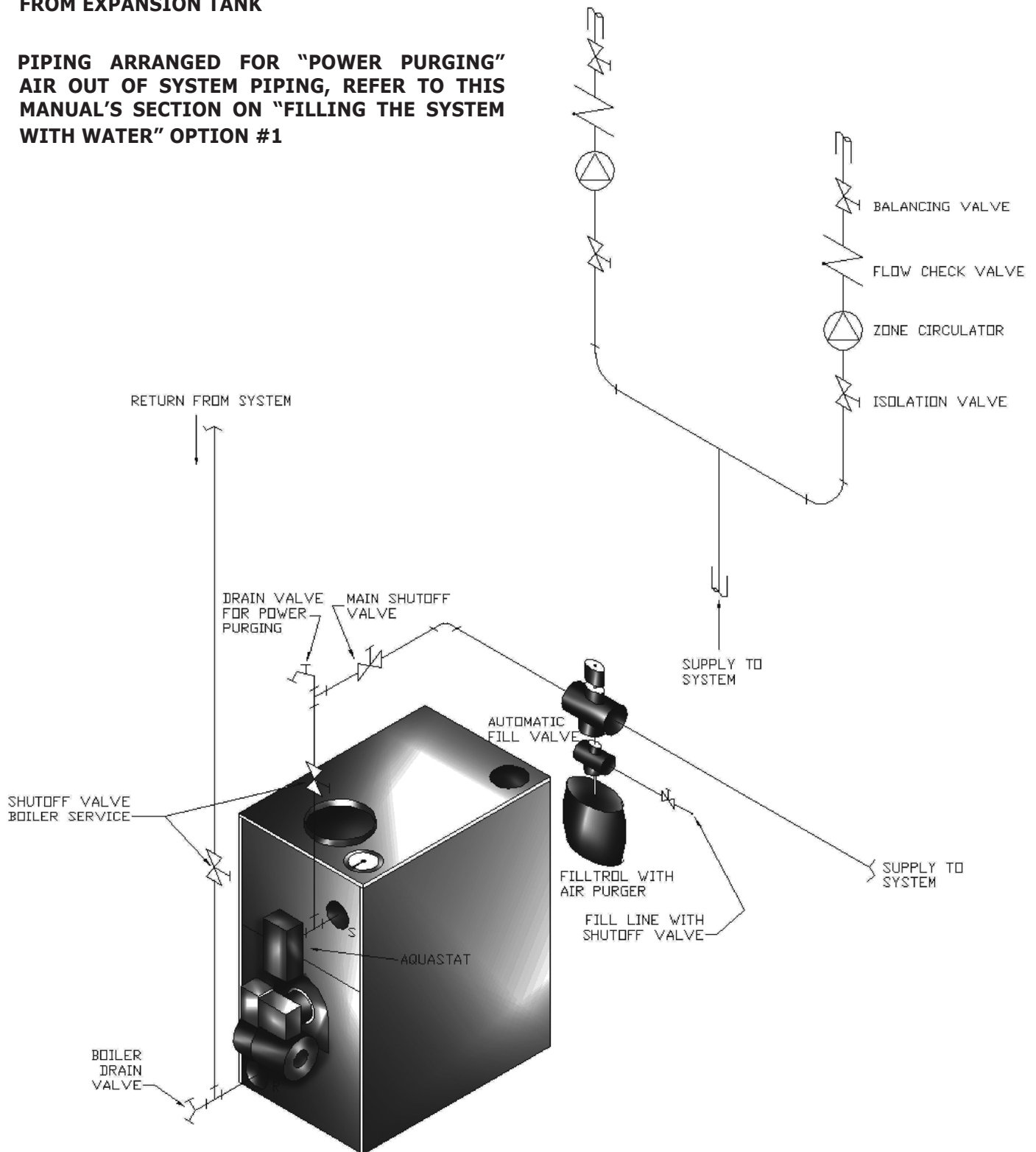
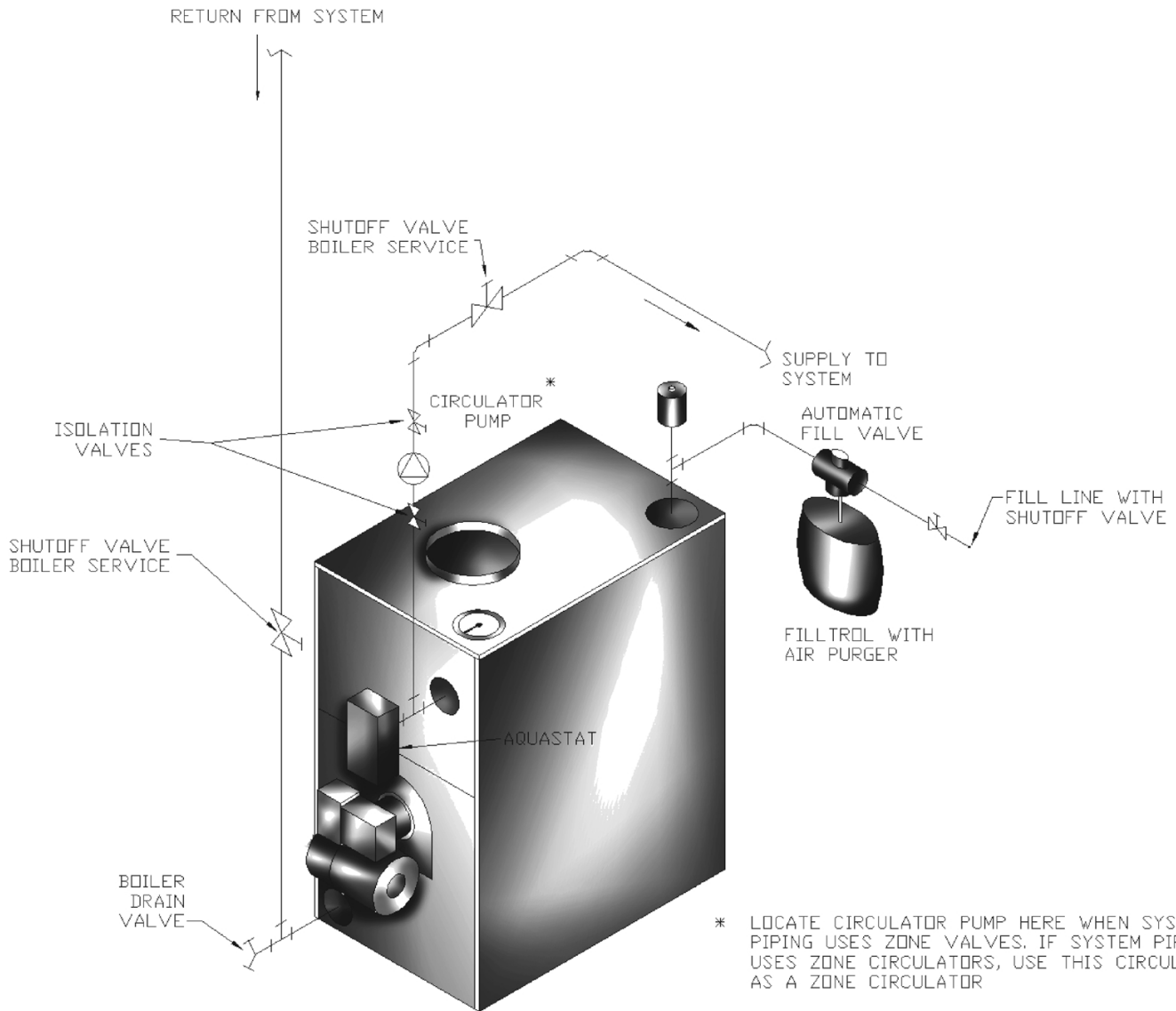

Figure 10 - System Piping Arrangement Alternate Near Boiler Piping

- > DIAPHRAGM EXPANSION TANK MOUNTED OFF THE BOILER
- > PER THIS MANUAL, USE OPTION #2 IN "FILLING THE SYSTEM WITH WATER"
- > CIRCULATOR ON SUPPLY PIPING PUMPS AWAY FROM EXPANSION TANK
- > THIS PIPING ARRANGEMENT CAN BE USED WITH ZONE VALVES OR ZONE CIRCULATORS



## SYSTEM PIPING

### Tankless Coil Piping Arrangement

Boilers may be factory **packaged with tankless heater coil** see figure below. Coil provides instantaneous heating of water for domestic use if proper burner and water supply line controls are used. Tankless coils are meant to provide domestic hot water for intermittent draws, not continuous flow.

#### NOTICE

Do not use tankless coil if your water is excessively hard with lime or other deposits which will accumulate inside the coil.

When using tankless coil, boiler is configured so Honeywell L7248 operates with Honeywell L4006 low limit mounted on well installed in tankless heater. Mount factory wired low limit on well.

Tempering valve (mixing valve) is required as shown below. Flow restrictor may be required on tankless coil inlet piping so that flow rates are matched to boiler heat input (see table).

#### ⚠ DANGER

Water temperatures exceeding 125°F will cause severe burns instantly or death by scalding.

Boiler Model	Burner Input Rate (gph)	Input (MBH)	Tankless Rating (gpm)‡
COWB3-3-.65	0.65	91	2.90
COWB3-3-.75	0.75	105	3.00
COWB3-3-1.00	1.00	140	3.25
COWB3-4-.90	0.90	126	3.15
COWB3-4-1.25	1.25	175	3.50
COWB3-4-1.50	1.50	210	3.75
COWB3-5-1.20	1.20	168	3.45
COWB3-5-1.75	1.75	245	4.00

‡ Gallons of water per minute heated from 40°F to 140°F with 200°F boiler water temperature, intermittent draw

**Figure 11 - Tankless Coil Piping Arrangement**

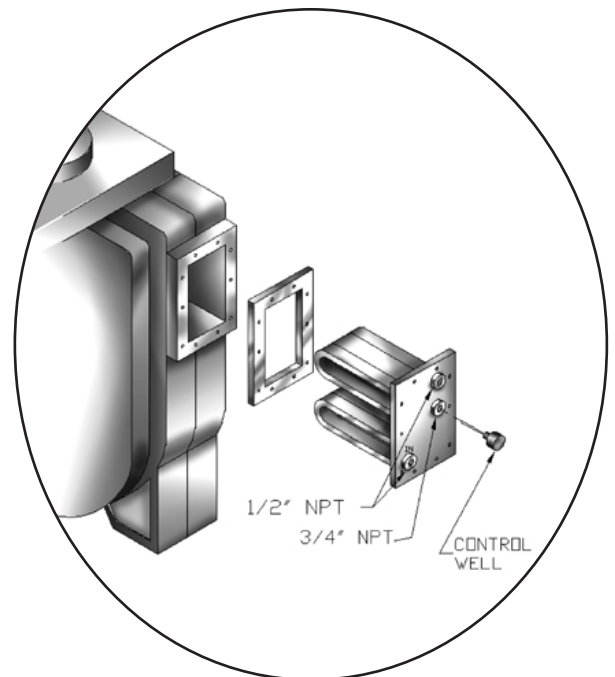
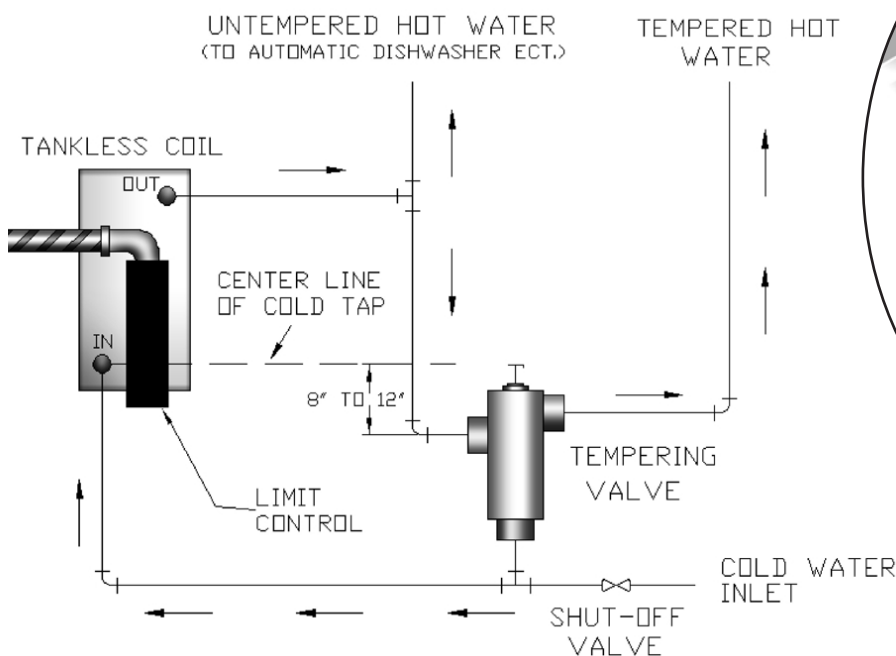

## SYSTEM PIPING ARRANGEMENT

**Antifreeze added to boilers** must be nontoxic, and must be of type specifically intended for use in closed hydronic heating systems. Under no circumstances should automotive antifreeze be used. Antifreeze used in any boiler may reduce capacity by 10% or more and increase fuel consumption. Tankless coil performance will fall as concentration of antifreeze is increased. Refer to boiler and piping water volumes tables.

<b>BOILER WATER VOLUMES</b>	
Number of Boiler Section	Total Volume (Gallons)
3	9.6
4	11.6
5	13.7

<b>PIPING WATER VOLUMES</b>		
PIPE SIZE	COPPER PIPE FACTOR	STEEL PIPE FACTOR
½"	82.5	63.5
¾"	40.0	36.0
1"	23.3	22.2
1 ¼"	15.3	12.8
1 ½"	10.8	9.5
2"	6.2	5.8

Divide total length of piping in feet by appropriate factor in table to determine volume in gallons.

## CHIMNEY AND CHIMNEY CONNECTIONS

For oil fired boilers for connections to vents or chimneys, vent installations shall be in accordance with requirements of authority having jurisdiction, or in the absence of such requirements: United States. NFPA 31: Installation of Oil Burning Equipment.

### NOTICE

Fresh air (ventilation) is important to proper venting. Ventilation and venting are two parts of the same system. Inadequate ventilation will result in inadequate venting. Always be sure to have enough ventilation to support proper venting.

Inspect chimney. Verify construction in accordance with requirements of authority having jurisdiction, or in the absence of such requirements: United States. ANSI/NFPA 211: National Standard for Chimneys, Fireplaces, Vents and Solid Fuel Burning Appliances.

### ⚠ WARNING

Fire Hazard. Maintain minimum vent pipe clearance of 18" from surface of vent to wood and other combustible materials. Failure to comply may result in death or serious injury.

#### Chimney Connector And Draft Regulator

- Venting the boiler requires 6" diameter chimney connector pipe and use of manufacturer provided draft regulator.
- Regulator, when properly installed, automatically controls the draft.
- Install in horizontal section of pipe, may also be installed in angled or vertical section of pipe.
- Verify "top" of regulator is at the top and short pipe section which holds the vane is horizontal.
- Even though locating draft regulator close to chimney reduces noise, **install draft regulator as close as practicable to the boiler.**
- Install chimney connector, start at boiler with vertical pipe, elbow, then install draft regulator horizontally.
- When regulator is in place, start at chimney and work back to the regulator.
- Join the two sections with draw-band.
- Horizontal pipe must slope up toward the chimney at least 1/4 inch per linear foot of venting.
- Chimney connector must not leak and must be firmly supported.
- Join each section with at least two sheet metal screws. Support every second section with a stovepipe wire.
- Install Vent Safety Switch. Follow instructions included with kit. See Figure 12.

#### RECOMMENDED MINIMUM CHIMNEY SIZES

FIRING RATE (gph)	CHIMNEY HEIGHT (ft)	NOMINAL CHIMNEY	ROUND LINER INSIDE	SQUARE LINER INSIDE
0.60 1.30	15	8" x 8"	6"	6 3/4" x 6 3/4"
1.31 1.80	15	8" x 8"	7"	6 3/4" x 6 3/4"
1.81 1.75	20	8" x 8"	8"	6 3/4" x 6 3/4"

For elevations above 2,000 feet above sea level, add 3 feet to the chimney heights.

#### **Sidewall Venting With Listed Power Venter**

- This boiler is not approved for direct sidewall horizontal venting.
- **In the U.S. :** Per section E.11 of NFPA 31-2011 *Standard for the Installation of Oil Burning Equipment*, a listed power venter providing mechanical draft may be used when approved by the Authority having jurisdiction. Select the listed power venter to match the BTU per hour input of the boiler being vented. Follow all manufacturer's installation and operating instructions for venting and termination included with the power venter.



## TYPICAL CHIMNEY CONNECTION

Figure 12 -Typical Chimney Connection

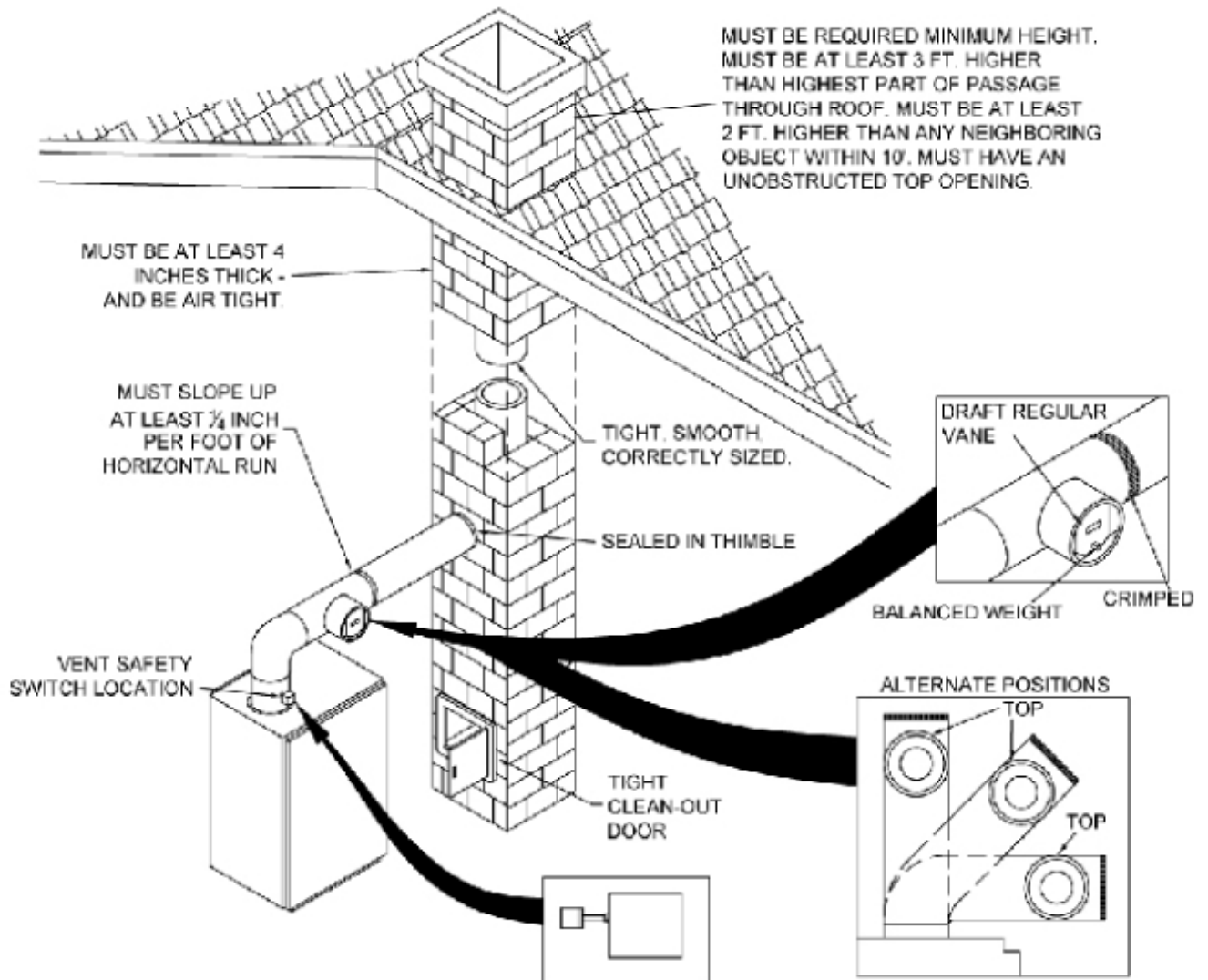

### **WARNING**

Electrical shock hazard. Turn OFF electrical power supply at service panel before making electrical connections. Failure to do so could result in death or serious injury.

#### **Thermostat**

Install 24 Volt thermostat (not provided) in proper location. Location of thermostat has effect on boiler system operation. Follow instructions included with thermostat.

#### **Electric Power Supply**

Connect boiler to electrical supply in accordance with requirements of authority having jurisdiction, or in the absence of such requirements: United States. NFPA70: National Electrical Code.

Connect 115 volt electrical supply to L1 and L2 terminals on limit and two thermostat wires to T and T terminals on same limit. See wiring diagram page 28.

Run separate circuit from separate over current protection device in your electrical service entrance panel. Minimum 15 ampere circuit. Locate shutoff switch at boiler. Turn off during any maintenance.

Permanently ground boiler. Run 14 gauge or heavier copper wire from boiler to grounded connection in service panel or properly driven and electrically grounded ground rod.

## FILLING THE BOILER

### How A Hot Water System Operates

Entire heating system (boiler, piping, and radiation units) is filled with water. As water in the boiler is heated, it is circulated from top of boiler through supply main to radiation units. Cooler water in radiation units flows back through return piping through return main into the boiler. This arrangement provides positive and rapid response to the thermostat.

### Filling The System With Water

**OPTION #1** This method utilizes boiler piping as shown in figure on page 6.

- A. **Close** main shutoff valve, isolation valves, and zone valves (if applicable). If bypass piping is installed, also close two throttling valves. Leave boiler service shutoff valve (if installed) and balancing valves to each heating zone **fully open**.
- B. **Open** following valves in order: drain valve for power purging, isolating valves before and after boiler circulator (if applicable), both throttling valves (if applicable), and then open fill line shutoff valve. Water will fill bypass piping and push air through piping and out power purging drain valve. When power purging drain valve runs air free, close bypass piping throttling valve (leaving throttling valve to supply piping fully open).
- C. Next, **open** isolation valve (or zone valve) to first zone. Water will fill piping and push any air out power purging drain valve. When power purging drain valve runs air free, close isolation valve or zone valve). Repeat this procedure for remaining heating zones.
- D. Once all zones are filled with water and purged of air, **close** power purging drain valve and fill line shut off valve, **open** main shutoff valve, and **adjust** throttling valves and balancing valves as required.

### OPTION #2

- Close air vents on all radiation units.
- Open valves to radiation units. Verify boiler drain valve, expansion tank drain cock, and air bleed screw on expansion tank drain fitting are closed.
- Open fill valve on piping to expansion tank.
- Open water inlet to boiler and leave it open.
- Open air vent on lowest radiation unit.
- When all air has escaped and water starts to flow from vent, close it.
- Go to next radiation unit, and repeat this process until finishing with highest radiation unit.
- If heating system has automatic vents, this manual venting is unnecessary but it will speed up proper filling of the system.

If system is a closed expansion tank system, automatic fill valve is needed. Leave automatic fill valve open to refill system automatically as needed.

Note initial fill pressure on boiler's temperature / pressure gauge, which should be 10-15 psig. Any lowering of pressure from its initial fill pressure indicates loss of water due to leakage. Automatic fill valve should then compensate for this water pressure loss. If it does not, manually open this valve to refill system until needle is again pointing to same pressure reading. Instructions are packaged with valve.

## OPERATING THE BOILER

**Start:** Fill entire system with water. Vent all air from system following section for Filling The Boiler.

### Fuel Units And Oil Lines:

- Install oil line(s) to oil burner.
- Recommend using heavy wall copper tubing and flared fittings, not compression fittings.
- All connections and joints must be absolutely airtight. Use an appropriate non-hardening thread sealing compound on the threaded connections, not Teflon tape.
- See fuel unit data sheet furnished with the burner for sizing, lift, and length of tubing recommendations.

Oil burner is equipped with single stage fuel unit with bypass plug removed for single pipe installation. Satisfactory where fuel supply is on same level as or above burner permitting gravity flow of oil. Per NFPA 31 requirements, never exceed 3 psig pressure to inlet side of fuel unit.

When necessary to lift oil to burner, two pipe installation is required. Run return line between fuel unit and oil supply. When two pipe installation is used, bypass plug (furnished with burner) must be installed in fuel unit. Refer to fuel unit instructions furnished with burner for specific instructions on installing bypass plug. Do not exceed fuel unit manufacturer's recommendations for running vacuum.

### NOTICE

If lift exceeds 14 feet for Beckett or Carlin burners or 11 feet for Riello burners, two stage fuel unit is required with return line.

Install oil filter of adequate size inside building between tank shutoff valve and oil burner. For ease of servicing,

locate shutoff valve and filter near oil burner.

### Air Supply For Combustion:

- Do not install boiler in rooms with insufficient air, unless corrective steps are taken.
- It may be necessary to install windows or cut holes in a door to rooms used for supply air to obtain sufficient combustion air and prevent less than atmospheric air pressure in that room.
- If there is a lack of combustion air, burner flame will be dark orange and formation of soot will occur in heating unit.
- In buildings of conventional frame, brick, or stone construction that do not have utility rooms, basement windows, or stair doors, air infiltration is normally adequate to provide enough air for combustion and for operation of barometric draft control.
- Room used for supplying combustion air should be isolated from any area served by exhaust fans.
- Refer back to the section on Fresh Air For Combustion for additional sizing guidelines.

**Draft Regulators:** Barometric draft regulator is required for controlling draft through boiler. Mount barometric draft regulator in chimney connector. Refer back to section on "Chimney And Chimney Connections". Once draft regulator is installed, use draft gauge to adjust to proper opening:

- A. Combustion chamber over fire draft will be approximately  $-0.01''$  WC to  $-0.02''$  WC.
- B. Stack draft will be approximately  $-0.02''$  WC. to  $-0.04''$  WC.
- C. Larger installation, greater draft will be required in stack to obtain desired over fire draft.

## OPERATING THE BOILER

**Nozzles And Electrodes:** Use proper size, spray angle, and spray pattern nozzle. Refer to recommended nozzle selection charts.

To install nozzle, remove nozzle line electrode assembly, if necessary remove retention ring assembly, and install and tighten nozzle. Take care not to damage electrode insulators or bend electrode tips.

After installing nozzle, reassemble nozzle line electrode assembly and set electrode tip spacing.

Depending on burner type, electrode tip spacing may need to be set prior to reassembling nozzle line electrode assembly.

Refer to following pages for setting electrode tip spacing.

**Final Burner Adjustments:** Final burner adjustments must be made using combustion test instruments. Refer to "Burner Settings". Set burner accordingly.

- Check draft over fire to verify it is between -0.01" WC and -0.02" WC, adjust draft as necessary.
- After operating 10 minutes to warm up boiler, use combustion test equipment to take smoke reading in flue pipe between boiler and draft regulator.
- Smoke reading should be zero to trace (Shell Bacharach Scale).
- A new boiler requires more than 10 minutes to burn clean due to oil film on new heat exchanger.
- If smoke reading is zero, gradually close burner's air adjustment to obtain smoke reading showing trace smoke reading. Once smoke reading is trace, measure CO<sub>2</sub> and as insurance margin increase air to sufficiently reduce CO<sub>2</sub> by ½% to 1%.

If clean fire cannot be obtained, it is necessary to verify burner head and electrode alignment. Proper electrode alignment figures are presented on following pages. If fire continues to be smoky, replace nozzle with correct replacement.

Once burner is completely adjusted, burner should be started and stopped several times to assure good operation with no fluttering or rumbling. Verify there are no oil leaks and record nozzle size, oil pressure, combustion readings, and air settings on tag or label attached to burner or boiler.

**Oil Burner Maintenance:** Perform following preventative maintenance annually, preferably prior to heating season.

1. **Fuel Filter** Replace to prevent contaminated fuel from reaching nozzle. Partially blocked fuel filter can cause premature failure of fuel pump.
2. **Fuel Pump Unit** Replace pump screen and clean pump unit to maintain fuel delivery to nozzle.
3. **Ignition Electrodes** Clean and adjust per manufacturer's recommendations, to maintain reliable ignition of oil.
4. **Nozzle** Replace to maintain safe and reliable combustion efficiency. Replace with nozzle as required in charts located in this manual.
5. **Fan and Blower Housing** Must be kept clean, free of dirt, lint and oil to maintain proper amount of air fuel requires to burn.
6. **Check Final Burner Adjustments.**

If any component parts must be replaced, always use parts recommended by burner manufacturer.

Figure 13 - Burner Adjustments and Settings

BECKETT AFG BURNER ELECTRODE ADJUSTMENTS VARIABLE (V1) HEADS

BOILER MODEL	DIMENSION "N" (electrode to nozzle)	DIMENSION "H" (head to nozzle)
5EW	1/16"	7/32" - 9/32"

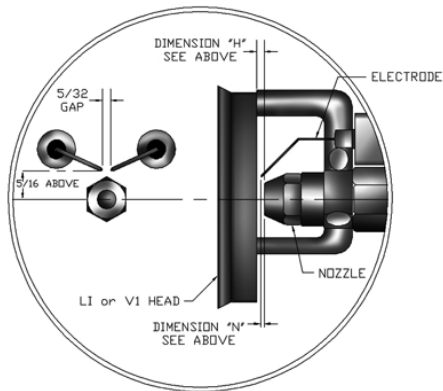

BECKETT AFG VARIABLE (V1) HEAD ADJUSTMENTS AND SETTINGS

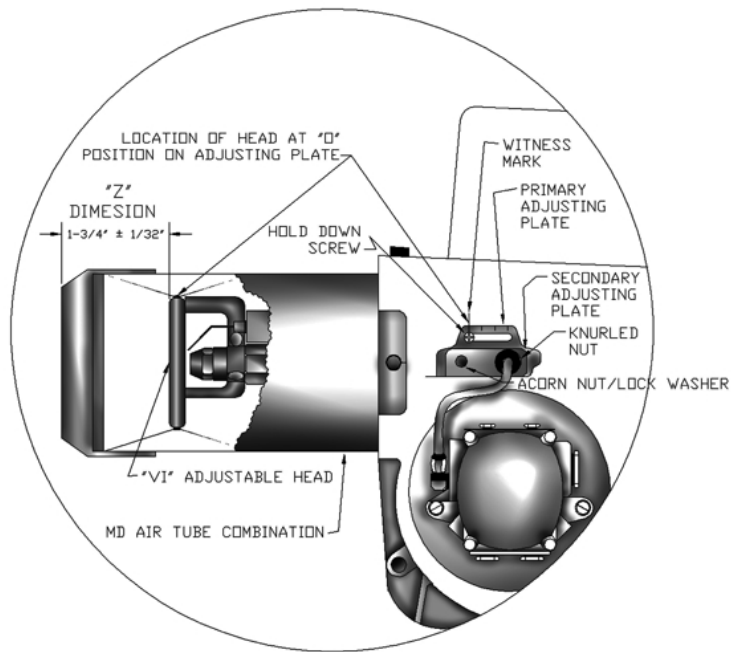

BECKETT AFG BURNER ELECTRODE ADJUSTMENTS F-HEADS

BURNER F-HEAD MODEL	DIMENSION "N" (HEAD TO NOZZLE)
F0 THRU F31	1/16"

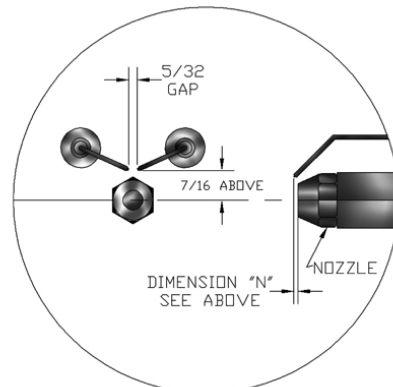

## CHECKING AND ADJUSTING CONTROLS

### ⚠ WARNING

Burn, scald hazard. Do not attempt to start the burner when excess oil has accumulated, when the unit is full of vapor, or when the combustion chamber is very hot.

### NOTICE

You or your installer must follow these instructions carefully.

**Adjust Operating Controls:** Use following settings for first adjustment:

#### High Limit:

Baseboard and Convectors 200°F  
Standing Radiators 180°F

**Low Limit** (when used) 140° (increase if hotter domestic water is required, low limit set point must be at least 20°F less than high limit set point)

When low limit is used, set ELL parameter on L7248 Honeywell Control to ON. Boilers factory equipped with tankless coils, are already set to ON.

**Adjust Thermostat Heat Anticipator To: 0.2 Amps**

#### Check Thermostat Operation:

Follow instructions included with your thermostat. Locate thermostat five feet above the floor on inside wall. Locate thermostat to sense average room temperature, avoid the following:

THERMOSTAT LOCATIONS TO AVOID		
DEAD SPOTS	HOT SPOTS	COLD SPOTS
Behind doors	Concealed pipes	Concealed pipes or ducts
	Fireplace	
	TV sets	Stairwells drafts
Corners & alcoves	Radios	Doors drafts
	Lamps	Unheated room on other side of wall
	Direct sunlight	
	Kitchens	

When temperature on thermostat is set above indicated thermostat temperature, boiler's burner should start. Verify that when room temperature reaches selected temperature setting, thermostat should turn boiler's burner off, and once room temperature falls few degrees boiler starts operating again.

**Do not start burner unless all cleanout doors are secured in place.**

## MAINTENANCE

**Annually:** Recommend flue passages, combustion chamber area (target wall, fire door insulation, durablanket), burner adjustment, control operation, and boiler seals (fire door gasket or silicone seal, cast iron sectional seals, flue collector) be checked once each year by trained Service Technician.

**Before The Start Of Each Heating Season** (or when system has been shut down for extended periods of time) recheck whole system for water, oil, and vent piping leaks. Replace or patch any leaks or faulty seals.

**Vent Pipe:** Visually inspect entire venting system once a month for any signs of leakage, deterioration, or soot build up. If vent pipe shows any signs of leaking or deterioration, replace it immediately. If it shows any signs of soot build up, clean vent pipe and have burner settings and combustion checked by trained Service Technician.

**Safety Relief Valve:** Valve should open automatically when system pressure exceeds pressure rating (usually 30 psi) of safety relief valve. Should valve ever fail to open under this condition, shut down the system. Drain system until system pressure is reduced below safety relief valve pressure rating. Contact Service Technician to replace the valve and inspect heating system to determine cause, may indicate equipment malfunction. Safety relief valve should be tested monthly during heating season. Prior to testing, make certain discharge pipe is properly connected to valve outlet and arranged so as to contain and safely dispose of boiler discharge. Hold trip lever fully open for at least five seconds in order to flush free any sediment that may lodge on valve seat. Permit valve to snap shut. Refer to valve manufacturer's instructions packaged for more details.

**Conventional Expansion Tank:** Tank may become water logged or may receive excess air. Frequent automatic opening of safety relief valve indicates water logging. High boiler temperature accompanied by unusually low radiation unit temperature (and "knocking" noises) indicates excess air in the tank. To correct either condition, close valve between boiler and tank. Drain tank until empty. Check all tank plugs and fittings, tighten as necessary. Open valve between boiler and tank. Water will rise to normal height in tank if system has automatic fill valve, otherwise manually refill system.

**Diaphragm Expansion Tank:** Tank may become water logged. Frequent automatic opening of safety relief valve indicates water logging. High boiler temperature accompanied by unusually low radiation unit temperature (and "knocking" noises) indicates excess air in the tank. To correct this condition, replace diaphragm expansion tank.

**Water System:** If system is to remain out of service during freezing weather, drain it completely (water left in system may freeze and will crack pipes and/or boiler).

**Tankless Coil (Or Cover Plate) Gasket:** Gasket should be checked at least twice year for leakage, replace if necessary. If gasket is replaced, make sure that when coil plate (or cover plate) is reattached, ten nuts are torqued in alternating pattern to insure equal force is applied to entire gasket creating good seal. Nuts should be torqued so gasket does not squeeze out from behind the plate.

**Oil Burner:** Oil burner maintenance is listed in this manual under "Operating The Boiler".

**Never burn garbage or paper in the unit, never leave combustible material around it.**



## OIL BOILER / BURNER CLEANING INSTRUCTIONS

### Oil Boiler Cleaning:

1. Shut off all electrical power to boiler / burner and shut off fuel oil supply.
2. Remove vent pipe from top of boiler. Inspect pipe and chimney for signs of corrosion and deterioration. Clean out base of chimney. If vent pipe shows any signs of corrosion or deterioration, replace it immediately. If chimney damage or deterioration is discovered, contact a service technician.
3. Remove top jacket panel screws (5), brass wing nuts (2) holding flue collector top, and flue collector top. Inspect gasket on underside of flue collector and replace as necessary.
4. Before beginning to clean flue passageways, insure combustion chamber blanket is covered. If blanket is not covered prior to cleaning, replace blanket once cleaning is completed.
5. With access to flue passageways, remove soot from fireside surfaces by brushing diagonally through flue passages (see drawing below). Brushing can be made easier by cutting end of flue brush off and inserting it into drill. When brushing, take care to not damage target wall with flue brush.
6. Carefully vacuum soot accumulations from combustion chamber area, take care to not damage any of refractory or blanket insulation. To gain access to combustion chamber first check that shut off valve on fuel oil line is closed and disconnect fuel oil line. Open swing door by removing whiz lock nut holding door shut.
7. Inspect target wall, fire door refractory, and combustion chamber blanket (when included) for cracking and deterioration. If there are signs of cracking or deterioration, replace refractory or blanket before reassembling burner / front plate.
8. Inspect door's braided gasket for wear and damage. Replace when necessary with braided gasket of same material and size.
9. Inspect and clean oil burner.

### NOTICE

Important operating and maintenance requirements:

- Keep your boiler and the area around it clean
- Never burn refuse or any material other than specified fuel in your boiler

**Figure 14 - Brush Diagonally Through Flue Passages**



## OIL BURNER CLEANING

**These are general instructions for cleaning an oil burner. For specifics, consult burner manufacturer's instructions.**

### **WARNING**

Electrical shock hazard. Turn OFF electrical power supply at service panel before making electrical connections. Failure to do so could result in death or serious injury.

1. Verify all electrical power to boiler / burner and fuel supply to burner are shut off.
2. With swing door open, clean any soot accumulations from end of burner and if applicable burner head.
3. Remove burner drawer assembly, clean electrodes and then reset electrode spark gap per manufacturer's recommendations.
4. Replace oil nozzle with same size and type recommended for use on this boiler.
5. Install burner drawer assembly make sure head location (and size if applicable) are per manufacturer's recommendations. If burner being used has damaged head, replace head with same head recommended for use on this boiler.
6. Inspect and clean oil burner blower wheel.
7. Remove oil pump cover and clean / replace pump screen. Carefully reassemble insuring pump cover creates proper seal.
8. Securely fasten swing door shut.
9. Replace fuel filter (if applicable).
10. Connect electrical and fuel supplies.
11. Fire burner, check for proper combustion using combustion test equipment and making adjustments as necessary.
12. Insure all safety controls and operating controls are functioning properly.

## SERVICE HINTS

**You may avoid inconvenience and service calls by checking these points before you call for service:**

<b>IF YOUR SYSTEM IS NOT HEATING OR NOT GIVING ENOUGH HEAT . . .</b>	
<b><i>POSSIBLE CAUSE</i></b>	<b><i>WHAT TO DO</i></b>
Thermostat is not set correctly	Reset thermostat
Burner is not operating properly	Check flame. If it is yellow, the burner is not getting enough air. Or, if flame is blue and noisy and seems to lift off the burner, the burner is getting too much air. Contact your service technician.
No electric power to boiler	Check over-current protection. Check to be sure electric power supply circuit is "ON".
Controls out of adjustment	Reset according to instructions.
Radiators not heating	Open radiator vents to excess air. Check flow control valve (if used). It may be in closed position.
Circulating pump not running	Check over-current protection. Check relay operation.
Poor electrical contact	Check all control terminals and wire joints.
Chimney flue is blocked	Have the chimney professionally cleaned.
Circulator running when boiler water temperature is below low limit setpoint (tankless coil equipped boilers only)	Confirm ELL parameter on L7248 control is set to ON. Refer to Honeywell L7248L instructions furnished with boiler.
<b>RELIEF VALVE LEAKING . . .</b>	
<b><i>POSSIBLE CAUSE</i></b>	<b><i>WHAT TO DO</i></b>
Corrosion and/or deposits on seat.	Open valve manually. Allow water to run and clear valve seat.
Water logged expansion tank	Drain tank, see instructions.
<b><i>HAVE YOUR SERVICE TECHNICIAN CHECK ANY PROBLEM YOU ARE UNABLE TO CORRECT.</i></b>	

Figure 16 - Boiler Honeywell L7248L Control

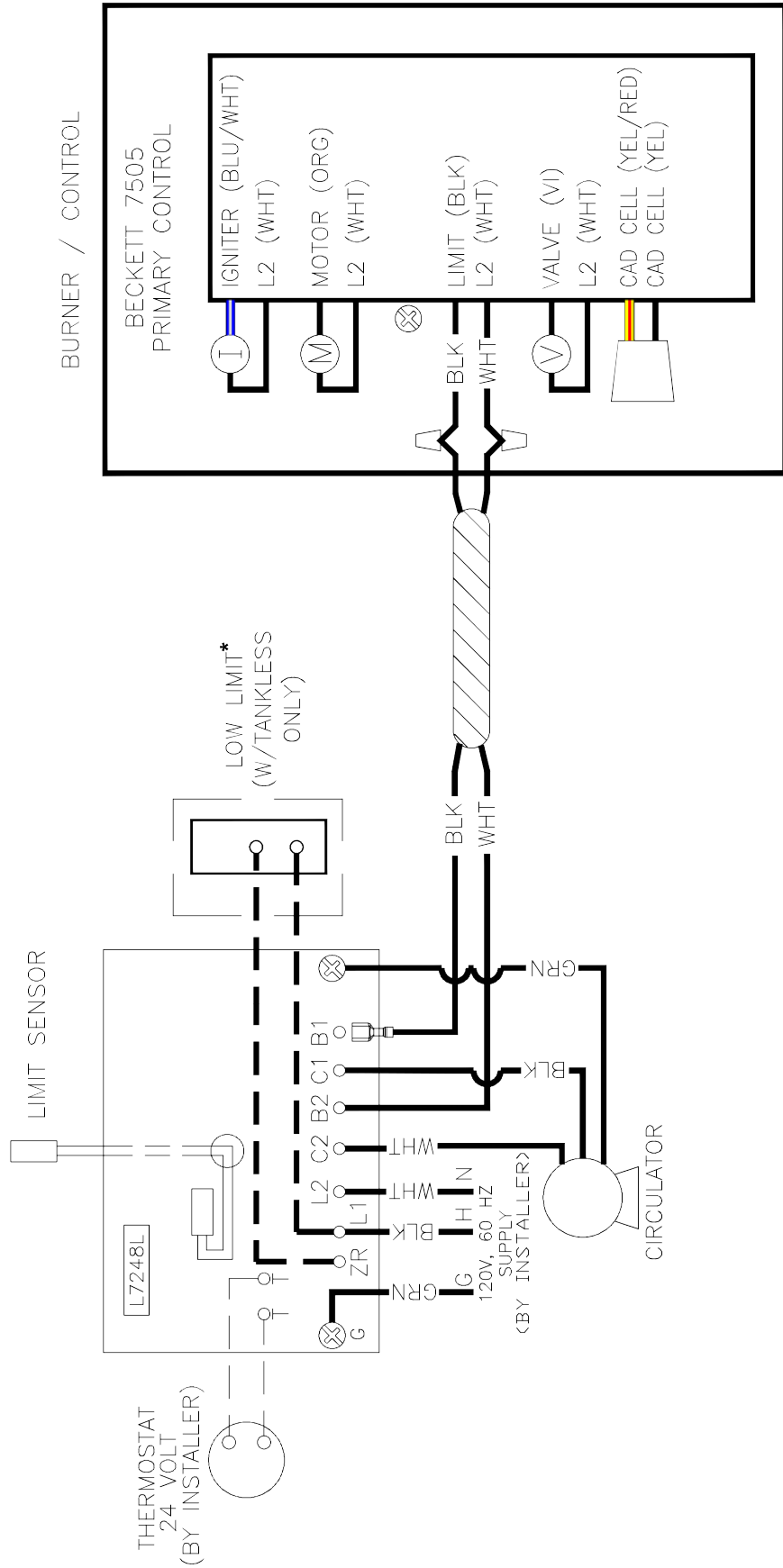

**\* When Low Limit Is Used, Set ELL Parameter On L7248 Honeywell Control To On. Boilers Factory Equipped With Tankless Coil Are Factory Set To On.**

Figure 17 - Honeywell L7248L Control With Riello F5/F10 Burner

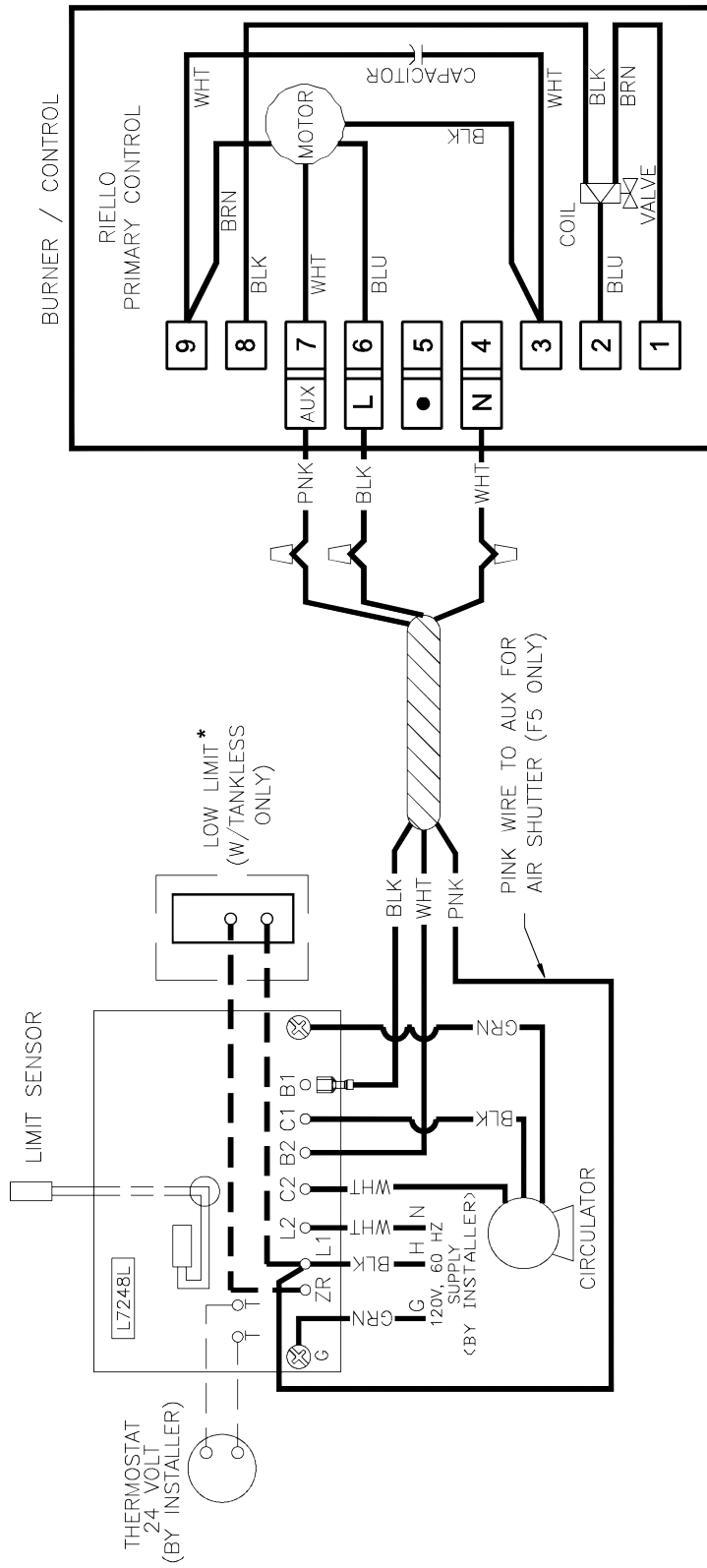

**\* When Low Limit Is Used, Set ELL Parameter On L7248 Honeywell Control To On. Boilers Factory Equipped With Tankless Coil Are Factory Set To On.**

# ELECTRICAL WIRING

**Figure 18 - Honeywell L7248L Control Wiring with Zone Pumps and Argo ARM Switching Relay (With Tankless coil Shown)**

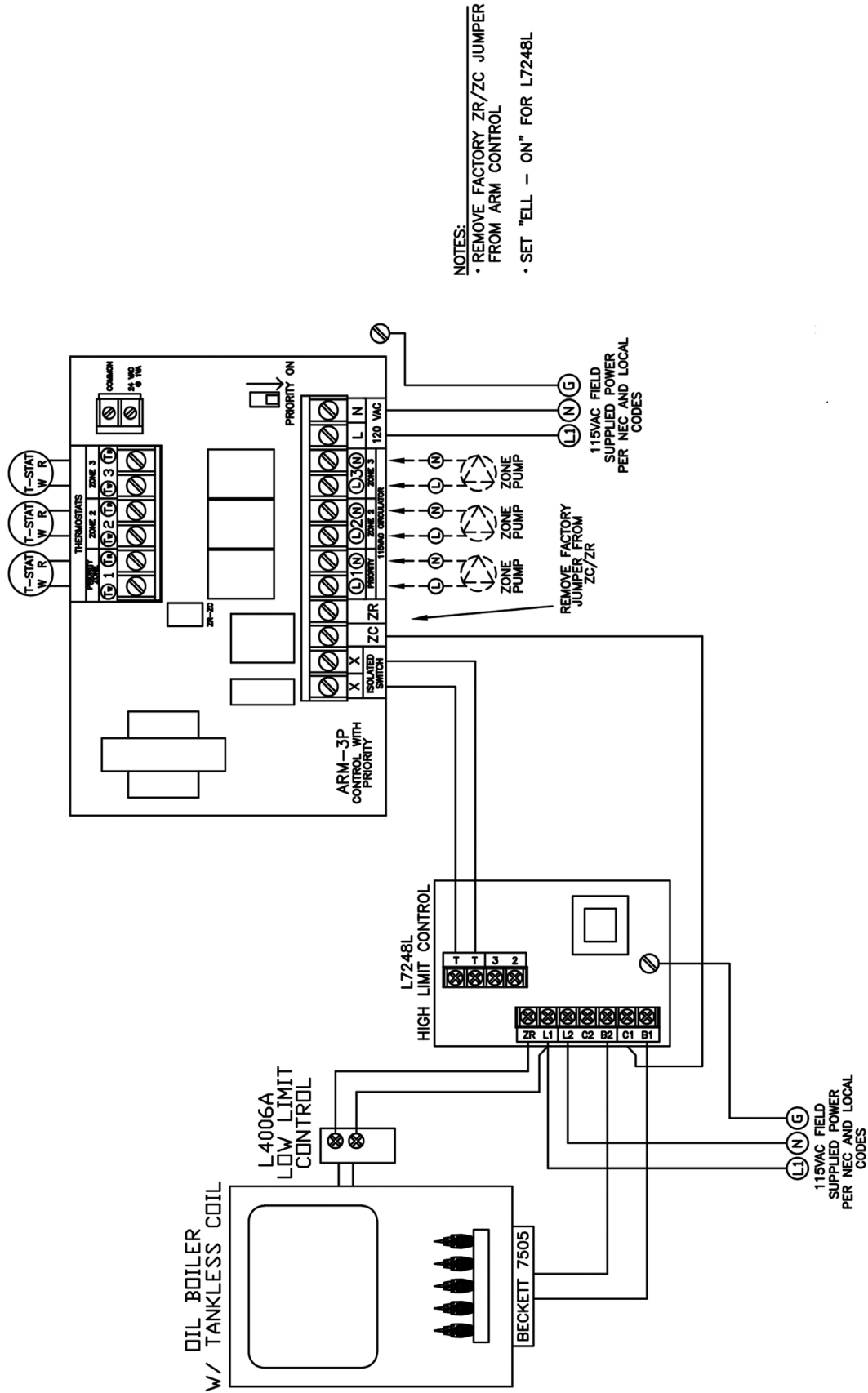

## EQUIPMENT AND OPTIONAL ACCESSORIES

### **MAIN AIR VENT: for down flow systems or diaphragm type expansion tanks (not provided)**

Before system is filled with water, there is air in pipes and radiation units. Some air will be trapped as system is filled. It is possible to eliminate most of this air through air vents on radiation units. Main air vent will speed and simplify this process. Install main air vent on highest point in supply main when all radiation is below top of boiler.

### **AUTOMATIC FILL VALVE (not provided)**

For safe, efficient operation, hot water system must be filled with water. Adding new water, when needed can be done manually (by use of hand valve in water supply line). This requires regular attention to system's needs. Automatic fill valve or pressure reducing valve accomplishes this without attention. Install in supply line on hot water boilers only. Valve operates through water pressure differentials. It does not require electrical connection.

### **BURNER SOLENOID VALVE (provided)**

Beckett and Carlin oil burner's use standard solenoid valve. Upon burner shut down, standard solenoid valve stops flow of oil to nozzle. Without solenoid valve, oil pump continues to pump oil to burner nozzle until burner motor winds down below pumps cutoff speed. Riello oil burner has delay solenoid valve. Delay solenoid valve provides same shut down action as standard solenoid valve, plus on burner start up delay solenoid valve remains closed for additional 15 seconds. Allows burner fan motor to pre-purge combustion chamber and oil pump to bring supply oil pressure up to its set point helping to provide clean light off.

### **LIMIT CONTROL (provided) Refer to manufacturer instructions provided with limit control**

Water temperature limit control in limit is adjustable and may be set: as low as 140°F so long as return water temperatures to boiler are no less than 120°F, or as high as 220°F so long as boiler and heating system have adequate circulation to remove heat from boiler otherwise steam may be created in boiler. Refer back to "System Piping" section for more information.

### **DRAIN VALVE (provided)**

Drain valve is manually operated valve provides means of draining all water from boiler and heating system. It should be installed in reducing tee where return line enters boiler.

### **CIRCULATOR (provided)**

Every forced hot water system requires circulator. Separate circulator or zone valve is required for each zone, if there are two or more zones. Circulator must have capacity to provide circulation required by heating system. Circulator should be connected to supply main and must be wired into boiler's electrical system. See "System Piping" section for piping configurations with circulator located on supply main piping using zone circulators or zone valves. When piping is arranged with zone circulators and no bypass piping, circulator provided with boiler may be used as zone circulator. Both piping arrangements allow circulator to pump away from expansion tank and show how piping should be arranged to allow heating system to be easily purged of air.

**Taco 007 Pump Curve**

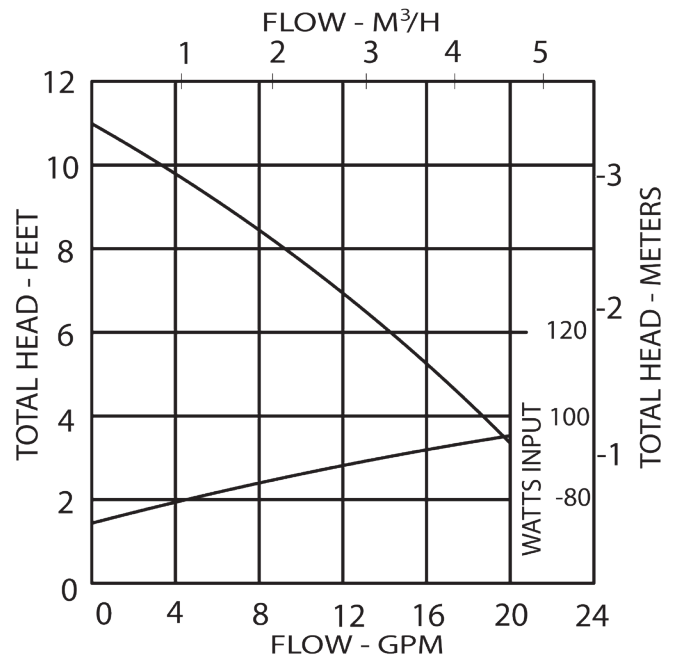

## **IMPORTANT**

In accordance with Section 325 (f) (3) of the Energy Policy and Conservation Act, this boiler is equipped with a feature that saves energy by reducing the boiler water temperature as the heating load decreases.

This feature is equipped with an override which is provided primarily to permit the use of an external energy management system that serves the same function.

**THIS OVERRIDE MUST NOT BE USED UNLESS AT LEAST ONE OF THE FOLLOWING CONDITIONS IS TRUE:**

- An external energy management system is installed that reduces the boiler water temperature as the heating load decreases.
- This boiler is not used for any space heating
- This boiler is part of a modular or multiple boiler system having a total input of 300,000 BTU/hr or greater.
- This boiler is equipped with a tankless coil.



**PRODUCT LITERATURE**

Lennox Industries Inc.  
Dallas, Texas