



**COLUMBIA COMPANY**  
 Main offices and Factory:  
 Pittstown, PA

# CSFH III WATER

## OIL FIRED CAST IRON BOILER

### INSTALLATION, OPERATION & MAINTENANCE MANUAL

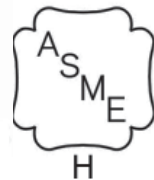
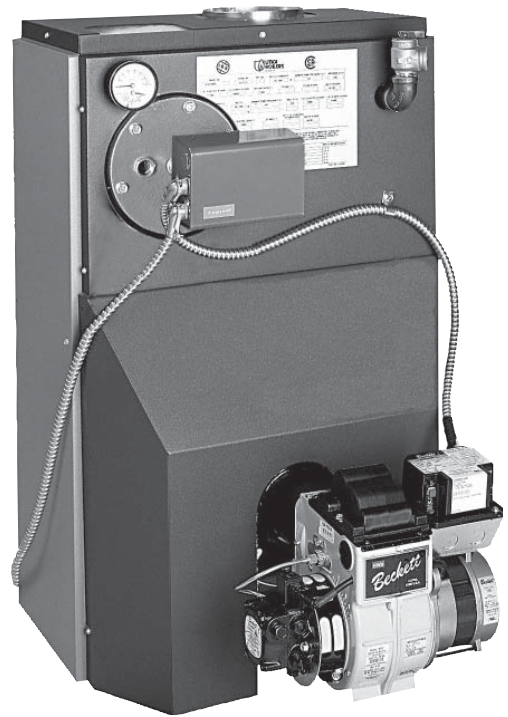

Tested For 75 psi  
 ASME  
 Working Pressure



**Manufactured by:**  
**ECR International, Inc.**  
 2201 Dwyer Avenue, Utica NY 13501  
 web site: [www.ecrinternational.com](http://www.ecrinternational.com)

## TABLE OF CONTENTS

Safety Symbols .....	2
Dimensions.....	3
Boiler Ratings, Capacities .....	4
Introduction.....	5
Ventilation & Combustion Air .....	6
Connecting Supply & Return Piping .....	9
Tankless Heating Piping .....	13
3/4" Tapping Options .....	14
Venting System Inspection & Installation .....	15
Oil Tank Installation & Piping .....	16
Electrical Wiring .....	17
Thermostat Installation .....	17
Operating Instructions.....	18
Service Check List .....	22
Replacement Parts.....	23

### SAFETY SYMBOLS

The following defined symbols are used throughout this manual to notify the reader of potential hazards of varying risk levels.

	<b>DANGER</b>
Indicates a hazardous situation which, if not avoided, <b>WILL</b> result in death or serious injury.	
	<b>WARNING</b>
Indicates a hazardous situation which, if not avoided, could result in death or serious injury.	
	<b>CAUTION</b>
Indicates a hazardous situation which, if not avoided, may result in minor or moderate injury.	
	<b>NOTICE</b>
Indicates information which should be followed to ensure proper installation and operation.	

**Keep this manual near boiler and  
Retain for future reference**

### WARNING

Keep boiler area clear and free from combustible materials, gasoline and other flammable vapors and liquids.

**DO NOT** obstruct air openings to the boiler room.

Modification, substitution or elimination of factory equipped, supplied or specified components may result in property damage, personal injury or the loss of life.

To the owner: Installation and service of this boiler must be performed by a qualified installer.

**To the installer:** Leave all instructions with the boiler for future reference.

When this product is installed in the Commonwealth of Massachusetts the installation must be performed by a Licensed Plumber or Licensed Gas Fitter.

**IMPORTANT:** Read the following instructions **COMPLETELY**  
before installing!

## DIMENSIONS

### WARNING



All installations of boilers and venting should be done only by qualified expert and in accordance with the appropriate Manufacturer's Installation, Operation and Maintenance Manual. Installing or venting boiler or any other appliance with improper methods or materials may result in serious injury or death due to fire or to asphyxiation from poisonous gases such as carbon monoxide which is odorless and invisible.

BOILER SECTION	A LENGTH OF FLUSH JACKET	B FRONT OF CASTING TO CENTER LINE OF FLUE OUTLET	C DIA. OF FLUE OUTLET
3	17 7/8"	11 1/4"	6"
4	21 1/2"	12 5/8"	6"
5	25 1/8"	14 1/4"	7"
6	29 1/4"	15 15/16"	8"
7	32 7/8"	17 15/16"	8"

### NOTES:

- Add suffix "T" to denote boiler with tankless heater.
- Burner capacity is based on an oil heating value of 140,000 Btu/gal. and with 13% CO<sub>2</sub>.
- Net ratings based on 170° F temperature in radiators and include 15% allowance for normal piping and pickup load. Consult manufacturers for unusual piping and pickup requirements.  
*\* All ratings subject to verification.*
- For equivalent square feet of radiation, divide output by 150.
- 120 Volts, 15 Amps, & 60 Hz required to operate this boiler.
- For altitudes above 2,000 ft. ratings may be reduced at rate of 4% for every 1,000 ft. above sea level.

### DIMENSIONAL DATA

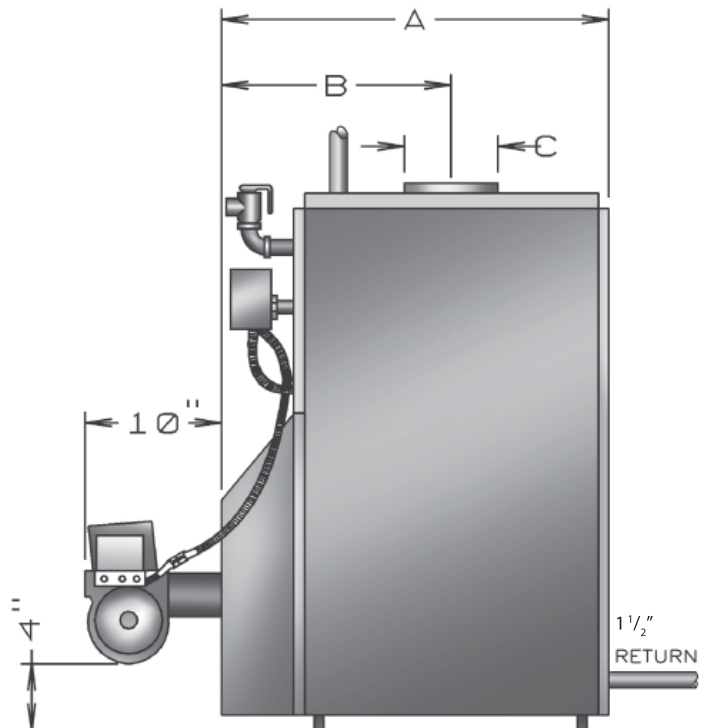
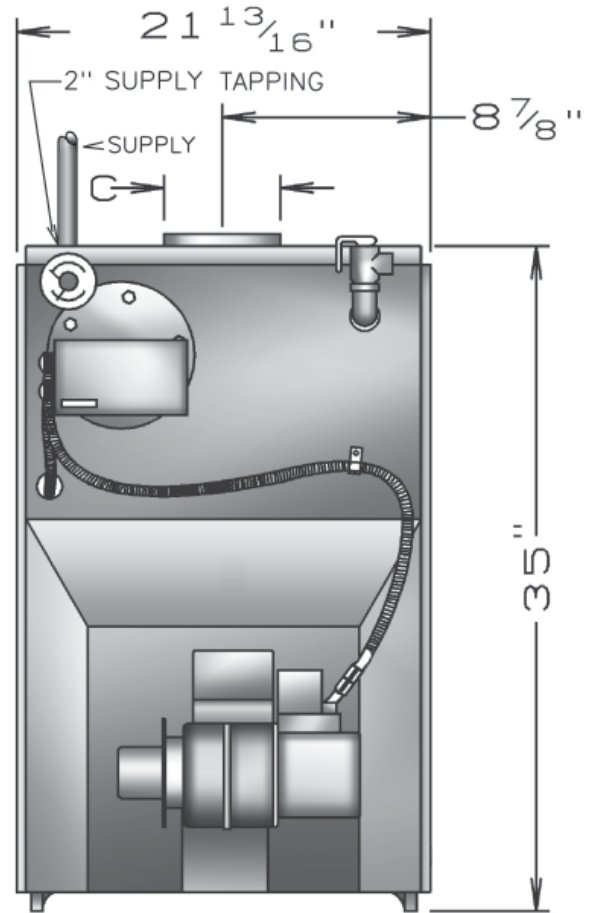

## BOILER RATINGS & CAPACITIES

### BOILER RATINGS

(1) BOILER MODEL NUMBER	(2) OIL BURNER INPUT		HEATING CAPACITY	(3) NET RATINGS WATER	A.F.U.E.  RATING	MINIMUM NATURAL DRAFT CHIMNEY SIZE		PUMP PRES- SURE  PSI
	**gph	*Mbh				*Mbh	*Mbh	
3100	1.00	140	117	102	81.0	6	8X8X15	140
3125	1.25	175	144	125	80.0	7	8X8X15	140
4125	1.25	175	149	130	82.5	7	8X8X15	140
4150	1.50	210	175	152	81.0	7	8X8X15	140
5175	1.75	245	206	179	81.5	8	8X8X15	140
5200	2.00	280	231	210	81.0	8	8X8X15	140

\*Mbh = 1,000 BTU per hour [BTU = British Thermal Unit]

\*\* gph = Gallons per hour oil at 140,000 BTU per gallon

<sup>1</sup> Consult manufacturer before selecting a boiler for installation having unusual piping and pickup requirements, such as intermittent system operation, extensive piping systems, etc.

<sup>2</sup> For forced hot water heating systems where boiler and all piping are within the area to be heated, boiler may be selected on basis of heating capacity.

<sup>3</sup> Net water ratings shown are based on a piping and pickup allowance of 1.15.

**STANDARD EQUIPMENT:** Crated Boiler, Flush Jacket, Oil Burner, Target Wall/Liner, Circulator- 1¼", ASME Relief Valve, Temperature Pressure Gauge, Drain Valve, Wiring Harness, Burner Electrical Disconnect, Plastic Cover, Supply Tapping-2", Return Tapping-1 1/2", High Limit and Circulator Control, Primary Control. For Tankless Heater Units add Tankless Hot Water Coil, Flow Restrictor and Triple Limit Relay.

### TANKLESS WATER HEATER CAPACITIES

BOILER MODEL NUMBER	FIRING RATE G.P.H.	TANKLESS HEATER NUMBER	TANKLESS HEATER CAPACITY INTERMITTENT DRAW G.P.M.	BOILER WATER CONTENT GALS.
3100	1.00	T3	3.25	10.5
3125	1.25	T3	3.75	10.5
4125	1.25	T4	3.75	13.5
4150	1.50	T4	4.00	13.5
5175	1.75	T4	4.25	16.5
5200	2.00	T4	5.50	16.5

## INTRODUCTION

### WARNING



Improper installation, adjustment, alteration, service or maintenance can cause personal injury or loss of life.

Installations must conform to requirements of the authority having jurisdiction. Such applicable requirements take precedence over the general instructions of this manual.

Where required by the authority having jurisdiction, the installation must conform to the American Society of Mechanical Engineers Safety Code for Controls and Safety Devices for Automatically Fired Boilers, ANSI/ASME No. CSD-1.

LOCATE BOILERS in front of final position before removing crate. Provide a level solid base as near the chimney as possible, and centrally located with respect to the heat distribution system as practical.

### WARNING



Boiler may not be installed on combustible flooring.

Allow 24 inches in the front and top for servicing and cleaning, or removing tankless water heating coil.

When installed in utility room, door should be wide enough to allow largest boiler part to enter, or to permit replacement of another appliance such as water heater.

Boiler must not be installed on carpeting or vinyl flooring.

Minimum clearances to combustible construction are:

TOP .....	24 IN.
FRONT .....	24 IN.
FLUE CONNECTOR .....	9 IN.
REAR .....	6 IN.
SIDES .....	6 IN.

### NOTICE

Clearance for access should exceed fire protection clearance.

***REMOVE CRATE*** and plastic protective wrapper, inspect for damage. All equipment is carefully manufactured, inspected and packaged. Our responsibility ceases upon delivery of crated boiler to carrier in good condition. Any claims for damage or shortage in shipment must be filed immediately against the carrier by cosigner. Move boiler to permanent position by sliding or walking.

**WARNING**



Air openings to combustion area must not be obstructed. Follow chart below to obtain and maintain adequate combustion air.

<b>COMBUSTION AIR REQUIREMENTS (MINIMUM OPENING IN SQUARE INCHES)</b>				
<b>BTU/HR INPUT</b>	<b>*UNCONFINED AREA</b>		<b>**CONFINED AREA</b>	
	<b>OUTSIDE COMBUSTION AIR</b>	<b>INSIDE COMBUSTION AIR</b>	<b>OUTSIDE COMBUSTION AIR</b>	
	1 IN <sup>2</sup> /5000BTU/HR (PARAGRAPH 4)	1 IN <sup>2</sup> /1000 BTU/HR (MIN 100IN <sup>2</sup> ) (Figure 1)	1 IN <sup>2</sup> /4000 BTU/ HR (Figures 2&3)	1 IN <sup>2</sup> /2000 BTU/ HR (Figure 4)
91,000	19	100	23	46
140,000	28	140	35	70
175,000	35	175	44	88
210,000	42	210	53	106
245,000	49	245	61	122
280,000	56	280	61	140

\* Unconfined area: A space whose volume is not less than 50 cubic feet per 1000 BTU per hour of all appliances installed in that space (cubic feet of space = height x width x length).

\*\* Confined area: A space whose volume is less than 50 cubic feet per 1000 BTU per hour of all appliances installed in that space (cubic feet of space = height x width x length).

- Ventilation of boiler room must be adequate enough to provide sufficient air to properly support combustion.
- When boiler is located in an unconfined space in a building of conventional construction frame, masonry or metal, infiltration normally is adequate to provide air for combustion and ventilation. However, in any building which has been altered to conserve energy or to minimize infiltration, the boiler area should be considered as a CONFINED SPACE. Provide combustion air and ventilation air in accordance with the section "Air for Combustion and Ventilation," of the National Fuel Gas Code, ANSI Z223.1 / NFPA 54, or applicable provisions of local building codes.
- When a boiler is installed in an unconfined space, in a building of unusually tight construction, air for combustion and room ventilation must be obtained from outdoors or from spaces freely communicating with the outdoors. A permanent opening or openings having a total free area of not less than 1 square inch per 5,000 BTU per hour of total input rating of all appliances shall be provided. Ducts may be used to convey make-up air from the outdoors and shall have the same cross-sectional area of the openings to which they are connected.
- When air for combustion and room ventilation is from inside buildings, confined space shall be provided with two permanent openings, one starting 12 inches from the top and one 12 inches from the bottom of the enclosed space. Each opening shall have a minimum free area of 1 square inch per one thousand (1,000) BTU per hour of the total input rating of all appliances in the enclosed space, but must not be less than one hundred (100) square inches. These openings must freely communicate with the interior areas having adequate infiltration from the outside. See **Figure #1**.
- When the boiler is installed in a confined space and all air is provided from the outdoors, the confined space shall be provided with two permanent openings, one commencing within 12 inches from the top and one commencing 12 inches from the bottom of the enclosure. The openings shall communicate directly, or by ducts, with the outdoors or spaces (crawl or attic) that freely communicate with the outdoors. One of the following methods must be used to provide adequate air for ventilation and combustion.

- A. When directly communicating with the outdoors, each opening shall have a minimum free area of 1 square inch per 4,000 BTU per hour of total input rating of all equipment in the enclosure. See **Figure #2**.
  - B. When communicating with the outdoors by means of vertical ducts, each opening shall have a minimum free area 1 square inch per 4,000 BTU per hour of total input rating of all appliances in the enclosed space. See **Figure #3**.
  - C. If horizontal ducts are used, each opening shall have a minimum free area 1 square inch per 2,000 BTU per hour total input rating of all appliances in the enclosed space. See **Figure #4**.
  - D. When ducts are used, they shall be of the same cross sectional area as the free area of the area of the openings to which they connect. The minimum dimension of rectangular air ducts shall not be less than 3 inches.
6. In calculating free area using louvers, grills or screens for the above, consideration shall be given to their blocking effect. Screens used shall not be smaller than ¼ inch mesh. If the free area through a design of louver or grill is known, it should be used in calculating the size opening required to provide the free area specified. If the design and free area is not known, it may be assumed that wood louvers will have 20-25% free area and metal louvers and grills will have 60-75% free area. Louvers and grills shall be fixed in the open position or interlocked with the boiler so that they are opened automatically during boiler operation. Refer to the *Combustion Air Requirements* chart on previous page for combustion air minimum opening requirements.

Figure #1

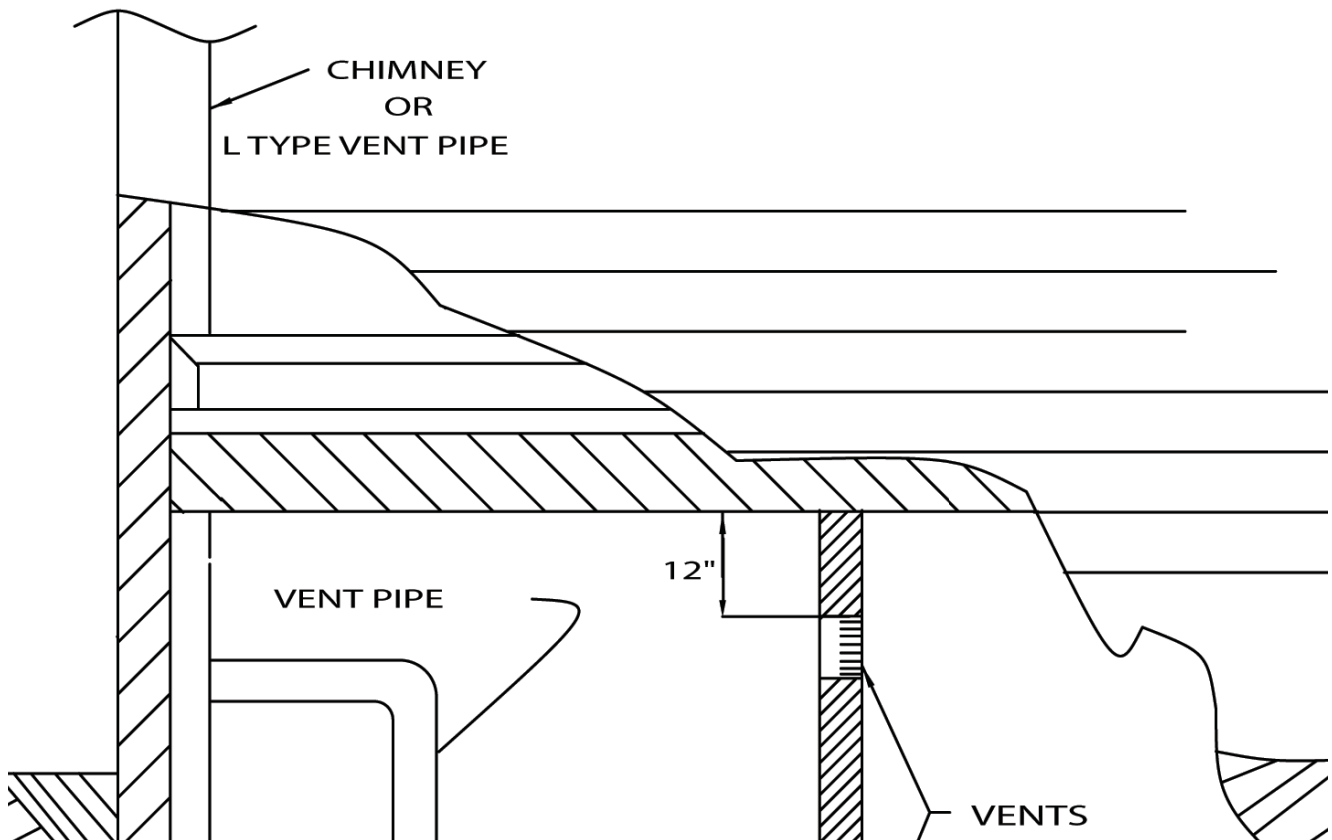

Figure #2

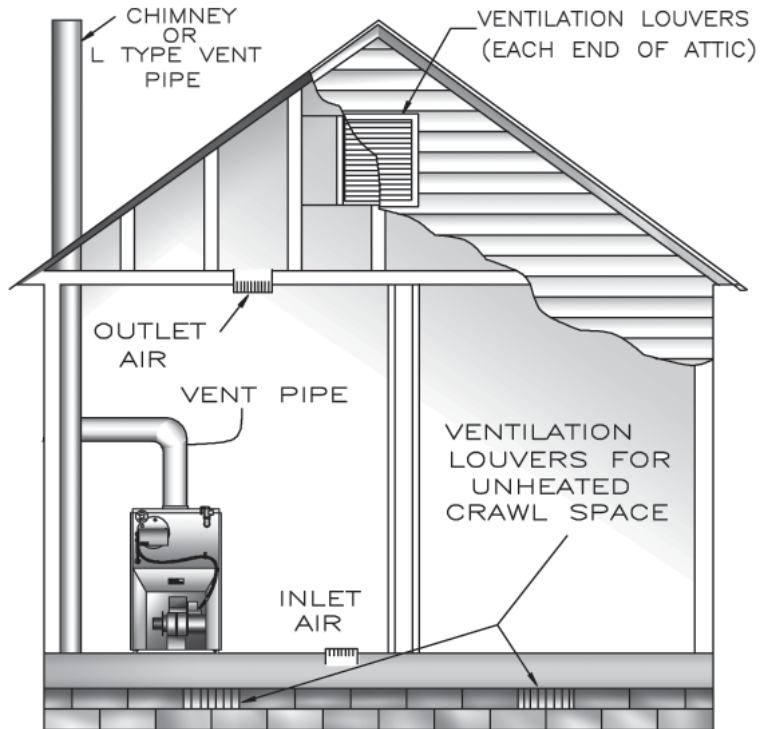

Figure #3

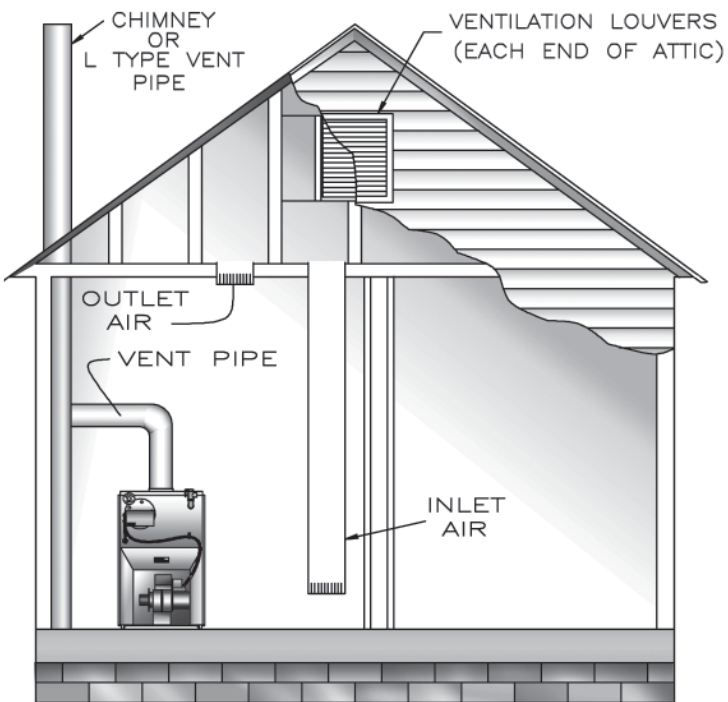
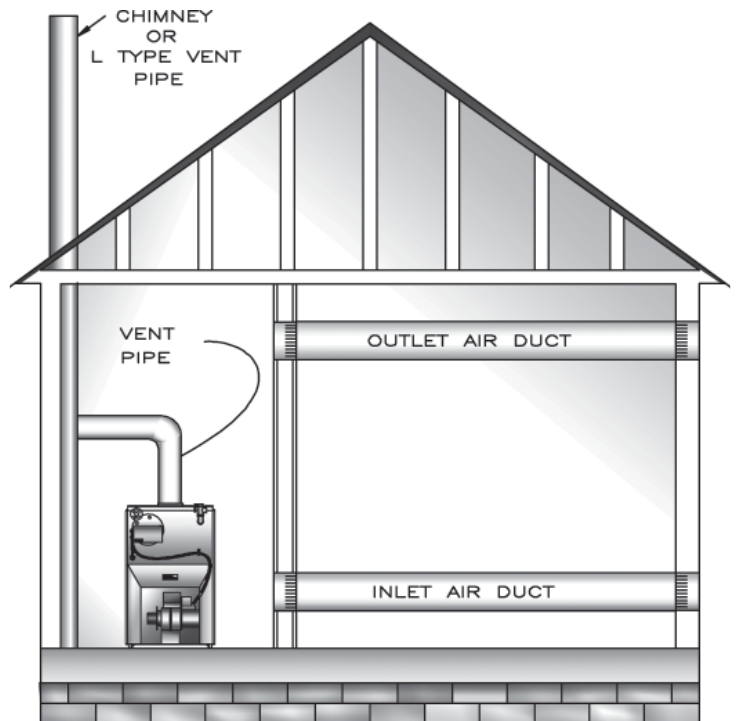

Figure #4





## CONNECTING SUPPLY AND RETURN PIPING

1. Connect supply and return piping as suggested in **Figure #5**, below. When boiler is used in connection with refrigerated systems:
  - A. Chilled medium **MUST BE IN PARALLEL** with boiler.
  - B. Use appropriate valves to prevent chilled medium from entering heating boiler.
2. During heating cycle open valves A and B, close valves C and D.
3. During heating cooling cycle open valves C and D, close valves A and B.
  - A. Maintain minimum clearance of one inch to hot water pipes.
4. Hot water boilers installed above radiation level must be provided with low water device either as part of boiler or at time of boiler installation.
5. When boiler is connected to heating system utilizing multiple zoned circulators, each circulator must be supplied with flow control valve to prevent gravity circulation.
 

*\* Reduced pressure back flow preventer must be used under provisions required by the Environmental Protection Agency, (EPA).*
6. Bypass piping is an option which gives ability to adjust supply boiler water temperature to fit system or condition of installation. Although, this method of piping is not typically required for baseboard heating systems.

In air handling units where they may be exposed to refrigerated air circulation, boiler piping system **MUST** be supplied with flow control valves or other automatic means to prevent gravity circulation of boiler water during cooling cycle.

**Figure #5**

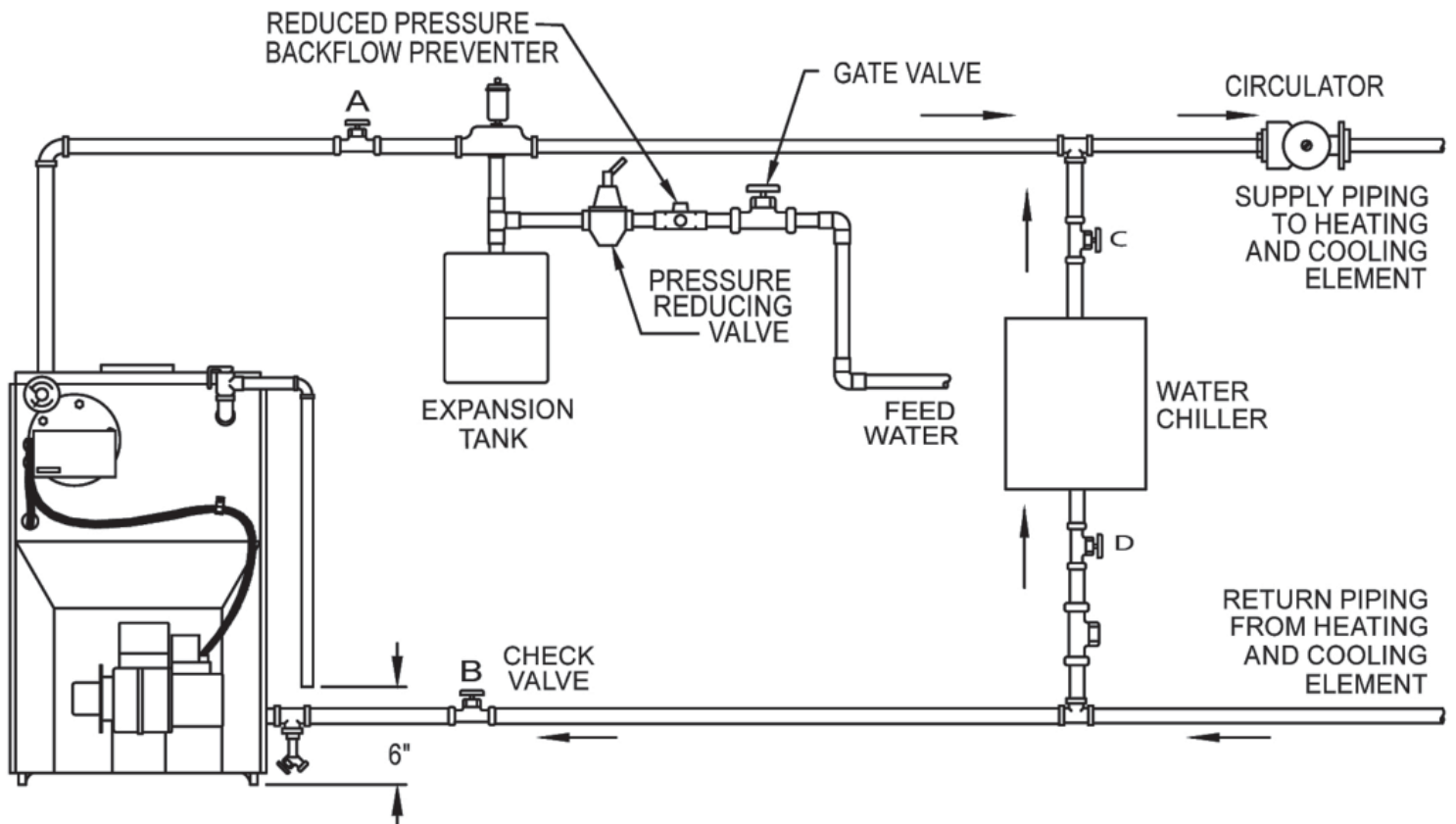

## CONNECTING SUPPLY AND RETURN PIPING

- A. This method is used to protect boilers from condensate forming due to low temperature return water. Generally noticed in large converted gravity systems or other large water volume systems. See **Figure #6**.
- B. These methods are used to protect systems using radiant panels and material they are encased in from high temperature supply water from boiler and protect boiler from condensation. See **Figures #7 and #8** following page.
- C. This method is used to protect boilers from condensate forming as well as protecting heating system from high water temperature. See **Figure #8** following page.
- Note:** When using bypass piping, adjust valves A and B until desired system temperature is obtained.
7. Bypass loop piping must be same size piping for supply and return.

Figure #6 Bypass Piping

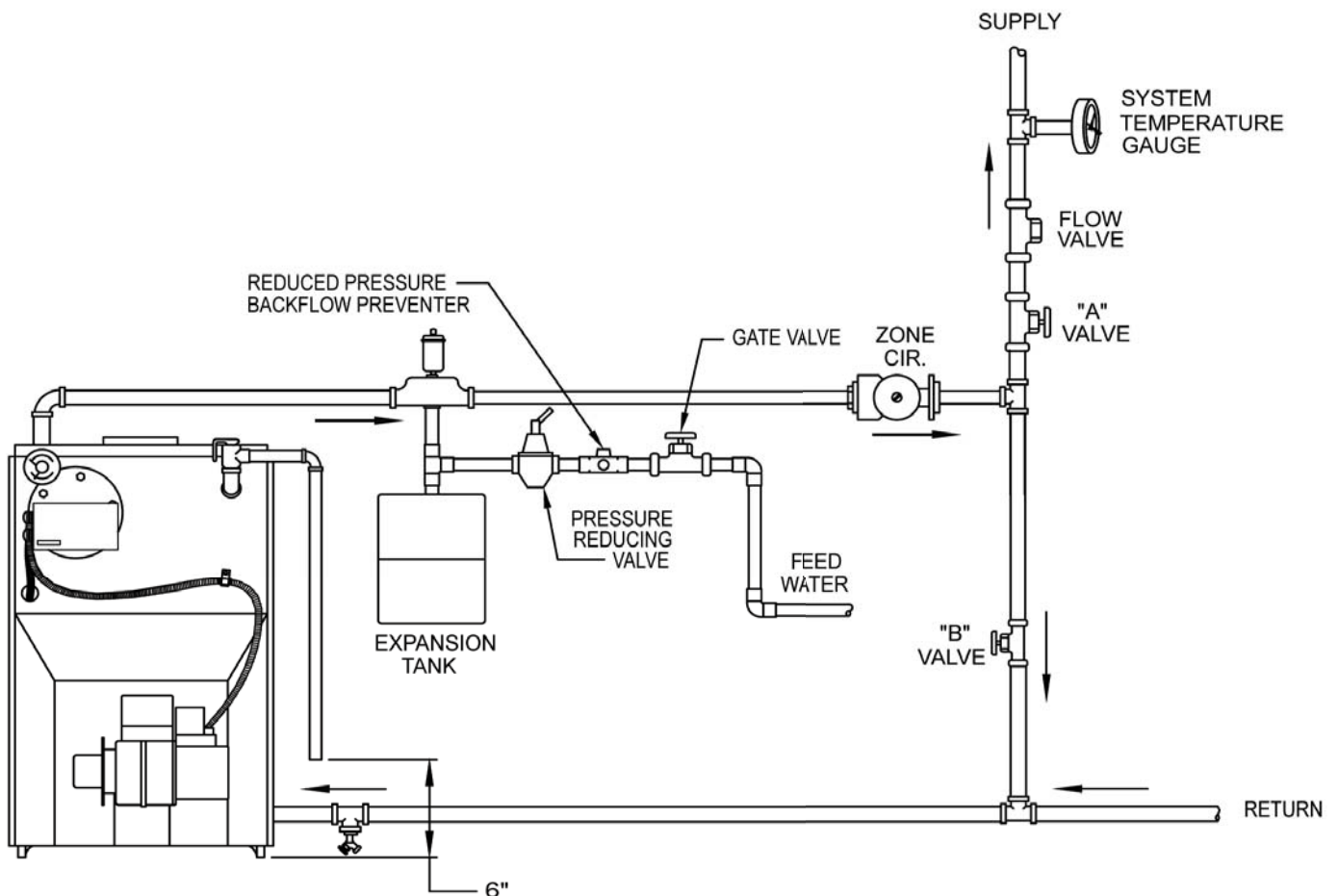

Figure #7 - Mixing Valve Piping

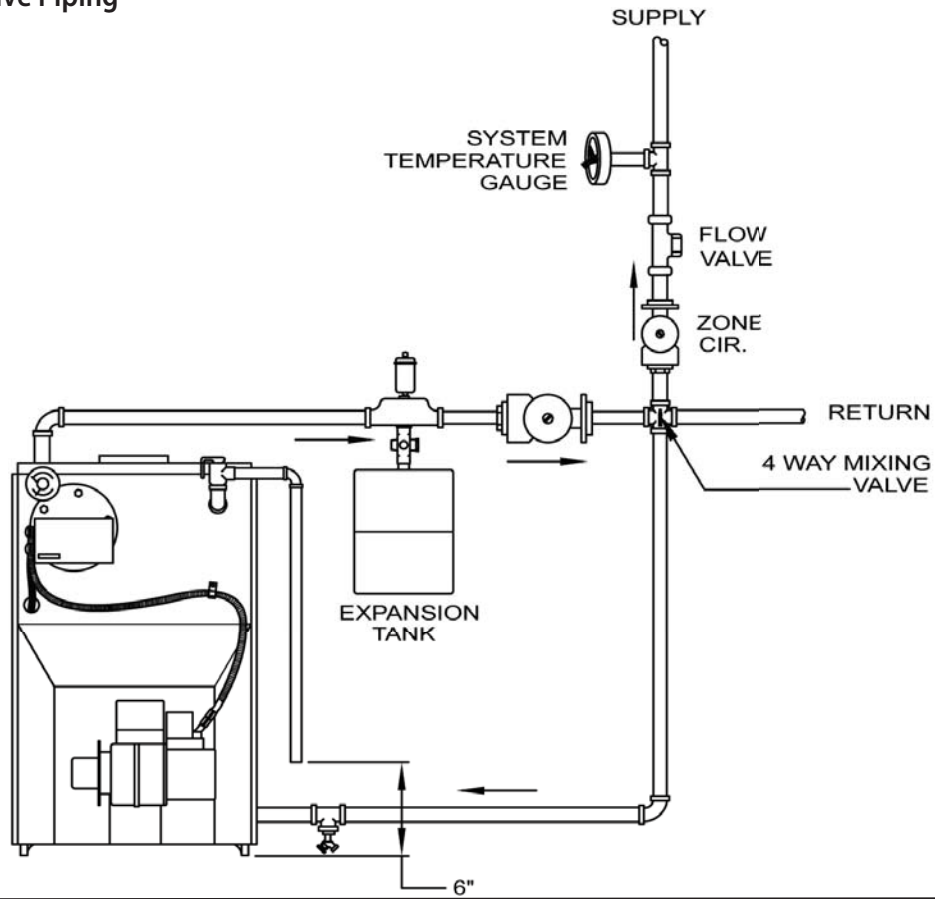
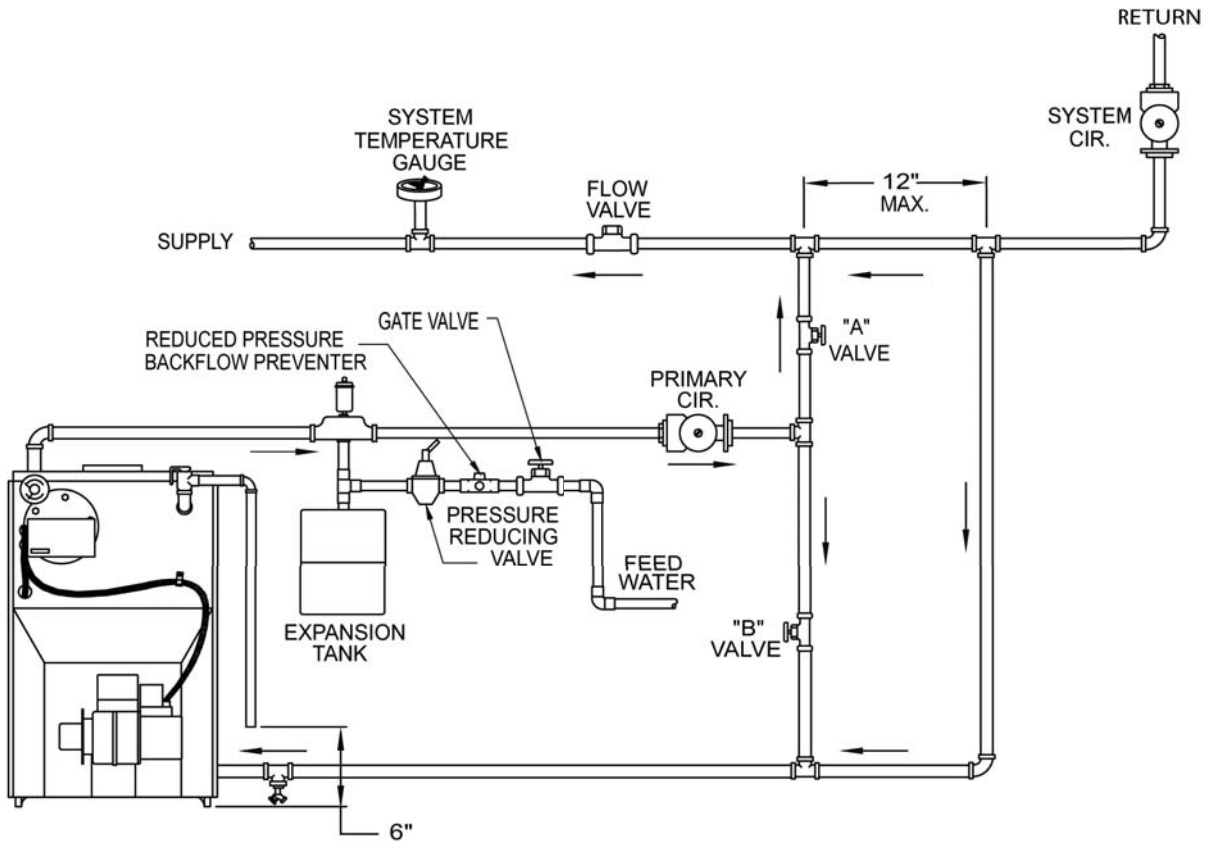

Figure #8 - Primary Secondary Piping With Bypass



## CONNECTING SUPPLY AND RETURN PIPING

8. Typical installation using circulators is shown in **Figure #9**.
9. Typical installation using zone valves is shown in **Figure #10**.
10. For further piping information refer to AHRI installation and piping guide.

**Figure #9 - Primary Secondary Piping With Bypass**

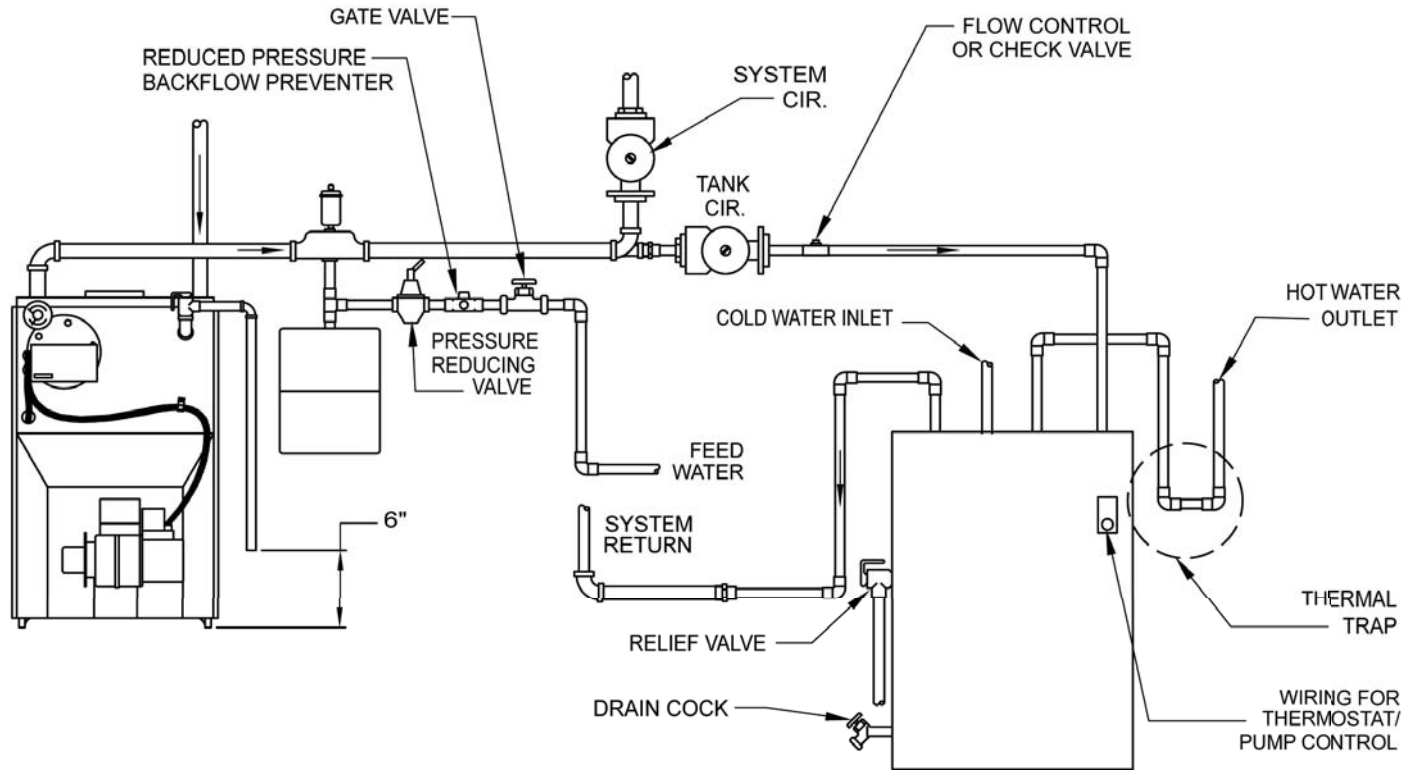

**Figure #10 - Primary Secondary Piping With Bypass**

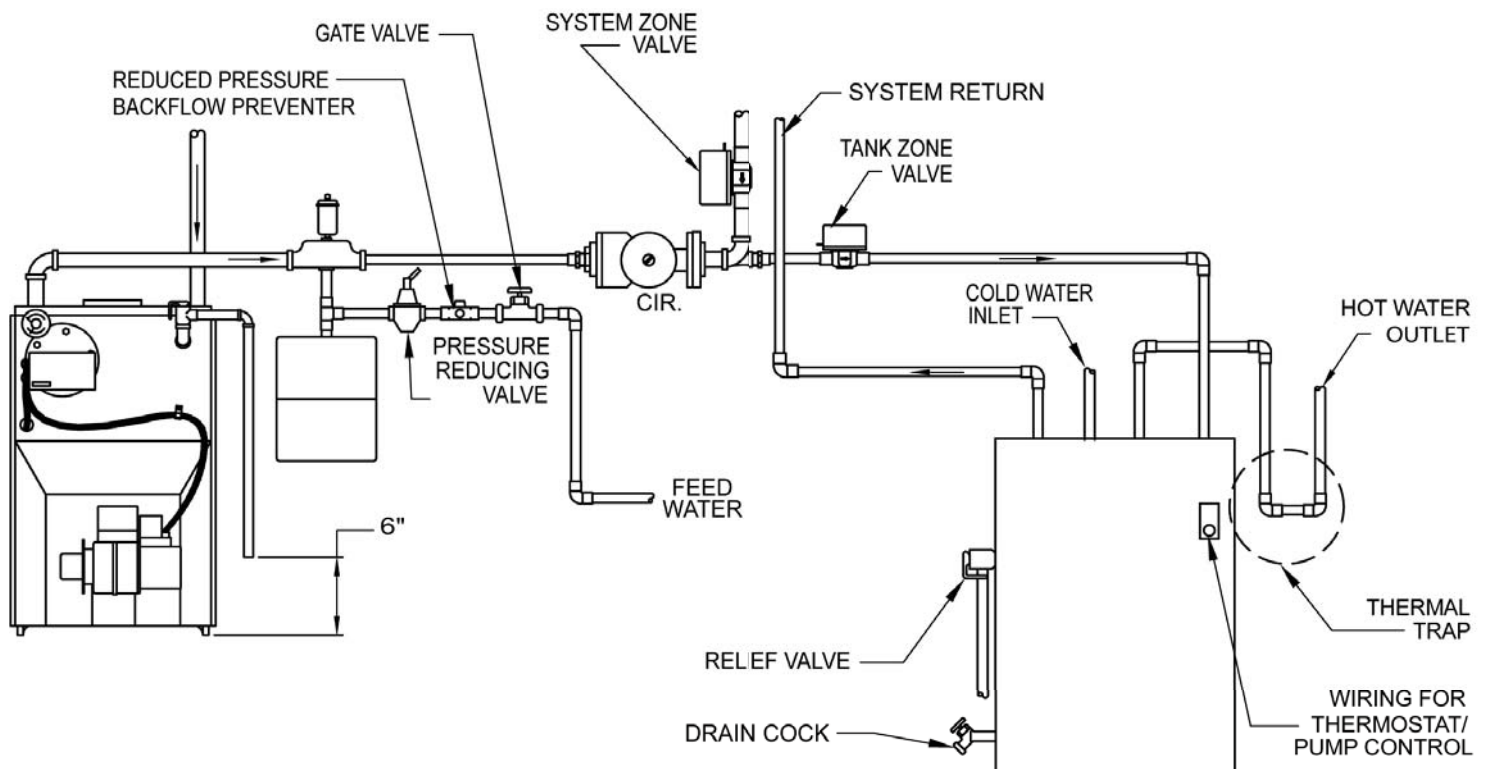
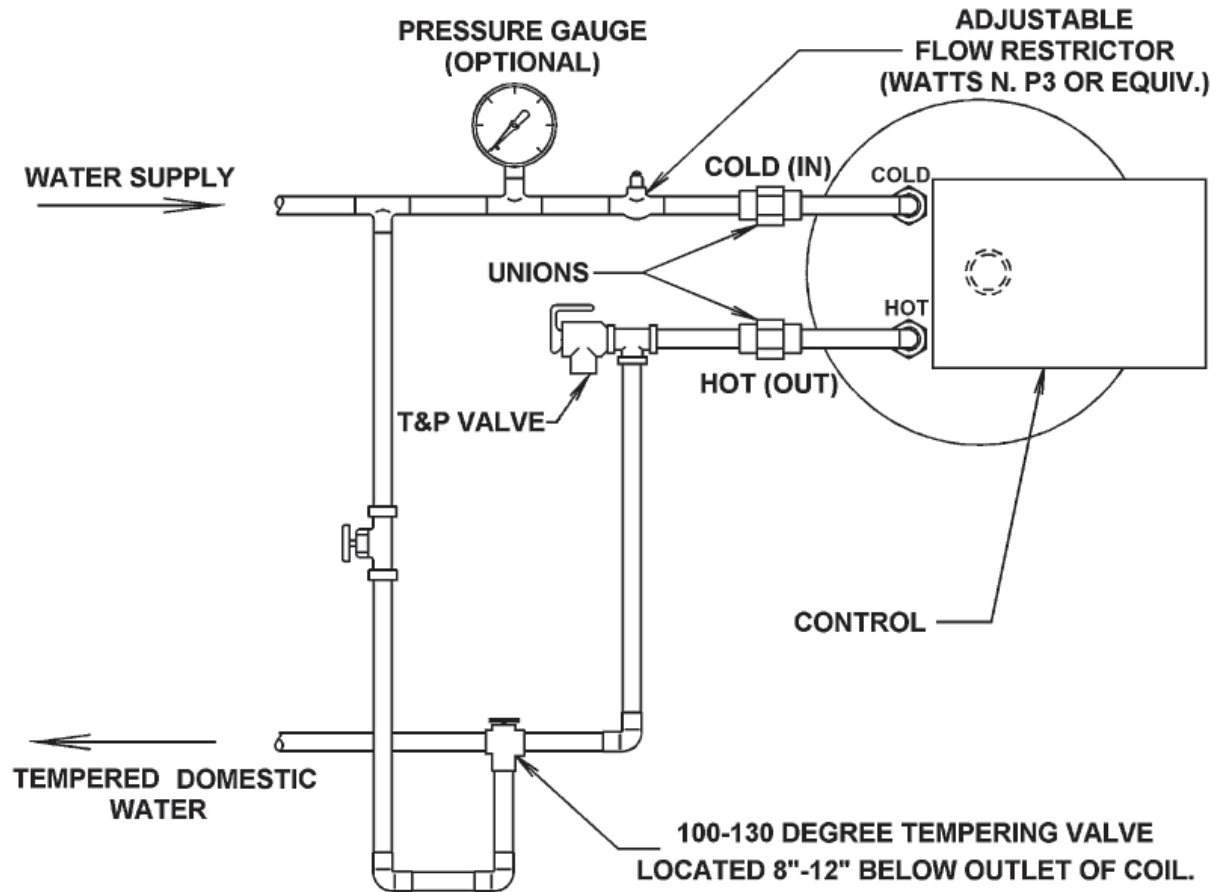

Figure #11 - Recommended Piping For Boilers Equipped With T3 Or T4 Tankless Heater

**DANGER**

Water temperatures exceeding 125°F will cause severe burns instantly or death by scalding.

- Automatic mixing valve must be installed on outlet of domestic coil. Installation must comply with valve manufacturer's recommendations, and instructions.
- Do not remove bolts or aquastat at time of installation.
- Pipe in accordance with boiler's Installation, Operation and Maintenance Manual.
- Due to varying water conditions, adjustable flow restricter must be installed in cold water inlet of this coil.

CONNECTING SUPPLY AND RETURN PIPING

OPTIONS UTILIZING 3/4" TAPPING

Figure #12 - Optional Location For Air Vent

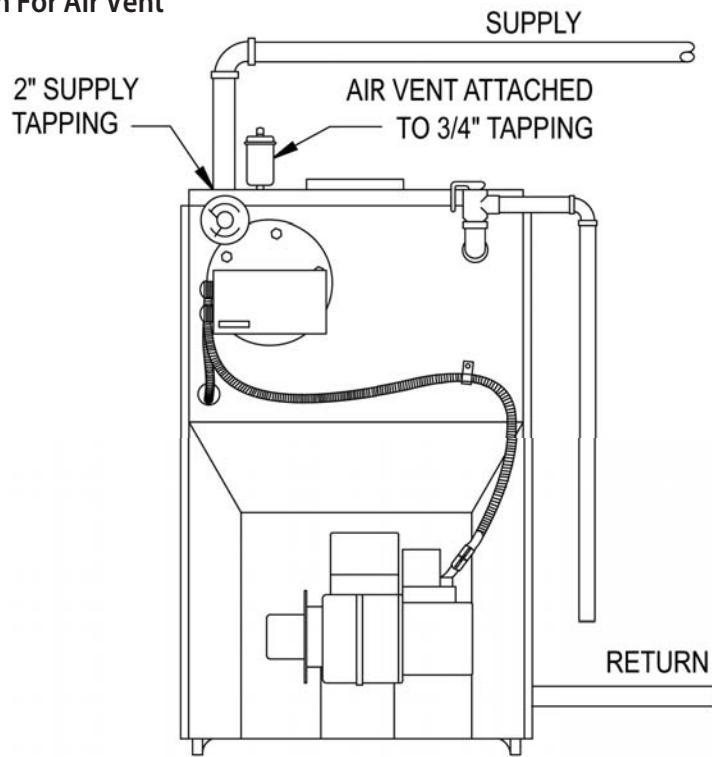
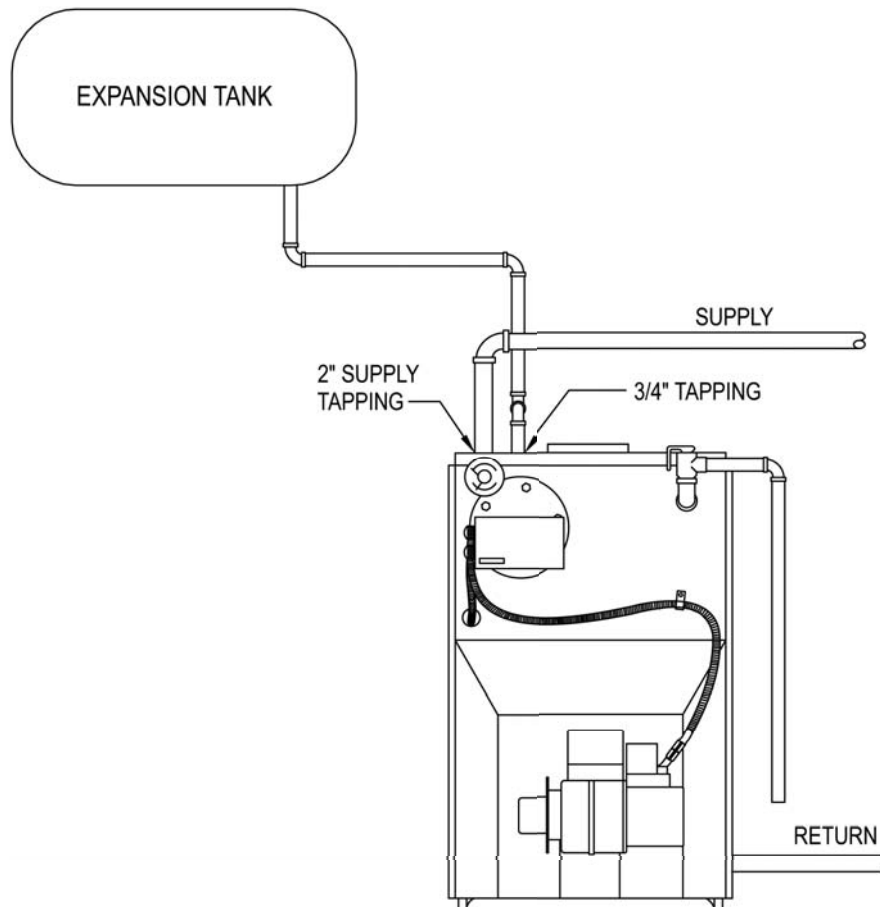

Figure #13 - Optional Location For Expansion Tank (Non-Diaphragm Type)



**INSPECT CHIMNEY** to make certain it is constructed according to latest revision of the NFPA 211. Local codes may differ from this code and should be checked. Where there is a conflict, local code will prevail. In Canada refer to National Building Code or CSA-A405 as applicable.

Boiler must be installed into chimney which has masonry or metallic chimney liner.

Unlined chimney will have leaks that will cause poor chimney performance (NO DRAFT), and could result in poor positive pressure in combustion chamber.

Horizontal portions of venting system should not exceed 10 feet in length. Horizontal lengths over 10 feet will have negative effect on chimney performance.

Chimney should extend at least 2 feet above any portion of building within 10 feet. See **Figure #14**. It should produce negative draft of .06 to .08 inches of water column, (W.C.), as measured with draft gauge between boiler and barometric draft control while maintaining .02 inch W.C. negative draft in combustion chamber. See chart "Chimney or Vent Sizes" for recommended chimney or vent sizes.

Inadequate draft will cause improper combustion, resulting in dirty flue ways and high fuel bills.

**CONNECT FLUE PIPE** same size as boiler outlet to chimney, sloping upward continuously toward chimney approximately 1/4" per foot. Bolt or screw joints together to avoid sag.

If oil fired water heater is vented into same flue as boiler, provide separate hole into chimney whenever possible. When not possible, use "Y" connection in flue pipe, using separate draft regulator for each unit. When chimney will not provide adequate draft to handle input from water heater and boiler simultaneously, wire units so that only one will operate at a time, favoring water heater.

Figure #14

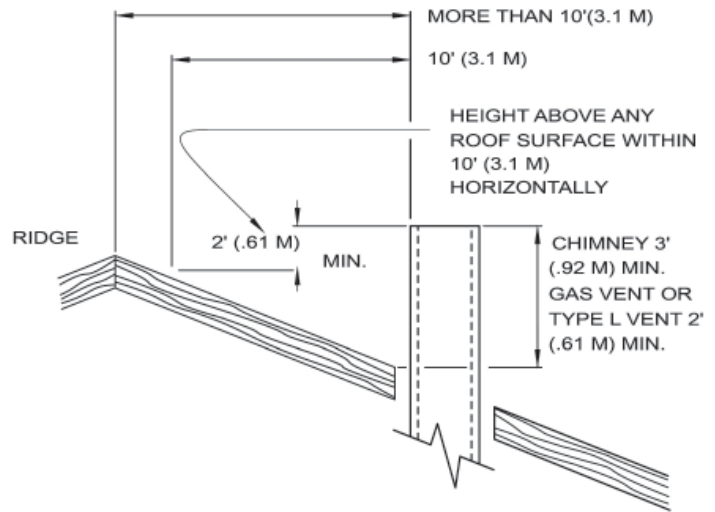

CHIMNEY OR VENT SIZES						
MODEL NO.	ROUND INCHES		SQUARE INCHES		HEIGHT FEET	
	MIN	MAX	MIN	MAX	MIN	MAX
3100	6	8	8X8	8X8	15	40
4125,3125 4150	7	8	8X8	8X10	15	40
5175,5200	8	10	8X8	8X12	15	50

## OIL TANK AND PIPING

Install oil tank and piping in accordance with the National Board of Fire Underwriters and local regulations. Oil storage tank, vent, fill pipe and caps should be as prescribed by local codes. In no case should vent pipe be smaller than 1¼" I.P.S. Fill pipe should not be less than 2" I.P.S.

Suction line from tank to burner should be one continuous piece of tubing to prevent air entering line. Suction line, must be ¾" O.D. copper tubing for runs of 50 feet or less, and ½" O.D. for longer runs. Oil return line, same size as suction line, must be used on any installation where bottom of tank is below fuel unit of burner. Oil lines should be buried or otherwise protected from mechanical injury. Flare fittings on all oil lines are recommended. Compression fittings on suction line often allow air to be drawn into fuel pump, making it difficult to maintain oil pressure at nozzle. Do not run overhead fuel lines from tank to oil burner.

Fuel pump connections and by-pass should be made according to instructions attached to fuel pump. If tank is more than 20' from boiler, a two stage fuel unit should be installed in place of single stage pump supplied as standard equipment with burner. Make certain rotation and speed are same and pump is suitable for burner horsepower rating.

Oil line filter and shut-off valve should be installed in suction line. Shut-off valves should be installed in both suction and return lines at burner for convenience in servicing burner. Allow extra tubing at burner so burner may be removed from boiler for cleaning without disconnecting tubing. (See **Figures #15 & #16**, below). An optional flexible oil line is available.

Figure #15 - Typical Installation Single Pipe Oil System

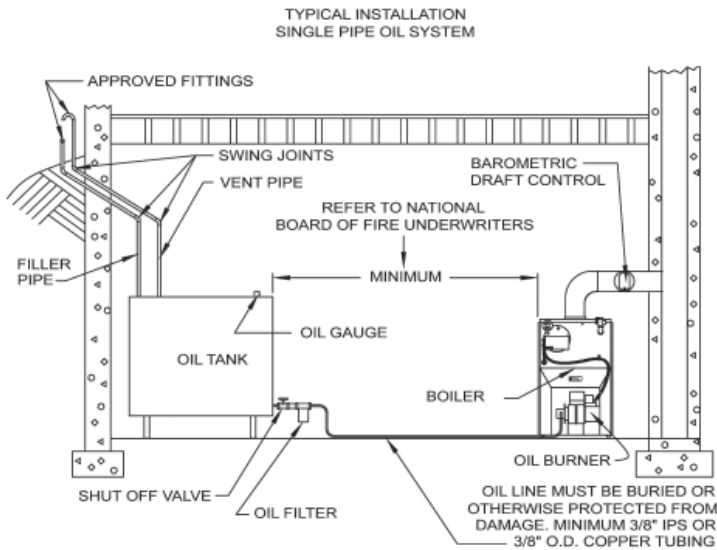
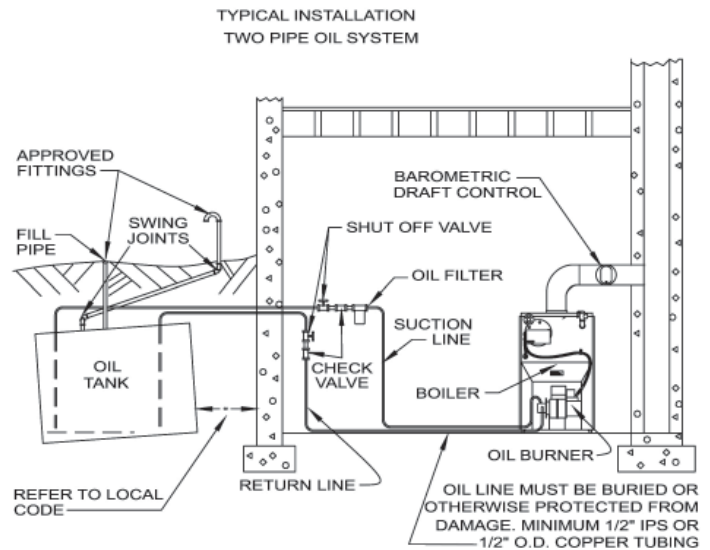

Figure #16 - Typical Installation Two Pipe Oil System





## ELECTRICAL WIRING

### SEE WIRING ADDENDUM FOR WIRING DIAGRAMS AND COMPONENT CODING.

Electrically bond boiler to ground in accordance with requirements of authority having jurisdiction. Refer to:

- USA- National Electrical Code, ANSI/NFPA 70.
- Canada - Canadian Electrical Code, Part I, CSA C22.1: Safety Standard for Electrical Installations.

Install fused disconnect switch between boiler and meter at convenient location.



### WARNING

Electrical shock hazard. Turn OFF electrical power supply at service panel before making electrical connections. Failure to do so could result in death or serious injury.

## THERMOSTAT INSTALLATION

1. Thermostat should be installed on inside wall about four feet above the floor.
2. **NEVER** install thermostat on outside wall.
3. Do not install thermostat where it will be affected by:
  - Drafts
  - Hot or cold pipes
  - Sun light
  - Lighting fixtures
  - Television sets
  - Fireplace or chimney
4. Check thermostat operation by raising and lowering thermostat as required to start and stop burner.
5. Instructions for final adjustment of thermostat are packaged with thermostat ( adjusting heating anticipator, calibration, ect.).

## SEQUENCE OF OPERATIONS

On call for heat, thermostat will actuate, completing circuit to aquastat. In turn, circulator and ignition systems are activated and ignition will begin.

In event boiler water temperature exceeds high limit setting on boiler mounted aquastat, power will be interrupted between aquastat and ignition system. Power will remain off until boiler water temperature drops below high limit setting. Circulator will continue to operate under this condition until thermostat is satisfied.

Venting system should be inspected at start of each heating season. Check vent pipe from boiler to chimney for signs of deterioration by rust or sagging joints. Repair if necessary.

Remove vent pipe at base of chimney or flue and, using mirror, check for obstruction.



### WARNING

Water will be boiling hot.

Lever of pressure relief valve, shown in **Figure #9**, page 12 of this manual, on boiler should be operated periodically to make sure it is functioning properly. Pressure relief valve should open before water pressure exceeds 30 lb. reading on gauge. If this pressure is exceeded and pressure relief valve leaks water when boiler is operating at normal pressures, it should be immediately replaced. Corrosion can build up rapidly at valve seat and prevent its functioning as safety device.

### Start-Up And Adjustment Of Oil Burner

(See oil burner instructions for nozzle and electrode setting)

- A. Check oil burner nozzle to make certain it is tight in adapter. Burner mounting bolts should be tight.
- B. Check electrode setting, they may have been jarred out of position during transportation.
- C. Lubricate burner motor and circulator motor if required. Some circulators are water lubricated and do not require oiling.
- D. Set room thermostat to call for heat, or jump thermostat contacts on the boiler control.
- E. Open all oil line valves.
- F. Turn service switch on. Burner should start.
- G. On one pipe fuel systems only, vent pump as soon as burner starts. Allow oil to run until all traces of air in the suction line disappear.
- H. Turn "OFF" burner and install pressure gauge port on pump.
- I. Start burner again and check oil pressure for 140 lbs. Adjust if necessary.



### CAUTION

Do not set fire visually.

Instruments are only reliable method to determine proper air adjustments. Improperly adjusted burner causes soot and high fuel bills because of incomplete combustion of fuel oil. This in turn may require excessive boiler maintenance, service costs, and in some instances, house cleaning or redecorating. A competent service mechanic should be consulted to make proper adjustments with smoke tester, CO<sub>2</sub> indicator and draft gauge. Bacharach or Dwyer test kits include these instruments.

### Instructions For Proper Operation Of Boiler-Burner Unit

A 1/4" diameter slot is provided in inspection cover plate to take draft readings in combustion chamber. See **Figure #19**. A 1/4" diameter hole will be required in flue pipe between boiler and barometric damper (if used) to take draft, CO<sub>2</sub>, smoke and temperature readings. Adjust air shutter on oil burner to obtain "trace" of smoke. Measure CO<sub>2</sub> at this point. Increase air adjustment to lower CO<sub>2</sub> approximately one (1) percent. Check to insure minimum negative .02 w.c., (water column), "overfire" draft and zero (0) smoke. If - .02 w.c. "overfire" draft can not be maintained, changes and/or modifications may be required in venting or chimney.

Following table (page 20) is provided as guideline for initial start-up. Final adjustments MUST be made using combustion instruments as previously mentioned.

**Check Safety Control Circuit** - after burner adjustments have been made for satisfactory performance.

1. High limit control: remove cover and note temperature setting. See **Figure #19**. With burner operating, decrease setting to minimum point. When boiler water temperature exceeds this set point, high limit switch will open, shutting off power to oil burner. Return setting to desired high limit point. Burner should restart.

2. Primary control and flame sensor check following:

- A. **Flame failure** - simulate by shutting off oil supply with hand valve while burner is on. Sixty seconds after flameout, the safety switch locks out, ignition stops, motor stops and oil valve - when used - closes. To restart, open oil supply valve and reset safety switch.
- B. **Ignition failure** - with burner off, close oil supply valve and run through start-up procedure, The safety switch should lock out as in flame failure.
- C. **Power failure** - Turn off main power supply switch while burner is operating. When burner stops, restore power and burner should start.

If operation is not as described as above, check wiring and controls.

**Preventive Maintenance** - of oil fired boiler reduces operating costs. Boiler and vent pipe should be inspected for accumulation of soot or scale deposits periodically but at least once every year before start of each heating season. When soot is present on section walls and flueways, improper combustion will result, causing additional sooting and scaling until flueways are completely closed. To remove soot and scale from flueways, remove top jacket panel, top clean-out plate, open burner swing door. (See *Figure #19*)

**Periodic Inspection** - and tightening of tankless heater/cover plate bolts will reduce risk of leaks. See *Replacement Parts "Heat Exchanger"* section.

**Instructions For Opening Burner Swing Door**

1. Turn off power to boiler.
2. Allow boiler to cool down.
3. Disconnect power cable at factory supplied burner electrical disconnect. See *Figure #19*
4. Loosen screws on the sides of lower front jacket panel. See *Figure #19*.
5. Pull bottom part of lower front panel forward.
6. Lift lower front panel up and off boiler. See *Figure #19*.
7. Close oil valve. See *Figures #15 & #16*.
8. Disconnect oil line from burner.
9. Do not try to swing door with oil line attached.
10. Remove nut from swing door stud on right hand side of door.
11. Swing open burner and door to the left.

Using flue brush, brush soot and scale into combustion space where it can be removed through swing door opening.

It is recommended to replace nozzle at start of each heating season. Lubricate burner motor and circulator motor - if required - with few drops of good grade light motor oil. Do not over oil. Have competent service person service burner and check controls and check electrodes for carbon or cracks in insulators. Burners should be adjusted to produce conditions shown in *Start-up and Adjustment of Oil Burner* procedure covered earlier in this section.

**WARNING**



- Use only number 2 fuel oil.
- Do not use gasoline, crankcase drainings or any oil containing gasoline.
- Do not attempt to start burner when excess oil has accumulated, when unit is full of vapor or when combustion chamber is very hot.

**NOTICE**

Use caution when vacuuming in the chamber area. Damage to chamber could result.

**OPERATING INSTRUCTIONS**

<b>RIELLO SETTINGS</b>					
<b>BOILER NO.</b>	<b>BURNER NO.</b>	<b>AIR DAMPER</b>	<b>PUMP PRESS.</b>	<b>TURB.</b>	<b>NOZZLE FURNISHED</b>
3100	F-5	3.6	150 PSI	1.0	.85 80W
3125	F-5	4.0	150 PSI	3.0	1.10 60W
4125	F-5	4.0	150 PSI	3.0	1.10 60W
4150	F-5	6.0	150 PSI	4.0	1.25 60W
5175	F-10	3.6	150 PSI	0.0	1.50 80B
5200	F-10	5.0	150 PSI	0.0	1.75 80B

<b>CARLIN SETTINGS</b>					
<b>BOILER NO.</b>	<b>BURNER NO.</b>	<b>AIR DAMPER</b>	<b>PUMP PRESS.</b>	<b>HEAD BAR</b>	<b>NOZZLE FURNISHED</b>
3100	EZ-1	.85	150 PSI	.85-1.00	.85 70B
3125	N/A	N/A	N/A	N/A	N/A
4125	EZ-1	1.00-1.10	150 PSI	1.10-1.25	1.10 70B
4150	EZ-1	1.25-1.35	150 PSI	1.10-1.25	1.25 70B
5175	EZ-2	1.65	150 PSI	1.65-1.75	1.75 70B
5200	EZ-2	1.75	150 PSI	1.65-1.75	1.50 70B

<b>BECKETT SETTINGS</b>							
<b>BOILER NO.</b>	<b>BURNER NO.</b>	<b>AIR BAND</b>	<b>AIR SHUT.</b>	<b>PUMP PRESS.</b>	<b>STATIC DISC</b>	<b>END CONE</b>	<b>NOZZLE FURNISHED</b>
3100	AFG	1	5	140 PSI	3-3/8U	F3	.85 80B
3125	AFII	N/A	6	140 PSI	N/A	N/A	1.10 60B
4125	AFG	1	8	140 PSI	2-3/4"	F4	1.10 80B
4150	AFG	2	6	140 PSI	2-3/4"	F6	1.25 80B
5175	AFG	3	5	140 PSI	3U	F12	1.50 80B H
5200	AFG	5	5	140 PSI	3U	F12	1.75 70B H

*\*NOTE: Model 3125 needs pin # 5,6225 needs a head setting of 1. Nozzle sizes with an H designation are Hago brand, all others are Delevan.*

Figure #19

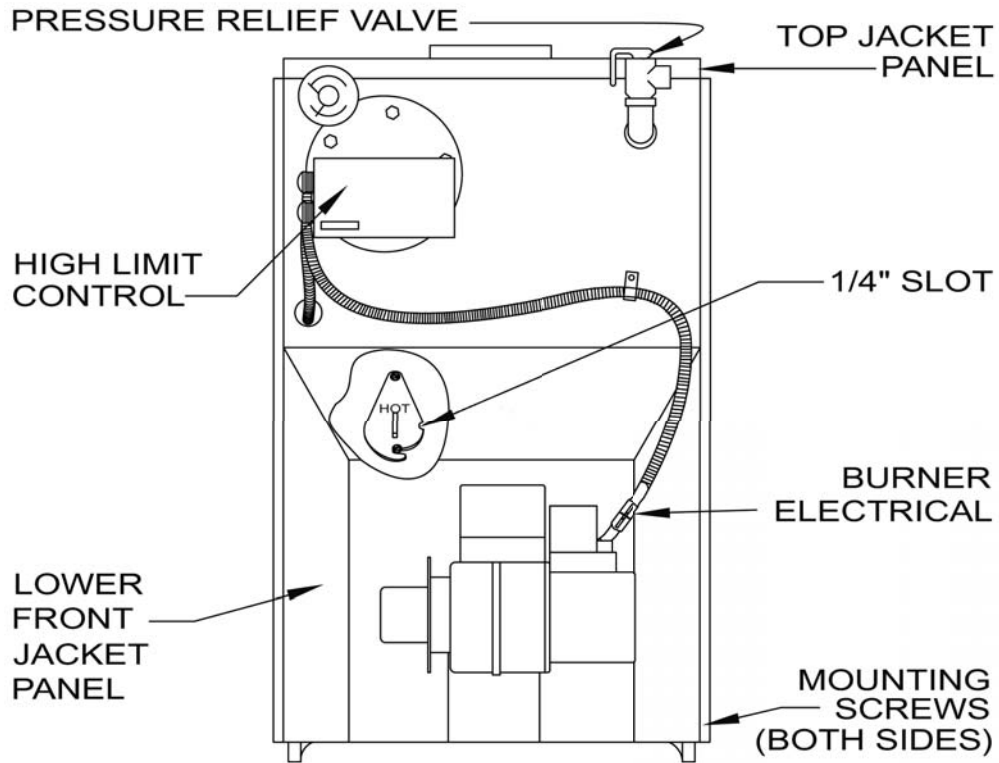

**Instructions For Closing Burner Swing Door**

1. Swing burner and door to right until insulation is slightly compressed and stud is exposed.
2. Attach nut to the stud and tighten it until the built in stop contacts the mounting door.
3. Replace oil line to burner.
4. Replace lower jacket panel, and tighten screws.
5. Connect power cable at factory supplied burner electrical disconnect.
6. Turn on power to boiler.
7. Bleed oil line.

## SERVICE CHECK LIST AND RECORD CHART

- |   |   |
|---|---|
| <input type="checkbox"/> Inspect Chimney and Flue pipe<br><input type="checkbox"/> Inspect and Clean Appliance<br><input type="checkbox"/> Inspect Oil Line - Size/Leaks<br><input type="checkbox"/> Inspect Electrical Connections<br><input type="checkbox"/> Install New Filter<br><input type="checkbox"/> Room Make-up Air<br><input type="checkbox"/> Electrode setting<br><input type="checkbox"/> *Nozzle-Size, Angle, Type | <input type="checkbox"/> *Pump Pressure/Vacuum<br><input type="checkbox"/> *Line Voltage/Motor Amps<br><input type="checkbox"/> *Smoke Test<br><input type="checkbox"/> *Draft Over-fire/In Flue<br><input type="checkbox"/> *CO <sub>2</sub> or O <sub>2</sub><br><input type="checkbox"/> *Flue Gas Temperature<br><input type="checkbox"/> Proper Light-Off (Hot & Cold)<br><input type="checkbox"/> Controls and Safety Devices |
|---|---|

\*Measure with Instruments and Record results on chart provided below

SERVICE RECORD CHART									
Date	Nozzle			Pump Pressure psi	Smoke #	Draft		CO <sub>2</sub> or O <sub>2</sub>	Flue Temperature F°
	Size	Angle	Type			O.F.	NF		

## REPLACEMENT PARTS

### HEAT EXCHANGER

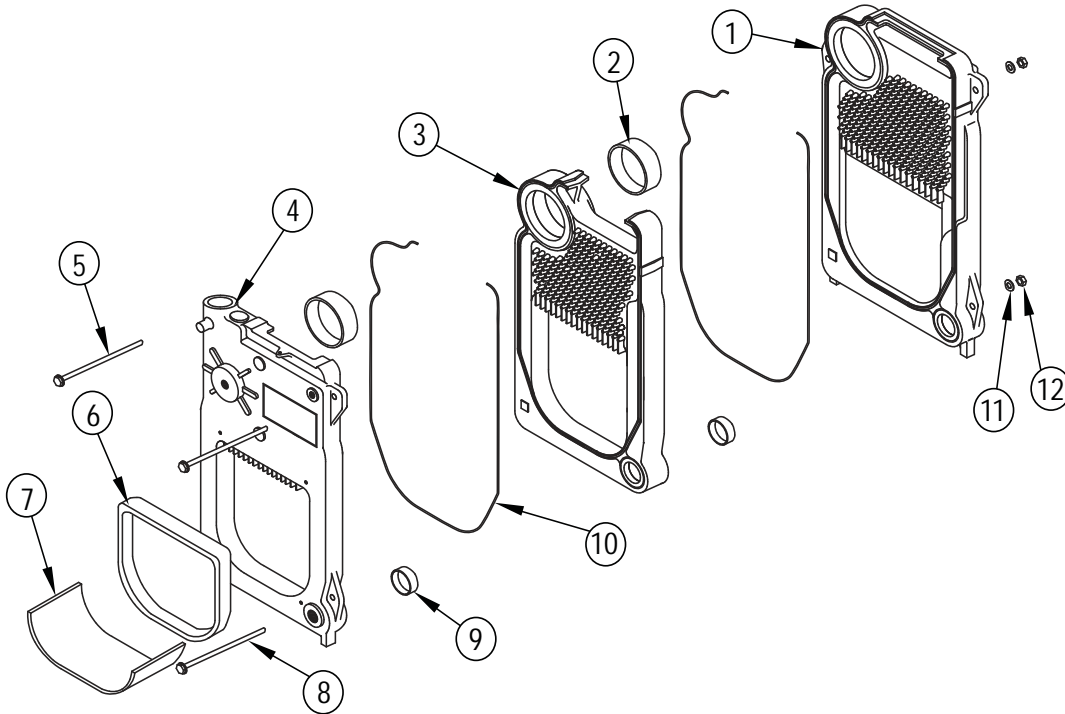

FULLY ASSEMBLED HEAT EXCHANGERS	
10023101	3 SECT. TNKLS W/O COIL
10023102	4 SECT. TNKLS W/O COIL
10023103	5 SECT. TNKLS W/O COIL
10023104	6 SECT. TNKLS W/O COIL
10023105	7 SECT. TNKLS W/O COIL
10023201	3 SECT. WITH TANKLESS COIL
10023202	4 SECT. WITH TANKLESS COIL
10023203	5 SECT. WITH TANKLESS COIL
10023204	6 SECT. WITH TANKLESS COIL
10023205	7 SECT. WITH TANKLESS COIL
10023301	3 SEC. WITH CAST OVER
10023302	4 SEC. WITH CAST OVER
10023303	5 SEC. WITH CAST OVER
10023304	6 SEC. WITH CAST OVER
10023305	7 SEC. WITH CAST OVER

ITEM #	PART #	DESCRIPTION	QTY
1	10051701	REAR SECTION	1
2	100-1-8.01	#60 PUSH NIPPLE	
		3 SECTION	2
		4 SECTION	3
		5 SECTION	4
		6 SECTION	5
		7 SECTION	6
3	10051101	CENTER SECTION	
		3 SECTION	1
		4 SECTION	2
		5 SECTION	3
		6 SECTION	4
4	10051801	FRONT SECT. CASTOVER	1
	10051301	FRONT SECT. TANKLESS COIL	
5	HW02510	TIE ROD 1/2 X 10 5/8 (3 SEC)	2
	HW02511	TIE ROD 1/2 X 14 1/4 (4 SEC)	
	HW02512	TIE ROD 1/2 X 17 7/8 (5 SEC)	
	HW02514	TIE ROD 1/2 X 21 3/4 (6 SEC)	
	HW02515	TIE ROD 1/2 X 25 1/4 (7 SEC)	
6	5611508	KIT - TARGET WALL & INSULATION BLANKET	1
7	25511005	INSUL BLANKET 16X24 (6 & 7 SECTION)	1

ITEM #	PART #	DESCRIPTION	QTY
8	HW-025.01	TIE ROD 1/2 X 12 1/2 (4 SEC)	1
	HW-025.02	TIE ROD 1/2 X 16 1/2 (5 SEC)	
	HW-025.03	TIE ROD 1/2 X 20 1/2 (6 SEC)	
	HW-025.05	TIE ROD 1/2 X 9 (3 SEC)	
	HW-025.09	TIE ROD 1/2 X 23 1/2 (7 SEC)	
9	100-1-5.01	#22 PUSH NIPPLE	
		3 SECTION	2
		4 SECTION	3
		5 SECTION	4
		6 SECTION	5
		7 SECTION	6
10	MS-006.00	ROPE MED DENSITY	1
		3 SECTION (13')	
		4 SECTION (19.5')	
		5 SECTION (26')	
		6 SECTION (32.5')	
		7 SECTION (39')	
11	HW-008.03	WASHER 1/2 ID FLAT	3
12	HW-003.05	NUT 1/2-13 HEX HEAD	3

## REPLACEMENT PARTS

### COIL

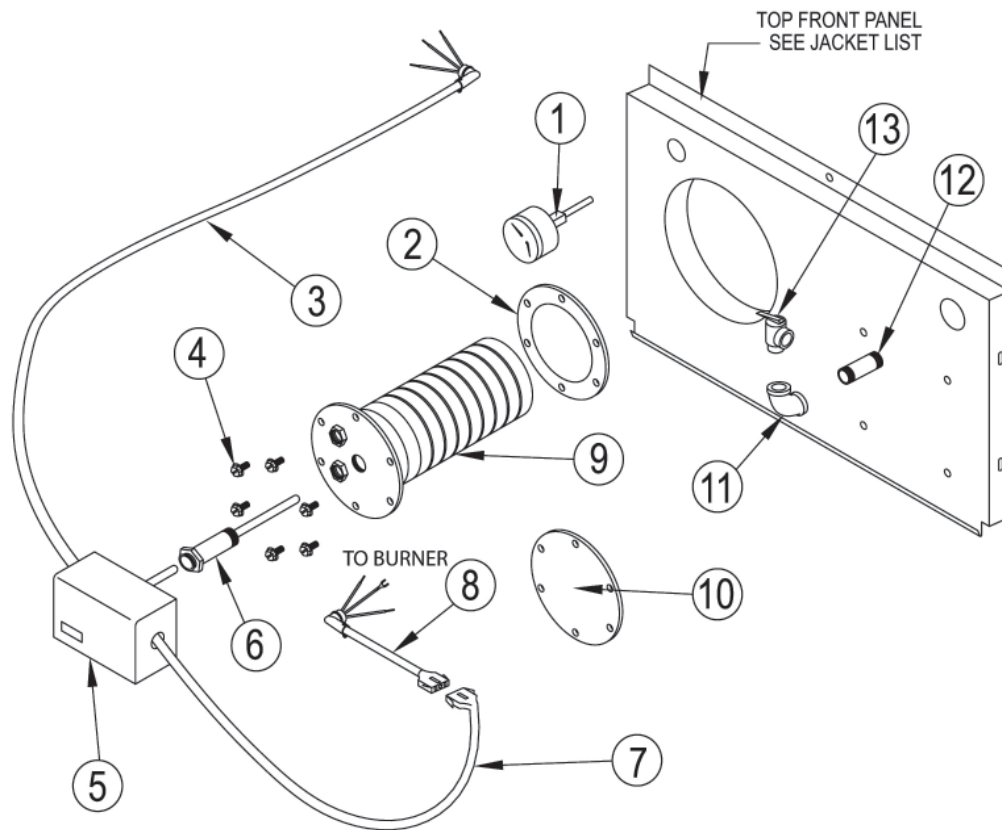

ITEM #	PART #	DESCRIPTION	QTY
1	GA-001.00	GAUGE THEALTIMETER, WATER	1
2	240007072	GASKET - SILICON/DURO 70	1
3	37519501	HARNES CIRCULATOR 72"	1
4	HW08001	BOLT 5/16" X 3/4"	6
5	1010001	CONTROL L8148A (FOR BOILERS WITHOUT A TANKLESS COIL)	1
	AQ-010.00	CONTROL L8124A (FOR BOILERS WITH A TANKLESS COIL)	1
6	AQ-020.01	WELL	1
7	2851401	HARNES CTRL BOX (BECKETT OR RIELLO)	1
	28511801	HARNES AQUASTAT (FOR CARLIN BUNERS ONLY)	
8	1263013	HARNES, BURNER (FOR BECKETT BURNERS ONLY)	1
	1263011	HARNES, BURNER (FOR RIELLO BURNERS ONLY)	
	28511901	HARNES, BURNER (FOR CARLIN BURNERS ONLY)	
9	5612001	TANKLESS COIL KIT P3 (FOR 3 SECTION BOILERS)	1
	5612002	TANKLESS COIL KIT T4 (4, 5, 6 & 7 SECT. BOILERS)	
<b>(ABOVE KITS INCLUDE ITEM NOS. 2, 4 AND THE APPROPRIATE COIL)</b>			
10	27511401	TANKLESS - COVER KIT	1
		(KIT INCLUDES ITEM NOS. 2, 4 AND COVER PLATE)	
11	1190001	PIPE FIT ELBOW 3/4" NPT	1
12	PF-005.11	PIPE FIT - NPL 3/4" X 4" NPT	1
13	VR-001.01	RELIEF VALVE 30#	1
NOT SHOWN	550001908	GASKET REPLACEMENT KIT (INCLUDES ITEMS #2 & #4)	1



REPLACEMENT PARTS

SWING DOOR AND MOUNTING DOOR COMPONENTS

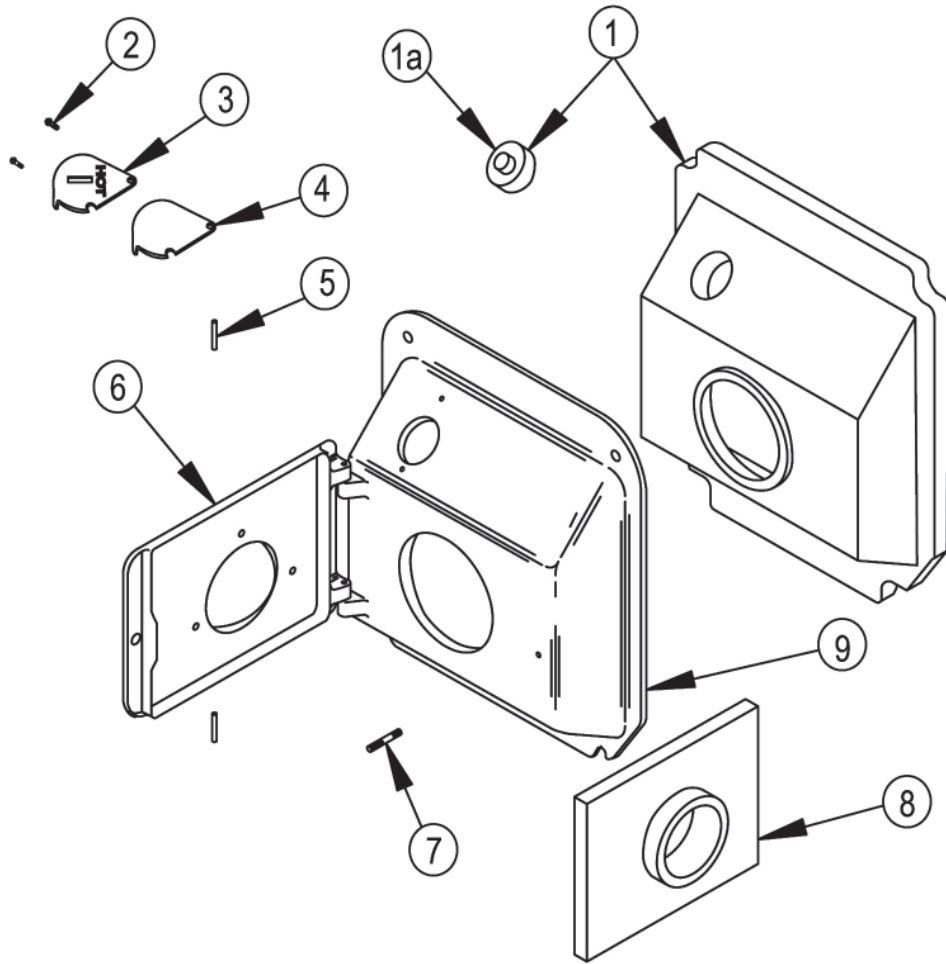

ITEM #	PART #	DESCRIPTION	QTY
1	2552901	MOUNTING DOOR INSULATION & PLUG	1
2	HW-005.01	SCREW 1/4-20X1/2 SELF TAPPING	2
3	10011701	OBSERVATION DOOR	1
4	25511101	OBS. DOOR GASKET	1
5	HW06801	1/4X1.3/4 DRIVE LOCK PIN	2
6	10011501	SWING DOOR	1
7	HW06701	5/16X18X2.3/8 STUD	1
8	2553301	INSULATION-SWING DOOR (FOR BOILERS WITH RIELLO BURNERS ONLY)	1
	2553303	INSULATION-SWING DOOR (FOR BOILERS WITH BECKET OR CARLIN BURNERS)	
9	10011301	MOUNTING DOOR	1

REPLACEMENT PARTS

JACKET

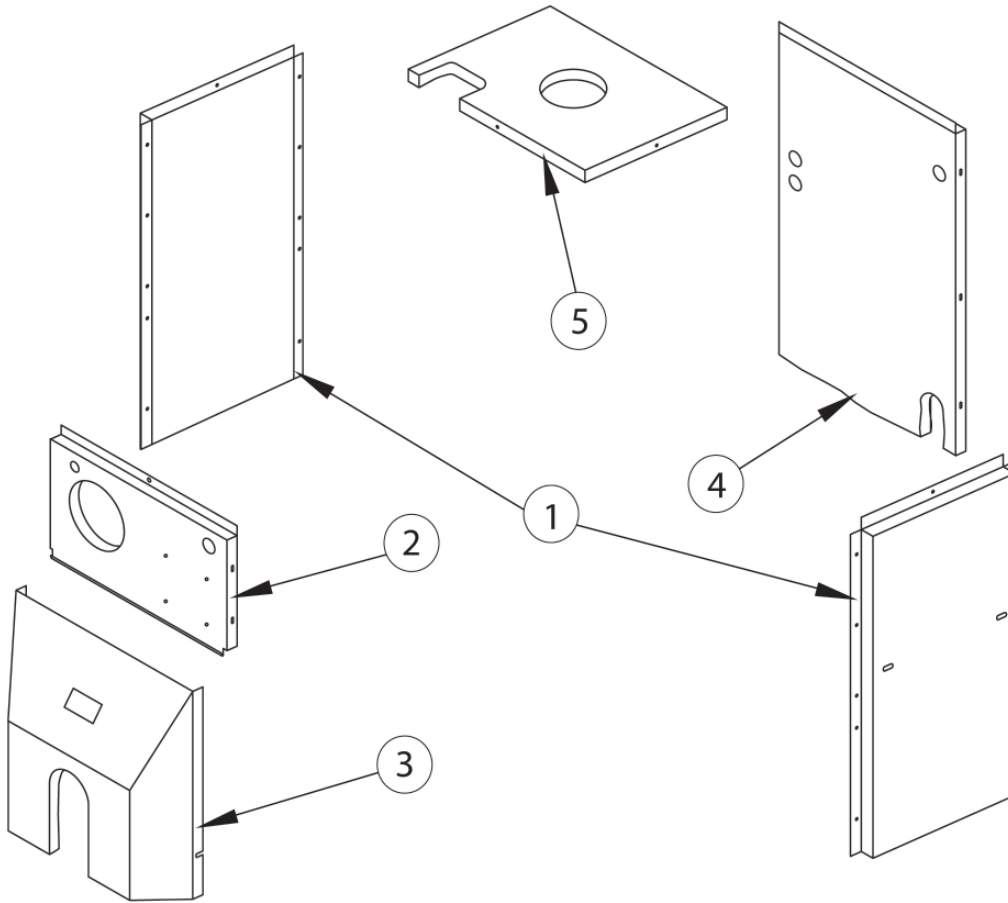

ITEM #	PART #	DESCRIPTION	QTY
1	21521802	SIDE PANEL 3 SECTION	2
	21521803	SIDE PANEL 4 SECTION	
	21521804	SIDE PANEL 5 SECTION	
	21521805	SIDE PANEL 6 SECTION	
	21521806	SIDE PANEL 7 SECTION	
2	21522401	TOP FRONT PANEL C/O	1
	21522402	TOP FRONT PANEL TNKLS COIL (SHOWN)	
3	21521901	LOWER COWL	1
4	21521501	REAR PANEL	1
5	215-1-3.02	TOP PANEL 3 SECTION	1
	215-1-3.03	TOP PANEL 4 SECTION	
	215-1-3.04	TOP PANEL 5 SECTION	
	2151307	TOP PANEL 6 SECTION	
	2151308	TOP PANEL 7 SECTION	

## REPLACEMENT PARTS

### HARDWARE

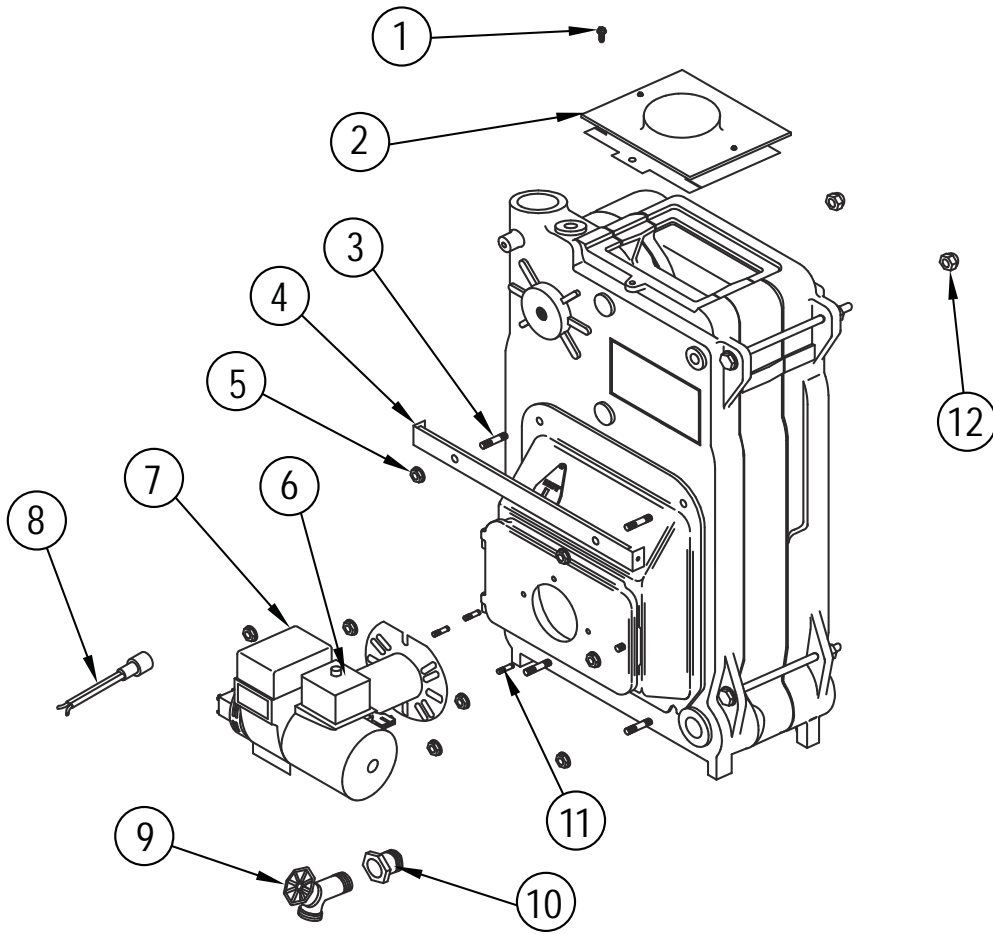

ITEM #	PART #	DESCRIPTION	QTY
1	HW-005.01	SCREW 1/4-20X1/2 SELF TAP	1
2	2452902	FLUE COLLECTOR ASSY (4 SECT)	1
	2452903	FLUE COLLECTOR ASSY (5 SECT)	
	2452906	FLUE COLLECTOR ASSY (3 SECT)	
	2452907	FLUE COLLECTOR ASSY (6 SECT)	
	2452908	FLUE COLLECTOR ASSY (7 SECT)	
3	HW06701	STUD 5/16"-18 X 2.3/8"	4
4	2252501	SUPPORT JACKET BRACKET	1
5	HW06901	NUT 5/16-18 WISLOCK	8
6	HW07001	STUD 5/16"-18 X 1.1/8"	3
7	HW-016.02	DRAIN LONG	1
8	1060003	PIPE FIT BUSHING 1.1/4" X 3/4"	
9	HW06401	NUT - ACORN 1/2"-13 UNC YELLOW	2

**REPLACEMENT PARTS**

**BURNER COMPONENTS**

<b>ITEM #</b>	<b>PART #</b>	<b>DESCRIPTION</b>	<b>QTY</b>
1	BN04001	BURNER OIL UT901C BECKETT (365)	1
	BN04002	BURNER OIL UT902C BECKETT (3100,&4100)	
	BN04004	BURNER OIL UT904C BECKETT (4125, 4150, & 5125)	
	BN04006	BURNER OIL UT906C BECKETT (5200, & 5175)	
	BN08901	BURNER OIL UT1801 BECKETT (6225 & 7275)	
	BN06003	BURNER OIL UT1103C BECKETT (3125)	
	30A064201	BURNER OIL RIELLO 40/F3 (365)	
	1050006	BURNER OIL RIELLO 40/F5 (3100, 4100, 4125, 4150, & 5125)	
	BN07007	BURNER OIL RIELLO 40/F10 (5175 & 5200)	
	BN08401	BURNER OIL CARLIN EZ-1 (365, 3100, & 4100)	
	BN08402	BURNER OIL CARLIN EZ-1 (4125, 4150, & 5125)	
	BN08403	BURNER OIL CARLIN EZ-2 (5175, & 5200)	
2	BN08001	BURNER OIL FLANGE GASKET #3616	1
	30A055901	GASKET OB MT FLG #3416	1
3	CD-001.01	CAD CELL (FOR BOILERS WITH BECKETT OR CARLIN BURNERS ONLY)	1
4	RY-001.01	CONTROL R8184G (CONTROL FOR BOILERS WITHOUT COIL) (FOR BOILERS WITH CARLIN BURNERS ONLY)	1
	RY-001.02	CONTROL R4184D (TANKLESS COIL CONTROL) (FOR BOILERS WITH CARLIN BURNERS ONLY)	
	RY00701	CONTROL R7184B 1032 (7456U) (FOR BOILERS WITH BECKETT BURNERS ONLY)	
5	1320003	NOZZLE .60 80B (365 BECKETT)	1
	1320004	NOZZLE .85 80B (3100 & 4100 BECKETT)	
	NZ-002.08	NOZZLE 1.10 80B (4125 & 5125 BECKETT)	
	NZ-002.10	NOZZLE 1.25 80B (4150 BECKETT)	
	NZ-002.12	NOZZLE 1.50 80B (5175 BECKETT)	
	NZ00206	NOZZLE 1.75 80B (5200 BECKETT)	
	NZ01201	NOZZLE 2.00 45B (6225 BECKETT)	
	14619346	NOZZLE 2.25 45B (7275 BECKETT)	
	NZ00801	NOZZLE .65 80W (365 RIELLO)	
	NZ00802	NOZZLE .85 80W (3100 & 4100 RIELLO)	
	1320012	NOZZLE 1.10 60W (3125, 4125, & 5125 RIELLO)	
	1320013	NOZZLE 1.25 60W (4150 RIELLO)	
	NZ-002.12	NOZZLE 1.50 80B (5175 RIELLO)	
	NZ00206	NOZZLE 1.75 80B (5200 RIELLO)	
	NZ00901	NOZZLE .60 70B (365 CARLIN)	
	NZ00902	NOZZLE .85 70B (3100, & 4100 CARLIN)	
	NZ00903	NOZZLE 1.10 70B (4125, & 5125 CARLIN)	
	NZ00904	NOZZLE 1.25 70B (4150 CARLIN)	
NZ00905	NOZZLE 1.75 70B (5200 CARLIN)		
NZ00906	NOZZLE 1.50 70B (5175 CARLIN)		

**REPLACEMENT PARTS**

**BURNER COMPONENTS**

<b>BECKETT AFG BURNER PARTS</b>		
<b>(USED ON ALL BOILER MODELS WITH BECKETT BURNERS EXCEPT 3125, 6225, AND 7275)</b>		
<b>ITEM #</b>	<b>PART #</b>	<b>DESCRIPTION</b>
1	RP03801	BLAST TUBE AFG/
2	RP03701	FUEL PUMP, 1 STAGE, 140 PSI, AFG
	RP03702	FUEL PUMP, 2 STAGE, 140 PSI, AFG
3	BN07102	DRAWER ASSEMBLY (OIL LINE), AFG
4	BN08001	BURNER GASKET
5	RP-015.00	MOTOR
6	1050007	TRANSFORMER
<b>BECKETT AFII BURNER PARTS</b>		
<b>(USED ON MODEL 3125 ONLY)</b>		
<b>ITEM #</b>	<b>PART #</b>	<b>DESCRIPTION</b>
1	RP03802	BLAST TUBE AF2
2	RP03901	FUEL PUMP AF2 DANFOSS
3	RP04001	7" DRAWER ASSY AF2
4	RP04101	OIL BRN TRANSFORMER AF2
5	RP04201	OIL BRN MOTOR AF2
<b>BECKETT CF375 BURNER PARTS</b>		
<b>(USED ON MODELS 6225 &amp; 7275)</b>		
<b>ITEM #</b>	<b>PART #</b>	<b>DESCRIPTION</b>
1	RP04501	FUEL PUMP, CLEAN CUT (21844U)
2	RP-015.00	MOTOR, PSC (21805U)
3	1050007	TRANSFORMER, (51771U)
4	RP04601	OIL BURNER VALVE COIL KIT (21755U)

**REPLACEMENT PARTS****BURNER COMPONENTS****CARLIN BURNER PARTS**

<b>CARLIN BURNER PARTS</b>		
<b>ITEM #</b>	<b>PART #</b>	<b>DESCRIPTION</b>
1	BN08601	BRN HEAD BAR .6-.65 365
	BN08602	BRN HEAD BAR .85-1 3100 & 4100
	BN08603	BRN HEAD BAR 1.1-1.25 4125, 4150, & 5125
	BN08604	BRN HEAD BAR 1.65-1.75 C5175 & 5200

**RIELLO BURNER PARTS**

<b>RIELLO BURNER PARTS</b>		
<b>ITEM #</b>	<b>PART #</b>	<b>DESCRIPTION</b>
1	30A064701	BRN PUMP DRIVE KEY RIELLO
2	30A064801	BRN PRIMARY CTRL-530SE RIELLO
3	30A064901	BRN COIL RIELLO
4	30A065101	BRN MOTOR RIELLO
5	30A065201	BRN CAPACITOR 12.5uF RIELLO
6	30A065301	BRN ELECTRODE PORCELAIN RIELLO
7	30A065401	BRN PUMP RIELLO
8	30A065501	BRN HYDRAULIC JACK RIELLO
9	30A065601	BRN O-RING PUMP PRESS RIELLO
10	30A065701	BRN PHOTO CELL RIELLO





---

**Columbia Company**  
Main offices and factory  
Pittstown, PA