



SW

OIL FIRED DIRECT EXHAUST CAST IRON BOILER

INSTALLATION, OPERATION & MAINTENANCE MANUAL



An ISO 9001-2008 Certified Company

Utica Boilers

2210 Dwyer Avenue, Utica NY 13504-4729

Phone: (315) 797-1310 • Fax: (866) 432-7329

e-mail: info@ecrinternational.com

web site: www.ecrinternational.com

P/N# 27515401, Rev. A [03/2011]

TABLE OF CONTENTS

Safety Symbols 3
Installation 4
Connecting Supply And Return Piping 5
Recommended Piping For Boilers Equipped With A P3 Or T4 Tankless Heater..... 9
Options Utilizing 3/4" Tapping10
Oil Tank And Piping11
Electrical Wiring12
Thermostat Installation13
Normal Sequence Of Operation.....14
Operating Instructions.....14
Instructions To Obtain Proper Operation Of The Boiler-Burner Unit15
Preventive Maintenance.....16
Instructions For Opening And Closing Burner Swing Door16
Service Check List17
Sw Series Replacement Parts18
Dimensions.....26

Read All Instructions Before Installing.



Tested For 75 psig.
ASME Working Pressure

Safety Symbols

The following defined symbols are used throughout this manual to notify the reader of potential hazards of varying risk levels.

DANGER

Indicates a hazardous situation which, if not avoided, **WILL** result in death or serious injury.

CAUTION

Indicates a hazardous situation which, if not avoided, may result in minor or moderate injury.

WARNING

Indicates a hazardous situation which, if not avoided, could result in death or serious injury.

NOTICE

Indicates information which should be followed to ensure proper installation and operation.

WARNING

Boiler and venting installations should be done only by a qualified expert and in accordance with the appropriate Utica Boilers Installation, Operation and Maintenance manual.

Installing or venting a boiler or any other gas appliance with improper methods or materials may result in serious injury or death due to fire or to asphyxiation from poisonous gases such as carbon monoxide which is odorless and invisible.

WARNING

- Keep boiler area clear and free from combustible materials, gasoline and other flammable vapors and liquids.
- **DO NOT** obstruct air openings to boiler room.
- Modification, substitution or elimination of factory equipped, supplied or specified components may result in property damage, personal injury or the loss of life.

NOTICE

- **To the owner:** Installation and service of this boiler must be performed by a qualified installer.
- **To the installer:** Leave all instructions with the boiler for future reference.
- When this product is installed in the Commonwealth of Massachusetts installation must be performed by a Licensed Plumber or Licensed Gas Fitter.

INSTALLATION



WARNING

Improper installation, adjustment, alteration, service or maintenance could result in personal injury or loss of life.

Installation

Installation must conform to American Society of Mechanical Engineers Safety Code for Controls and Safety Devices for Automatically Fired Boilers, ANSI/ASME CSD-1. In Canada installations must be in accordance with CSA B139. In absence of such codes, installation must conform to the requirements of authority having jurisdiction. Such applicable requirements take precedence over general instructions of this manual.

Locate boiler in front of final position before removing crate. Provide level solid base as near to vent outlet as possible and centrally located with respect to heat distribution system as practical.

Allow 24 inches in front and top for servicing and cleaning, or removing tankless water heating coil.

When installed in utility room, door should be wide enough to allow largest boiler part to enter, or permit replacement of another appliance such as water heater.

Installation on Combustible Floors

Boiler shall not be installed directly on carpeting, tile or other combustible material other than wood flooring. Boiler must not be installed on carpeting or vinyl flooring.

Minimum clearances to combustible construction are:

TOP	0.0 IN.
FRONT	24.0 IN.*
FLUE CONNECTOR	2.0 IN.
REAR	0.0 IN.
LEFT SIDE	0.0 IN.
RIGHT SIDE.....	0.0 IN.

* "FOR ALCOVE INSTALLATION"

Recommended clearance for service access should exceed fire protection clearance.

TOP	24 IN.
FRONT	24 IN.
FLUE CONNECTOR	9 IN.
REAR	6 IN.
LEFT SIDE	10 IN.
RIGHT SIDE.....	6 IN.

Remove crate and plastic protective wrapper and inspect for damage.

Our responsibility ceases upon delivery of the crated boiler to the carrier in good condition. Any claims for damage or shortage in shipment must be filed immediately against carrier by consignee. Move boiler to permanent position by sliding or walking.

NOTICE

Circulators in following illustrations are mounted on system supply side, mounting on system return side is also acceptable practice.

Figure 1 - Typical Installation Using Circulators

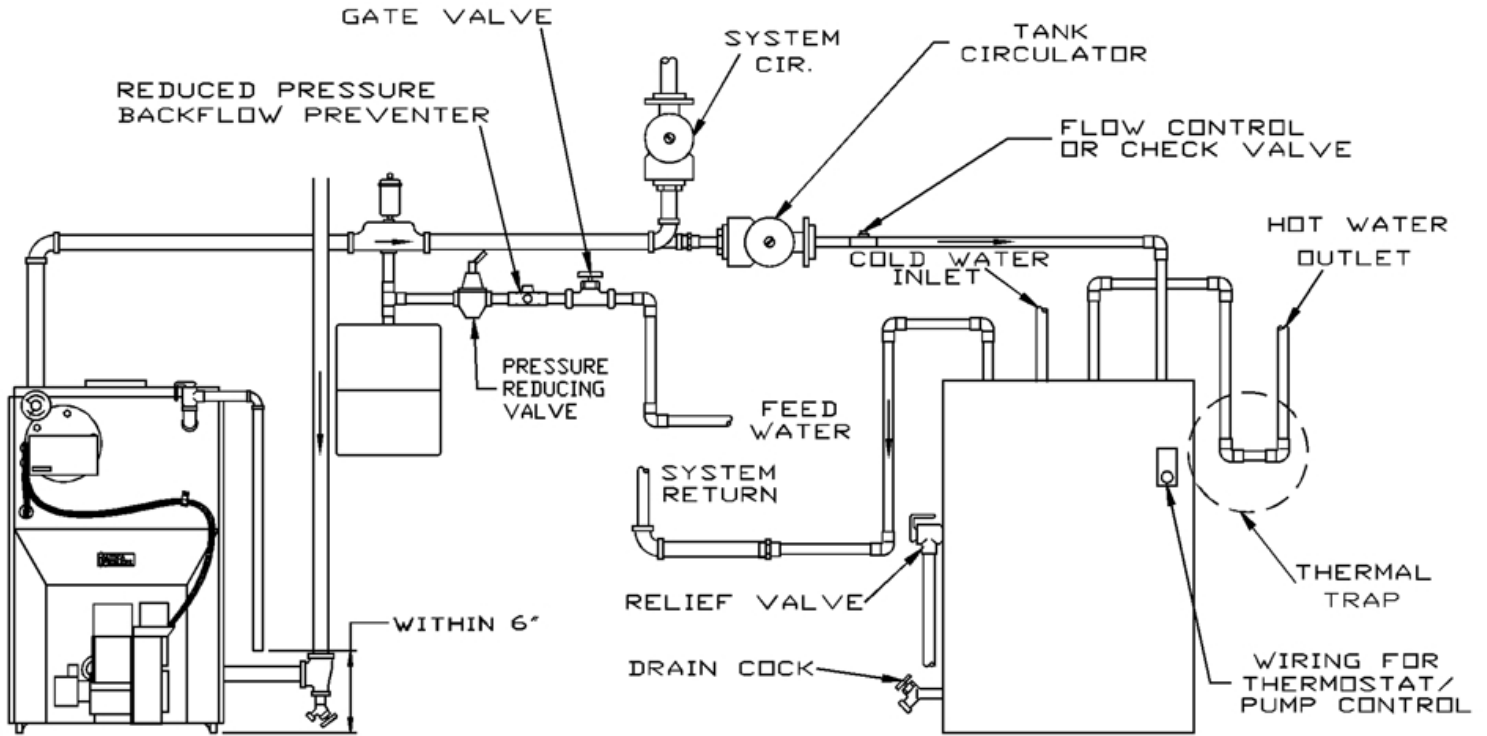
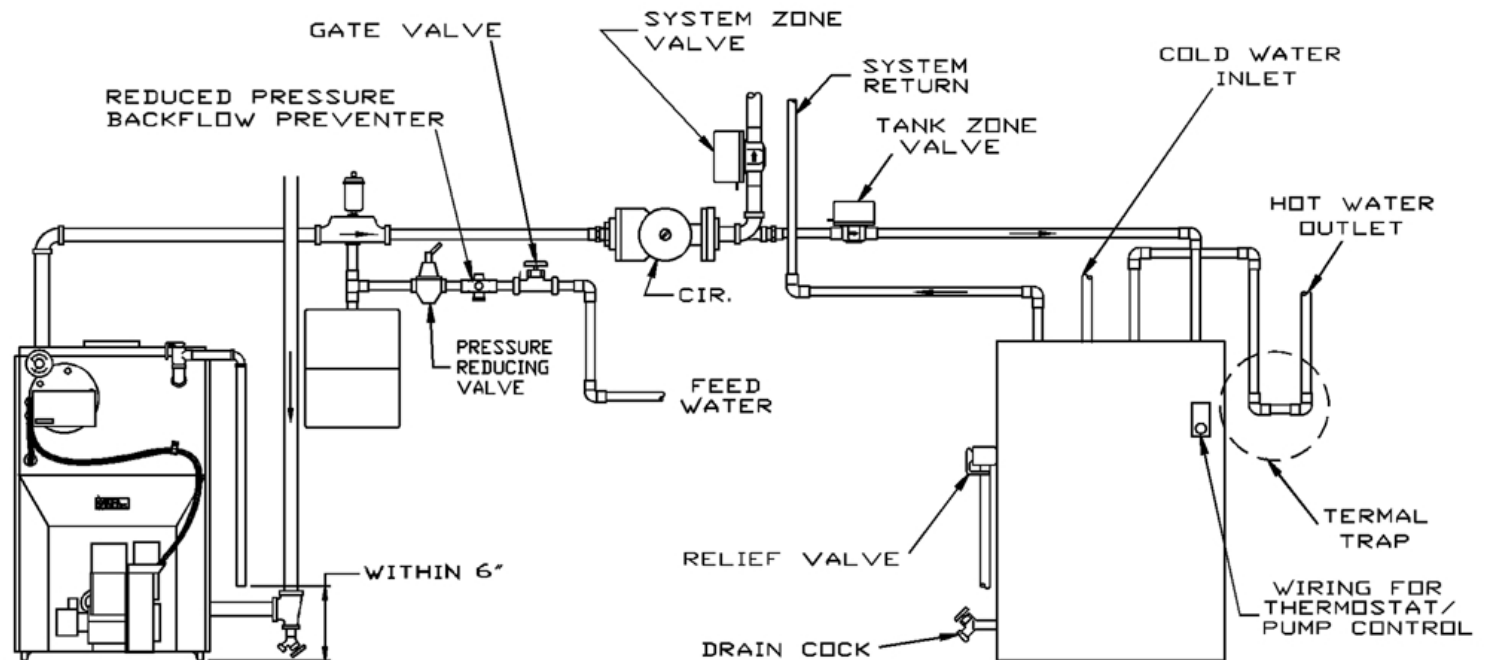

Figure 2 - Typical Installation Using Zone Valves



CONNECTING SUPPLY AND RETURN PIPING

1. Typical installation using circulators shown in **Figure 1**.
2. Typical installation using zone valves shown in **Figure 2**.
3. Hot water boilers installed above radiation level must be provided with low water device either as part of boiler or at time of boiler installation.
4. When boiler is connected to heating system utilizing multiple zoned circulators, each circulator must be supplied with flow control valve to prevent gravity circulation.
 - Reduced pressure back flow preventer must be present under provisions required by Environmental Protection Agency, (EPA).
5. Bypass piping is an option which gives ability to adjust supply boiler water temperature to fit system or condition of installation. This method of piping is not typically required for baseboard heating systems.
 - Method used to protect systems using radiant panels and material they are encased in from high temperature supply water from boiler. See **Figure 3**.
 - Method used to protect boilers from condensate forming due to low temperature return water. Generally noticed in large converted gravity systems or other large water volume systems. See **Figure 4**.
 - Method used to protect boilers from condensate forming as well as protecting heating system from high water temperature. See **Figure 5**.
6. When using bypass piping, adjust valves A and B until desired system temperature is obtained.
7. Bypass loop piping must be same size piping for supply and return.

Figure 3

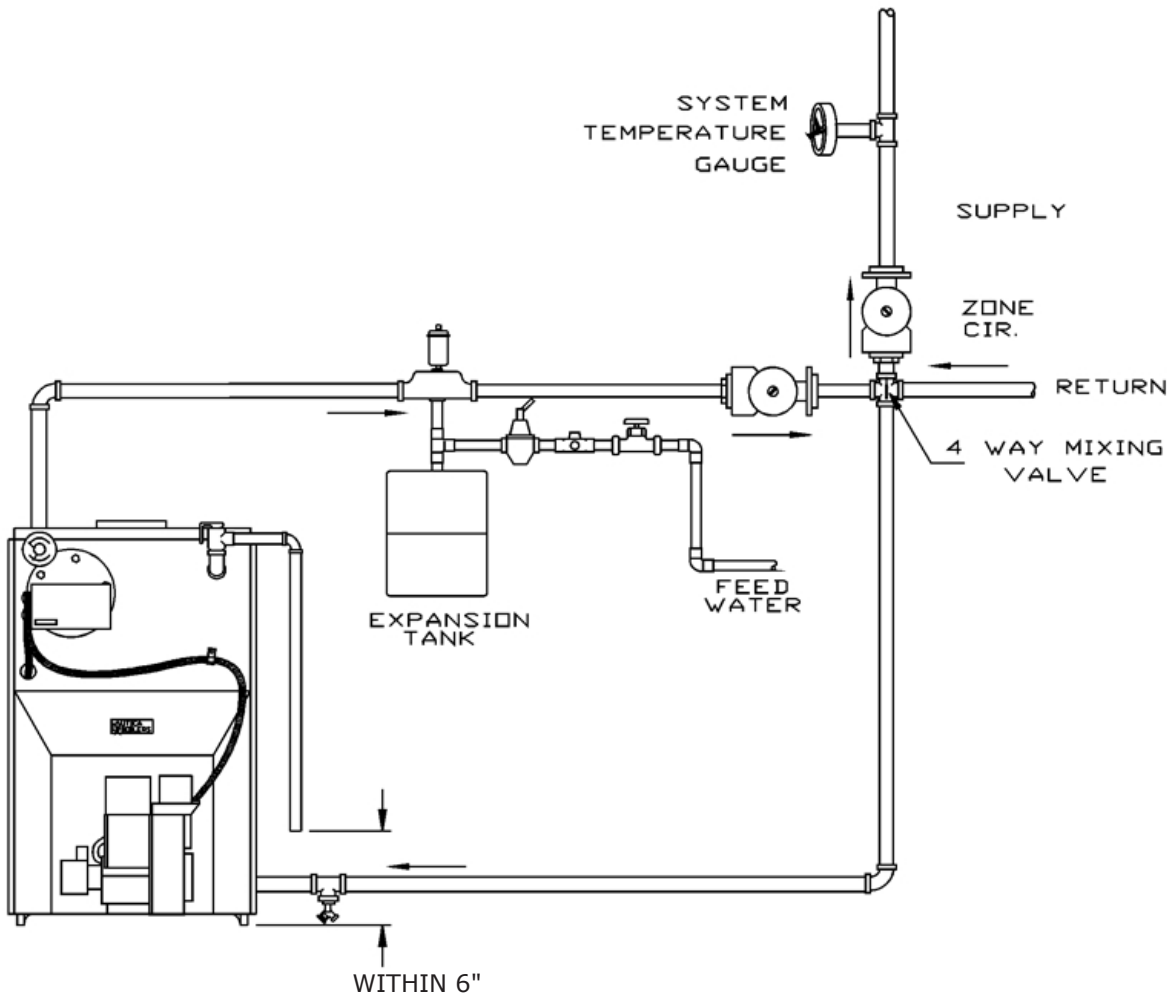

Figure 4

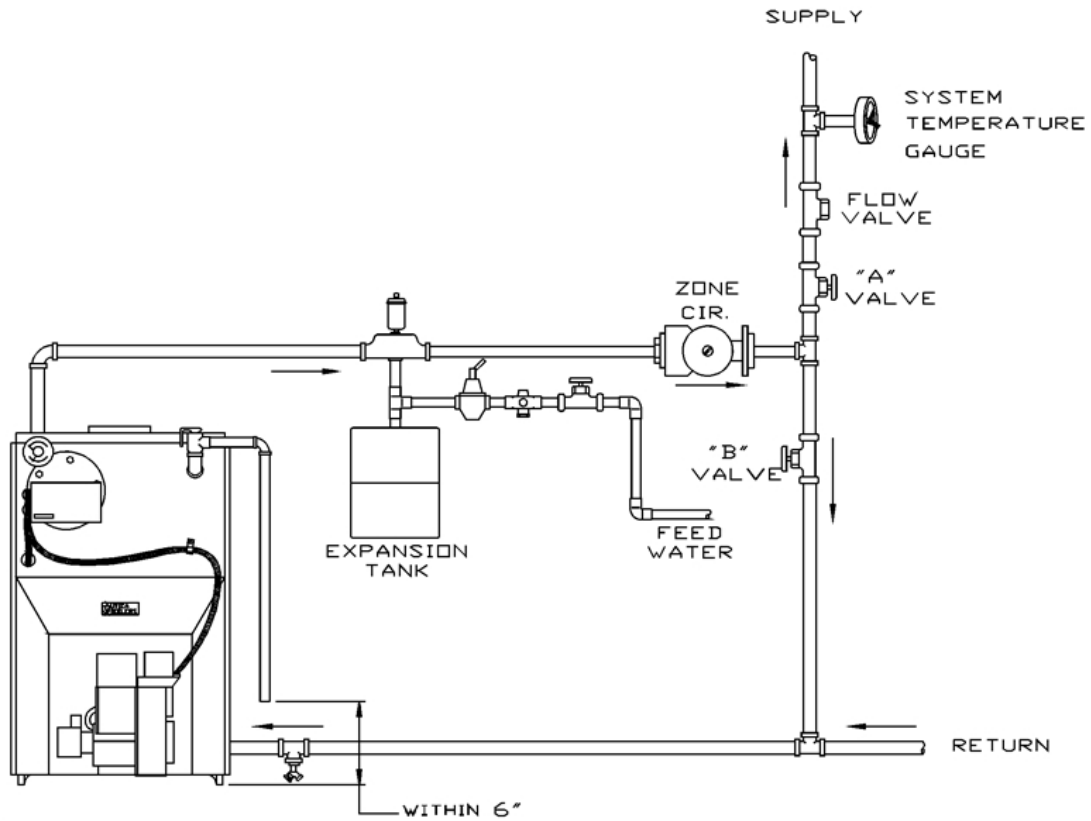
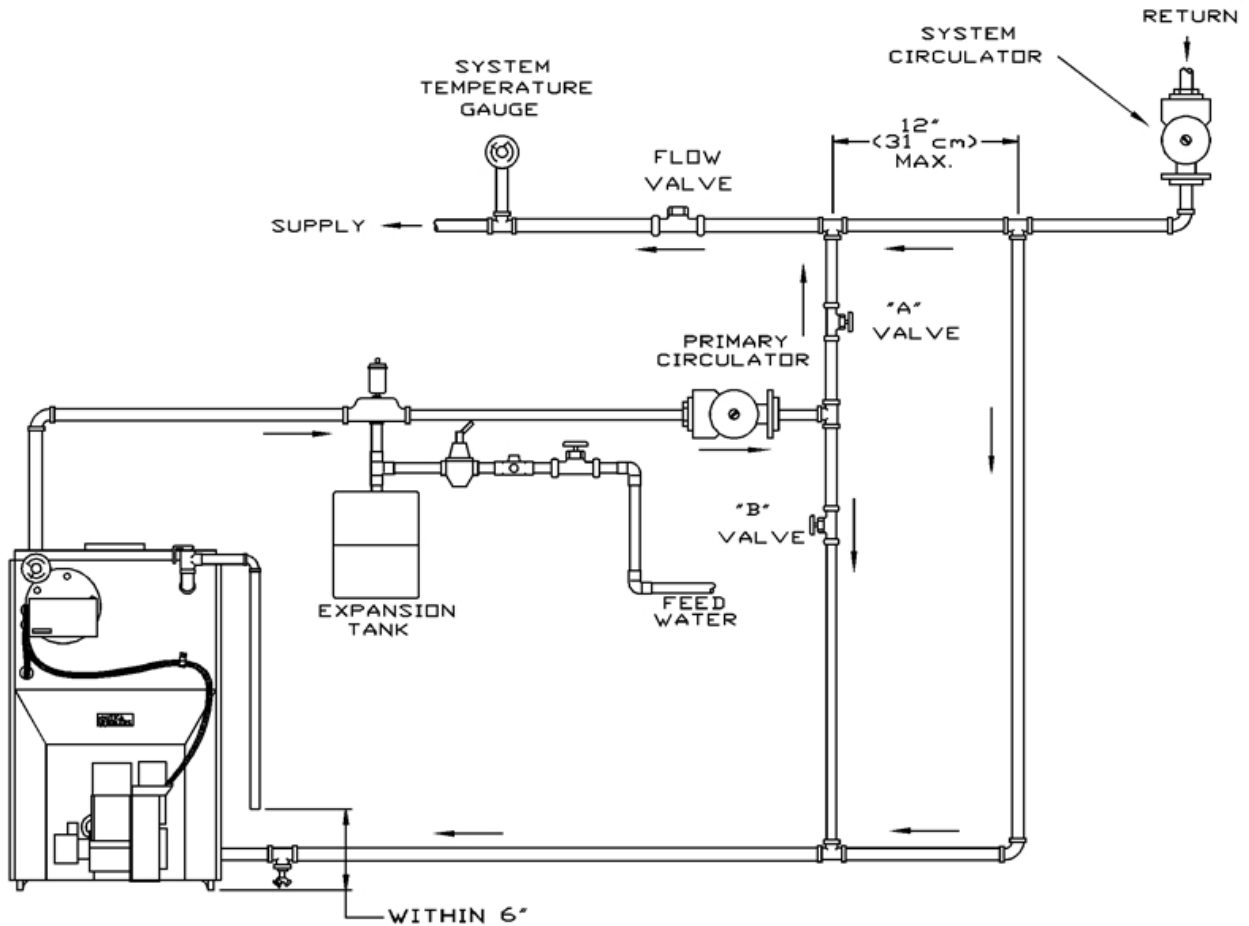

Figure 5



CONNECTING SUPPLY AND RETURN PIPING

8. Connect supply and return piping as suggested in **Figure 6**, when boiler is used in connection with refrigerated systems:
 - A. Chilled medium must be in parallel with the boiler.
 - B. Use appropriate valves to prevent chilled medium from entering heating boiler.
9. During heating cycle open valves A and B, close valves C and D.
10. During heating cooling cycle open valves C and D, close valves A and B.
 - A. Maintain minimum clearance of one inch to hot water pipes.
11. For further piping information refer to the I=B=R installation and piping guide.

Figure 6

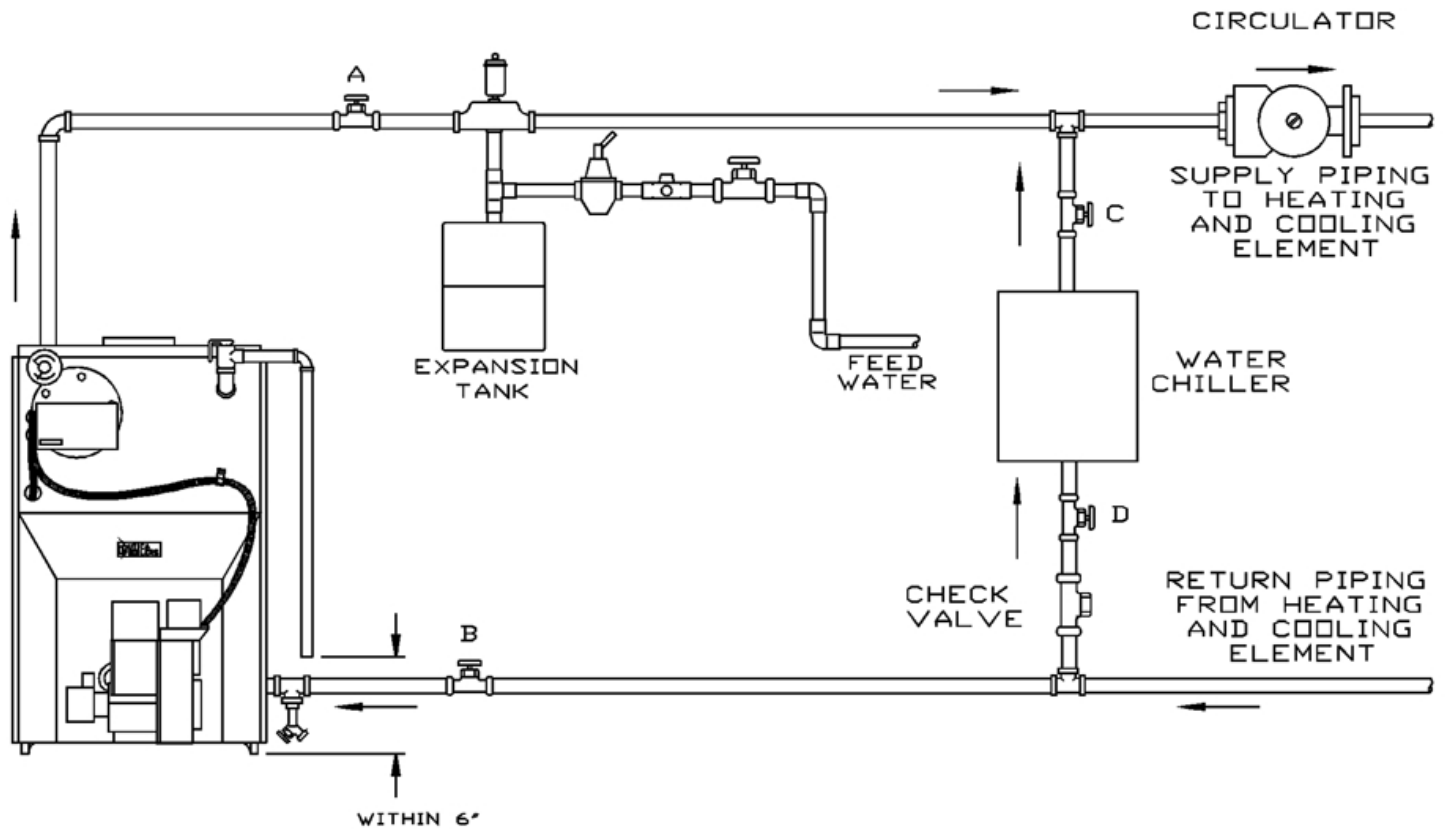

DANGER



Burn, scald hazard. Water temperatures exceeding 125° F will cause severe burns instantly or death by scalding.

- An automatic mixing valve must be installed on the outlet of the domestic coil. Installation must comply with the valve manufacturer's recommendations, and instructions.
- Do not remove the bolts or aquastat at the time of installation.
- Pipe in accordance with the installation manual.
- Due to varying water conditions, an adjustable flow restrictor must be installed in the cold water inlet of this coil.

Figure 7 Recommended Piping For Boilers Equipped With A P3 Or T4 Tankless Heater

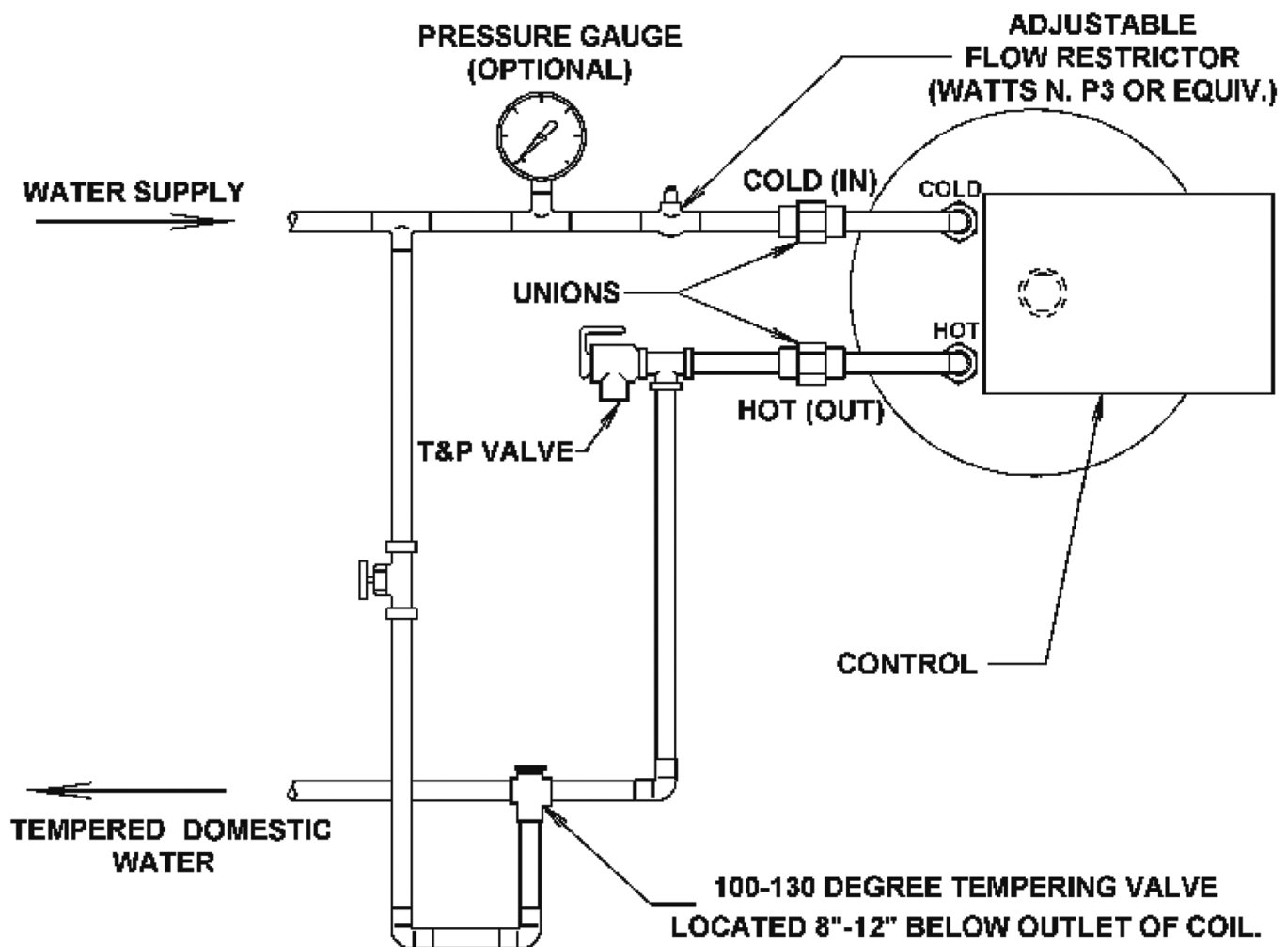

Figure 8 - Optional Location For Air Vent

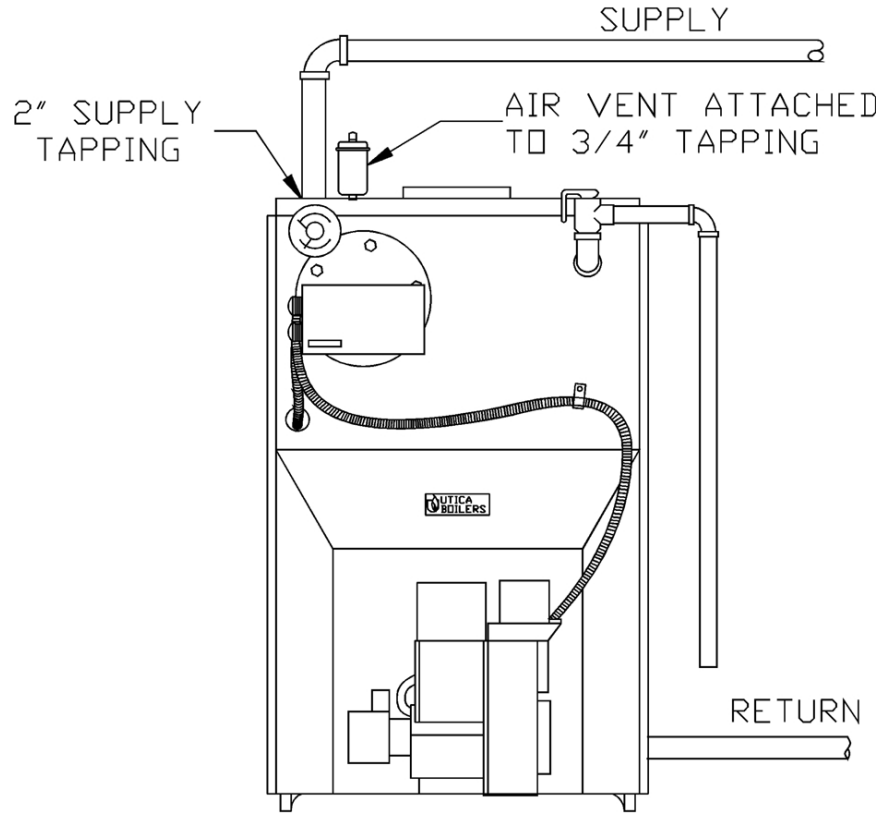
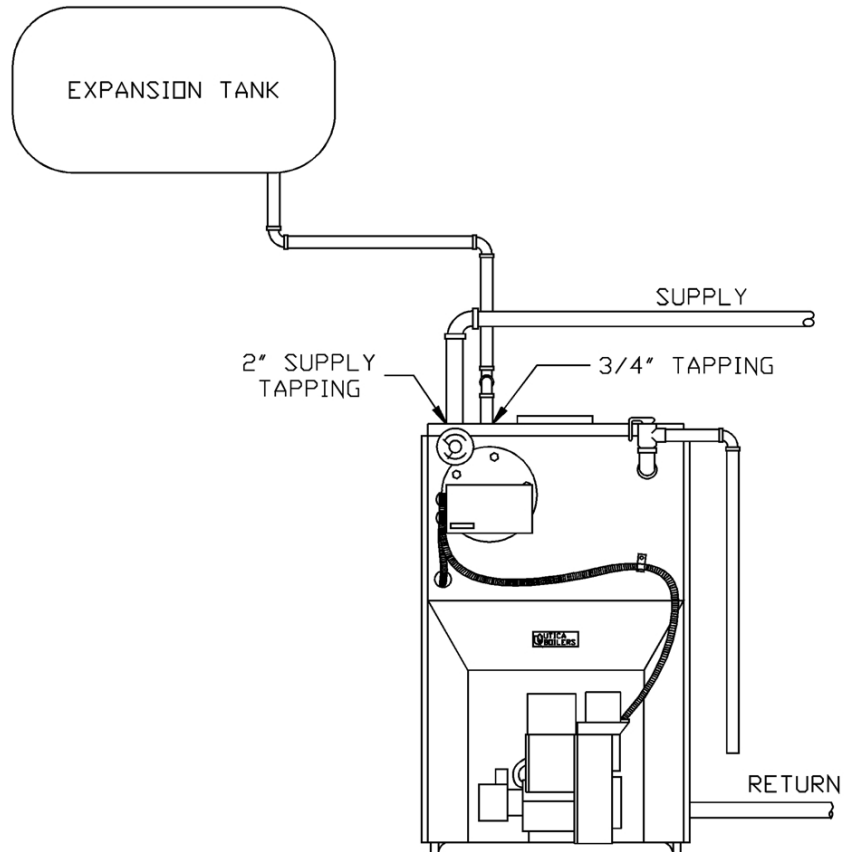

Figure 9 - Optional Location For Expansion Tank (Non-Diaphragm Type)



OIL TANK AND PIPING

Install Oil tank and piping in accordance with the National Board of Fire Underwriters and in absence of such regulations in accordance with authority having jurisdiction. Oil storage tank, vent, fill pipe and caps should be in accordance with the authority having jurisdiction.

- A. In no case should vent pipe be smaller than 1-1/4" I.P.S.
 - B. Fill pipe should not be less than 2" I.P.S.
- Suction line from tank to burner should be one continuous piece of tubing to prevent air entering line. Suction line, must be 3/8" O.D. copper tubing for runs of 50 feet or less, and 1/2" O.D. for longer runs.
 - Oil return line, same size as suction line, must be used on any installation where bottom of tank is below fuel unit of burner.
 - Oil lines should be buried or otherwise protected from mechanical injury.
 - Flare fittings on all oil lines are recommended.
 - Compression fittings on suction line often allow air to be drawn into fuel pump, making it difficult to maintain oil pressure at nozzle.

- Do not run overhead fuel lines from tank to oil burner.
- Fuel pump connections and by-pass should be made according to instructions attached to fuel pump. If tank is more than 20' from the boiler, a two stage fuel unit should be installed in place of single stage pump supplied as standard equipment with burner. Make certain rotation and speed are same and pump is suitable for burner horsepower rating.
- Oil line filter and shut-off valve should be installed in suction line.
- Shut-off valves should be installed in both suction and return lines at burner for convenience in servicing burner.
- Allow extra tubing at burner so burner may be removed from boiler for cleaning without disconnecting tubing. (See **Figures 10 & 11**).
- A UL approved flexible oil line may be used.

Figure 10 - Typical Installation Single Pipe Oil System

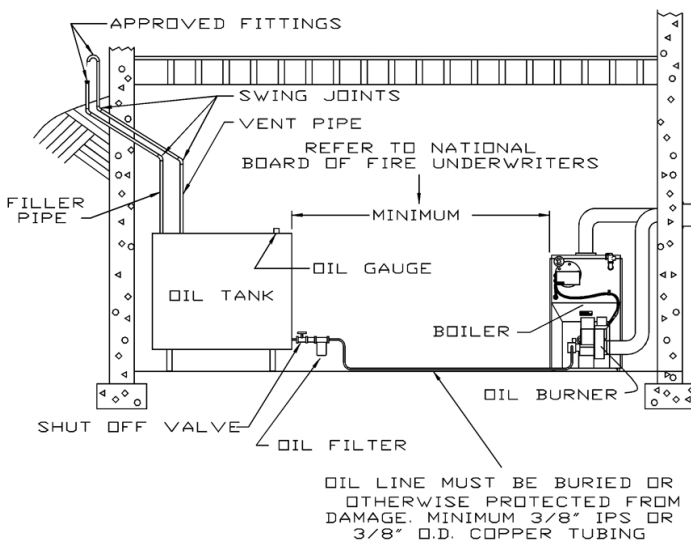
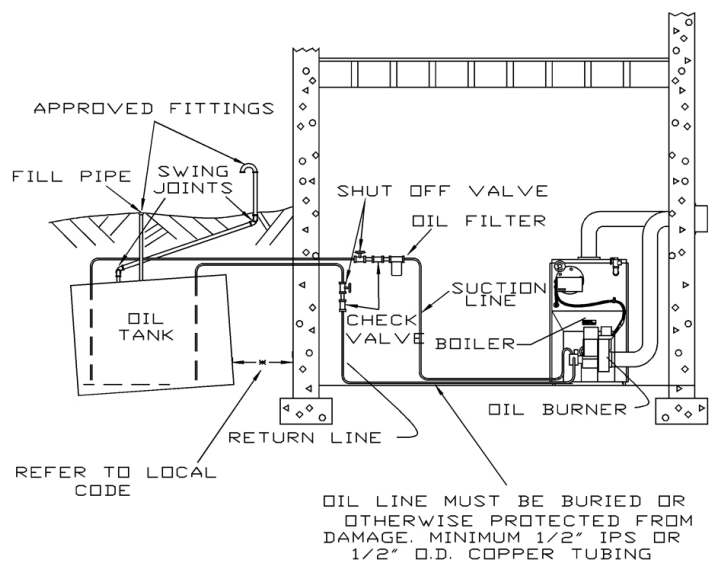

Figure 11 - Typical Installation Two Pipe Oil System



ELECTRICAL WIRING



Electrical wiring must conform with National Electrical Code ANSI/NFPA No. 70 in United States and CSA C22.1 Canadian Electrical Code in Canada and/or the local authority having jurisdiction.

- Separate electrical circuit should be run from entry box with fused disconnect switch in this circuit.
- See wiring diagrams in **Figures 12 & 13**, for suggested circuitry and field wiring see Normal Sequence of Operation in this manual.
- Wiring for zone valve installations are furnished with zone valve packages.

Wiring Code

	LINE VOLTAGE BY FACTORY
	LOW VOLTAGE BY FACTORY
	LINE VOLTAGE BY INSTALLER
	LOW VOLTAGE BY INSTALLER

Component Coding

TH-1	Thermostat (millivolt)
TH-2	Thermostat (24 Volt)
TH-3	Thermostat (Line Voltage)
TR-1	Transformer (120V/24V 40VA)
TR-2	Transformer (120V/24V 50VA)
LGV	24 Volt Gas Valve
PS	Pressure Switch
MR-PS	Manual Reset Pressure Sw.
	Control Terminal
1K	Relay Coil
1K1	Relay Contacts
1K2	Relay Contacts
LS	Limit Switch
MS	Manual Switch
CIR	Circulator
ECO	Energy Cut-Off
PSC	Pilot Safety Coil
	Wire Connection
LWCO	Low Water Cut Off
EFW	Electric Water Feeder
PG	Power Generator

* Not all components listed are used in all control systems.

Figure 12 - Wiring Diagram For Oil Fired Boilers Less Tankless Heater

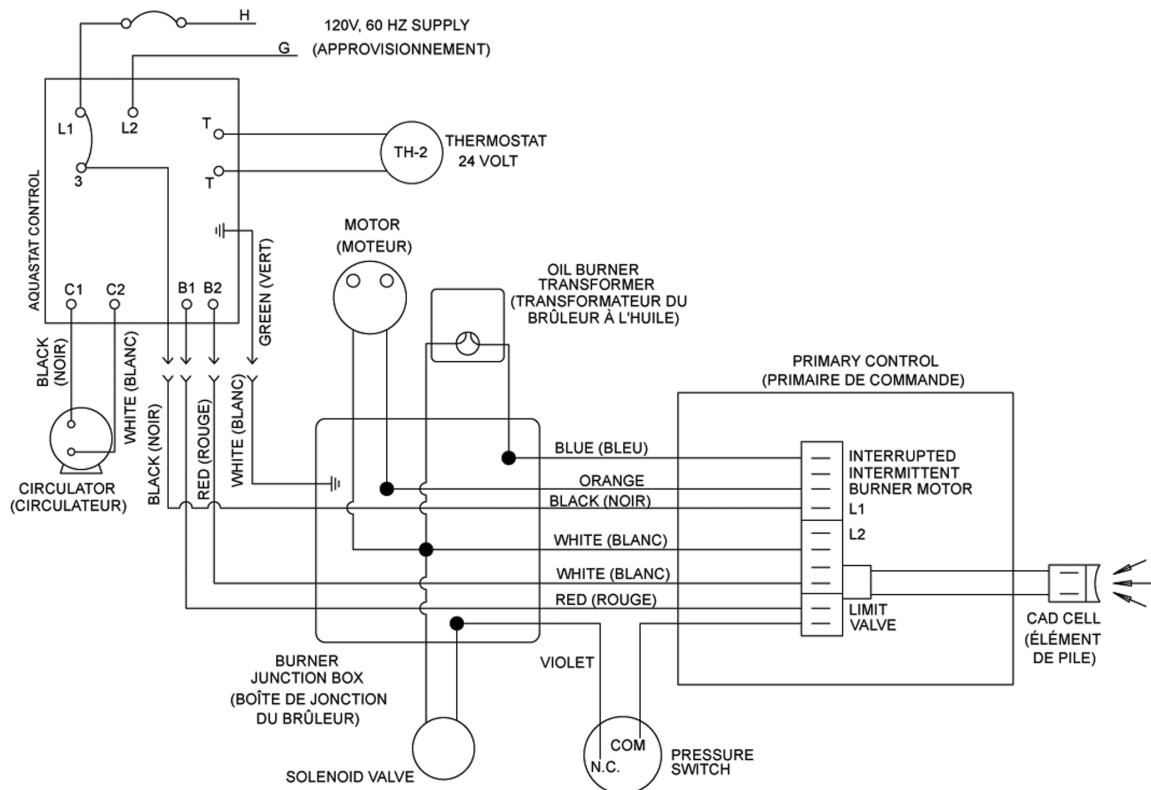
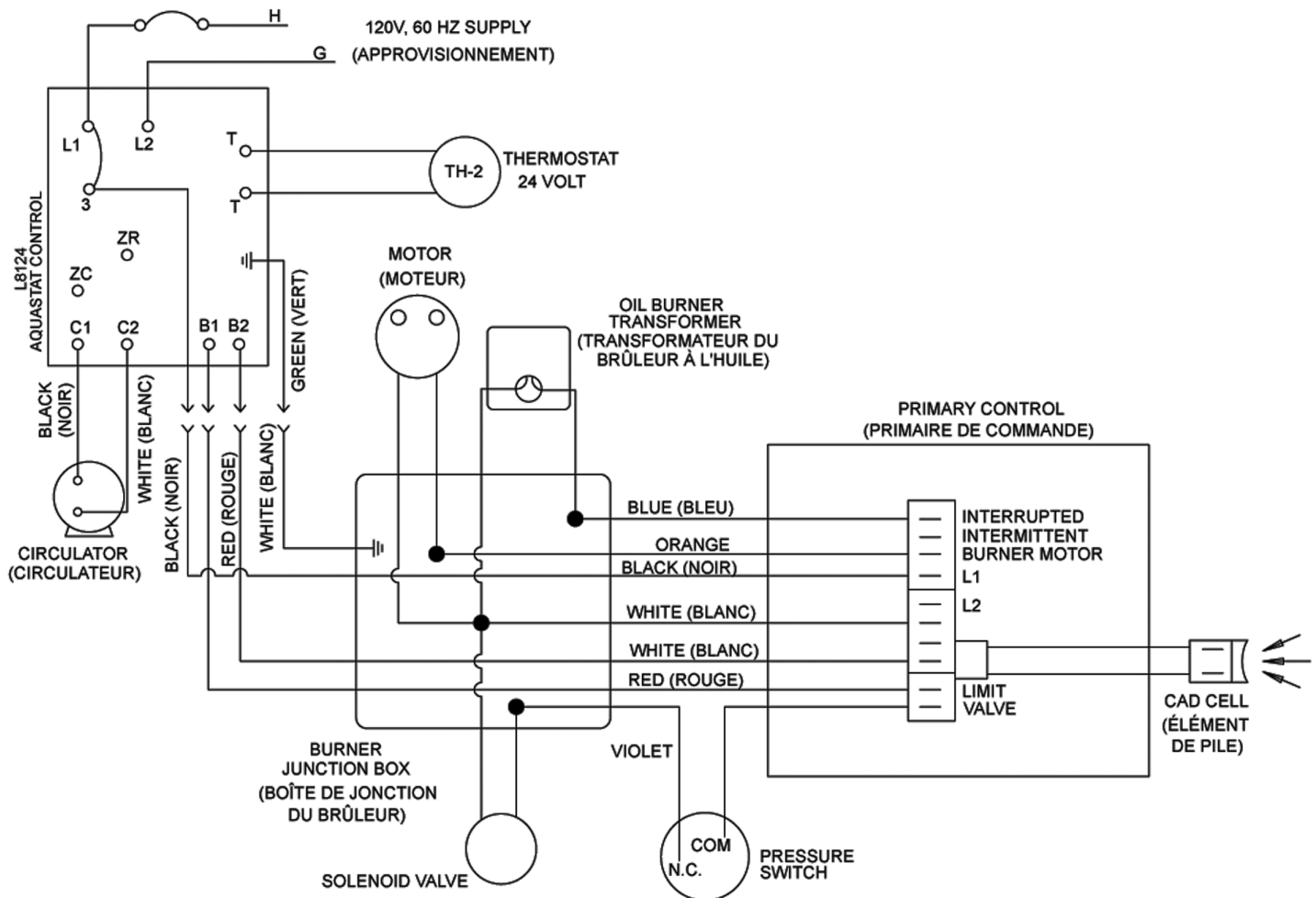

Figure 13 - Wiring Diagram For Oil Fired Boilers With A Circulator Zoned System And A Tankless Heater



THERMOSTAT INSTALLATION

1. Install thermostat on inside wall about four feet above floor.
2. Never install thermostat on outside wall.
3. Do not install thermostat where it will be affected by:
 - A. Drafts
 - B. Hot or cold pipes
 - C. Sun light
 - D. Lighting fixtures
 - E. Television sets
 - F. A fireplace or chimney
4. Check thermostat operation by raising and lowering thermostat as required to start and stop burner.
5. Instructions for final adjustment of thermostat are packaged with thermostat (adjusting heating anticipator, calibration, ect.).

NORMAL SEQUENCE OF OPERATION

- Thermostat will activate, completing circuit to aquastat.
- Circulator motor starts and power is switched to limit. If limit circuit is closed burner motor circuit is energized.
- Burner motor starts prepurge and approximately 15 seconds after solenoid valve opens and ignition system is activated, ignition will begin.
- In event boiler water temperature exceeds high limit setting on boiler mounted aquastat; Power will be interrupted between aquastat and ignition system. Burner motor will continue to run in post purge mode for approximately 2 min. or until water temperature drops below high limit setting. Circulator will continue to operate under this condition until thermostat is satisfied.
- When thermostat is satisfied power is interrupted to boiler mounted aquastat and burner will run in post purge mode for 2 minutes.

OPERATING INSTRUCTIONS

Venting system should be inspected at start of each heating season.

- Check vent pipe from boiler to termination cap for signs of deterioration by rust or cracked silicone joints. Repair if necessary.
- Lever of pressure relief valve, shown in Figure 14, on page 15, on boiler should be operated periodically to make sure it is functioning properly. Pressure relief valve should open before water pressure exceeds 30 lb. reading on gauge. If pressure is exceeded and pressure relief valve leaks water when boiler is operating at normal pressures, immediately replace. Corrosion can build up rapidly at valve seat preventing it functioning as safety device.

- H. Turn "OFF" burner and install pressure gauge in port on pump.
- I. Start burner again and check oil pressure for 140 lbs. Adjust if necessary.



CAUTION

Do not set fire visually.

Instruments are only reliable method to determine proper air adjustments. Improperly adjusted burner causes soot and high fuel bills because of incomplete combustion of fuel oil. This in turn may require excessive boiler maintenance, service costs. Consult competent service mechanic to make proper adjustments with smoke tester, CO₂ indicator and draft gauge. Bacharach or Dwyer test kits include these instruments.



WARNING

Water will be boiling hot.

Start-up and adjustment of oil burner (See oil burner instructions for nozzle and electrode setting).

- A. Check oil burner nozzle to make certain it is tight in adapter. Burner mounting bolts should be tight.
- B. Check electrode setting, as they may have been jarred out of position during transportation.
- C. Lubricate burner motor and circulator motor if required. Some circulators are water lubricated and do not require oiling.
- D. Set room thermostat to call for heat.
- E. Open all oil line valves.
- F. Turn service switch on. Burner should start.
- G. On one pipe fuel systems only, vent pump as soon as burner starts. Allow oil to run until all traces of air in the suction line disappear.

- 1/4" diameter slot is provided in inspection cover plate to take draft reading in combustion chamber.
- 3/8" hole is provided in vent appliance adapter to take draft, CO₂, smoke, and temperature readings.
- Adjust air dial on oil burner to obtain trace of smoke. Measure CO₂ at this point and increase air setting until CO₂ = 1-1.5% lower than reading at trace point.
- Check draft over fire and in vent, normal readings will be positive (+.01 Over-fire & +.02 In Vent) W.C.

INSTRUCTIONS TO OBTAIN PROPER OPERATION OF THE BOILER-BURNER UNIT

Table below is provided as guideline for initial start-up. Final adjustments **MUST** be made using combustion instruments as previously mentioned.

REILLO SETTINGS						
Boiler No.	Burner No.	Air Damp	Turb. Setting	Pump Pressure	Head	Nozzle Furnished
SW3	BF3	4.00	2	150 PSI	6 SLOT	.60 80 W
SW4	BF5	4.25	3	150 PSI	9 SLOT	.85 80 W
SW5	BF5	5.50	4	150 PSI	9 SLOT	1.10 60 B

BECKETT SETTINGS						
Boiler No.	Burner No.	Air Damp	Pin	Pump Pressure	Head	Nozzle Furnished
SW3	AFII 100	3.25	3	140 PSI	HLX 6	.60 45B
SW4	AFII 100	7.50	5	140 PSI	HLX 6	.85 45B
SW5	AF 11 150	5.00	8	140 PSI	HLX 6	1.10 45B

WARNING



- Use only number 2 fuel oil.
- Do not use gasoline, crankcase drainings or any oil containing gasoline.
- Do not attempt to start the burner when excess oil has accumulated, when the unit is full of vapor or when the combustion chamber is very hot.

Check Safety Control Circuit after burner adjustments have been made for satisfactory performance.

A. **HIGH LIMIT CONTROL:** remove cover and note temperature setting. See figure 15 on page 15. With burner operating, decrease this setting to minimum point. When boiler water temperature exceeds this set point, high limit switch will open, shutting off power to oil burner and starting post purge cycle for approximately 2 minutes. Return setting to desired high limit point. Burner should restart.

B. PRIMARY CONTROL AND FLAME SENSOR:

To Check:

- Flame failure - simulate by shutting off oil supply with hand valve while burner is on. 15 seconds after flameout, safety switch locks out, ignition stops, motor stops and oil valve closes. To restart, open oil supply valve and reset safety switch.
- Ignition failure - with burner off, unplug electrical disconnect on burner harness. Disconnect one wire from transformer and put wire nut on disconnected wires. Restore power and run through start-up procedure, safety switch should lockout as flame failure. Reconnect wires after this procedure is complete.
- Power failure - Turn off main power supply switch while burner is operating. When burner stops, restore power and burner should start.

If operation is not as described as above, check wiring and controls.

PREVENTIVE MAINTENANCE

Preventive Maintenance of oil fired boiler reduces operating costs. Boiler and vent pipe should be inspected for accumulation of soot or scale deposits periodically but at least once every year before start of each heating season. When soot is present on section walls and flueways, improper combustion will result, causing additional sooting and scaling until flueways are completely closed. To remove soot and scale from flueways, remove top jacket panel, top clean-out plate, and open burner swing door. (**Figure 14**).

Periodic Inspection and tightening of tankless heater/cover plate bolts will reduce risk of leaks. See **Figure 17**.

INSTRUCTIONS FOR OPENING AND CLOSING BURNER SWING DOOR

Instructions for Opening Burner Swing Door

1. Turn off power to boiler.
2. Allow boiler to cool down.
3. Disconnect power cable at factory supplied burner electrical disconnect. See **Figure 15**.
4. Loosen screws on sides of lower front jacket panel. See **Figure 15**.
5. Pull bottom part of lower front panel forward.
6. Lift lower front panel up and off boiler. See **Figure 15**.
7. Close oil valve. See **Figures 10, and 11**.
8. Disconnect oil line from burner.

NOTICE

Do not try to swing door with oil line attached

9. Disconnect inlet air pipe from side of burner.
10. Remove nut from swing door stud on right hand side of door.
11. Swing open burner and door to left.
12. Using flue brush, brush soot and scale into combustion space where it can be removed through swing door opening.

NOTICE

Use caution when vacuuming in the chamber area. Damage to chamber could result.

Recommend to replace nozzle at start of each heating season. Lubricate burner motor and circulator motor - if required - with few drops of good grade light motor oil. Do not over oil. Have competent service person service burner, check controls and check electrodes for carbon or cracks in insulators. Burners should be adjusted to produce conditions shown in Start-up and Adjustment of Oil Burner procedure.

Instructions for Closing Burner Swing Door

1. Swing burner and door to right until insulation is slightly compressed and stud is exposed.
2. Attach nut to stud and tighten it until built in stop contacts mounting door.
3. Replace oil line to burner.

4. Replace inlet air pipe.
5. Replace lower jacket panel, and tighten screws.
6. Connect power cable at factory supplied burner electrical disconnect.
7. Turn on power to boiler.
8. Bleed oil line.

Figure 14

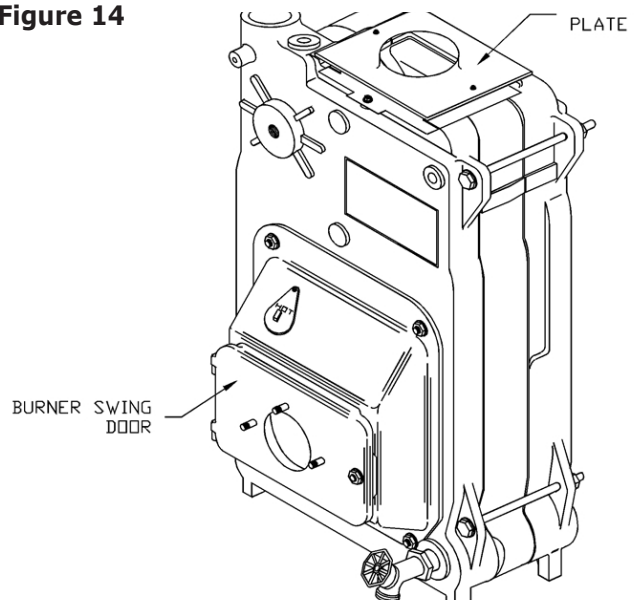
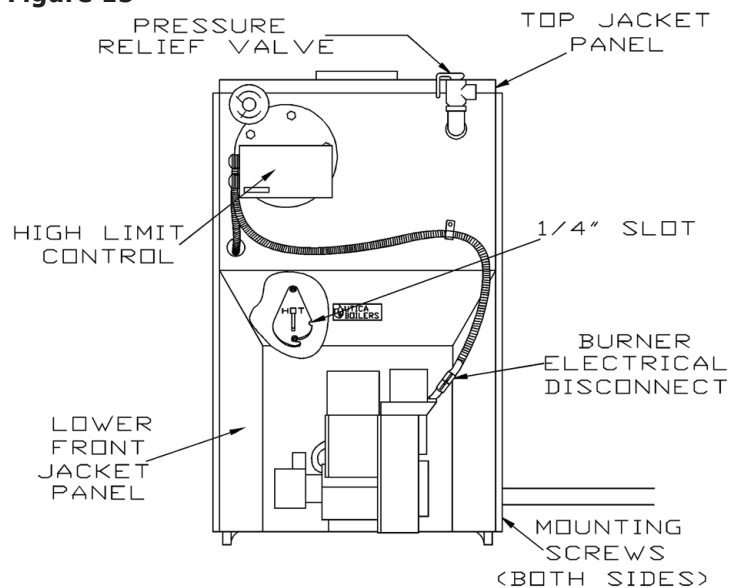

Figure 15



SERVICE CHECK LIST

- | | |
|---|--|
| <input type="checkbox"/> Pump Pressure/Vacuum
<input type="checkbox"/> Line Voltage/Motor Amps
<input type="checkbox"/> Smoke Test
<input type="checkbox"/> Draft Over-fire/In Flue
<input type="checkbox"/> CO ₂ or O ₂
<input type="checkbox"/> Flue Gas Temperature
<input type="checkbox"/> Proper Light-Off (Hot & Cold)
<input type="checkbox"/> Controls and Safety Devices | <input type="checkbox"/> Inspect Chimney and Flue pipe
<input type="checkbox"/> Inspect and Clean Appliance
<input type="checkbox"/> Inspect Oil Line - Size/Leaks
<input type="checkbox"/> Inspect Electrical Connections
<input type="checkbox"/> Install New Filter
<input type="checkbox"/> Room Make-up Air
<input type="checkbox"/> Electrode setting
<input type="checkbox"/> Nozzle-Size, Angle, Type |
|---|--|

Measure with Instruments and Record results on chart provided below.

Date	Nozzle			Pump Pressure PSI	Smoke NO.	Draft		CO ₂ or O ₂	Flue Temperature °F
	Size	Angle	Type			O.F.	INF		

Figure 16 - Heat Exchanger

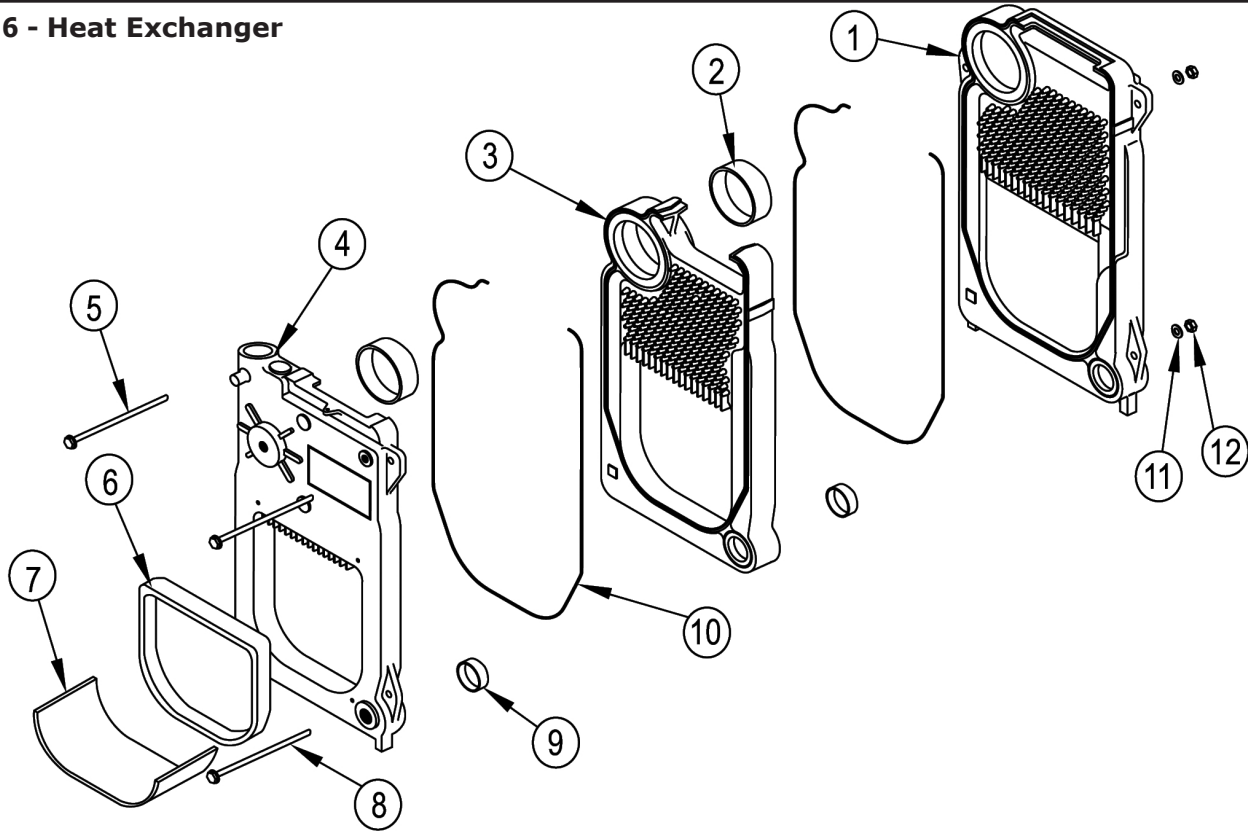

ITEM #	PART #	DESCRIPTION	QTY
1	10051701	REAR SECTION	1
2	100-1-8.01	#60 PUSH NIPPLE	3 Section 2
			4 Section 3
			5 Section 4
3	10051101	CENTER SECTION	3 Section 1
			4 Section 2
			5 Section 3
4	10051201	FRONT SECT. CASTOVER	1
	10051301	FRONT SECT. TANKLESS COIL	1
5	HW02510	TIE ROD 1/2X10.5/8 (3 SEC)	2
	HW02511	TIE ROD 1/2X14.1/4 (4 SEC)	2
6	5611508	KIT - TARGET WALL & INSULATION BLANKET	1
7	N/A	N/A	N/A
8	HW-025.01	TIE ROD 1/2X12.1/2 (3 SEC)	1
	HW-025.01	TIE ROD 1/2X12.1/2 (4 SEC)	1
9	100-1-5.01	#22 PUSH NIPPLE	3 Section 2
			4 Section 3
			5 Section 4
10	MS-006.00	ROPE MED DENSITY	3 Section 13'
			4 Section 19.5'
			5 Section 26'
11	HW-008.03	WASHER 1/2 ID FLAT	3
12	HW-003.05	NUT 1/2-13 HEX HEAD	3

FULLY ASSEMBLED HEAT EXCHANGERS	
PART #	DESCRIPTION
10023701	3 SECT. WITH TANKLESS COIL
10023702	4 SECT. WITH TANKLESS COIL
10023703	5 SECT. WITH TANKLESS COIL
10023601	3 SEC. WITH CAST OVER
10023602	4 SEC. WITH CAST OVER
10023603	5 SEC. WITH CAST OVER

Figure 17 - COIL

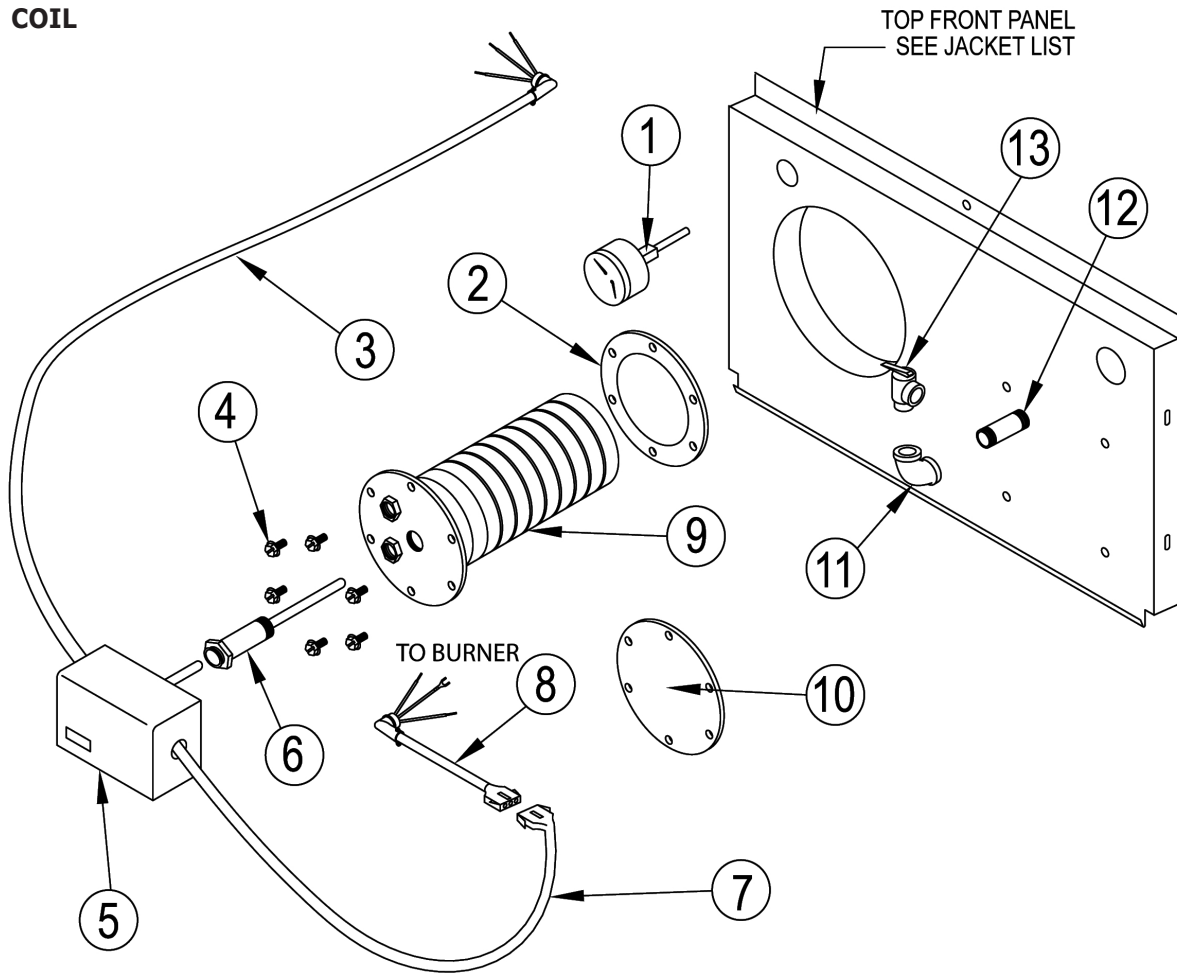

ITEM #	PART #	DESCRIPTION	QTY
1	GA-001.00	GAUGE THERALTIMETER, WATER	1
2	2551401	GASKET - SILICON/DURO 70	1
3	37519501	HARNES CIRCULATOR	1
4	HW08001	BOLT 5/16" X 3/4"	6
5	1010001	CONTROL L8148A (FOR BOILERS WITHOUT A TANKLESS COIL)	1
	AQ-010.00	CONTROL L8124A (FOR BOILERS WITH A TANKLESS COIL)	1
6	AQ-020.01	WELL	1
7	28512201	HARNES, AQUASTAT	1
8	28512301	HARNES, BURNER (BECKETT)	1
	1263011	HARNES, BURNER (RIELLO)	1
9	5612001	TANKLESS COIL KIT P3 (FOR 3 SECTION BOILERS)	1
	5612002	TANKLESS COIL KIT T4 (FOR 4 & 5 SECTION BOILERS)	1
10	27511401	TANKLESS - COVER KIT	1
11	PF-002.04	PIPE FIT ELBOW 3/4" NPT	1
12	PF-005.11	PIPE FIT - NPL 3/4" X 4" NPT	1
13	VR-001.01	RELIEF VALVE 30#	1

Figure 18 - Swing Door And Mounting Door Components

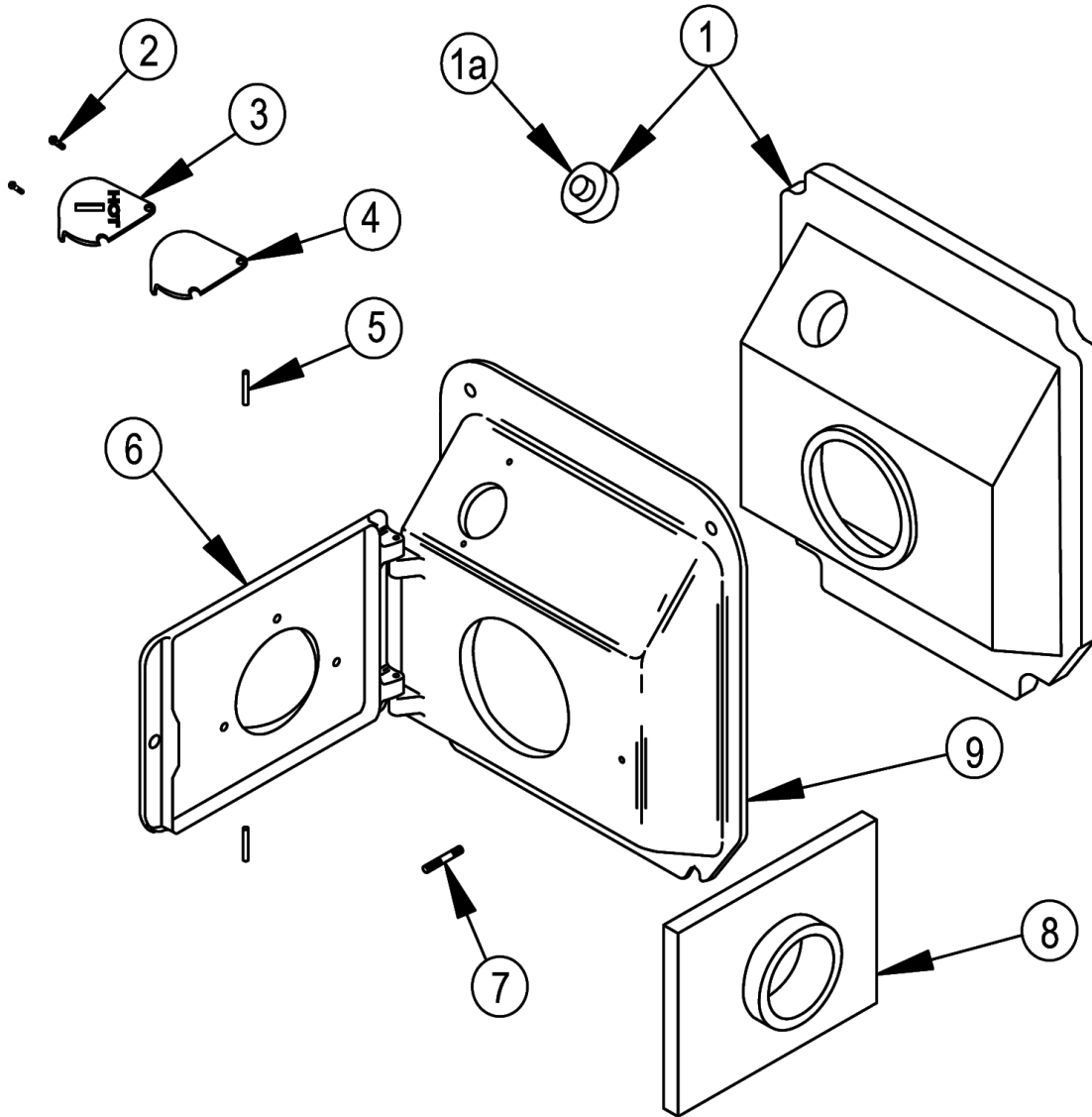

ITEM #	PART #	DESCRIPTION	QTY
1	2552901	MOUNTING DOOR INSULATION & PLUG	1
2	HW-005.01	SCREW 1/4-20X1/2 SELF TAPPING	2
3	10011701	OBSERVATION DOOR	1
4	25511101	OBSERVATION DOOR GASKET	1
5	HW06801	1/4X1.3/4 DRIVE LOCK PIN	2
6	10011501	SWING DOOR	1
7	HW06701	5/16X18X2.3/8 STUD	1
8	2553301	INSULATION-SWING DOOR (FOR BOILERS WITH RIELLO BURNERS ONLY)	1
	2553303	INSULATION-SWING DOOR (FOR BOILERS WITH BECKET BURNERS ONLY)	1
9	10011301	MOUNTING DOOR	1

Figure 19 - Jackets

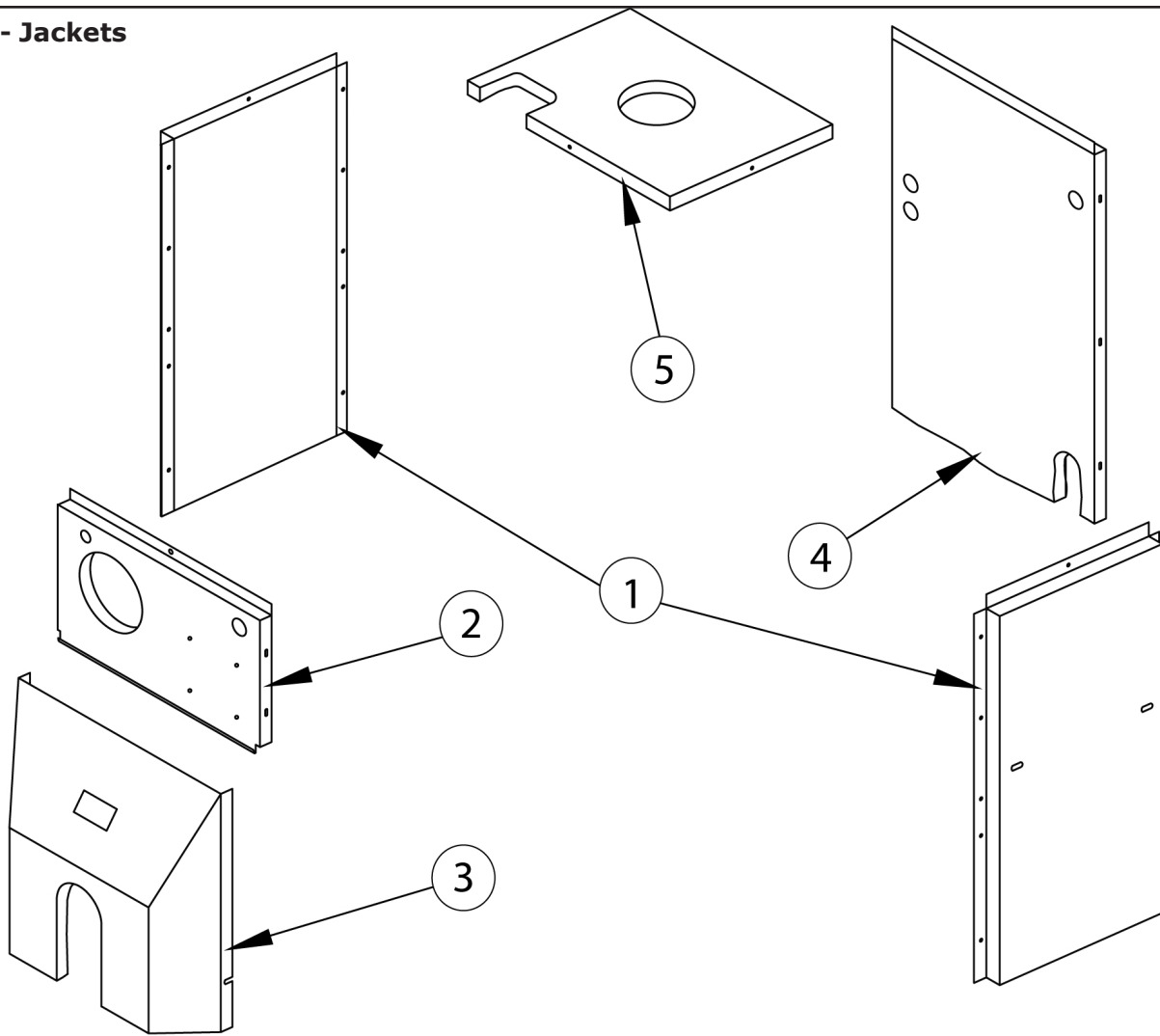

ITEM #	PART #	DESCRIPTION	QTY
1	21521802	SIDE PANEL 3 SECTION	2
	21521803	SIDE PANEL 4 SECTION	2
	21521804	SIDE PANEL 5 SECTION	2
2	21522401	TOP FRONT PANEL C/O	1
	21522402	TOP FRONT PANEL TANKLESSS COIL (SHOWN)	1
3	21521901	LOWER COWL	1
4	21521501	REAR PANEL	1
5	215-1-3.02	TOP PANEL 3 SECTION	1
	215-1-3.03	TOP PANEL 4 SECTION	1
	215-1-3.04	TOP PANEL 5 SECTION	1

Figure 20 - Hardware

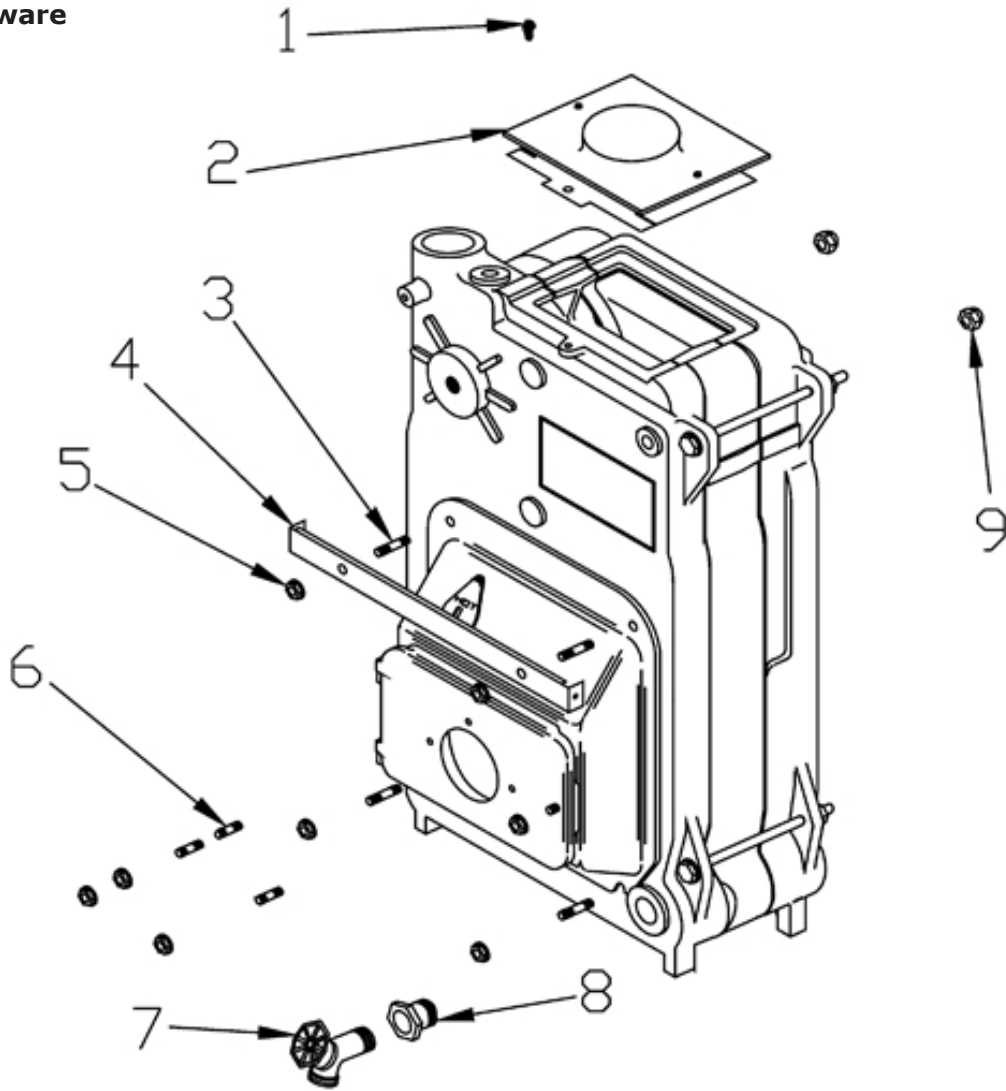

ITEM #	PART #	DESCRIPTION	QTY
1	HW-005.01	SCREW 1/4-20X1/2 SELF TAP	1
2	24521301	FLUE COLLECTOR ASSY (3 SECT)	1
	24521302	FLUE COLLECTOR ASSY (4 SECT)	1
	24521303	FLUE COLLECTOR ASSY (5 SECT)	1
3	HW06701	STUD 5/16"-18 X 2.3/8"	4
4	2252501	SUPPORT JACKET BRACKET	1
5	HW06901	NUT 5/16-18 WISLOCK	8
6	HW07001	STUD 5/16"-18 X 1.3/8"	3
7	HW-016.02	DRAIN LONG	1
8	PF-004.04	PIPE FIT BUSHING 1.1/4" X 3/4"	1
9	HW06401	NUT - ACORN 1/2"-13 UNC YELLOW	2

Figure 21 - Termination Kit Assembly

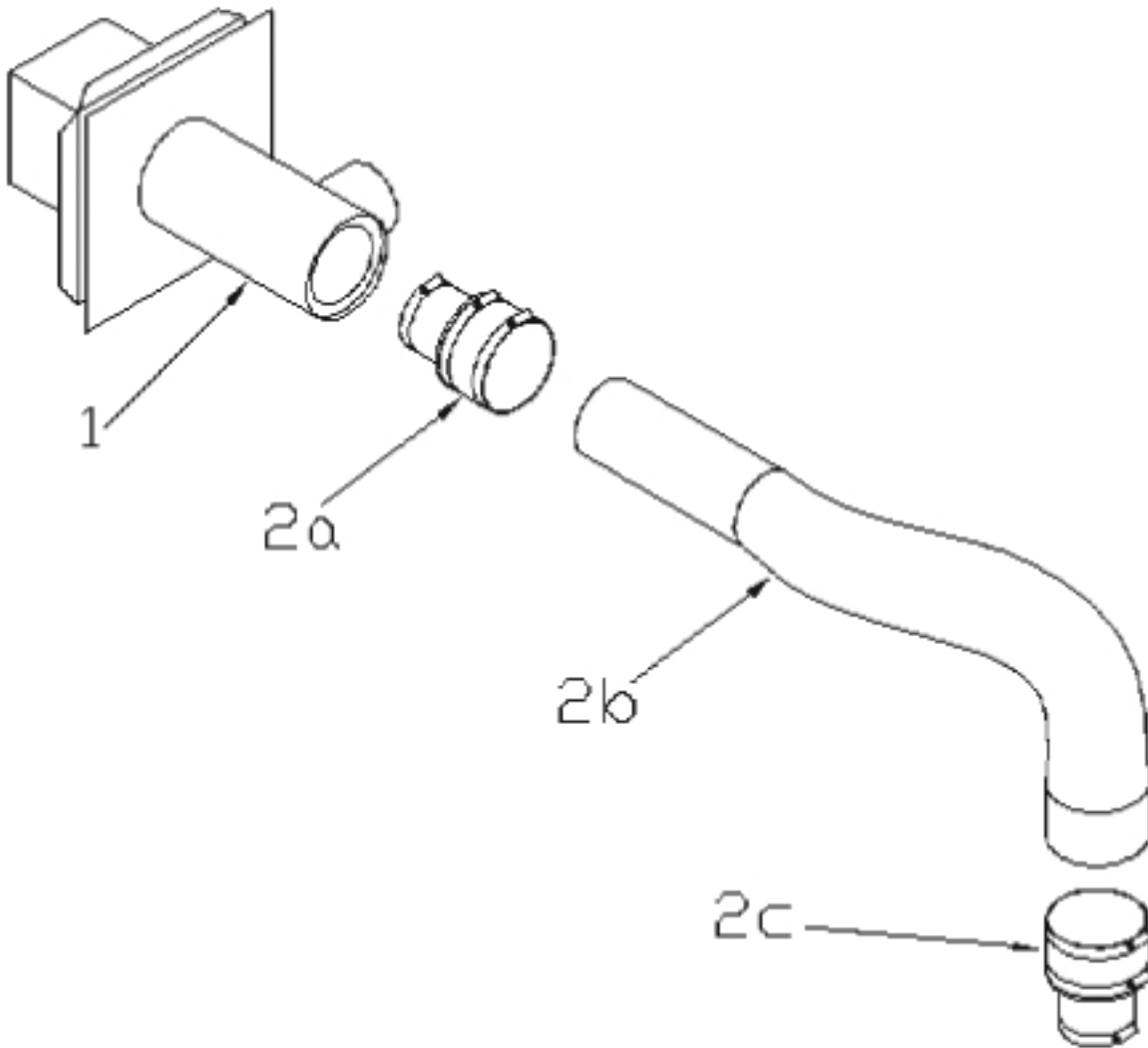

ITEM #	PART #	DESCRIPTION	QTY
1	1580004	TERMINATION 4" FLEX-L CFTSW4-UT	1
2	1580005	TERM. KIT 4" FLEX-L CFK104-UT INCLUDES A,B,C	A) TERMINAL ADAPTER CFAT44
		B) 10' x 4' VENT KIT CFV104/6	1
		C) APPLIANCE ADAPTER CFAA44P	1

SW SERIES REPLACEMENT PARTS

BURNER COMPONENTS			
ITEM #	PART #	DESCRIPTION	QTY
1	BN08701	BURNER OIL UT1601 AFII 100 (SW3)	1
	BN08702	BURNER OIL UT1602 AFII 100 (SW4)	1
	1050012	BURNER OIL UT1603 AFII 150 (SW5)	1
2	BN08001	BURNER OIL FLANGE GASKET #3616	1
	30A055901	GASKET OB MT FLG #3416	1
3	CD-001.01	CAD CELL (FOR BOILERS WITH BECKETT ONLY)	1
4	RY00501	CONTROL R1784P1031 (HONEYWELL)	1
	240008817	CONTROL 7505P152M (BECKETT)	1
5	NZ01001	NOZZLE .60 45B (SW3) (BECKETT)	1
	NZ01101	NOZZLE .85 45B (SW4) (BECKETT)	1
	1320021	NOZZLE 1.10 45B (SW5) (BECKETT)	1
	1320022	NOZZLE .60 80W (SW3) (RIELLO)	1
	1320023	NOZZLE .80 60W (SW4) (RIELLO)	1
	1320024	NOZZLE 1.10 60B (SW5) (RIELLO)	1
6	CALL	BURNER OIL 40BF3 - (SW3) (RIELLO)	1
	CALL	BURNER OIL 40BF5 - (SW4) (RIELLO)	1
	CALL	BURNER OIL 40BF5 - (SW5) (RIELLO)	1
BECKETT AFII BURNER PARTS			
1	RP03801	BLAST TUBE AF2	
2	RP03901	FUEL PUMP AF2 DANFOSS	
3	RP04001	7" DRAWER ASSY AF2	
4	RP04101	OIL BRN TRANSFORMER AF2	
5	RP04201	OIL BRN MOTOR AF2	
6	RP03701	FUEL PUMP	
7	RP04401	SOLENOID VALVE COMB.	
RIELLO BURNER PARTS			
1	30A064701	BRN PUMP DRIVE KEY RIELLO	
2	30A064801	BRN PRIMARY CTRL-53OSE RIELLO	
3	30A064901	BRN COIL RIELLO	
4	30A065101	BRN MOTOR RIELLO	
5	30A065201	BRN CAPACITOR 12.5uF RIELLO	
6	30A065301	BRN ELECTRODE PORCELAIN RIELLO	
7	30A065401	BRN PUMP RIELLO	
8	30A065501	BRN HYDRAULIC JACK RIELLO	
9	30A065601	BRN O-RING PUMP PRESS RIELLO	
10	30A065701	BRN PHOTO CELL RIELLO	
11	10500015	BRN K7R POST PURGE CONTROL	

SW SERIES REPLACEMENT PARTS



RATINGS AND DATA

(1) BOILER MODEL NUMBER	(2)* I=B=R OIL BURNER INPUT		D.O.E. HEATING CAPACITY	(3)* I=B=R NET RATINGS	PUMP PRESSURE	A.F.U.E.
	G.P.H.	MBH	MBH*	WATER MBH	PSI	RATING
SW3	.65	91	79	68.7	140	86
SW4	1.00	140	120	104	140	86
SW5	1.25	175	150	130	140	86

NOTE: For altitudes above 2,000 ft. ratings may be reduced at the rate of 4% for every 1,000 ft. above sea level.

STANDARD EQUIPMENT: Crated Boiler, Flush Jacket, Oil Burner, Target Wall/Liner, Circulator-1.1/4", ASME Relief Valve, Theraltimeter Gauge, Drain Cock, Wiring Harness, Burner Electrical Disconnect, Plastic Cover, Supply Tapping-2", Return Tapping-1.1/4", High Limit and Circulator Control, Primary Control. For Tankless Heater Units-add Tankless Hot Water Coil, Flow Restrictor and Triple Aquastat Relay.

TANKLESS WATER HEATER CAPACITIES

BOILER MODEL NUMBER	FIRING RATE G.P.H.	TANKLESS HEATER NUMBER	TANKLESS HEATER CAPACITY INTERMITTENT DRAW G.P.M.	BOILER WATER CONTENT GALS.
SW3	.65	P3	AVAILABLE ON REQUEST	10.5
SW4	1.00	T4	3.25	13.5
SW5	1.25	T4	3.75	16.5

DIMENSIONS

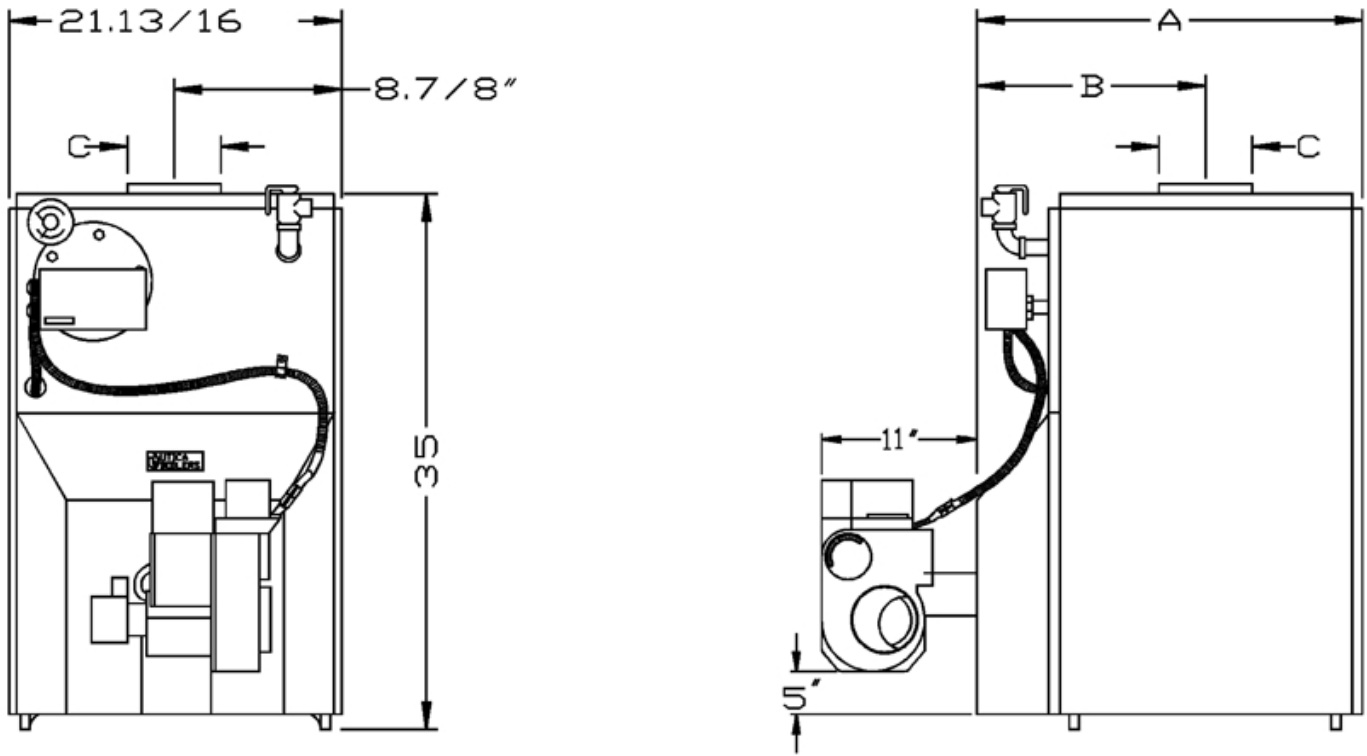

BOILER NO.	A LENGTH OF FLUSH JACKET	B FRONT OF CASTING TO CENTER LINE OF FLUE OUTLET	C DIAMETER OF FLUE OUTLET
SW3	17.7/8"	11.1/4"	4"
SW4	21.1/2"	12.5/8"	4"
SW5	25.1/8"	14.1/4"	4"

NOTES:

1. Add suffix "T" to denote boiler with tankless heater.
2. I=B=R burner capacity is based on an oil heating value of 140,000 Btu/gal. and with 13% CO².
3. Net ratings based on 170 °F temperature in radiators and include 15% allowance for normal piping and pickup load. Consult manufacturers for unusual piping and pick-up requirements.
* All ratings subject to verification.
4. 120 Volts, 15 Amps, & 60 Hz. required to operate this boiler.
5. The MEA number for the SFH-W series is 182-86E
6. The MEA number for the Beckett burners used on the SFH-W are as follows:

AFII 100	456-90-E
AFII 150	456-90-E



SW

OIL FIRED DIRECT EXHAUST
CAST IRON BOILER

