



**BCL-S BFL
(Lowboy Model)
BCL
(High Capacity Lowboy Model)**

Oil Fired Warm Air Furnaces

**INSTALLATION, OPERATION &
MAINTENANCE MANUAL**



Dimensions

BCL - REAR BREECH

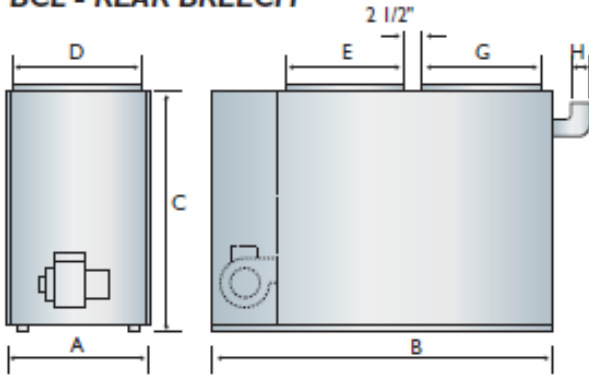

BFL - FRONT BREECH

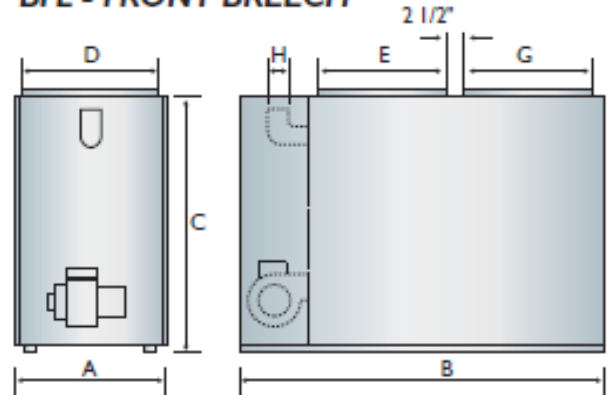

BCL 190/225 REAR BREECH

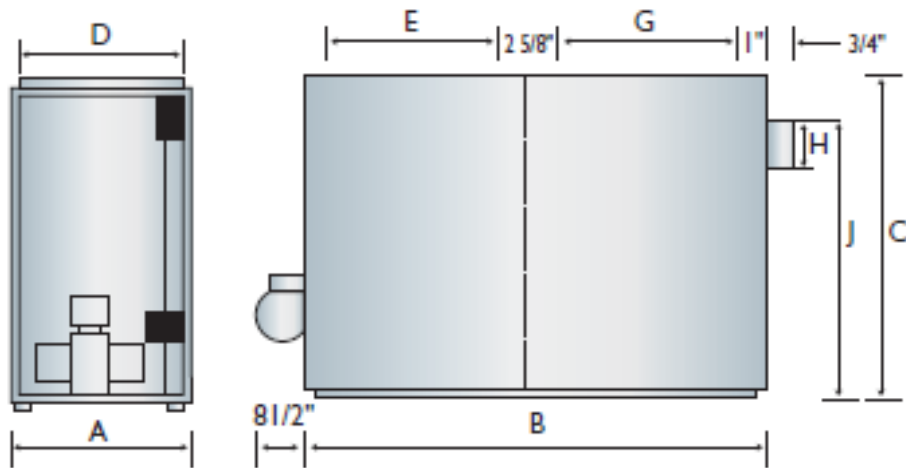

Furnace Model	Cabinet			Plenum Openings		Flue		Filter (Permanent)	Shipping Weight (LB)
	Width A	Length B	Height C	Supply D x E	Return F x G	Diameter H	Height J		
BCL-S	22	51½	41	20½ x 18%	20½ x 18%	6	37¼	20 x 25 x 1	280
BFL	22	51½	41	20½ x 18%	20½ x 18%	6	38¼	20 x 25 x 1	250
BCL High Capacity	26	49	56	24 x 22	24 X 22	7	47	20 x 25 x 1 (2)	390

Contents

Dimensions.....	2
1. General	4
2. Safety Symbols	4
3. Introduction	4
4. Heat Loss	4
5. Locating the Unit - [See Table 1].....	5
6. Furnace Used In Conjunction With Air Conditioning.....	5
7. Combustion Air.....	6
8. Chimney Venting	6
9. Barometric Damper Control.....	7
10. Optional Side Wall Venting.....	7
11a. Models with Electronic Fan Timer control and Snap-Disc Limit Control (See Figure 3).....	7
11b. Models with Mechanical Fan And Limit Control	8
12. Electrical Connections	8
13. Humidifier	9
14. Piping Installation	9
15. Oil Filter	9
16. Oil Burner Nozzles.....	9
17. Oil Burner Adjustment	9
18. Burner Electrodes.....	9
19. Burner Primary (Safety) Control.....	9
20. Combustion Chamber	9
21. Circulating Air Blower	10
22. Maintenance And Service	11
23. Operating Instructions	12
Appendix A - Check Out and Adjustments	13
A.1 Oil Burner Air Adjustment.....	14
A.2 Burner Electrodes.....	15
A.3 Start Up.....	15
A.4 Special Instructions For Units Equipped With Riello Burners.....	16
A.5 Final Check Out	16
Blower Setup Tables.....	17
Airflow Characteristics Tables	19
Appendix B - Wiring Diagrams.....	21
Chimney Vent Direct Drive Furnace Wiring Diagram BCL-S & BFL With Fan and Limit Control.....	21
Chimney Vent Belt Drive Furnace Wiring Diagram BCL-S & BFL & BCL High Capacity with Fan and Limit Control.....	22
Direct Vent Direct Drive Furnace Wiring Diagram BCL-S & BFL with Fan and Limit Control	23
Chimney Vent Furnace Wiring Diagram BCL-S & BFL with Fan Timer Control.....	24
Direct Vent Furnace Wiring Diagram BCL-S & BFL with Fan Timer Control	25
Appendix C - Sequence of Operation and Troubleshooting	26
C.1 Troubleshooting	27
C.2 Preliminary Steps:.....	27
C.3 Check Oil Primary Control.....	27
Parts Listing	31
Model BCL High Capacity Diagram.....	31
Model BCL-S Diagram (Fan and Limit Control Shown).....	34
Model BFL Diagram (Fan and Limit Control Shown).....	39
Home Owners Reference Table.....	44

Check our website frequently for updates: www.ecrinternational.com

Information and specifications outlined in this manual in effect at the time of printing of this manual. Manufacturer reserves the right to discontinue, change specifications or system design at any time without notice and without incurring any obligation, whatsoever.

1. General

Furnace installation shall be completed by qualified agency. See glossary for additional information.

WARNING

Fire, explosion, asphyxiation and electrical shock hazard. Improper installation could result in death or serious injury. Read this manual and understand all requirements before beginning installation.

WARNING

Fire, burn, asphyxiation hazard. Do not use gasoline, crank case oil, or any oil containing gasoline. Failure to follow these instructions could result in death or serious injury.

2. Safety Symbols

Become familiar with symbols identifying potential hazards.



This is the safety alert symbol. Symbol alerts you to potential personal injury hazards. Obey all safety messages following this symbol to avoid possible injury or death.

DANGER

Indicates a hazardous situation which, if not avoided, WILL result in death or serious injury

WARNING

Indicates a hazardous situation which, if not avoided, could result in death or serious injury.

CAUTION

Indicates a hazardous situation which, if not avoided, could result in minor or moderate injury.

NOTICE

Used to address practices not related to personal injury.

3. Introduction

• Models BCL (90, 100, 120, 130, 145) S

BCL-S models are rear breech oil fired forced air lowboy furnaces with output capacity range of 90,000 to 141,000 Btu/hr.

• Models BFL (90, 100, 120, 130, 145)

BFL models are front breech oil fired forced air lowboy furnaces with output capacity range of 88,000 to 139,000 Btu/hr.

• Models BCL (170-2, 190, 200, 225)

BCL models are rear breech high capacity oil fired forced air lowboy furnaces with output capacity range of 177,000 to 237,000 Btu/hr. Shipped in two pieces; furnace section and blower section, which are assembled together at the installation site.

Furnace models are either factory equipped for chimney venting or factory equipped for direct venting.

Chimney vent models and direct vent models are not field convertible. Direct vent installation instructions are included with the direct vent models.

Installation shall conform to requirements of authority having jurisdiction or in absence of such requirements:

- Canada - CAN/CSA - B139, Installation Code for Oil-Burning Equipment.
- United States - National Electrical Code, NFPA31, Standard for the Installation of Oil-Burning Equipment.

Models are CSA listed, (NRTL/C) for use with No. 1 (Stove) and No. 2 (Furnace) Oil.

Refer to tables in Appendix A for performance data.

4. Heat Loss

Maximum hourly heat loss for each heated space shall be calculated in accordance with the procedures described in the manuals of:

- Canada - The Heating, Refrigeration and Air Conditioning Institute of Canada (HRAI), or by other means prescribed, or approved by the local authority having jurisdiction.
- United States - Manual J. titled, "Load Calculation" published by the Air Conditioning Contractors of America, describes a suitable procedure for calculating maximum hourly heat loss.

5. Locating the Unit - [See Table 1]

- Locate furnace so flue connection to chimney is short, direct and consists of as few elbows as possible.
- Centralize furnace location with respect to supply and return air ductwork. Central location minimizes trunk duct sizing.
- All models may be installed on combustible floors.

6. Furnace Used In Conjunction With Air Conditioning

- Install furnace in parallel with or upstream from evaporator coil to avoid condensation in heat exchanger.
- When installed in parallel, prevent chilled air from entering furnace by use of dampers or air controlling.
- Manually operated dampers must have a control to prevent operation of either system unless dampers are in full heat or full cool position.
- Air heated by the furnace shall not pass through evaporator coil unless coil is specifically approved for such service.
- Check and adjust blower speed to compensate for pressure drop caused by evaporator coil.

Table 1: Minimum Installation Clearances

Location	Clearance to Combustibles (Inches)	
	BCL-S and BFL	BCL High Capacity
Top	1	3
Bottom	0	0
S/A Plenum	1	3
Rear	6*	24
Side 1	6*	6***
Side 2	24	18
Front	24	24
Flue Pipe	9**	9**
Enclosure	Standard	Standard

* 24 Required Service Clearance
** 18 in USA
*** Required on one side only for service to rear

7. Combustion Air

- Furnace installed in a closet or utility room, provide two openings connecting to well-ventilated space (full basement, living room or other room opening, not a bedroom or bathroom).
 - A. One opening shall be located above level of upper vent opening.
 - B. One opening below combustion air inlet opening in front of furnace.
- Each opening shall have a minimum free area of 1½ square inches per 1,000 Btu/h of total input rating of all appliances installed in the room.
- For furnaces located in buildings of unusually tight construction, such as those with high quality weather stripping, caulking, windows and doors, or storm sashed windows, or where basement windows are well sealed, a permanent opening communicating with a well ventilated attic or with the outdoors shall be provided, using a duct if necessary. The duct opening shall have a free area of 1½ square inches per 1,000 Btu/h of total input rating of all appliances to be installed.
 - Furnace installed in a full basement, infiltration is normally adequate to provide air for combustion and draft operation.
 - Furnace rooms under 65m³ (700 ft³) should automatically be treated as confined space.

8. Chimney Venting

- Flue pipe should be as short as possible with horizontal pipes sloping upward toward the chimney at a rate of one-quarter inch per foot.
- Flue pipe should not be smaller in cross sectional area than flue collar on the furnace.
- Flue pipe should connect to chimney so the flue pipe extends into, and terminates flush with the inside surface of chimney liner. Seal the joint between pipe and lining.
- Chimney outlet should be at least two feet above highest point of peaked roof.
- All unused chimney openings should be closed.
- Chimneys must conform to local, provincial or state codes, or in the absence of local regulations, to the requirements of the National Building Code.

NOTICE

This furnace is approved for use with Type L vent or equivalent. Maximum vent temperature for Type L vent is 575°F (300°C).

⚠ WARNING

Asphyxiation hazard. Chimney vented versions of furnace must be connected to flue having sufficient draft at all times. Failure to follow these instructions could result in death or serious injury.

Manufacturer recommends over fire draft of -0.02 in. w.c. See Figure 2.

Flue pipe must not pass through any floor or ceiling, may pass through a wall where suitable fire protection provisions have been installed.

- Refer to CAN/CSA B-139 for rules governing the installation of oil burning equipment.
- United States, refer to NFPA 31 for regulations governing the installation of oil burning equipment.

See Appendix A for burner set-up.

Figure 2 - Check Over-Fire Draft



Over-fire draft access port.

9. Barometric Damper Control

Barometric damper control, also known as draft regulator, is used on conventional chimney venting only. Control automatically maintains constant negative pressure. Ensures proper pressures are not exceeded. If chimney does not develop sufficient draft, draft control does not function properly.

- Install draft regulator in same room or enclosure as furnace. Draft regulator should not interfere with combustion air supplied to the burner.
- Locate control near furnace flue outlet.
- Install per instructions supplied with regulator.
- Set over fire draft, measured at oil burner mounting plate over-fire draft access port, to -0.02 in. w.c. See Figure 2 page 6.

10. Optional Side Wall Venting

Certain BCL-S and BFL furnace models are manufactured as sidewall vented units. Refer to Direct Venting Instructions, P/N 240006979 included with Vent Kit for details.

Sidewall Venting (*Direct Venting*) requires use of specific oil burners; Beckett AFII.

Refer to Appendix A, Table A2.

11a. Models with Electronic Fan Timer Control and Snap-Disc Limit Control (See Figure 3)

Electronic Fan Timer integrates control of burner and circulator fan operations. Control is central wiring point for most of furnace electrical components.

- United Technologies 1158-120 has an adjustable fan on time set by selecting dipswitch combination displayed in Chart 1. Fan on delay can be set at 30, 60, 90 or 120 seconds. Provides a delay between burner ignition and blower start-up to eliminate excessive flow of cold air when blower comes on.
- United Technologies 1158-120 has an adjustable fan off time of 2, 3, 4 or 6 minutes as displayed in Chart 1. Fan off delay time starts when burner motor is de-energized at end of call for heat. Blower shutdown is delayed to remove any residual heat from heat exchanger.
- Electronic fan timer board works in conjunction with snap disc limit controls, performing a safety function, and breaks power to oil burner primary control, shutting off burner if furnace over-heats.
- Limit control is thermally operated and automatically resets. Limit control is factory installed, pre-set and is not adjustable.
- If limit control opens with United Technologies 1158-120 electronic fan control, circulating fan will energize. When limit closes, fan off timer begins. At the end of fan off time cycle burner is energized, initiating normal burner cycle.

FIGURE 3: UNITED TECHNOLOGIES 1158-120 FAN TIMER BOARD

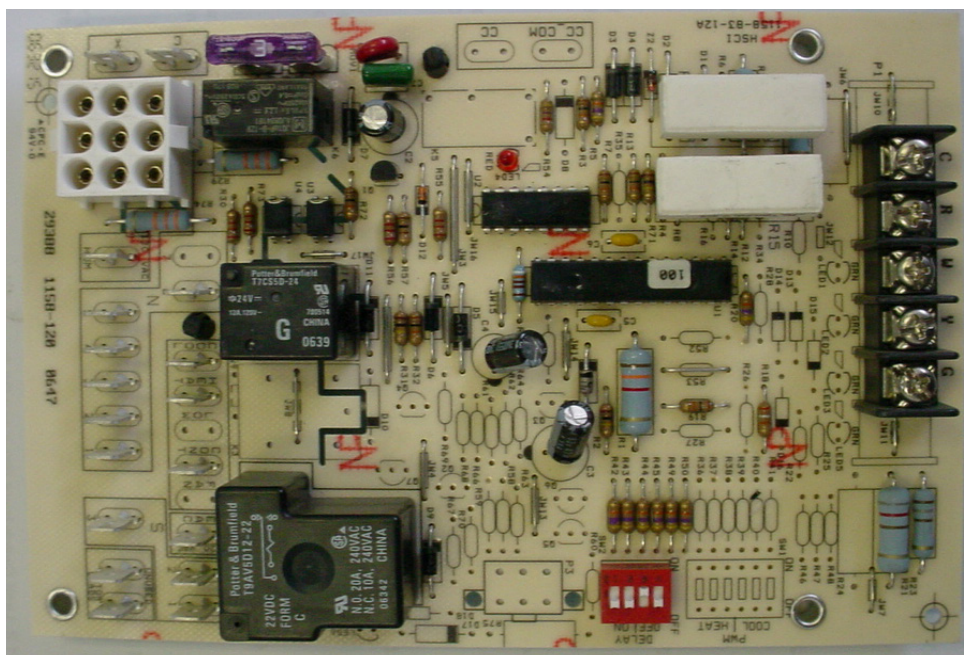

Chart 1- United Technologies 1158-120

Dip Switch Position				Blower Delay Times	
1	2	3	4	On Seconds	Off Minutes
Off	Off			30	
On	Off			60	
Off	On			90	
On	On			120	
		Off	Off		2
		On	Off		3
		Off	On		4
		On	On		6

11b. Models with Mechanical Fan And Limit Control

Furnace may be equipped with either Honeywell L4064B or White Rodgers 5D51 fan and limit control. Temperature sensitive fan switch is actuated by a helical bi-metal sensing element enclosed in a metal guard, and controls the circulating air blower. This provides a delay between burner ignition and blower start up to eliminate excessive flow of cold air when blower comes on.

Blower shutdown is also delayed to remove any residual heat from heat exchanger and improve annual efficiency of the furnace. Fan on settings of 110° F to 130° F (43° C to 55° C) and fan off settings of 90° F to 100° F (32° C to 37° C) will usually be satisfactory.

Limit switch performs safety function and breaks power to oil burner primary control, which shuts off the burner if furnace over-heats. Limit control is thermally operated and automatically resets.

Limit control is factory installed, pre-set. Limit control incorporates a limit stop which prevents the limit switch from being set above the factory setting. Do not tamper with or attempt to adjust limit stop. The limit control should be set at or below the factory setting. **DO NOT SET LIMIT CONTROL ABOVE FACTORY SETTINGS.**

Model	Factory Limit Control Setting
BCL-S	230°F
BFL	190°F
BCL High Capacity	200°F

Limit control and fan control are incorporated in same housing and are operated by the same thermal element.

12. Electrical Connections

- Furnace is listed by Canadian Standards Association under NRTL (North American) Standard.
- All field wiring shall conform to CAN/CSA C22.1 Canadian Electrical Code, Part 1, and by local codes, where they prevail.
- United States, wiring shall conform to National Fire Protection Association NFPA-70, National Electrical Code, and with local codes and regulations.
- Wire furnace to separate dedicated circuit in main electrical panel.
- Suitably located circuit breaker can be used as service switch, separate service switch is advisable.
- Service switch is necessary if circuit breaker is close to the furnace, or furnace is located between circuit breaker and entry to furnace room.
- Clearly mark service switch. Install in accessible area between furnace and furnace room entry. Locate so as to reduce possibility it can be mistaken as light switch or similar device.
- Power requirement is: 120 VAC, 1 Ø, 60 Hz.

Factory Equipped Blower	Amps
1/3 and 1/2 HP	12
3/4 HP Belt Drive and 1 HP Direct Drive	15
1 HP Belt Drive	20

- Accessories requiring 120 VAC power sources such as electronic air cleaners and humidifier transformers may be powered from furnace circuit, or from electronic fan timer board where provisions have been made for such connections, but should have their own controls.
- Do not use direct drive motor connections as a power source, there is risk of damaging accessories.
- Thermostat wiring connections are shown in wiring diagrams in Appendix B. Some micro-electronic thermostats require additional controls and wiring. Refer to thermostat manufacturer's instructions.
- Locate thermostat approximately 5 feet above floor, on inside wall, and where thermostat is exposed to average room temperatures. Avoid locations where thermostat is exposed to cold drafts, heat from nearby lamps and appliances, exposure to sunlight, heat from inside wall stacks, etc.
- Adjust thermostat heat anticipator to amperage draw of heating control circuit as measured at "R" and "W" terminals of thermostat. Do not measure current with thermostat connected to the circuit. Measure amperage by connecting ammeter between two wires which connect to thermostat "R" and "W" terminals.

13. Humidifier

- Humidifier is optional accessory available through most heating supplies outlets.
- Follow humidifier manufacturer's installation instructions
- Protect furnace heat exchanger from water or water droplets from humidifier.
- Do not use direct drive motor connections as source of power for 120 VAC humidifiers and humidifier transformers.

14. Piping Installation

- Install fuel system in accordance with requirements of CAN/CSA B-139, and local regulations.
- United States installation shall conform to NFPA No. 31 and local codes and authorities.
- Use only approved fuel oil tanks, piping, fittings and oil filter.
- Install oil filter as close to burner as possible.
- Refer to instructions and illustrations in oil burner and oil pump instructions shipped with the furnace.

15. Oil Filter

Install oil filter between fuel oil storage tank and oil burner. When using oil burner nozzle smaller than 0.65 U.S. Gallons Per Hour, install additional 7 to 10 micron filter as close as possible to oil burner.

16. Oil Burner Nozzles

Furnaces are certified for multiple firing rates. Furnace may be fired at ideal rate for wide range of structures by manipulating oil burner, nozzle, flame retention head, and temperature rise. Refer to Table A-1 thru A-3, and furnace rating plate to determine proper combinations.

17. Oil Burner Adjustment

- Adjust burner air supply to maintain fuel to air ratio to obtain ideal combustion conditions.
- Lack of air causes "soft" and "sooty" flames, resulting in soot build-up throughout heat exchanger passages.
- Excess combustion air causes bright roaring fire and high stack temperatures resulting in poor fuel efficiency.
- Furnaces operate most efficiently with No. 1 smoke spot on Bacharach Scale. Dust will eventually build up on air moving components of oil burner assembly resulting in decreased air supply with potential soot build up in flue gas passageways of heat exchanger. Soot behaves as insulator and impairs good heat transfer. Stack temperature increases, and efficiency decreases. To avoid this problem, adjust the air supply to provide no more than trace smoke spot on Bacharach Scale.
- See Venting Instructions included in Vent Kits for set-up details for sidewall vented furnaces.

NOTICE

Set up sidewall vented models to deliver zero (0) smoke.

NOTICE

Before operating furnace check burner alignment with combustion chamber. End cone of air tube must be centred to accommodating ring of combustion chamber. Adjust as necessary.

18. Burner Electrodes

Correct positioning of electrode tips with respect to each other, fuel oil nozzle, and burners is essential for smooth light ups and proper operation.

Refer to oil burner instructions provided with furnace and Appendix A Section A.2 for electrode specifications.

NOTICE

Do not tamper with furnace controls they are sensitive. If problems persist, call your service contractor.

19. Burner Primary (Safety) Control

Furnace is equipped with primary combustion control, also referred to as burner relay or burner protector relay, which uses a cad cell located in burner housing, to monitor and control combustion.

Dust or combustion residuals can build up on lens of cad cell impairing its response to flame. Check cad cell for cleanliness and proper alignment if primary control frequently shuts down combustion.

20. Combustion Chamber

Furnace is equipped with cerafelt combustion chamber, held in place by a retaining bracket.

Check the alignment of the combustion chamber and oil burner before firing. It is possible for the combustion chamber to shift if subjected to rough handling during transit.

Inspect combustion chamber for damage or carbon build up whenever oil burner is removed for repairs or routine maintenance.

WARNING

Fire, burn, asphyxiation hazard. Do not start the burner unless blower access door is secured in place. Failure to follow these instructions could result in death or serious injury.

21. Circulating Air Blower

- BCL-S and BFL furnace models may be equipped with either direct drive or belt drive blower systems.
- BCL high capacity furnace models are equipped with belt drive blower systems.
- All models are equipped with PSC blower motors.

Direct Drive Blower Systems

- Direct drive blower speed adjustments are not normally required in properly sized extended plenum duct systems. Motor RPM and air CFM delivery will vary automatically to accommodate conditions within usual range of external static pressures typical of residential duct systems.
- Under-sized duct systems may require higher blower speed to obtain system temperature rise.
- Some older duct systems were not designed to provide static pressure. They typically feature special reducing fittings at each branch run and lack block ends on the trunk ducts. These systems may require modification to provide some resistance to the airflow to prevent over-amping of direct drive blower motor. Selecting a lower blower speed may correct this problem.
- Direct drive blower speeds are adjusted by changing "hot" wires to motor winding connections. Refer to wiring diagrams in Appendix B or wiring diagram label affixed to furnace.
- **Do not move neutral wire (normally white wire) to adjust blower speed.**
- Single blower speed for both heating and cooling modes may be used. Use a "piggy-back connector" accommodating both wires on a single motor tap.
- It is also acceptable to connect selected motor speed with a pigtail joined to both heating and cooling speed wires with a wire nut.
- Safety precaution against accidental disconnection of wires by vibration, secure wire nut and wires with few wraps of electricians tape.
- **Do not connect power leads between motor speeds. Always connect neutral wire to motor's designated neutral terminal.**
- If joining blower speed wiring is done in furnace junction box, tape off both ends of unused wire.
- **Do not use blower speed wires as source of power to accessories as electronic air cleaners and humidifier transformers. Unused motor taps auto-generate sufficiently high voltages to damage accessory equipment.**

Belt Drive Blower Systems

WARNING

Improper installation could result in death or serious injury. Belt drive components operate at high speeds and may snag loose clothing resulting in injury or death. Have a trained service professional perform the following instructions. Failure to follow these instructions could result in death or serious injury.

Belt drive blower systems can be modified for speed and air delivery by adjusting variable speed motor pulley and changing blower pulley.

- Adjust variable speed motor pulley by loosening 5/32 allen set screw in outer sheave. Turn outer sheave clockwise to increase blower speed, counter clockwise to reduce speed.
- Verify setscrew is tightened at one of the flat spots, failure to do so will convert the variable speed pulley to a fixed speed pulley by ruining the threads.
- Modify blower speed by changing the blower pulley. Smaller blower pulley will cause the blower to turn faster. Large pulley reduces blower speed.
- Large increases in the blower speed may increase power requirements.
- Check amperage draw of the blower motor after making changes. If amperage draw is greater than the value listed on the motor rating plate, replace with motor of higher horsepower.
- Deflection of 3/4 of an inch to 1 inch fan belt tension is necessary. Less deflection places a strain on the blower bearings and increases start up amperage draw.
- More deflection allows excess slippage and causes premature motor pulley wear.
- Automotive belt dressings are not recommended.
- Bar soap will work as belt dressing to reduce belt squeaks, etc. If using soap apply to the sides of belt only.

If operating belt drive blower at speeds above 1100 RPM, replace sintered bronze blower bearings with roller bearings.

Blower assembly in BCL (170-2/190/200/225) models with 1 HP blower is equipped with roller bearings.

WARNING

Electrical shock hazard. Turn OFF electrical power supply at service panel before opening blower access door. Failure to do so could result in death or serious injury.

NOTICE

If furnace is to be shut down for extended period of time, close oil supply valve to burner.

22. Maintenance And Service

Routine Maintenance By Home Owner

- Arrange for professional servicing of furnace by the service or installation contractor annually.
- Homeowner is to maintain air filter or filters. A dirty filter can cause furnace to over-heat, fail to maintain indoor temperature during cold weather, increase fuel consumption and cause component failure.
- Inspect, clean or replace filter monthly.
- Furnace is supplied with semi-permanent type filter. If filter is damaged, replace with filters of same size and type.
- During monthly filter inspection, inspect general condition of furnace. Watch for signs of oil leaks in vicinity of oil burner, soot forming on any external part of furnace, soot forming around joints in vent pipe, etc. If any of these conditions are present, please advise your service or installation contractor.

Annual Service By Contractor

NOTICE

Combustion chamber (firepot) is fragile. Use care when inspecting and cleaning this area

- Inspect heat exchanger periodically and clean if necessary.

WARNING

Electrical shock hazard. Turn OFF electrical power supply at service panel before service or maintenance Failure to do so could result in death or serious injury.

- If cleaning is necessary, shut off oil supply, shut off power to the furnace and remove burner.
- Use stiff brush with wire handle, brush off scale and soot from inside drum and flue pipe.
- Clean radiator, remove clean-out cap screws. Remove caps carefully to avoid tearing gaskets.
- Wire brush can be used to loosen dirt and debris on the inside surfaces of radiator. Clean out all accumulated dirt, soot and debris with a wire handled brush and an industrial vacuum cleaner.
- Before replacing clean-out caps, inspect gaskets. If gaskets are broken, remove remnants and replace with new gaskets.
- Blower motor is factory oiled and permanently sealed. **Do not lubricate.** Excess oil causes premature electric motor failure.
- Inspect blower fan. Clean if necessary.
- Oil Burner Maintenance: Follow oil burner manufacturer instructions.
- Change oil burner nozzle and oil filter annually.
- Clean and inspect venting system for signs of deterioration. Replace pitted or perforated vent pipe and fittings.
- Barometric damper should open and close freely.
- Check electrical connections to ensure tight connections. Safety controls such as the high limit controls should be tested for functionality.
- Check fan control to ensure fan on and off delay function continues to start and stop blower fan at optimal settings.

WARNING

Fire, burn, explosion, asphyxiation hazard.

- Do not start burner when excess oil has accumulated, furnace is full of vapor, or combustion chamber is very hot.
- Do not burn garbage or paper in furnace.
- Do not leave paper or rags around furnace.

Failure to follow these instructions could result in death or serious injury.

23. Operating Instructions

Before Lighting

1. Open all supply and return air registers and grilles.
2. Open all valves in oil pipes.
3. Turn on electric power supply

To Light Unit

1. Set thermostat above room temperature to call for heat. Burner should start. It may be necessary to press RESET button on primary combustion control relay.
2. There is a fan on time delay before circulating fan is energized as the furnace warms up to "FAN ON" setting on fan control.
3. Set thermostat below room temperature. Oil burner stops.
4. Air circulation blower continues to operate as long as temperature remaining in furnace is above the "FAN OFF" setting. Fan control adjustments may be altered if air at room registers is high upon blower start up or shutdown.
5. Restore thermostat setting to comfortable temperature.

To Shut Down Unit

1. Set thermostat to lowest possible setting.
2. Set manual switch (if installed) in electrical power supply line to "OFF".

APPENDIX A - CHECK OUT AND ADJUSTMENTS

Check out and adjustments

BCL and BFL furnaces may be used with following oil burners.

Beckett AF, Beckett NX and Riello 40F oil burners are for applications using indoor air for combustion only.

Sidewall venting applications utilizing outdoor air for combustion, use Beckett AFII oil burners only.

Table A-1 Beckett AF and Beckett NX Oil Burner Set-Up

Beckett AF and Beckett NX Series Oil Burners (For use with chimney vented units)						
Furnace Model	Burner Model	Nozzle	Pump Pressure	Flow Rate	Head	Static Plate
BCL90S2 BCL90ST2	AF65XN	0.75 / 80°A	100 PSIG	0.75 USGPH	F3	2- ¾ in.
BCL100S2 BCL100ST2	AF65XN	0.85 / 80°A	100 PSIG	0.85 USGPH	F3	2- ¾ in.
BCL120S2 BCL120ST2	AF65XN	1.00 / 80°A	100 PSIG	1.00 USGPH	F3	2- ¾ in.
BFL90-2 BFL90T2	AF65XN	0.75 / 80°A	100 PSIG	0.75 USGPH	F3	2- ¾ in.
BFL100-2 BFL90T2	AF65XN	0.85 / 80°A	100 PSIG	0.85 USGPH	F3	2- ¾ in.
BFL120-2 BFL120T2	AF65XN	1.00 / 80°A	100 PSIG	1.00 USGPH	F3	2- ¾ in.
BCL130S2 BCL130ST2	AF65YB	1.10 / 70°A	100 PSIG	1.10 USGPH	F6	2- ¾ in.
BCL145S2 BCL145ST2	AF65YB	1.20 / 60°A	100 PSIG	1.20 USGPH	F6	2- ¾ in.
BFL130-2 ¹ BFL130T2 ¹	AF65YB	1.10 / 70°A	100 PSIG	1.10 USGPH	F6	2- ¾ in.
BFL145-2 ¹ BFL145T2 ¹	AF65YB	1.20 / 60°A	100 PSIG	1.20 USGPH	F6	2- ¾ in.
BFL130NX2 BFL130TNX2	NX70LFHS	1.00 / 60°W	140 PSIG	1.10 USGPH	6-SLOT	N/A
BFL145NX2 BFL145TNX2	NX70LFHS	1.10 / 60°W	140 PSIG	1.20 USGPH	6-SLOT	N/A
BCL170-2	AF81WF	1.50 / 70°B	100 PSIG	1.50 USGPH	F16	2- ¾ in.
BCL190	AF81WF	1.65 / 70°B	100 PSIG	1.65 USGPH	F16	2- ¾ in.
BCL200	AF81WF	1.75 / 70°B	100 PSIG	1.75 USGPH	F16	2- ¾ in.
BCL225	AF81WF	2.00 / 70°B	100 PSIG	2.00 USGPH	F16	2- ¾ in.
¹ These models do not meet U.S. Government requirements for minimum AFUE efficiency. They are intended for Canada only.						

APPENDIX A - CHECK OUT AND ADJUSTMENTS

Table A-2 Beckett AFII Oil Burner Set-Up

Beckett AFII Series Oil Burners (For use with sidewall vented units with outdoor combustion air,)					
Furnace Model	Burner Model	Delavan Nozzle	Pump Pressure	Flow Rate	Head
BCL90SB2U2	AFII-85	0.70 / 60°A	145 PSIG	0.75 USGPH	FB3
BCL100SB2U2	AFII-150	0.80 / 60°A	145 PSIG	0.85 USGPH	FB3
BCL120SB2U2	AFII-150	0.90 / 60°A	145 PSIG	1.00 USGPH	FB3
BFL90B2U2	AFII-85	0.70 / 60°A	145 PSIG	0.75 USGPH	FB3
BFL100B2U2	AFII-150	0.80 / 60°A	145 PSIG	0.85 USGPH	FB3
BFL120B2U2	AFII-150	0.90 / 60°A	145 PSIG	1.00 USGPH	FB3

Table A-3 Riello 40F Series Oil Burner Set-Up

Riello 40F Series Oil Burners (For use with chimney vented units)						
Furnace Model	Burner Model	Delavan Nozzle	Pump Pressure	Flow Rate	Air Gate	Turbulator Setting
BCL90SRF2	40F3	0.65 / 60°W	135 PSIG	0.75 USGPH	3.5	1.0
BCL100SRF2	40F3	0.75 / 60°W	130 PSIG	0.85 USGPH	4.3	0.0
BFL90RF2	40F3	0.65 / 60°W	135 PSIG	0.75 USGPH	3.5	1.0
BFL100RF2	40F3	0.75 / 60°W	130 PSIG	0.85 USGPH	4.3	0.0

A.1 Oil Burner Air Adjustment

Consult oil burner instructions provided in furnace documents envelope for specific information concerning burner adjustments, operation and troubleshooting.

Beckett AF Burner (Chimney Vent)

Adjust air shutter by loosening locking screws. Moving air shutter, and if necessary, bulk air band.

Beckett AFII Burner (Direct Vent)

Adjust burner air supply. Loosen locking screw located on black dial to right of burner. Turn black dial clockwise to increase combustion air and counter-clockwise to decrease combustion air. Re-tighten locking screw after obtaining proper setting.

Beckett NX Burner (Chimney Vent)

Loosen splined nut on nozzle line about one turn. Turn adjustment screw clockwise to increase air and counter clockwise to decrease air. Tighten splined nut after obtaining proper setting.

Riello 40F3 Burner (Chimney Vent)

Combustion air is adjusted by removing burner cover. Loosen screws that secure air adjustment plate. Move adjusting plate to either increase or decrease combustion air. When proper air setting is achieved, retighten fixing screws.

A.2 Burner Electrodes

Adjustment of electrode tips with respect to each other, nozzle, burner head is very important to ensure smooth start-ups and to permit efficient combustion.

Beckett AF and AFII Burners

- Electrode gap: 5/32 inch.
- Distance above horizontal center-line: 5/16 inch. Older instruction sheets specify 7/16 inch. Current specification is 5/16 inch.
- Distance ahead of nozzle: 1/16 inch.
- "Z" dimension, distance from front of end cone (head) to face of nozzle should be 1-1/8 inches. If ceramic head is used, distance from end cone to nozzle face is increased to 1-3/8 inches.

Beckett NX Burners

- Electrode gap: 5/32 inch.
- Distance above horizontal center-line: 1/4 inch.
- Distance ahead of nozzle: 3/32 inch.
- Check/adjust zero calibration per Beckett NX Oil Burner Manual supplied with furnace.

Riello 40F Burners

- Electrode gap: 5/32 inch.
- Distance above horizontal center-line: 13/64 inch.
- Distance ahead of nozzle: 5/64 to 7/64 inch.

A.3 Start Up

Use following instructions to set the burner:

1. Shut off electrical power to the furnace.
2. Install oil pressure gauge to pressure port on oil pump. (Refer to oil pump specification sheet included with burner instructions).
3. Restore electrical power to furnace.
4. Start furnace and bleed all air from fuel oil lines.
5. Close purge valve and fire the unit.
6. Allow furnace to warm up to normal operating temperatures. During this time, set pump pressure in accordance with data provided in Appendix A, Table A-1 thru A-3.
7. **Chimney vented units** - Drill 1/4" test port in venting between furnace flue outlet and draft regulator (barometric damper) to take smoke readings.
8. **Sidewall vented units** - Do not drill. Use test port in the supplied appliance connector to take smoke readings.
9. When furnace has reached "steady state" (after approximately 10 minutes). Set combustion air damper to get TRACE of smoke for chimney vented units and ZERO smoke for sidewall vented units.

10. Check system temperature rise. *Temperature rise is the difference between return air temperature measured at a point near return air inlet, and supply air temperature measured near furnace outlet.*

System temperature rise is listed on furnace rating plate. If temperature rise is too high, airflow must be increased. If temperature rise is too low, slow fan down.

11. After air adjustments have been completed, recheck the over fire draft at test port on burner mounting plate shown in Figure 2. Over fire draft should be adjusted to -0.02 inches w.c.
12. Turn burner off. Observe duct thermometer in supply air stream, note temperature blower fan stops. Fan on delay and fan off delay adjustments can be made by moving FAN ON and FAN OFF settings on fan and limit control or by adjusting dipswitch settings on fan timer board as applicable.
13. Check operation of limit switch.
 - A. Shut off power to furnace.
 - B. Temporarily remove neutral wire from PSC blower motor.
 - C. Restore electrical power to furnace.
 - D. Set thermostat above room temperature.
 - E. After three or four minutes of burner operation, limit control should turn burner off.
 - F. When limit function test is complete, shut off electrical power to furnace, replace neutral wire to PSC blower motor. Restore power.
 - G. Blower fan will start up immediately. Once temperature has dropped and limit control has reset, fan will operate until fan off temperature (fan and limit control) or fan off time delay (fan timer board) is reached.
 - H. Oil burner will resume operation and continue until thermostat is satisfied.
 - I. Restore thermostat setting to comfortable temperature.

APPENDIX A - CHECK OUT AND ADJUSTMENTS

14. Set heat anticipator adjustment in thermostat (if so equipped), by removing "R" or "W" wire to thermostat. Read amperage draw between the two wires. Failure to remove one of the wires from thermostat while performing this test could burn out heat anticipator. Set heat anticipator to amperage measured.
15. Run furnace through at least three full cycles before leaving the installation, to ensure all controls are operating properly.
16. Check all joints in any positive pressure venting system for leaks before leaving the installation site

Where oil shut-off valve from oil storage tank is located.
Thermostat operation, and other related accessories.
How to operate manual reset button on primary control, and when not to push the reset button.
How and where to visually inspect venting system for leaks or other problems.
How to inspect, clean and replace air filter, and other homeowner maintenance procedures.
Who to call for emergency service and routine annual service.

A.4 Special Instructions For Units Equipped With Riello Burners

Riello specifications are listed in Table A-3.
Consult Riello Installation Instructions supplied with Burner for specific information concerning burner adjustments, operation, and trouble-shooting.

A.5 Final Check Out

Verify all safety devices and electrical components have been set for normal operation.

Verify all electrical connections are tight and wiring is secure.

Verify homeowner is informed and understands:

Where circuit breaker or fuse is located in main electrical panel.

Where furnace switch is located, and switch "on" and "off" positions if not obvious.

TABLE A-4: BCL-S DIRECT DRIVE BLOWER SET-UP

Furnace Model	Blower	Blower Set-Up				Cooling Capacity		
		0.20 in. w.c.		0.50 in. w.c.		Tons	Motor	CFM Range
		Speed	Motor	Speed	Motor			
BCL90S2	100-10R	Med-High	1/2 HP	Med-High	1/2 HP	3 - 4	1/2 HP	1000 - 1600
BCL100S2	100-10R	Med-High	1/2 HP	Med-High	1/2 HP	3 - 4	1/2 HP	1000 - 1600
BCL120S2	100-10R	High	1/2 HP	High	1/2 HP	3 - 4	1/2 HP	1000 - 1600
BCL130S2	100-10R	High	1/2 HP	High	1/2 HP	3 - 4	1/2 HP	1000 - 1600
BCL145S2	100-10R	High	1/2 HP	High	1/2 HP	3 - 4	1/2 HP	1000 - 1600
BCL90ST2	120-11T	Low	1 HP	Low	1 HP	3 - 5	1 HP	1300 - 2000
BCL100ST2	120-11T	Low	1 HP	Low	1 HP	3 - 5	1 HP	1300 - 2000
BCL120ST2	120-11T	Medium	1 HP	Medium	1 HP	3 - 5	1 HP	1300 - 2000
BCL130ST2	120-11T	Medium	1 HP	Medium	1 HP	3 - 5	1 HP	1300 - 2000
BCL145ST2	120-11T	High	1 HP	High	1 HP	3 - 5	1 HP	1300 - 2000

TIP

Formulas will assist with design of duct-work and determination of air flow delivery.

CFM = Bonnet Output / (1.085 x System Temperature Rise (ΔT))

System Temperature Rise (ΔT) = Bonnet Output / (1.085 x CFM)

Table A-5: BFL DIRECT DRIVE BLOWER SET-UP

Furnace Model	Blower	Blower Set-Up				Cooling Capacity		
		0.20 in. w.c.		0.50 in. w.c.		Tons	Motor	CFM Range
		Speed	Motor	Speed	Motor			
BFL90-2	100-10R	Med-High	1/2 HP	Med-High	1/2 HP	3 - 4	1/2 HP	1000 - 1600
BFL100-2	100-10R	Med-High	1/2 HP	Med-High	1/2 HP	3 - 4	1/2 HP	1000 - 1600
BFL120-2	100-10R	High	1/2 HP	High	1/2 HP	3 - 4	1/2 HP	1000 - 1600
BFL130-2	100-10R	High	1/2 HP	High	1/2 HP	3 - 4	1/2 HP	1000 - 1600
BFL145-2	100-10R	High	1/2 HP	High	1/2 HP	3 - 4	1/2 HP	1000 - 1600
BFL90T2	120-11T	Low	1 HP	Low	1 HP	3 - 5	1 HP	1300 - 2000
BFL100T2	120-11T	Low	1 HP	Low	1 HP	3 - 5	1 HP	1300 - 2000
BFL120T2	120-11T	Medium	1 HP	Medium	1 HP	3 - 5	1 HP	1300 - 2000
BFL130T2	120-11T	Medium	1 HP	Medium	1 HP	3 - 5	1 HP	1300 - 2000
BFL145T2	120-11T	High	1 HP	High	1 HP	3 - 5	1 HP	1300 - 2000

TABLE A-6: BCL-S BELT DRIVE BLOWER SET-UP

Furnace Model	Blower	Blower Set-Up										Cooling Capacity		
		0.20 in. w.c.					0.50 in. w.c.					Tons	Motor	CFM Range
		Pulley		Motor	Belt	Motor	Pulley		Motor	Belt	Motor			
		Motor	Blower				Motor	Blower				Motor	Blower	
BCL90S2	100-10R	3/4 x 1/2	7 x 3/4	4L420	1/3 HP	3/4 x 1/2	6 x 3/4	4L410	1/2 HP	3-4	1/2 HP	1000 - 1600		
BCL100S2	100-10R	3/4 x 1/2	7 x 3/4	4L420	1/3 HP	3/4 x 1/2	6 x 3/4	4L410	1/2 HP	3-4	1/2 HP	1000 - 1600		
BCL120S2	100-10R	3/4 x 1/2	7 x 3/4	4L420	1/3 HP	3/4 x 1/2	6 x 3/4	4L410	1/2 HP	3-4	1/2 HP	1000 - 1600		
BCL130S2	100-10R	3/4 x 1/2	6 x 3/4	4L410	1/2 HP	3/4 x 1/2	5 x 3/4	4L390	1/2 HP	3-4	1/2 HP	1000 - 1600		
BCL145S2	100-10R	3/4 x 1/2	6 x 3/4	4L410	1/2 HP	3/4 x 1/2	5 x 3/4	4L390	1/2 HP	3-4	1/2 HP	1000 - 1600		

Table A-7: BFL BELT DRIVE BLOWER SET-UP

Furnace Model	Blower	Blower Set-Up										Cooling Capacity		
		0.20 in. w.c.					0.50 in. w.c.					Tons	Motor	CFM Range
		Pulley		Motor	Belt	Motor	Pulley		Motor	Belt	Motor			
		Motor	Blower				Motor	Blower				Motor	Blower	
BFL90-2	100-10R	3/4 x 1/2	7 x 3/4	4L420	1/3 HP	3/4 x 1/2	6 x 3/4	4L410	1/2 HP	3-4	1/2 HP	1000 - 1600		
BFL100-2	100-10R	3/4 x 1/2	7 x 3/4	4L420	1/3 HP	3/4 x 1/2	6 x 3/4	4L410	1/2 HP	3-4	1/2 HP	1000 - 1600		
BFL120-2	100-10R	3/4 x 1/2	7 x 3/4	4L420	1/3 HP	3/4 x 1/2	6 x 3/4	4L410	1/2 HP	3-4	1/2 HP	1000 - 1600		
BFL130-2	100-10R	3/4 x 1/2	6 x 3/4	4L410	1/2 HP	3/4 x 1/2	5 x 3/4	4L390	1/2 HP	3-4	1/2 HP	1000 - 1600		
BFL145-2	100-10R	3/4 x 1/2	6 x 3/4	4L410	1/2 HP	3/4 x 1/2	5 x 3/4	4L390	1/2 HP	3-4	1/2 HP	1000 - 1600		

Table A-8: BCL HIGH CAPACITY MODELS BELT DRIVE BLOWER SETUP

Furnace Model	Blower	Blower Set-Up										Cooling Capacity		
		0.25 in. w.c.					0.50 in. w.c.					Tons	Motor	CFM Range
		Pulley		Motor	Belt	Motor	Pulley		Motor	Belt	Motor			
		Motor	Blower				Motor	Blower				Motor	Blower	
BCL170-2	G12	3 1/2 x 5/8	7 x 3/4	4L430	3/4 HP	3 1/2 x 5/8	7 x 3/4	4L430	3/4 HP	3-4	3/4 HP	1300 - 1550		
BCL190	G12	3 1/2 x 5/8	7 x 3/4	4L430	3/4 HP	3 1/2 x 5/8	7 x 3/4	4L430	3/4 HP	3-4	3/4 HP	1300 - 1550		
BCL200	G12	3 1/2 x 5/8	6 x 3/4	4L410	1 HP	3 1/2 x 5/8	6 x 3/4	4L410	1 HP	3-5	1 HP	1600 - 2200		
BCL225	G12	3 1/2 x 5/8	6 x 3/4	4L410	1 HP	3 1/2 x 5/8	6 x 3/4	4L410	1 HP	3-5	1 HP	1600 - 2200		

Table A-9: BCL-S & BFL AIRFLOW CHARACTERISTICS – DIRECT DRIVE

Furnace Model	Motor HP	Blower	ΔT	Motor FLA	Speed	CFM					
						External Static Pressure – Inches w.c.					
						0.20	0.25	0.30	0.40	0.50	0.60
BCL-S2 BFL-2	1/2 HP	100-10R	85°F	7.0	High	1810	1775	1740	1675	1585	1510
					Med-High	1570	1555	1540	1495	1445	1375
					Med-Low	1090	1085	1080	1070	1065	1050
					Low	710	700	700	690	665	650
BCL-ST2 BFL-T2	1 HP	120-11T	85°F	12.3 14.0 MAX	High	2188	2161	2133	2069	2016	1933
					Medium	1742	1730	1718	1702	1670	1604
					Low	1410	1410	1410	1390	1374	1326

TABLE A-10: BCL-S & BFL AIRFLOW CHARACTERISTICS – BELT DRIVE

Furnace Model	Motor HP	Motor FLA	ΔT	Blower	Blower Pulley	Motor Pulley Turns Out	CFM					
							External Static Pressure – Inches w.c.					
							0.20	0.25	0.30	0.40	0.50	0.60
BCL-S2 BFL-2	1/3 HP	5.4	85°F	100-10R	7 x 3/4	0	1425	1355	1280	1125	905	516
						2	1280	1200	1125	915	555	256
						4	1115	1020	905	530	225	11
						6	920	800	645	190	---	---
BCL-S2 BFL-2	1/2 HP	7.8	85°F	100-10R	6 x 3/4	0	1535	1475	1410	1250	1065	845
						2	1440	1370	1295	1090	880	472
						4	1320	1250	1170	970	625	319
						6	1225	1140	1040	835	435	132

Table A-11: BCL HIGH CAPACITY MODELS AIRFLOW CHARACTERISTICS – BELT DRIVE

Furnace Model	Motor HP	Motor FLA	ΔT	Blower	Blower Pulley	Motor Pulley Turns Out	CFM					
							External Static Pressure – Inches w.c.					
							0.20	0.25	0.30	0.40	0.50	0.60
BCL High Capacity	3/4 HP	13.0	85°F	G12	7 x 3/4	0	2274	2177	2080	1847	1532	1099
						2	2107	2017	1927	1712	1420	1019
						4	1939	1857	1775	1576	1308	939
						6	1772	1697	1622	1441	1196	859
BCL High Capacity	1 HP	14.0	85°F	G12	6 x 3/4	2	2601	2525	2449	2334	2164	2007
						3	2549	2474	2399	2288	2120	1967
						4	2497	2424	2350	2241	2077	1927
						5	2444	2373	2301	2194	2034	1887

APPENDIX B - WIRING DIAGRAMS

Chimney Vent Direct Drive Furnace Wiring Diagram BCL-S & BFL With Fan and Limit Control

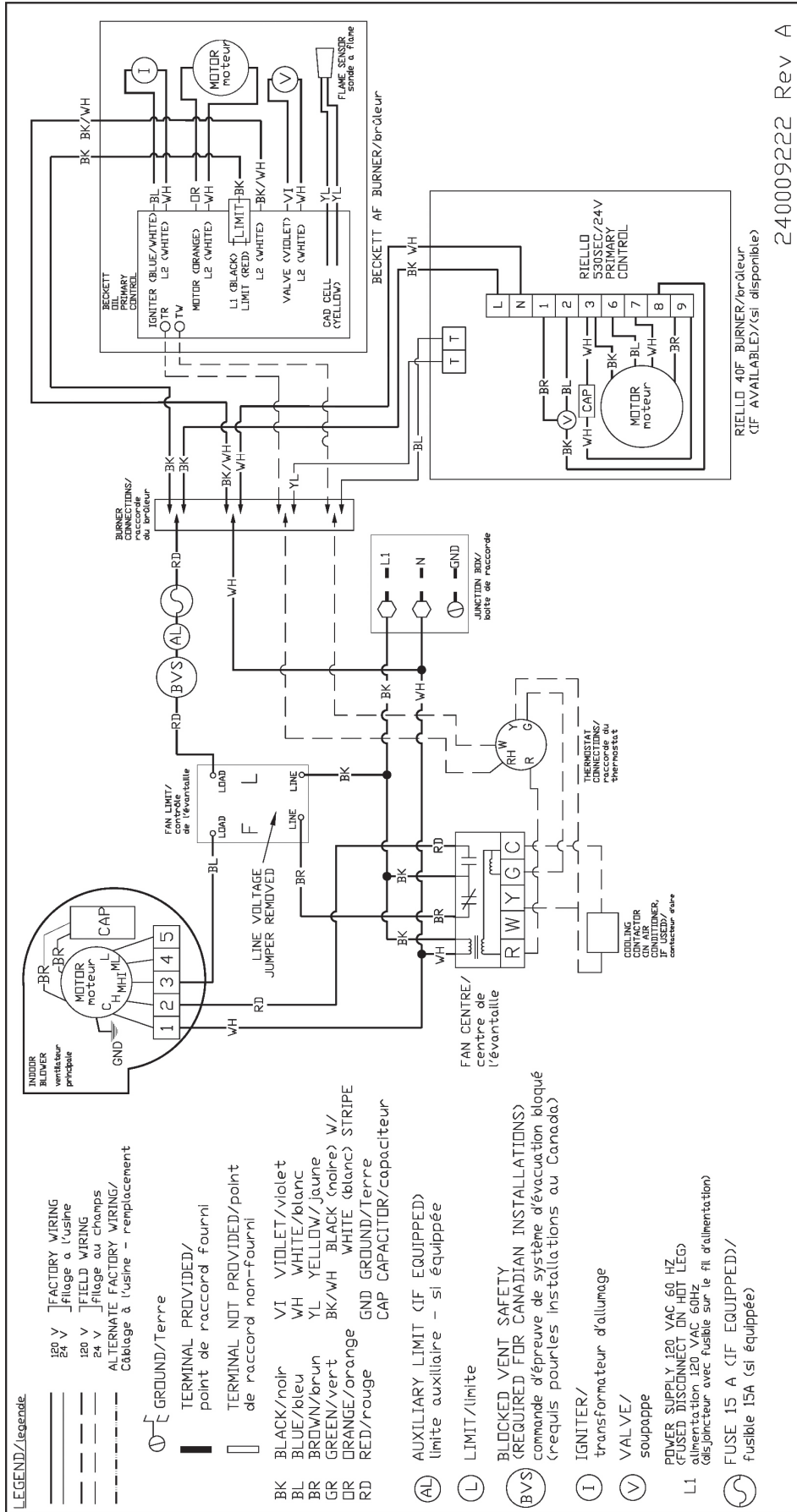

APPENDIX B - WIRING DIAGRAMS

Chimney Vent Belt Drive Furnace Wiring Diagram BCL-S & BFL & BCL High Capacity with Fan and Limit Control

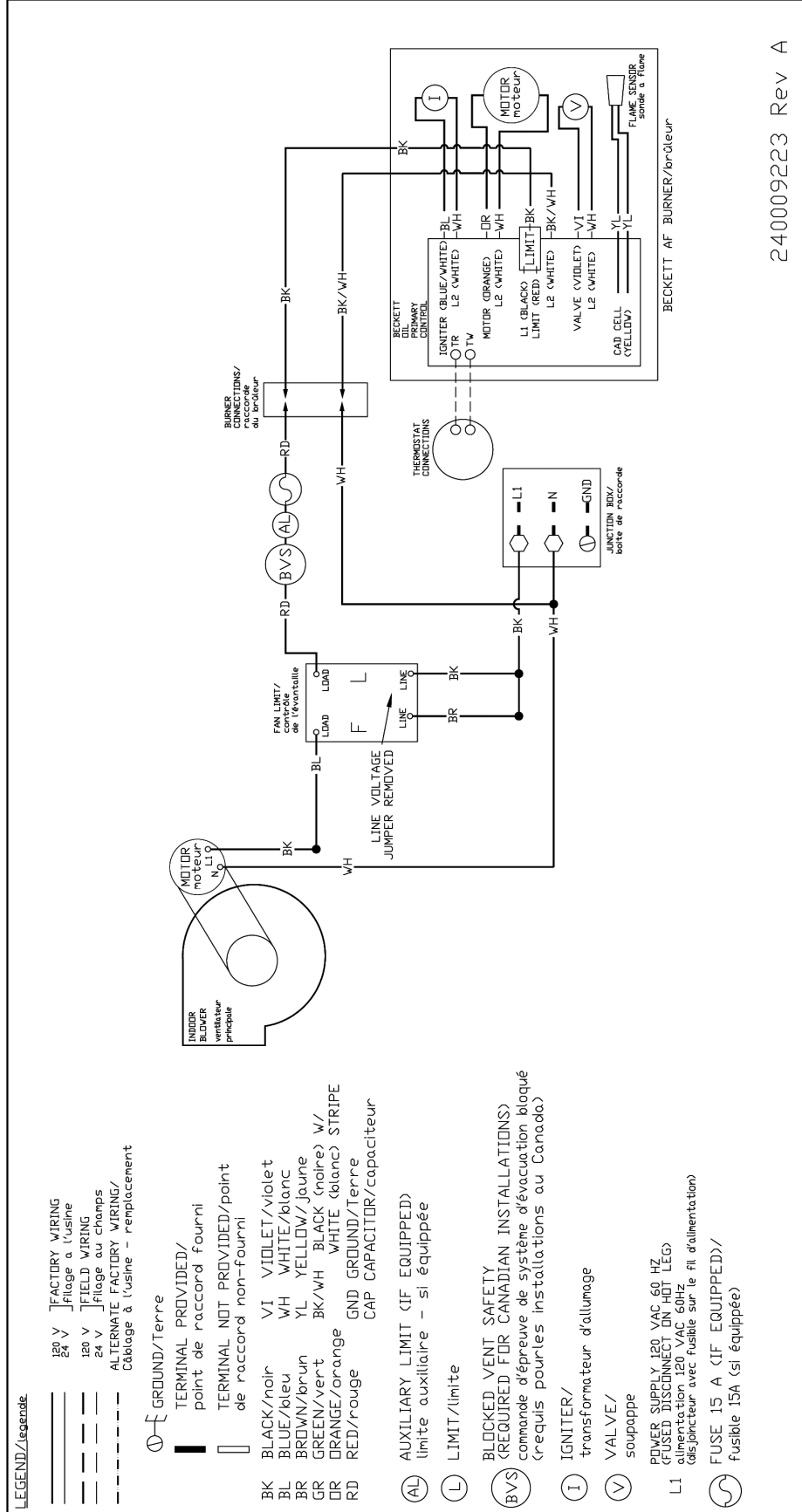

APPENDIX B - WIRING DIAGRAMS

Direct Vent Direct Drive Furnace Wiring Diagram BCL-S & BFL with Fan and Limit control

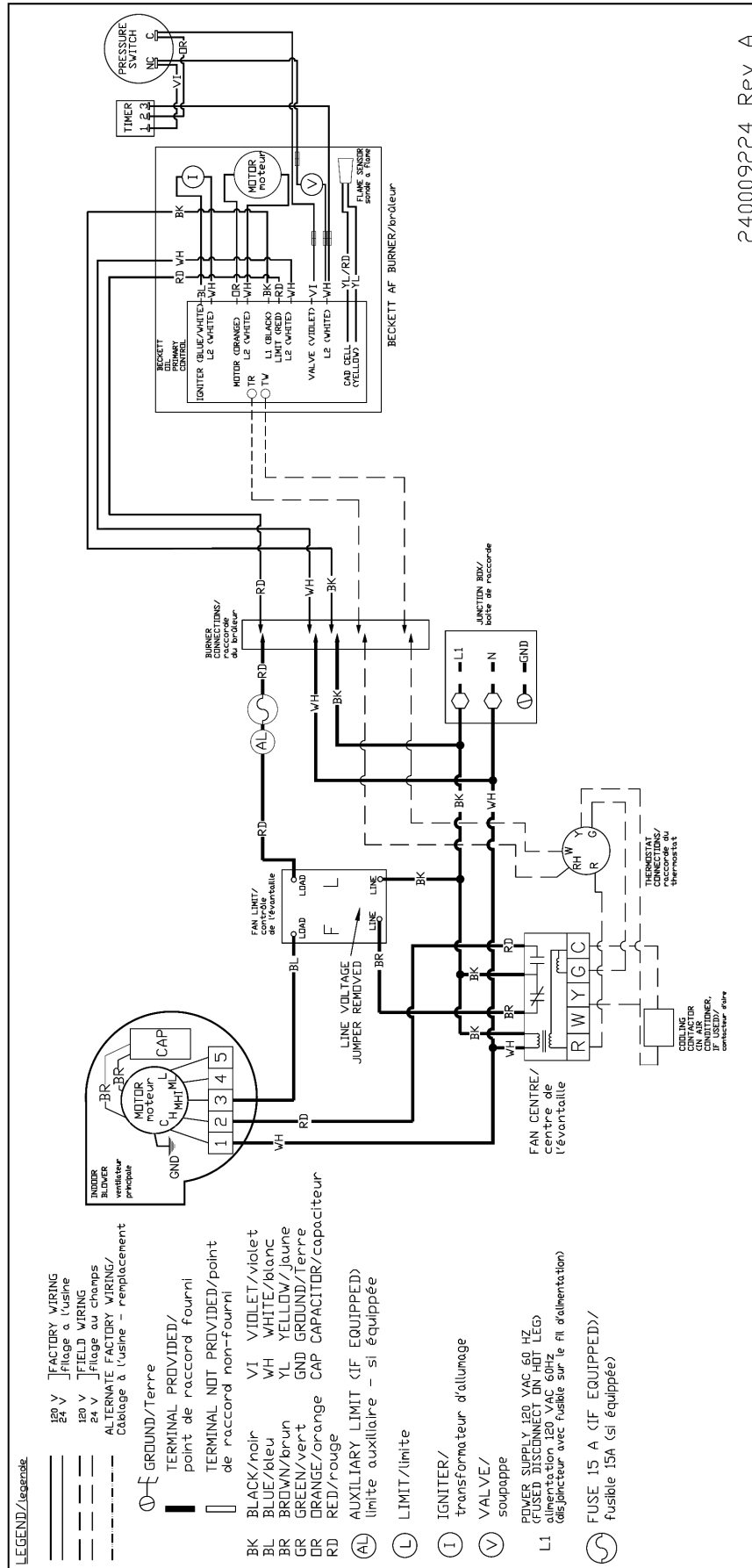

APPENDIX B - WIRING DIAGRAMS

Chimney Vent Furnace Wiring Diagram BCL-S & BFL with Fan Timer Control

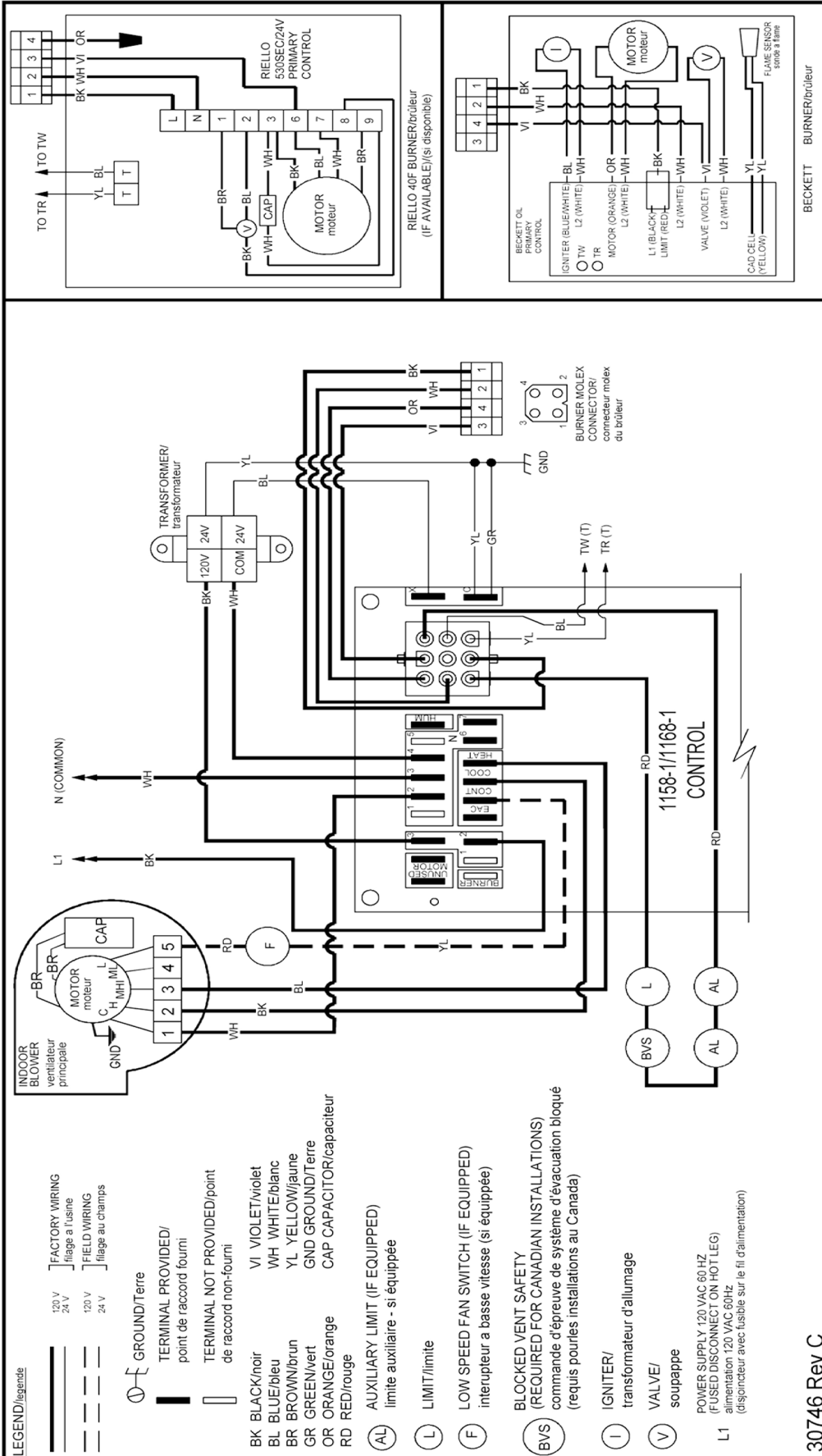

30746 Rev C

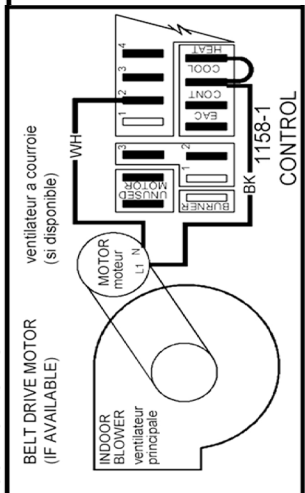
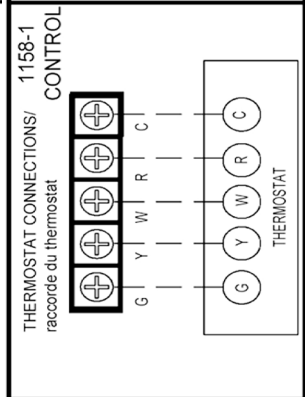

APPENDIX B - WIRING DIAGRAMS

Direct Vent Furnace Wiring Diagram BCL-S & BFL with Fan Timer Control

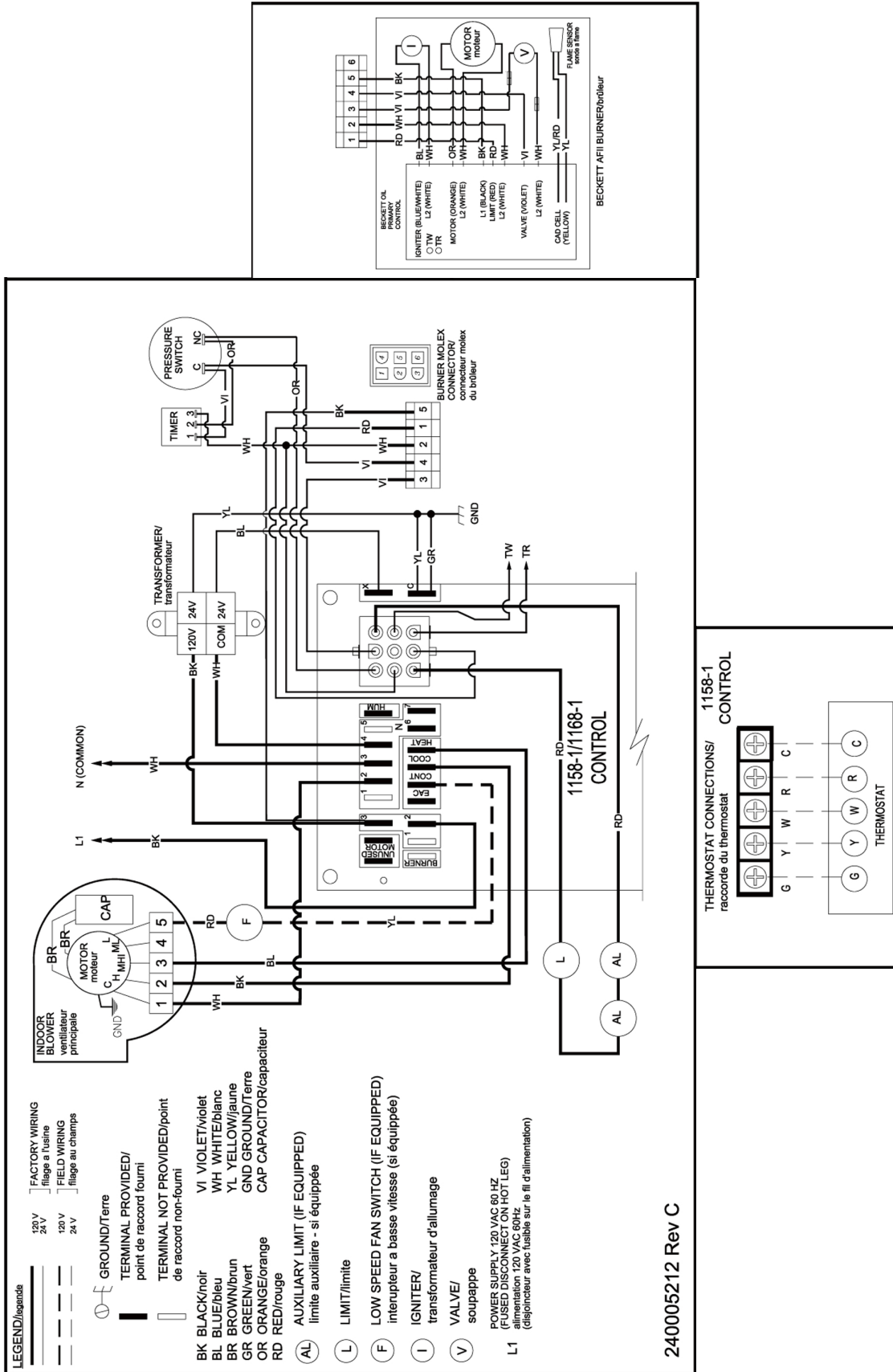

APPENDIX C - SEQUENCE OF OPERATION AND TROUBLESHOOTING

Table C-1: 1158-120 Electronic Fan Timer Board (EFT) Detailed Sequence Of Operation

Mode	Action	System Response
HEAT	Thermostat calls for heat. ("W" terminal is energized).	EFT closes the oil primary control T - T connections. Ignition system and the oil primary control start the furnace. Oil flows as long as the oil primary control senses flame. Burner motor is energized and heat "fan on" delay timing begins. When timing is complete, the circulator fan is energized at heat speed.
	Thermostat ends call for heat. ("W" terminal is de-energized).	The oil primary control is de-energized, terminating the burner cycle. Heat "fan off" delay timing begins. Length of delay depends on EFT dipswitch settings. When timing is complete, the circulator fan is de-energized. EFT returns to standby mode, (Oil primary control and circulator fan are off, unless continuous fan operation is selected at the thermostat).
	Burner fails to light.	Oil primary control locks out within lockout timing, (15 seconds). Burner motor is de-energized. (Even though thermostat is still calling for heat). If circulator fan has started, it continues through the selected heat "fan off" delay period.
	Established flame fails.	Burner motor is de-energized and oil primary control goes into recycle mode. If the selected heat "fan off" delay timing is longer than the recycle delay timing, the circulator fan continues to run through the next trial for ignition.
COOL	Thermostat begins call for cool. (G and Y terminals are energized).	Cooling contactor is energized immediately. Circulator fan is energized at cool speed.
	Thermostat ends call for cool. (G and Y terminals are de-energized).	Cooling contactor is de-energized immediately. Circulator fan turns off immediately.
FAN	Thermostat begins call for fan. (G terminal is energized).	Circulator fan is energized immediately at cooling speed.
	Thermostat ends call for fan. (G terminal is de-energized).	Circulator fan is de-energized immediately.
LIMIT	Limit switch string opens.	Oil primary control shuts off burner. Circulator fan is energized immediately at heat speed. EFT opens the oil primary control T - T connections. Circulating fan runs as long as limit string stays open. If there is a call for cooling or fan, the circulating fan switches from heating to cooling speed.
	Limit switch string closes (with existing call for heat).	EFT begins heat "fan off" delay sequence. Circulating fan turns off after the selected heat "fan off" timing. EFT re-closes the oil primary control T - T connections. Oil primary control is energized, initiating burner light off.
	Limit switch string closes (without existing call for heat).	Circulator fan turns off when heat "fan off" delay time is complete. Normal operation resumes; EFT control is in standby mode awaiting next thermostat command.
FAN	Continuous circulating fan is connected.	Circulating fan is energized when there is no call for heat, cool, or fan. If fan operation is required by a call for heat, cool, or fan, the EFT switches off the continuous fan speed tap before energizing the other fan speed.
EAC	Electronic Air Cleaner is connected.	Electronic air cleaner (EAC) connections are energized when the heat or cool speed of the circulator fan is energized. EAC connections are not energized when the optional continuous fan terminal is energized.
HUM	Humidity control is connected.	Humidifier connections are energized when the oil burner motor is energized.

C.1 Troubleshooting

WARNING

Electrical shock hazard. Only a trained, experienced service technician should perform troubleshooting procedure. Failure to do so could result in death or serious injury.

C.2 Preliminary Steps:

Consult Beckett or Riello instruction manuals provided with oil burner for specific information regarding oil burner primary control sequence of operation, diagnostics and troubleshooting.

Check diagnostic light for indications of burner condition.

NOTICE

When simulating call for heat at oil primary control, disconnect at least one thermostat lead wire from T - T terminals to prevent damage to thermostat. Neglecting this procedure may burn out heat anticipator of standard 24 vac thermostat, or cause harm to components within micro-electronic thermostat.

Before checking oil primary control, perform these preliminary checks, repair or replace controls as necessary:

- Check power supply, fuse box or breaker, any service switches, all wiring connections, and burner motor reset button (if equipped).
- Check limit switches to ensure switch contacts are closed.
- Check electrode gap and position.
- Check contacts between oil primary control and electrodes.
- Check oil supply (tank gauge).
- Check oil nozzle, oil filter, and oil valves.
- Check piping or tubing to oil tank.
- Check oil pump pressure.

C.3 Check Oil Primary Control

If the trouble does not appear to be in the burner or ignition hardware, check the oil primary control per manufacturer's instructions included with oil burner.

⚠ WARNING

Electrical shock hazard. Only a trained, experienced service technician should perform troubleshooting procedure. Failure to do so could result in death or serious injury.

Table C2: System and General Troubleshooting

Problem	Possible Cause	Remedy
Furnace will not start.	Thermostat not calling for heat	Check thermostat and adjust. Check thermostat for accuracy; if mercury switch type, it might be off level.
	No power to furnace	Check furnace switch, main electrical panel furnace fuse or circuit breaker. Look for any other hand operated switch, such as old poorly located furnace switch, which was not removed during furnace replacement.
	Thermostat faulty	Remove thermostat wires from oil primary control terminals T-T. Place a jumper across T-T. If furnace starts, replace thermostat, thermostat sub-base (if equipped), or both.
	Oil primary control faulty	Check reset button on oil primary control. Remove thermostat wires from oil primary control terminals T - T. Check for 24V across T -T. If no voltage is present, check for 115V to oil primary control. If 115V is present, refer to oil primary control documentation provided with oil burner.
	Photo Cell wiring shorted or room light leaking into photo cell compartment	Check photo cell (cad cell) wiring for short circuits. Check for room light leaking into cad cell compartment. Repair light leak if necessary.
	Open safety switch	Check for open limit or auxiliary limit. Check internal wiring connections; loose connectors, etc.
Furnace will not start without first pushing oil primary control reset button. (Happens on frequent basis)	No fuel oil	Check fuel oil supply. Check all hand operated fuel oil valves are in open position. Fill oil storage tank if necessary.
	Clogged nozzle	Replace nozzle with high quality replacement. Use rating plate or Tables in Appendix A as a guide.
	Clogged oil filter	Replace oil tank filter or in-line filter if used.
	Low oil pump pressure	Connect pressure gauge to oil pump. Adjust pump pressure, or replace oil pump if necessary. Verify erratic pressure readings are not caused by defective fuel oil line.
	Air getting into fuel oil lines, or fuel oil line dirty, clogged, or in some manner defective	Check fuel oil lines. Replace any compression fittings found with high quality flared fittings. Check for signs of oil leaks. Any oil leak is potential source of air or contaminants.
	Defective burner motor	Check burner motor. If burner motor is cutting out on over-load, determine why. Replace if necessary.

APPENDIX C - SEQUENCE OF OPERATION AND TROUBLESHOOTING

Table C-2: System and General Troubleshooting continued

Problem	Possible Cause	Remedy
Furnace starts, but cuts out requiring manually resetting oil protector reset button.	Photo Cell (Cad Cell) defective.	If cad cell is dirty, clean it. Determine why cad cell is getting dirty. If cad cell is poorly aimed, realign it. NOTE: Photocell should have resistance of 100 K Ω in absence of light; maximum of 1500 Ω in presence of light. Verify room light is not leaking into the cad cell compartment. (See diagnostic light section).
Furnace starts, but cuts out requiring manually resetting oil protector reset button.	No fuel oil.	Check fuel oil supply. Check that all hand operated fuel oil valves are in the open position. Fill oil storage tank if necessary.
	Clogged nozzle.	Replace nozzle with high quality replacement. Use rating plate or Tables in Appendix A as a guide.
	Clogged oil filter.	Replace oil tank filter or in-line filter if used.
	Low oil pump pressure.	Connect pressure gauge to oil pump. Adjust pump pressure, or replace oil pump if necessary. Verify erratic pressure readings are not caused by defective fuel oil line.
	Air getting into fuel oil lines, or fuel oil line dirty, clogged, or in some manner defective.	Check fuel oil lines. Replace any compression fittings found with high quality flared fittings. Check for any signs of oil leaks. Any oil leak is a potential source of air or contaminants.
	Defective burner motor.	Check burner motor. If burner motor is cutting out on over-load, determine why. Replace if necessary.
	Water or contaminants in oil.	Drain fuel oil storage tank; replace fuel oil. (Consult with fuel oil supplier).
Frozen oil line.	Gently warm oil line. Insulate oil line. (Outdoor piping size may require increased diameter).	
Oil burner sputtering at nozzle	Electrodes out of adjustment or defective.	Check electrode settings. Check electrodes for dirt build-up or cracks in porcelain.
	Poor igniter connections or defective igniter.	Check contacts between the igniter and electrodes. If OK, replace the igniter
	Fuel oil filter clogged.	Replace fuel oil storage tank filter and / or fuel oil in-line filter.
	Defective oil pump.	Check burner motor and / or fuel oil pump coupling. Check oil pump pressure. Replace fuel oil pump if necessary.
	Fuel oil line partially clogged or contains air.	Bleed air from oil line. If problem persists, replace oil line.
Excessive fuel oil consumption.	System temperature rise too high.	System temperature rise should not exceed 75°F. Check for clogged air filters. Check blower fan for excess dirt build-up or debris. Speed up blower fan if necessary.
	Poor "fan off" delay timing selection, (fan stops too soon).	Check "fan off" delay timing setting. Use duct thermometer in supply air plenum take-off or first few inches of supply air trunk duct. Fan should shut off at 90° - 100°F. Manipulate dip switch settings or adjust "fan off" temperature setting as applicable to come as close as possible to this "fan off" temperature.
	Fuel oil leak.	Check fuel oil line for leaks. Repair or replace if necessary.
	Stack temperature too high.	Check stack temperature. Stack temperatures will normally range from 400° to 500°F. Check draft regulator. Draft should be set to -0.02 in. w.c.
	Thermostat improperly adjusted or in poor location.	Check thermostat heat anticipator setting against measured amperage draw. Increase heat anticipator setting if necessary. If thermostat is being influenced by drafts, sunlight, duct work, etc., relocate to suitable location.

APPENDIX C - SEQUENCE OF OPERATION AND TROUBLESHOOTING

Table C-2: System and General Troubleshooting continued

Problem	Possible Cause	Remedy
Too much smoke.	Insufficient combustion air adjustment at oil burner, or improper draft pressure.	Adjust oil burner combustion air band and draft regulator to gain highest practical CO ₂ or lowest practical O ₂ content in flue gases. See Burner Set Up.
	Heat exchanger partially clogged.	Check for soot build-up in heat exchanger flue passages, especially in outer radiator.
Soot building up on blast tube (end coning).	Poor alignment between oil burner blast tube and fire pot.	Check alignment. Blast tube should be centered with fire pot burner opening. Oil burner head should be ¼ inch back from inside surface of fire pot.
	Flame impingement caused by incorrect nozzle angle.	Check nozzle size and angle. (See Appendix A). Check distance from head to inside surface of fire pot.
	Defective fire-pot	Check fire-pot. Repair or replace.
Furnace will not warm home to desired temperature.	Airflow blocked or dirty air filter.	Clean or replace air filter.
	Thermostat adjustments or location.	Check thermostat heat anticipator setting against measured amperage draw. Increase heat anticipator setting if necessary. If thermostat is being influenced by drafts, sunlight, duct work, etc., relocate to suitable location.
	Insufficient airflow.	Check all dampers. Open closed dampers including registers in unused rooms. Check system temperature rise. If temperature rise is too high, speed up blower fan.
	Defective high limit control.	Test high limit function of all limit switches. Use duct thermometer to verify accuracy of limit control. Check for obstructions to airflow around limit switch bimetal elements. Replace control if necessary.
	Under-sized nozzle.	Check nozzle. If problem is not caused by air flow problems, use larger nozzle, if permitted by rating plate.
	Blower fan motor stopping intermittently on overload.	Check blower fan motor amperage draw. Check motor ventilation ports, clean if necessary. Replace motor if necessary.
	Burner motor stopping intermittently on overload.	Check burner motor. Replace if necessary.
Home does not heat evenly	Improper distribution of heat.	This is not likely to be a furnace problem. Balance duct system.
Supply air temperature too hot.	Airflow blocked or dirty air filter.	Clean or replace air filter.
	Insufficient airflow.	Check all dampers. Open closed dampers including registers in unused rooms. Check system temperature rise. If temperature rise is too high, speed up blower fan.
Supply air temperature too cool.	Excess airflow.	Check system temperature rise. Slow down blower fan if necessary.
	Excessive duct losses.	Check supply air ductwork. Seal leaky joints and seams. Insulate ductwork if necessary.
Supply air temperature too cool during first moments of furnace cycle.	Fan control "fan on" setting too low.	Increase "fan on" temperature settings on fan and limit control or "fan on" dispswitch settings on fan timer board. Register air deflectors may help.
	Excessive duct losses.	Check supply air ductwork. Seal leaky joints and seams. Insulate ductwork if necessary.

Model BCL High Capacity Diagram

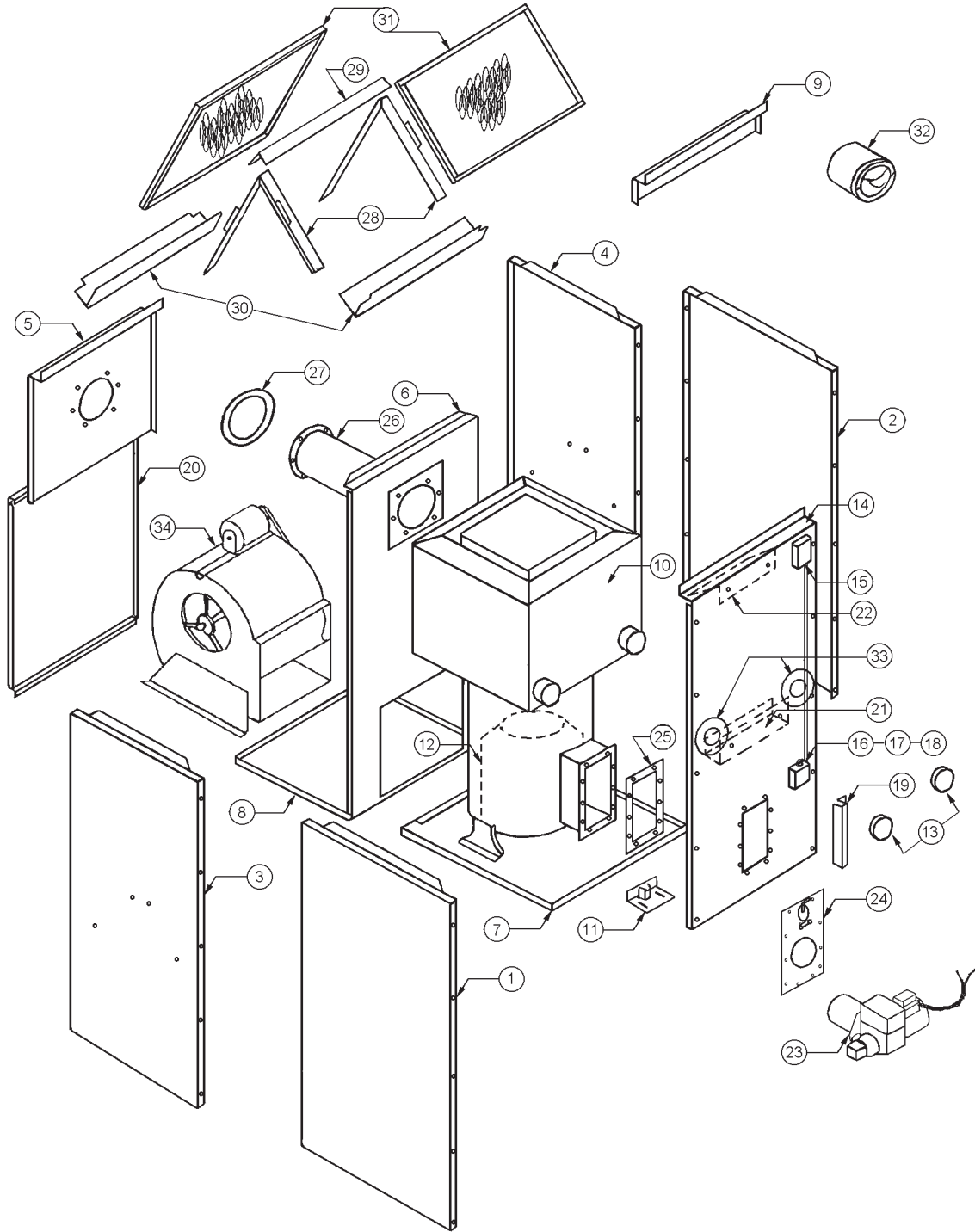

PARTS LISTING

PARTS LISTING: BCL 170-2/190/200/225 HIGH CAPACITY MODELS

Ref. No.	Description	Part No.
1	Left Side Panel Heating Compartment	29040AD
2	Right Side Panel Heating Compartment	29040AD
3	Left Side Panel Blower Compartment	29048AD
4	Right Side Panel Blower Compartment	29047AD
5	Upper Rear Panel Blower Compartment	29062AD
6	Blower Partition Panel	29052AD
7	Base Panel Assembly Heating Compartment	29043
8	Base Panel Assembly Blower Compartment	29056
9	Plenum Edge Panel Heating Compartment	29045AD
10	Heat Exchanger Assembly (Prior to ser#BCUL66150 use 1018B4)	550001632
11	Firepot Bracket Assembly	29225
12	Replacement Firepot	27000WP
13	Cleanout Pipe Cap (2 per unit)	240007841
	Cleanout Cap Gasket (2 per unit)	240006333
14	Front Panel	29220AD
	Logo Bezel	28479
	Logo Label	28563
15	Fan & Limit Control, 8" Insertion, Set @ 200° F	29041
16	Junction Box	21318
17	Fuse Holder	27089
18	Fuse, ABC-15	2200096
19	Wire Retainer Channel	27510
20	Blower Access Door	29053AD
	Door Handle – PS-18	28673
21	Front Panel Baffle	3022140A
22	Top Front Panel Baffle	29223
23	Oil Burner assembly Beckett AF81WF	29597
	Burner Motor 1/7 HP 3450 RPM PSC	29689
	Beckett Cleancut Oil Pump A2EA6520	29688
	Solid State Ignitor FRANCE 10SAY-04	29522
	Primary Combustion Control 7505B1500	240008816
	Air Tube Combination AF81WF	29530
	Flame Retention Head (F16)	29531
24	Oil Burner Mounting Plate Assembly	109007674
	Sight Glass	29876
	Sight Glass Gasket (2 per unit)	29870
	Sight Glass Retainer	29850
25	Pouch Gasket	2080175
26	Flue Pipe Assembly	240008174
27	Flue Pipe Gasket (2 per unit)	2080181
28	Filter Rail Assembly (2 per unit)	29054
29	Top Filter Support	29063
30	Filter Support Front & Rear (2 per unit)	29055
31	Filter, 20" X 25" X1" Permanent (2 per unit)	2180024
32	Draft Regulator (7")	12401
33	Clean-out Gasket Retainer (2 per unit)	29161
	Cleanout Gasket (2 per unit)	29163

PARTS LISTING

PARTS LISTING: BCL 170-2/190/200/225 HIGH CAPACITY MODELS

Ref. No.	Description	Part No.
34	Blower Assembly, 3/4 HP	8756B2
	Blower Housing and Wheel, G12	2040008
	Blower Motor, 3/4 HP Single Speed	28007
	Motor Pulley, 3 1/2 X 5/8 Adjustable With Keyway	19779
	Blower Pulley, 7 X 3/4	2240008
	Fan Belt, 4L430	2240022
	Blower Base Feet LH	8173B2
	Blower Base Feet RH	8173B1
	Blower Base Feet Rubber Grommet (4 required)	26415
34	Blower Assembly, 1 HP	29217
	Blower Housing and Wheel, G12 With Ball Bearings	29222
	Blower Motor, 1 HP Single Speed	102000156
	Motor Pulley 3 1/2 X 5/8 Adjustable With Keyway	19779
	Blower Pulley 6 X 3/4	2240006
	Fan Belt 4L410	2240020
	Blower Base Feet LH	8173B2
	Blower Base Feet RH	8173B1
	Blower Base Feet Rubber Grommet (4 required)	26415
*	Blocked Vent Safety Switch Kit Complete	30673
*	Blocked Vent Safety Switch - Replacement Switch Only	30660
*	Flue Pipe for Blocked Vent Safety Switch	30657

PARTS LISTING

Model BCL-S Diagram (Fan and Limit Control Shown)

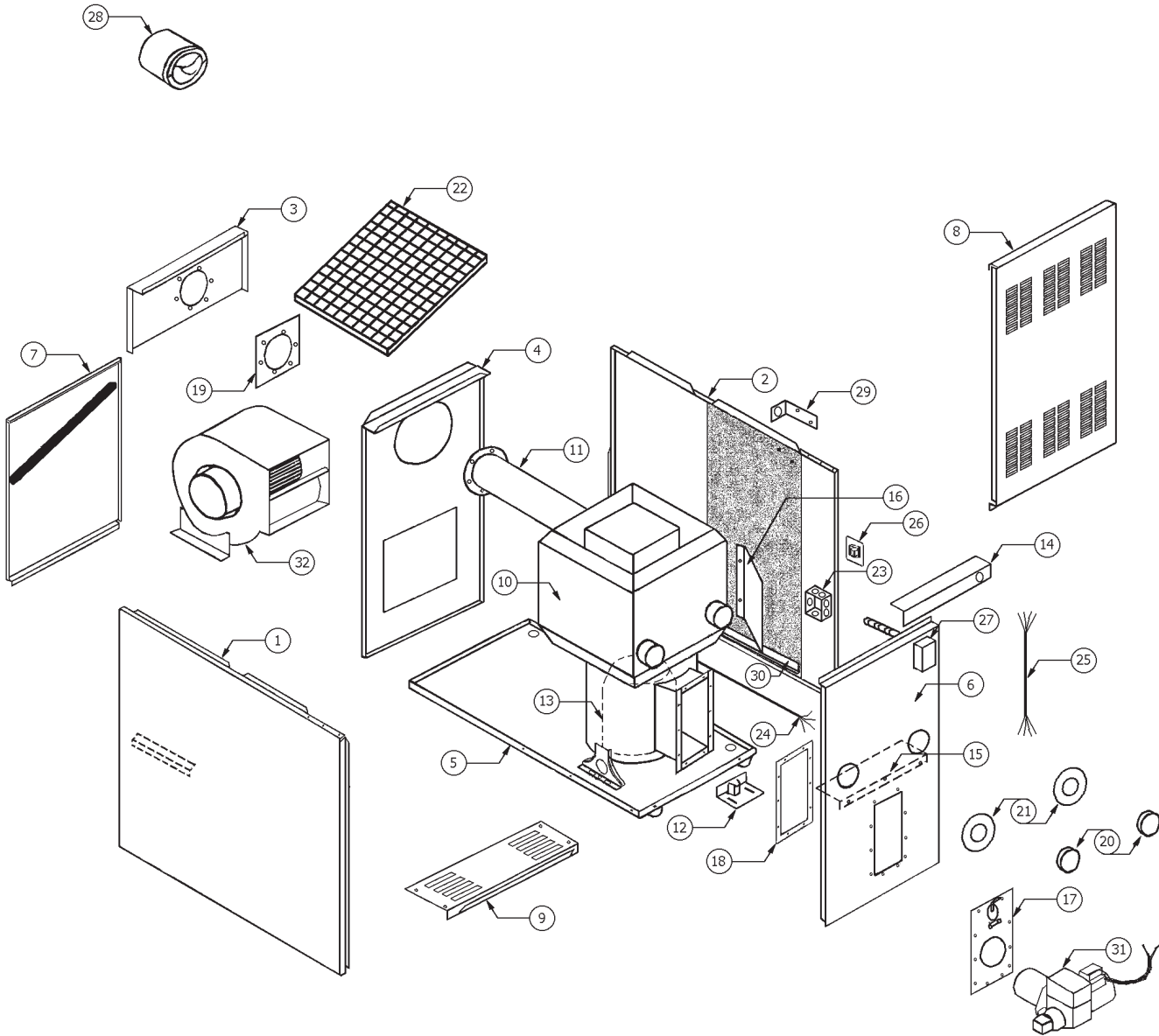

PARTS LISTING

PARTS LISTING: CHIMNEY VENT MODELS BCL-(S2, SRF2)

Ref. No.	Description	Part No.
1	Left Side Panel Assembly	28423AD
2	Right Side Panel Assembly	28422AD
3	Upper Rear Panel	26048AD
4	Blower Division Panel Assembly	550002146
5	Base Panel Assembly	28459
6	Inner Front Panel (for use with Fan and Limit Control)	28425
	Inner Front Panel (for use with Fan Timer Control)	109009279
7	Blower Access Door	26586AD
	Door Handle – PS-18	28673
	Filter Gasket	28549
8	Front Door Panel	21338AD
	Door Handle	28673
	Logo Bezel	28479
	Logo Label	28563
9	Top Front Panel	26017AD
10	Heat Exchanger Assembly for Beckett AF Burner	550001630
	Heat Exchanger Assembly for Riello Burner	550001631
11	Flue Pipe Assembly	28497
12	Firepot Bracket Assembly	4141185A
13	Replacement Combustion Chamber 9200C for Beckett AF Burner	8823B1
	Replacement Combustion Chamber 27000B for Riello Burner	27000WP
14	Top Front Baffle	21485
15	Inner Front Baffle	21425
16	Right Side Panel Baffle	21344
17	Oil Burner Mounting Plate Assembly	109007674
	Sight Glass	29876
	Sight Glass Gasket (2 per unit)	29870
	Sight Glass Retainer	29850
18	Pouch Gasket	2080175
19	Flue Pipe Gasket (2 per unit)	21994
20	Cleanout Pipe Cap (2 per unit)	240007841
	Cleanout Cap Gasket (2 per unit)	240006333
21	Clean-out Gasket Retainer (2 per unit)	29161
	Cleanout Gasket (2 per unit)	29163
22	Air Filter – 20 x 25 x 1 (Permanent)	2180024
Items 23-27 for use on models with Fan and Limit Control		
23	Junction Box	21318
	Fuse ABC 15 Amp Slow Blow (Not all models)	2200096
	Fuse Holder HKP-HH (Not all models)	27089
24	Wire Harness Blower Direct Drive	27273
	Wire Harness Blower Belt Drive	27272
25	Wire Harness Fan & Limit	29422
26	Fan Centre	27740
	27740 Replacement Relay 9400-04Q1999	27767
27	Fan & Limit Control 11" or 11½" Insertion, 230° F	18002

PARTS LISTING

PARTS LISTING: CHIMNEY VENT MODELS BCL-(S2, SRF2) conti.

Ref. No.	Description	Part No.
Items in this group for use on models with Electronic Fan Timer Control		
*	Control Panel	30010
	Control Panel Cover	29654
	Wire Harness Blower Motor Direct Drive	29690
	Wire Harness Blower Motor Belt Drive	29691
	Wire Harness Fan Timer Control (Chimney Vent)	29364
	Wire Harness Transformer and Power Supply	29751
	Fan Timer Control 1158-120 UTEC	29388
	Transformer 120/24V, 40A	240005330
	Limit Control 36T01B3-612718, L200°F, 3" Insertion	240010427
28	Draft Regulator 6"	12240
29	Fan & Limit Support / Insulation Retainer	26973
30	Side Panel Insulation Retainer (2 per unit)	26047
31	Beckett Oil Burner AF65XN (0.75, 0.85, 1.00 GPH) Wired for Fan and Limit Control	29592
	Beckett Oil Burner AF65XN (0.75, 0.85, 1.00 GPH) Wired for Fan Timer Control	240010428
	Burner Motor 1/7 HP 3450 RPM PSC	29689
	Beckett Clean-cut Oil Pump A2EA6520	29688
	Solid State Ignitor FRANCE 10SAY-04	29522
	Primary Combustion Control 7505B1500	240008816
	Air Tube Combination AF65XN	11986
	Flame Retention Head (F3)	1050003
31	Beckett Oil Burner AF65YB (1.10, 1.20 GPH) Wired for Fan and Limit Control	29594
	Beckett Oil Burner AF65YB (1.10, 1.20 GPH) Wired for Fan Timer Control	2400010429
	Burner Motor 1/7 HP 3450 RPM PSC	29689
	Beckett Clean-cut Oil Pump A2EA6520	29688
	Solid State Ignitor FRANCE 10SAY-01	29522
	Primary Combustion Control 7505B1500	240008816
	Air Tube Combination AF65YB	20877
	Flame Retention Head (F6)	1050004
31	Riello 40F3 Oil Burner (0.75, 0.85 GPH)	27343
32	Blower Assembly, Complete, Direct Drive, 1/2 HP	20643
	Blower Housing and Wheel, 100-10R DD	30624
	Blower Motor, 1/2 HP, 4-Speed	102000131
	Motor Mounting Band – TR5868	17811
	Motor Mount Arms – 10-10 DD Blower (3 per unit)	26251
	Motor Run Capacitor, 10 mfd @ 370 vac	27743
	Capacitor Strap	27761
	Blower Base Feet (2 per unit)	109005826
	Blower Base Feet Rubber Grommet (4 per unit)	26415

* = Not Shown

PARTS LISTING

PARTS LISTING: CHIMNEY VENT MODELS BCL (S2, SRF2) conti.

32	Blower Assembly, Complete, Belt Drive 1/3 HP	6033C6
	Blower Housing and Wheel, 100-10R BD	30625
	Blower Motor 1/3 HP SS	10200153
	Motor Pulley 3 1/4 X 1/2 Adjustable	2240001
	Blower Pulley 7 X 3/4	2240008
	Fan Belt 4L420	2240021
	Blower Base Feet (2 per unit)	109005826
	Blower Base Feet Rubber Grommet (4 per unit)	26415
32	Blower Assembly, Complete, Belt Drive 1/2 HP	6033C7
	Blower Housing and Wheel, 100-10R BD	30625
	Blower Motor 1/2 HP SS	102000154
	Motor Pulley 3 1/4 X 1/2 Adjustable	2240001
	Blower Pulley 6 X 3/4	2240006
	Fan Belt 4L410	2240020
	Blower Base Feet (2 per unit)	109005826
	Blower Base Feet Rubber Grommet (4 per unit)	26415
*	Blocked Vent Safety Switch Kit Complete	30674
*	Blocked Vent Safety Switch - Replacement Switch Only	30660
*	Flue Pipe for Blocked Vent Safety Switch	30656

Ref. No. PARTS LISTING: CHIMNEY VENT MODELS BCL-ST2

Part No.

All parts are the same as listed on the previous pages for Model BCL-S2 except where noted below.

4	Blower Division Panel Assembly	29107
24	Wire Harness Blower Direct Drive	27275
25	Wire Harness Fan & Limit	26838
26	Fan Centre Assembly	26857
	Replacement Relay R8228B1012B	26854
	Fuse ABC 15 Amp Slow Blow	2200096
	Fuse Holder HKP-HH BCL	27089
32	Blower Assembly, Complete, Direct Drive, 1 HP	26812
	Blower Housing and Wheel, 120-11T	240006678
	Blower Motor, 1 hp 3 Speed	102000157
	Motor Mounting Band – TR5868	17811
	Motor Mount Arms – TR7624B (3 per unit)	240006535
	Motor Run Capacitor, 20 mfd @ 370 vac	27745
	Capacitor Strap	27761
	Blower Base Feet LH	26013
	Blower Base Feet RH	26012
	Terminal Block #EE8-201	26833
Blower Base Feet Rubber Grommet (4 required)	26415	

* = Not Shown

PARTS LISTING: DIRECT VENT MODELS BCL-SB2U2

Ref. No.	Description	Part No.
All parts are the same as listed on the previous pages for Model BCL-S2 except where noted below.		
10	Heat Exchanger Assembly for Beckett AFII Burner	550001631
13	Replacement Combustion Chamber 27000B for Beckett AFII Burner	27000WP
18	Pouch Gasket (Second gasket required for Direct Vent)	2080175
31	Beckett Oil Burner AFII 150 Wired for Fan and Limit Control	30743
	Beckett Oil Burner AFII 150 Wired for Fan Timer Control	240010452
	Burner Motor 1/7 HP 3450 RPM PSC	28907
	Beckett Clean-cut Oil Pump A2EA6520	29688
	Solid State Ignitor FRANCE 10SAY-04	28558
	Primary Combustion Control 7505P1530	
	Air Tube Combination FBX80HGXS	28561
	Flame Retention Head (FB3)	28533
*	Pressure Switch -0.33" WC	30734
*	10 Second Bypass Timer GPS00C9X10	30699
*	Appliance Vent Adapter 6" Breech to 4" Vent	240006905
*	Combustion Air Intake Collar 4" for AFII Burner	109005950
*	Wire Harness Fan Timer Control (Direct Vent)	30745

* = Not Shown

PARTS LISTING

Model BFL Diagram (Fan and Limit Control Shown)

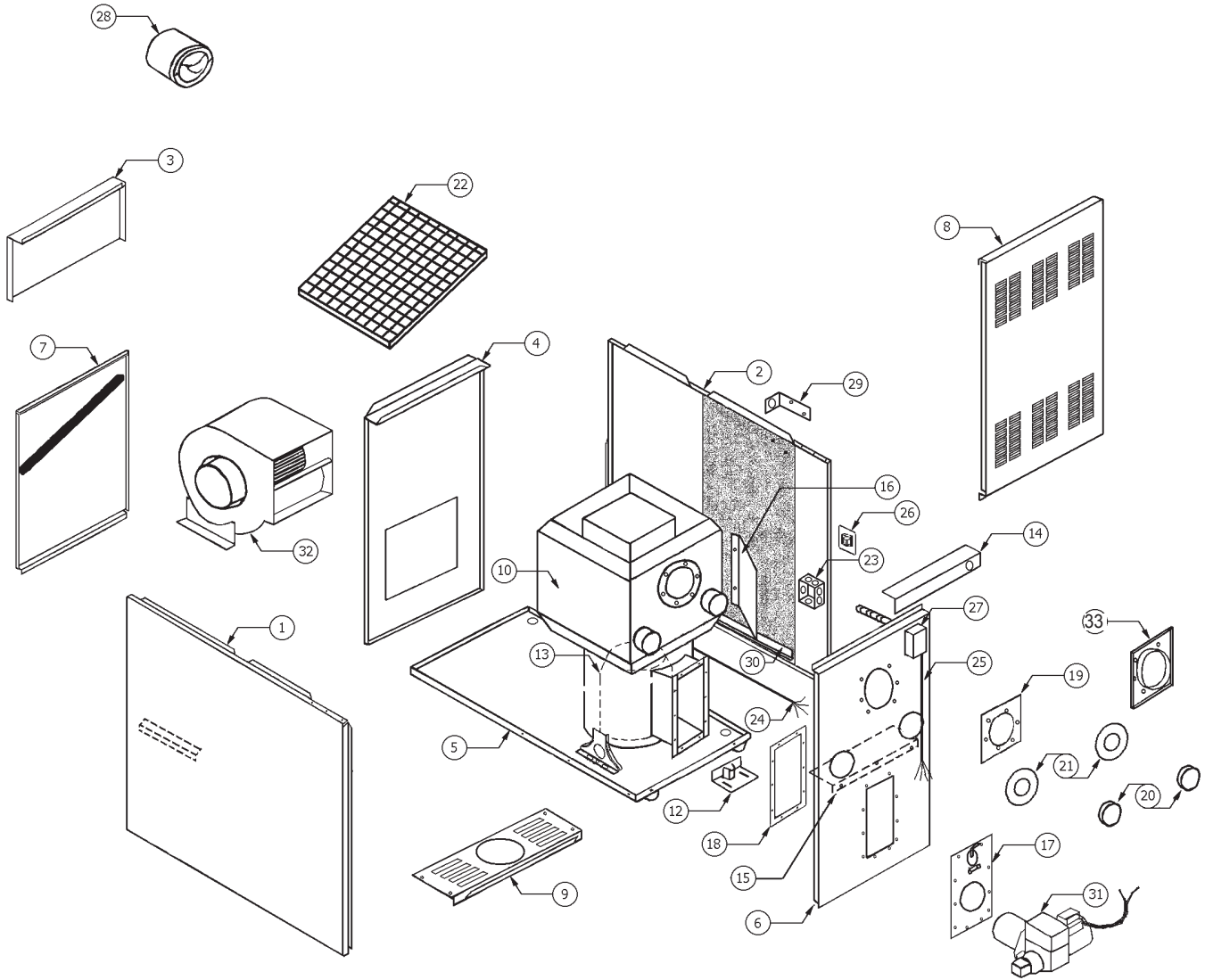

PARTS LISTING

PARTS LISTING: CHIMNEY VENT MODELS BFL-(2,RF2)

Ref. No.	Description	Part No.
1	Left Side Panel Assembly	28423AD
2	Right Side Panel Assembly	28422AD
3	Upper Rear Panel	21421AD
4	Blower Division Panel Assembly	28469
5	Base Panel Assembly	28459
6	Inner Front Panel (for use with Fan and Limit Control)	28428
	Inner Front Panel (for use with Fan Timer Control)	109009280
7	Blower Access Door	26586AD
	Door Handle – PS-18	28673
	Filter Gasket	28549
8	Front Door Panel	21338AD
	Door Handle	28673
	Logo Bezel	28479
	Logo Label	28563
9	Top Front Panel	21437AD
10	Heat Exchanger Assembly for Beckett AF or NX Burner	550001633
	Heat Exchanger Assembly for Riello Burner	550001634
12	Firepot Bracket Assembly	4141185A
13	Replacement Combustion Chamber 9200C for Beckett AF or NX Burner	8823B1
	Replacement Combustion Chamber 27000B for Riello Burner	2700WP
14	Top Front Baffle	21485
15	Inner Front Baffle	21425
16	Right Side Panel Baffle	21344
17	Oil Burner Mounting Plate Assembly	109007674
	Sight Glass	29876
	Sight Glass Gasket (2 per unit)	29870
	Sight Glass Retainer	29850
18	Pouch Gasket	2080175
19	Flue Collar Gasket	21994
20	Cleanout Pipe Cap (2 per unit)	240007841
	Cleanout Cap Gasket (2 per unit)	240006333
21	Clean-out Gasket Retainer (2 per unit)	29161
	Cleanout Gasket (2 per unit)	29163
22	Air Filter – 20 x 25 x 1 (Permanent)	2180024
Items 23-27 for use on models with Fan and Limit Control		
23	Junction Box	21318
	Fuse ABC 15 Amp Slow Blow (Not all models)	2200096
	Fuse Holder HKP-HH (Not all models)	27089
24	Wire Harness Blower Direct Drive	27273
	Wire Harness Blower Belt Drive	27272
25	Wire Harness Fan & Limit	29422
26	Fan Center	27740
	27740 Replacement Relay 9400-04Q1999	27767
27	Fan & Limit Control 11" or 11 ½" Insertion, 190° F	12356

PARTS LISTING

PARTS LISTING: CHIMNEY VENT MODELS BFL-(2.RF2) conti.

Ref. No.	Description	Part No.
Items in this group for use on models with Electronic Fan Timer Control		
*	Control Panel	30010
	Control Panel Cover	29654
	Wire Harness Blower Motor Direct Drive	29690
	Wire Harness Blower Motor Belt Drive	29691
	Wire Harness Fan Timer Control (Chimney Vent)	29364
	Wire Harness Transformer and Power Supply	29751
	Fan Timer Control 1158-120 UTEC	29388
	Transformer 120/24V, 40VA	240005330
	Limit Control 60T11,L155°F, BOF (Black Oxide Finish)	30071
28	Draft Regulator 6"	12240
29	Fan & Limit Support / Insulation Retainer	26973
30	Side Panel Insulation Retainer (2 per unit)	26047
31	Beckett Oil Burner AF65XN (0.75, 0.85, 1.00 GPH) Wired for Fan and Limit Control	29592
	Beckett Oil Burner AF65XN (0.75, 0.85, 1.00 GPH) Wired for Fan Timer Control	240010428
	Burner Motor 1/7 HP 3450 RPM PSC	29689
	Beckett Clean-cut Oil Pump A2EA6520	29688
	Solid State Ignitor FRANCE 10SAY-01	29522
	Primary Combustion Control 7505B1500	240008816
	Air Tube Combination AF65XN	11986
	Flame Retention Head (F3)	1050003
31	Beckett Oil Burner AF65YB (1.10, 1.20 GPH) Wired for Fan and Limit Control	29594
	Beckett Oil Burner AF65YB (1.10, 1.20 GPH) Wired for Fan Timer Control	240010429
	Beckett Oil Burner NX70LFHS (1.10, 1.20 GPH) Wired for Fan and Limit Control	240010234
	Beckett Oil Burner NX70LFHS (1.10, 1.20 GPH) Wired for Fan Timer Control	240010430
	Burner Motor 1/7 HP 3450 RPM PSC	29689
	Beckett Clean-cut Oil Pump A2EA6520	29688
	Solid State Ignitor FRANCE 10SAY-01	29522
	Air Tube Combination AF65YB	20877
	Flame Retention Head (F6 for AF Burner)	1050004
31	Riello 40F3 Oil Burner (0.75, 0.85 GPH)	27343
32	Blower Assembly, Complete, Direct Drive, 1/2 HP	20643
	Blower Housing and Wheel, 100-10R DD	30624
	Blower Motor, 1/2 HP, 4-Speed	102000131
	Motor Mounting Band – TR5868	17811
	Motor Mount Arms – 10-10 DD Blower (3 per unit)	26251
	Motor Run Capacitor, 10 mfd @ 370 vac	27743
	Capacitor Strap	27761
	Blower Base Feet (2 per unit)	109005826
	Blower Base Feet Rubber Grommet (4 per unit)	26415
32	Blower Assembly, Complete, Belt Drive 1/3 HP	6033C6
	Blower Housing and Wheel, 100-10R BD	30625
	Blower Motor 1/3 HP SS	10200153
	Motor Pulley 3 1/4 X 1/2 Adjustable	2240001
	Blower Pulley 7 X 3/4	2240008
	Fan Belt 4L420	2240021
	Blower Base Feet (2 per unit)	109005826
	Blower Base Feet Rubber Grommet (4 per unit)	26415

* = Not Shown

PARTS LISTING

PARTS LISTING: CHIMNEY VENT MODELS BFL-(2,RF2) conti.

Ref. No.	Description	Part No.
32	Blower Assembly, Complete, Belt Drive 1/2 HP	6033C7
	Blower Housing and Wheel, 100-10R BD	30625
	Blower Motor ½ HP SS	102000154
	Motor Pulley 3 1/4 X 1/2 Adjustable	2240001
	Blower Pulley 6 X 3/4	2240006
	Fan Belt 4L410	2240020
	Blower Base Feet (2 per unit)	109005826
	Blower Base Feet Rubber Grommet (4 per unit)	26415
33	Flue Pipe Connector	28306
*	Vent Elbow 6" Short Radius	29476
*	Blocked Vent Safety Switch	30686
*	Blocked Vent Safety Switch - Replacement Switch Only	30660
*	Vent Elbow for Blocked Vent Safety Switch	30683

PARTS LISTING: CHIMNEY VENT MODELS BFL-T2

Ref. No.	Description	Part No.
All parts are the same as listed on the previous pages for Model BFL-2 except where noted below.		
4	Blower Division Panel Assembly	29114
24	Wire Harness Blower Direct Drive	27275
25	Wire Harness Fan & Limit	26838
26	Fan Centre Assembly	26857
	Replacement Relay R8228B1012B	26854
	Fuse ABC 15 Amp Slow Blow	2200096
	Fuse Holder HKP-HH BCL	27089
32	Blower Assembly, Complete, Direct Drive, 1 HP	26812
	Blower Housing and Wheel, 120-11T	240006678
	Blower Motor, 1 hp 3 Speed	102000157
	Motor Mounting Band – TR5868	17811
	Motor Mount Arms – TR7624B (3 per unit)	240006535
	Motor Run Capacitor, 20 mfd @ 370 vac	27745
	Capacitor Strap	27761
	Blower Base Feet LH	26013
	Blower Base Feet RH	26012
	Terminal Block #EE8-201	26833
	Blower Base Feet Rubber Grommet (4 required)	26415

* = Not Shown

PARTS LISTING

PARTS LISTING: DIRECT VENT MODELS BFL-B2U2

Ref. No.		Part No.
All parts are the same as listed on the previous pages for Model BFL-2 except where noted below.		
10	Heat Exchanger Assembly for Beckett AFII Burner	550001634
13	Replacement Combustion Chamber 27000B for Beckett AFII Burner	27000WP
18	Pouch Gasket (Second gasket required for Direct Vent)	2080175
31	Beckett Oil Burner AFII 150 Wired for Fan and Limit Control	30743
	Beckett Oil Burner AFII 150 Wired for Fan Timer Control	240010452
*	Burner Motor 1/7 HP 3450 RPM PSC	28907
	Beckett Clean-cut Oil Pump A2EA6520	29688
	Solid State Ignitor FRANCE 10SAY-04	28558
	Primary Combustion Control 7505P1530	
	Air Tube Combination FBX80HGXS	28561
	Flame Retention Head (FB3)	28533
33	Flue Connector Assembly 6" to 4" 90° Elbow	240008224
*	Appliance Adaptor 4" Breech to 4" Vent	240006903
*	Pressure Switch -0.33" WC	30734
*	10 Second Bypass Timer GPS00C9X10	30699
*	Combustion Air Intake Collar 4" for AFII Burner	109005950
*	Wire Harness Fan Timer Control (Direct Vent)	30745

* = Not Shown



HOMEOWNER'S REFERENCE TABLE

Model No.	
Serial No.	
Date Installed	
Contractor	
Contact	
Address	
Postal Code	
Telephone No.	
After Hours No.	

Fuel Supplier

Fuel Oil Supplier	
Contact	
Telephone No.	
After Hours No.	