

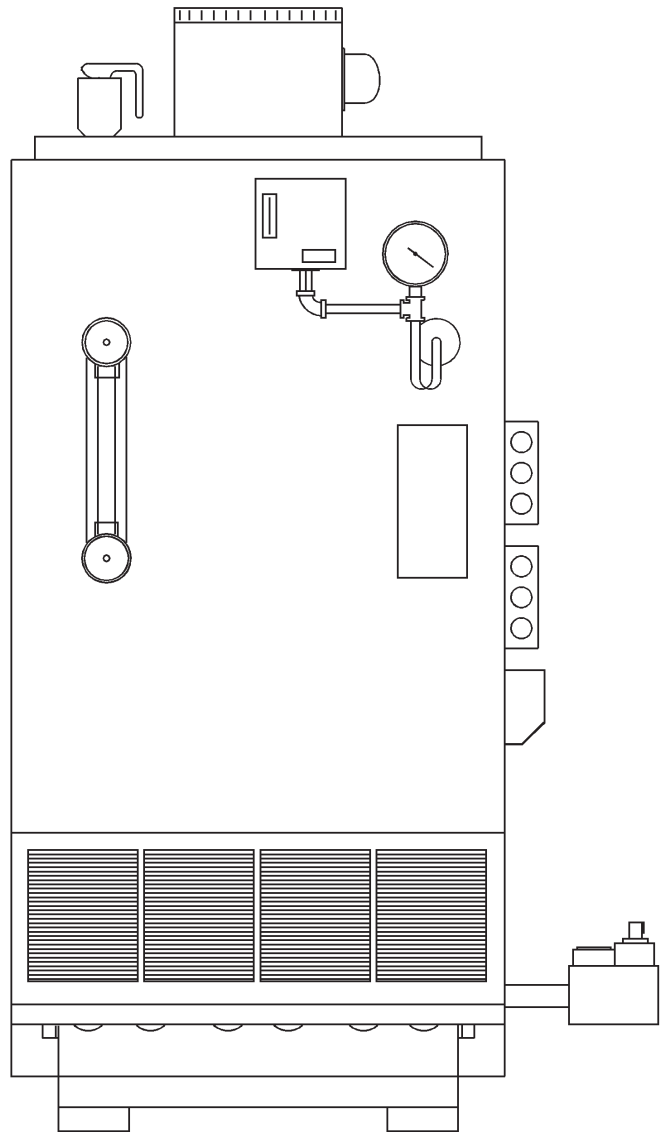

CEG-C GAS FIRED BOILERS FOR STEAM HEATING INSTALLATION, OPERATION & MAINTENANCE MANUAL



COLUMBIA COMPANY
Main offices and factory
Pottstown, PA



TABLE OF CONTENTS

Safety Symbols 3
Installation Procedure 4
Ventilation & Combustion Air 5
Connecting Supply And Return Piping 6
Vent Installation 8
Vent System Modification..... 9
Vent Damper Installation10
Connecting Gas Service11
Electrical Wiring12
Thermostat Installation12
Wiring Diagrams And Component Coding13
Lighting Instructions16
Normal Sequence Of Operation.....18
Connecting Supply And Return Piping, Water Chilled Medium19
General Instructions20
Cleaning Boiler Flue-Ways.....21
Maintaining Your Boiler.....22
CEG-C Replacement Parts24

KEEP THIS MANUAL NEAR BOILER
RETAIN FOR FUTURE REFERENCE

SERIES CEG-C
CAST IRON
GAS FIRED BOILERS

INSTALLATION MANUAL AND
OPERATING INSTRUCTIONS



C.S.A. Certified
for Natural gas
or Propane



Tested for 100 psi.
ASME Working
Pressure

SAFETY SYMBOLS

The following defined symbols are used throughout this manual to notify the reader of potential hazards of varying risk levels.

DANGER



Indicates a hazardous situation which, if not avoided, WILL result in death or serious injury.

WARNING



Indicates a hazardous situation which, if not avoided, could result in death or serious injury.

CAUTION



Indicates a hazardous situation which, if not avoided, may result in minor or moderate injury.

NOTICE

Indicates information which should be followed to ensure proper installation and operation.

READ ALL INSTRUCTIONS BEFORE INSTALLING.

WARNING

Keep boiler area clear and free from combustible materials, gasoline and other flammable vapors and liquids.

DO NOT obstruct air openings to the boiler room.

Modification, substitution or elimination of factory equipped, supplied or specified components may result in property damage, personal injury or the loss of life.

To the owner: Installation and service of this boiler must be performed by a qualified installer.

To the installer: Leave all instructions with the boiler for future reference.

When this product is installed in the Commonwealth of Massachusetts the installation must be performed by a Licensed Plumber or Licensed Gas Fitter.

WARNING

All installations of boilers and venting should be done only by a qualified expert and in accordance with the appropriate Utica Boilers Installation, Operation and Maintenance manual. Installing or venting a boiler or any other gas appliance with improper methods or materials may result in serious injury or death due to fire or to asphyxiation from poisonous gases such as carbon monoxide which is odorless and invisible.

INSTALLATION PROCEDURE

WARNING



Improper installation, adjustment, alteration, service or maintenance can cause injury.

- The installation must conform to the requirements of the authority having jurisdiction or, in absence of such requirements, to the latest revision of the National Fuel Gas Code, ANSI Z223.1/NFPA 54. Reference should also be made to local gas utility regulations and other codes in effect in the area that the installation is to be made.
- Where required by the authority having jurisdiction, the installation must conform to the Standard for Controls and Safety Devices For Automatically Fired Boilers, ANSI/ASME CSD-1.
- This boiler is classified as a Category I appliance and the vent installation shall be in accordance with "Venting of Equipment" of the National Fuel Gas Code noted above or applicable provisions of the local building codes. See Vent Installation on page 8.
- This boiler meets safe lighting and other preference criteria with the gas manifold and control assembly provided on the boiler per the latest revision of ANSI Z21.13.
- This boiler shall be installed such that the gas ignition system components are protected from water (dripping, spraying, rain, etc.) during appliance operation and service, (circulator replacement, condensate trap, control replacement, etc.).
- LOCATE BOILER on level, solid base as near chimney as possible and centrally located with respect to the heat distribution system as practical.
- ALLOW 24 inches at the front and right side for servicing and cleaning.
- When installing in a utility room, the door should be wide enough to allow the largest boiler part to enter, or to permit replacement of another appliance such as a water heater.

- FOR INSTALLATION ON NONCOMBUSTIBLE FLOORS ONLY. *The boiler must not be installed on carpeting. Minimum clearances to combustible construction are:

Minimum Clearances to Combustible Construction	
Top	24 inch
Front	Alcove
Flue collector	6 inch
Rear	18 inch
Sides	6 inch

Note: Greater clearances for access should supersede fire protection clearance.

WARNING



Air openings to combustion area must not be obstructed. Following instructions below, adequate combustion air can be maintained.

Provide combustion air and ventilation air in accordance with the section "Air for Combustion and Ventilation," of the National Fuel Gas Code, ANSI Z223.1 / NFPA 54, or applicable provisions of local building codes.

Provide make-up air where exhaust fans, clothes dryers, and kitchen ventilation equipment interfere with proper operation.

National Fuel Gas Code recognizes several methods of obtaining adequate ventilation and combustion air. Requirements of the authority having jurisdiction may override these methods.

- Engineered Installations. Must be approved by authority having jurisdiction.
- Mechanical Air Supply. Provide minimum of 0.35 cfm per Mbh for all appliances located within space. Additional requirements where exhaust fans installed. Interlock each appliance to mechanical air supply system to prevent main burner operation when mechanical air supply system not operating.
- All Indoor Air. Calculate minimum volume for all appliances in space. Use a different method if minimum volume not available.
 - A. Standard Method. Cannot be used if known air infiltration rate is 0.40 air changes per hour. See Table 1 for space with boiler only. Use equation for multiple appliances.

$$\text{Volume} \geq 50 \text{ ft}^3 \times \text{Total Input [Mbh]}$$

- B. Known Air Infiltration Rate. See Table 1 for space with boiler only. Use equation for multiple appliances. Do not use an air infiltration rate (ACH) greater than 0.60.

$$\text{Volume} \geq 21 \text{ ft}^3/\text{ACH} \times \text{Total Input [Mbh]}$$

- C. Refer to National Fuel Gas Code for opening requirements between connected indoor spaces.
- All Outdoor Air. Provide permanent opening(s) communicating directly or by ducts with outdoors.
 - A. Two Permanent Opening Method. Provide opening commencing within 12 inches of top and second opening commencing within 12 inches of bottom of enclosure.
 - Direct communication with outdoors or communicating through vertical ducts. Provide minimum free area of 1 in² per 4 Mbh of total input rating of all appliances in enclosure.
 - Communicating through horizontal ducts. Provide minimum free area of 1 in² per 2 Mbh of total input rating of all appliances in enclosure.
 - B. One Permanent Opening Method. Provide opening commencing within 12 inches of top of enclosure. Provide minimum clearance of 1 inch on sides/back and 6 inches on front of boiler (does not supersede clearance to combustible materials).
 - C. Refer to National Fuel Gas Code for additional requirements for louvers, grilles, screens and air ducts.
- Combination Indoor and Outdoor Air. Refer to National Fuel Gas Code for application information.

Table 1 - Minimum Room Volume, Indoor Air Only*

Input Mbh	Standard Method	Known Air Infiltration Rate Method (Air Changes Per Hour)					
		0.1	.02	.03	.04	.05	.06
112.5	5625	23625	11813	7875	5906	4725	3938
150	7500	31500	15750	10500	7875	6300	5250
187	9350	39270	19635	13090	9818	7854	6545
255	11250	47250	23625	15750	11813	9450	7875
262.5	13125	55125	27563	18375	13781	11025	9188
300	15000	63000	31500	21000	15750	12600	10500

* Table values based on boiler only. Add volume for any additional appliances.

CONNECTING SUPPLY AND RETURN PIPING

Figure 2 - SUGGESTED PIPING FOR A MODULAR STEAM BOILERS - Pumped Returns

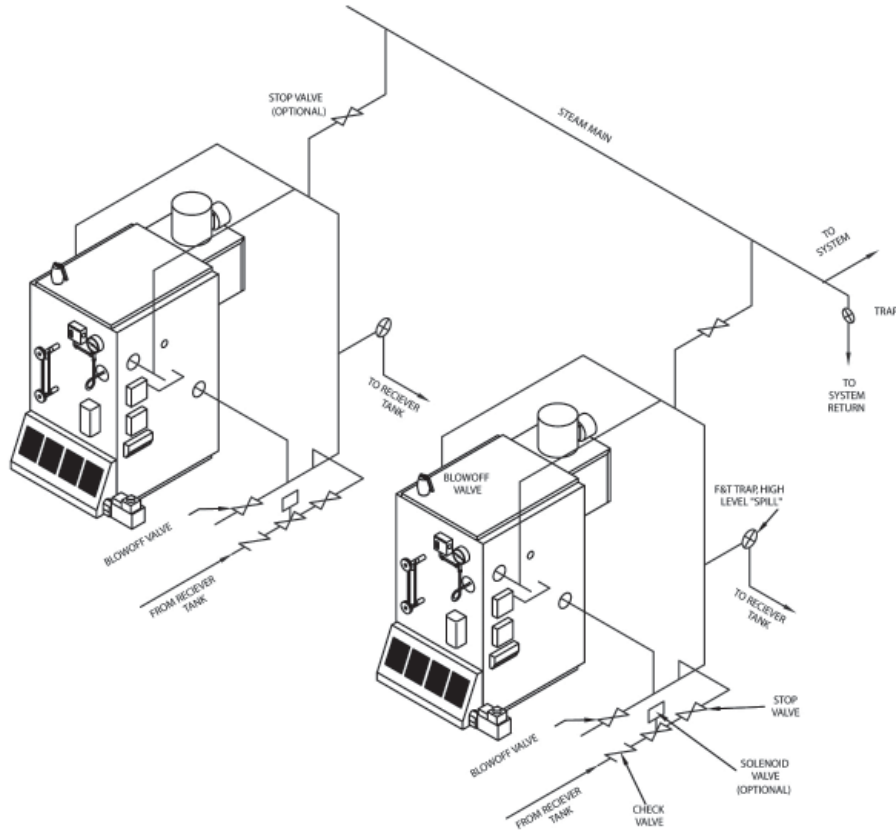
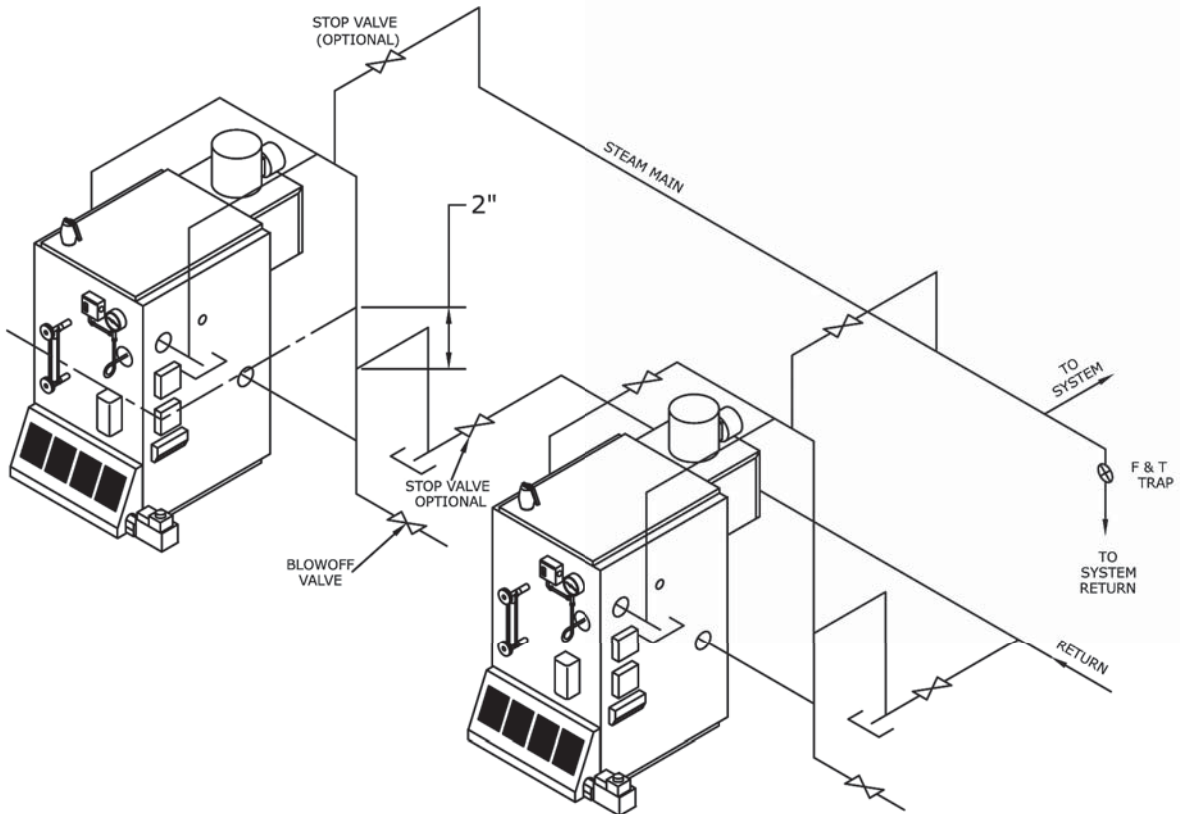

Figure 3 -SUGGESTED PIPING FOR A MODULAR STEAM BOILERS - Gravity Returns



VENT INSTALLATION

WARNING



Boiler shall not be connected to any portion of mechanical draft system operating under positive pressure.

- The vent pipe must slope upward from the boiler not less than 1/4 inch for every 1 foot to the vent terminal.
- Horizontal portions of the venting system shall be supported rigidly every 5 feet and at elbows. No portion of the vent pipe should have dips or sags.
- This boiler series is classified as a Category I appliance and the vent installation shall be in accordance with "Venting of Equipment" of the National Fuel Gas Code, ANSI Z223./NFPA, or applicable provisions of the local building codes.
- Inspect chimney to make certain it is constructed according to National Board of Fire Underwriters.
- Attach draft hood to flue collector at rear of boiler, (See figure 4, below), with sheet metal screw(s) through hole(s) provided. The vent or vent collector shall be Type B or metal pipe having resistance to heat and corrosion not less than that of galvanized sheet steel or aluminum not less than 0.016 inch thick (No. 28 GA). Do not modify draft hood.
- Connect flue pipe same as draft hood to chimney. Bolt or screw joints together to avoid sag. Flue pipe should not extend beyond inside wall of chimney. Do not install manual damper in flue pipe or reduce size of flue outlet except as provided by the latest revision of ANSI Z223.1. Protect combustible ceiling and walls near flue pipe with fireproof insulation. Where two or more appliances vent into a common flue, the area of the common flue must be at least equal to the area of the largest flue plus 50 percent of the areas of each additional flue.

WARNING



Installations of boilers and venting should be done only by a qualified expert and in accordance with the appropriate Utica Boiler's Installation, Operation and Maintenance Manual. Installing or venting a boiler or any other gas appliance with improper methods or materials may result in serious injury or death due to fire or to asphyxiation from poisonous gases such as carbon monoxide which is odorless and invisible.

Figure 4 Blocked Vent Safety Switch

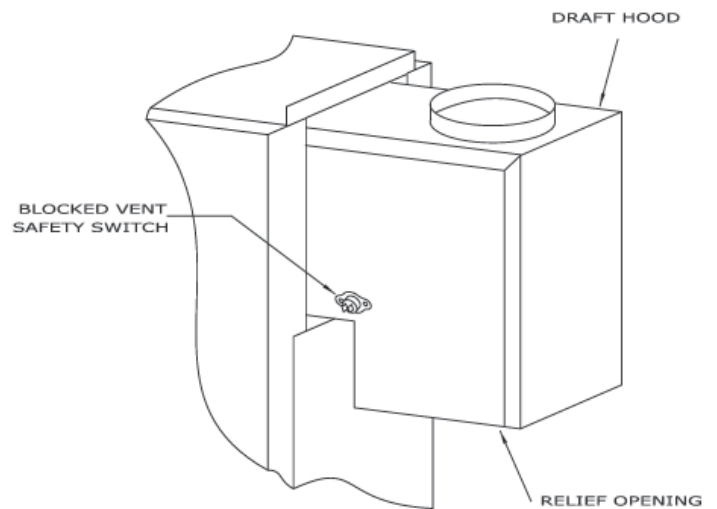

VENT SYSTEM MODIFICATION

When an existing boiler is removed from a common venting system, the common venting system is likely to be too large for the proper venting of the appliances remained connected to it. If this situation occurs, the following test procedure must be followed:

At the time of removal of an existing boiler, the following steps shall be followed with each appliance remaining connected to the common venting system placed in operation, while the other appliances remaining connected to the common venting system are not in operation.

- Seal any unused openings in the common venting system.
- Visually inspect the venting system for proper size and horizontal pitch and determine there is no blockage or restriction, leakage, corrosion and other deficiencies which could cause an unsafe condition.
- Insofar as is practical, close all building doors and windows and all doors between the space in which the appliances remaining connected to the common venting system are located and other spaces in the building. Turn on clothes dryers and any appliance not connected to the common venting system. Turn on any exhaust fans, such as range hoods and bathroom exhausts, so they will operate at maximum speed. Do not operate a summer exhaust fan. Close fireplace damper.
- Place in operation the appliance being inspected. Follow the lighting instructions. Adjust thermostat so appliance will operate continuously.
- Test for spillage at the draft hood relief opening after 5 minutes of main burner operation. Use the flame of a match or candle, or smoke from a cigarette, cigar or pipe.
- After it has been determined that each appliance remaining connected to the common venting system properly vents when tested as outlined above, return doors, windows, exhaust fans, fireplace dampers, and any other gas burning appliance to their previous condition of use.
- Any improper operation of the common venting system should be corrected so the installation conforms with the latest revision of the National Fuel Gas Code, ANSI Z223.1/NFPA 54. When re-sizing any portion of the common venting system, the common venting system should be re-sized to approach the minimum size as determined using the appropriate tables in Chapter 13 of the National Gas Fuel Code, ANSI Z223.1/NFPA 54.

VENT DAMPER INSTALLATION

Vent Damper Installation

Note: Refer To Figure 5 Below For Steps 1-7

1. Place Vent Damper on or as close to vent outlet of boiler as possible. Do not modify vent damper.
2. Remove Locknut from connector at the free end of the Damper wire harness.
3. Feed Damper connector and Damper wire harness through bracket hole on Damper Motor frame.
4. Replace and tighten locknut onto Damper wire harness connector.
5. Plug Damper connector into socket on Damper Motor frame.
6. Ensure that only the boiler is serviced by the Vent Damper. See figure 6.
7. Clearance of not less than 6 inches between Vent Damper and combustible construction must be maintained. Additional clearance should be allowed for service of the Vent Damper.
8. Vent Damper must be in open position when appliance main burners are operating.
9. The Vent Damper position indicator must be in a visible location following installation.
10. The thermostats heat anticipator must be adjusted to match the total current draw of all controls associated with the boiler during a heating cycle.
11. The Vent Damper wire harness may be removed and installed in flexible metal conduit if local codes or jurisdiction requires. If this is necessary, the flexible metal conduit must be mounted to a J-box and all appropriate connections must be made to this J-box.

Figure 5 - Standard Vent Damper Installation

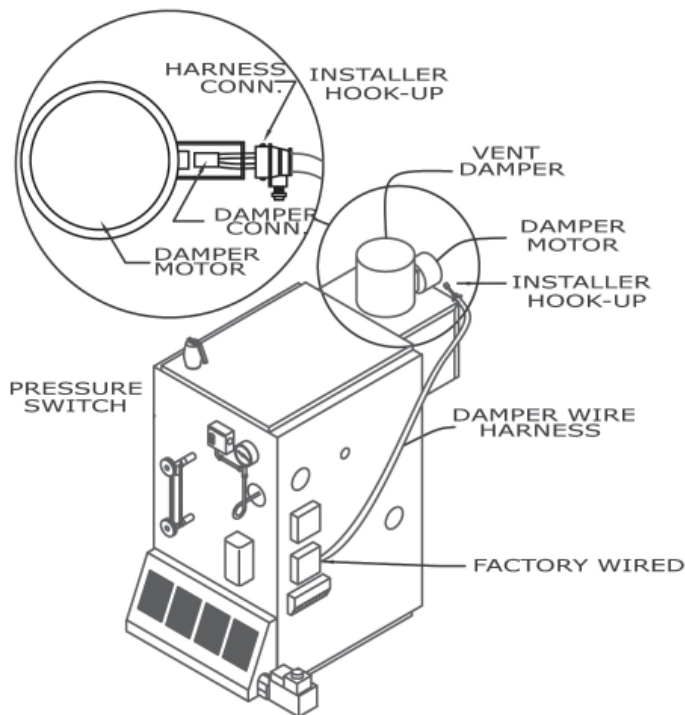
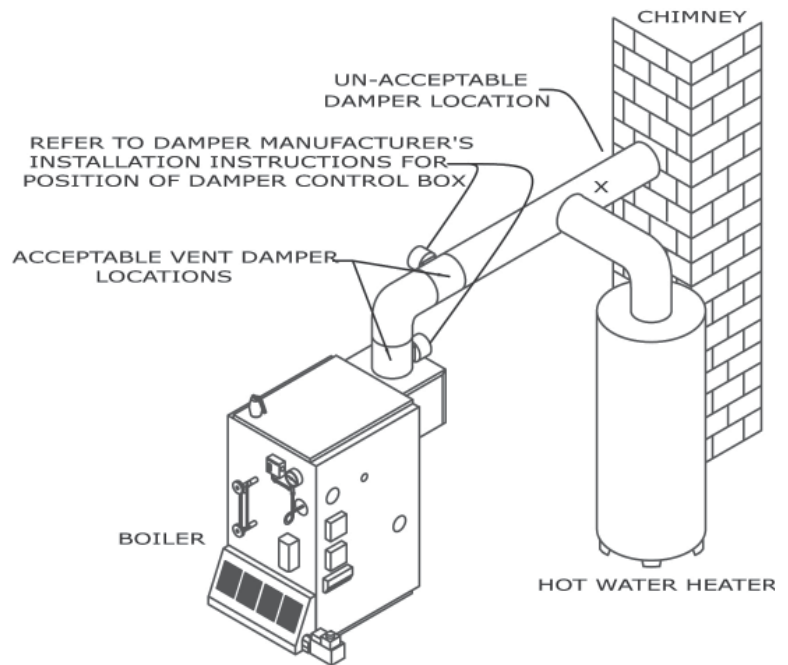
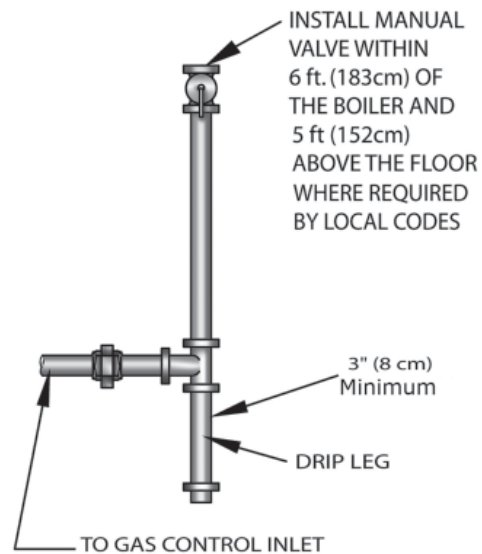

Figure 6 - Alternate Vent Damper Installation



- Connect gas service meter to control assembly in accordance with the latest revision of the National Fuel Gas Code ANSI Z223.1/NFPA 54 and local codes or utility.
- Ground joint union should be installed for easy removal of gas control for servicing.
- Drip or trap must be installed at the bottom of a vertical section of piping at the inlet to the gas valve.
- Pipe compound resistant to the action of liquefied petroleum gases must be used on all threaded pipe connections.
- Check with the local utility for location of manual shutoff valve if required. See figure 7.
- Gas line should be of adequate size to prevent undue pressure drop and never smaller than the pipe size of the main gas control valve.
- Boiler and its gas connection must be leak tested before placing the boiler in operation. To check for leaks in gas piping, use a soap and water solution or other approved method.

Figure 7 Gas Drip Let

**WARNING**

Do not use an open flame.

- Boiler and its individual shutoff valve must be disconnected from the gas supply piping system during any pressure testing of that system at test pressures in excess of 1/2 psi (3.5 kPa). The boiler must be isolated from the gas supply piping system by closing its individual manual shutoff valve during any pressure testing of the gas supply piping system at test pressures equal to or less than 1/2 psig (3.5 kPa).

SEE PAGE 14 FOR WIRING DIAGRAMS AND COMPONENT CODING

Electrical wiring must conform with the latest revision of the National Electrical Code, ANSI/NFPA No. 70 and/or local authority having jurisdiction.

WARNING

Boiler, when installed, must be electrically bonded to ground in accordance with the requirements of the authority having jurisdiction or, in the absence of such requirements, with the National Electrical Code, ANSI/NFPA 70.

Install a fused disconnect switch between boiler and meter at a convenient location.

THERMOSTAT INSTALLATION

- Thermostat should be installed on an inside wall at least two feet from a non-insulated or outside wall, approximately four feet above the floor.
- NEVER install a thermostat on an outside wall.
- Do not install a thermostat where it will be affected by:
 - A. Drafts
 - B. Hot or cold pipes
 - C. Sun light
 - D. Lighting fixtures
 - E. Television
 - F. Fireplace or chimneys
- Check thermostat operation by raising and lowering thermostat as required to start and stop the burners.
- Instructions for the final adjustment of the thermostat are packaged with the thermostat (adjusting heating anticipator, calibration, etc.).

CAUTION

! Label all wires prior to disconnection when servicing controls. Wiring errors can cause improper and dangerous operation. Verify proper operation after servicing.

STEAM CONTROL AND INTERMITTENT IGNITION WIRING FOR PEG SERIES BOILER

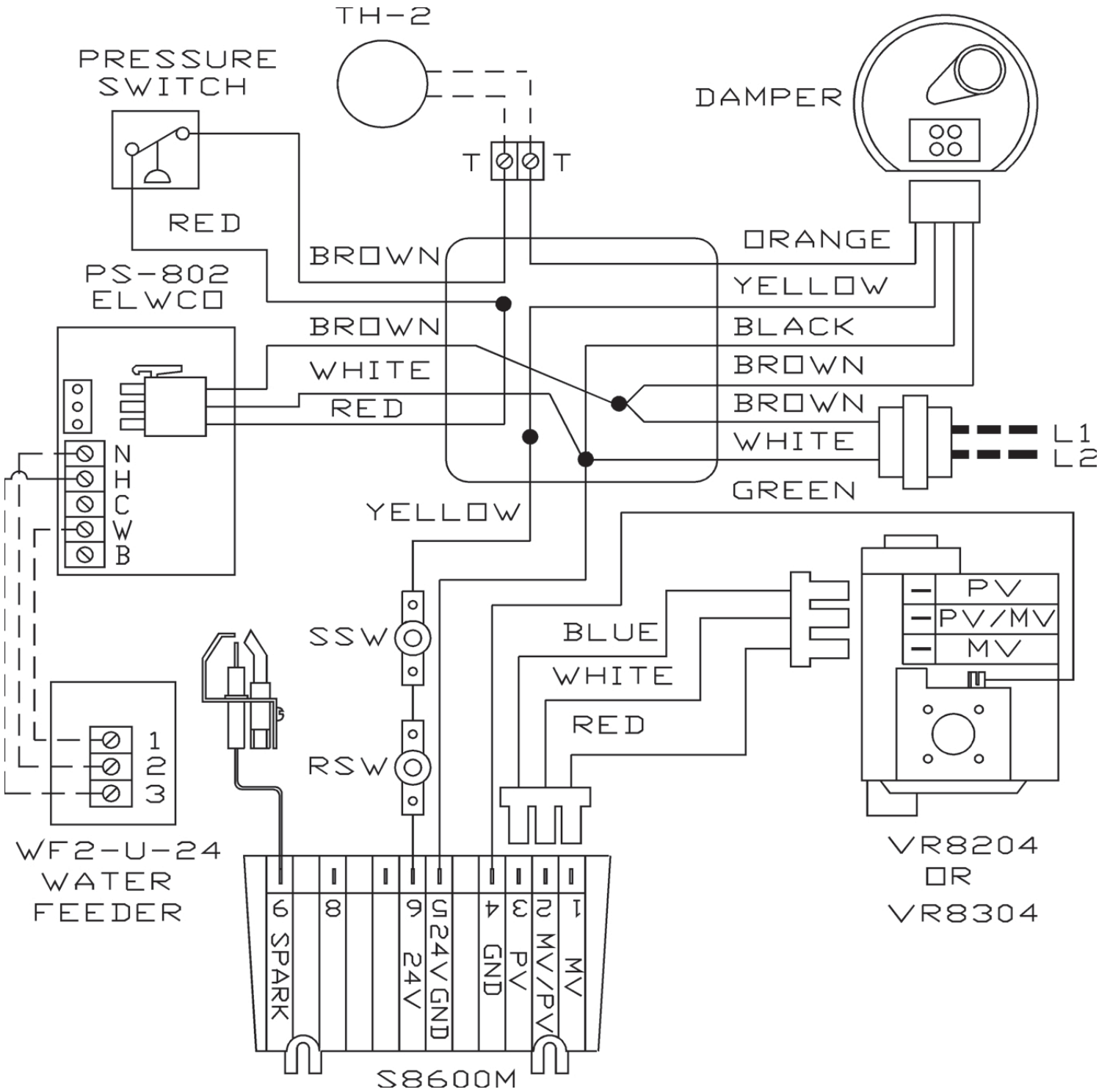

24 VOLT GAS CONTROL WITH ELECTRONIC LOW WATER CUT-OFF

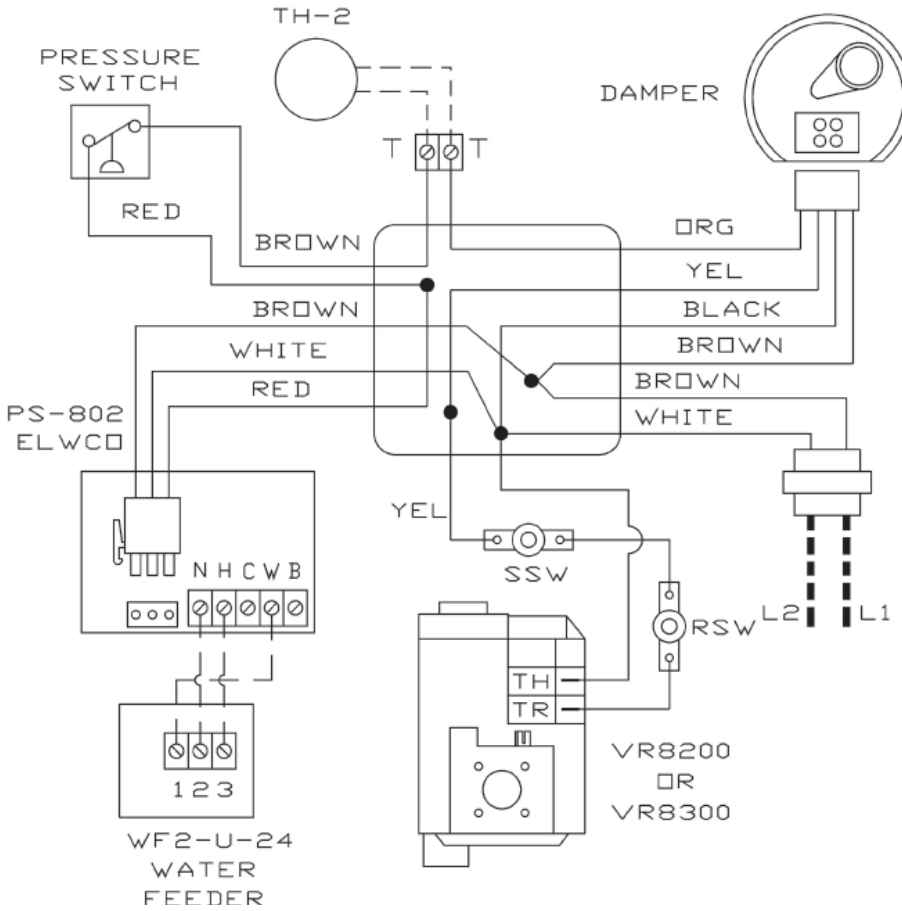

COMPONENT CODE

TH-1	THERMOSTAT (MILLIVOLT)
TH-2	THERMOSTAT (24 VOLT)
TH-3	THERMOSTAT (LINE VOLTAGE)
TR-1	TRANSFORMER (120V/24V 40VA)
TR-2	TRANSFORMER (120V/24V 50VA)
MGV	MILLIVOLT GAS VALVE
LGV	24 VOLT GAS VALVE
LGV-1	24 VOLT GAS VALVE
PS	PRESSURE SWITCH
MR-PS	MANUAL RESET PRESSURE SW.
SD	STACK DAMPER CONTROL TERMINAL

1 K	RELAY COIL
1 K1	RELAY CONTACTS
1 K2	RELAY CONTACTS
LS	LIMIT SWITCH
MS	MANUAL SWITCH
CIR	CIRCULATOR
ECO	ENERGY CUT-OFF
LWCO	LOW WATER CUT-OFF
EFW	ELECTRIC WATER FEEDER
PG	POWER GENERATOR
PSC	PILOT SAFETY COIL WIRE CONNECTION

NOT ALL COMPONENTS LISTED ARE USED IN ALL CONTROL SYSTEMS

————	WIRING
————	LINE VOLTAGE BY FACTORY
---	LOW VOLTAGE BY FACTORY
- - -	LINE VOLTAGE BY INSTALLER
- - -	LOW VOLTAGE BY INSTALLER

NOTES:

1. Switches are shown in position taken during the heating cycle.
2. If any of the original wiring supplied with the boiler is replaced, it must be replaced with like wire, size, and type of insulation or equivalent

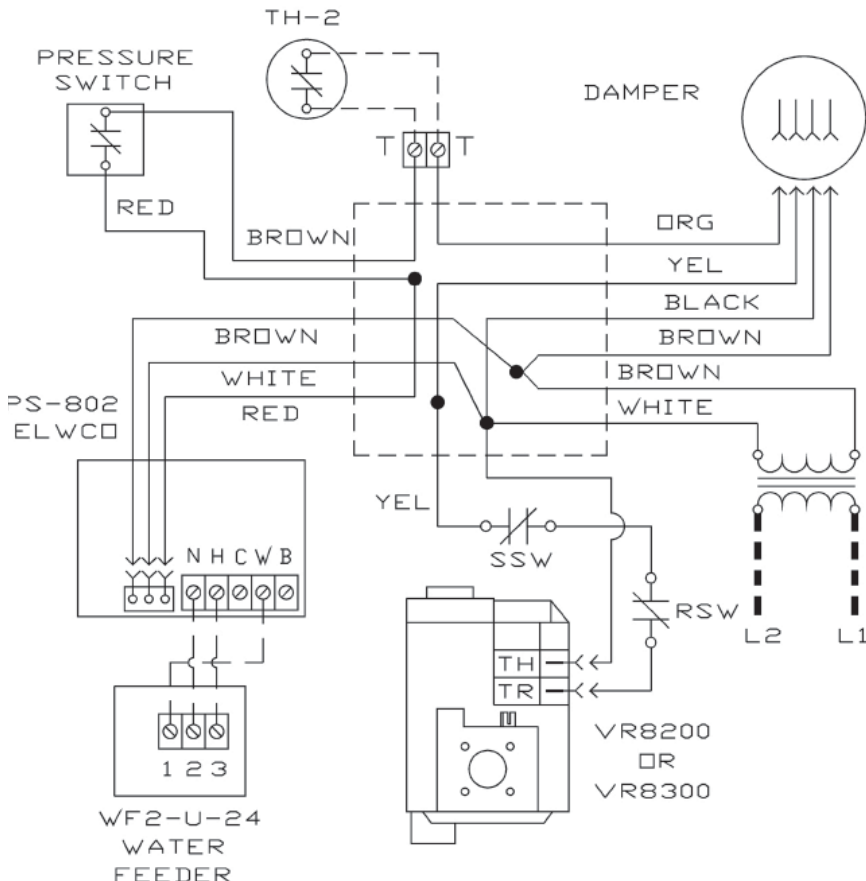

LIGHTING INSTRUCTIONS

WARNING



If you do not follow these instructions exactly, a fire or explosion may result causing personal injury or loss of life.

Before any procedures are attempted on this appliance, it is necessary to determine if the ignition system is intermittent or continuous pilot system. If you are uncertain, contact the manufacturer before proceeding.

CAUTION



Before operating, make certain steam boiler is full of water to water line and system is vented of air. See the operating lighting instructions.

LIGHTING PROCEDURE FOR BOILER WITH INTERMITTENT PILOT SYSTEM.

FOR YOUR SAFETY READ BEFORE OPERATING.

- This appliance is equipped with an ignition system which automatically lights the pilot. Do not try to light the pilot by hand.
- Before operating smell all around the appliance area for gas. Be sure to smell next to the floor because some gas is heavier than air and will settle on the floor.

CAUTION

WHAT TO DO IF YOU SMELL GAS

Do not try to light any appliance.

Do not touch any electrical switch; do not use any phone in your building.

Immediately call your gas supplier from a neighbor's phone. Follow gas supplier's instructions.

If you cannot reach your gas supplier, call the fire department.

- Use only your hand to push in or turn gas control knob. Never use tools. If the knob will not push in or turn by hand, don't try to repair it, call a qualified service technician. Force or attempted repair may result in a fire or explosion.

- Do not use this appliance if any part has been under water. Immediately call a qualified service technician to inspect the appliance and to replace any part of the control system and gas control which has been under water.

OPERATING INSTRUCTIONS FOR INTERMITTENT PILOT SYSTEMS



1. **STOP!** Read all safety information starting on this page.
2. Set thermostat to lowest setting.
3. Turn off all electric power to the appliance.
4. This appliance is equipped with an ignition device which automatically lights the pilot. DO NOT try to light the pilot by hand.
5. Remove access panel (if present)
6. Push in gas control knob slightly and turn clockwise  to "OFF."
7. Wait five (5) minutes to clear out any gas. If you then smell gas, STOP, Follow "B" in the safety information "What To Do If You Smell Gas". If you don't smell gas, go to the next step.
8. Turn gas control knob counterclockwise  to "ON."
9. Replace control access panel (IF PRESENT).
10. Turn on all electric power to the appliance.
11. Set thermostat to desired setting.
12. If the appliance will not operate, follow the instructions "To Turn Off Gas To Appliance" and call a qualified service technician or your gas supplier.
13. Do not use this appliance if any part has been under water. Immediately call a qualified service technician to inspect the appliance and to replace any part of the control system and any gas control which has been under water.

Figure 8 - Intermittent Pilot Gas Valve



LIGHTING PROCEDURE FOR BOILER WITH CONTINUOUS PILOT SYSTEM.

FOR YOUR SAFETY READ BEFORE OPERATING.

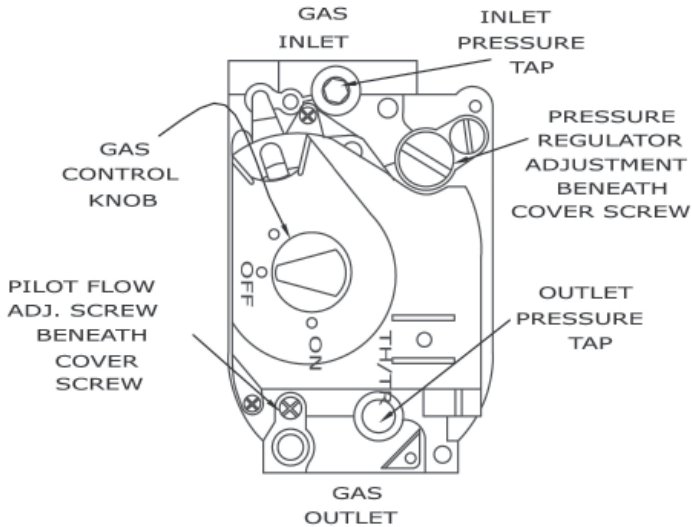
- Read Warning on page 16.
- This appliance is equipped with a pilot which must be lighted by hand. When lighting the pilot follow these instructions exactly.
- Before operating smell all around the appliance area for gas. Be sure to smell next to the floor because some gas is heavier than air and will settle on the floor. Follow Caution on page 16 for safety information for what do do if you smell gas.
- Use only your hand to push in or turn gas control knob or reset button. Never use tools. If knob or reset button will not push in or knob will not turn by hand, don't try to repair it. Call a qualified service technician. Force or attempted repair may result in fire or explosion. See figure 9.
- Do not use this appliance if any part has been underwater. Immediately call a qualified service technician to inspect the appliance and to replace any part of the control system and any gas control which has been under water.

LIGHTING INSTRUCTIONS FOR BOILER WITH CONTINUOUS PILOT SYSTEM.

1. **Stop!** Read the safety information starting on page 17.
2. Set thermostat to lowest setting.
3. Turn off all electric power to the appliance.
4. Remove manifold cover and burner door, (figures 10 & 12).

Figure 9 - Continuous Pilot Gas Valve

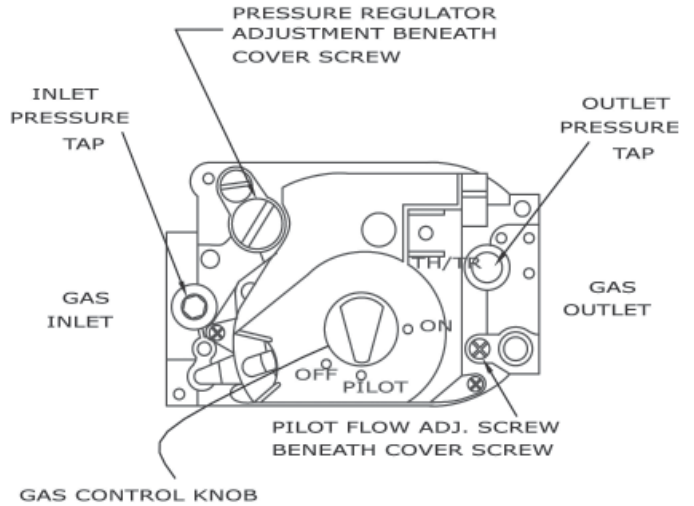

5. Turn gas control knob clockwise to "off" (See Note #1).
NOTE: Some gas control knobs cannot be turned from "pilot" to "off" unless knob is pushed in slightly. Do not force.
6. Wait (5) minutes to clear out any gas. If you smell gas, stop! Follow safety information "What to do if you smell gas," located on page 16 of this manual. If you don't smell gas, go to the next step.
7. Find pilot. Follow metal tube from gas control. Depending on the model of the boiler, pilot is mounted on the base or on one of the burner tubes.
8. Turn gas control knob counterclockwise to "pilot".
9. Push in gas control knob, or reset button if so equipped, all the way in and hold. Immediately Light the pilot with a match. Continue to hold the gas control knob or reset button for about one (1) minute after the pilot is lit. Release knob or button and it will pop back up. Pilot should remain lit. If it goes out, repeat steps 5 through 9.
 - If knob or button does not pop up when released, stop and immediately call your service technician or gas supplier.
 - If the pilot will not stay lit after several tries, turn the gas control knob clockwise to "off" (see note*) and call a service technician or gas supplier.
10. Replace burner door and manifold cover, (figures 10 & 12).
11. Turn gas control knob counterclockwise to "on".

LIGHTING INSTRUCTIONS

TO TURN OFF GAS TO APPLIANCE

1. Set thermostat to lowest setting.
2. Turn off all electric power to appliance if service is to be performed.
3. Remove access panel (if present).
4. Turn gas control knob clockwise  to "off".
NOTE: Some gas control knobs cannot be turned from "pilot" to "off" unless knob is pushed in slightly. Do not force. **Do not force.**

NORMAL SEQUENCE OF OPERATION

On a call for heat:

1. The thermostat will actuate completing the circuit between T and T.
2. The damper will then open thus closing the end switch completing the circuit, and ignition will begin.
3. In the event that the boiler steam pressure exceeds the pressure control setting, the pressure control will interrupt the circuit to the boiler ignition system. The power will remain off until the steam pressure drops below the pressure control setting.
4. In the event a low water condition occurs, an automatic low water cut-off device will interrupt the circuit to the ignition system until the low water condition is satisfied, (i.e., manually restore the water or utilize an electric water feeding device which will automatically restore boiler water to its normal operating level).
5. In the event the flow of combustion products through the boiler venting system becomes blocked, a blocked vent safety switch will shut the main burner gas off (See figure 13 below).
6. In the event the flow of combustion products through the flue-ways becomes blocked a flame rollout switch will shut the main burner gas off. See figure 10.

Figure 10 - Roll-Out Safety Switch

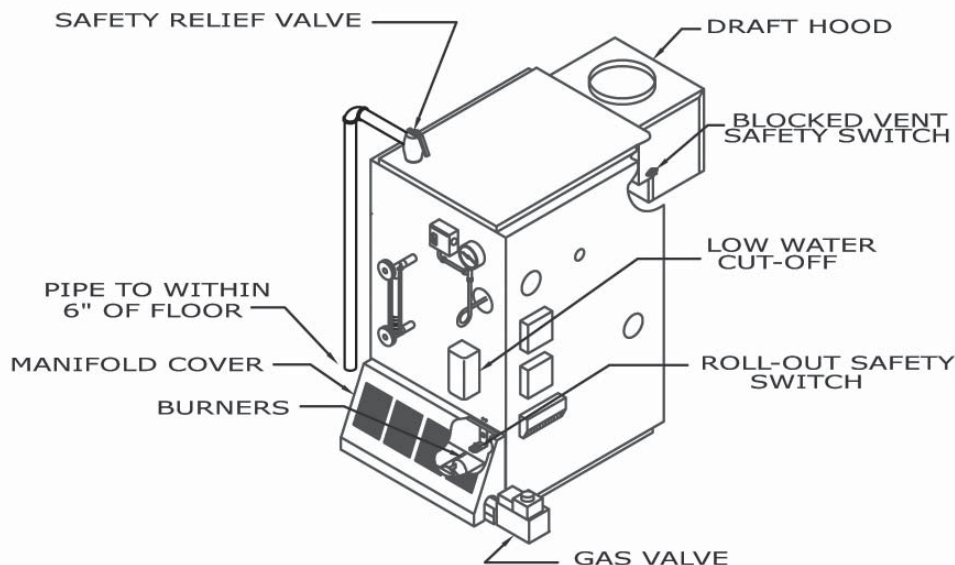

CONNECTING SUPPLY AND RETURN PIPING, WATER CHILLED MEDIUM

1. Boiler, when used in connection with a refrigeration system, must be installed so the chilled medium is piped in parallel with the boiler with appropriate valves to prevent the chilled medium from entering the boiler. See figure 11.
2. When the boiler is connected to heating coils located in air handling units where they may be exposed to refrigerated air circulation, the boiler piping system MUST be supplied with flow control valves or other automatic means to prevent gravity circulation of the boiler water during the cooling cycle.
3. A hot water boiler installed above radiation level, or as required by Authority having jurisdiction, must be provided with a low water cutoff device either as a part of the boiler or at the time of boiler installation.
4. Suggested piping for steam heating system can be seen in figure 1 on page 6. Actual piping may vary based on system design and local conditions.

Figure 11 - Boiler with Refrigeration System

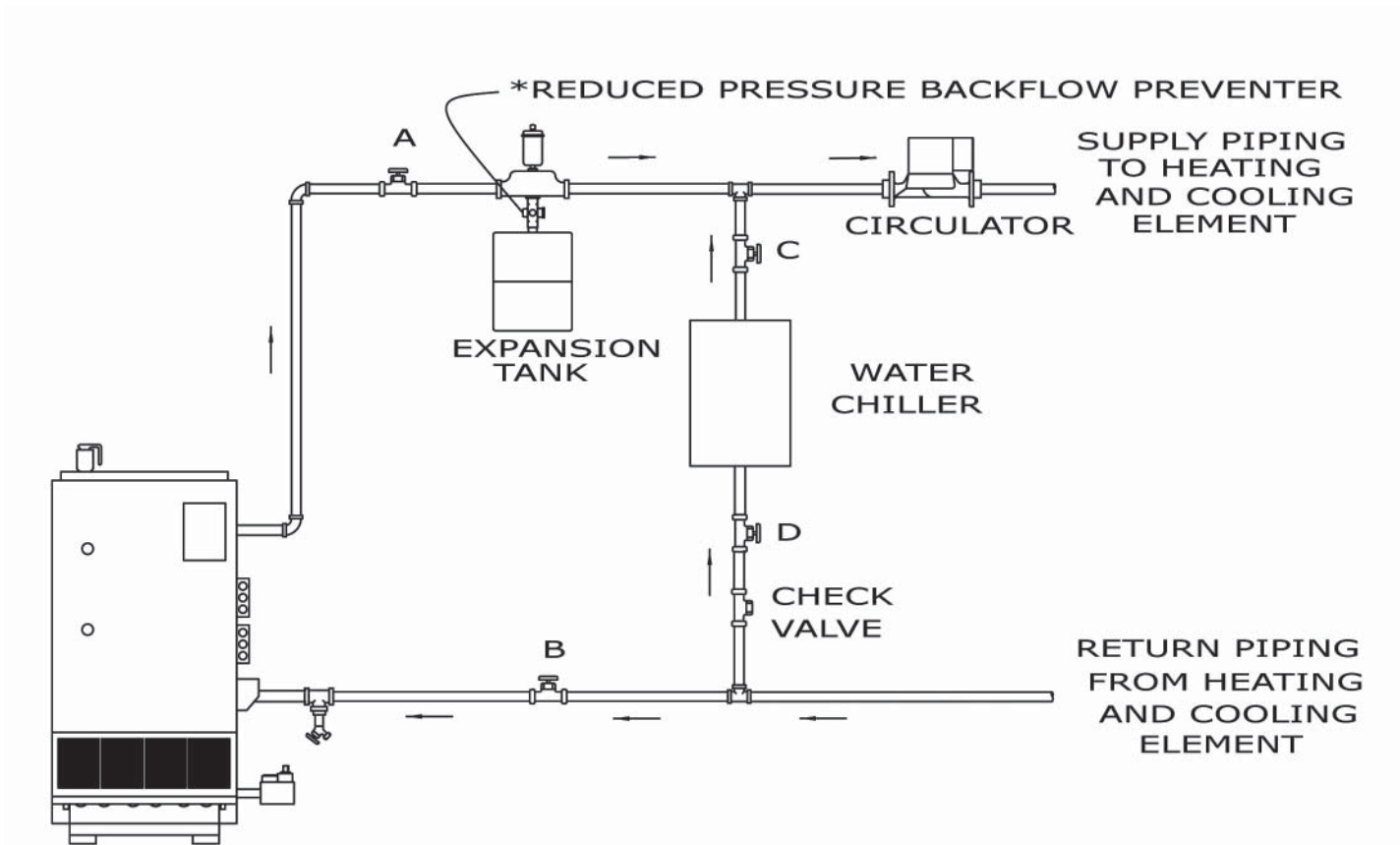

* Reduced pressure back-flow preventer must be present under provisions required by the Environmental Protection Agency, (EPA).

GENERAL INSTRUCTIONS

- Before seasonal start up it is advisable to have a competent service agency check the boiler for soot and scale in the flues, clean the burners, and check the gas input rate to maintain high operating efficiency.
- On steam boilers make certain the boiler is filled to the water line as indicated in figure 12. The gauge cocks should be normally open. To remove dirt from the gauge glass the petcock may be opened to flush out the glass.



WARNING

Discharge will be boiling hot water.

- The radiator valves on a one-pipe steam system must be either wide open or tightly shut. Do not attempt to regulate room temperature by partially closing the radiator valve.
- Air vents on steam radiators and the supply main release air from the system. If radiators do not heat satisfactorily, make sure the air vents are clean and operational.
- The lever of the safety valve, shown in figure 12, on the boiler should be operated periodically to make sure that it is functioning properly.



WARNING

Discharge will be boiling hot water and steam.

- The safety valve should open before the steam pressure exceeds the 15 lb. reading on the gauge. If this pressure is exceeded and the safety valve does not open, it must be replaced. If the safety valve leaks steam when the boiler is operating at normal pressures, it should be immediately replaced. Corrosion can build up rapidly at the valve seat and prevent its functioning as a safety device.

- During the heating season the drain valve, on the bottom rear of the boiler, should be opened once a month to flush out the boiler so the device will be free to function properly. Use a pail to catch the discharge.



WARNING

Discharge will be boiling hot water.

- If the water in a steam boiler appears to be dirty or oily, or the water level in the gauge glass fluctuates considerably, the boiler should be cleaned and skimmed (See page 21 for instructions). A competent service person will use approved cleaning compounds and properly clean and flush out the boiler. He/she should also clean or replace air vents and traps, clean flue passages and check for proper operation of all controls and safety devices.
- Venting system should be inspected at the start of each heating season. Check the vent pipe from the boiler to the chimney for signs of deterioration by rust or sagging joints. Repair if necessary. Remove the vent pipe at the base of the chimney or flue and, using a mirror, check for obstruction.
- Boiler flue gas passageways may be inspected by a light and mirror. Remove the burner access door, (figure 12). Place a trouble lamp in the flue collector through the draft-hood relief opening. With the mirror positioned above the burners, the flue gas passageways can be checked for soot or scale.

Figure 12 - Burner Access Door

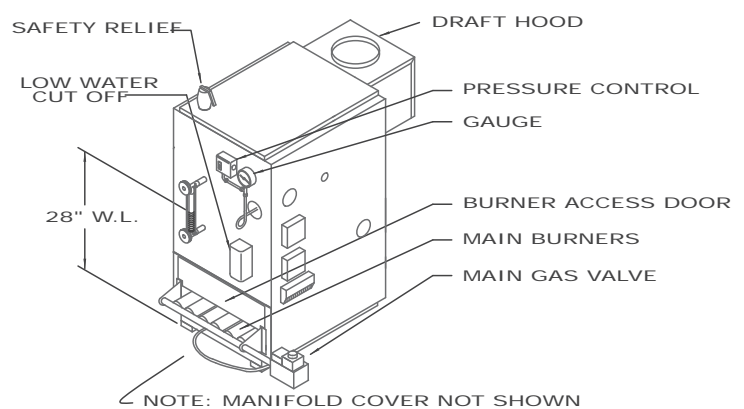

CLEANING BOILER FLUE-WAYS

To Clean The Boiler Flue-ways:

1. Remove the burners from the combustion chamber by raising the burners upward from the manifold orifices and pulling toward the front of the boiler. To remove the burner with the pilot burner attached, first disconnect the pilot line tubing and thermocouple or pilot generator leads at the main electric gas valve. Do not remove the pilot line tubing at the pilot as the pilot burner orifice may drop out and become damaged or lost.
2. Disconnect the vent pipe from the draft hood.
3. Remove the draft hood. The draft hood is attached to the flue collector at the top by sheet metal screw(s).
4. Remove the top jacket panel. It is attached to the jacket by sheet metal screws.
5. Remove the flue collector from the boiler casting by loosening the nuts on the "J" bolts at either side of the flue collector.
6. Place a sheet of heavy paper or similar material over the bottom of the combustion chamber and brush down the flue passageways. The soot and scale will collect on the paper and is easily removed with the paper.
7. With the paper still in place in the combustion chamber, clean the top of the boiler castings of the boiler putty or silicone used to seal between the castings and the flue collector. Make certain chips are not lodged in the flue-ways.
8. When the cleaning process is completed, restore the boiler components to their original position. Use boiler putty or GE IS-808 silicone to seal around the flue collector and castings. Make certain the burner ends are inserted in the slots at the back of the combustion chamber and well down in position over the burner orifices. Follow the lighting instructions on the boiler to put the burners back in operation.

Check Safety Control Circuit, after burner adjustments are made, for satisfactory operation.



CAUTION

Label all wires prior to disconnection when servicing controls. Wiring errors can cause improper and dangerous operation.

Verify proper operation after servicing.

1. Pilot: with main burner operating turn the pilot gas adjusting screw clockwise  until pilot gas is turned off. See figures 8 and 9 on page 17. Within 90 seconds the main gas control should close, shutting off the gas to the main burner. After checking pilot operation, relight following lighting instructions on pages 16-17.
2. Pressure control - on steam boilers - remove cover and note pressure setting. With the boiler operating, decrease the setting. When setting is lower than boiler pressure, the control will open, closing the automatic main gas valve. After checking pressure control, reset control to original setting.
3. Mechanical Low water cut-off: Operation may be checked by opening the blow-off valve located in the lower portion of the body. This will drain water quickly from the cut-off body and break circuit to automatic main gas valve. Owner should blow off this control at least once each month of the heating season.



WARNING

Water will be boiling hot water.

4. Electronic Low Water Cut-off: Operation may be checked by opening the drain valve in the back side of the boiler. This will drain the water from the boiler and break the electronic circuit to the automatic gas valve.

IMPURITIES IN BOILER WATER of a steam boiler may cause foaming and an unsteady water line, or prevent steam generation. They may result in objectionable odors escaping from the vents on water boilers. This condition is caused by oil, grease, and sediment from pipe fittings collecting within the boiler and can be remedied only by giving the boiler a thorough cleaning.

BOILERS CAN BE CLEANED by skimming or blowing down.



CAUTION

Boiler should not be left unattended during cleaning process.

Skimming Off Impurities

- Some of the impurities in the boiler water will float on the water and must be skimmed off.
- With the boiler empty and cool, slowly begin to add water. After water has entered boiler - never before - turn "on" main gas burners and adjust flame at main manual shut-off valve so that the water being added is kept just below boiling point. Avoid boiling and turbulence. Gradually raise hot water level to skimming tee, see figure 1, installed at the supply outlet piping of the boiler being careful not to raise it above the opening of the tee. Skim until there are no impurities. Repeat the process if necessary.
- Water may be checked to make sure it is free from oil by drawing off a sample at the skimming tee. If the sample is reasonably free from oil, it will not froth when boiled on stove. This test does not indicate the amount of sediment which may lay in the bottom of the boiler. It is therefore necessary that the boiler be further cleaned by "blowing down".

Blowing Down Boiler

- Before blowing down the boiler, fill it to the water line. Light burners and allow five pounds of steam pressure to build up. Run a temporary connection from one of the drain valves to a nearby sewer. Connect to a drain valve on the opposite end of the boiler from feed water inlet, if possible. Shut off the gas burners, open drain valve and blow down the entire contents of boiler.
- Allow boiler to thoroughly cool and slowly refill to water line. Repeat step 2 as many times as required until blow off water is clear. Owner should blow down boiler at least once each month of the heating season.



WARNING

Water will be boiling hot water.

Using Cleaning Compound

- If an exceptional amount of dirt or sludge seems to be present in the boiler, a boiler cleaning compound made by a reputable manufacturer may be used according to the instructions of the manufacturer of the compound. When any type of cleaning compound is used, care must be taken to thoroughly flush all traces of the compound out of the boiler.
- Following blow down allow the boiler to cool. Add fresh water slowly. Be certain to blow enough times as required to remove compounds from system.

Checking And Adjusting The Gas Ignition Components



- The gas input to the boiler can be adjusted by removing the protective cap on the pressure regulator, see figure 8 or 9 , and turning screw clockwise  to increase input and counterclockwise  to decrease input.
- Natural gas manifold pressure should be set at approximately 3.5 inches water column. Propane gas manifold pressure should be set at approximately 10 inches water column.
- Manifold pressure is taken at the pressure tap on the outlet side of the gas valve, see figures 8 and 9.
- Burner orifices should be changed if the final manifold pressure varies more than plus or minus 0.3 inch water column from the specified pressure.
- To check for proper flow of natural gas to boiler divide the input rate on the rating plate by heating value of the gas as obtained from the local gas company. This will determine the number of cubic feet of gas required per hour. With all other gas appliances off, determine the flow of gas through the meter for two minutes and multiply by 30 to get the hourly rate. Make minor adjustments to the gas input as described above.
- Primary air adjustment is not necessary, therefore air shutters are not furnished as standard equipment. Air shutters can be furnished on request when required by local codes or conditions.
- A visual check of the main burners and pilot flames should be made at the start of the heating season and again at mid-season.
- The main burner flame should have a well defined inner blue mantel with a lighter blue outer mantel. If the flame does not appear this way, check the burner throats and burner orifices for lint or dust obstruction. See figure 14.
- The pilot flame should envelop 3/8 to 1/2 inch of the tip of the pilot sensor. See figure 15. To adjust the pilot flame, remove the pilot adjustment screw and turn the inner adjustment screw clockwise to decrease or counterclockwise to increase pilot flame. See figures 8 and 9. Be sure to replace cover screw after adjustment to prevent possible gas leakage.

Figure 13 - Gas Control Assembly



- The burners and pilot should be checked for signs of corrosion, rust or scale build-up. Clean corrosion and rust with wire brush or replace as necessary.
- The area around the boiler should be kept clear and free of combustible materials, gasoline and other flammable vapors and liquids.
- The free flow of combustion and ventilation air to the boiler and boiler room should not be restricted or blocked.
- It is suggested that a qualified service agency be employed to make an annual inspection of the boiler, vent system and low water cutoff (including flushing of float types) and heating system. They are experienced in making the inspections outlined above and, in the event repairs or corrections are necessary, can make the proper changes for safe operation of the boiler.

Figure 14 - Main Burner Flame

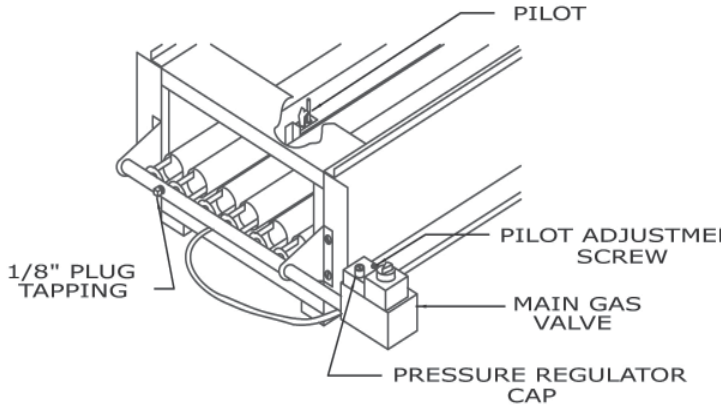
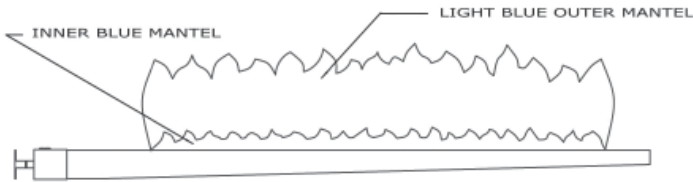
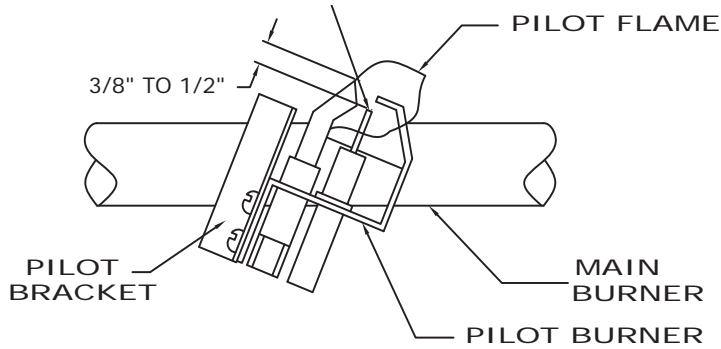
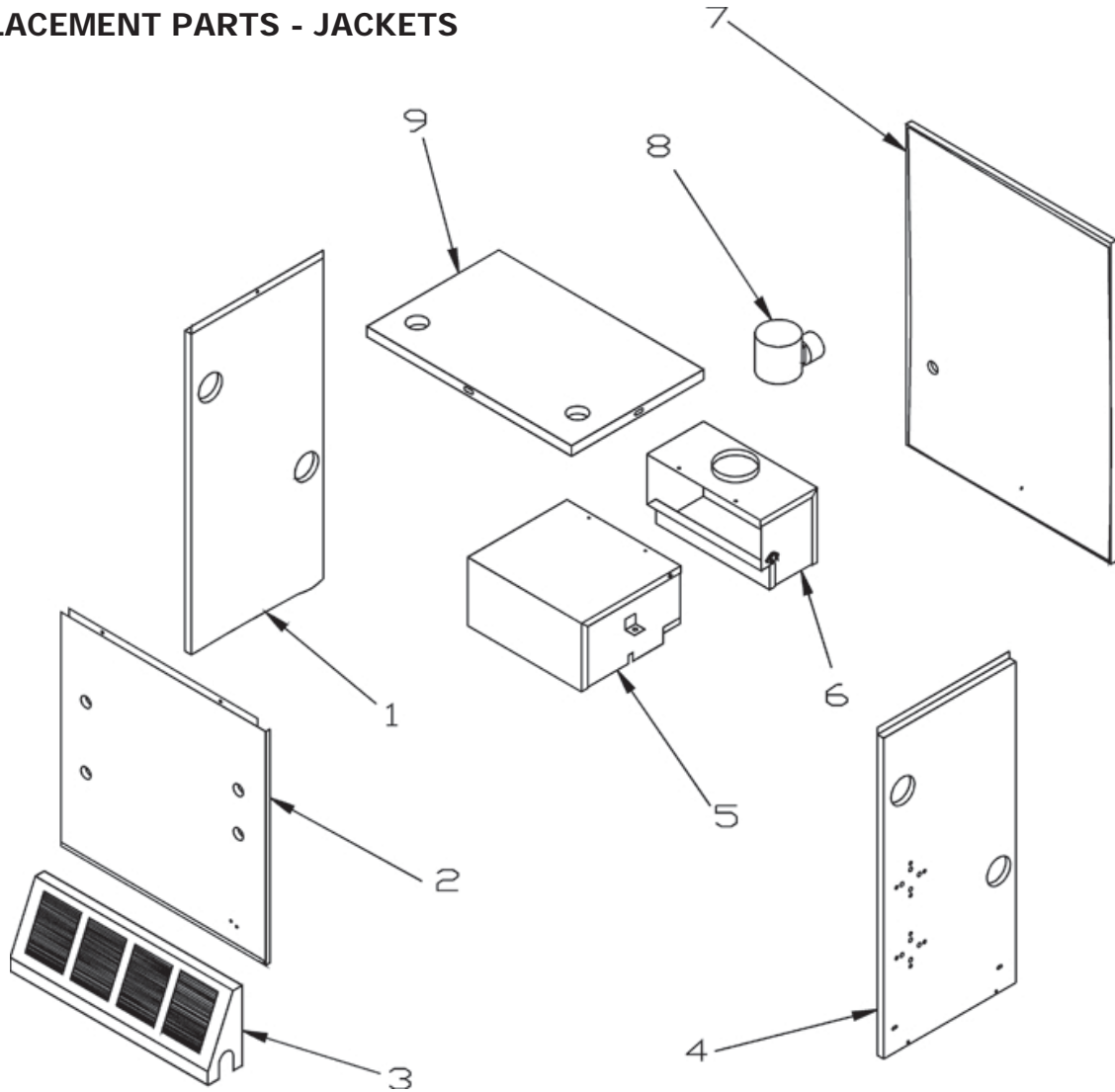

Figure 15 - Pilot Burner Flame



CEG-C REPLACEMENT PARTS

CEG-C REPLACEMENT PARTS - JACKETS



ITEM #	PART NUMBER	DESCRIPTION	QTY.	ITEM #	PART NUMBER	DESCRIPTION	QTY.
1	31423001	SIDE PANEL LEFT (ALL)	1	6	344-2-1.02	DRAFT HOOD CEG112C	1
2	31422802	FRONT PANEL CEG112C	1		344-2-1.03	DRAFT HOOD CEG150C	
	31422803	FRONT PANEL CEG150C			344-2-1.04	DRAFT HOOD CEG187C	
	31422804	FRONT PANEL CEG187C			344-2-1.05	DRAFT HOOD PEG225C	
	31422805	FRONT PANEL CEG225C			344-2-1.06	DRAFT HOOD PEG262C	
	31422806	FRONT PANEL CEG262C			344-2-1.07	DRAFT HOOD CEG300C	
	31422807	FRONT PANEL CEG300C		7	31423302	REAR PANEL CEG112C	1
3	31421002	MANIFOLD COVER CEG112C	1		31423303	REAR PANEL CEG150C	
	31421003	MANIFOLD COVER CEG150C			31423304	REAR PANEL CEG187C	
	31421004	MANIFOLD COVER CEG187C			31423305	REAR PANEL CEG225C	
	31421005	MANIFOLD COVER CEG225C			31423306	REAR PANEL CEG262C	
	31421006	MANIFOLD COVER CEG262C			31423307	REAR PANEL CEG300C	
	31421007	MANIFOLD COVER CEG300C		8	240005972	DAMPER CEG112C 5"	1
4	31423002	SIDE PANEL RIGHT (ALL)	1		240005973	DAMPER CEG150C 6"	
5	3442702	FLUE COLLECTOR CEG112C	1		240005974	DAMPER CEG187C 7"	
	3442703	FLUE COLLECTOR CEG150C			240005975	DAMPER CEG225C&262C 8"	
	3442704	FLUE COLLECTOR CEG187C			240005976	DAMPER CEG300C 9"	
	3442705	FLUE COLLECTOR CEG225C		9	31423502	TOP PANEL CEG112C	1
	3442706	FLUE COLLECTOR CEG262C			31423503	TOP PANEL CEG150C	
	3442707	FLUE COLLECTOR CEG300C			31423504	TOP PANEL CEG187C	
					31423505	TOP PANEL CEG225C	
					31423506	TOP PANEL CEG262C	
					31423507	TOP PANEL CEG300C	

CEG-C REPLACEMENT PARTS - HEAT EXCHANGER

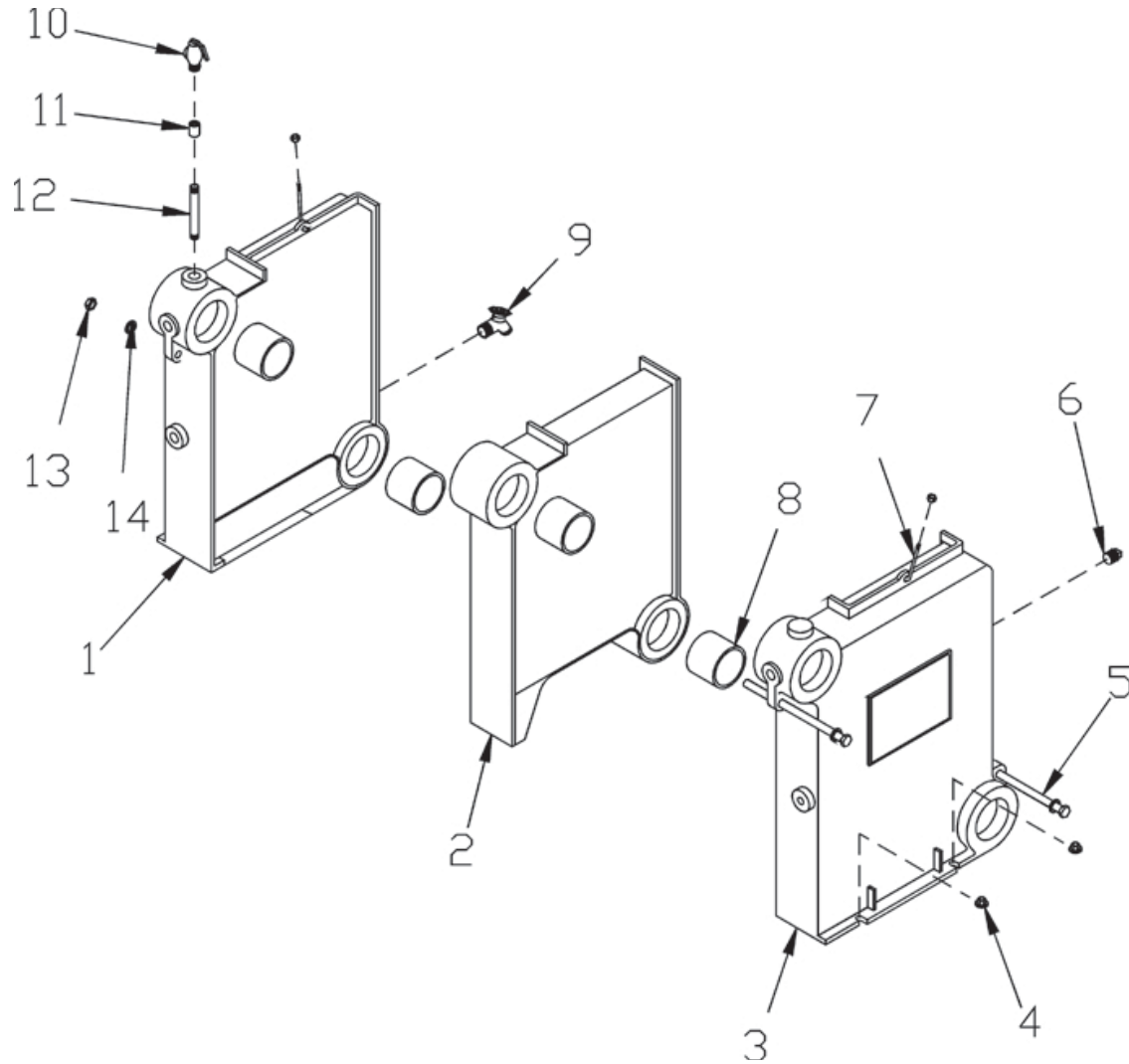

ITEM #	PART NUMBER	DESCRIPTION	QTY.	ITEM #	PART NUMBER	DESCRIPTION	QTY.
1	100-2-15.01	E-Left Hand Section	1	13	HW-003.02	NUT-1/4-20 HEX SLT	4
2	100-2-14.01	E-Center Section	1	14	HW-008.01	WASH 5/16 FLAT STL ZP	2
CEG112C - (2), CEG150 - (3), CEG187 - (4), CEG 225 - (5), CEG262 - (6), CEG300 - (7)				(Fully assembled heat exchangers.)			
3	100-2-13.02	E-Right Hand Section	1	10022802	4 SECTION	CEG112C	1
4	HW06901	NUT-5/16-18 WISLOCK	4	10022803	5 SECTION	CEG150C	1
5	HW-011.10	TIE ROD 1/4X10.25	2	10022804	6 SECTION	CEG187C	1
	HW-011.02	TIE ROD 1/4X13	CEG150	10022805	7 SECTION	CEG225C	1
	HW-011.04	TIE ROD 1/4X17	CEG187	10022806	8 SECTION	CEG262C	1
	HW-011.05	TIE ROD 1/4X19	CEG225	10022807	9 SECTION	CEG300C	1
	HW-011.07	TIE ROD 1/4X23	CEG262				
	HW-011.08	TIE ROD 1/4X25	CEG300				
6	PF-007.02	PIPE FIT PLG 2"	1				
7	251-1-2.00	J-BOLT 1/4-20X3.5/16	2				
8	43300976	NIPPLE 2" MACH.					
CEG112C - (4), CEG150 - (6), CEG187 - (8), CEG 225 - (10), CEG262 - (12), CEG300 - (14)							
9	HW-016.02	DRAIN LONG	1				
10	1570001	VALVE, POP SAFETY 3/4"	1				
11	1150001	COUPLING 3/4"	1				
12	PF-005.10	PIPE FIT NPL 3/4"X 6"	1				

CEG-C REPLACEMENT PARTS - FRONT PANEL CONTROLS

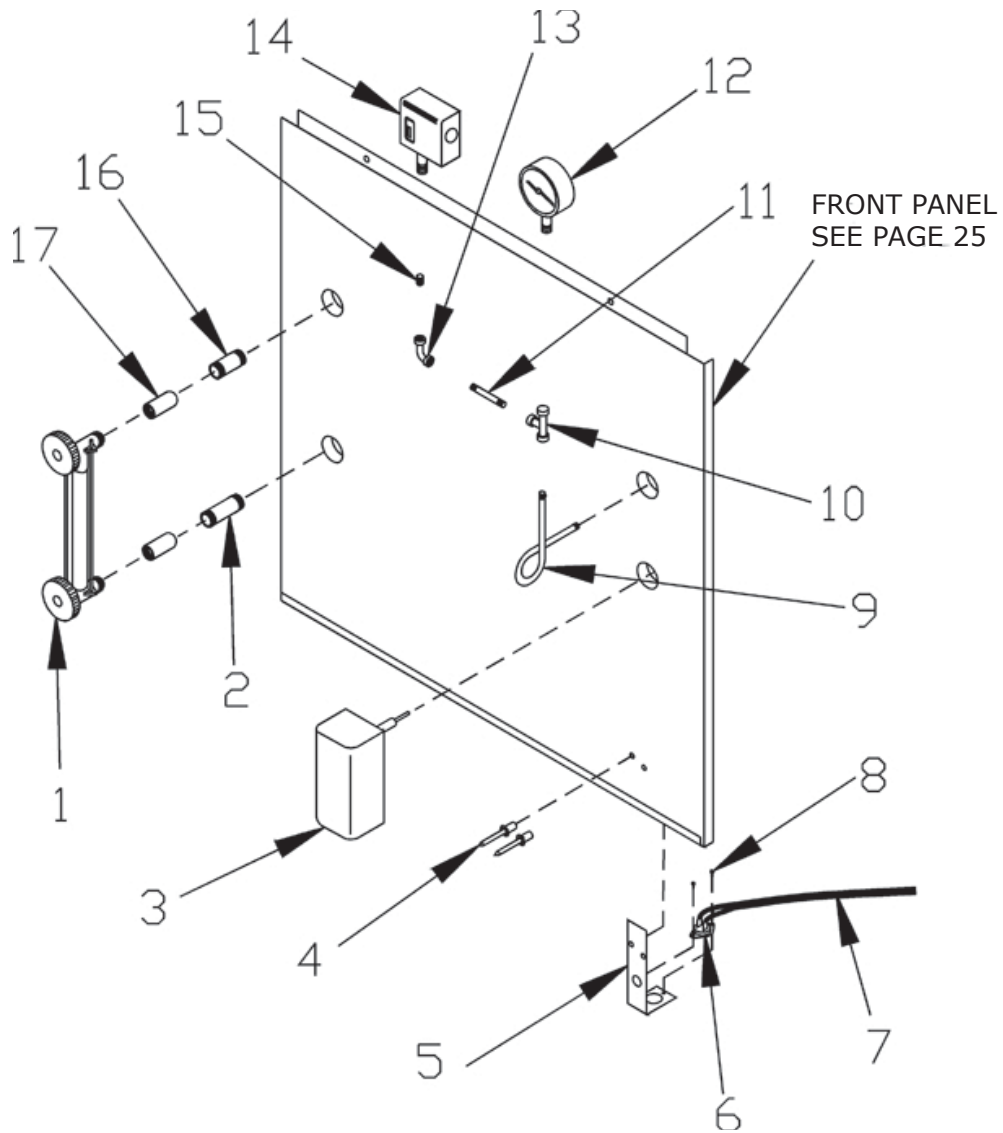

ITEM #	PART NUMBER	DESCRIPTION	QTY.	ITEM #	PART NUMBER	DESCRIPTION	QTY.
1	GA-004.00	GAUGE WTR LEVEL	1	10	PF-025.01	1/4" TEE	1
2	PF-033.02	PIPE FIT NPL 1/2"X4"	1	11	PF-026.05	1/4" X 3" NIPPLE	1
3	WCO1901	ELWCO PS-802U-24 WITH PROBE	1	12	GA-003.00	PRESSURE GAUGE	1
4	HW-006.02	POP RIVIT FLUE 3/16"	2	13	PF-027.01	1/4" ELBOW 90°	1
5	32421901	SENSOR BRACKET	1	14	SS-001.01	PRESSURE SWITCH	1
6	AQ02101	CONTROL FIXED TEMP (ONE ON DRAFT HOOD)	2	15	PF-026.01	CLOSE NIPPLE 1/4" NPL	1
7	37513301	WIRE - ROLL OUT	1	16	PF05601	PIPE FIT NPL 1/2"X3"	1
8	HW06501	SCR 6X1/4" SLOT	2	17	PF-034.01	1/2" BRASS COUPLING	2
9	753-1-3.00	90° SYPHON	1				

CEG-C REPLACEMENT PARTS - ELECTRICAL

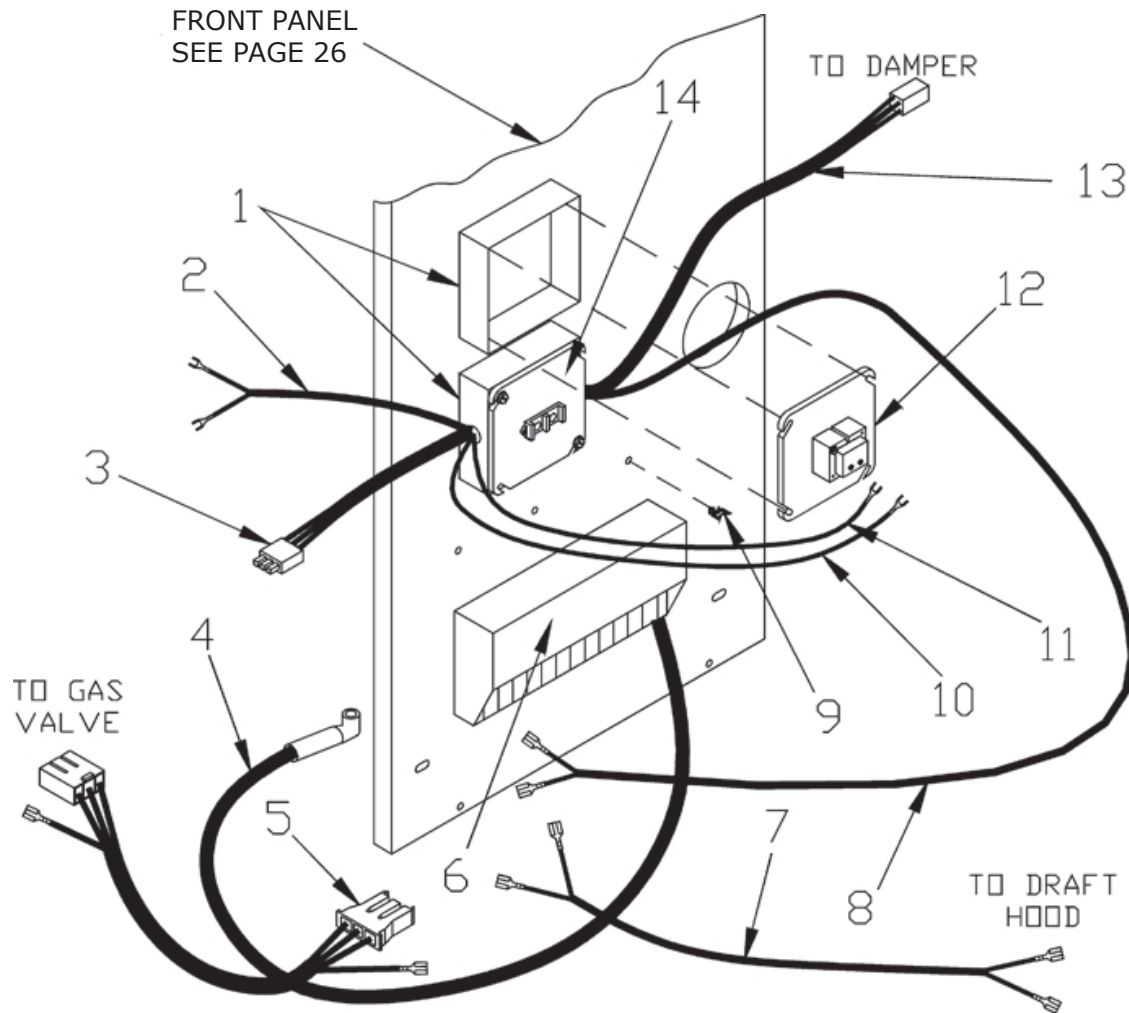

ITEM NUMBER	PART NUMBER	DESCRIPTION	QTY.
1	EF-013.01	ELEC. J-BOX 4X4X1/2	2
2	37414401	WIRE PRES. SWITCH TO J-BOX 34"	1
3	37424501	HARNESS-ELWCO TO J-BOX 18"	1
4	PB00702	IGN WIRE 30" CIDE MODELS ONLY	1
5	37413602	HARNESS IGN. MOD. TO GAS VALVE 12"	1
6	PB00604	SPK CTL S8600M1013	1
7	37413201	WIRE SPILL SWITCH 47"	1
8	37413801	WIRE J-BOX TO CONTROLS 27"	1
9	EF03601	WIRE CLAMP #3600 WHITE	1
10	37413002	WIRE TRANSFORMER (WHITE) 15"	1
11	37413001	WIRE TRANSFORMER (BROWN) 15"	1
12	3641601	TRANSFORMER ASSEMBLY 24V	1
13	37413101	DAMPER CABLE 53"	1
14	3641501	ELEC 4"X4" COVER/TERM STRIP	1

RATINGS, DATA, AND DIMENSIONS

NATURAL GAS STEAM BOILERS

Boiler Number & Damper	Input Btu/Hr.	Heating Capacity Btu/Hr.	Net Steam Rating		Gas Inlet Size	Dimensions							Water Content (Gallon Capacity)		Annual Fuel Utilization Efficiency (AFUE)	
			Btu/Hr.	Sq. Ft.		A	B	C	D	E	F	G	To Water Line	To LWCO Line	Elec. Ign.	Std. Pilot
CEG112C	112,500	90,000	67,500	281	1/2	14 1/4	27 5/8	24 1/8	5	3 1/2	6	44 3/4	4.8	3.0	81.0	78
CEG150C	150,000	120,000	90,000	375	1/2	17 1/8	28 5/8	24 5/8	6	4	6 1/2	45 1/4	6.0	3.7	81.0	78
CEG187C	187,000	151,000	113,300	472	1/2	20	29 5/8	25 1/8	7	4 1/2	7	45 3/4	7.0	4.4	81.0	78
CEG225C	225,000	181,000	135,800	556	3/4	22 13/16	30 5/8	25 5/8	8	5	8	46 3/4	8.4	5.0	81.0	78
CEG262C	262,500	212,000	159,000	663	3/4	25 5/8	30 5/8	25 5/8	8	5	8	46 3/4	9.5	5.8	81.0	78
CEG300C	299,999	243,000	182,300	760	3/4	28 1/8	31 5/8	26 1/8	9	5 1/2	10	48 3/4	10.7	6.4	81.0	78

NOTE: For altitudes above 2,000 ft. ratings should be reduced at the rate of 4% for each 1,000 ft. above sea level, The MEA number for the CEG series is 17-79.
 Electrical service to be 120 Volts, 15 Amps, 60 Hz.
 **For equivalent square feet of radiation, divide output by 240.

STANDARD EQUIPMENT: Crafted Boiler, Draffhood, Low Water Cut-off (Probe Type), Deluxe Jacket, Wiring, Automatic Vent Damper, Ported Stainless Steel Burners, Blocked Vent and Roll-Out Safety Switches, Gas Valve, Pilot, Pressure High Limit Control, 2-2" Supply Tapping-L.H. Plugged, 2-2" Return Tappings-L.H. Plugged. Packed in Separate Carton: Pop Safety Valve and Boiler Drain.

OPTIONAL EQUIPMENT: Electronic water feeder

The Ratings marked "Net" indicate the amount of equivalent direct cast iron radiation each boiler will take care of under normal conditions and thermostatic control. The Net Steam Ratings shown are based on a piping and pickup allowance of 1.333. Proper allowance has been made for piping and pickup in accordance with the factors shown in the Standard as published by The Hydronics Institute.

Selection of boiler size should be based upon Net BTU per Hour of the connected radiation and piping.

The manufacturer should be consulted before selecting a boiler for installations having unusual piping and pickup requirements.

In line with it's policy of product improvement, Utica Boilers reserves the right to make changes without notice.

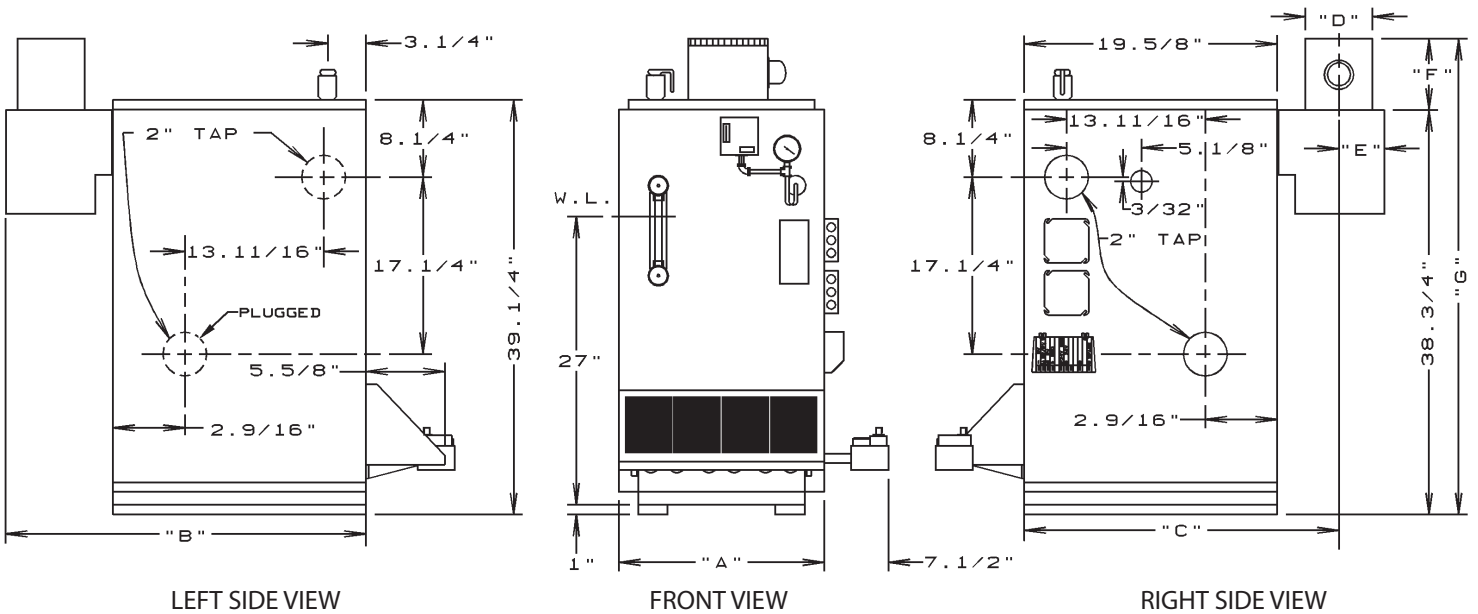

INSTALLATION NOTES

INSTALLATION NOTES



COLUMBIA COMPANY
Main offices and factory
Pottstown, PA