

# USER'S INFORMATION MANUAL SERIES CEG-C

## GAS FIRED HOT WATER OR STEAM HEATING BOILER

**WARNING:** If the information in this manual is not followed exactly, a fire or explosion may result causing property damage, personal injury or loss of life.

- Do not store or use gasoline or other flammable vapors and liquids in the vicinity of this or any other appliance.
  
- WHAT TO DO IF YOU SMELL GAS
  - Do not try to light any appliance.
  - Do not touch any electrical switch; do not use any phone in your building.
  - Immediately call your gas supplier from a neighbor's phone. Follow the gas supplier's instructions.
  - If you cannot reach your gas supplier, call the fire department.
  
- Installation and service must be performed by a qualified installer, service agency or the gas supplier.

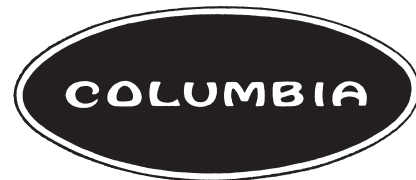

**COLUMBIA BOILER COMPANY**  
Main offices and Factory: Pottstown, PA

P/N 37412501, Rev. A [2/2011]

## **1 - GENERAL**

### **1.1 General**

This boiler has few user serviceable parts. Maintenance and Service must be completed by qualified agency.

Determine if ignition system is electric or standing pilot before any procedure is attempted. If you are uncertain, contract manufacturer before proceeding.

#### **WARNING**

Fire, explosion, asphyxiation and electrical shock hazard. Improper maintenance and service could result in death or serious injury. Read this manual and understand all requirements, including use of qualified agency where directed.

### **1.2 Become familiar with symbols identifying potential hazards.**



This is the safety alert symbol. Symbol alerts you to potential personal injury hazards. Obey all safety messages following this symbol to avoid possible injury or death.

#### **⚠ DANGER**

Indicates a hazardous situation which, if not avoided, WILL result in death or serious injury

#### **⚠ WARNING**

Indicates a hazardous situation which, if not avoided, could result in death or serious injury.

#### **⚠ CAUTION**

Indicates a hazardous situation which, if not avoided, could result in minor or moderate injury.

#### **NOTICE**

Used to address practices not related to personal injury.

### **1.3 WHAT TO DO SHOULD OVERHEATING OCCUR**

Do not turn off or disconnect electrical supply to pumps. Shut off gas supply at location external to appliance.

### **1.4 WHAT TO DO IF BOILER OR ANY PART HAS BEEN UNDER WATER**

Do not use boiler if any part has been under water. Immediately call a qualified service technician to inspect boiler and to replace any part of control system and any gas control which has been under water.

## 2 - OPERATING INSTRUCTIONS INTERMITTENT PILOT SYSTEM

### FOR YOUR SAFETY READ BEFORE OPERATING

#### ⚠ CAUTION

Before operating boiler, make certain hot water boiler and system are full of water and vented of air, or steam boiler is full of water to water line.

### 2.1 LIGHTING PROCEDURE FOR INTERMITTENT PILOT SYSTEM.

#### ⚠ WARNING

**If you do not follow these instructions exactly, a fire or explosion may result causing property damage, personal injury or loss of life.**

- This appliance is equipped with an ignition device which automatically lights pilot. **Do NOT try to light this pilot by hand.**
- Before operating smell all around appliance area for gas. Be sure to smell next to floor because some gas is heavier than air and will settle to the floor.
- **Use only your hand to turn the gas shutoff knob.** Never use tools. If knob will not turn by hand, do not try to repair it, call a qualified service technician. Force or attempted repair may result in fire or explosion.
- **Do not use this appliance if any part has been under water.** Immediately call a qualified service technician to inspect appliance and to replace any part of control system and any gas control which has been under water.

### 2.2 OPERATING INSTRUCTIONS

**Stop! Read Safety information above.**

1. Set thermostat to lowest setting.
2. Turn "OFF" all electrical power to appliance.
3. This appliance is equipped with an ignition device which automatically lights the pilot. **Do not try to light burner by hand!**
4. Remove access panel (if present).
5. Push in gas control knob slightly and turn clockwise ↻ to "OFF" position. See Figure 2-1. Knob cannot be turned "OFF" unless knob is pushed in slightly. Do Not Force.

6. Wait 5 minutes for any gas to clear. Smell for gas, including near floor. If you smell gas, **STOP!** Follow instructions on this page: "**What To Do If You Smell Gas.**" If you do **not** smell gas, go to next step.
7. Turn gas control knob counter clockwise ↺ to "ON" position. See Figure 2-1.
8. Replace front control access panel (if present).
9. Turn "ON" electrical power to appliance.
10. Set thermostat to desired setting.
11. If the appliance will not operate, follow instructions TO TURN OFF GAS TO APPLIANCE and call your service technician or gas supplier.

#### ⚠ CAUTION

##### WHAT TO DO IF YOU SMELL GAS

- Do not try to light any appliance.
- Do not touch any electrical switch; do not use any phone in your building.
- Immediately call your gas supplier from a neighbor's phone. Follow the gas supplier's instructions.
- If you cannot reach your gas supplier, call the fire department.

### 2 -1 Intermittent Pilot Gas Valve

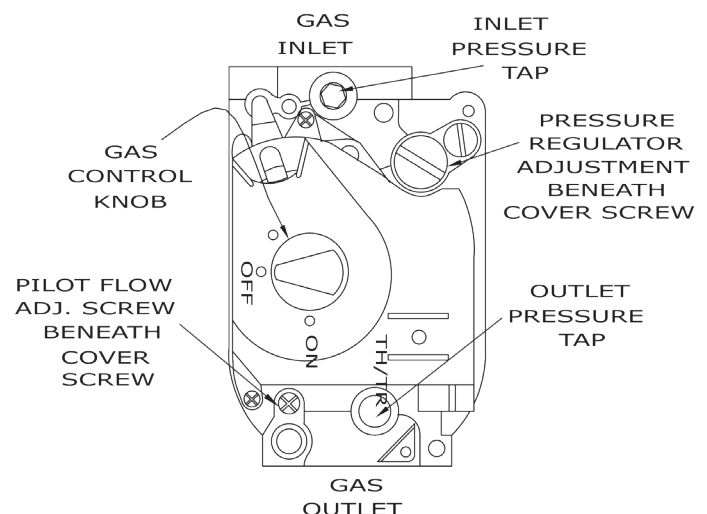

### **3 - LIGHTING INSTRUCTIONS CONTINUOUS PILOT SYSTEM**

#### **FOR YOUR SAFETY READ BEFORE LIGHTING.**

#### **⚠ CAUTION**

Before lighting pilot burner, make certain hot water boiler and system are full of water and vented of air, or steam boiler is full of water to water line.

#### **3.1 LIGHTING PROCEDURE FOR CONTINUOUS PILOT SYSTEM.**

#### **⚠ WARNING**

**If you do not follow these instructions exactly, a fire or explosion may result causing property damage, personal injury or loss of life.**

- This appliance is equipped with a pilot which must be lighted by hand. When lighting follow these instructions exactly.
- Before lighting smell all around appliance area for gas. Be sure to smell next to floor because some gas is heavier than air and will settle to the floor.
- **Use only your hand to push in or turn the gas control knob.** Never use tools. If knob will not turn by hand, do not try to repair it, call a qualified service technician. Force or attempted repair may result in fire or explosion.
- **Do not use this appliance if any part has been under water.** Immediately call a qualified service technician to inspect appliance and to replace any part of control system and any gas control which has been under water.

#### **3.2 LIGHTING INSTRUCTIONS**

**Stop! Read Safety information above.**

1. Set thermostat to lowest setting.
2. Turn **"OFF"** all electrical power to appliance.
3. Remove manifold cover and burner access door. See Figures 5-2 & 5-3.
4. Turn gas control knob clockwise ↻ to **"OFF"** position. See Figure 3-1. Some gas control knobs cannot be turned from "pilot" to "off" unless knob is pushed in slightly. Do Not Force.
5. Wait 5 minutes for any gas to clear. Smell for gas, including near floor. If you smell gas, **STOP!** Follow instructions on this page: **"What To Do If You Smell Gas."** If you do **not** smell gas, go to next step.

6. Find pilot. Follow metal tube from gas control. Pilot will be located on one of the burner tubes. See Figure 3-2.
7. Turn gas control knob counter clockwise ↻ to **"Pilot"** position. See Figure 3-1.
8. Push in gas control knob or reset button, if so equipped, all the way in and hold. Immediately light the pilot with a match. Continue to hold gas control knob or reset button in for about (1) minute after the pilot is lit. Release knob or button and it will pop back up. Pilot should remain lit. If it goes out repeat steps 4 through 8.
  - If button does not pop up when released, stop and immediately call your service technician or gas supplier.
  - If the pilot will not stay lit after several tries, turn gas control knob clockwise ↻ to **"OFF"**. Some gas control knobs cannot be turned from **"Pilot"** to **"OFF"** unless knob is pushed in slightly. Do Not Force.
9. Turn gas control knob counter clockwise ↻ to **"ON"** position.
10. Replace burner access door and manifold cover. See Figures 5-2 & 5-3.
11. Turn **"ON"** electrical power to appliance.
12. Set thermostat to desired setting.
13. If the appliance will not operate, follow instructions TO TURN OFF GAS TO APPLIANCE and call your service technician or gas supplier.

#### **⚠ CAUTION**

WHAT TO DO IF YOU SMELL GAS

- Do not try to light any appliance.
- Do not touch any electrical switch; do not use any phone in your building.
- Immediately call your gas supplier from a neighbor's phone. Follow the gas supplier's instructions.
- If you cannot reach your gas supplier, call the fire department.

## 4 - TO TURN OFF GAS TO APPLIANCE

### 3-1 Continuous Pilot Gas Valve

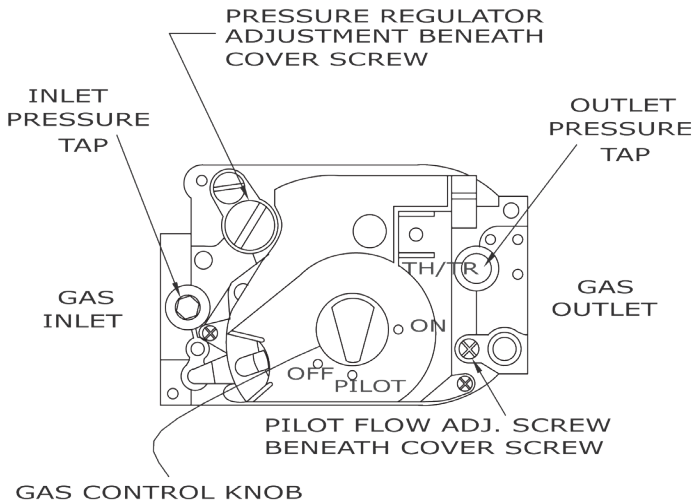

### 4.1 TO TURN OFF GAS TO APPLIANCE

- Set thermostat to lowest setting.
- Turn **"OFF"** all electric power to appliance if service is to be performed.
- Remove access panel (if present), and or burner cover plate.
- Turn gas control knob clockwise  to **"OFF"** position. Some gas control knobs cannot be turned from **"Pilot"** to **"OFF"** unless knob is pushed in slightly. Do Not Force.
- Replace control access panel (if present), and or burner cover plate.

### 3-2 Pilot Location

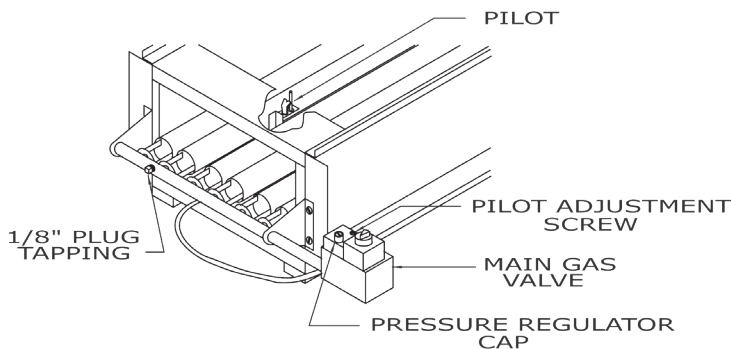

## 5 - GENERAL INSTRUCTIONS

### 5.1 SEASONAL START UP

- Before seasonal start up, it is advisable to have a competent service agency check boiler and scale in flues, clean burners, check gas input rate to maintain high operating efficiency.
- Service agency or homeowner should make certain system is filled with water to minimum pressure and open vents, if used, to expel any air accumulated in system. Check entire piping system. Have any leaks repaired.
- On steam boilers make certain boiler is filled to water line as indicated in Figure 5-1. Gauge valves should normally be open. To remove dirt from gauge glass, petcock may be opened to flush out glass.

#### **⚠ WARNING**

Burn and scald hazard. Discharge may be boiling water. Take appropriate care to cool boiler before flushing.

- Radiator valves on one-pipe steam system must be either wide open or tightly shut. Do not attempt to regulate room temperature by partially closing radiator valve.
- Air vents on steam radiators and supply main release air from system. If radiators do not heat satisfactorily, make sure air vents are clean and operating.
- Operate safety valve on boiler; should be operated periodically to ensure it is functioning properly. See Figure 5-2.

#### **⚠ WARNING**

Burn and scald hazard. Verify Safety Relief Valve discharge piping run to safe discharge location before conducting maintenance procedure. Contact qualified agency to correct improper piping.

- Safety valve should open before steam pressure exceeds 15 lb reading on gauge. If pressure is exceeded and safety valve does not open, it must be replaced. If safety valve leaks steam when boiler is operating at normal pressures, it should be immediately replaced. Corrosion can build up rapidly at the valve seat and prevent its functioning as a safety device. See Figure 5-2.
- During heating season owner should blow down boiler at least once each month. Before blowing down the boiler, fill it to water line. Light burners and allow 5 lbs of steam pressure to build up. Run temporary connection from one of the drain valves to a nearby sewer. Connect to drain valve on opposite end of boiler from feed water inlet, if possible. Shut off gas burners, open drain valve and blow down entire contents of boiler.

### 5-1 Water Line on Steam Boiler

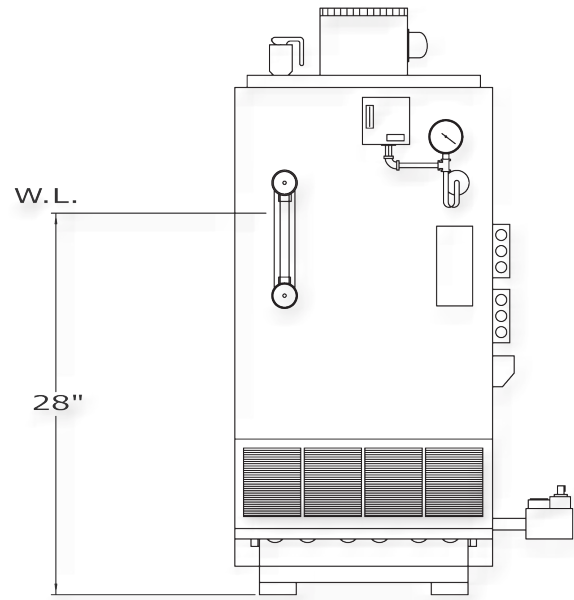

### 5-2 Safety Valve Location

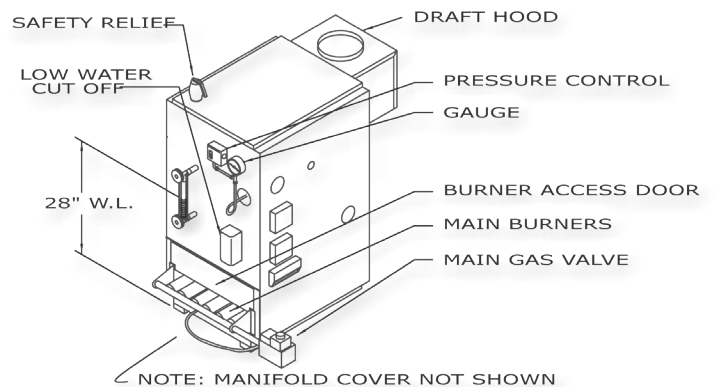

### 5-3 Blocked Safety Valve Switch

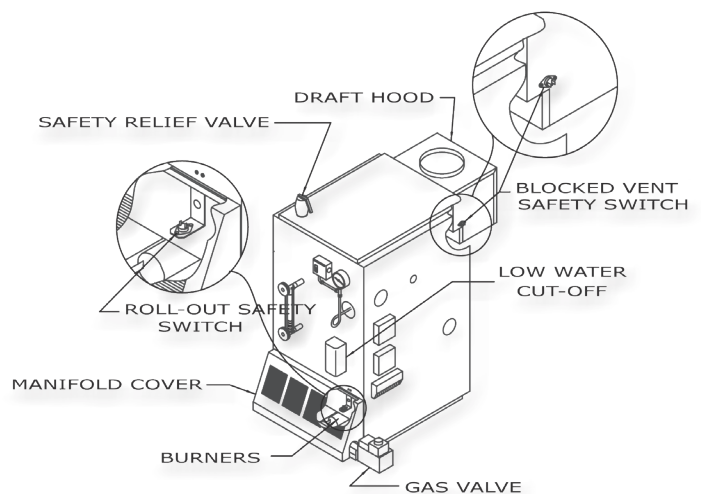

## 5 - GENERAL INSTRUCTIONS

### 5-4 Draft Hood

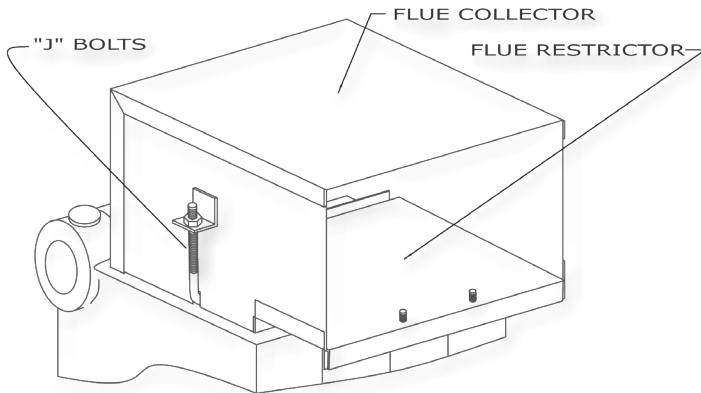

### 5-5 Flame Mantel

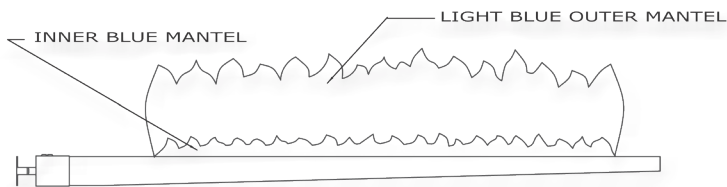

### 5-6 Pilot Flame

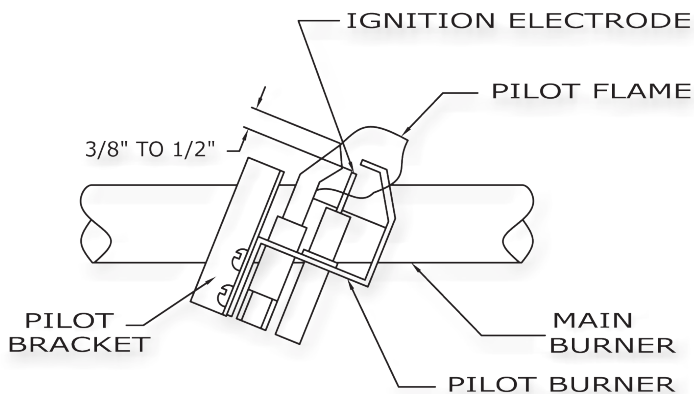

- Allow boiler to thoroughly cool and slowly refill to water line. Repeat process until blow off water is clear.

#### **⚠ WARNING**

Burn and scald hazard. Discharge may be boiling water. Take appropriate care to cool boiler before flushing.

- Boilers with electronic low water cutoffs, following test should be made to test low water cutoff device for proper operation. While burner is on, drain water from boiler until water is below probe. See Figure 5-2.

#### **⚠ WARNING**

Burn and scald hazard. Discharge may be boiling water. Take appropriate care to cool boiler before flushing.

- Burner should shut off after 10 to 25 seconds. If it does not, replace control. Refill boiler to normal water line.
- If water in a steam boiler appears to be dirty or oily, or water level in gauge glass fluctuates considerably, boiler should be cleaned. A competent service person will use approved cleaning compounds and properly clean and flush boiler.
- Service person should also clean or replace air vents and traps, clean flue passages and check for proper operation of all controls and safety devices.
- Venting system should be inspected at start of each heating season.
  - Check vent pipe from boiler to chimney for signs of deterioration by rust or sagging joints. Repair if necessary.
  - Remove vent pipe at base of chimney or flue and, using a mirror, check for obstruction.
  - In event flow of combustion products through boiler venting system becomes blocked, a blocked safety switch will shut main burner off. See Figure 5-3.

#### **⚠ WARNING**

Do not attempt to place boiler in operation. Contact a qualified service agency.

## **5 - GENERAL INSTRUCTIONS**

### **5.2 CLEANING BOILER FLUEWAYS**

- Boiler flue gas passageways may be inspected by a light and mirror.
- Remove burner cover plate. See Figure 5-2.
- Place trouble lamp in flue collector through draft hood relief opening. With mirror positioned above burners, flue gas passageways can be checked for soot or scale.
- If boiler flue-way becomes blocked, a flame rollout safety switch will shut main burner gas off. See Figure 5-3.

#### **⚠ WARNING**

Do not attempt to place boiler in operation. Contact a qualified service agency.

- Remove burners from combustion chamber by raising burners upward from manifold orifices and pulling toward front of boiler. To remove burner with pilot burner attached, first disconnect pilot tubing and thermocouple or pilot generator leads at main electric gas valve. Do not remove pilot line tubing at pilot as pilot burner orifice may drop out and become damaged or lost.
- Disconnect vent pipe from draft hood.
- Remove draft hood. Draft hood is attached to flue collector at top by sheet metal screw(s).
- Remove top jacket panel. It is attached to jacket by sheet metal screws.
- Remove flue collector from boiler casting by loosening nuts on "J" bolts at either side of flue collector. See Figure 5-4.
- Place sheet of heavy paper or similar material over bottom of combustion chamber and brush down flue passageways. Soot and scale will collect on paper and is easily removed with the paper.
- With paper still in place in combustion chamber, clean top of boiler castings of boiler putty or silicone used to seal between castings and flue collector. Make certain that chips are not lodged in flue-ways.

### **5.3 WHEN CLEANING PROCESS IS COMPLETED**

- Restore boiler components to their original position.
- Use boiler putty or GE IS-808 silicone to seal around flue collector and castings.
- Make certain burner ends are inserted in slots at back of combustion chamber and down in position over burner orifices.
- Follow lighting instructions on boiler to put burners back in operation.
- Visual check of main burners and pilot flames should be made at start of heating season and again at mid-season.
- Main burner flame should have well defined inner blue mantel with lighter blue outer mantel. If flame does not appear this way, check burner throats and burner orifices for lint or dust obstruction. See Figure 5-5.
- Pilot flame should envelop 3/8 to 1/2 inch of tip of pilot generator or thermocouple. See Figure 5-6.
- To adjust pilot flame, remove pilot adjustment screw, and turn inner adjustment screw clockwise ↻ to decrease or counter clockwise ↻ to increase pilot flame. See Figures 2-1 & 3-1.
- Burners and pilot should be checked for signs of corrosion, rust or scale buildup.

#### **⚠ WARNING**

Area around boiler should be kept clear and free of combustible materials, gasoline and other flammable vapors and liquids.

Free flow of combustion and ventilation air to boiler and boiler room must not be restricted or blocked.

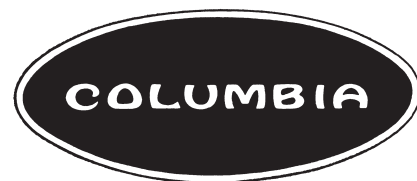

**COLUMBIA BOILER COMPANY**  
Main offices and Factory: Pottstown, PA