

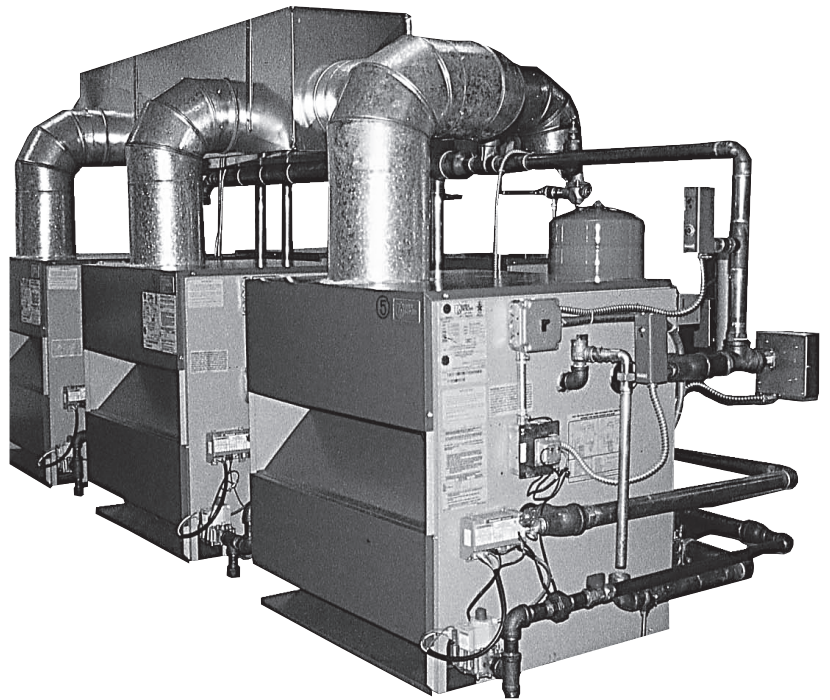

MAGB SERIES

Gas Fired Modu-Pac Multiple Commercial Boiler System

INSTALLATION, OPERATION & MAINTANANCE MANUAL



An ISO 9001-2000 Certified Company

UTICA BOILERS

P.O. Box 4729

Utica, NY 13504-4729

MEMBER: The Hydronics Institute

P/N 37518701, Rev. C [12/11]

MAGB SERIES GAS FIRED BOILERS FOR FORCED HOT WATER INSTALLATION MANUAL AND OPERATING INSTRUCTIONS

TABLE OF CONTENTS

Boiler Ratings & Capacities	2
Typical Layouts For Gas Fired Systems.....	4
Supply And Return Piping.....	5
Installation Procedure.....	5
Ventilation And Combustion Air	6
Vent Installation	8
Vent System Modification	9
Connecting Boilers With Refrigeration Systems ...	10
Connecting Gas Service.....	11
Electrical Wiring.....	12
Lighting Instructions	14
Normal Sequence of Operation	15
General Instructions	16
Checking Gas Input Rates To Boiler	18
Optional Controls & Wiring	18
MAGB Series Replacement Parts	20

SAFETY SYMBOLS

The following defined symbols are used throughout this manual to notify the reader of potential hazards of varying risk levels.

DANGER



Indicates an imminently hazardous situation which, if not avoided, **WILL** result in death, serious injury or substantial property damage.

WARNING



Indicates an imminently hazardous situation which, if not avoided, **MAY** result in death, serious injury or substantial property damage.

CAUTION



Indicates an imminently hazardous situation which, if not avoided, may result in injury or property damage.

KEEP THIS MANUAL NEAR BOILER AND RETAIN FOR
REFERENCE.

NOTICE

Read the following instructions **COMPLETELY** before installing!

2. To the owner: Installation and service of this boiler must be performed by a qualified installer.
3. To the installer: Leave all instructions with the boiler for future reference.



BOILER RATINGS & CAPACITIES

WARNING



All installations of boilers and venting should be done only by a qualified expert and in accordance with the appropriate manual. Installing or venting a boiler or any other gas appliance with improper methods or materials may result in serious injury or death due to fire or to asphyxiation from poisonous gases such as carbon monoxide which is odorless and invisible.

BOILER dimensions

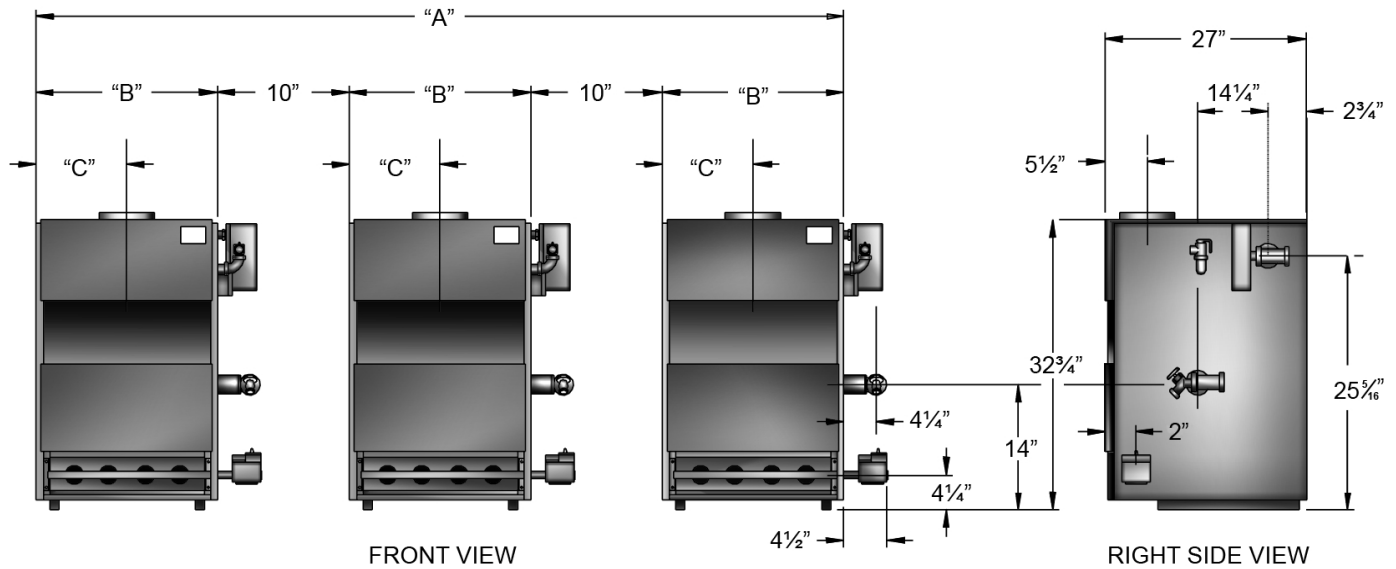

MAGB GAS FIRED BOILER SERIES ENGINEERING AND DIMENSIONAL DATA

MODEL NUMBER	NUMBER OF MODULES	SHIPPING WEIGHT (LBS.)	WATER CONTENT (GALLONS)	DIMENSIONS IN INCHES		
				A	B	C
MAGB500	2	945	17.6	62.250"	26.625"	13.313"
MAGB600	2	1065	20.8	70.000"	30.500"	15.250"
MAGB750	3	1400	26.4	97.875"	26.625"	13.313"
MAGB900	3	1600	31.2	109.500"	30.500"	15.250"
MAGB1000	4	1890	35.2	133.500"	26.625"	13.313"
MAGB1200	4	2135	41.6	149.000"	30.500"	15.250"
MAGB1500	5	2665	52.0	188.000"	30.500"	15.250"
MAGB1800	6	3200	62.4	228.000"	30.500"	15.250"
MAGB2100	7	3730	72.8	267.500"	30.500"	15.250"
MAGB2400	8	4265	83.2	307.000"	30.500"	15.250"

BOILER RATINGS & CAPACITIES

MAGB GAS FIRED BOILER SERIES ENGINEERING DIMENSIONAL DATA								
Model Number	AGA Input Btuh	AGA Output Btuh	Net I=B=R Water Ratings		Flue Outlet Dia. & No.		Common Vent Dia.	Chimney Diameter & Height
			Btuh**	SQ. FT.	8"	9"		
MAGB500	500,000	*410,000	356,500	2,377	2		10"	12" X 15'
MAGB600	600,000	480,000	423,000	2,817		2	12"	14" X 15'
MAGB750	750,000	*615,000	533,000	3,553	3		12"	14" X 20'
MAGB900	900,000	720,000	634,000	4,226		3	14"	16" X 20'
MAGB1000	1,000,000	*820,000	713,000	4,753	4		14"	16" X 20'
MAGB1200	1,200,000	960,000	845,000	5,635		4	16"	18" X 20'
MAGB1500	1,500,000	1,200,000	1,057,000	7,043		5	16"	20" X 20'
MAGB1800	1,800,000	1,440,000	1,268,000	8,452		6	18"	20" X 30'
MAGB2100	2,100,000	1,680,000	1,479,000	9,861		7	20"	22" X 30'
MAGB2400	2,400,000	1,920,000	1,690,000	11,289		8	22"	24" X 30'

* DOE HEATING CAPACITY

**For elevations above 2000 feet ratings should be reduced at a rate of 4% for each 1000 feet above sea level.

**For equivalent square feet of radiation, divide I=B=R output by 150.

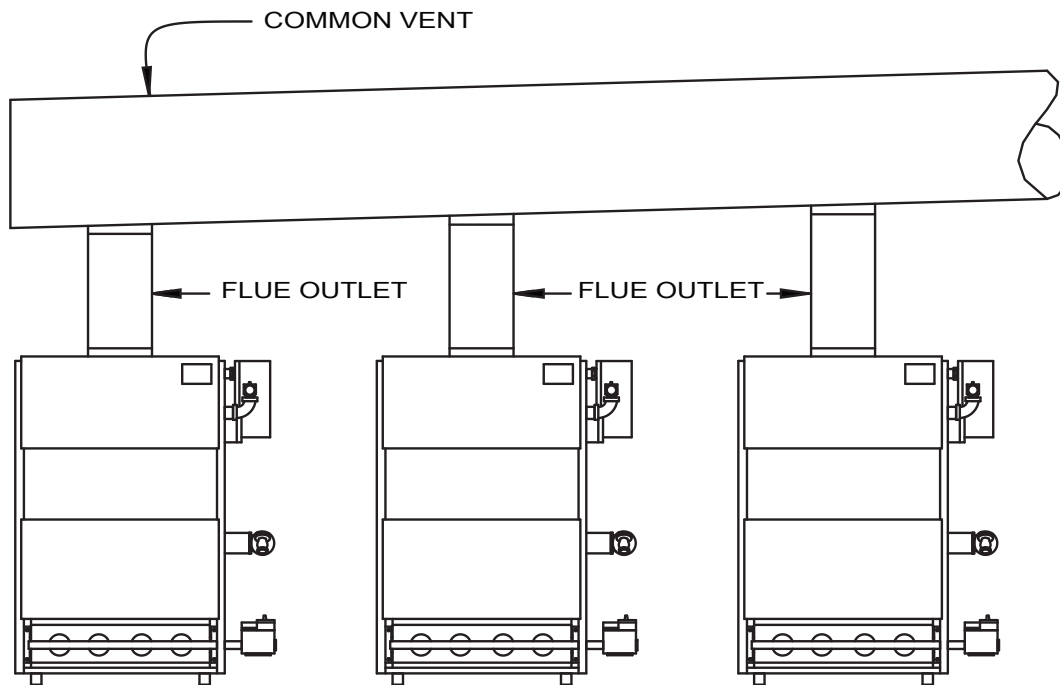

TYPICAL LAYOUTS FOR GAS FIRED SYSTEMS

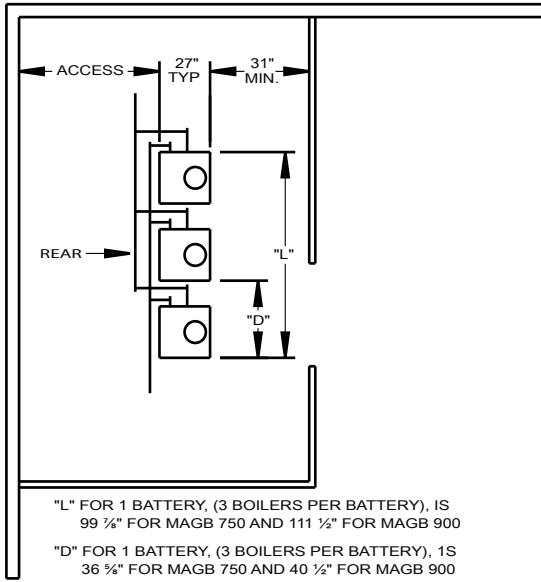

"L" FOR 1 BATTERY, (3 BOILERS PER BATTERY), IS 99 ¼" FOR MAGB 750 AND 111 ½" FOR MAGB 900

"D" FOR 1 BATTERY, (3 BOILERS PER BATTERY), IS 36 ¾" FOR MAGB 750 AND 40 ½" FOR MAGB 900

"L" FOR 1 BATTERY, (2 BOILERS PER BATTERY), IS 63 ¼" FOR MAGB 500 AND 71" FOR MAGB 600

"D" FOR 1 BATTERY, (2 BOILERS PER BATTERY), IS 36 ¾" FOR MAGB 500 AND 40 ½" FOR MAGB 600

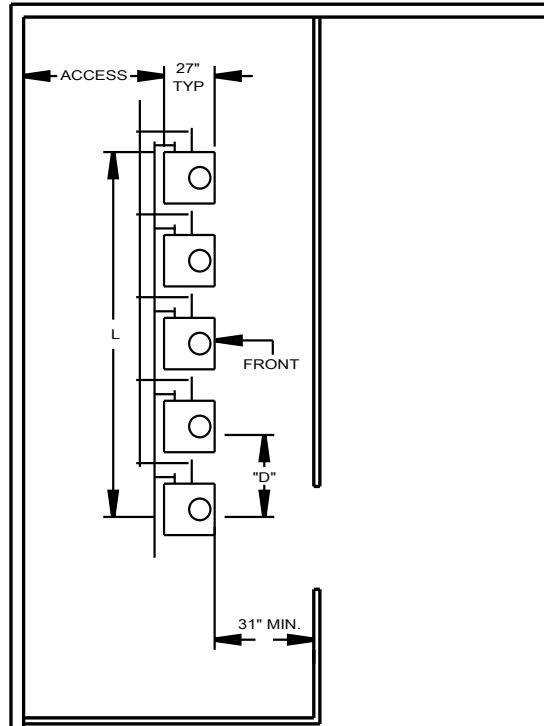

"L" FOR 1 BATTERY, (5 BOILERS PER BATTERY) IS 192 ½" FOR MAGB 1500

"D" FOR 1 BATTERY, (5 BOILERS PER BATTERY) IS 40 ½" FOR MAGB 1500

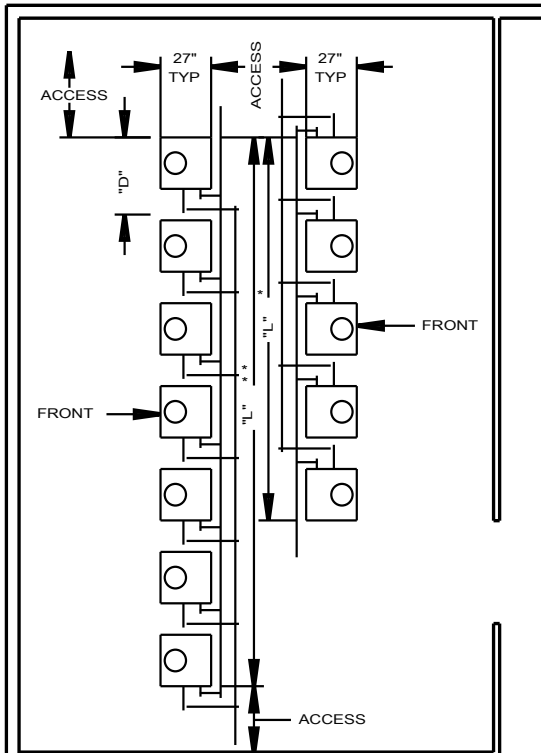

* "L" FOR 1 BATTERY WITH 5 BOILERS IS 192 ½" FOR MAGB 1500

** "L" FOR 1 BATTERY WITH 7 BOILERS IS 273 ½" FOR MAGB 2100

"D" FOR 1 BATTERY WITH 7 BOILERS IS 40 ½".

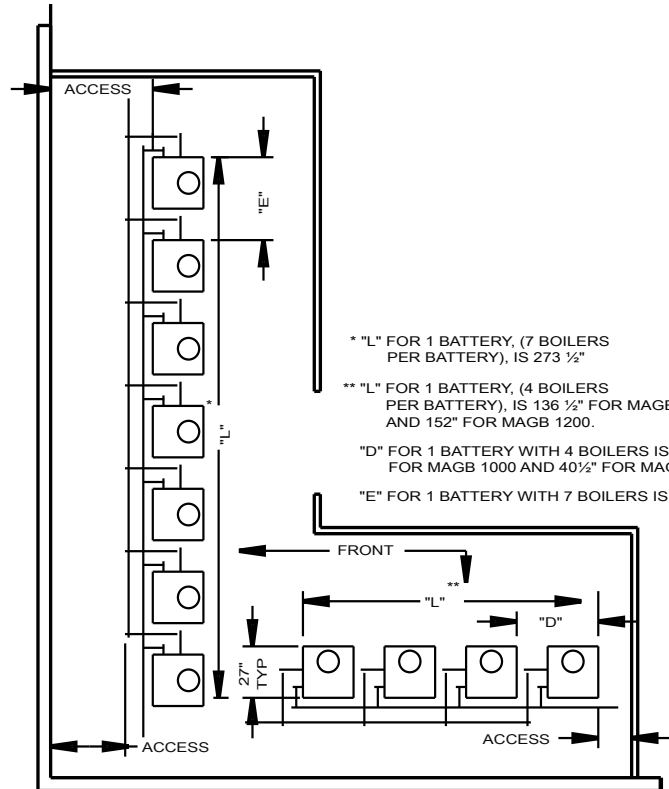

* "L" FOR 1 BATTERY, (7 BOILERS PER BATTERY), IS 273 ½"

** "L" FOR 1 BATTERY, (4 BOILERS PER BATTERY), IS 136 ½" FOR MAGB 1000 AND 152" FOR MAGB 1200.

"D" FOR 1 BATTERY WITH 4 BOILERS IS 36 ¾" FOR MAGB 1000 AND 40 ½" FOR MAGB 1200.

"E" FOR 1 BATTERY WITH 7 BOILERS IS 40 ½".

NOTE: FOR ACCESS DIMENSION, REFER TO LOCAL CODES OR MAINTAIN NO LESS THAN 24".

SUPPLY AND RETURN PIPING

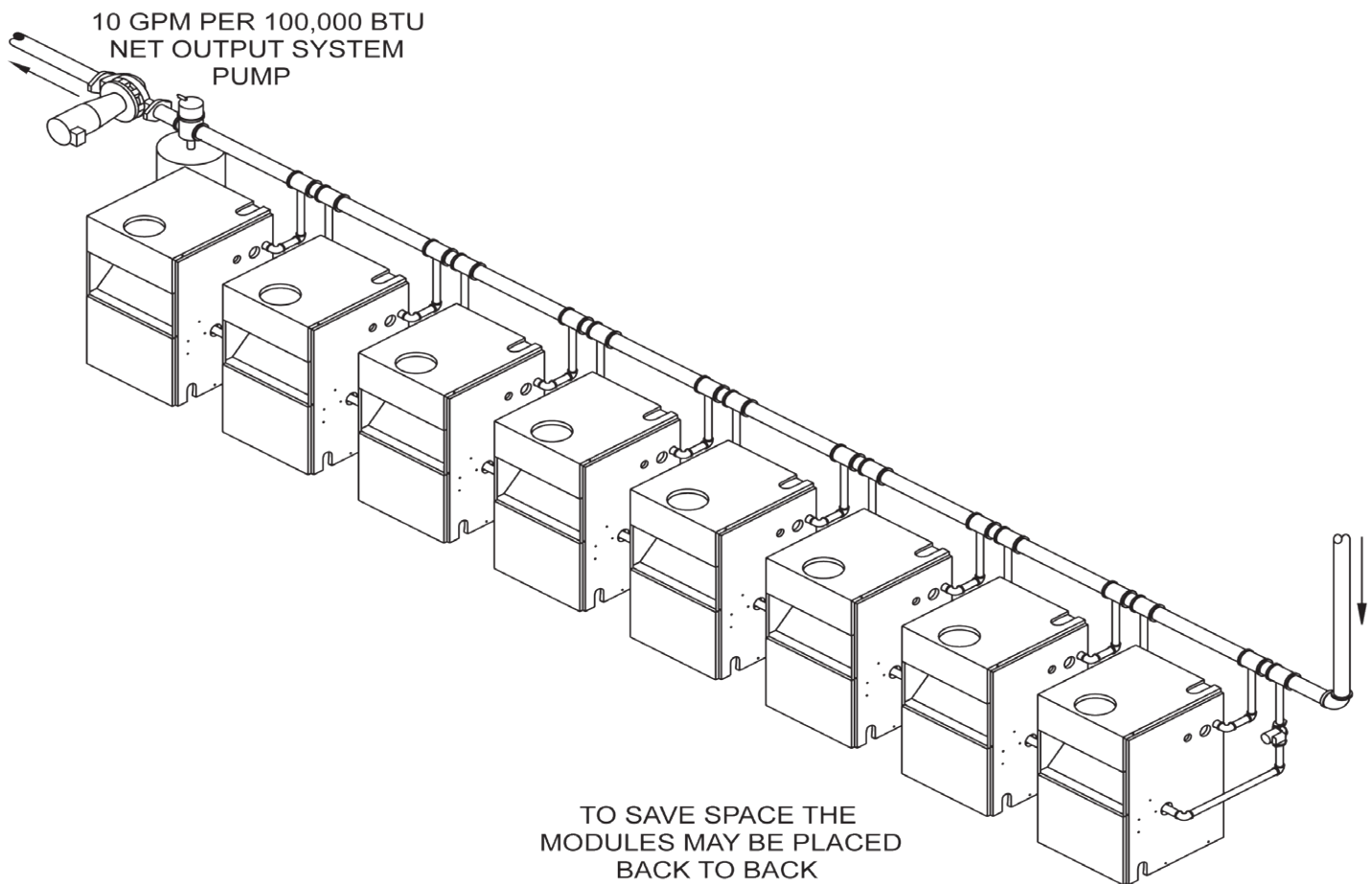

INSTALLATION PROCEDURE

WARNING

- 1. Keep boiler area clear and free from combustible materials, gasoline and other flammable vapors and liquids.
- 2. DO NOT obstruct air openings to the boiler room.
- 3. Modification, substitution or elimination of factory equipped, supplied or specified components may result in property damage, personal injury or the loss of life.
- 4. When this product is installed in the Commonwealth of Massachusetts the installation must be performed by a Licensed Plumber or Licensed Gas Fitter.

Improper installation, adjustment, alteration, service or maintenance can cause injury or property damage.

1. The installation must conform to the requirements of the authority having jurisdiction or, in the absence of such requirements, to the latest revision of the National Fuel Gas Code, ANSI Z223. (Available from the American Gas Association, 8501 E. Pleasant Valley Road, Cleveland, Ohio 44134). Reference should also be made to local gas utility regulations and other codes in effect in the area in which the installation is to be made.
2. Where required by the authority having jurisdiction, the installation must conform to American Society of Mechanical Engineers Safety Code for Controls and Safety Devices For Automatically Fired Boilers, No.CSD-1.
3. This boiler series is classified as a Category 1 and the vent installation shall be in accordance with the latest revision of the National Fuel Gas Code noted above or applicable provisions of the local building codes.
4. This boiler has met safe lighting and other performance criteria with the gas manifold and control assembly on the boiler per the latest revision of ANSI Z21.13.
5. The boiler shall be installed such that the gas ignition system components are protected from water (dripping, spraying, rain, etc.) during appliance operation and service, (circulator

INSTALLATION PROCEDURE

replacement, condensate trap, control replacement, etc.).

6. LOCATE BOILER on level, solid base as near the chimney as possible and centrally located with respect to the heat distribution system as practical.
7. Allow 24 inches at the front and right side for servicing and cleaning.
8. When installed in a utility room, the door should be wide enough to allow the largest boiler part to enter, or to permit replacement of another appliance such as a water heater.
9. The MEA number for this boiler series is 19-79-E.

FOR INSTALLATION ON NON-COMBUSTIBLE FLOORS ONLY

*. The boiler must not be installed on carpeting. Minimum clearances to combustible construction are:

TOP	18 IN.
FRONT	ALCOVE
FLUE CONNECTOR	6 IN.
REAR.....	4 IN.
CONTROL SIDE.....	9 IN.
OTHER SIDE	3 IN.

NOTE: Greater clearances for access should supersede fire protection clearances.

* For installation on combustible flooring special base part no. 325-2-8.00 must be used.

VENTILATION AND COMBUSTION AIR

WARNING



Air openings to combustion area must not be obstructed. By following the chart below, adequate combustion air can be maintained.

COMBUSTION AIR REQUIREMENTS (Minimum Opening In Square Inches)					
Model Number	Number Of Modules	*UNCONFINED AREA		**CONFINED AREA OUTSIDE COMBUSTION AIR	
		Outside Combustion Air 1 Sq. In./4000 Btuh (See Figure #2)	Outside Combustion Air 1 Sq. In./1000 Btuh (See Figure #1)	Vert. Ducts 1 Sq. In. /4000 Btuh	Horz. Ducts 1 Sq. In. /2000 Btuh
		MAGB500	2	125	500
MAGB600	2	150	600	150	300
MAGB750	3	188	750	188	375
MAGB900	3	225	900	225	450
MAGB1000	4	250	1000	250	500
MAGB1200	4	300	1200	300	600
MAGB1500	5	375	1500	375	750
MAGB1800	6	450	1800	450	900
MAGB2100	7	525	2100	525	1050
MAGB2400	8	600	2400	600	1200

* **Unconfined Area:** A space whose volume is not less than 50 cubic feet per 1000 Btu per hour of all appliances installed in that space (Cubic feet of space = height x width x length).

** **Confined Area:** A space whose volume is less than 50 cubic feet per 1000 Btu per hour of all appliances installed in that space (Cubic feet of space = height x width x length).

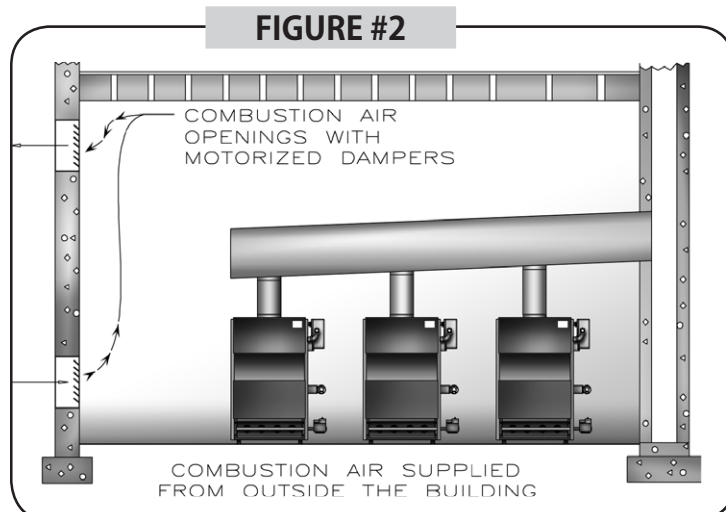
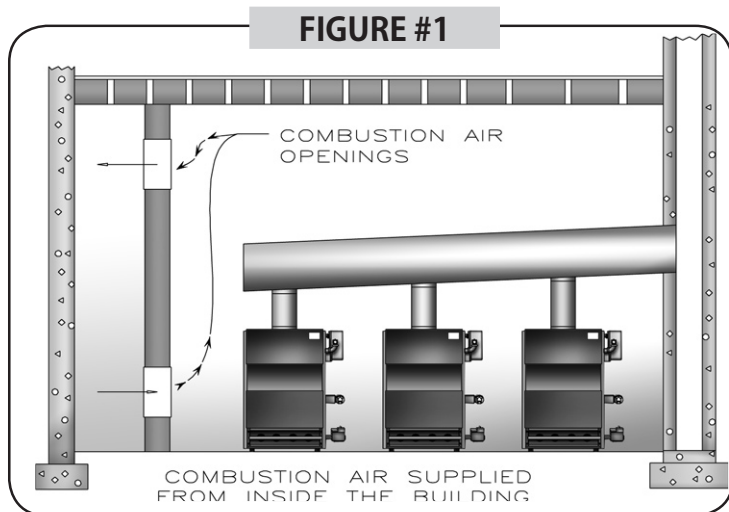

1. Ventilation of the boiler room must be adequate to provide sufficient air to properly support combustion per the latest revision of the National Fuel Gas Code, ANSI Z223.1.
2. When a boiler is located in an unconfined space in a building or conventional construction frame, masonry or metal building, infiltration normally is adequate to provide air for combustion and ventilation. However, if the equipment is located in a building of tight construction (See the National Fuel Gas Code, ANSI Z223.1) the boiler area should be considered as a confined space. If there is any doubt, install air supply provisions in accordance with the latest revision of the National Fuel Gas Code.
3. When a boiler is installed in an unconfined space, in a building of tight construction, air for combustion and ventilation must be obtained from outdoors or from spaces freely communicating with the outdoors. A permanent opening or openings having a total free area of not less than 1 square inch per 5,000 BTU per hour of total input rating of all appliances shall be provided. Ducts may be used to convey makeup air from the outdoors and shall have the same cross-sectional area of the openings to which they are connected.
4. When air for combustion and ventilation is from inside buildings, the confined space shall be provided with two permanent openings, one starting 12 inches from the top and one 12 inches from the bottom of the enclosed space. Each opening shall have a minimum free area of 1 square inch per one thousand (1000) BTU per hour of the total input rating of all appliances in the enclosed space, but must not be less than one hundred (100) square inches. These openings must freely communicate directly with other spaces of sufficient volume so that the combined volume of all spaces meets the criteria for an unconfined space. See **figure #1**.
5. When the boiler is installed in a confined space and all air is provided from the outdoors the confined space shall be provided with one or two permanent openings according to methods A or B. When ducts are used, they shall be of the same cross sectional area as the free area of the area of the openings to which they connect. The minimum dimension of rectangular air ducts shall be not less than 3 x 3 inches or 9 square inches.
 - A. When installing two openings, one must commence within 12 inches from the top and the other within 12 inches from the bottom of the enclosure. The openings shall communicate directly, or by ducts, with the outdoors or spaces (crawl or attic) that freely communicate with the outdoors. One of the following methods must be used to provide adequate air for ventilation and combustion.
 - I. When directly communicating with the outdoors, each opening shall have a minimum free area of 1 square inch per 4,000 BTU per hour of total input rating of all equipment in the enclosure. See figure #2.
 - II. When communicating with the outdoors by means of vertical ducts, each opening shall have a minimum free area 1 square inch per 4,000 BTU per hour of total input rating of all appliances in the enclosed space.
 - III. If horizontal ducts are used, each opening and duct shall have a minimum free area 1 square inch per 2,000 BTU per hour of total input rating of all appliances in the enclosed space.
 - B. One permanent opening, commencing within 12 inches of the top of the enclosure, shall be permitted where the equipment has clearances of at least 1 inch from the sides, 1 inch from the back, and 6 inches from the front of the boiler. The opening shall directly communicate with the outdoors or shall communicate through a vertical or horizontal duct to the outdoors or spaces (crawl or attic) that freely communicate with the outdoors. The openings must have a minimum free area of 1 square inch per 3000 Btu per hour of the total input rating of all equipment located in the enclosure. The free area must be no less than

VENTILATION & COMBUSTION CONTINUED

the sum of the areas of all vent connectors in the confined space.

6. In calculating free area using louvers, grilles or screens for the above, consideration shall be given to their blocking effect. Screens used shall not be smaller than ¼ inch mesh. If the free area through a design of louver or grill is known, it should be used in calculating the size opening required to provide the free area specified. If the design and free area is not known, it may

be assumed that wood louvers will have 20-25% free area and metal louvers and grilles will have 60-75% free area. Louvers and grilles should be fixed in the open position or interlocked with the boiler so they are opened automatically during the boiler operation.

VENT INSTALLATION

WARNING



This boiler is to be vented by natural draft and shall not be connected to the mechanical draft system operating under positive pressure.

1. The vent pipe must slope upward from the boiler not less than ¼ inch for every 1 foot to the vent terminal.
2. Horizontal portions of the venting system shall be supported rigidly every 5 feet and at the elbows. No portion of the vent pipe should have any dips or sags.
3. This boiler series is classified as a Category 1 and the vent installation shall be in accordance with the National Fuel Gas Code noted above or applicable provisions of the local building codes.
4. Inspect chimney to make certain it is constructed according to NFPA 211. The vent or vent collector shall be Type B or metal pipe having resistance to heat and corrosion not less than that of galvanized sheet steel or aluminum not less than 0.016 inch thick (No. 28 Ga).
5. Connect flue pipe from draft hood to chimney. Bolt or screw joints together to avoid sags. Flue pipe should not extend beyond inside wall of chimney. Do not install manual damper in flue pipe or reduce size of flue outlet except as provided by the latest revision of ANSI Z223.1. Protect combustible ceiling and walls near flue pipe with fireproof insulation. Where two or more appliances vent into a common flue, the area of the common flue must be at least equal to the area of the largest flue plus 50 percent of the area of each additional flue.

INSTALLATION FOR OPTIONAL VENT DAMPER

NOTE: Refer to Figure #3 for steps 1 - 7.

1. Place Vent Damper on or as close to vent outlet of boiler as possible.
2. Remove Vent Damper Motor cover.
3. Feed Damper and Damper wire harness connectors through bracket hole on Damper Motor frame.
4. Tighten locknut onto Damper wire harness connector.
5. Plug Damper connector into socket on Damper Motor frame.
6. Replace Damper Motor cover.
7. Wire Damper in accordance with **figure #3**.

INSTRUCTIONS

1. Ensure that only the boiler is serviced by the Vent Damper. See **Figure #4**.
2. Clearance of not less than 6 inches between Vent Damper and combustible material must be maintained. Additional clearance should be allowed for service of Vent Damper.
3. Vent Damper must be in the open position when appliance main burners are operating.
4. The Vent Damper position indicator must be in a visible location following installation.
5. The thermostat's heat anticipator must be adjusted to match the total current draw of all controls associated with the boiler during a heating cycle.

VENT INSTALLATION

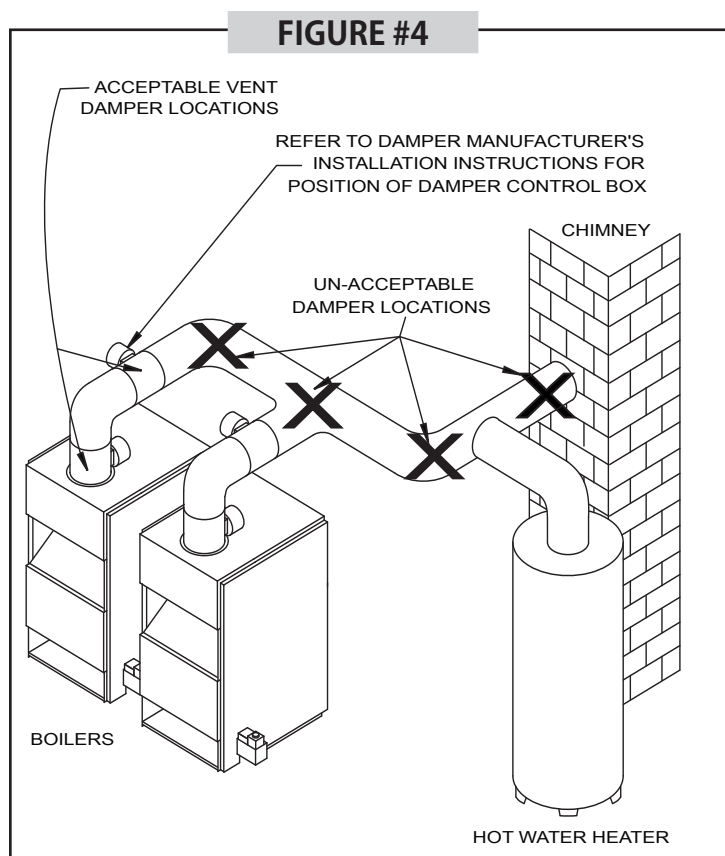
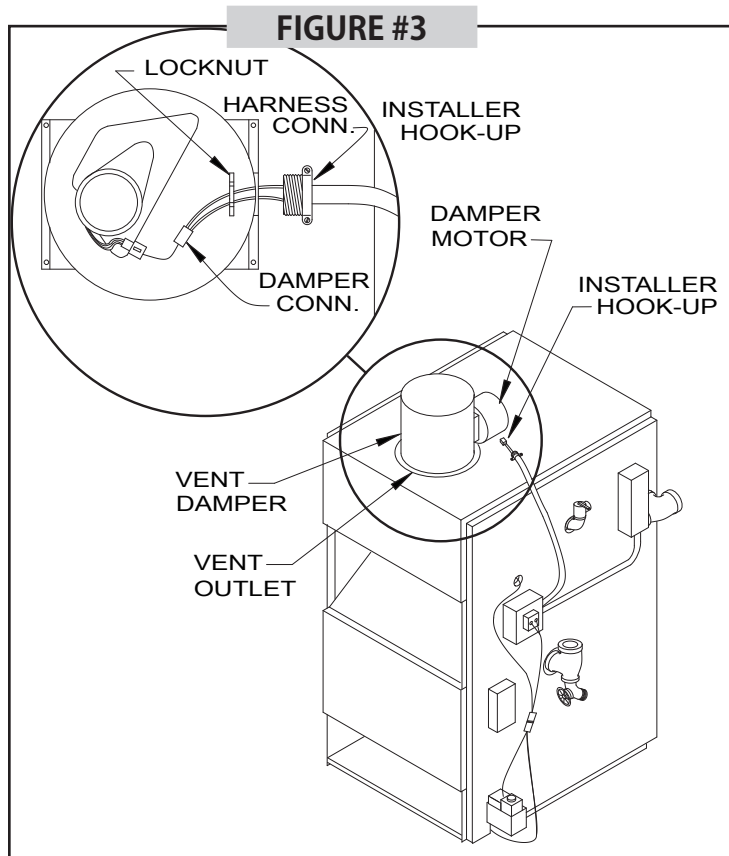

VENT SYSTEM MODIFICATION

When an existing boiler is removed from a common venting system, the common venting system is likely to be too large for the proper venting of the appliances remained connected to it. If this situation occurs, the following test procedure must be followed:

REMOVAL OF BOILER FROM VENTING SYSTEM

At the time of removal of an existing boiler, the following steps shall be followed with each appliance remaining connected to the common venting system placed in operation, while the other appliances remaining connected to the common venting system are not in operation.

1. Seal an unused opening in the common venting system.
2. Visually inspect the venting system for proper size and horizontal pitch and determine there is no blockage or restriction, leakage, corrosion and other deficiencies which could cause an unsafe condition.
3. Insofar as is practical, close all building doors and windows and all doors between the space in which the appliances remaining connected to the common venting system are located and other spaces of the building. Turn on clothes dryers and any other ap-

pliance not connected to the common venting system. Turn on any exhaust fans, such as range hoods and bathroom exhausts, so they operate at maximum speed. Do not operate a summer exhaust fan. Close fireplace dampers.

4. Place in operation the appliance being inspected. Follow the lighting instructions. Adjust thermostat so appliance will operate continuously.
5. Test for spillage at the draft hood relief opening after 5 minutes of main burner operation. Use the flame of a match or candle, or smoke from a cigarette, cigar or pipe.
6. After it has been determined that each appliance remaining connected to a common venting system properly vents when tested as outlined above, return doors, windows, exhaust fans, fireplace dampers and any other gas burning appliances to their previous condition of use.
7. Any improper operation of the common venting system should be corrected so the installation conforms with the latest revision of the National Fuel Gas Code, ANSI Z223.1. When re-sizing any portion of the common venting system, the common venting system should be re-sized to approach the minimum size as determined using the appropriate tables in the latest revision of the National Fuel Gas Code, ANSI Z223.

CONNECTING BOILERS WITH REFRIGERATION SYSTEMS

1. Connect supply and return piping as suggested in **figure 5**, when the boiler is used in connection with refrigerated systems.
2. The chilled medium **MUST BE PIPED IN PARALLEL** with the boiler.
3. Use appropriate valves to prevent the chilled medium from entering the heating boiler.
 - A. During heating cycle open valves A and B, close valves C and D.
 - B. During cooling cycle, open valves C and D, close valves A and B.
 - C. Maintain a minimum clearance of one inch to hot water
4. For further information refer to the I=B=R Installation and Piping Guide.

pipes.

- D. When the boiler is connected to heating coils located in air handling units where they may be exposed to refrigerated air circulation, the boiler piping system **MUST BE** supplied with flow control valves or other automatic means to prevent gravity circulation of the boiler water during the cooling cycle.

4. For further information refer to the I=B=R Installation and Piping Guide.

FIGURE #5

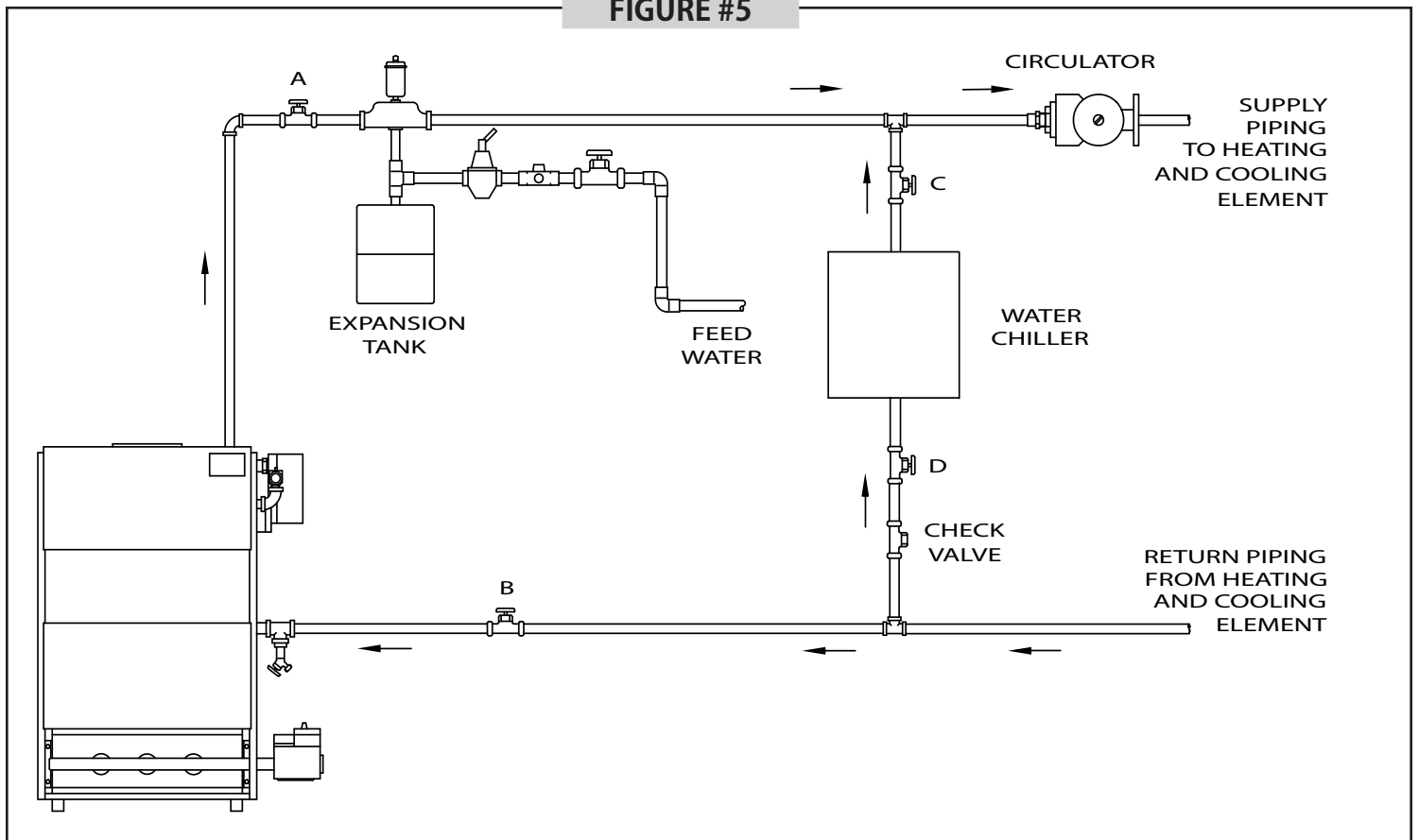

CONNECTING GAS SERVICE

1. Connect gas service from meter to control assembly in accordance with ANSI Z223.1 and local codes or utility. A ground joint union should be installed for easy removal of gas control for servicing. A drip leg or trap must be installed at the bottom of a vertical section of piping at the inlet to the boiler. A pipe compound resistant to the action of liquefied petroleum gases must be used on all threaded pipe connections. Check with the local utility for location of manual shutoff valve if required. See **figure #6**.
2. The gas line should be of adequate size to prevent undue pressure drop and never smaller than the pipe size of the main gas control valve. See chart below.

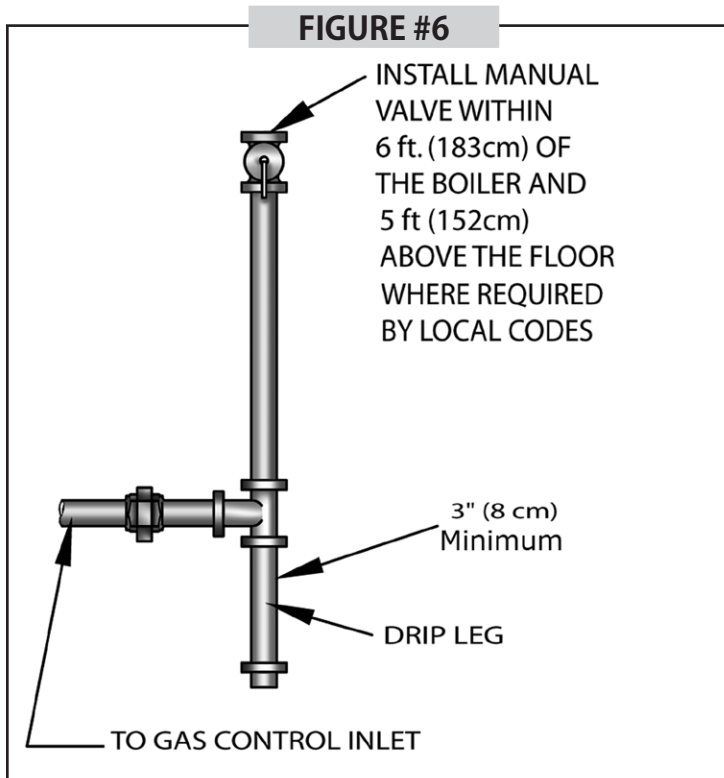

3. Check all connections using a commercially available soap solution made specifically for leak detection.



WARNING

DO NOT USE AN OPEN FLAME!

4. Disconnect the boiler from the gas supply piping system during any pressure testing of the gas piping. After reconnecting, leak test the gas connection and boiler piping before placing the boiler back into operation.
5. See **figure #7** for a typical gas line installation, and the table for pipe sizes.

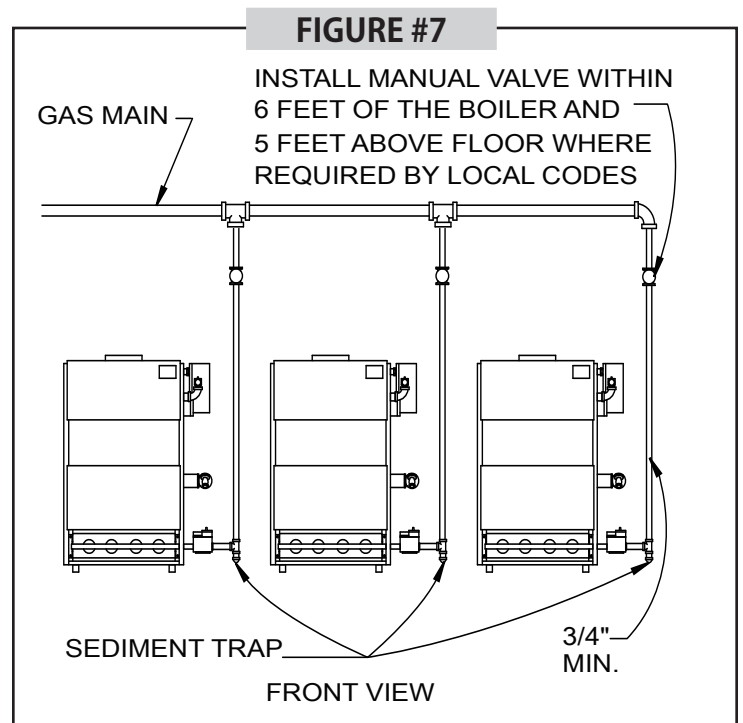

PRESSURE	GAS	
	NATURAL	PROPANE
MIN. SUPPLY	5" w.c.	11" w.c.
MAX. SUPPLY	14" w.c.	14" w.c.
MANIFOLD	3.5" w.c.	10.5" w.c.

CONNECTING GAS SERVICE

MAGB PIPE SIZES IN INCHES FOR NATURAL GAS MAIN								
Model Number	Run Length in Feet							
	20'	30'	40'	50'	60'	80'	100'	125'
500	1.25"	1.25"	1.50"	1.50"	2.00"	2.00"	2.00"	2.00"
600	1.25"	1.25"	1.50"	1.50"	2.00"	2.00"	2.00"	2.00"
750	1.25"	1.50"	1.50"	2.00"	2.00"	2.00"	2.00"	2.00"
900	1.50"	2.00"	2.00"	2.00"	2.00"	2.00"	2.50"	2.50"
1000	1.50"	2.00"	2.00"	2.00"	2.00"	2.50"	2.50"	2.50"
1200	2.00"	2.00"	2.00"	2.00"	2.50"	2.50"	2.50"	2.50"
1500	2.00"	2.00"	2.50"	2.50"	2.50"	2.50"	3.00"	3.00"
1800	2.00"	2.00"	2.50"	2.50"	2.50"	3.00"	3.00"	3.00"
2100	2.50"	2.50"	2.50"	3.00"	3.00"	3.00"	3.00"	4.00"
2400	2.50"	2.50"	3.00"	3.00"	3.00"	3.00"	3.00"	4.00"

ELECTRICAL WIRING

WARNING



1. When an external electrical source is utilized, the boiler, when installed **MUST BE** electrically grounded in accordance with these requirements.
2. Install a fused disconnect switch between boiler and electrical panel at a convenient location.
3. The MAGB series requires 120 Volts to operate.

Electrical wiring must conform with the National Electrical Code, ANSI/NFPA No. 70 when installed in the United States, the CSA C22.1 Canadian Electrical Code, Part 1, when installed in Canada, and/or the local authority having jurisdiction.

THERMOSTAT INSTALLATION

1. Thermostat should be installed on an inside wall about four feet above the floor.
2. Check thermostat operation by raising and lowering thermostat setting as required to start and stop the burners.
3. Instructions for the final adjustment of the thermostat are packaged with the thermostat (adjusting heating anticipator, calibration, etc.)

THINGS TO AVOID WHEN LOCATING THERMOSTATS	
DEAD SPOTS:	
Corners and alcoves	Behind doors
COLD SPOTS:	
Concealed pipes or ducts	Concealed pipes
	Fireplace or chimney
Stairwells - drafts	TV sets
	Radios
Unheated rooms on other side of wall	Lamps
	Direct sunlight
Outside wall	Kitchens

ELECTRICAL WIRING

CAUTION



Label all wires prior to disconnection when servicing controls. Wiring errors can cause improper and dangerous operation. Verify proper operation after service.

24 VOLT GAS CONTROL WIRING WITH LIMIT CONTROL

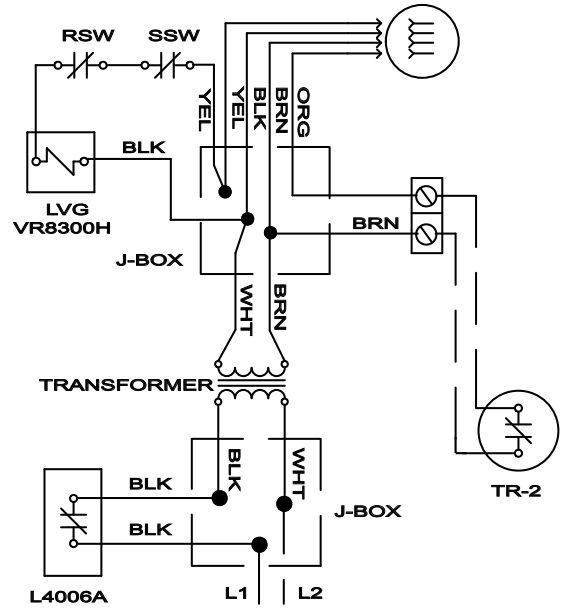
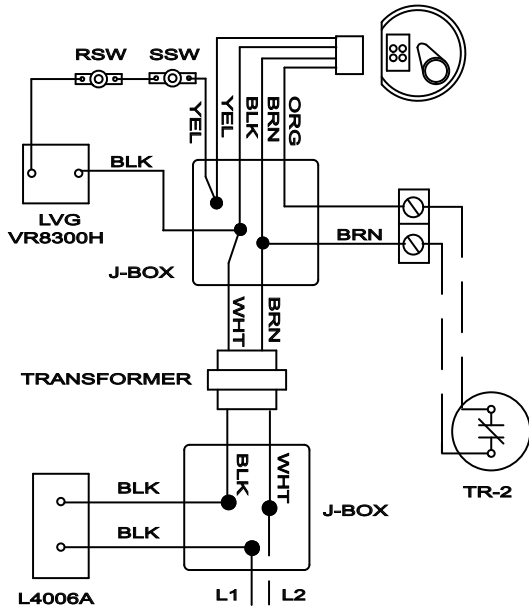

HOT WATER CONTROL AND INTERMITTENT IGNITION WIRING WITH LIMIT CONTROL

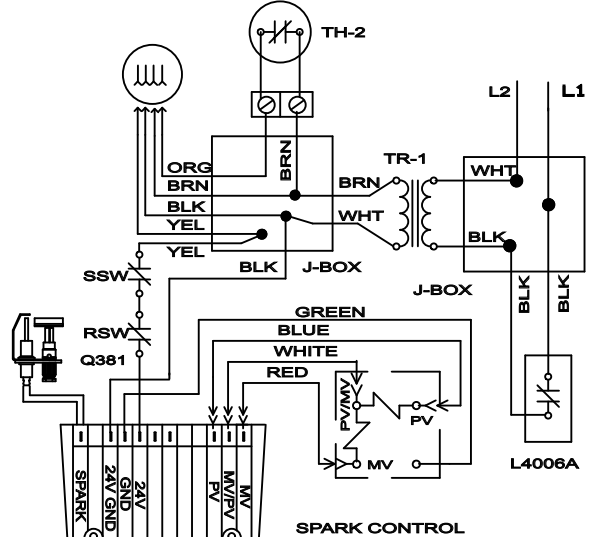
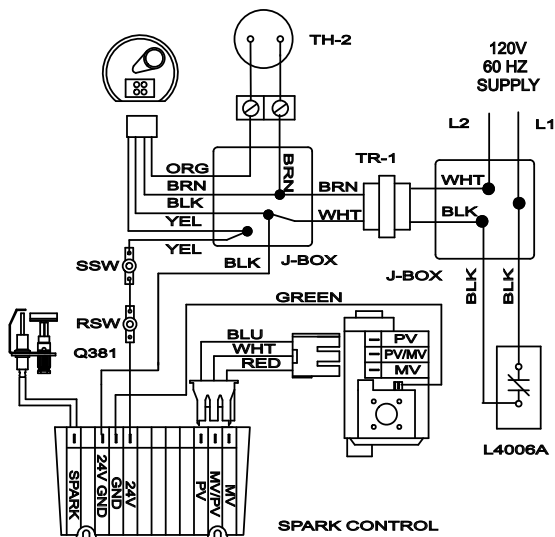

TH-1	THERMOSTAT (MILLIVOLT)	1K	RELAY COIL
TH-2	THERMOSTAT (24V)	1K1	RELAY CONTACTS
TH-3	THERMOSTAT (LINE VOLTAGE)	1K2	RELAY CONTACTS
TR-1	TRANSFORMER (120V/24V 40VA)	LS	LIMIT SWITCH
TR-2	TRANSFORMER (120V/24V 50VA)	MS	MANUAL SWITCH
MGV	MILLIVOLT GAS VALVE	CIR	CIRCULATOR
LGV	24V GAS VALVE	ECO	ENERGY CUT OFF
LGV-1	24V GAS VALVE	LWCO	LOW WATER CUT OFF
PS	PRESSURE SWITCH	ESF	ELECTRIC WATER FEEDER
MR-PS	MANUAL RESET PRESSURE SWITCH	PG	POWER GENERATOR
SD	STACK DAMPER	PSC	PILOT SAFETY COIL
	CONTROL TERMINAL		WIRE CONNECTION

NOT ALL COMPONENTS LISTED ARE USED IN ALL CONTROLS SYSTEMS.

LINE VOLTAGE BY FACTORY



LOW VOLTAGE BY FACTORY



LINE VOLTAGE BY INSTALLER



LOW VOLTAGE BY FACTORY



NOTES:

- SWITCHES ARE SHOWN IN POSITION TAKEN DURING THE HEATING CYCLE.
- IF ANY OF THE ORIGINAL WIRING SUPPLIED WITH THE BOILER IS REPLACED, IT MUST BE REPLACED WITH LIKE WIRE SIZE AND TYPE OF INSULATION OR EQUIVALENT.

LIGHTING INSTRUCTIONS

WARNING



If you do not follow these instructions exactly, a fire or explosion may result causing property damage, personal injury or loss of life.

Before any procedures are attempted on this appliance, it is necessary to determine if the ignition system is electric or standing pilot. If you are uncertain, contact the manufacturer before proceeding.

CAUTION



Before lighting any type of pilot burner (standing or intermittent), make certain the hot water boiler and system are full of water to minimum pressure of 12 lbs. per square inch in the system, and also make certain that the system is vented of air. Set the operating control of thermostat to a "below" normal setting. Refer to the following appropriate lighting instruction.

DANGER





1. This appliance is equipped with an ignition device which automatically lights the pilot. Do not try to light the pilot by hand.
2. BEFORE OPERATING smell all around the appliance area for gas. Be sure to smell next to the floor because some gas is heavier than air and will settle on the floor.

WHAT TO DO IF YOU SMELL GAS

- Do not try to light any appliance.
- Do not touch any electrical switch; do not use any phone in your building.

- Immediately call your gas supplier from a neighbor's phone. Follow the gas supplier's instructions.
- If you cannot reach your gas supplier, call the fire department.
3. Use only your hand to move the gas control knob. Never use tools. If the knob will not move by hand, don't try to repair it, call a qualified service technician. Force or attempted repair may result in a fire or explosion.
4. Do not use this appliance if any part has been under water. Immediately call a qualified service technician to inspect the appliance and to replace any part of the control system and any gas control which has been under water.

LIGHTING INSTRUCTIONS FOR INTERMITTENT PILOT SYSTEMS

1. STOP! Read the safety information above on this label.
2. Set thermostat to lowest setting.
3. Turn off all electric power to the appliance.
4. This appliance is equipped with an ignition device which automatically lights the burner. DO NOT try to light the burner by hand.
5. Remove the front jacket panel.
6. Turn the gas control knob clockwise  to "OFF". (See **Figure #8**)
7. Wait five (5) minutes to clear out any gas. Then smell for gas, including near the floor. If you smell gas, STOP! Follow "What To Do If You Smell Gas" section. If you don't smell gas, go on to the next step.
8. Turn the gas control knob counterclockwise  to "ON".

9. Replace front jacket panel.
10. Turn on all electrical power to the appliance.
11. Set the thermostat to desired setting.
12. If the appliance will not operate, follow the instructions "To Turn Off Gas To Appliance" and call your service technician or gas supplier.

TO TURN OFF GAS TO APPLIANCE

13. Set the thermostat to lowest setting.
14. Turn off all electric power to the appliance if service is to be preformed.
15. Remove the front jacket panel.
16. Turn gas control knob clockwise  to "OFF".
17. Replace the front jacket panel.

LIGHTING INSTRUCTIONS

LIGHTING INSTRUCTIONS FOR CONTINUOUS PILOT

18. STOP! Read the safety information at the beginning of these instructions.
19. Set the thermostat to the lowest setting.
20. Turn off all electric power to the appliance.
21. Remove access panel and burner door.
22. Turn gas control knob clockwise ↻ to "OFF" See **Figure #9**. NOTE #1: Some gas control knobs cannot be turned from "PILOT" to "OFF" unless knob is pushed in slightly. DO NOT FORCE.
23. Wait (5) minutes to clear out any gas. If you then smell gas, STOP! Follow "What To Do If You Smell Gas", section. If you don't smell gas, go to the next step.
24. Find pilot. Follow metal tube from gas control. Depending on the model of the boiler, pilot is either mounted on the base or on one of the burner tubes.
25. Turn gas control knob counterclockwise ↻ to "PILOT".
26. Push in gas control knob or reset button if so equipped, all the way in and hold. Immediately light the pilot with a match. Continue to hold the gas control knob or reset button in for about 1 minute after the pilot is lit. Release knob or button, and it will pop up back up. Pilot should remain lit. If it goes out, repeat steps 5 through 9.
 - If knob or button does not pop up when released, stop and immediately call a qualified service technician or your gas supplier.
 - If the pilot will not stay lit after several tries, turn the gas control knob clockwise ↻ to "OFF". (See note #1), and call a qualified service technician or your gas supplier.
27. Replace burner door.

FIGURE #9

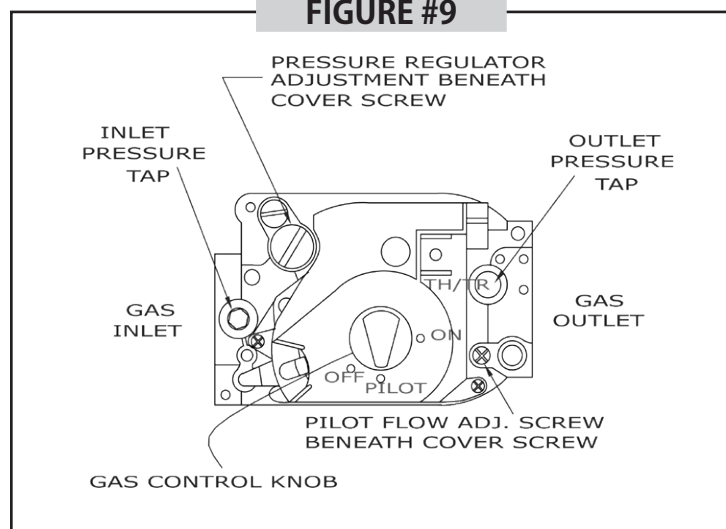

28. Turn gas control knob counterclockwise ↻ to "ON".
 29. Replace access panel.
 30. Turn on all electric power to the appliance.
 31. Set thermostat to desired setting.
- ### TO TURN OFF GAS TO APPLIANCE
32. Set the thermostat to lowest setting.
 33. Turn off all electric power to the appliance if service is to be performed.
 34. Push in gas control knob slightly and turn clockwise ↻ to "OFF", DO NOT FORCE.
 35. Call a qualified service technician.

NORMAL SEQUENCE OF OPERATION

For a single module the thermostat will actuate, completing the circuit to the aquastat. The completed circuit to the aquastat will first activate the circulator and damper. When the damper is fully open it will complete the circuit to the ignition system and ignition will take place.

In the event the boiler water temperature exceeds the high limit setting on the boiler mounted aquastat, power will be interrupted between the aquastat and the ignition system. The power will remain off until the boiler water temperature drops below the high limit setting. The circulator will continue to operate under this condition

until the thermostat is satisfied.

In the event the flow of combustion products through the boiler venting system becomes blocked, the blocked vent safety switch will shut the main burner gas off or, if the boiler flueway becomes blocked, the flame rollout safety switch will shut the main burner gas off. See **Figure #11**. If either of these conditions occur, do not attempt to place the boiler back into operation. Contact a qualified service agency.

GENERAL INSTRUCTIONS

Before seasonal start-up, have a competent service agency check the boiler for soot and scale in the flues, clean the burners and check the gas input rate to maintain high operating efficiency.

CAUTION

Label all wires prior to disconnection when servicing controls. Wiring errors can cause improper and dangerous operation.

Verify proper operation after service.

The service agency or owner should make certain the system is filled with water to minimum pressure and open air vents, if used, to expel any air that may have accumulated in the system. Check the entire piping system and if any leaks appear, have them repaired.

Circulators must be checked and maintained. Refer to the circulator manufacturer's instructions.

The venting system should be inspected at the start of each heating season. Check the vent pipe from the boiler to the chimney for signs of deterioration by rust or sagging joints. Repair if necessary. Remove the vent pipe at the base of the chimney or flue and using a mirror, check vent for obstruction and make certain the vent is in good working order.

The boiler flue gas passageways may be inspected by a light and mirror. Remove the burner door, **figure #11** Place a trouble lamp in the flue collector through the draft relief opening. With the mirror positioned above the burners, the flue gas passageways can be checked for soot or scale.



The following procedure should be followed to clean the flue gas passageways:

1. Remove the burners from the combustion chamber by raising the burners up from the manifold orifices and pulling toward the front of the boiler. See **figure #11**.
2. Disconnect the vent pipe from the draft hood.
3. Remove the top jacket panel.
4. Remove the combination flue collector and draft hood from the boiler castings by loosening the nuts on the hold down bolts located on each side of the collector. See **figure #11**.
5. Place a sheet of heavy paper or similar material over the bottom of the base and brush down the flue passageways. The soot and scale will collect on the paper and is easily removed with the paper.

With the paper still in place in the base, clean the top of the boiler castings of the boiler putty or silicone used to seal between the castings and flue collector. Make certain that chips are not lodged in the flue passageways.

When the cleaning process is complete, restore the boiler components to their original position. Use IS-808 GE silicone, available from a distributor, to seal around the flue collector and boiler castings.

A visual check of the main burner and pilot flames should be made at the start of the heating season and again in mid-season. The main burner flame should have a well defined inner blue mantel with a lighter blue outer mantel. Check the burner throats and burner orifices for lint or dust obstruction. See **figures #12 and #13**.

The pilot flame should envelop $\frac{3}{8}$ to $\frac{1}{2}$ inch of the tip of the pilot thermocouple, ignition/sensing electrode or mercury sensor. See **figure #14**. To adjust the pilot flame, remove the pilot adjustment cover screw (**figures #8, & #9**), and turn the inner adjustment screw counterclockwise  to increase or clockwise  to decrease pilot flame. Be sure to replace cover screw after adjustment to prevent possible gas leakage.

The burners and pilot should be checked for signs of corrosion, rust or scale buildup. The area around the boiler must be kept clear and free of combustible materials, gasoline and other flammable vapors and liquids.

The free flow of combustion and ventilating air to the boiler and boiler room must not be restricted or blocked.

It is recommended that a qualified service agency be employed to make an annual inspection of the boiler and heating system. They are experienced in making the inspections outlined above, and, in the event repairs or corrections are necessary, trained technicians can make the proper changes for safe operation of the boiler.

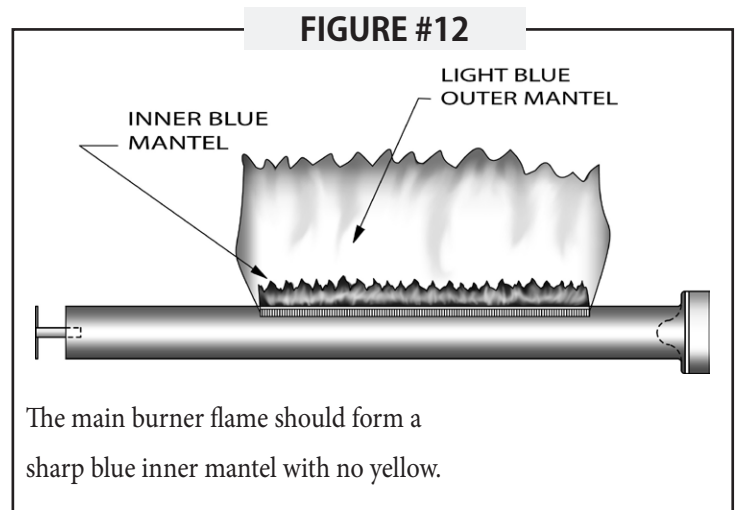

GENERAL INSTRUCTIONS

FIGURE #11

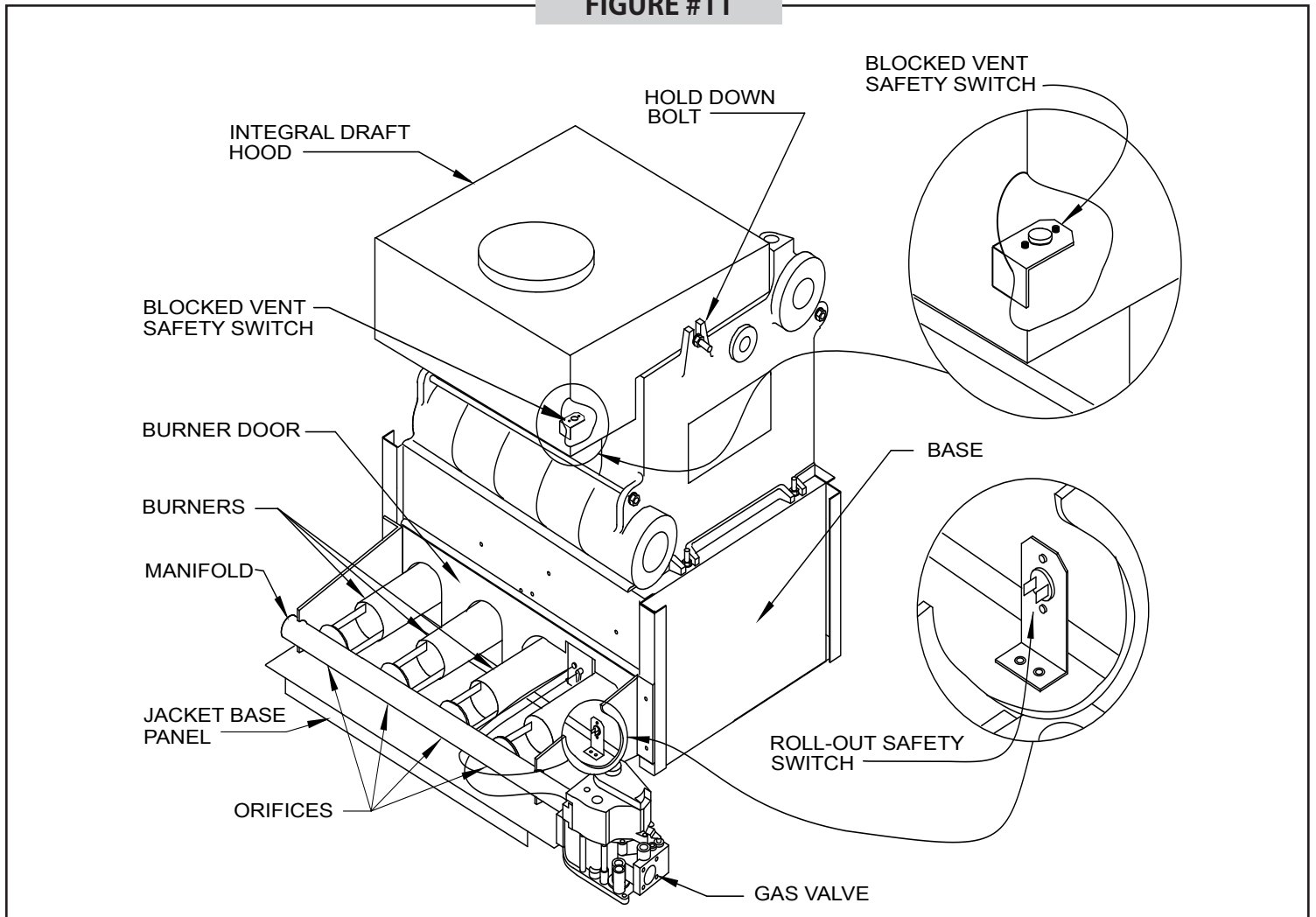

FIGURE #13

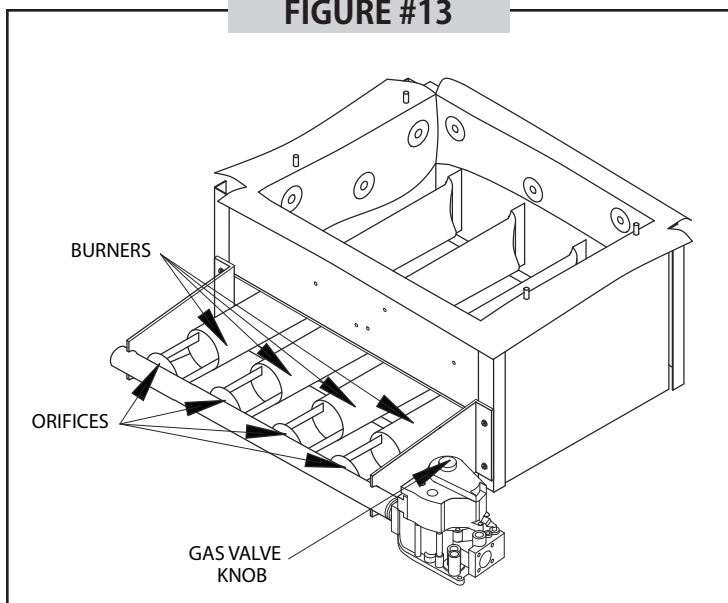
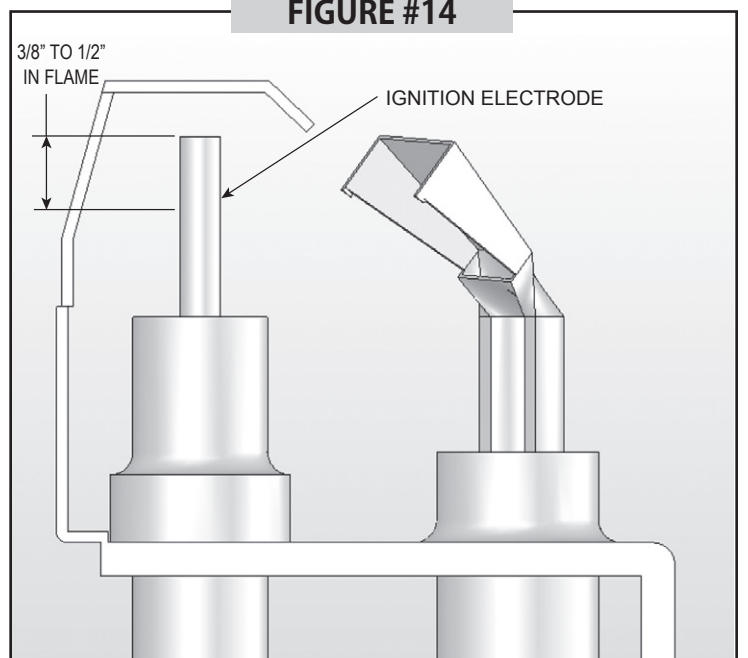
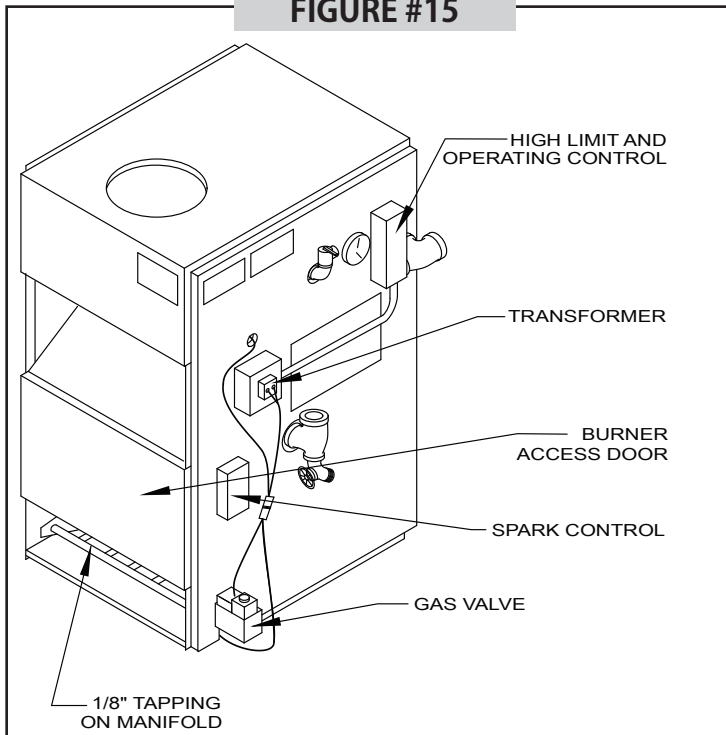

FIGURE #14



CHECKING GAS INPUT RATES TO BOILER

FIGURE #15



Gas input to the boiler can be adjusted by removing the protective cap on the pressure regulator, (See figures #8 & #9), and turning the screw clockwise ↻ to increase input and counterclockwise ↻ to decrease input. Natural gas manifold pressure should be set at approximately 3.5 inches water column. Propane gas manifold pressure should be set at approximately 10.5 inches water column. These manifold pressures are taken at the outlet side of the gas valve. (See figures #8 & #9)

To check for proper flow of natural gas to the boiler,

divide the input rate shown on the rating plate by the heating value of the gas obtained from the local gas company. This will determine the number of cubic feet of gas required per hour. With all other gas appliances off, determine the flow of gas through the meter for two minutes and multiply by 30 to get the hourly rate. Make minor adjustments to the gas input as described above. If the proper rate cannot be obtained, contact the manufacturer.

CHECK SAFETY CONTROL CIRCUIT

after burner adjustments are made, for satisfactory operation.

1. Pilot: With main burner operating, turn the pilot gas adjusting screw clockwise ↻ until pilot gas is turned off. (Refer figures #8 & #9) Within 90 seconds the main gas control should close, shutting off the gas to the main burner.

2. High limit control (figure #15) Remove cover and note temperature setting. Decrease this setting to the minimum and operate boiler. When the boiler water temperature exceeds the control temperature setting, the control will open the circuit, closing the automatic main gas valve.

OPTIONAL CONTROLS & WIRING

The following descriptions outline control options for MAGB modular systems.

AMB4A and AMB8A Multiple Boiler Sequencers

The AMB4A and AMB8A multiple boiler sequencers are capable of sequentially step firing up to 4 (AMB4A) or 8 (AMB8A) heating boilers. The number of boilers fired is adjusted by the AMB control depending on the system heating load and outdoor temperature. The AMB control will adjust the control point of the system water temperature based on the temperature that the outdoor air sensor is reading. The number of hours on each boiler in the system is recorded and each day the AMB control will choose the boiler with the fewest hours to be the lead boiler for the day to attempt to run each boiler equally and extend boiler life. Setpoint, reset ratio, rotation and many other features are easily programmed in the field through the four button user interface.

Operation

When used in a continuous application the AMB will regulate the water temperature in the system through the use of the water sensor and it will always keep the water warm. The AMB will monitor the water temperature until the temperature drops the number of degrees below the control point that the temperature differential feature is set to. The control will then bring on the lead boiler. The AMB will monitor the boiler temperature and if it has not reached the control point it will bring on the next boiler. Boilers will be phased on or off based on how close the water temperature is to the control point. If at any point the water temperature is 10°F above the control point, all boilers will turn off

Wiring on ARGO AMB Control to Multiple MAGB Boilers

FIGURE #16

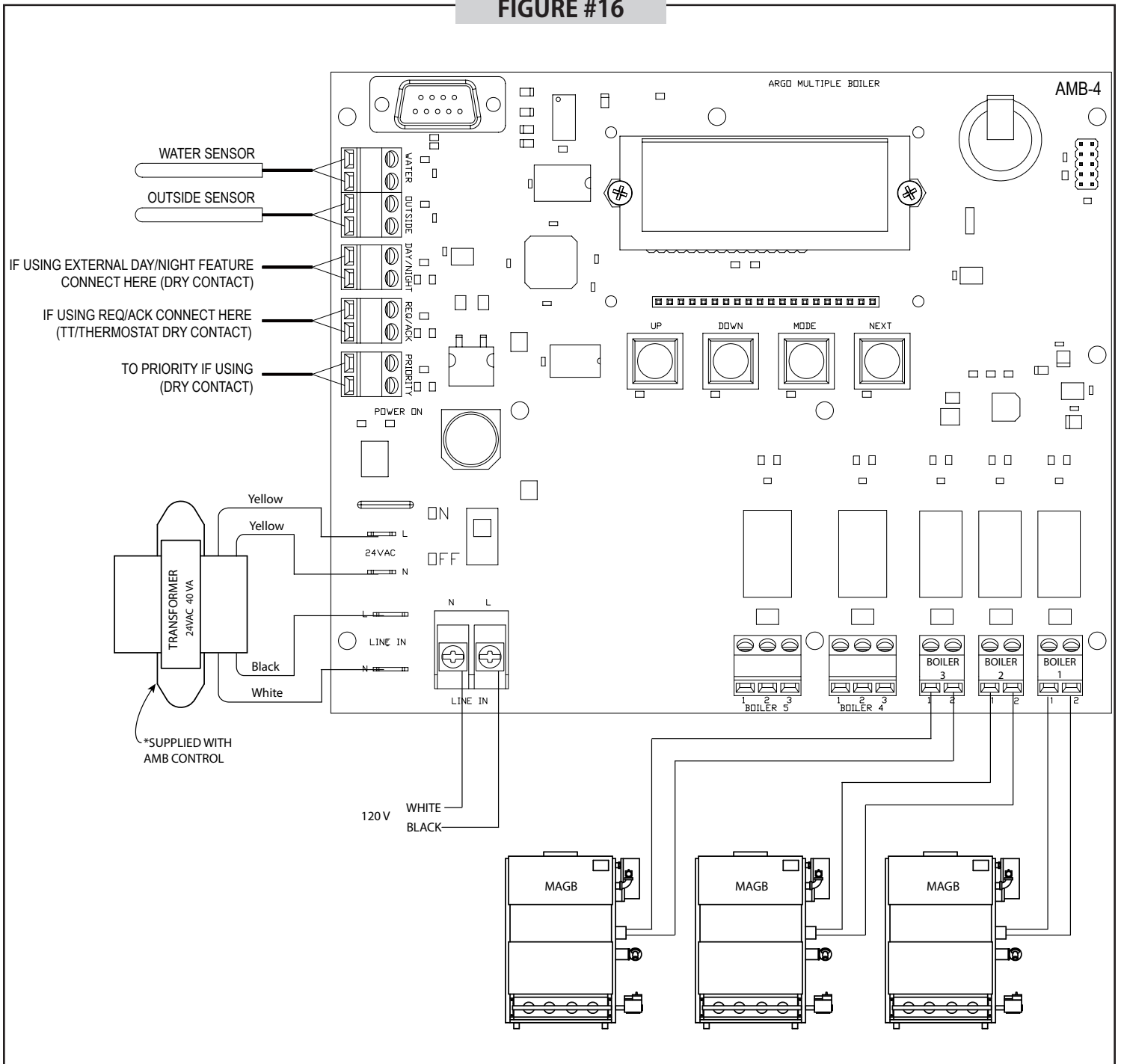

Consult the ARGO AMB installation manual for additional information on the ARGO AMB control.

MAGB SERIES REPLACEMENT PARTS

BASE

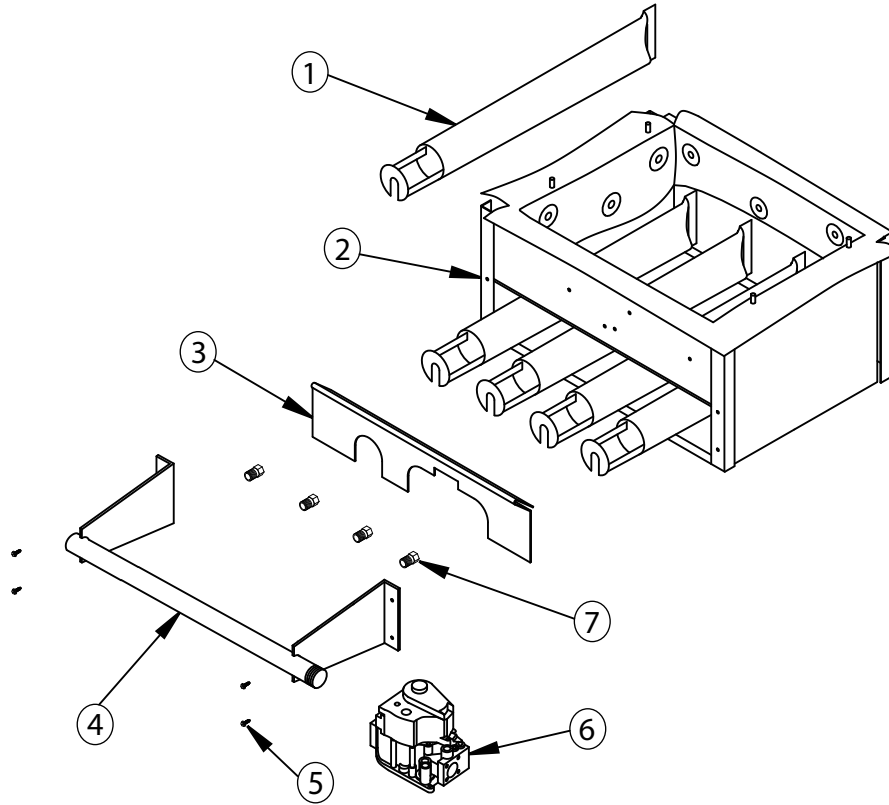

Item #	Description	Part #	Qty.
1	BURNER TUBE 1 1/2" - 250	240005543	5
	BURNER TUBE 1 1/2" - 300		6
2	BASE W/INSUL - 250	5611605	1
	BASE W/INSUL - 300	5611606	
3	BURNER DOOR - 250	109008515	1
	BURNER DOOR - 300	109008516	
4	MANIFOLD - 250	356-2-1.05	1
	MANIFOLD - 300	356-2-1.06	
5	SCREW 1/4 - 20 X 1/2 SELF TAP	HW-005.01	4

Item #	Description	Part #	Qty.
6	GAS VALVE VR8200H - 50 - 300 24V LP	VG00307	1
	GAS VALVE VR8304H4 - 175-300 SPARK NAT	VG01103	
	GAS VALVE VR8304 - 50-300 SPARK LP	VG01104	
	GAS VALVE VR8300H4 - 250 & 300 24V NAT	VG01201	
7	ORIFICE 3.2mm NAT - 250 BASE	240007406	5
	ORIFICE 3.2mm NAT - 300 BASE	240007406	6
	ORIFICE #47 LP - 250 BASE	355-1-5.04	5
	ORIFICE #47 LP - 300 BASE	355-1-5.04	6
	COMBUSTIBLE BASE FLOORING - 250	325-2-8.05	1
	COMBUSTIBLE BASE FLOORING - 300	325-2-8.06	

MAGB SERIES REPLACEMENT PARTS

JACKET

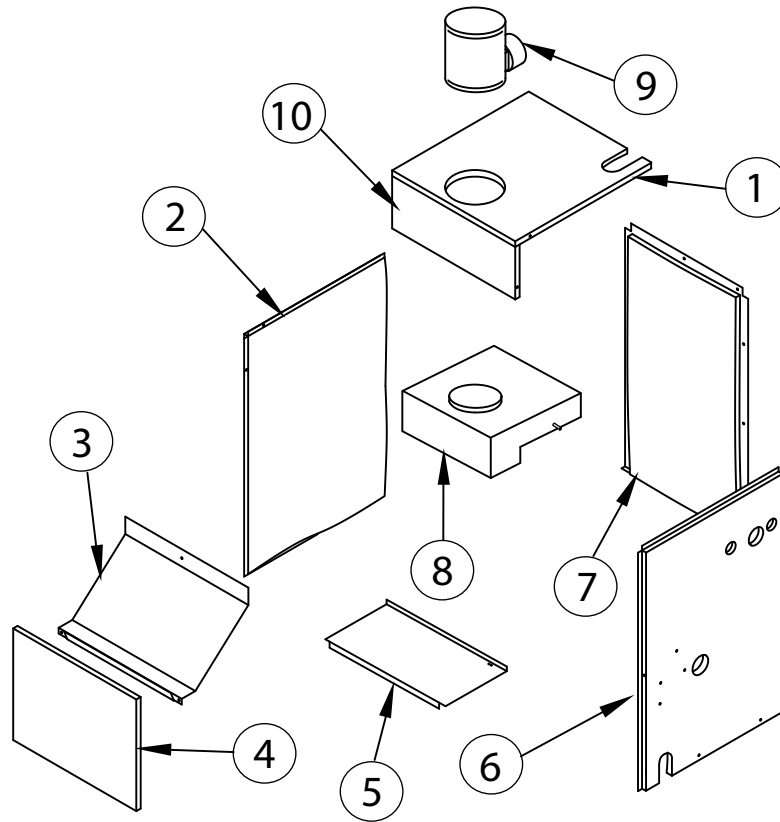

ITEM #	DESCRIPTION	PART #	QTY.
1	PANEL - TOP MAGB 250	31621506	1
	PANEL - TOP MAGB 300	31621507	
2	PANEL - LEFT MAGB 250 & 300	3162704	1
3	DRAFT DEFLECTOR MAGB 250	3162505	1
	DRAFT DEFLECTOR MAGB 300	3162506	
4	PNL LWR ACCES MAGB 250	3161105	1
	PNL LWR ACCES MAGB 300	3161106	
5	PANEL - BASE MAGB 250	109008532	1
	PANEL - BASE MAGB 300	109008533	
6	PANEL - RIGHT MAGB 250 & 300	3162703	1
7	PANEL - REAR MAGB 250	3162605	1
	PANEL - REAR MAGB 300	3162606	
8	FLUE COL MAGB 250	109008527	1
	FLUE COL MAGB 300	3462106	
9	DAMPER 8" MAGB 250	240006940	1
	DAMPER 9" MAGB 300	240006941	
10	PNL- UPPER ACCESS MAGB 250	31621206	1
	PNL- UPPER ACCESS MAGB 300	31621207	

HEAT EXCHANGER

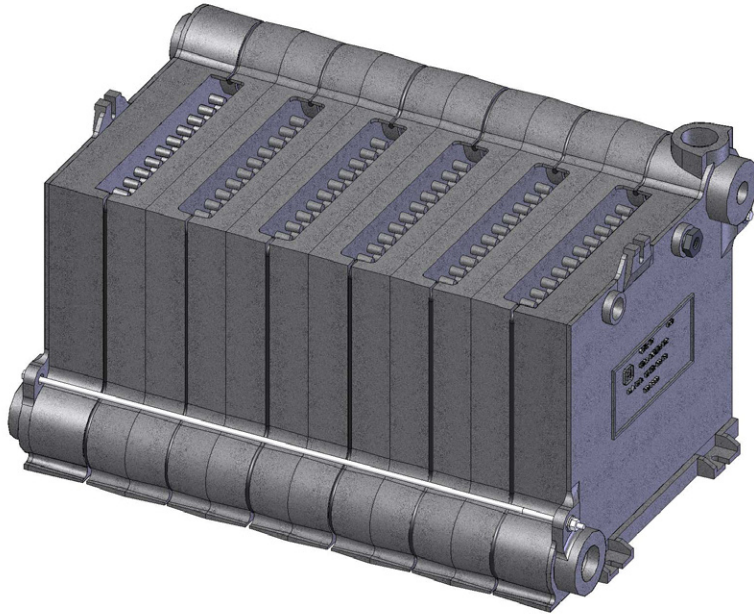

Fully Assembled Heat Exchangers	
91200014	Heat Exchanger (6 Section)
91200013	Heat Exchanger (7 Section)

MAGB SERIES REPLACEMENT PARTS

SPARK

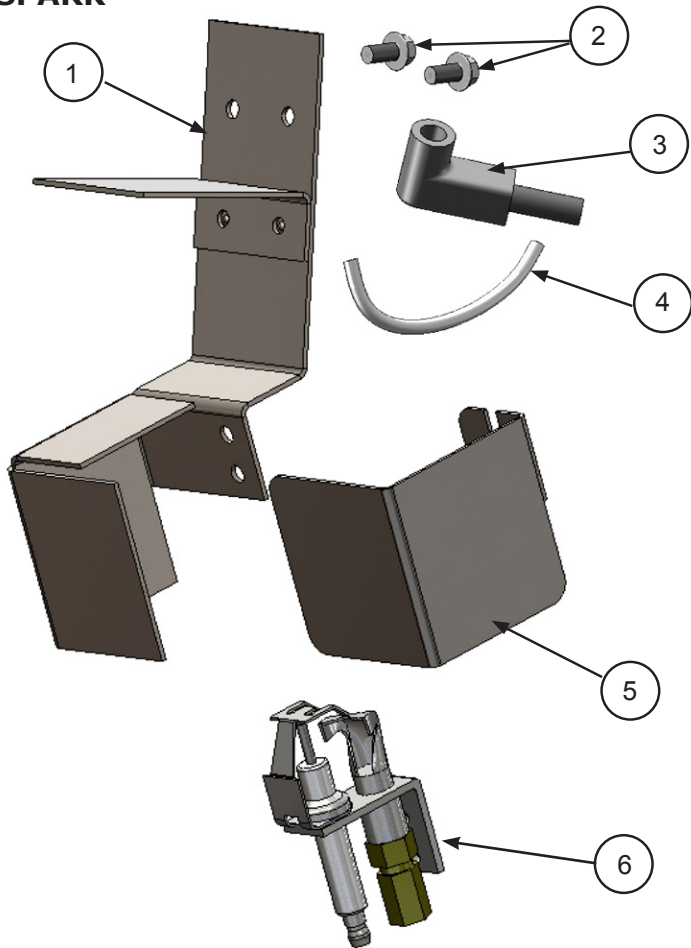

Spark Pilot Kit - Natural Gas 550001911

Spark Pilot Kit - LP/Propane 550001912

Item	Description	Qty.
1	PILOT BRACKET ASSEMBLY	1
2	BRACKET SCREW	2
3	SPARK CABLE	1
4	PILOT TUBING, 1/8" x 24"	1
5	Pilot Shield	1
6	Natural Gas Q345A PILOT	1
	LP Q345A Pilot	

* Included with #3 - Pilot Tube Assembly Kit (above)

CONTINUOUS PILOT

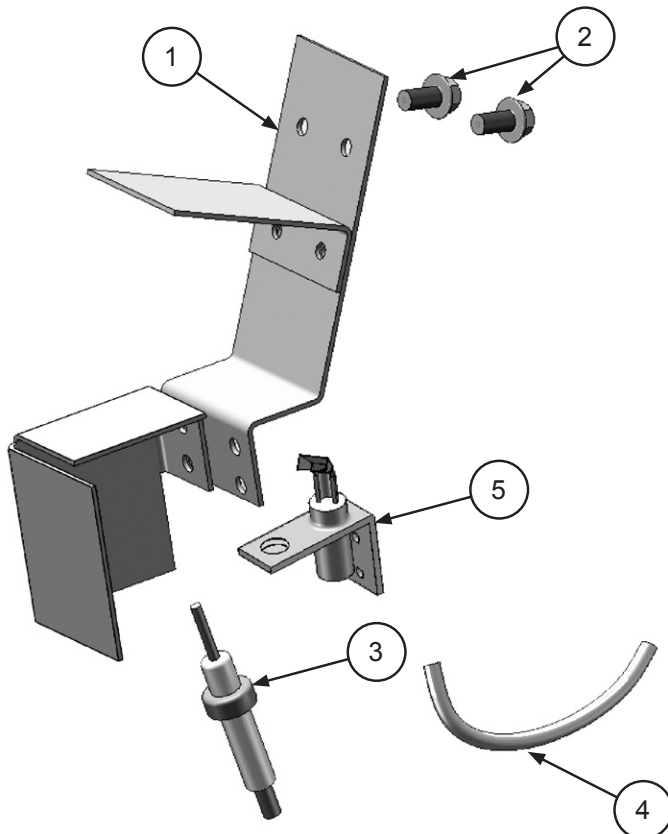

Continuous Pilot Kit - Natural Gas 550001926

Continuous Pilot Kit - LP/Propane 550001927

Item	Description	Qty.
1	PILOT BRACKET ASSEMBLY	1
2	BRACKET SCREW	2
3	THERMOCOUPLE Q309	1
4	PILOT TUBING, 1/8" x 24"	1
5	Natural Gas Q314A PILOT	1
	LP Q314A Pilot	

* Included with #3 - Pilot Tube Assembly Kit (above)

MAGB SERIES REPLACEMENT PARTS

ELECTRICAL

(NOTE: quantities are per module)

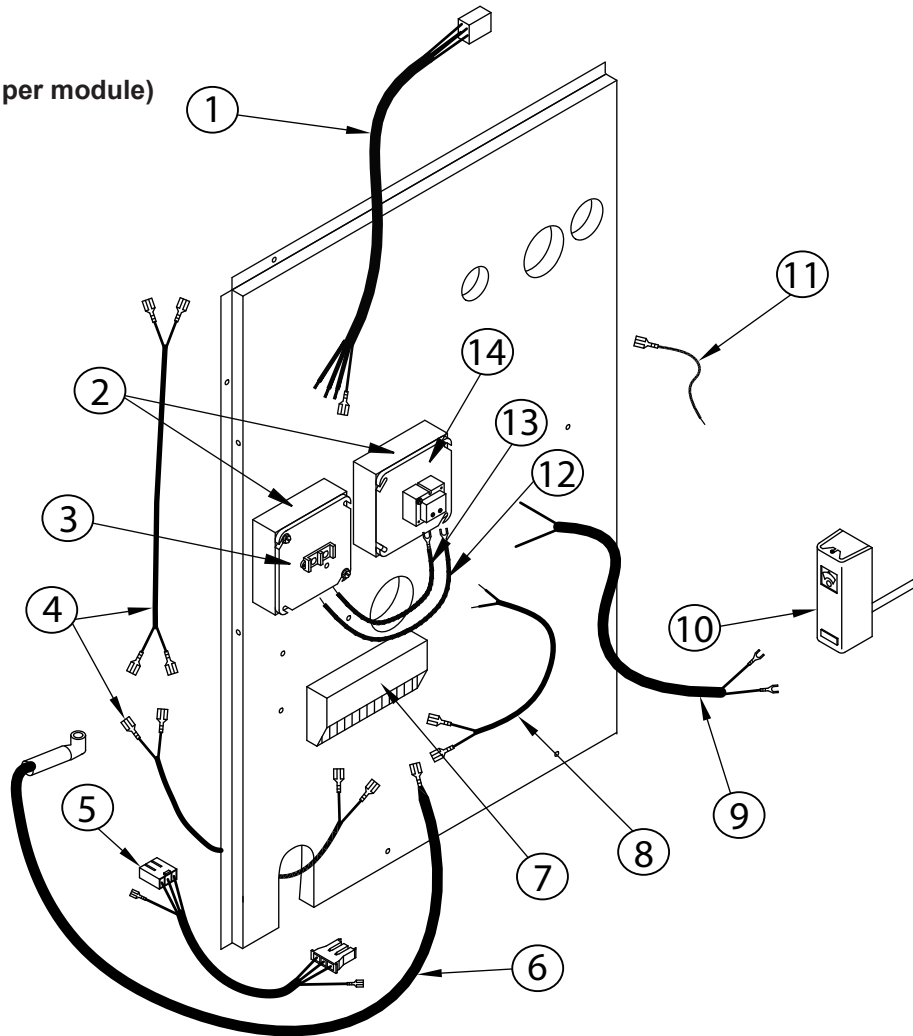

ITEM	DESCRIPTION	P/N	QTY.
1	CABLE - DAMPER 60"	37413101	1
2	JCT BOX 4X4X1-1/2	EF-013.01	2
3	ELEC 4"X4" COVER/TERM STRIP	EF04401	1
4	WIRE ASSY ROLLOUT/SPILL SWITCH 28"	37513301	2
5	HARNESS IGNITION TO GAS VALVE	37413602	1
6	PILOT IGNITION CABLE 30" (FOR SPARK ONLY)	240007093	1
7	PLT SPARK CTRL HW (FOR SPARK ONLY)	14662070	1
8	WIRE - J-BOX TO CONTROLS 27"	37413801	1
9	HARNESS TRANSFORMER 30"	272-1-3.00	1
10	CONTROL L4006-1827 HW	AQ-008.00	1
11	WIRE JUMPER TO "TT", 8" (LOCATED UNDER TERM STRIP)	37519001	1
12	WIRE TRANSFORMER BROWN 15"	37413001	1
13	WIRE TRANSFORMER WHITE 15"	37413002	1
14	TRANSFORMER 125V-24V 50VA	14662305	1

MAGB SERIES REPLACEMENT PARTS

PIPING

(NOTE: quantities are per module)

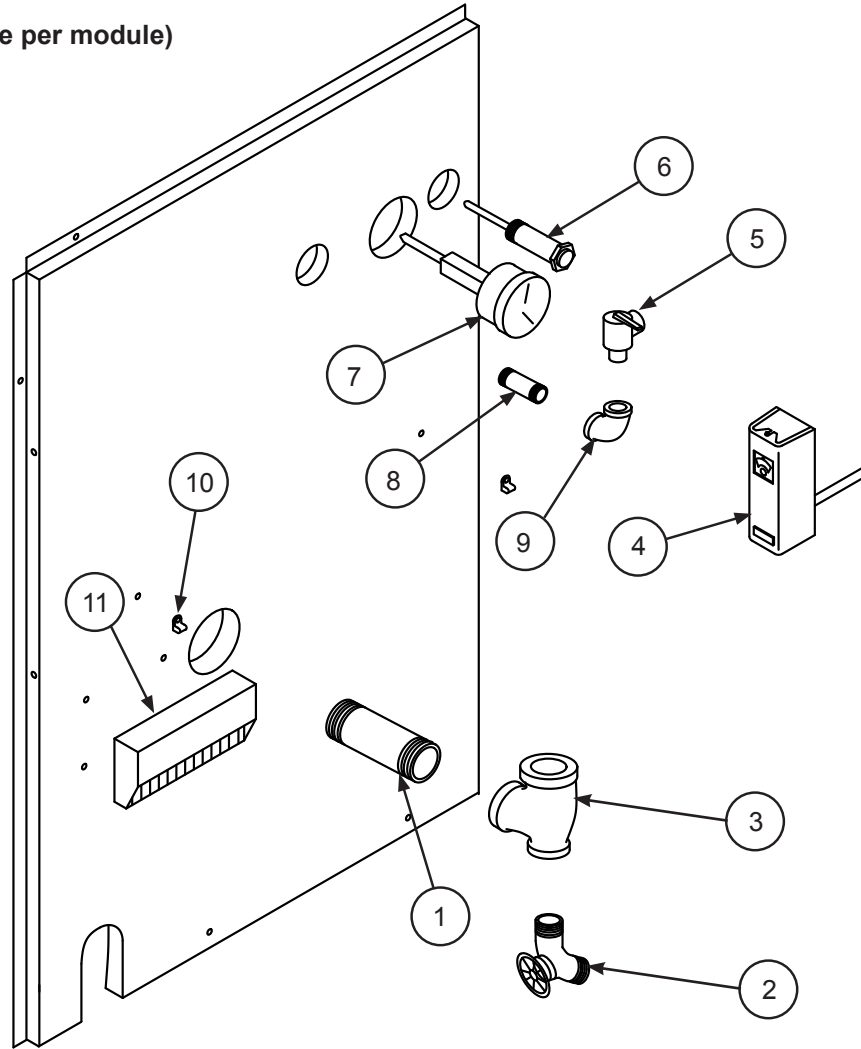

ITEM	DESCRIPTION	P/N	QTY.
1	PIPE - NPL 1.1/2X4.1/2 NPT	PF-001.07	1
2	DRAIN - SHORT	HW-016.03	1
3	PIPE - TEE 1.1/2X3/4X1.1/2	1510002	1
4	CONTROL L4006A (AQUASTAT)	AQ-008.00	1
5	RELIEF VALVE 30#	VR-001.01	1
6	WELL 3/4"X1.1/2"	1635001	1
7	GAUGE - THERALTIMETER	1260006	1
8	PIPE - NPL 3/4"X4"	1310001	1
9	PIPE - ELBOW 3/4" 90°	1190001	1
10	CLAMP #3600 WHITE	EF03601	2
11	PLT SPARK CTRL	14662070	1

ROLLOUT & SPILL SWITCH

Item #	Description	Part #	Qty.
1	TEMP. SENSOR BRACKET	109008518	1
2	CONTROL-FIXED TEMPERATURE THERMO (ROLLOUT SWITCH; ALSO USED AS SPILL SWITCH)	AQ02101	2
3	SCREW - #6 X 1/4 HEX HD	HW06501	2

NOTE: The rollout switch is located at the burner manifold. The spill switch is located in the draft hood.

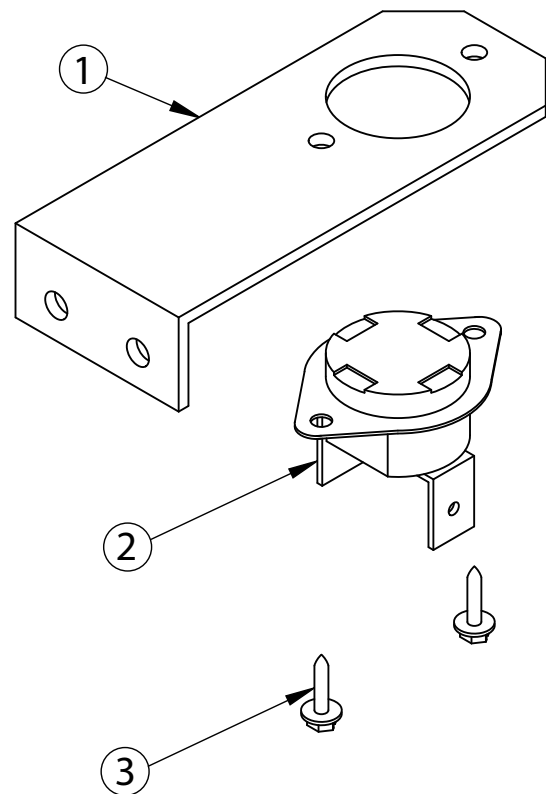



UTICA BOILERS
2201 Dwyer Avenue
Utica NY 13501

web site: www.ecrinternational.com