



CDVB SERIES

Gas Fired Boilers

For Forced Hot Water

INSTALLATION, OPERATION & MAINTENANCE MANUAL



COLUMBIA COMPANY

Main offices and Factory: Pottstown, PA

P/N 37616101, Rev. F [05/2012]

Introduction..... 3

Boiler Ratings, Capacities & Dimensions..... 4

Ventilation & Combustion Air..... 6

Connecting Supply & Return Piping 7

Applicable Federal Codes11

Vent System Modification.....11

Horizontal Vent Pipe Installation Instructions.....12

Vertical Vent Pipe Installation Instructions.....22

Connecting Gas Service.....28

Electrical Wiring29

Lighting Instructions31

Sequence Of Operation.....32

General Instruction For Seasonal Startup & Maintenance.....33

Replacement Parts.....37

**KEEP THIS MANUAL NEAR BOILER AND
RETAIN FOR FUTURE REFERENCE.**

**IMPORTANT: Read the following instructions
COMPLETELY before installing!**

SAFETY SYMBOLS

The following defined symbols are used throughout this manual to notify the reader of potential hazards of varying risk levels.

	DANGER
Indicates a hazardous situation which, if not avoided, WILL result in death or serious injury.	

	CAUTION
Indicates a hazardous situation which, if not avoided, may result in minor or moderate injury.	

	WARNING
Indicates a hazardous situation which, if not avoided, could result in death or serious injury.	

	NOTICE
Indicates information which should be followed to ensure proper installation and operation.	



C.S.A. Certified for
Natural Gas or Propane



Tested for 100 psi. ASME
Working Pressure

WARNING



1. Keep boiler area clear and free from combustible materials, gasoline and other flammable vapors and liquids.
2. DO NOT obstruct air openings to boiler room.
3. Modification, substitution or elimination of factory equipped, supplied or specified components may result in property damage, personal injury or loss of life.
4. To owner: Installation and service of this boiler must be performed by qualified installer.
5. To installer: Leave all instructions with boiler for future reference.
6. Boiler installation must conform to Commonwealth of Massachusetts code 248 CMR when installed in Commonwealth of Massachusetts. This includes, but is not limited to, installation by licensed plumber or gas fitter.

7. Install boiler such that gas ignition system components are protected from water, (dripping, spraying, rain, etc.), during appliance operation and service, (circulator replacement, condensate trap, control replacement, etc.).
8. Requirements for Commonwealth of Massachusetts: Boiler installation must conform to Commonwealth of Massachusetts code 248 CMR which includes but is not limited to installation by licensed plumber or gas fitter.
9. **FOR INSTALLATION ON NON-COMBUSTIBLE FLOORS ONLY. *Boiler must NOT be installed on carpeting.**
10. Minimum clearances to combustible constructions are:

TOP	18 in. (457mm)
FRONT	6 in (152mm)
FLUE CONNECTOR	6 in (152mm)
REAR.....	4 in. (102mm)
CONTROL SIDE.....	9 in. (229mm)
OTHER SIDE	3 in. (76mm)
VENT PIPE	6 in. (152mm)

WARNING



Improper installation, adjustment, alteration, service or maintenance can cause injury or property damage.

NOTICE

- Greater clearances for access should supersede fire protection clearances.
- * For installation on combustible flooring Special Base MUST BE USED. (See Replacement Parts Section)

1. Installation must conform to requirements of authority having jurisdiction or, in absence of such requirements, to the National Fuel Gas Code, ANSI Z223.1/NFPA 54 and/or Natural Gas and Propane Installation Code, CAN/BS149.1
2. Where required by the authority having jurisdiction, installation must conform to Standard for Controls and Safety Devices for Automatically Fired Boilers, ANSI/ASME No. CSD-1.
3. This boiler is classified as Category I and III and vent installation shall be in accordance with latest revision of the National Fuel Gas Code, ANSI Z223.1 or applicable provisions of the local building codes.
4. LOCATE BOILER on level, solid base as near outside wall as possible and centrally located with respect to heat distribution system as practicable.
5. Allow 24 inches at front and right side for servicing and cleaning.
6. When installed in utility room, door should be wide enough to allow largest boiler part to enter, or to permit replacement of another appliance such as a water heater.

WARNING



All installations of boilers and venting should be done only by a qualified expert and in accordance with the appropriate utica boilers manual. Installing or venting a boiler or any other gas appliance with improper methods or materials may result in serious injury or death due to fire or to asphyxiation from poisonous gases such as carbon monoxide which is odorless and invisible.

Figure 1 -Boiler Dimensions

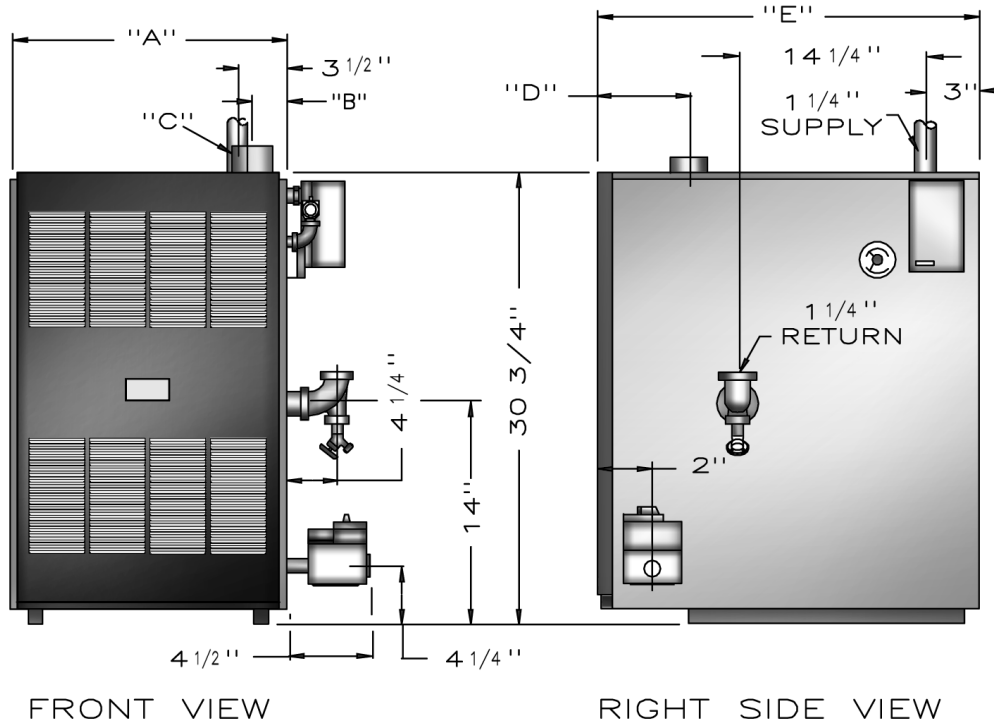

4 1/2" 4 1/4"

FRONT VIEW

RIGHT SIDE VIEW

Table 1- DIMENSIONS FOR NATURAL GAS							
Model #	Natural Gas Inlet	Dimensions					Pump size Supply & Return Tappings
		A	B	C	D	E	
-50	1/2"	11 1/4	2 1/8	3	6 3/8	27	1 1/4"
-100	1/2"	15 1/8	4 1/8	3	6 3/8	27	1 1/4"
-125	1/2"	19	6	3	6 3/8	27	1 1/4"
-150	1/2"	19	6	4	6 3/8	27	1 1/4"
-200	1/2"	22 7/8	8	4	7	28	1 1/4"

NOTE: For altitudes above 2,000 ft. ratings should be reduced at the rate of 4% for each 1,000 ft. above sea level.

Table 2 - RATINGS AND CAPACITIES						
Model #	Input Btu/hr	Heating Capacity Mbh ⁽¹⁾	Net Rating Water, Mbh ^{(1) (2)}	AFUE	No. of Burners	Water Content (Gals.)
-50	50,000	42	37	83.0%	1	2.4
-100	100,000	82	71	82.0%	2	4.0
-125	125,000	103	90	82.0%	3	5.6
-150	150,000	122	1060	80.0%	3	5.6
-200	199,999	160	139	80.0%	4	7.2
⁽¹⁾ Mbh = 1000 Btu per hour ⁽²⁾ Net Water Ratings shown based on piping and pickup allowance of 1.15. Contact manufacturer before selecting boiler for installations having unusual piping and pickup requirements, such as intermittent system operation, extensive piping systems, etc.						

STANDARD EQUIPMENT: Boiler Jacket, Cast Iron Boiler Battery, Combination Aquastat Relay, Theraltimeter Gauge, Circulator, Main Gas Burners, Electric Ignition System, A.S.M.E relief Valve, Drain Valve, Induced Draft Fan, and Safety Pressure Switch

All boilers are design certified for installation on non-combustible floors. For installation on combustible floors, use combustible floor kit.

Boiler is Category III Designed Certified appliance which requires a special horizontal through the wall venting system. Only HEAT-FAB SAF-T-VENT™, FLEX-L STAR-34™, ProTech™ FasNSeal, and Z-FLEX Z-VENT™ vent material products shall be used.

Electric service to be 120 Volts, 15 Amps, 60 Hz.

VENTILATION & COMBUSTION AIR

Provide combustion air and ventilation air in accordance with the section "Air for Combustion and Ventilation," of the National Fuel Gas Code, ANSI Z223.1/NFPA 54, or Sections 8.2, 8.3 or 8.4 of Natural Gas and Propane Installation Code, CAN/CSA B149.1, or applicable provisions of local building codes.

Provide make-up air where exhaust fans, clothes dryers, and kitchen ventilation equipment interfere with proper operation.

National Fuel Gas Code recognizes several methods of obtaining adequate ventilation and combustion air. Requirements of the authority having jurisdiction may override these methods.

- Engineered Installations. Must be approved by authority having jurisdictions.
- Mechanical Air Supply. Provide minimum of 0.35 cfm per Mbh for all appliances located within space. Additional requirements where exhaust fans installed. Interlock each appliance to mechanical air supply system to prevent main burner operation when mechanical air supply system not operating.
- All Indoor Air. Calculate minimum volume for all appliances in space. Use a different method if minimum volume not available.
 - Standard Method. Cannot be used if known air infiltration rate is less than 0.40 air changes per hour. See Table 3 for space with boiler only. Use equation for multiple appliances.

$$\text{Volume} \geq 50 \text{ ft}^3 \times \text{Total Input [Mbh]}$$
 - Known Air Infiltration Rate. See **Table 3** for space with boiler only. Use equation for multiple appliances. Do not use an air infiltration rate (ACH) greater than 0.60.

$$\text{Volume} \geq 15 \text{ ft}^3/\text{ACH} \times \text{Total Input [Mbh]}$$
 - Refer to National Fuel Gas Code for opening requirements between connection indoor spaces.

- All Outdoor Air. Provide permanent opening(s) communicating directly or by ducts with outdoors.
 - Two Permanent Opening Method. Provide opening commencing within 12 inches of top and second opening commencing within 12 inches of bottom enclosure.
 - Direct communication with outdoors or communicating through vertical ducts. Provide minimum free area of 1 in² per 4 Mbh of total input rating of all appliances in enclosure.
 - Communicating through horizontal ducts. Provide minimum free area of 1 in² per 2 Mbh of total input rating of all appliances in enclosure.
 - One Permanent Opening Method. Provide opening commencing within 12 inches of top of enclosure. Provide minimum clearance of 1 inch on sides and back and 6 inches on front of boiler (does not supersede clearance to combustible materials).
 - Combination Indoor and Outdoor Air. Refer to National Fuel Gas Code for additional requirements for louvers, grilles, screens and air ducts.
- Combination Indoor and Outdoor Air. Refer to National Fuel Gas Code for application information.

National Gas and Propane Installation Code Requires providing air supply in accordance with:

- Section 8.2 and 8.3 when combination of appliances has a total input of up to and including 400 Mbh (120 kW).
 - Does not have draft control device.
- Section 8.4 when combination of appliances has total input exceeding 400 Mbh (120 kW).
- Refer to Natural Gas and Propane Installation Code for specific air supply requirements for enclosure or structure where boiler is installed, including air supply openings and ducts.

Input Mbh	Standard Method	Known Air Infiltration Rate Method (Air Changes Per Hour)					
		0.1	0.2	0.3	0.4	0.5	0.6
50	2500	7500	3750	2500	1875	1500	1250
100	5000	15000	7500	5000	3750	3000	2500
125	6250	18750	9375	6250	4688	3750	3125
150	7500	22500	11250	7500	5625	4500	3750
200	10000	30000	15000	10000	7500	6000	5000

CONNECTING SUPPLY & RETURN PIPING

IMPORTANT: Circulators in following illustrations are mounted on system supply side, but mounting on system return side is also acceptable practice.

1. Maintain minimum clearance of one inch (25mm) to hot water pipes.
 2. Boiler, when used in connection with refrigeration system, must be installed so chilled medium is piped in parallel with boiler with appropriate valves to prevent chilled medium from entering boiler.
 3. Boiler piping system of hot water boiler connected to heating coils located in air handling units where they may be exposed to refrigerated air circulation must be equipped with flow control valves or other automatic means to prevent gravity circulation of boiler water during cooling cycle.
 4. Hot water boiler installed above radiation level or as required by the Authority having jurisdiction, must be provided with low water cutoff device either as part of boiler or at time of boiler installation.
 5. When boiler is connected to heating system that utilizes multiple zoned circulators, each circulator must be supplied with flow control valve to prevent gravity circulation.
 6. Hot water boilers and system must be filled with water and maintained to minimum pressure of 12 psi.
7. Bypass piping is option which gives ability to adjust supply boiler water temperature to fit system or condition of installation. This method of piping, however, is not typically required for baseboard heating systems. Typical installations where bypass piping is used are as follows:
 - A. This method is used to protect boilers from condensation forming due to low temperature return water. Generally noticed in large converted gravity systems or other large water volume systems. See **figure 2**.
 - B. This method is used to protect systems using radiant panels and the material they are encased in from high temperature supply water from boiler, and protect boiler from condensate. See **figure 3** and **4**.
 - C. This method is used to protect boilers from condensate forming as well as protecting heating system from high water temperatures, see **figure 4**.

Figure 2 - BYPASS PIPING

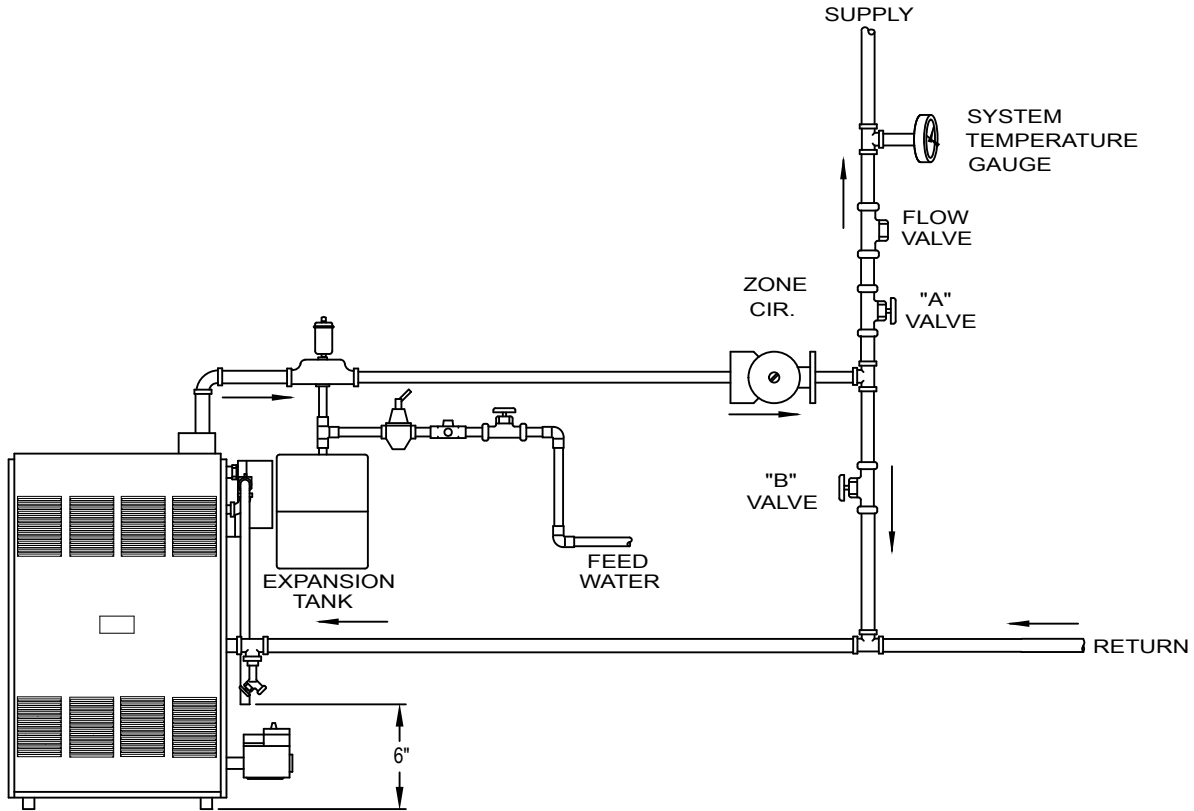

Figure 3 - MIXING VALVE PIPING

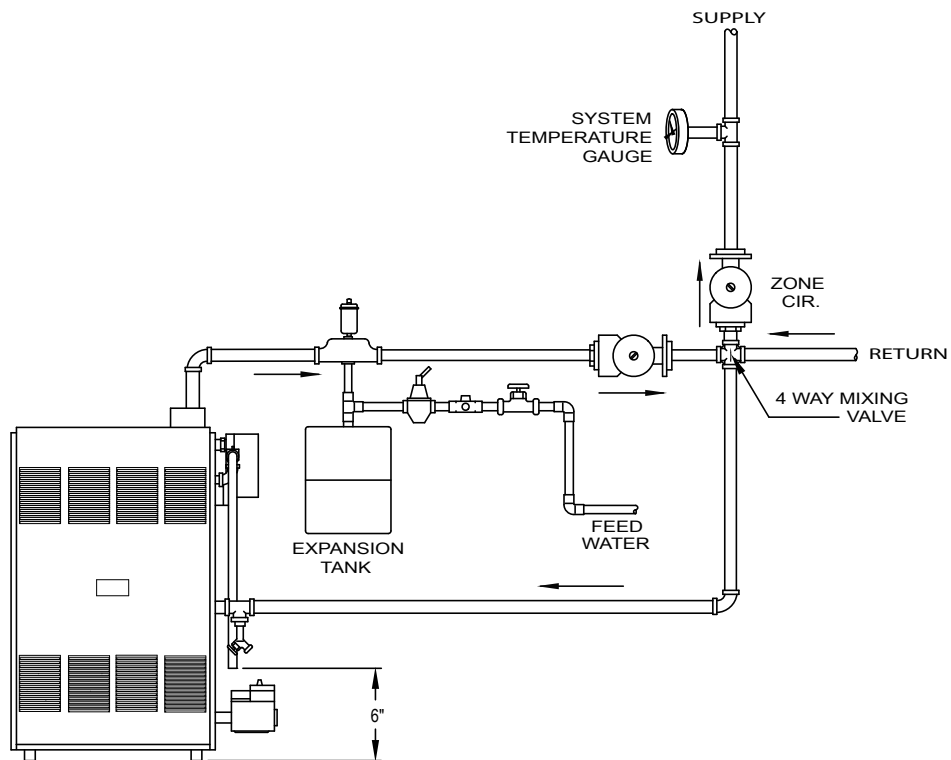
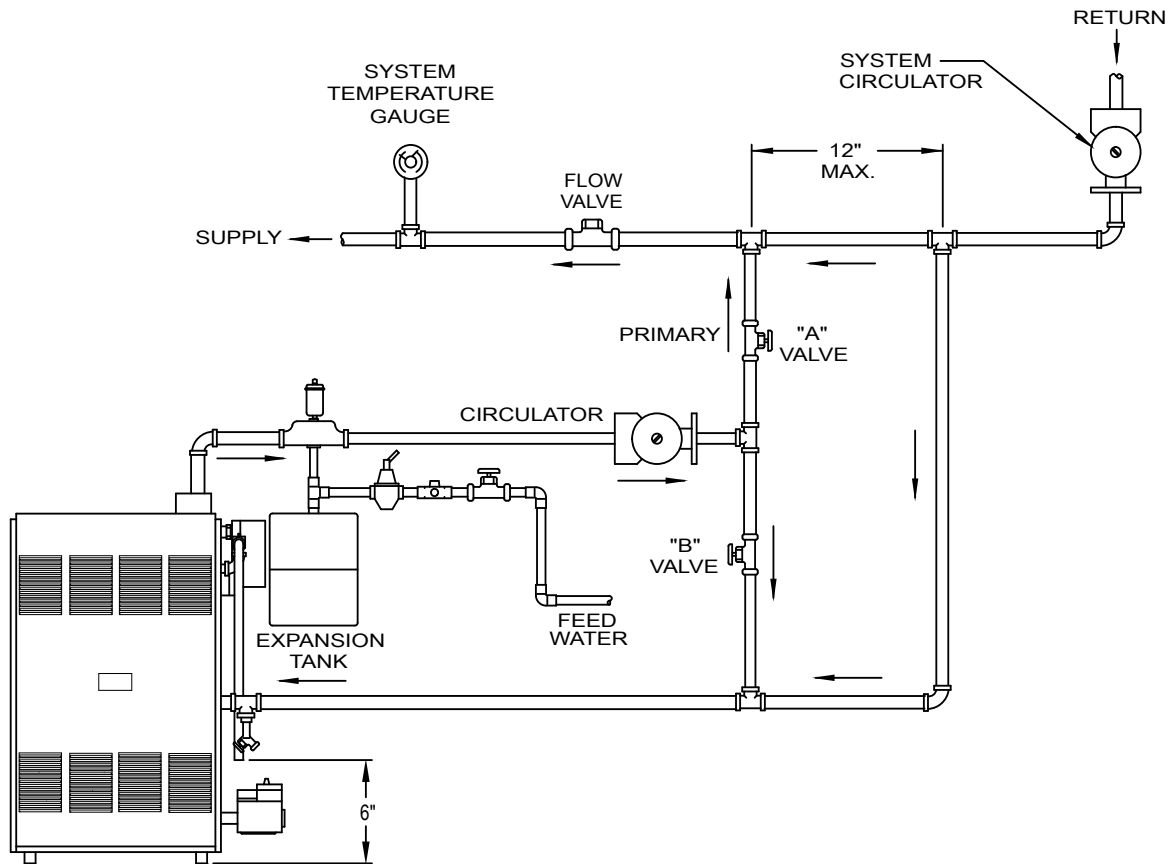

Figure 4 - PRIMARY SECONDARY PIPING WITH BYPASS



NOTE #1: When using bypass piping, adjust valves A and B until desired system temperature is obtained.

NOTE #2: Bypass loop must be same size piping as the supply and return piping.

8. Installation using circulators is shown in **figure 5**.
9. Installation using zone valves is shown in **figure 6**.
10. For further piping information refer to the I=B=R Installation and Piping Guide.

WARNING

To avoid burns, scalding, or water damage due to discharge of steam and/or hot water during operation, a discharge line shall be installed to relief valve outlet connection.

Discharge line shall:

- connect to relief valve outlet and piped down to safe point of disposal. Check local codes for maximum distance from floor or allowable safe point of discharge.
- be of pipe size equal to or greater than that of the relief valve outlet over the entire length of discharge line;
- have no intervening shutoff valve between safety relief valve and discharge to atmosphere (do not plug or place any obstruction in discharge line.
- terminate freely to atmosphere where any discharge will be clearly visible and at no risk of freezing;
- allow complete drainage of the valve and the discharge line;
- be independently supported and securely anchored to avoid applied stress on the relief valve;
- be as short and straight as possible;
- terminate with plain end (not threaded);
- be constructed of material suitable for exposure to temperatures of 375° F; or greater.

Refer to local codes and appropriate ASME Boiler and Pressure Vessel Code for additional installation requirements.

WARNING

Burn and scald hazard. Safety relief valve could discharge steam or hot water during operation. Install discharge piping per these instructions.

11. Install discharge piping from safety relief valve.

- Use ¾" or larger pipe.
- Use pipe suitable for temperatures of 375°F (191°C) or greater.
- Individual boiler discharge piping shall be independent of other discharge piping.
- Size and arrange discharge piping to avoid reducing safety relief valve relieving capacity below minimum relief valve capacity stated on rating plate.
- Run pipe as short and straight as possible to location protecting user from scalding and properly drain piping.
- Install union, if used, close to safety relief valve outlet.
- Install elbow(s), if used, close to safety relief valve outlet and downstream of union (if used).
- Terminate pipe with plain end (not threaded).

Figure 5 - Piping with Circulator

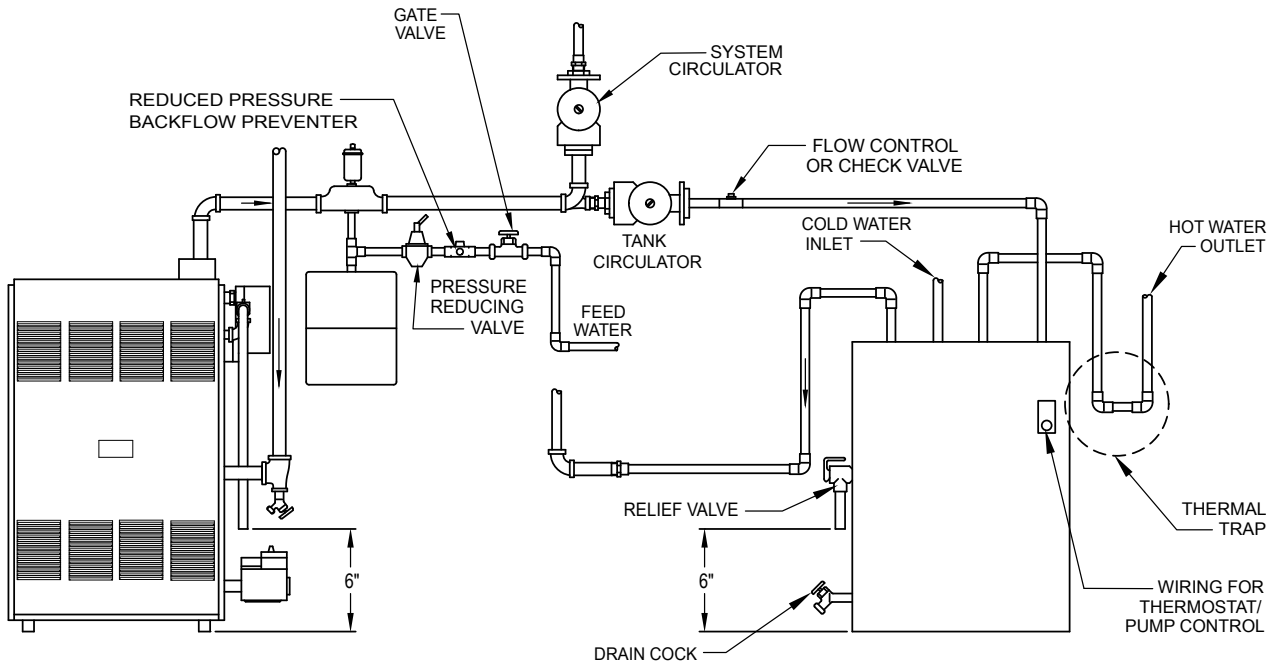
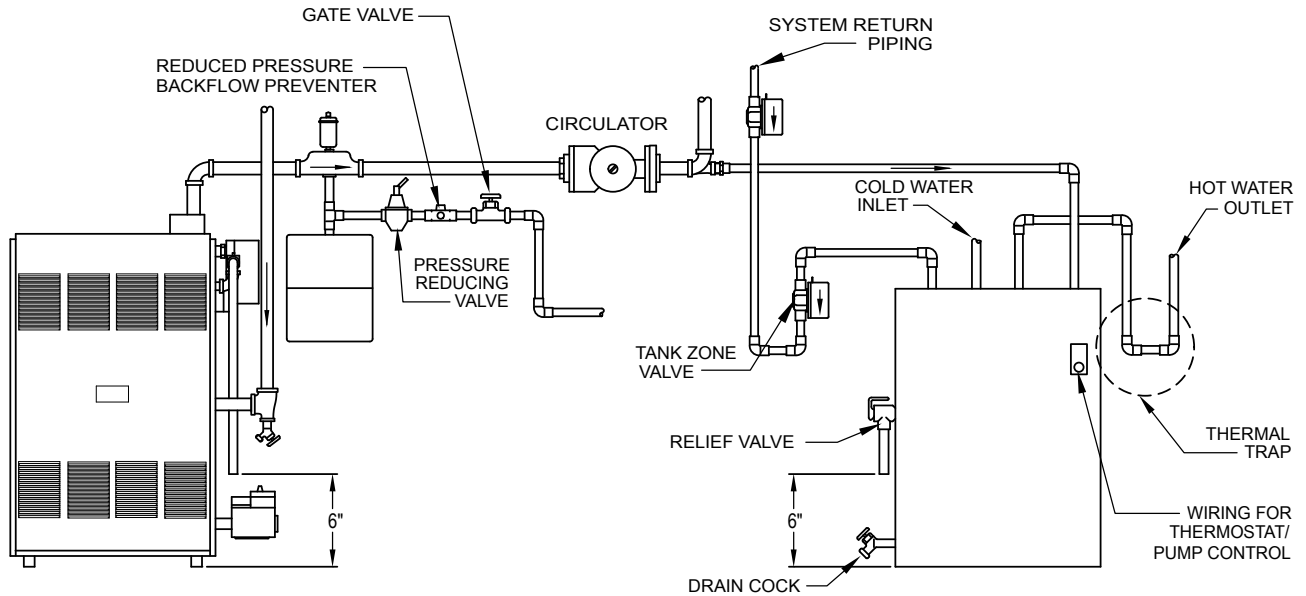

Figure 6 - Piping with Zone Valves



WARNING



All installations of boilers and venting should be done only by a qualified expert and in accordance with the appropriate installation manual. Installing or venting a boiler or any other gas appliance with improper methods or materials may result in serious injury or death due to fire or to asphyxiation from poisonous gases such as carbon monoxide which is odorless and invisible.

APPLICABLE FEDERAL CODES

NFPA 54/ANSI Z223.1, National Fuel Gas Code and NFPA/ANSI 211, Chimneys, Fireplaces, Vents and Solid Fuel Burning Appliances. These codes contain information on special gas vents for Category II, III and IV appliances, vent sizing, location, air space clearances to combustibles and safe installation practices. The gas vent installer should be familiar with these Federal Codes as well as Local Codes and Regulations.

General Information Gas Vents And Appliances:

By Federal Codes, gas appliances are categorized by the pressure and temperature of the flue gas vented from the appliance. Category I and II appliances are natural draft (draft hood) vented, with high flue gas temperatures (Category I), and low flue gas temperatures (Category II). Category III and IV appliances are fan forced vents with high temperature (Category III) and low temperature (Category IV) flue gasses. Appliance efficiency is directly related to flue gas temperature. Higher efficiency appliances remove more heat from the gas, so they will have lower temperature flue products.

When flue gas temperatures are lowered, corrosive condensates may form in the gas vent or in the appliance. Condensates may form in Category II, III, IV appliance vents, so special, corrosive resistant venting systems are required for higher efficiency appliances.

WARNING



Vents for Category I appliances may not be suitable for use with Category II, III, or IV appliances because condensate may corrode the vent.

WARNING



Vents for Category III appliances may not be suitable for use with Category I appliances because flue gas temperatures may be too high.

VENT SYSTEM MODIFICATION

When an existing boiler is removed from a common venting system, the common venting system is likely to be too large for the proper venting of the appliances remained connected to it. If this situation occurs, the following test procedure must be followed:

REMOVAL OF BOILER FROM VENTING SYSTEM

At the time of removal of an existing boiler, the following steps shall be followed with each appliance remaining connected to the common venting system placed in operation, while the other appliances remaining connected to the common venting system are not in operation.

1. Seal an unused opening in the common venting system.
2. Visually inspect the venting system for proper size and horizontal pitch and determine there is no blockage or restriction, leakage, corrosion and other deficiencies which could cause an unsafe condition.
3. Insofar as is practical, close all building doors and windows and all doors between the space in which the appliances remaining connected to the common venting system are located and other spaces of the building. Turn on clothes dryers and any other appliance not connected to the common venting system. Turn on any exhaust fans, such as range hoods and bathroom exhausts, so they operate at maximum speed. Do not operate a summer exhaust fan. Close fireplace dampers.

4. Place in operation the appliance being inspected. Follow the lighting instructions. Adjust thermostat so appliance will operate continuously.
5. Test for spillage at the draft hood relief opening after 5 minutes of main burner operation. Use the flame of a match or candle, or smoke from a cigarette, cigar or pipe.
6. After it has been determined that each appliance remaining connected to a common venting system properly vents when tested as outlined above, return doors, windows, exhaust fans, fireplace dampers and any other gas burning appliances to their previous condition of use.
7. Any improper operation if the common venting system should be corrected so the installation conforms with the National Fuel Gas Code, ANSI Z223.1/NFPA 54, and/or the Natural Gas and Propane Installation Code, CAN/CSA B149.1. When resizing any portion of the common venting system, the common venting system should be resized to approach the minimum size as determined using the appropriate tables in Chapter 13 of the National Fuel Gas Code, ANSI Z223.1/NFPA 54, and/or the Natural Gas and Propane Installation Code, CAN/CSA B149.1.

**Horizontal Vent Pipe Installation Instructions
(Through the wall)**

This boiler is design certified for use with the following venting systems				
Company	HEAT-FAB®	FLEX-L®	Z-FLEX®	ProTech®
Product	SAF-T-VENT™	STAR-34™	Z-VENT™	FasNSeal™

CAUTION



The above vent pipe and fittings are used for venting gas burning category III and IV appliances. Do not use this vent pipe or fittings for venting appliances burning fuels such as wood, oil, kerosene or coal.

CAUTION



Do not use this vent pipe and fittings for venting incinerators of any kind.

WARNING



All installations of boilers and venting should be done only by a qualified expert and in accordance with the appropriate manufacturers manual. Installing or venting a boiler or any other gas appliance with improper methods or materials may result in serious injury or death due to fire or to asphyxiation from poisonous gases such as carbon monoxide which is odorless and invisible.

WARNING



1. For correct installation of vent system, read all of these instructions and refer to the vent pipe manufacturer's instructions.
2. Failure to use this venting system will void the manufacturer's warranty and may result in rapid deterioration of the venting system, a potential health hazard.
3. Faulty vent installation can allow toxic fumes to be released into living areas. This may cause serious bodily injury or property damage. Vent performance may also be affected by improper assembly.
4. Install separate vents for forced exhaust appliances and natural draft appliances. A common vent between natural draft and forced exhaust appliances may cause toxic gases to exhaust through the natural draft appliance rather than to outside air. Breathing exhaust gases will cause serious personal injury or death.

HORIZONTAL VENT INSTALLATION INSTRUCTIONS

- A. Boilers covered in this section are design-certified as CATEGORY III for venting, only when installed with manufacturer specified vent system components and installation practices.
- B. Install vent pipe beginning at the vent connector and work toward the vent cap.
- C. Vent pipe and fittings **MUST NOT** be routed into, through, or within any other vent, such as an existing masonry chimney or factory built chimney. (Recommended installation is shown in **figure 7a & 7b** page 14, unacceptable installation is shown in **figure 8** page 14).
- D. Vent pipe lengths. The maximum length is the combined length of straight horizontal and vertical runs, and the equivalent straight length of fittings. The required lengths for each boiler are as follows:

Vent Pipe Lengths				
Model	Vent Pipe Diameter	Vent Lengths		Equivalent Feet Per Fitting
		Maximum	Minimum	
DV50/DV100	3" (7.6cm)	30 ft (9.1m) w/condensate Tee & 2 elbows	2 ft (0.6m) w/1 elbow	5 ft (1.5m)
DV125	3" (7.6cm)	25 ft (7.6m) w/1 elbow	2 ft (0.6m) w/1 elbow	5 ft (1.5m)
DV150/200	4" (10.2cm)	30 ft (9.1m) w/1 elbow	2 ft (0.6m) w/1 elbow	5 ft (1.5m)
Example: 20 feet (6m) of vent pipe w/1 elbow is equivalent to 15 feet (4.6m) of vent pipe w/2 elbows. Note: condensate trap is not required on models DV150 thru 200.				

- E. Slope horizontal runs upwards not less than 1/4 inch/foot (21mm/m) from boiler to vent terminal.
- F. No portion of the vent pipe should have dips or sags where condensate could collect, see **figure 9** on page 14 for a typical vent system.
- G. Rigidly support vent pipe every 5 feet and at the elbows. Plumbers straps may be used.
- H. Clearances and enclosures. ALL vent pipe and fittings must be installed with appropriate air space clearances to combustibles. These air space clearances apply to indoor or outdoor vents, whether they are open, enclosed, horizontal or vertical or pass through floors, walls, roofs, or framed spaces. The appropriate air space clearances should be observed to joists, studs, subfloors, plywood, drywall, or plaster enclosures, insulated sheathing, rafters, roofing, and any other combustible material. The minimum air space clearance also applies to electrical wires and any kind of building insulation.
- I. Do not insulate or otherwise wrap vent pipe or fittings.
- J. For Horizontal runs maintain minimum clearance of 6 inches from vent pipe to any combustible material, electric wires, and building materials.

HORIZONTAL VENT INSTALLATION INSTRUCTIONS

Figure 7a - Vent Cap

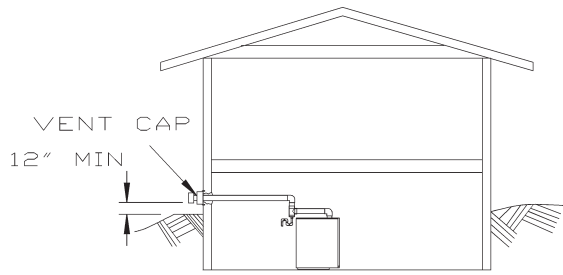

Figure 8

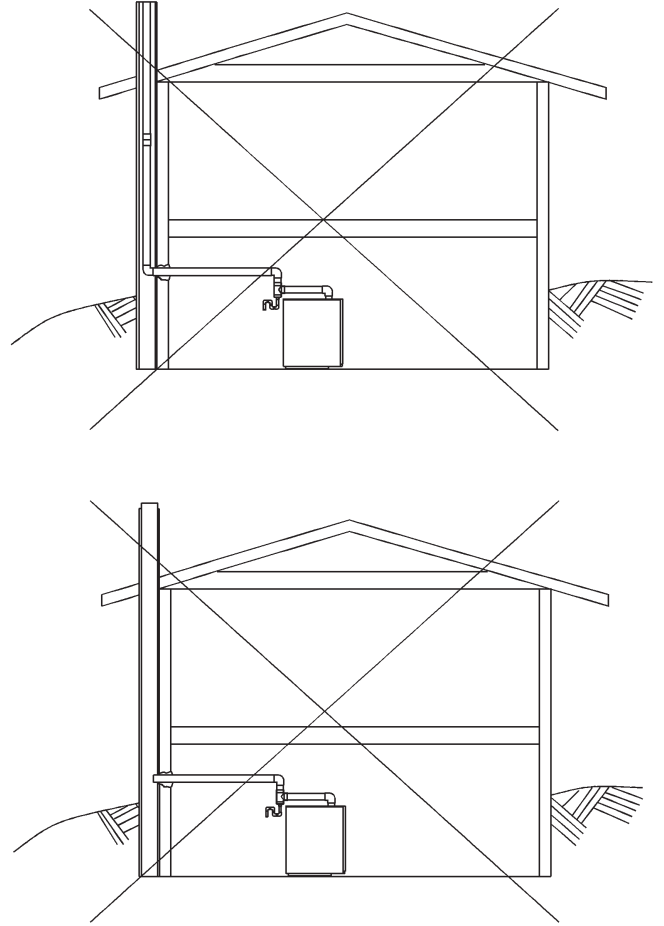

Figure 7b

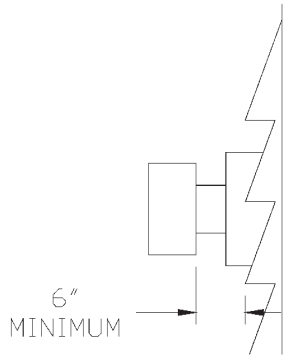

Figure 9

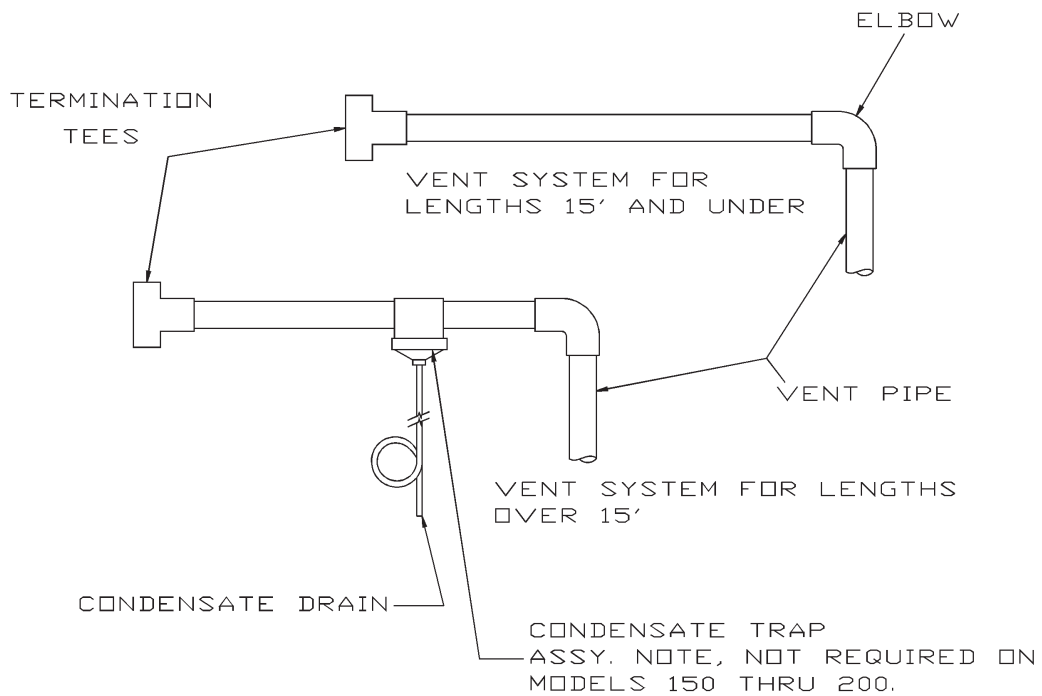
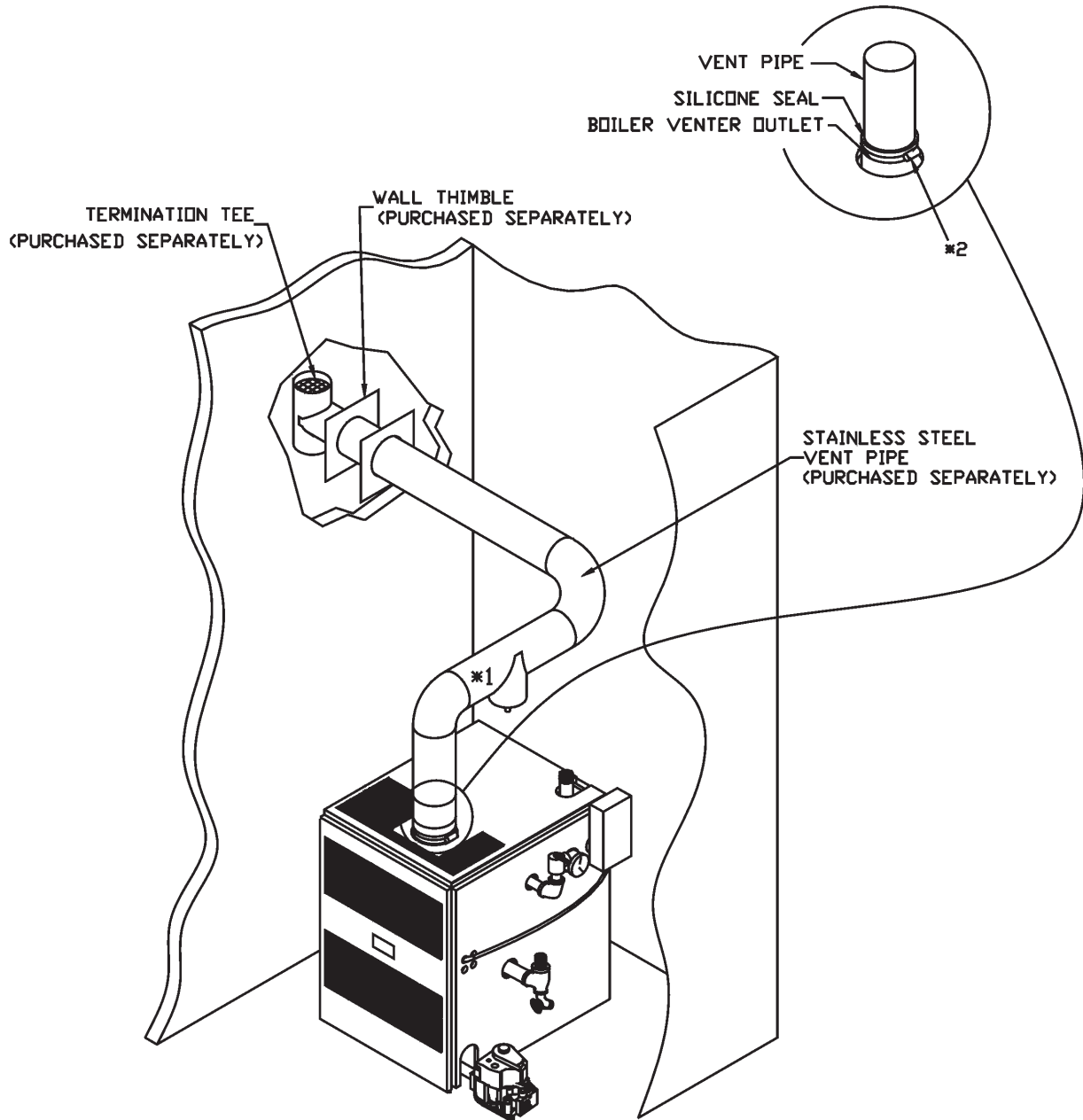

Figure 10 - Typical Installation



Notes:

1. Condensate tee/drain is only needed when horizontal vent lengths exceed 10 feet (3m).
2. Insert vent pipe in boiler venter outlet (vent adapter), apply silicone completely around edge of outlet and tighten clamp.

HORIZONTAL VENT INSTALLATION INSTRUCTIONS

Figure 11 - Flex-L® Star-34™ Vent Pipe Components

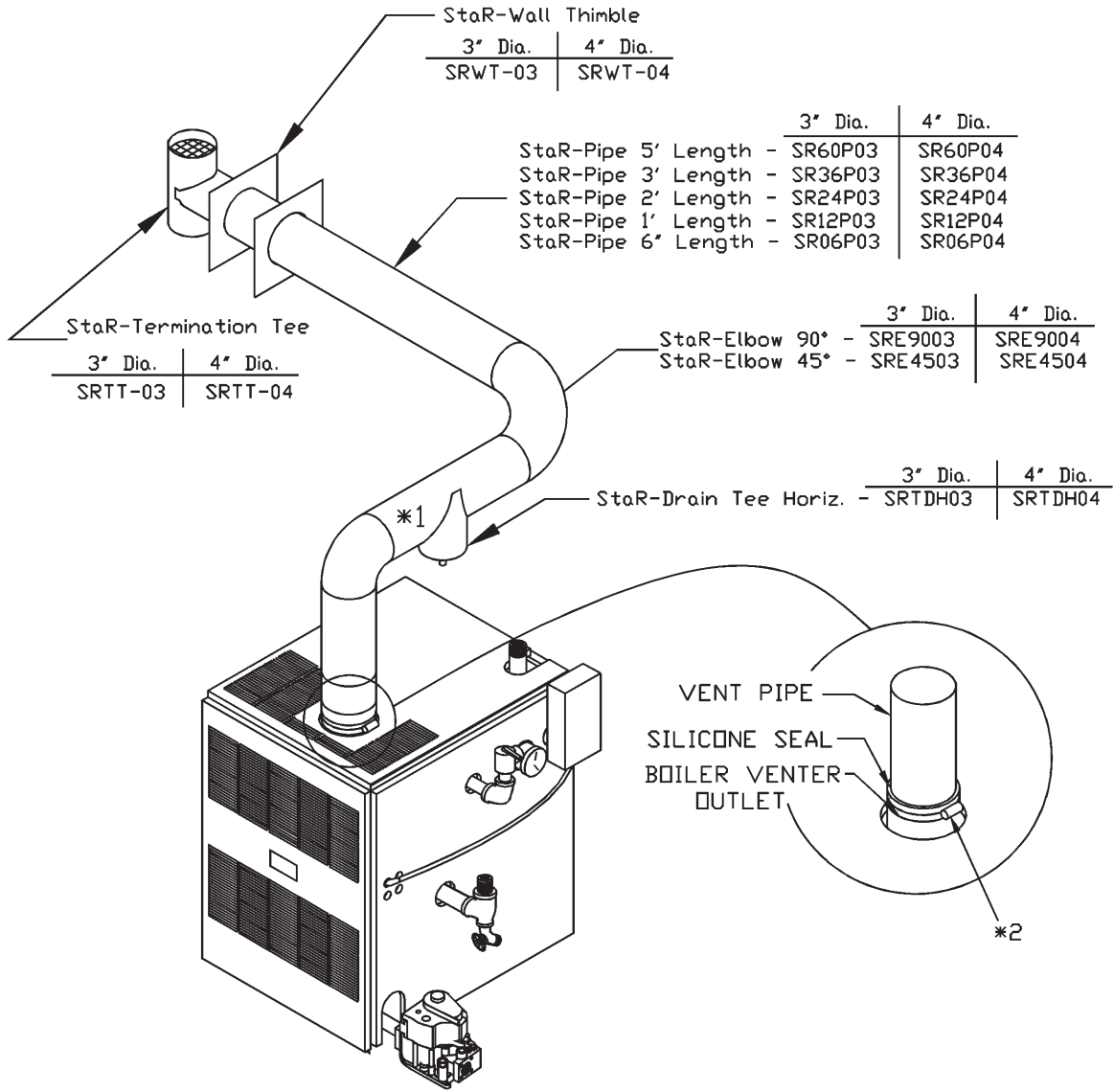

Notes:

1. Condensate tee/drain is only needed when horizontal vent lengths exceed 10 feet (3m).
2. Insert vent pipe in boiler venter outlet (vent adapter), apply silicone completely around edge of outlet and tighten clamp.

HORIZONTAL VENT INSTALLATION INSTRUCTIONS

Figure 12 - Heat Fab® Saf-T Vent™ Vent Pipe Components

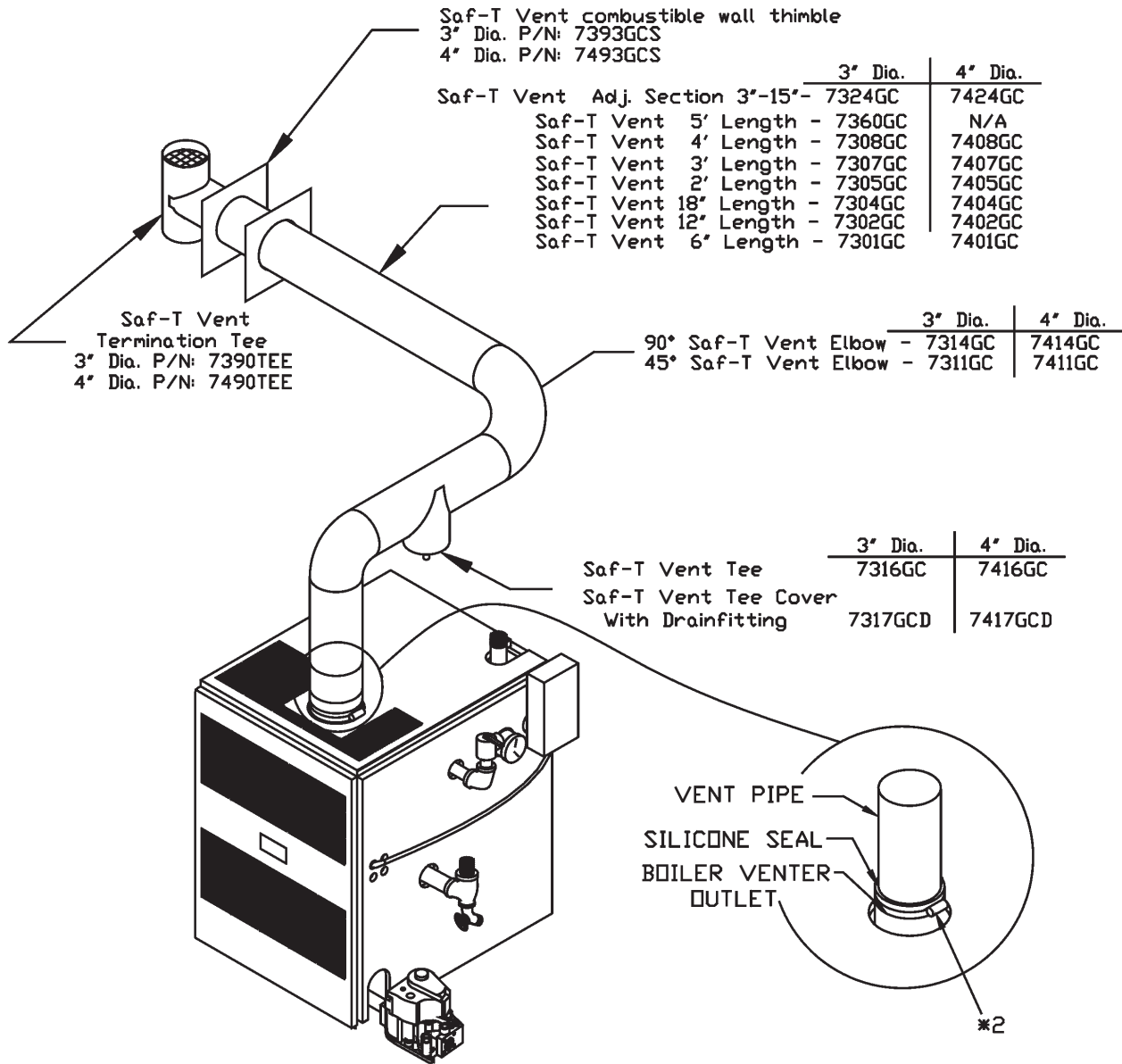

Notes:

1. Condensate tee/drain is only needed when horizontal vent lengths exceed 10 feet (3m).
2. Insert vent pipe in boiler venter outlet (vent adapter), apply silicone completely around edge of outlet and tighten clamp.

HORIZONTAL VENT INSTALLATION INSTRUCTIONS

Figure 13 - Z-Flex® Z-Vent™ Vent Pipe Components

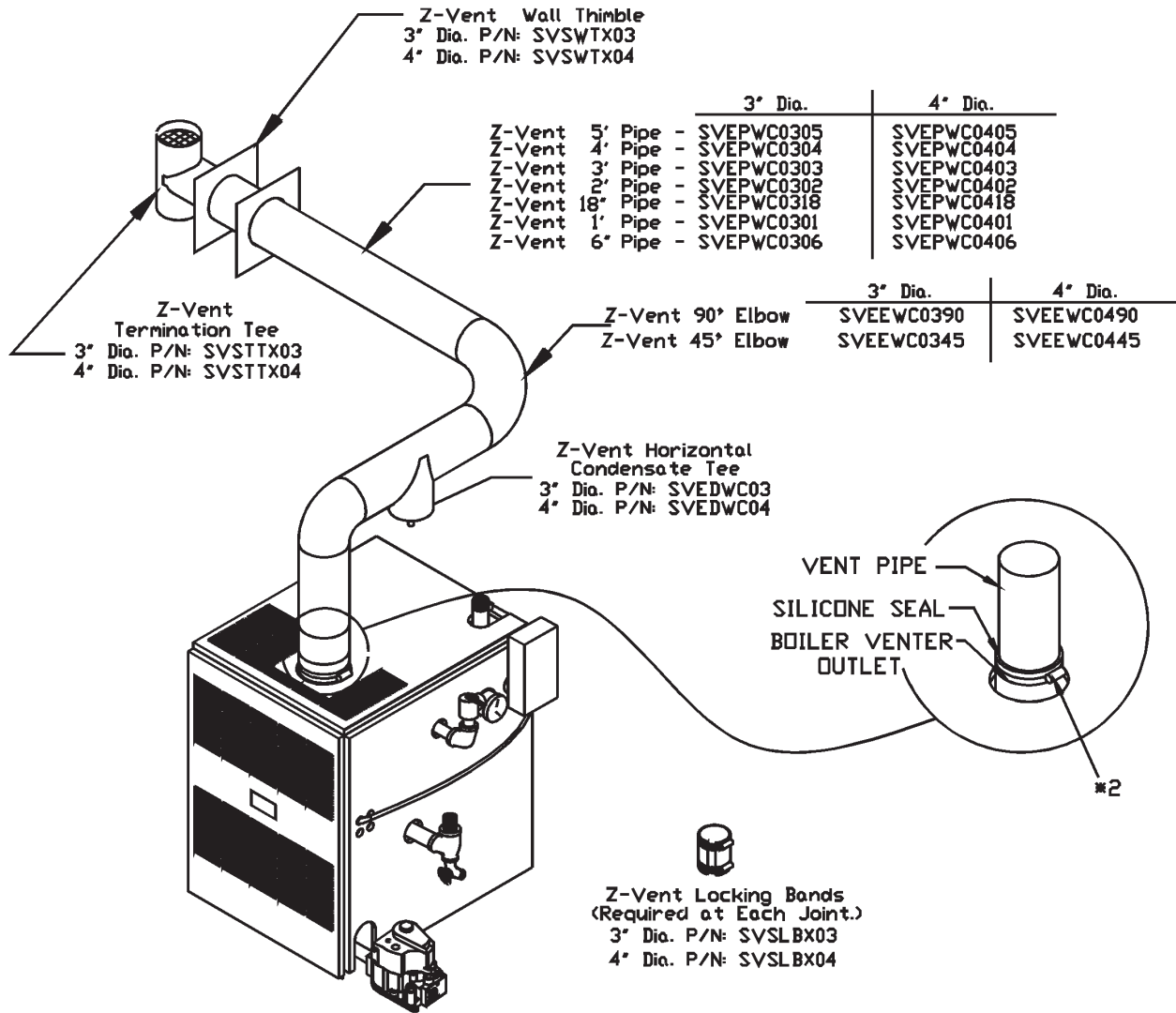

Notes:

1. Condensate tee/drain is only needed when horizontal vent lengths exceed 10 feet (3m).
2. Insert vent pipe in boiler venter outlet (vent adapter), apply silicone completely around edge of outlet and tighten clamp.

HORIZONTAL VENT INSTALLATION INSTRUCTIONS

Figure 14 - ProTech® FasNSeal™ Vent Pipe Components

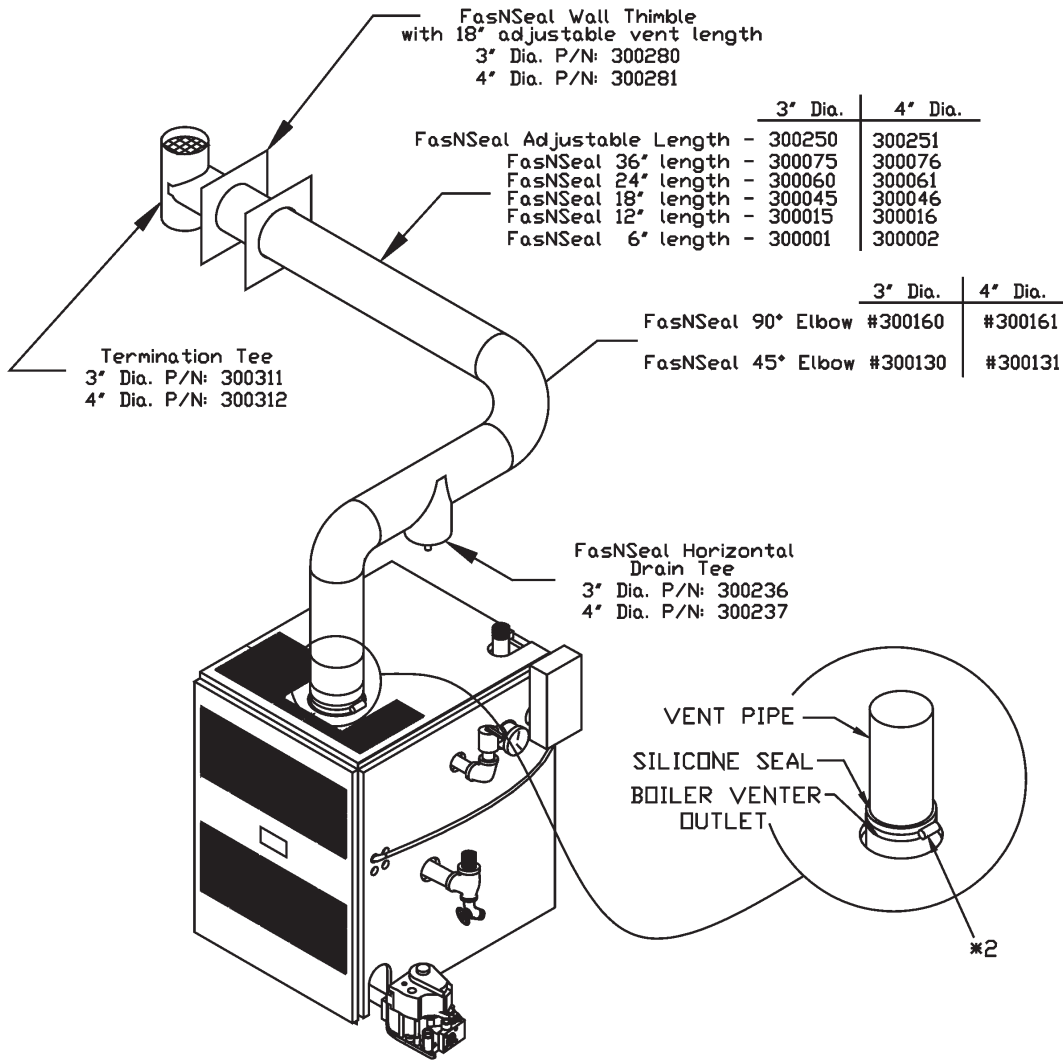

Notes:

1. Condensate tee/drain is only needed when horizontal vent lengths exceed 10 feet (3m).
2. Insert vent pipe in boiler venter outlet (vent adapter), apply silicone completely around edge of outlet and tighten clamp.

CONDENSATE DRAINS

- Condensate drain is not required on models DV150 thru 200.
- Do not place condensate drain where freezing may occur.
- Condensate drains are required when using condensate tee.
- Condensate drain fitting must be plumbed to sanitary drain for liquid condensate disposal. See **figure 15**.
- Condensate drain is plumbed with 3/8" (1 cm) inside diameter flexible tubing. Refer to "General Instruction For Seasonal Startup And Maintenance", in Installation, Operation and Maintenance Manual for maintenance recommendations and schedule.

1. Flexible Tubing Condensate Drain.

- In the vent, and close to appliance, install tee with run outlet.
- Install condensate drain in down outlet with high temperature adhesive.
- Connect condensate drain outlet to commercially available flexible tubing (minimum length 40"). Below drain outlet, make 6" diameter loop in 3/8" ID tubing, or 9" diameter loop in 5/8" ID tubing.
- Secure loop with plastic cable tie.
- Run other end of flexible tubing to sanitary drain. (Use a condensate pump if necessary)

LOCATING THE VENT TERMINATION

- At least 12 inches (30cm) above finished grade, or at least 12 inches (30cm) (18" (46cm) Canada) above the normally expected snow accumulation level in geographical areas where snow accumulates.
- 4 feet (1.2m) away from and not above any doors or windows.
- At least 3 feet (0.9m) above any forced air inlet located within 6 feet (1.8m) horizontally.
- At least 6 feet (1.8m) from combustion air intake of another appliance.
- Vent termination horizontally from, but in no case above or below, electric meters, gas meters, regulators, and relief equipment, or under porch.
 - USA 4 ft (1.2m)
 - Canada 6 ft (1.8m)
- Do not locate the vent termination in traffic areas like walkways, unless it is at least 7 feet above finished grade.
- Do not locate the vent termination too close to shrubbery as flue products may stunt or kill them.
- Some building materials may be affected by flue products expelled near unprotected surfaces. Sealing or shielding of exposed surfaces with a corrosion resistant material (such as aluminum sheet) may be required to prevent staining or deterioration.
- When installing vent cap secure it to a noncombustible wall or a combustible wall thimble. Refer to vent pipe manufacturers instructions.
- See the Federal Codes listed at beginning of these instructions for additional information on termination location.

Figure 15 - Condensate Drain

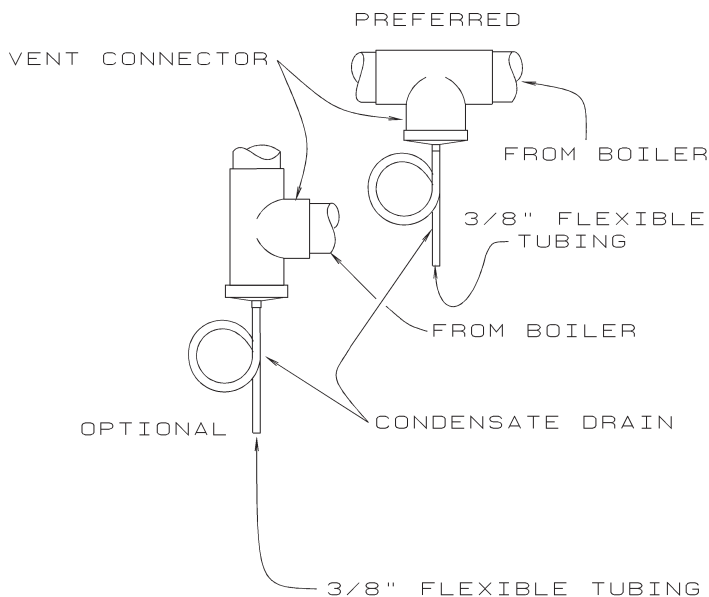
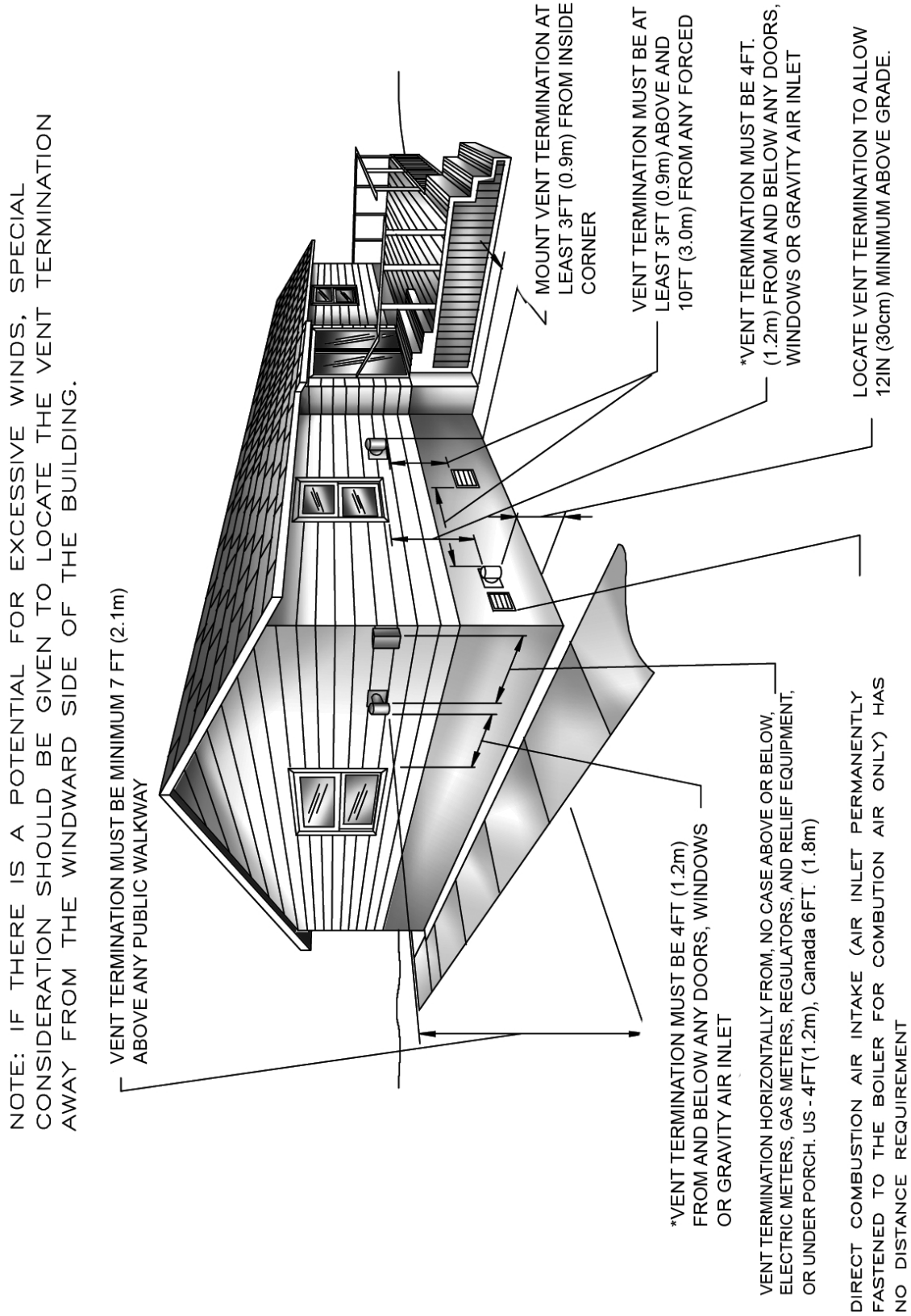

Figure 16 - Termination Clearances



PROVIDING FOR PROPER VENTING THROUGH THE ROOF

- Vent boiler making Ref. to NFGC section 2 & 10 and using these instructions and requirements of local utilities and other local code authorities.
- You must connect boiler to vent or factory-built chimney. Vent or factory-built chimney must meet recognized standard.
- Chimney lining method and material must comply with local code requirements.
- Use corrosion-resistant material meeting nationally recognized standards for vent construction.

WARNING



Inadequate vent or chimney could allow combustion products to collect in structure, resulting in injury or death.

WARNING



Vent this boiler separately from any appliance designed to burn solid fuel, particularly wood burning or coal burning appliances. Improper venting could allow combustion products to collect in the structure, resulting in injury or death.

A. VENTING CATEGORY

- Boilers covered by this manual are design-certified as CATEGORY I for venting. CATEGORY I Appliances have non-positive vent static pressure and rely on heat content of combustion products to vent. You may common vent CATEGORY I boilers.
- Boilers covered by this manual are also design certified as CATEGORY III for venting, only when they installed with manufacturer specified vent system components and installed practices. Ref. pages 12-21 for category 3 venting instructions.

B. DESIGN CONSIDERATIONS

- Avoid oversizing boiler for your application. Select a boiler model with a rated heating output close to the calculated heating load. This extends the firing period, decreasing the potential for condensate formation in the vent.
- Too small a vent cannot carry all combustion products outdoors. Too large a vent will not vent combustion products rapidly enough to avoid potential for condensation. Refer to pages 24 thru 27 for correct vent size.

- Vent height must be a minimum of six feet. Minimize vent connector horizontal runs to the extent possible for best performance.
- The designer must consider the building's orientation, answering these questions. (Ref. pages 24-27).
 - A. Will the vent terminate outside the building where its operation could be adversely affected by winds?
 - B. Could any adjacent buildings adversely affect vent operation?
 - C. Allowing for these factors can reduce the possibility of downdraft conditions.
- If your local experience indicates possible condensation problems, provide for draining and disposal of venting system condensate.

C. VENT SIZING

- Sometimes horizontal distance from boiler to vent or chimney is already given; this is known as horizontal vent connector run. Vent or chimney height is also usually given as Btuh input of gas appliances served by vent.
- Check these parameters to be sure venting system will work. Use approved engineering practices and part 7 & 10 of the latest revision of the (NFGC) National Fuel Gas Code, ANSI Z233.1/NFPA54.
- Use this venting addendum for single appliance venting and multiple appliance (common) venting. For multi story installations, refer to latest revision of National Fuel Gas Code ANSI Z233.1/NFPA 54.

D. VENT CONNECTOR

- Vent connectors must be made of noncombustible, corrosion resistant material capable of withstanding vent gas temperatures. They must be thick enough to withstand physical damage and be accessible for inspection, cleaning and replacement.
- Use Type B 1 vent connector in or through attics, crawl spaces, or other cold areas. Install thimbles that meet local codes when vent connectors pass through walls or partitions of combustible material.
- Keep vent connectors as short as possible by locating boiler as close as practical to vent or chimney. Avoid unnecessary turns or bends which create resistance to flow of vent gases. Adding an elbow adds resistance. For example, adding a 6" 90-degree elbow would be the equivalent of adding 20 feet of horizontal 6" pipe. (45-degree elbows have lower resistance than 90-degree elbows, and can work for most vent runs).
- If you join two or more vent connectors before they enter vertical vent or chimney, see **figure 17**, on page 24. Also refer to NFGC book, ANSI standards and NFPA book.

VERTICAL VENT PIPE INSTALLATION INSTRUCTIONS

- Do not connect boiler to any portion of vent system which operates under positive pressure. Positive pressure will result with CATEGORY III or IV appliances connected to vent.
- Do not connect vent connector to chimney flue serving a fireplace.

E. VERTICAL VENT OR CHIMNEY

- Vents and chimneys usually extend vertically with offsets not exceeding 45-degrees. Consider vent pipe runs more than 45-degrees as horizontal runs. Include their length in total horizontal run.
- Designer and installer must provide appropriately sized common vent for all appliances connected to it. (Ref. to figure 17, on page 17 or the latest revision of the NFGC)
- Connect this CATEGORY I boiler only to vent systems with other CATEGORY I appliances.

WARNING



Do not connect CATEGORY I boiler to vent system used by CATEGORY III and IV appliance. Do not connect it to vents with mechanical draft systems operating at positive pressure. Improper venting could allow combustion products to collect in structure during use, resulting in damage, injury or death.

F. CHIMNEY LINING

- Use suitably sized Type B1 vent liner or suitable corrugated liner. See **figure 17** page 24.

WARNING



Support vent liner in masonry chimney. Maintain at least 1" clearance on all sides to reduce possibility of condensate in vent. Condensate may cause vent to deteriorate allowing combustion products to collect in structure, which could result in injury or death. See **figure 17** page 24.

WARNING



Vent liner must not block opening where other appliance's vent connectors enter chimney. Blocked openings will cause combustion products to collect in structure, resulting in damage, injury or death.

WARNING



Do not use unlined masonry chimneys. These increase risk of condensate formation, which may cause chimney to deteriorate, allowing combustion products to collect in structure, resulting in damage, injury or death.

G. VENT TERMINATION

- Terminate all vertical vents with a listed vent cap or roof assembly unless local codes require otherwise.
- See vent cap or roof assembly manufacturer's instructions.
- Locate vent termination (vent cap or roof assembly) in an area without positive pressures or eddy currents. Eddy currents occur when air swirls over roof peaks. They cause down-drafts and adversely affect vent operation. See **figure 19** page 24.
- Some vent terminations or caps protect against eddy currents and down-drafts. Consult their manufacturer's instructions.
- Vent terminations or caps should usually be at least the same size as the vent. They may be larger if the installation warrants.
- Vent systems must end at least five feet above the highest gas appliance connection.
- Vent pipe must extend at least three feet above the point where it passes through the roof.
- Vent termination must be at least two feet higher than any portion of building within ten feet horizontal and vent termination must be at least two feet higher than roof peaks within ten feet horizontal. See **figures 20 and 21** page 24 .
- Some vent cap manufacturers offer vent caps that allow reduced clearances. Consult their instructions.

WARNING



Failure to properly terminate vent chimney systems could allow combustion products to collect in structure, resulting in injury or death.

- Terminate venting system at least three feet above any forced-air building inlet within ten feet. Consider doors, windows and gravity air building inlets. Locate vent termination at least four feet below, four horizontal feet from or one foot above any of these openings.

VERTICAL VENT PIPE INSTALLATION INSTRUCTIONS

Figure 17 - Vent Liner

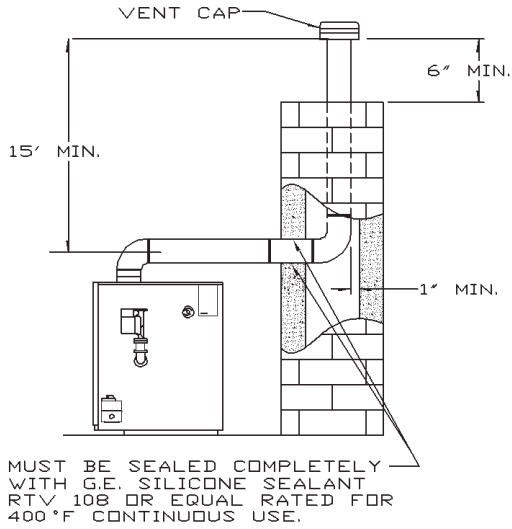

Figure 20 - Termination 10 ft (3m) Or Less From Ridge

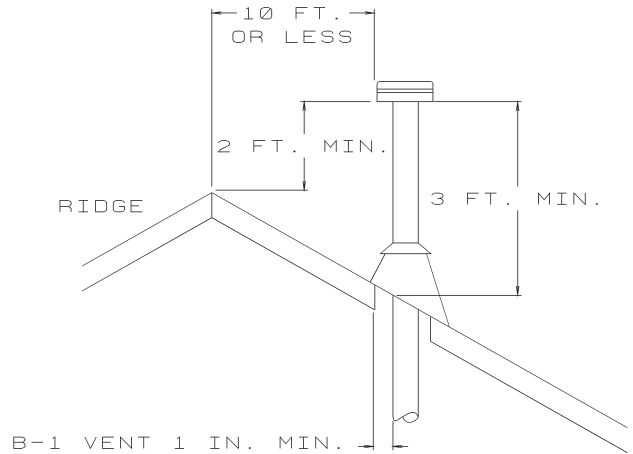

Figure 18 - Vent Liner Support In Masonry Chimney

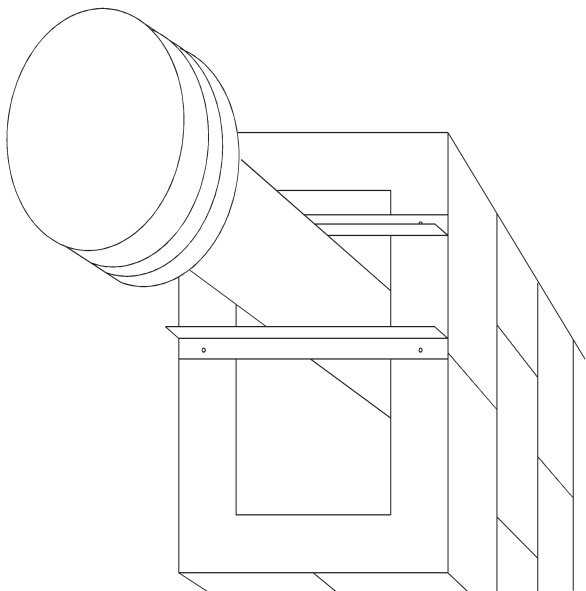

Figure 21 - Termination More Than 10 Ft (3m) From Ridge

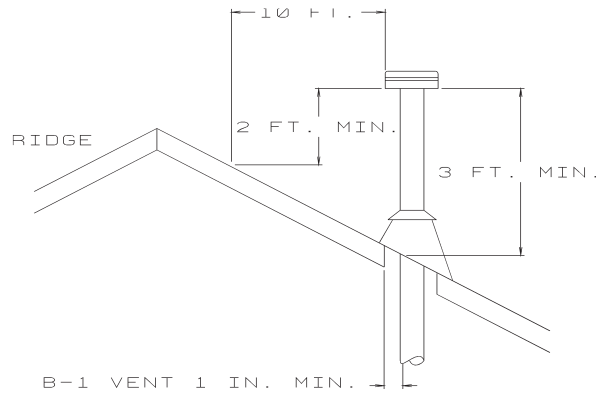

Figure 19 - Avoid areas of Wind Currents

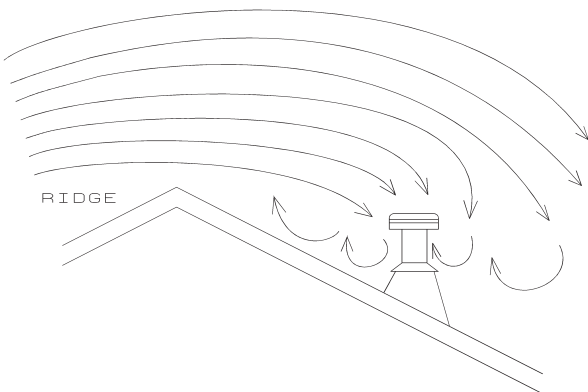

Table 4 Roof Pitch Chart

Roof Pitch	Height Above Roof	Brace
Flat to 7/12	1.0 ft (0.3m)	
Over 7/12 to 8/12	1.5 ft (0.5m)	
Over 8/12 to 9/12	2.0 ft (0.6m)	
Over 9/12 to 10/12	2.5 ft (0.8m)	Brace to Roof at top
Over 10/12 to 11/12	3.3 ft (1.0m)	
Over 11/12 to 12/12	4.0 ft (1.2m)	
Over 12/12 to 14/12	5.0 ft (1.5m)	Brace to Roof at Top and Mid Point
Over 14/12 to 16/12	6.0 ft (1.8m)	
Over 16/12 to 18/12	7.0 ft (2.1m)	
Over 18/12 to 8/12	7.5 ft (2.3m)	
Over 20/12 to 21/12	8.0 ft (2.4m)	

H. INSTALLATION

- Vent Adaptor.
 - A. Attach vent adaptor at draft inducer collar. See **figure 24** on page 27. Use Kit # 56111101 for DV 50-125 and Kit # 56111102 for DV 150-200, or equivalent.

WARNING

Make sure that all vent pipe and connectors are secured because unsecured vent pipe connections may loosen. This can allow combustion products to collect in the structure, resulting in injury or death.

- Vent Connector.
 - A. Install vent connectors without any dips or sags. Slope them upward from boiler at least 1/4" per foot. To prevent sagging, at each joint support vent connectors and horizontal portions using hangers, straps or equivalent. Seal all connections where vent connectors enter chimney. See **figure 17** on page 24.
- Vertical Vent.
 - A. Install vent materials following their listing terms, manufacturer's instructions, these instructions and local codes. A gas vent passing through a roof must extend through roof flashing, jack or thimble. It must terminate above the roof surface. See **figures 20 & 21**.

I. EXISTING VENT CONSIDERATIONS

Masonry chimneys previously used for venting equipment should be suitable per NFGC standard. Also provide an accessible clean out per the latest revision of the NFGC, ANSI Z223.1, AND NFPA 54.1

1. Vent Inspection
 - A. Make sure existing vent or chimney is the proper size and construction for appliances that will use it. The best way to do this is to size as if it were a new installation. Compare the existing vent to your calculations and make necessary corrections.
 - B. Examine vent or chimney cleanouts to make sure they remain tightly closed when not in use. Make sure vent or chimney passageway is clear and free of obstructions. Look for evidence of condensate or deterioration in vent or chimney. Either of these means an inadequate vent.
 - C. If you find an inadequate vent or chimney, do not leave it as is. Repair or replace it. A new vent must meet these instructions and the latest revision of the National Fuel Gas Code ANSI Z223.1/NFPA 54.

Figure 22 - Vertical Venting Installation for Type B Vent*

MODEL	D1	D2 MIN	D2 MAX
DV50	4"	4"	5"
DV100	4"	4"	6"
DV125	4"	4"	8"
DV150 - 200	4"	5"	8"

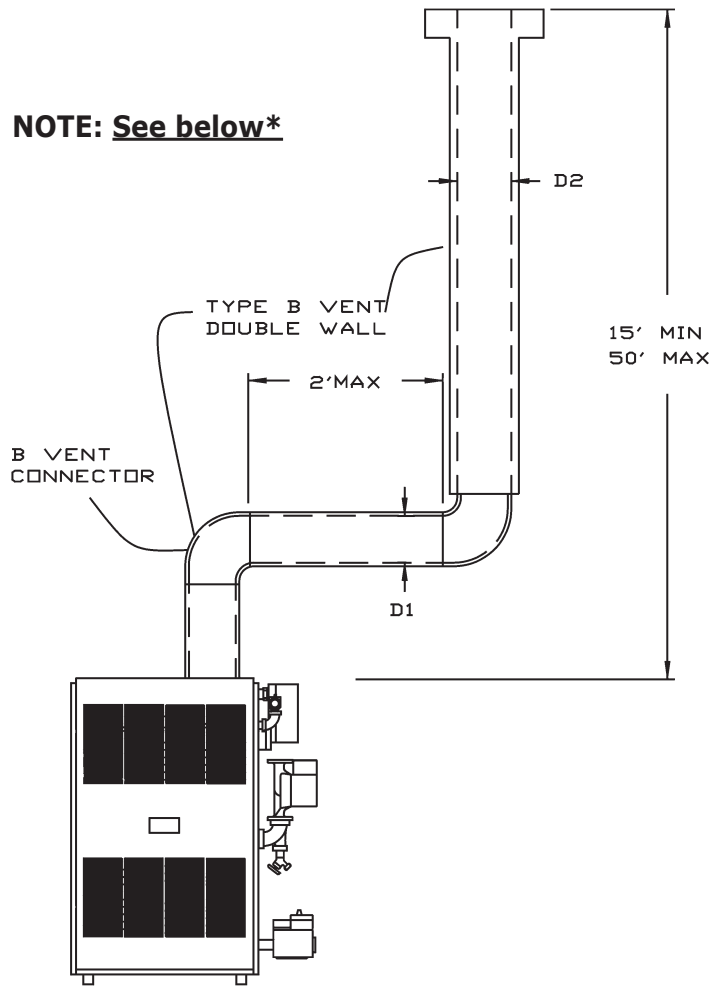

NOTE: See below*

*Information contained in this figure is only one of many possible vertical venting configurations. Follow appropriate sections of NFGC for proper venting practice for category 1 appliances.

VERTICAL VENT PIPE INSTALLATION INSTRUCTIONS

Figure 23 - Vertical Venting Installation for Type B Vent W/Natural Draft Water Heater (40,000BTU/Hr)*

MODEL	D1	D2 MIN	D2 MAX
DV50	4"	4"	4"
DV100	4"	5"	6"
DV125 & 150	4"	6"	8"
DV175 & 200	4"	7"	8"

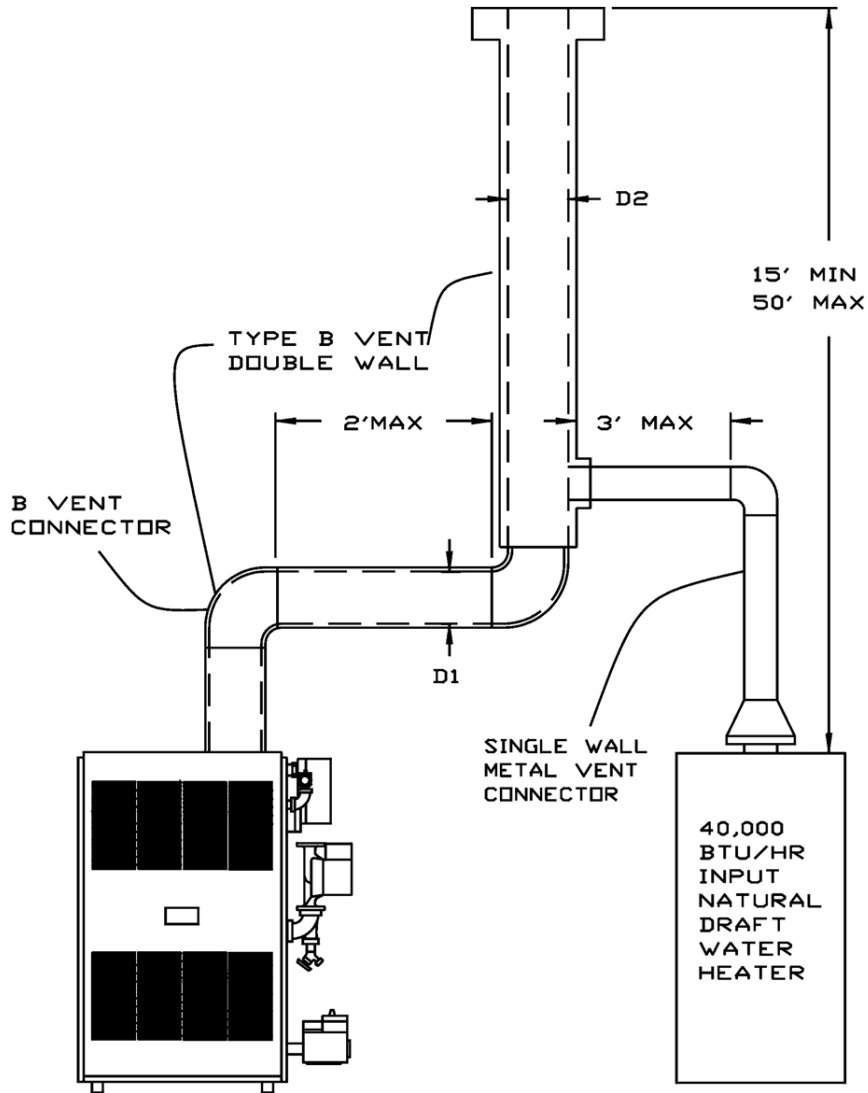

NOTE:

* Information contained in this figure is only one of many possible vertical venting configurations. Follow appropriate sections of NFGC for proper venting practice for category 1 appliances.

Figure 24 - Category I Vent Using Hart & Cooley Type B Gas Vent or Equivalent

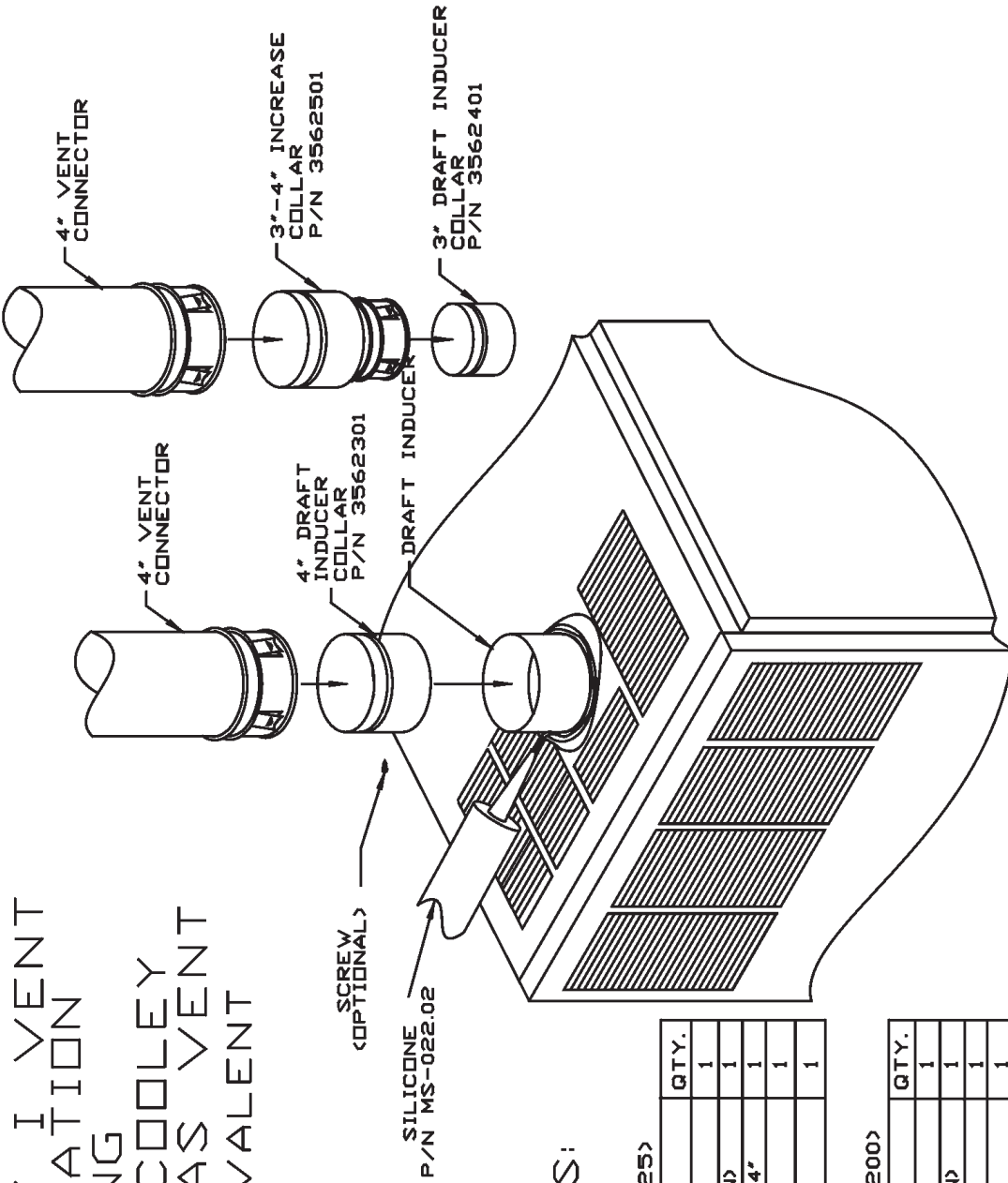

CATEGORY I VENT
INSTALLATION
USING
HART & COOLEY
TYPE B GAS VENT
OR EQUIVALENT

KIT CONTENTS:

KIT # 5611101
<MODEL NUMBERS 50 THRU 125>

PART NO.	DESCRIPTION	QTY.
MS-022.02	SILICONE	1
PK-022.01	CARTON <NOT SHOWN>	1
3562501	VENT INCREASE 3"-4"	1
3652401	INDUCER COLLAR 3"	1
37613301	INSTRUCTIONS	1

KIT # 5611102
<MODEL NUMBERS 150 THRU 200>

PART NO.	DESCRIPTION	QTY.
MS-022.02	SILICONE	1
PK-022.01	CARTON <NOT SHOWN>	1
3652301	INDUCER COLLAR 4"	1
37613301	INSTRUCTIONS	1

CAUTION

WHAT TO DO IF YOU SMELL GAS

- Do not try to light any appliance.
- Do not touch any electrical switch; do not use any phones in your building.
- Immediately call your gas supplier from a neighbor's phone. Follow gas supplier's instructions.
- If you cannot reach your gas supplier, call the fire department.

General

- Use piping materials and joining methods acceptable to authority having jurisdiction. In absence of such requirements:
 - USA - National Fuel gas Code, ANSI Z223.1/NFPA 54
 - Canada - Natural Gas and Propane Installation Code, CAN/CSA B149.1
- Size and install gas piping system to provide sufficient gas supply to meet maximum input at not less than minimum supply pressure. See Table 6.
- Support piping with hooks straps, bands, brackets, hangers, or building structure components to prevent or dampen excessive vibrations and prevent strain on gas connection. Boiler will not support piping weight.
- Use thread (joint) compound (pipe dope) suitable for liquefied petroleum gas.
- Install field sourced manual main shutoff valve, ground joint union, and sediment trap upstream of gas valve. See **figure 25**.

Figure 25 - Gas Piping

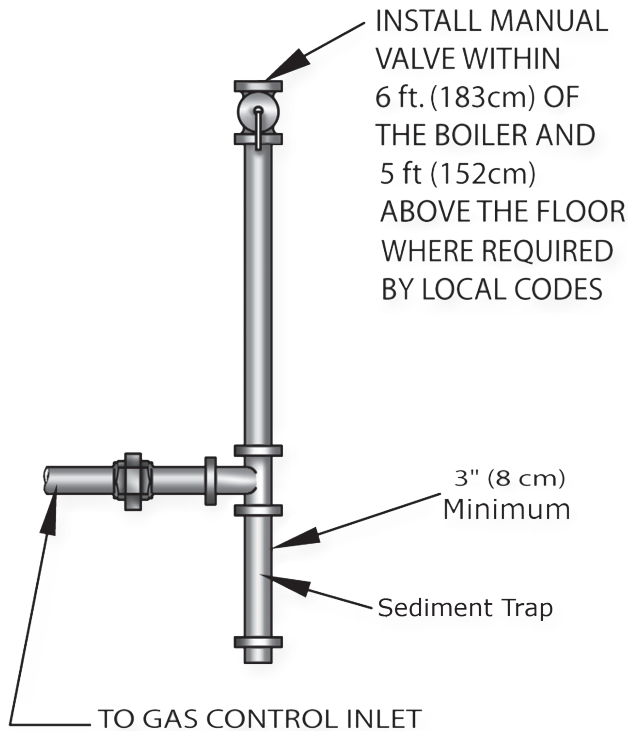

Table 6	Natural Gas	Propane
Min. Supply Pressure	5" w.c.	11" w.c.
Max. Supply Pressure	13.5" w.c.	13.5" w.c.
Manifold Pressure	3.5" w.c.	10.5" w.c.

DANGER

Fire Hazard. Do not use matches, candles, open flames, or other methods providing ignition source. Failure to comply will result in death or serious injury.

Leak Check Gas Piping

Pressure test boiler and gas connection before placing boiler in operation.

- Pressure test over 1/2 psig (3.5 kPa). Disconnect boiler and its individual gas shutoff valve from gas supply system.
- Pressure test at 1/2 psig (3.5 kPa) or less. Isolate boiler from gas supply system by closing manual gas shutoff valve.
- Locate leakage using gas detector, noncorrosive detection fluid, or other leak detection method acceptable to authority having jurisdiction. Do not use matches, candles, open flames, or other methods providing ignition source.
- Correct leaks immediately and retest.

MAXIMUM CAPACITY OF PIPE IN CUBIC FEET OF GAS/HOUR
(Gas Pressure = 0.5 psig or less, Pressure Drop = 5 in. w/c)

Length of Pipe (Feet)	Table 5 Nominal Iron Pipe Size			
	1/2"	3/4"	1"	1 1/4"
10	175	360	680	1400
20	120	250	465	950
30	97	200	375	770
40	82	170	320	660
60	66	138	260	530
80	57	118	220	460
100	50	103	195	400

For additional information refer to the National Fuel Gas Code Handbook.

ELECTRICAL WIRING

- When installed boiler must be electrically bonded to ground in accordance with the requirements of the authority having jurisdiction or, in the absence of such requirements, with the National Electrical code, ANSI/NFPA 70, and/or the Canadian Electrical Code Part 1, CSA C22.1, Electrical Code.
- Install fused disconnect switch between boiler and meter at convenient location.

* Not all components listed are used in all control systems.
Hot water control and intermittent ignition wiring for boilers with fail safe relay. See **figure 26**.





NOTES:

- * Switches are shown in position during the heating cycle.
- * If any of the original wiring supplied with the boiler is replaced it must be replaced with like wire size and type of insulation or equivalent.

COMPONENT AND Wire CODING Keys

The keys that follow pertain to the **HOT WATER CONTROL AND INTERMITTENT IGNITION WIRING** diagrams.

COMPONENT KEY	CODING
Thermostat (millivolt)	TH-1
Thermostat (24 Volt)	TH-2
Thermostat (Line Voltage)	TH-3
Transformer (120V/24V 40VA)	TR-1
Transformer (120V/24V 50VA)	TR-2
24 Volt Gas Valve	LGV
24 Volt Gas Valve	LGV-1
Pressure Switch	PS
Manual Reset Pressure Sw.	MR-PS
Control Terminal	○
Relay Coil	1K
Relay Contacts	1K1
Relay Contacts	1K2
Limit Switch	LS
Manual Switch	MS
Circulator	CIR
Energy Cut-Off	ECO
Pilot Safety Coil	PSC
Wire Connection	●
Low Water Cut Off	LWCO
Electric Water Feeder	EWF
Power Generator	PG
Roll-Out Switch	RSW

WIRING CODE KEY	
	LINE VOLTAGE BY FACTORY
	LOW VOLTAGE BY FACTORY
	LINE VOLTAGE BY INSTALLER
	LOW VOLTAGE BY INSTALLER

ELECTRICAL WIRING

THERMOSTAT INSTALLATION

1. Thermostat should be installed on an inside wall about four feet above the floor.
2. Never install a thermostat on an outside wall.
3. Check thermostat operation by raising and lowering thermostat setting as required to start and stop the burners.
4. Instructions for the final adjustment of the thermostat are packaged with the thermostat (adjusting heating anticipator, calibration, etc.)

THINGS TO AVOID WHEN LOCATING THERMOSTATS	
DEAD SPOTS:	
Corners and alcoves	Behind doors
COLD SPOTS:	
Concealed pipes or ducts	Concealed pipes
	Fireplace or chimney
Stairwells - drafts	TV sets
	Radios
Unheated rooms on other side of wall	Lamps
	Direct sunlight
Outside walls	Kitchens

LIGHTING INSTRUCTIONS

WARNING



If you do not follow these instructions exactly, a fire or explosion may result causing property damage, personal injury or loss of life.

Before operating, verify boiler and system are full of water to minimum pressure (this is usually 12 psi on most systems) and system is vented of air. See operating and lighting instructions.

FOR YOUR SAFETY READ BEFORE OPERATING

WARNING



If these instructions are not followed exactly, a fire or explosion may result causing property damage, personal injury or loss of life.

- A. This appliance is equipped with an ignition device which automatically lights the pilot. Do not try to light the pilot by hand.
- B. BEFORE OPERATING smell all around the appliance area for gas. Be sure to smell next to the floor because some gas is heavier than air and will settle on the floor.

WHAT TO DO IF YOU SMELL GAS

- Do not try to light any appliance.
- Do not touch any electrical switch. Do not use any phone in your building.
- Immediately call your gas supplier from a neighbor's phone. Follow the gas supplier's instructions. If you cannot reach your gas supplier, call the fire department.

- C. Use only your hand to move the system control switch. Never use tools. If the switch will not move by hand, don't try to repair it, call a qualified service technician. Force or attempted repair may result in a fire or explosion.

WARNING



Force or attempted repair may result in a fire or explosion.

- D. Do not use this appliance if any part has been under water. Immediately call a qualified service technician to inspect the appliance and to replace any part of the control system and any gas control which has been under water.

LIGHTING INSTRUCTIONS

LIGHTING PROCEDURE FOR BOILER WITH

INTERMITTENT PILOT SYSTEM

1. **STOP!** Read the safety information in the user's information manual.
2. Set thermostat to lowest setting.
3. Turn off all electric power to the appliance.
4. This appliance is equipped with an ignition device which automatically lights the burner. DO NOT try to light the burner by hand.
5. Turn the gas control knob clockwise ↻ to "OFF". See **figure 27**.
6. Wait five (5) minutes to clear out any gas. Then smell for gas, including near the floor. If you smell gas, **STOP!** Follow "What To Do If You Smell Gas" in the safety information section. If you don't smell gas, go on to the next step.
7. Turn the gas control knob counterclockwise ↺ to "ON".
8. Turn on all electrical power to the appliance.
9. Set the thermostat to desired setting.
10. If the appliance will not operate, follow the instructions "To Turn Off Gas To Appliance" and call your service technician or gas supplier.

TO TURN OFF GAS TO APPLIANCE

1. Set the thermostat to lowest setting.
2. Turn off all electric power to the appliance if service is to be preformed.
3. Turn gas control knob clockwise ↻ to "OFF" Do Not Force.

Figure 27 - Intermittent Pilot System

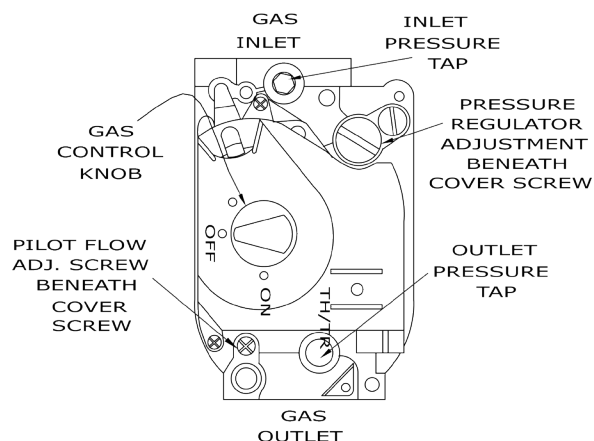

SEQUENCE OF OPERATION

On a call for heat:

1. The thermostat will actuate, completing the circuit between terminals T and T.
2. The R8222C relay coil will energize thus pulling in the relay contacts.
3. The circulator starts and power is switched to the limit. If limit circuit is closed the venter motor and TF-2 transformer are energized.
4. The venter motor starts and develops static pressure.
5. When the static pressure is reached the pressure switch pulls in completing the circuit between TF-2 and the intermittent ignition control.
6. The intermittent ignition control opens the pilot valve and ignites pilot. After pilot is proven the main burner will ignite.
7. In the event the boiler water temperature exceeds the high limit setting the power will be interrupted to the venter motor, and TF-2 thus interrupting power to the ignition system. Power will remain off until the water temperature drops below the high limit setting. The circulator will continue to operate under this condition until the thermostat is satisfied.
8. Should the air flow (static pressure) be interrupted (example blocked flue, etc.), the pressure switch will sense a drop in pressure, opening the circuit between the ignition system and TF-2. The venter motor will continue to operate until static pressure is reached or thermostat is satisfied.
9. In the event the flow of combustion products through any part of the boiler flueway becomes blocked, a flame safety roll-out switch will shut off the main burners. If this condition occurs, do not attempt to place the boiler back operation.
10. When the thermostat is satisfied power is interrupted to the relay coil and the relay drops out cutting power to the circulator, venter motor, and TF-2.

GENERAL INSTRUCTION FOR SEASONAL STARTUP & MAINTENANCE

It is suggested that a qualified service agency be employed to make an annual inspection of the boiler and the heating system. They are experienced in making the inspection outlined below.

In the event repairs or corrections are necessary they can make the proper changes for safe operation of the boiler.

CAUTION



Label all wires prior to disconnection when servicing controls. Wiring errors can cause improper and dangerous operation.

Verify proper operation after service.

If the venter has oil cups, lubricate venter motor once a month during the heating season with a few drops of non-detergent motor oil (SAE 20 or 30). Replace the rubber plugs when finished.

CAUTION



Do not over oil.

BEGINNING OF EACH HEATING SEASON

1. Before seasonal start-up, it is highly advisable to have a certified service agency inspect the system:
 - A. Check the boiler for soot and scale build up in the flues.
 - B. Clean the burners.
 - C. Check the gas input rate to maintain high operating efficiency.
2. The service agency should make certain the system is filled with water to minimum pressure (approximately 12 pounds per square inch) and open air vents (if used) to expel any air that may have accumulated in the system.
3. Check automatic air vents for leakage.
4. Inspect venting system at the start of each heating season. Check the pipe from the boiler for signs of deterioration and sagging joints. Repair if necessary. Remove the vent pipe from the boiler and check for obstructions.
5. Clean condensate tee & trap. Periodic cleaning of the condensate collection system is required. When a condensate collection system is installed in a venting system, it is recommended that the cleaning become a part of the annual servicing.

Procedure for cleaning condensate system:

- A. Remove tubing from condensate tee.
 - B. Empty all liquid from tubing.
 - C. Rinse tubing inside & out in a sink with water.
 - D. If tubing cannot be cleaned inside, the tubing should be replaced with the same type and size of tubing.
 - E. Replace tubing as described in **figure 28**. (Fill trap with water.)
 - F. Visually inspect entire piping system and if any leaks appear, have them repaired as soon as possible. DO NOT use petroleum based stop leak compounds.
6. Check venter assembly static pressure as follows:
 - A. With the boiler off, disconnect the white compression fitting on the pressure switch.
 - B. Connect a slope manometer to the compression fitting with additional tubing.
 - C. Turn the boiler on and read suction pressure on the manometer. Reading should be negative (-) $.55 \pm .05$ inches of water column or higher for the 50B thru 150B and negative (-) $.65 \pm .05$ inches of water column or higher for the 200B.
 7. If static pressures are not at the minimum allowable level (listed above), check vent pipe for obstructions.

Figure 28 - Condensate Tubing

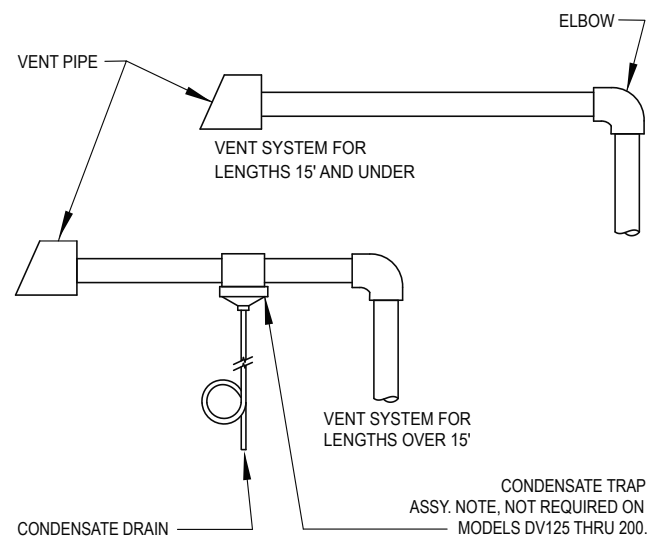

8. The following procedure should be followed to clean and check the boiler flue passageways:
 - A. Remove the burners from the combustion chamber by raising the burners up from the manifold orifices and pulling toward the front of the boiler. See **figure 29**.
 - B. Disconnect the vent pipe from the vent adapter.
 - C. Remove the top jacket panel. See **figure 30**.
 - D. Disconnect the white compression fitting from the pressure switch.
 - E. Disconnect venter wires from relay.
 - F. Remove the flue collector and venter from the boiler castings by loosening the hold-down bolts located on each side of the collector. See **figure 31**.
 - G. Visually inspect the venter assembly for any unusual wear or dirt build up. Clean with vacuum if necessary.
 - H. Place a sheet of heavy paper or similar material over the bottom of the combustion chamber and brush down the flue passageways. The soot and scale will collect on the paper and is easily removed with the paper.
 - I. Vacuum out base and flueways and reassemble the boiler in reverse order.
 - J. Seal flue collector and vent adapter with high temperature silicone. (+400°)
 - K. Start boiler to ensure proper operating condition.
9. Keep the area around the boiler clean and free of combustible materials such as gasoline, paints, paint thinner and other such flammable vapors and liquids.
10. The free flow of combustion and ventilating air to the boiler and boiler room must not be restricted or blocked.
11. Some circulators require periodic servicing. These circulators usually have oil cups or openings at each end of the motor and one for the shaft bearing. Put about one teaspoon of SAE 20 or 30 non-detergent motor oil in each opening twice per year. DO NOT OVER OIL. Follow the manufacturers instructions attached to the circulator. When oil cups or holes are not provided, bearings are either permanently lubricated or water lubricated.
12. Visually check the main burners and pilot flame at the start of each heating season and again midway through the season.
 - A. Check the burner throats and burner orifices for lint and dust obstructions. See **figure 31**.
 - B. The main burner flame should have a well defined inner blue mantel with a lighter blue outer mantel. See **figure 32**.
 - C. The pilot flame should envelop $\frac{3}{8}$ to $\frac{1}{2}$ inch of the tip of the pilot sensing device. See **figure 33**.

Figure 29 - Combustion Chamber

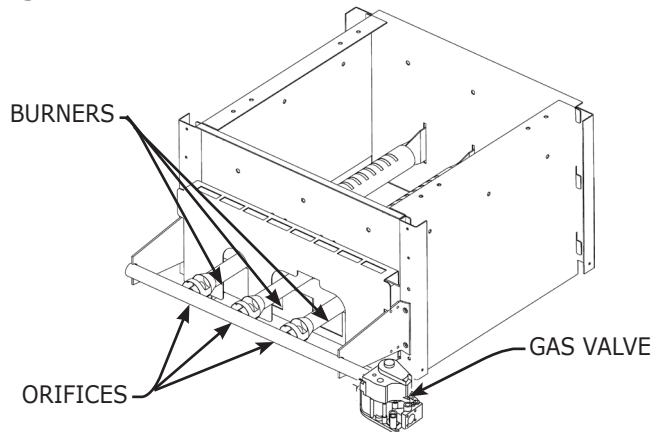
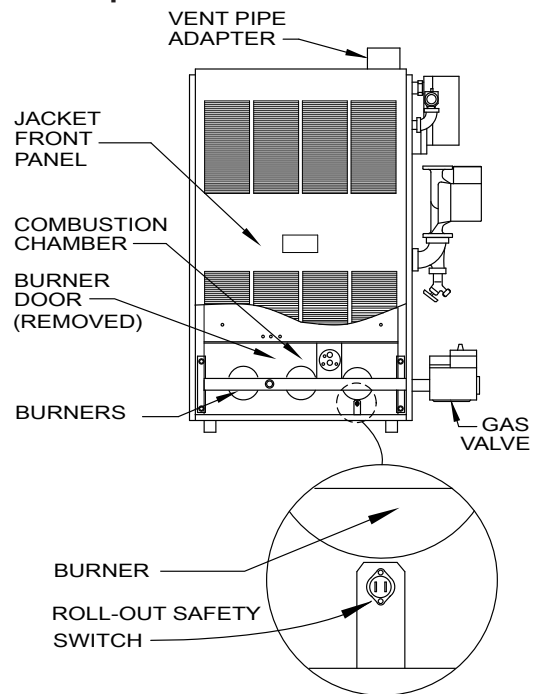

Figure 30 - Top Jacket Panel



(Location may vary by model)

Figure 31 - Burners

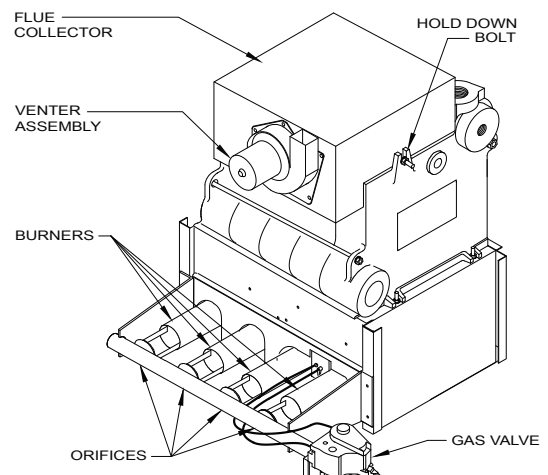
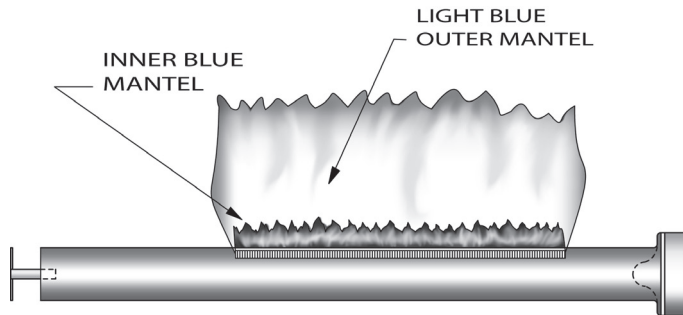

Figure 32 - Main Burner Flame



The main burner flame should form a sharp blue inner mantel with no yellow.

Figure 33 - Pilot Flame

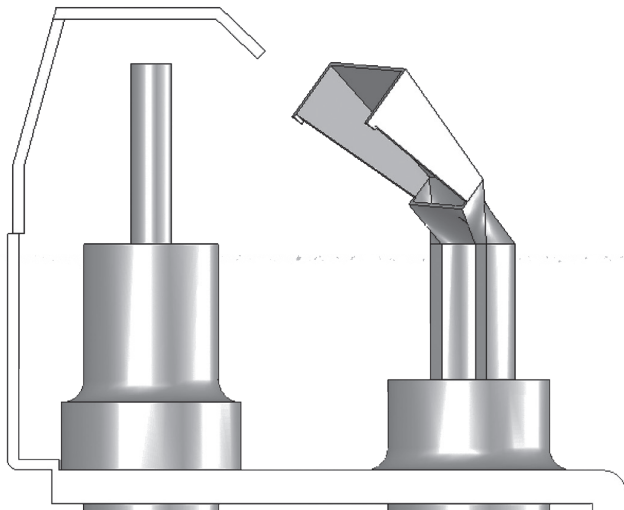
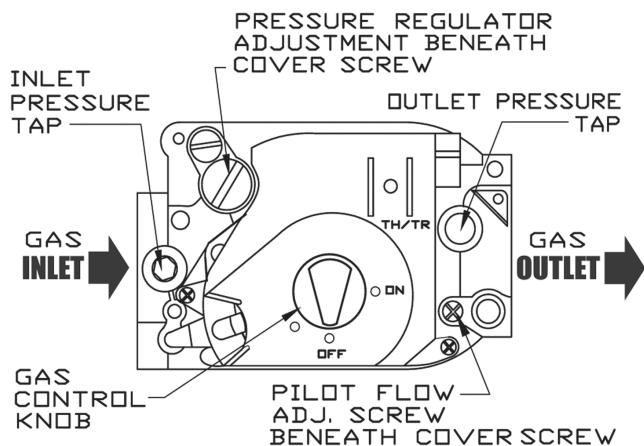

Figure 34 - Gas Valve



13. Adjusting the pilot flame:

- A. Remove the pilot adjustment cover screw.
- B. Turn inner screw (adjustment screw) clockwise ↻ to decrease and counterclockwise ↻ to increase the pilot flame. See **figure 34**.
- C. After adjustment, be sure to replace cover screw to prevent possible gas leakage.
- D. The main burners and the pilot burner should be checked for signs of corrosion or scale build up.
- E. Clean main burners and pilot burner with a steel bristle brush.

CHECK GAS INPUT RATE TO BOILER

1. Maximum permissible gas supply pressure must not be higher and minimum supply pressure must not be lower than what is specified on the rating plate.
2. To check for proper flow of natural gas to boiler using the gas meter, proceed as follows:
 - A. Turn off the gas supply to all other appliances, except the boiler.
 - B. With the boiler operating, determine the flow of gas through the meter for two minutes and multiply by 30 to get the hourly rate (in cubic feet).
 - C. Divide the input rate shown on the rating plate by the heating value of the gas as obtained from the local gas company. This will determine the number of cubic feet of gas required per hour.
 - D. If minor adjustment is necessary, adjust the pressure regulator on the combination gas control. Increase or decrease manifold pressure to obtain gas input required as described on the rating plate. To increase, turn the regulator adjusting screw clockwise ↻ or counterclockwise ↻ to decrease pressure, see **figure 38**. The manifold pressures are taken at the outlet side of the gas valve.
 - E. Relight all the other appliances turned off in step "a." above. Be sure all pilot burners are operating.

REPLACEMENT PARTS

PILOT

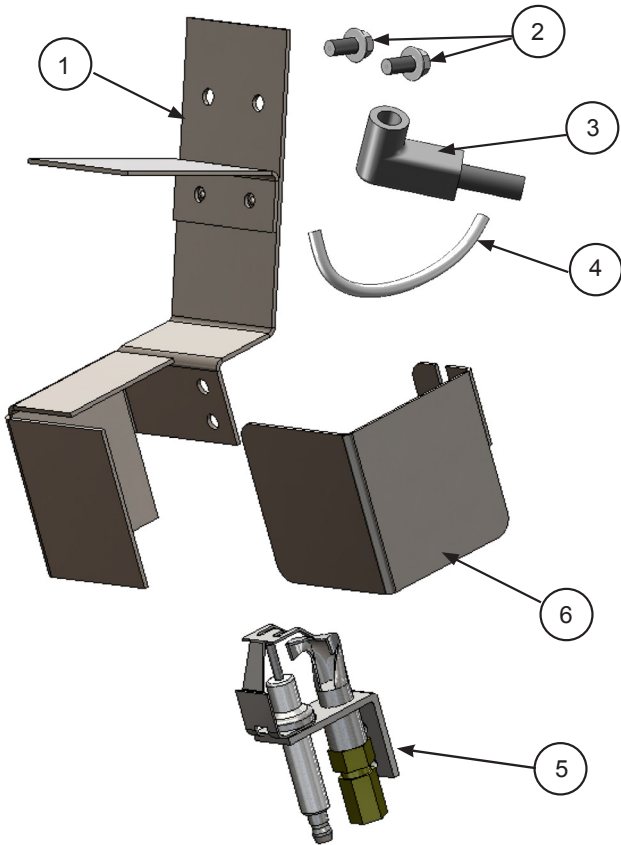

Spark Pilot Kit - Natural Gas 550001911 Spark Pilot Kit - LP/Propane 550001912

Item	Description	Qty.
1	PILOT BRACKET ASSEMBLY	1
2	BRACKET SCREW	2
3	SPARK CABLE	1
4	PILOT TUBING, 1/8" x 24"	1
5	NATURAL GAS Q345A PILOT	1
	LP Q345A PILOT	
6	PILOT TEMPERATURE SHIELD	1

* Included with #3 - Pilot Tube Assembly Kit (above)

ROLLOUT & SPILL SWITCH

Item #	Description	Part #	Qty.
1	50 - TEMP. SENSOR BRACKET	3261101	1
	100 - TEMP SENSOR BRACKET	3262001	1
	125 - TEMP SENSOR BRACKET	109008517	1
	150 - TEMP SENSOR BRACKET	109008517	1
	200 - TEMP SENSOR BRACKET	3262001	1
2	CONTROL-FIXED TEMPERATURE THERMO (ROLLOUT SWITCH)	AQ02101	1
3	SCREW - #6 X 1/4 HEX HD	HW06501	2

The rollout switch is located on the base.

NOTE: The quantities above are for each switch.

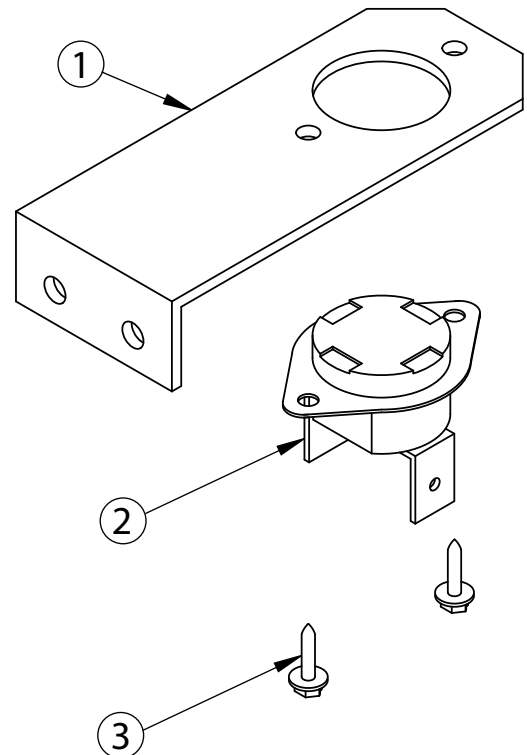

REPLACEMENT PARTS

BASE

UTICA BOILERS, INC.

DRAWN BY: VTB REV: 1 PART NO.: A1520
 DATE: 4/28/97 NOTE: DO NOT ALTER THIS MASTER

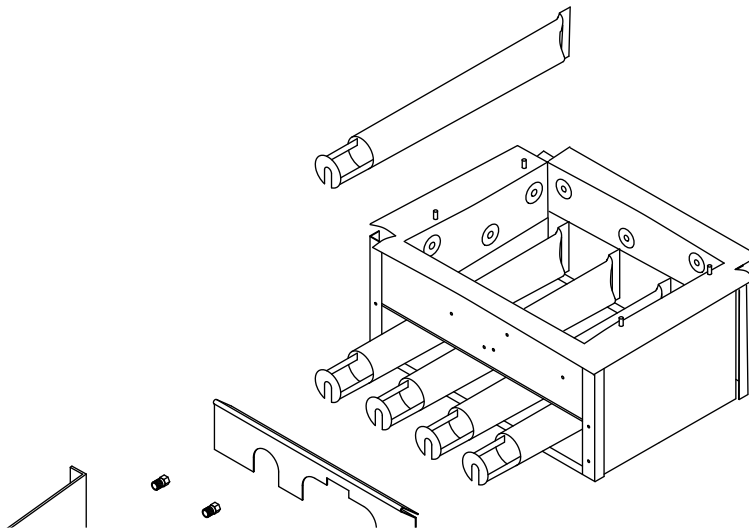

Item #	Description	Part #	Qty.
1	BURNER TUBE 1 1/2" - -50	240005543	1
	BURNER TUBE 1 1/2" - -100		2
	BURNER TUBE 1 1/2" - -125 & 150		3
	BURNER TUBE 1 1/2" - -200		4
2	BASE W/INSUL - -50	5611607	1
	BASE W/INSUL - -100	5611608	
	BASE W/INSUL - -125 & 150	5611609	
	BASE W/INSUL - -200	5611604	
3	BURNER DOOR - -50	32512501	1
	BURNER DOOR - -100	32523001	
	BURNER DOOR - -125	32523101	
	BURNER DOOR - -150	109008513	
	BURNER DOOR - -200	109008514	
4	MANIFOLD - -50	356-2-1.01	1
	MANIFOLD - -100	356-2-1.02	
	MANIFOLD - -125 & 150	356-2-1.03	
	MANIFOLD - -200	356-2-1.04	

Item #	Description	Part #	Qty.
5	SCREW 3/8" HEX	HW005.01	4
6	GAS VALVE VR8204H-1006 - 50 - 150 SPARK NAT	VG01101	1
	GAS VALVE VR8304H-4206 - - 200 SPARK NAT	VG01103	
	GAS VALVE VR83043216 - -50 - 200 LP	VG01104	
7	ORIFICE 3.2mm - 50, 100, 150, 200	240007406	*
	ORIFICE 2.9mm - 125	240007404	
	ORIFICE #47 LP - 50, 100, 150, 200	240007403	
NOT SHOWN	Combustible Base Flooring - 50	325-2-8.01	1
	Combustible Base Flooring - 100	325-2-8.02	
	Combustible Base Flooring - 125, 150	325-2-8.03	
	Combustible Base Flooring - 200	325-2-8.04	
*Orifice Qty's per model: Model 50- qty 1. Model 100- qty 2. Model 125 & 150- qty 3. Model 200- qty 4.			

REPLACEMENT PARTS

JACKET

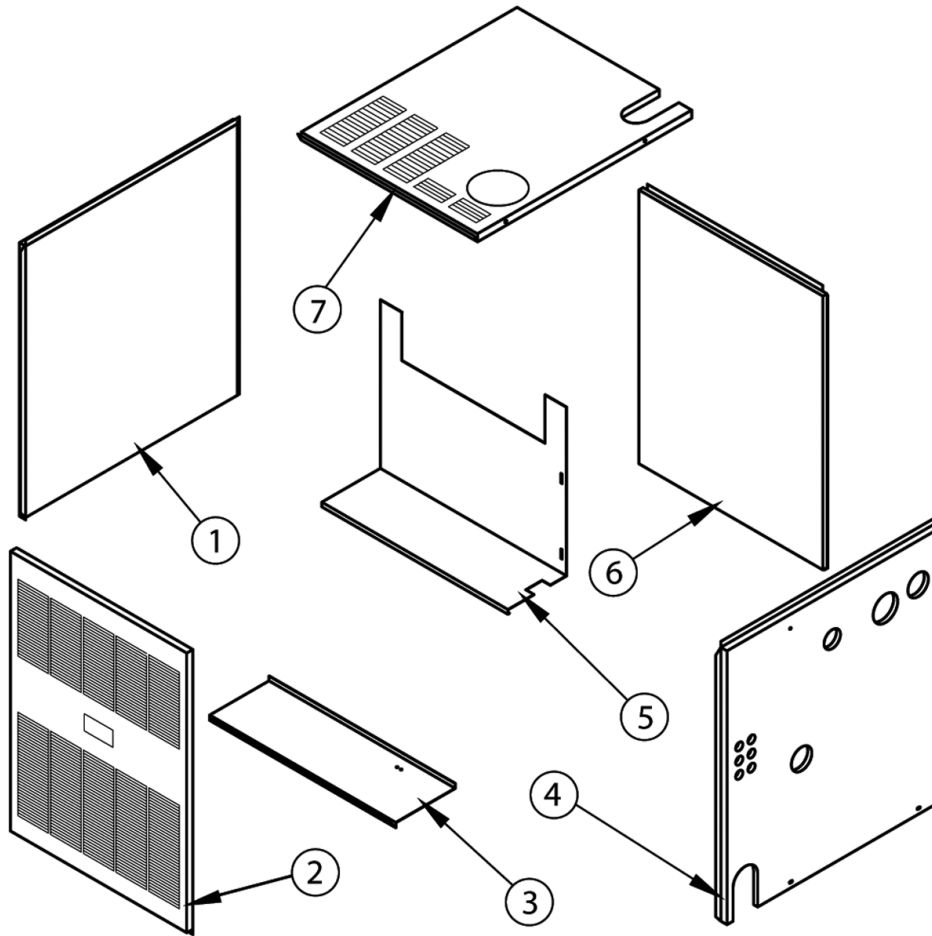

ITEM	DESCRIPTION	PART NUMBER	QTY.
1	PANEL - LEFT 50-200	3162702	1
2	PANEL - FRONT -50	315-2-19.01	1
	PANEL - FRONT -100	315-2-19.02	
	PANEL - FRONT -125 & 150	315-2-19.03	
	PANEL - FRONT -200	315-2-19.04	
3	PANEL - BASE -50	315-2-12.01	1
	PANEL - BASE -100	315-2-12.02	
	PANEL - BASE -125 & 150	315-2-12.03	
	PANEL - BASE -200	315-2-12.04	
4	PANEL - RIGHT -50-200	3162701	1
5	PANEL - SEPARATOR -50	31522401	1
	PANEL - SEPARATOR -100	31522402	
	PANEL - SEPARATOR -125 & 150	31522403	
	PANEL - SEPARATOR -200	31522404	

HEAT EXCHANGER

COMPLETE HEAT EXCHANGER ASSEMBLY	
HEAT EXCHANGER 2 SECTION - 50	912000001
HEAT EXCHANGER 3 SECTION - 100	912000002
HEAT EXCHANGER 4 SECTION - 125 &150	912000003
HEAT EXCHANGER 5 SECTION - 200	912000004

PIPING & CONTROLS

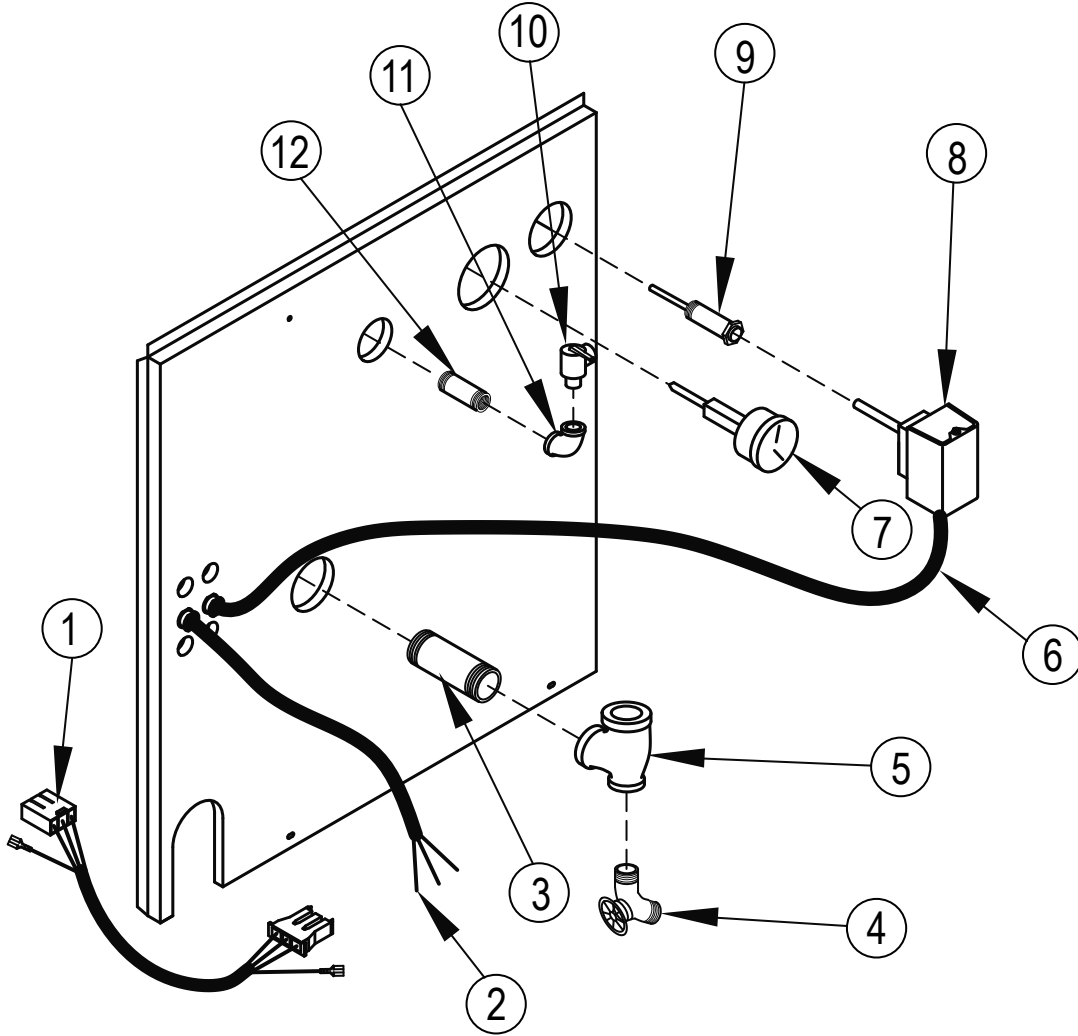

ITEM	DESCRIPTION	P/N	QTY.
1	HARNESS IGN/GV 36"	37413601	1
2	HARNESS - CIRCULATOR 72"	37519501	1
3	PIPE - NPL 1¼ X 4½ NPT 1	1310002	1
4	DRAIN - SHORT	HW-016.03	1
5	PIPE - TEE 1¼ X ¾ X 1¼	1510001	1
6	HARNESS- CONTROL/LIMIT 38"	37518901	1
7	GAUGE - THERALTIMETER	1260006	1
8	CONTROL L4080B	AQ02201	1
9	WELL ¾" X 3"	AQ-020.01	1
10	RELIEF VALVE 30# ¾"	VR-001.01	1
11	PIPE - ELBOW ¾" 90°	1190001	1
12	PIPE - NPL ¾" X 4"	1310001	1

REPLACEMENT PARTS

ELECTRICAL

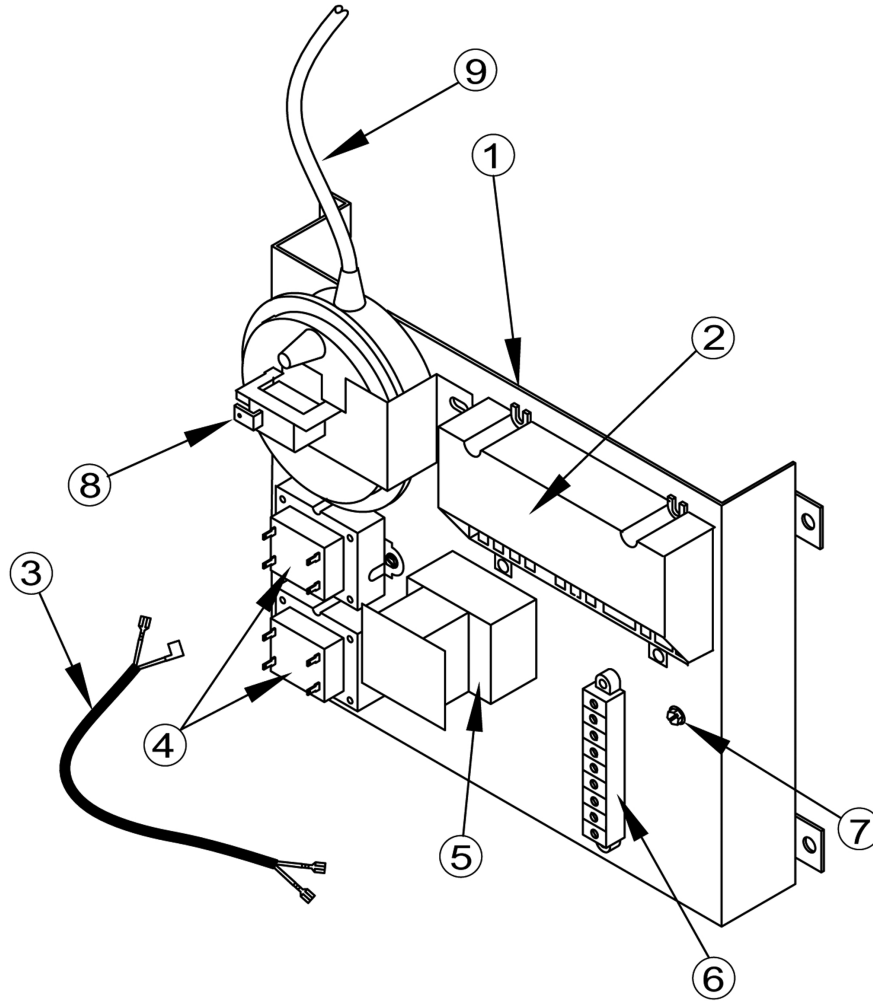

ITEM	DESCRIPTION	P/N	QTY.
1	CONTROL SUPPORT BRACKET	31522201	1
2	PLT SPARK CONTROL	14662070	1
3	WIRE ROLLOUT SWITCH 40"	37614501	1
4	TRANSFORMER - 40VA	550001339	2
5	CONTROL R8222C-1008 (RELAY)	1410001	1
6	9 TERM STRIP	EF04001	1
7	SCREW 10-32X5/16 GREEN GROUND	HW09001	1
8	PRESSURE SWITCH (FS6205A-2413) 50B - 150B	SS00801	1
	PRESSURE SWITCH (FS6273A-3065) 200B ONLY	SS00802	1
9	HW TUBE SIL ORANGE 1/8ID	HW09701	1
FULLY ASSEMBLED CONTROL BRACKET			
	CONTROL BRACKET SUB-ASSY 50B - 150B	31522901	
	CONTROL BRACKET SUB-ASSY 200B	31522902	
(P/N 31522901 & 31522902 INCLUDE PART # 1-8 & ALL WIRING)			

REPLACEMENT PARTS

FLUE COLLECTOR & VENTER COMPONENTS

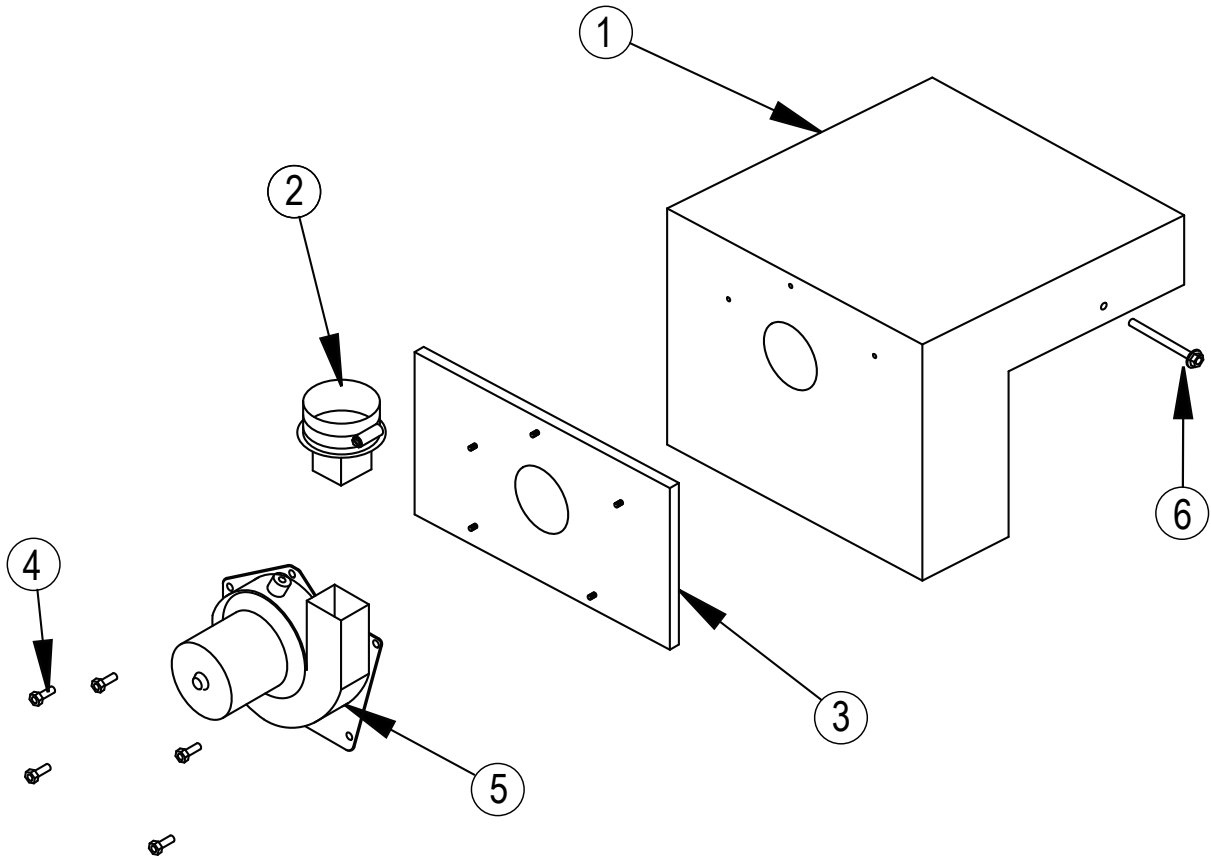

ITEM	DESCRIPTION	P/N	QTY.
1	FLUE COLLECTOR -50	34524802	1
	FLUE COLLECTOR -100	34524804	
	FLUE COLLECTOR -125	34524805	
	FLUE COLLECTOR -150	34524806	
	FLUE COLLECTOR -200	34524808	
2	VENT ADAPTER -50, -100, & -125	345-2-7.01	1
	VENT ADAPTER -150 & -200	345-2-7.02	
3	VENTER MOUNTING PLATE -50 ONLY	34524902	1
4	HW SCR ¼ -20x ½	HW-005.01	5
5	VENTER -50—200	DC00402	1
6	BOLT ⅝"-18 x 1½	14695039	2



Columbia Company
Main offices and factory
Pottstown, PA