

USER'S INFORMATION MANUAL SERIES CDVB GAS FIRED HOT WATER HEATING BOILER

WARNING: If the information in this manual is not followed exactly, a fire or explosion may result causing property damage, personal injury or loss of life.

- Do not store or use gasoline or other flammable vapors and liquids in the vicinity of this or any other appliance.

- WHAT TO DO IF YOU SMELL GAS
 - Do not try to light any appliance.
 - Do not touch any electrical switch; do not use any phone in your building.
 - Immediately call your gas supplier from a neighbor's phone. Follow the gas supplier's instructions.
 - If you cannot reach your gas supplier, call the fire department.

- Installation and service must be performed by a qualified installer, service agency or the gas supplier.

Do not use this boiler if any part has been under water. Immediately call a qualified service technician to inspect the boiler and to replace any part of the control system and any gas control which has been under water.

Should overheating occur or the gas supply fail to shut off, do not turn off or disconnect the electrical supply to the pump. Instead, shut off the gas supply at a location external to the appliance.



Columbia Boiler
Company
Main offices and Factory:
Pottstown, PA
P/N 37616201, Rev. C [8/2011]

**INSTRUCTIONS FOR OPERATION AND MAINTENANCE
OF GAS FIRED HOT WATER HEATING BOILER**

RETAIN FOR FUTURE REFERENCE

SAFETY SYMBOLS & WARNINGS

The following defined symbols are used throughout this manual to notify the reader of potential hazards of varying risk levels.

Columbia Boilers recommends all boiler maintenance be performed by a trained heating technician.

Before any procedures are attempted on this appliance, it is necessary to determine if the ignition system is a electric or standing pilot system. If you are uncertain, contact the manufacturer before proceeding.

DANGER



Indicates a hazardous situation which, if not avoided, WILL result in death or serious injury.

CAUTION



Indicates a hazardous situation which, if not avoided, may result in minor or moderate injury.

WARNING



Indicates a hazardous situation which, if not avoided, could result in death or serious injury.

NOTICE

Indicates information which should be followed to ensure proper installation and operation.

LIGHTING INSTRUCTIONS

WARNING



Before lighting any type of pilot burner (standing or intermittent), make certain the hot water boiler and system are full of water to minimum pressure of 12 lbs. per square inch in the system, and also make certain that the system is vented of air. Refer to the following appropriate lighting instruction.

LIGHTING PROCEDURE FOR BOILER WITH INTERMITTENT PILOT SYSTEM

WARNING



If you do not follow these instructions exactly, a fire or explosion may result causing property damage, personal injury or loss of life.

- A. This appliance is equipped with an ignition device which automatically lights the pilot. Do not try to light the appliance by hand.
- B. Before operating, smell all around the appliance area for gas. Be sure to smell next to the floor because some gas is heavier than air and will settle on the floor. Read *"What To Do If You Smell Gas"* on front page of this manual.
- C. Use only your hand to push in or turn the gas control knob. Never use tools. If the knob will not push in or turn by hand, don't try to repair it, call a qualified service technician. Force or attempted repair may result in a fire or explosion.
- D. Do not use this appliance if any part has been under water. Immediately call a qualified service technician to inspect the appliance and to replace any part of the control system and any gas control which has been under water.

Operating Instructions For Intermittent Pilot System

1. **STOP!** Read the safety information above.
2. Set the thermostat to lowest setting.
3. Turn off all electric power to the appliance.





4. This appliance is equipped with an ignition device which automatically lights the pilot. Do not try to light the pilot by hand.
5. Remove jacket front panel.
6. Turn gas control knob clockwise  to "OFF." See Figure 1.
7. Wait (5) minutes to clear out any gas. If you then smell gas, **STOP!** Follow *"What To Do If You Smell Gas"* on front cover of this manual. If you don't smell gas, go on to the next step.
8. Turn gas control knob counterclockwise  to "ON."
9. Replace jacket front panel.
10. Turn on all electric power to the appliance.
11. Set thermostat to desired setting.
12. If the appliance will not operate, follow the instructions *"To Turn Off Gas To Appliance"* on page 5 and call a qualified service technician or your gas supplier.

Figure 1 - Intermittent Pilot

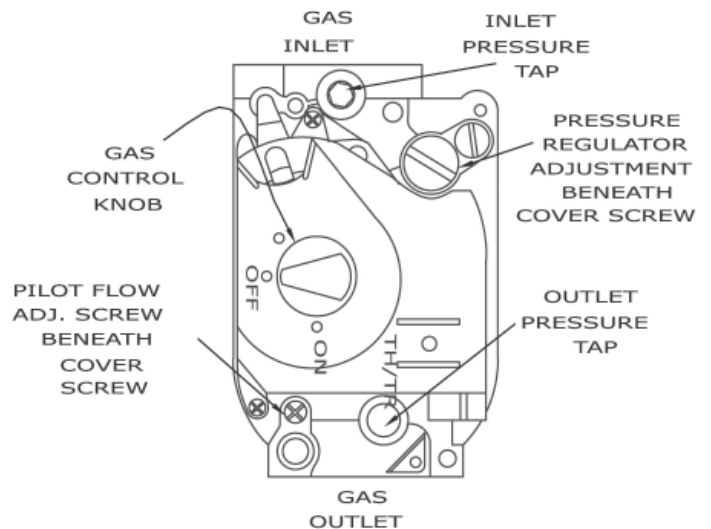

LIGHTING INSTRUCTIONS

To Turn Off Gas To Appliance

1. Set the thermostat to lowest setting.
2. Turn off all electric power to the appliance if service is to be performed.
3. Push in gas control knob slightly and turn clockwise  to "OFF." DO NOT FORCE.

Note Some gas control knobs cannot be turned from "PILOT" to "OFF" unless knob is pushed in slightly. **DO NOT FORCE.**

4. Replace access panel.

GENERAL INSTRUCTIONS

Before seasonal start-up, have a qualified service agency check the boiler for soot and scale in the flues, clean the burners and check the gas input rate to maintain high operating efficiency.

Put about one half teaspoon of SAE 20 or 30 non-detergent motor oil in each opening twice a year.



CAUTION

Do Not Over Oil!!



CAUTION

Label all wires prior to disconnection when servicing controls. Wiring errors can cause improper and dangerous operation.

Many circulators have an oil opening for the shaft bearing. This should be oiled at the same time for quiet operation. Follow the manufacturer's instructions for oiling the shaft bearing.

Verify proper operation after service.

The service agency or owner should make certain the system is filled with water to minimum pressure and open air vents, if used, to expel any air that may have accumulated in the system. Check the entire piping system and, if any leaks appear, have them repaired.

The venting system should be inspected at the start of each heating season. Check the vent pipe from the boiler to the chimney for signs of deterioration by rust or sagging joints. Repair if necessary. Remove the vent pipe at the base of the chimney or flue and using a mirror, check vent for obstruction and make certain the vent is in good working order.

Figure 2 - Circulator

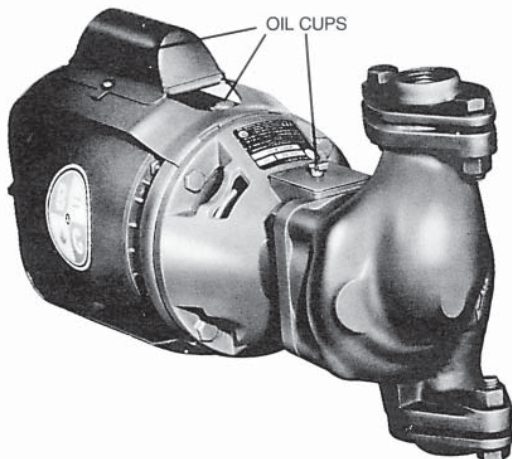

Many circulators like the one pictured in Figure 2 (above) require periodic servicing. The motor usually has openings at each end to lubricate the bearings.

Figure 3 - Boiler Flue Gas Passageways

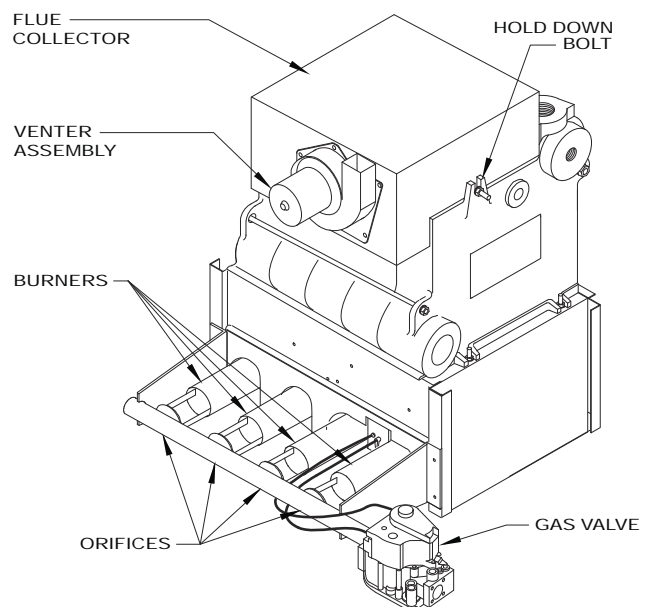

GENERAL INSTRUCTIONS

Before seasonal start up it is advisable to have a certified service agency check the boiler for soot and scale in the flues, clean the burners and check the gas input rate to maintain high operating efficiency. The service agency should make certain the system is filled with water to minimum pressure and open air vents - if used - to expel any air that may have accumulated in the system. The entire piping system should also be checked and if any leaks appear, they should be repaired immediately.

The venting system should also be inspected at the start of each heating season. The vent pipe from the boiler should be checked for signs of deterioration or sagging joints. Repair if necessary.



The following procedure should be followed to clean and check the flue gas passageways:

1. Remove the burners from the combustion chamber by raising the burners 1. up from the manifold orifices and pulling toward the front of the boiler, (See Figure 4)
2. Disconnect the vent pipe from the vent adapter.
3. Remove the jacket front panel. (See Figure 5)
4. Check venter assembly suction pressure.
 - Connect a slope manometer between the venter and the pressure switch with a tee and additional tubing and connectors.
 - Turn the boiler on and read suction pressure on the manometer. Reading should be negative (-) $.55 \pm .05$ inches of water column or higher for the DV50 thru 150 and negative (-) $.65 \pm .05$ inches of water column or higher for the DV200. If this reading is not attainable, contact a certified service agency.
5. Remove the flue collector and venter assembly from the boiler castings by loosening the hold-down bolts located on each side of the flue collector. (See Figure 3)
6. Visually inspect the venter assembly for any unusual wear or dirt build up.
7. If venter has oil cups lubricate venter motor once a month during the heating season with a few drops of non-detergent motor oil (SAE 20 or 30). Do not over oil.

8. Place a sheet of heavy paper or similar material in the bottom of the combustion chamber and brush down the flue passageways. The soot and scale will collect on the paper and is easily removed with the paper.

A visual check of the main burner and pilot flames should be made at the start of the heating season and again in mid-season.

The main burner flame should have a well defined inner blue mantel with a lighter blue outer mantel. (See Figure 6) If the flame does not appear this way, check the burner throats and burner orifices for lint or dust obstructions.

The pilot flame should envelop $3/8$ to $1/2$ inch of the tip of the ignition electrode. To adjust the pilot flame, remove the pilot adjustment cover screw on the gas valve and turn the inner screw clockwise  to decrease or counterclockwise  to increase the pilot flame. See Figure 1. Be sure to replace the cover screw after adjustment to prevent possible gas leakage.

The burners and pilot should be checked for signs of corrosion, rust or scale build-up, and cleaned with a nylon bristle brush.

The area around the boiler must be kept clear and free of combustible materials, gasoline and other flammable vapors and liquids.

The free flow of combustion and ventilating air to the boiler and boiler room must not be restricted or blocked.

In the event the flow of combustion products through the flueways or the boiler venting system becomes blocked, a flame roll-out safety switch will shut off the main burner gas. See Figure 5. If this condition occurs, do not attempt to place the boiler in operation. Contact a qualified service agency.

It is suggested that a certified service agency be employed to make an annual inspection of the boiler and heating system. They are experienced in making the inspection outlined above and in the event repairs or corrections are necessary, they can make the proper changes for safe operation of the boiler.

Figure 4 - Burners, Burner Orifices

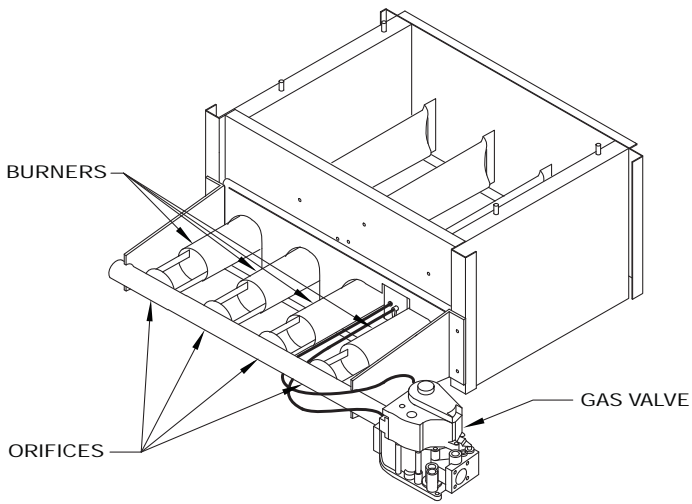
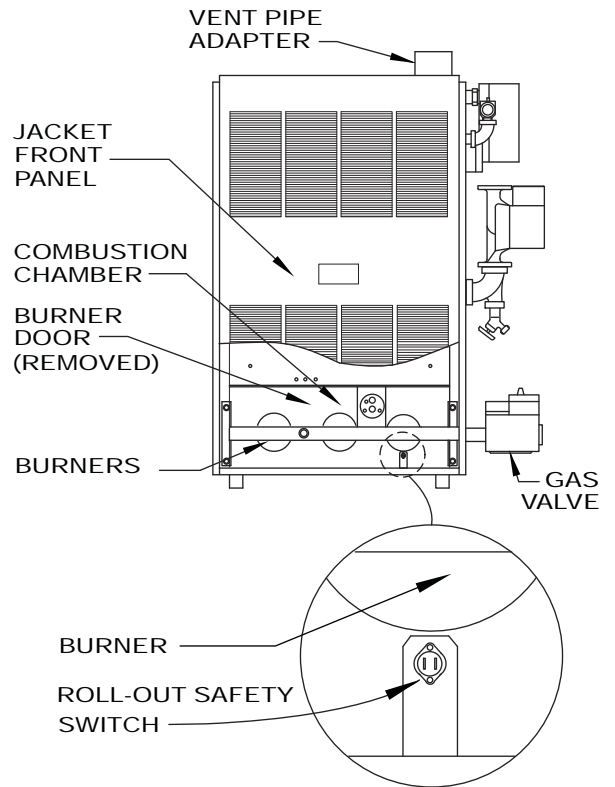

Figure 5 - Boiler Front with Safety Switch



(Location May Vary By Model)

Figure 6 - Burner Flame

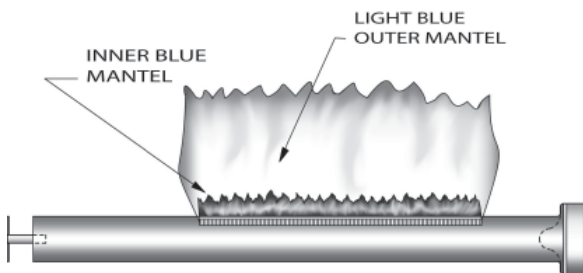
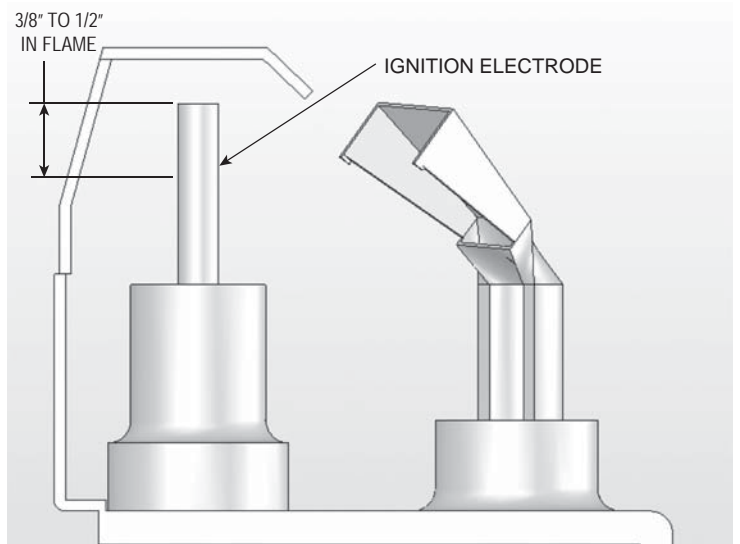

Figure 7 - Burners Pilot Flame



NOTES

NOTES



COLUMBIA BOILER COMPANY

Main offices and Factory: Pottstown, PA

Date of Installation: _____

Boiler Model #: _____

Installed By: _____