

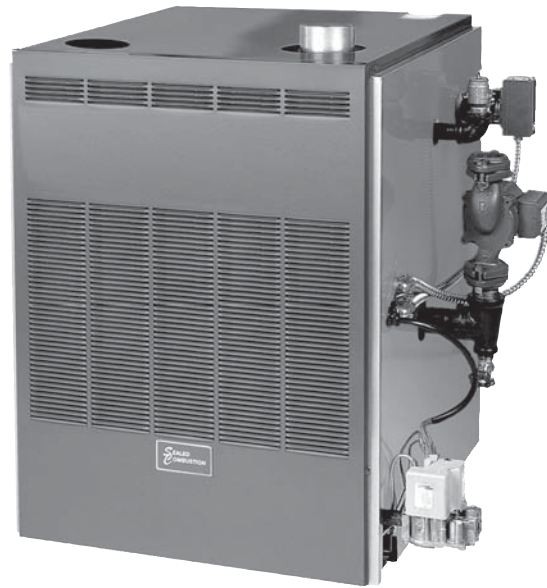

OSC SERIES

Direct Vent
Gas Fired Hot Water Boiler

INSTALLATION, OPERATION & MAINTENANCE MANUAL



C.S.A. Certified for
Natural gas or Propane

Tested for 100 psi. ASME
Working Pressure



An ISO 9001-2008 Certified Company

ECR International
2201 Dwyer Avenue, Utica NY 13501
web site: www.ecrinternational.com

P/N 37711001, Rev. B [08/2011]

TABLE OF CONTENTS

Introduction.....	3
Boiler Ratings, Capacities & Dimensions.....	4
Connecting Supply And Return Piping.....	5
General Information Gas Vents And Appliances.....	8
Vent Pipe Modification.....	9
Connect Gas Service.....	10
Electrical Wiring.....	12
Operating Instructions.....	13
Sequence Of Operation.....	14
General Instruction For Seasonal Start Up And Maintenance.....	15
Venting Instructions.....	19
Condensate Drains.....	24
Replacement Parts.....	32
Relief Valve Piping Supplemental Installation Instructions.....	40

SAFETY SYMBOLS

The following defined symbols are used throughout this manual to notify the reader of potential hazards of varying risk levels.



DANGER

Indicates a hazardous situation which, if not avoided, WILL result in death, serious injury.



WARNING

Indicates a hazardous situation which, if not avoided, may result in death, serious injury.



CAUTION

Indicates a hazardous situation which, if not avoided, may result in injury.

NOTICE

Indicates information which should be followed to ensure proper installation and operation.

IMPORTANT: Read the following instructions COMPLETELY before installing!

Keep This Manual Near Boiler And Retain For Future Reference.

WARNING

Keep boiler area clear and free from combustible materials, gasoline and other flammable vapors and liquids.



Do not obstruct air openings to the boiler room.

Modification, substitution or elimination of factory equipped, supplied or specified components may result in personal injury or the loss of life.

To the installer: Leave all instructions with the boiler for future reference.

When this product is installed in the Commonwealth of Massachusetts the installation must be performed by a Licensed Plumber or Licensed Gas Fitter.

To the owner: Installation and service of this boiler must be performed by a qualified installer.

INTRODUCTION

WARNING



Improper installation, adjustment, alteration, service or maintenance can cause injury or property damage.

- The installation must conform to the requirements of the authority having jurisdiction or, in absence of such requirements, to the National Fuel Gas Code, ANSI Z223.1/NFPA 54, and/or Natural Gas and Propane Installation Code, CAN/CSA B149.1.
- Where required by Authority having jurisdiction, installation must conform to Standard for Controls and Safety Devices for Automatically Fired Boilers, ANSI/ASME CSD-1.
- LOCATE BOILER on level, solid base as near the outside wall as possible and centrally located with respect to the heat distribution system as practicable.
- Allow 24 inches (61cm) at front and right side for servicing and cleaning.
- When installed in utility room, the door should be wide enough to allow the largest boiler part to enter, or to permit replacement of another appliance such as a water heater.
- The boiler shall be installed such that the gas ignition system components are protected from water, (dripping, spraying, rain, etc.), during appliance operation and service, (circulator replacement, condensate trap, control replacement, etc.).
- For installation on non-combustible floors only. The boiler must not be installed on carpeting (for installation on combustible flooring special base part no.325-2-8.00 Must be used). Minimum clearances to combustible constructions are:

TOP	18 in. (46 cm)
FLUE CONNECTOR	2 in. (5 cm)
FRONT	6 in. (15 cm)
REAR	4 in. (10 cm)
RIGHT SIDE	9 in. (23 cm)
LEFT SIDE	3 in. (8 cm)

Refer to Figure 1. Greater clearances for access should supersede fire protection clearances.

WARNING



All installations of boilers and venting should be done only by a qualified expert and in accordance with the appropriate boiler manual. Installing or venting a boiler or any other gas appliance with improper methods or materials may result in serious injury or death due to fire or to asphyxiation from poisonous gases such as carbon monoxide which is odorless and invisible.

Figure 1 - Min. Clearances To Combustible Materials

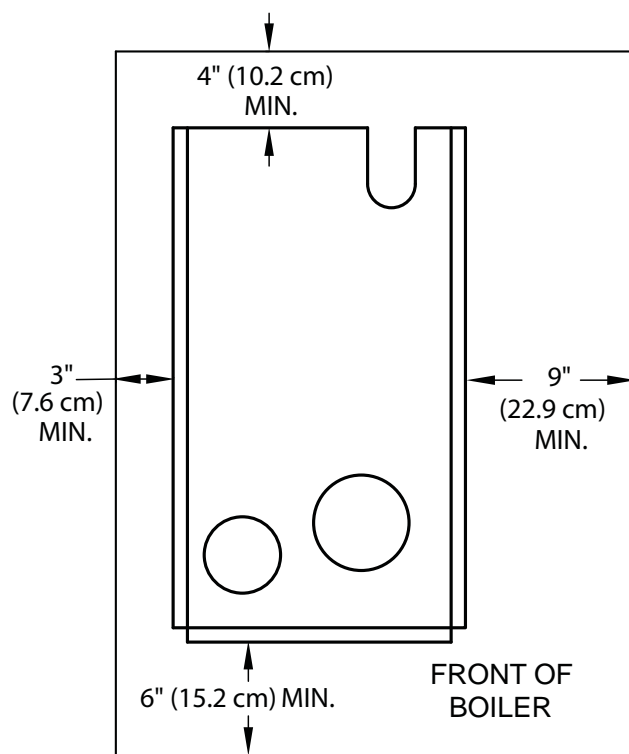

BOILER RATINGS, CAPACITIES & DIMENSIONS

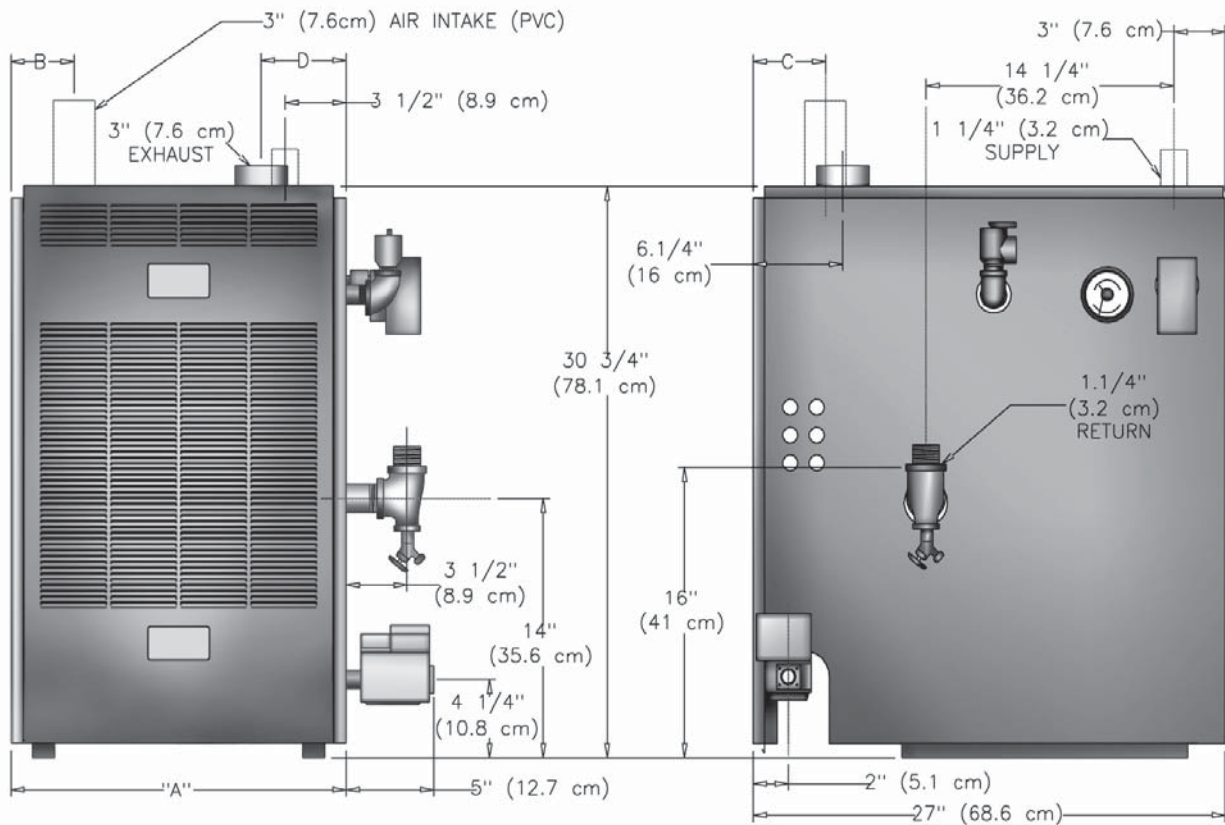

Boiler Ratings, Capacities & Dimensions

Boiler No.	Input Btu/Hr.	Heating Capacity Btu/Hr.	I=B=R Net Output Btu/Hr.	Natural Gas Inlet	Dimensions				Supply & Return Tappings	No. Of Burners	Water Content	AFUE Ratings
					A	B	C	D				
3 Section	50,000 (14.7 KW)	44,000 (12.9 KW)	38,000 (11.1 KW)	1/2" (1.27 cm)	15.1/8" (38 cm)	3.1/2" (9 cm)	3.1/2" (9 cm)	5" (12.7 cm)	1.1/4" (3.2 cm)	2	4.0 gals (15.14 liters)	87%
4 Section	100,000 (29.3 KW)	87,000 (25.5 KW)	76,000 (22.3 KW)	1/2" (1.27 cm)	19" (48 cm)	3.1/2" (9 cm)	3.1/2" (9 cm)	6.1/2" (16.5 cm)	1.1/4" (3.2 cm)	3	5.6 gals (21.20 liters)	87%
5 Section	140,000 (41.0 KW)	122,000 (35.7 KW)	107,000 (31.3 KW)	1/2" (1.27 cm)	22.7/8" (58 cm)	4.1/4" (11 cm)	4.1/8" (11 cm)	8.3/8" (21.3 cm)	1.1/4" (3.2 cm)	4	7.2 gals (27.25 liters)	87%

NOTE: Input rating for applications 0-2000 ft (0-610m) above sea level.

United States: Over 2000 ft (610m) above sea level. Reduce input rate 4% for every 1000 ft (304m) above sea level.

Canada: 2000-4500 ft (610-1350m) above sea level. Reduce input rate 10%.

Canada over 4500 ft (1350m) above sea level. Contact Provincial authority having jurisdiction.

STANDARD EQUIPMENT:

Boiler Jacket, Cast Iron Boiler Battery, Limit Control, Removable Transformers, Plug in Relay, Theraltimeter Gauge, Circulator (field mounted), Main Gas Burners, Hot Surface Pilot; A.S.M.E Relief Valve, Drain Valve, Induced Draft Fan, Safety Pressure Switch, and Combination Intake/Exhaust Termination Kit.

All boilers are design certified for installation on non-combustible floors. For installation on combustible floors, use combustible floor kit.

This boiler is a Direct Vent Designed Certified appliance which requires a special horizontal through the wall venting system.

Use ONLY the venting material products listed below:

- HEAT-FAB® SAF-T-VENT™
- FLEX-L® STAR-34™
- ProTech™ FasNSeal®
- Z-FLEX® Z-VENT™

Consult venting addendum for maximum vent lengths and proper configurations.

Electrical service to be 120 Volts, 15 Amps, 60 Hz.

CONNECTING SUPPLY AND RETURN PIPING

1. See Relief Valve Piping Supplemental Installation Instructions located on page 40 of this manual.
2. Connect supply and return piping as suggested in **Figure 1** below when the boiler is used in connection with refrigerated systems:
 - A. Boiler used in connection with refrigeration system. Install piping in parallel with boiler, with appropriate valves to prevent chilled medium from entering boiler. See figure 2.
 - B. System piping connected to heating coils located in air handling unit exposed to refrigerated air circulation. Install flow control valves or other automatic means to prevent gravity circulation of boiler water during cooling cycle.
3. Maintain a minimum clearance of 1 inch (2.54cm) to hot water pipes.
4. Hot water boilers installed above radiation level or as required by Authority having jurisdiction must be provided with a low water cut-off device at the time of boiler installation.
5. When a boiler is connected to a heating system that utilizes multiple zoned circulators, each circulator must be supplied with a flow control valve to prevent gravity

NOTICE

Reduced pressure back flow preventer must be used under provisions required by the Environmental Protection Agency, (EPA).

Figure 1 - Near Boiler Supply & Return Piping

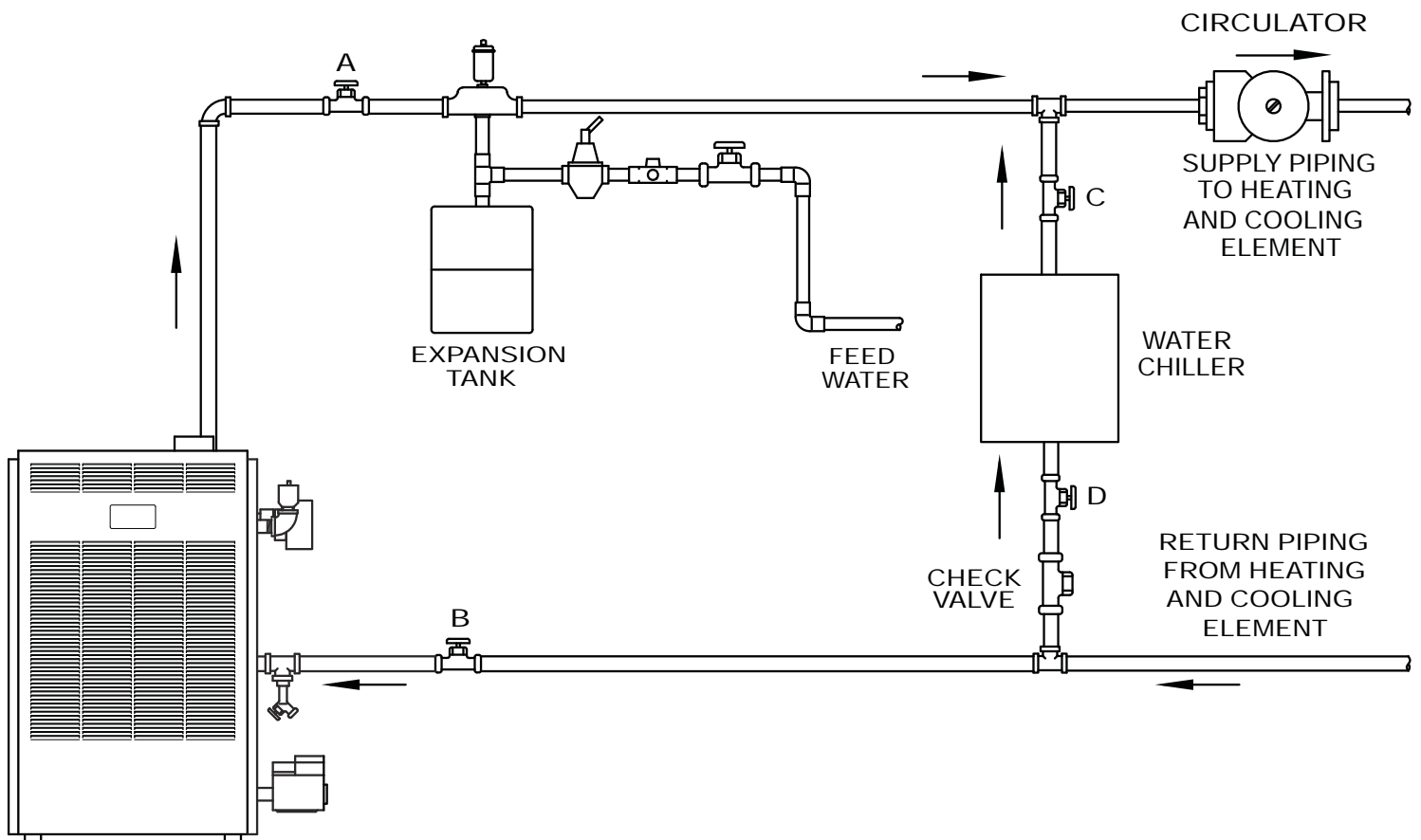

CONNECTING SUPPLY AND RETURN PIPING

Figure 3 - Bypass Piping

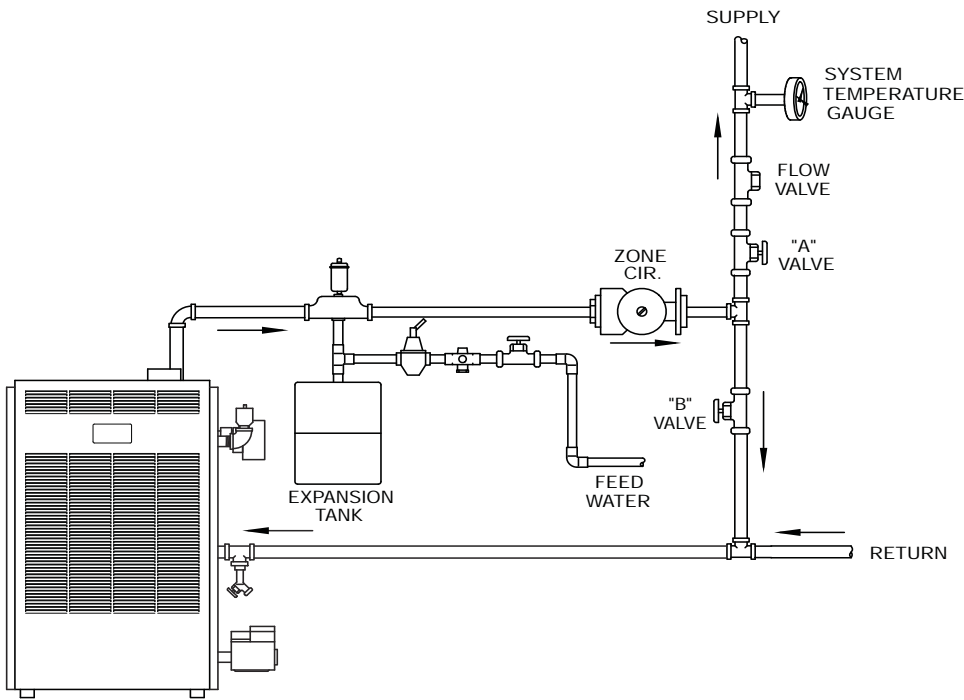

circulation.

6. Bypass piping is an option which gives the ability to adjust the supply boiler water temperature to fit the system or condition of the installation. This method of piping is not typically required for baseboard heating systems.

A. This method is used to protect boilers from condensate forming due to low temperature return water. Generally noticed in large converted gravity systems or other large water volume systems. See **Figure 3**.

B. These methods are used to protect systems using radiant panels and the material they are encased in from high temperature supply water from the boiler and protect the boiler from condensation. See **Figures 4 & 5**.

7. **NOTE:** When using bypass piping, adjust valves A and B, in **Figures 3 & 5**, until desired system temperature is obtained.

8. **NOTE:** When using a 4-way mixing valve, set control knob until desired temperatures are met. See instruction supplied with valve.

9. Bypass loop piping must be the same size piping as the supply and the return.

10. Typical installation using circulators is shown in **Figure 6** on following page.

11. Typical installation using zone valves is shown in **Figure 7** on following page.

12. For further piping information refer to the I=B=R installation and piping guide.

Figure 3 - Mixing Valve Piping

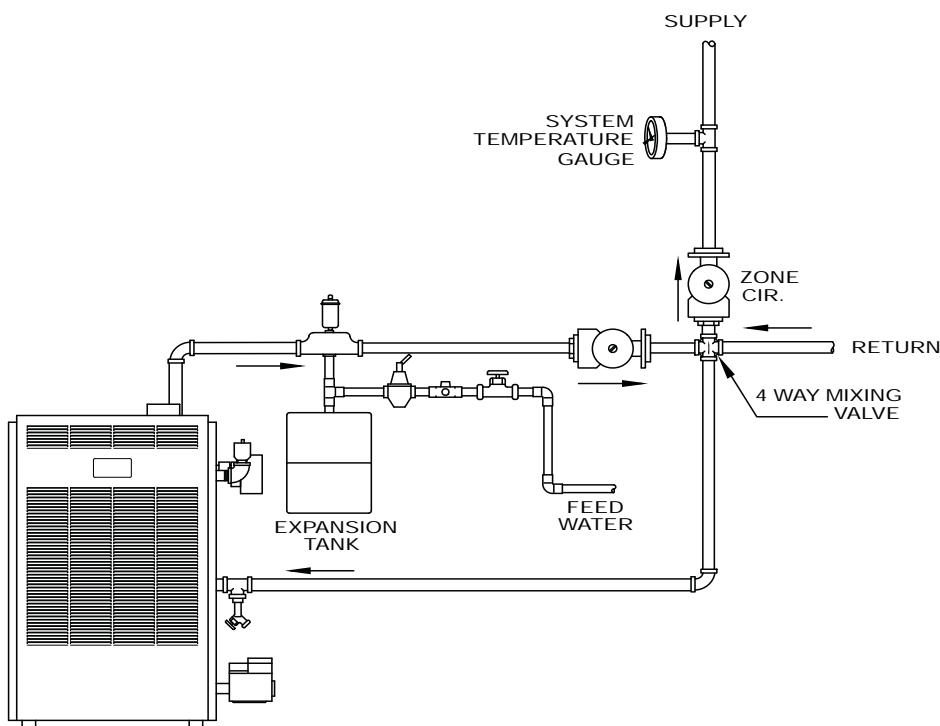

CONNECTING SUPPLY AND RETURN PIPING

Figure 5 - Primary Secondary Piping with Bypass

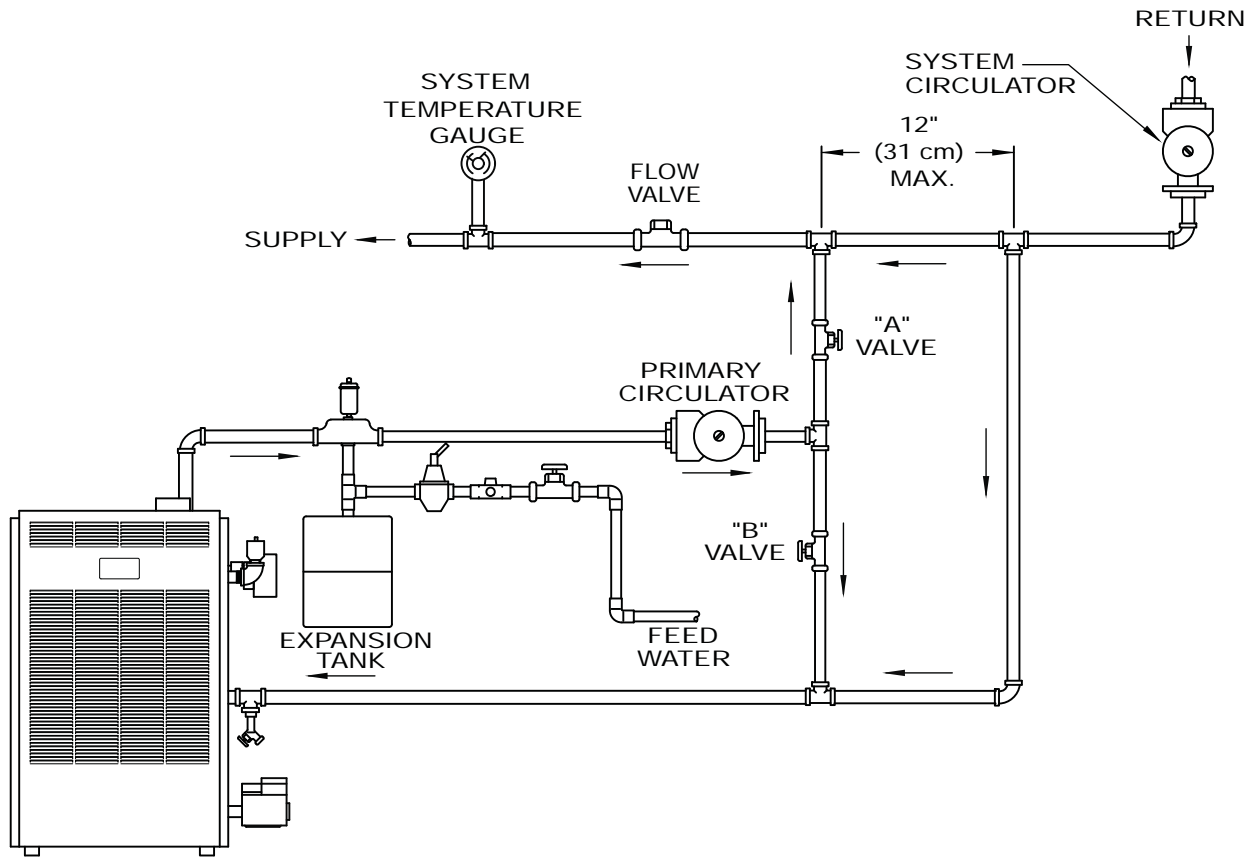
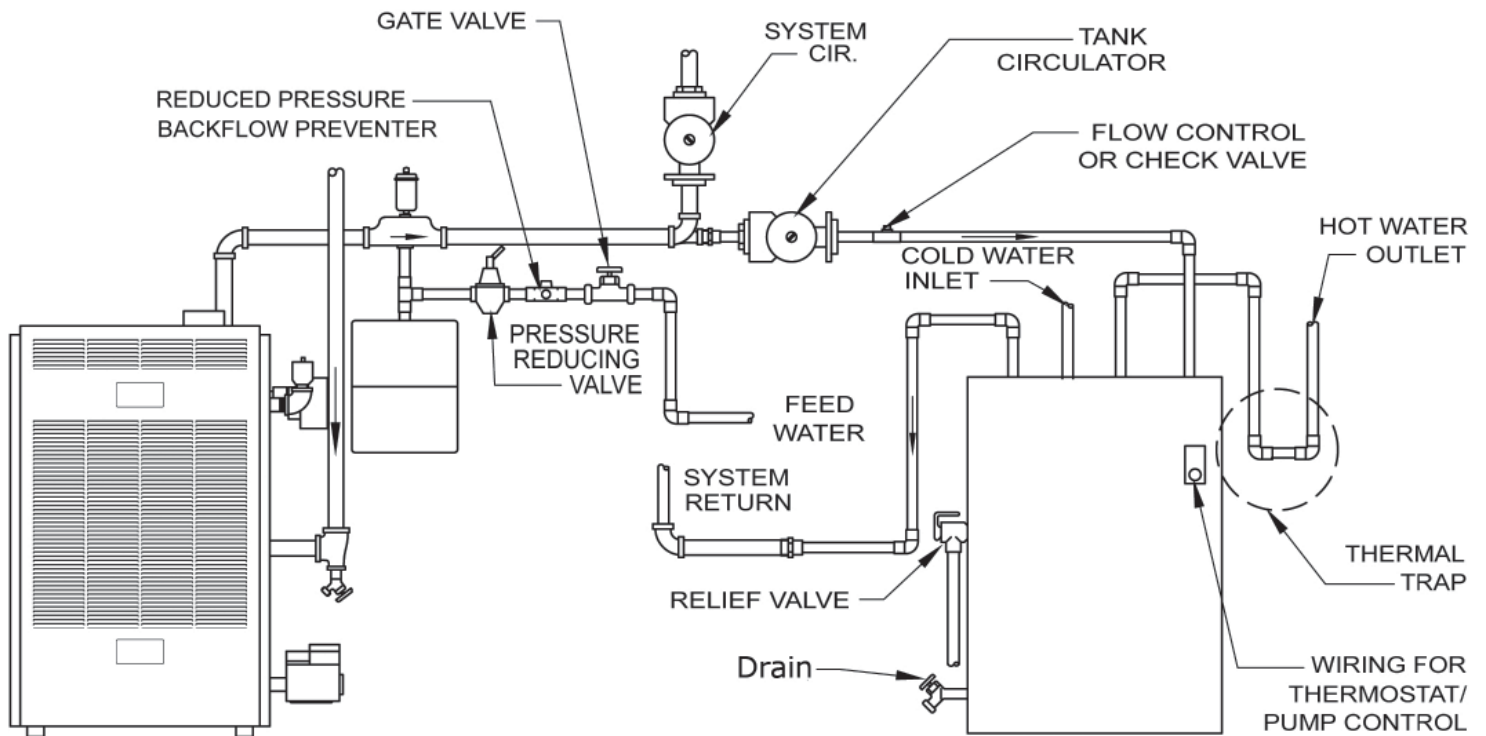
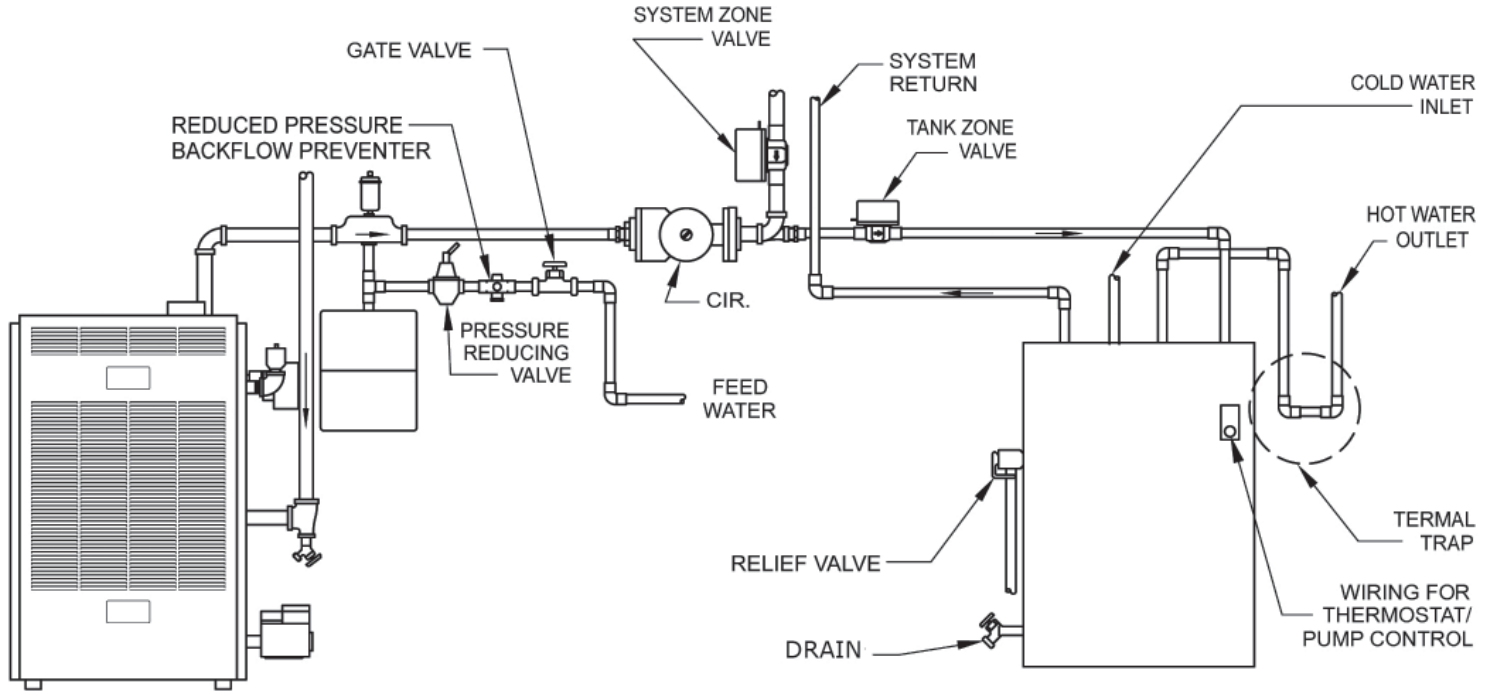

Figure 6 - Typical Installation Using Circulators



CONNECTING SUPPLY AND RETURN PIPING

Figure 7 - Typical Installation Using Zone Valves



GENERAL INFORMATION GAS VENTS AND APPLIANCES

By Federal Codes, gas appliances are categorized by the pressure and temperature of the flue gas vented from the appliance.

- Category I and II appliances are natural draft (draft hood) vented, with high flue gas temperatures (Category I), or low flue gas temperatures (Category II).
- Category III and IV appliances are fan forced vents with high temperature (Category III) or low temperature (Category IV) flue gasses. Appliance efficiency is directly related to flue gas temperature. Higher efficiency appliances remove more heat from the gas, so they will have lower temperature flue products.
- When flue gas temperatures are lowered, corrosive condensates may form in the gas vent or in the appliance. Condensates may form in Category II, III, IV appliance vents, so special corrosive resistant venting systems are required for higher efficiency appliances.
- Proper operation of the vent system and appliance is dependent upon the use of all parts specified by the manufacturer for use in the particular installation. Appliance and vent system performance may be affected by improper assembly.
- Vents for Category I appliances may not be suitable for use with Category II, III, or IV appliances because condensate may corrode the vent.
- Vents for Category III appliances may not be suitable for use with Category I appliances because flue gas temperatures may be too high.

VENT PIPE MODIFICATION

When an existing boiler is removed from a common venting system, the common venting system is likely to be too large for the proper venting of the appliances remaining connected to it.

REMOVAL OF BOILER FROM VENTING SYSTEM

At the time of removal of an existing boiler, the following steps shall be followed with each appliance remaining connected to the common venting system placed in operation, while the other appliances remaining connected to the common venting system are not in operation.

1. Seal any unused openings in the common venting system.
2. Visually inspect the venting system for proper size and horizontal pitch and determine there is no blockage or restriction, leakage, corrosion and other deficiencies which could cause an unsafe condition.
3. Insofar as is practical, close all building doors and windows and all doors between the space in which the appliances remaining connected to the common venting system are located and other spaces of the building. Turn on clothes dryers and any appliance not connected to the common venting system. Turn on any exhaust fans, such as range hoods and bathroom exhausts, so they will operate at maximum speed. Do not operate a summer exhaust fan. Close fireplace dampers.
4. Place in operation the appliance being inspected. Follow the lighting instructions. Adjust thermostat so appliance will operate continuously.
5. Test for spillage at the draft hood relief opening after 5 minutes of main burner operation. Use the flame of a match or candle, or smoke from a cigarette, cigar or pipe.
6. After it has been determined that each appliance remaining connected to a common venting system properly vents when tested as outlined above, return doors, windows, exhaust fans, fireplace dampers and any other gas burning appliance to their previous conditions of use.
7. Any improper operation of the common venting system should be corrected so the installation conforms with the National Fuel Gas Code, ANSI Z223.1/NFPA 54, and/or the Natural Gas and Propane Installation Code, CAN/CSA B149.1. When re-sizing any portion of the common venting system, the common venting system should be re-sized to approach the minimum size as determined using the appropriate tables in Chapter 13 of the National Fuel Gas Code, ANSI Z223.1/NFPA 54, and/or the Natural Gas and Propane Installation Code, CAN/CSA B149.1.

CONNECT GAS SERVICE

CAUTION

WHAT TO DO IF YOU SMELL GAS

Do not try to light any appliance.

Do not touch any electrical switches; do not use any phones in your building.

Immediately call your gas supplier from a neighbor's phone. Follow gas supplier's instructions.

If you cannot reach your gas supplier, call the fire department.

7. Tighten all joints securely.
8. Propane gas connections should only be made by a licensed propane installer.
9. Two-stage regulation should be used by the propane installer.
10. Propane gas piping should be checked out by the propane installer.



DANGER

Fire Hazard. Do not use matches, candles, open flames, or other methods providing ignition source. Failure to comply will result in death or serious injury.

The following rules apply:

1. Use piping materials and joining methods acceptable to authority having jurisdiction. In absence of such requirements:
 - USA** - National Fuel Gas Code, ANSI Z223.1/NFPA 54
 - Canada** - Natural Gas and Propane Installation Code, CAN/CSA B149.1
2. All pipe compound must be resistant to liquefied petroleum gas.
3. Install ground joint union in gas supply line between shut-off valve and boiler controls.
4. Install a sediment trap upstream of gas controls.
5. Use two pipe wrenches when making the connection to the gas valve to keep it from turning.
6. Install manual shut-off valve in vertical pipe about 5 feet (1.5m) above floor.

Checking The Gas Piping

Pressure test boiler and gas connection before placing boiler in operation.

- Pressure test over 1/2 psig (3.5 kPa). Disconnect boiler and its individual gas shutoff valve from gas supply system.
- Pressure test at 1/2 psig (3.5 kPa) or less. Isolate boiler from gas supply system by closing manual gas shutoff valve. See Figure 8.
- Locate leakage using gas detector, noncorrosive detection fluid, or other leak detection method acceptable to authority having jurisdiction. Do not use matches, candles, open flames, or other methods providing ignition source.
- Correct leaks immediately and retest.

Figure 8 - Manual Gas Shutoff Valve

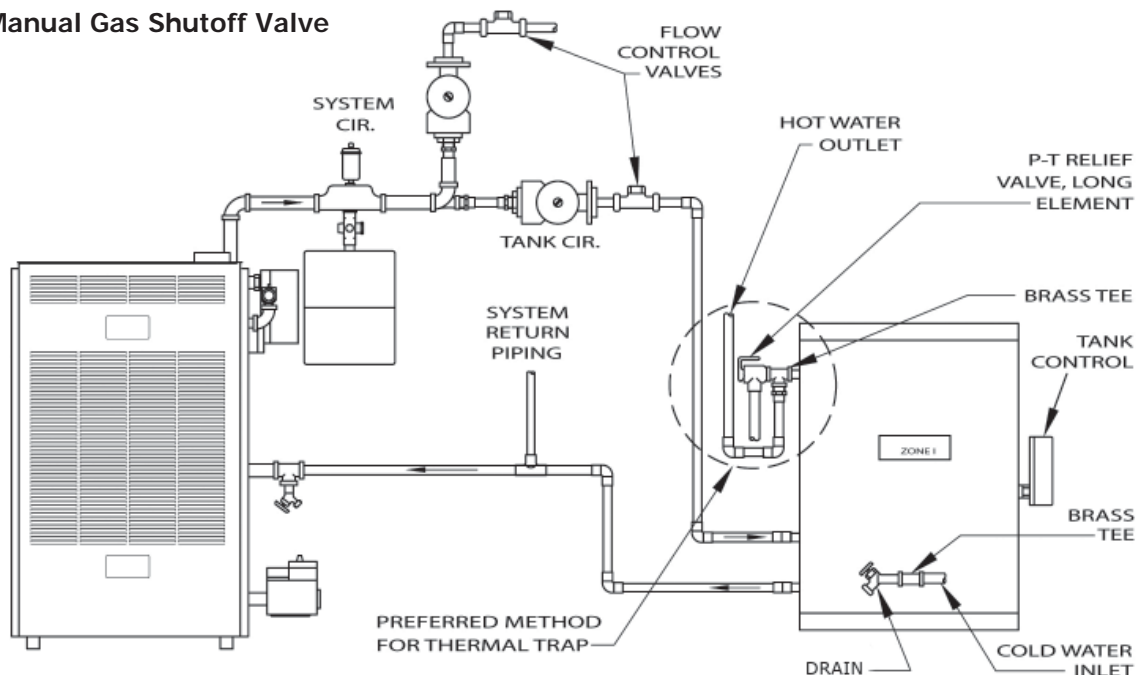

ELECTRICAL WIRING

The boiler, when installed, must be electrically bonded to ground in accordance with the requirements of the authority having jurisdiction or, in the absence of such requirements, with the National Electrical code, ANSI/NFPA 70, and/or the Canadian Electrical Code Part I, CSA C22.1, Electrical Code.

WARNING



Electrical shock hazard. Turn OFF electrical power supply at service panel before making electrical connections. Failure to do so could result in death or serious injury.

Component And Wire Coding Keys

- The keys that follow pertain to the HOT WATER CONTROL AND HOT SURFACE PILOT WIRING FOR SEALED COMBUSTION SERIES (diagrams on following page).
- If any of the original wiring supplied with the boiler is replaced it must be replaced with like wire size and type of insulation or equivalent.

CAUTION



Label all wires prior to disconnection when servicing controls. Wiring errors can cause improper and dangerous operation. Verify proper operation after servicing.

Install Your Thermostat

- The thermostat location has an important effect on the operation of your boiler system.
- BE SURE TO FOLLOW THE INSTRUCTIONS INCLUDED WITH YOUR THERMOSTAT.
- Locate the thermostat about four feet (4') above the floor on an inside wall.
- Check thermostat operation by raising and lowering thermostat setting as required to start and stop burners.

COMPONENT KEY	CODING
Thermostat (24 Volt)	TH-2
Transformer (120V/24V 40VA)	TR-1
Transformer (120V/24V 40VA)	TR-2
24 Volt Gas Valve	SV9501H
Pressure Switch	PS
Control Terminal	○
Relay Coil	1K
Relay Contacts	1K1
Relay Contacts	1K2
Limit Switch	LS
Circulator	CIR
Wire Connection	●
Not all components listed are used in all control systems.	

WIRING CODE KEY

—————	LINE VOLTAGE BY FACTORY
_____	LOW VOLTAGE BY FACTORY
- - - - -	LINE VOLTAGE BY INSTALLER
- - - - -	LOW VOLTAGE BY INSTALLER

THINGS TO AVOID WHEN LOCATING THERMOSTATS

DEAD SPOTS:

Corners and alcoves	Behind doors
---------------------	--------------

COLD SPOTS:

Concealed pipes or ducts	Concealed pipes
	Fireplace or chimney

Stairwells - drafts	TV sets
	Radios

Unheated rooms on other side of wall	Lamps
	Direct sunlight

Outside wall	Kitchens
--------------	----------

HOT SPOTS:

ELECTRICAL WIRING

HOT WATER CONTROL AND HOT SURFACE PILOT WIRING

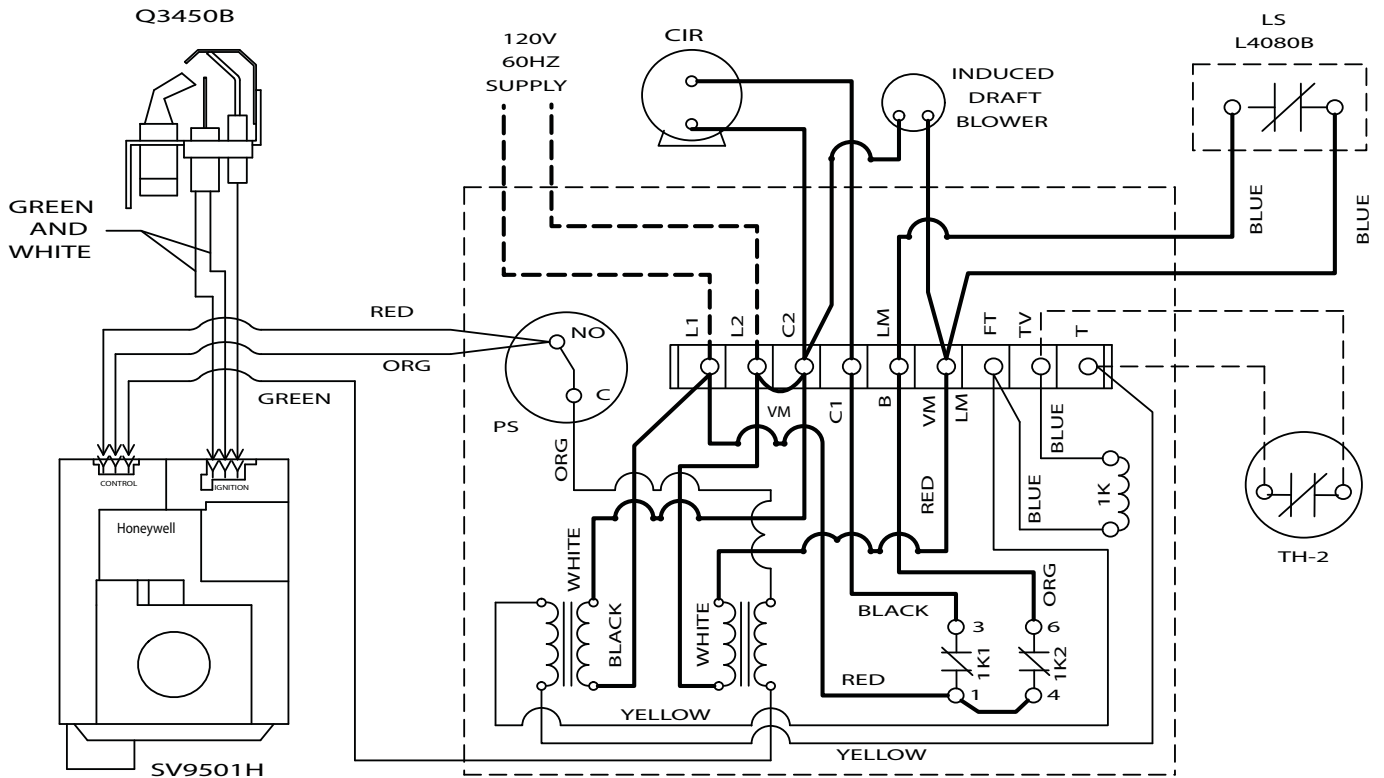
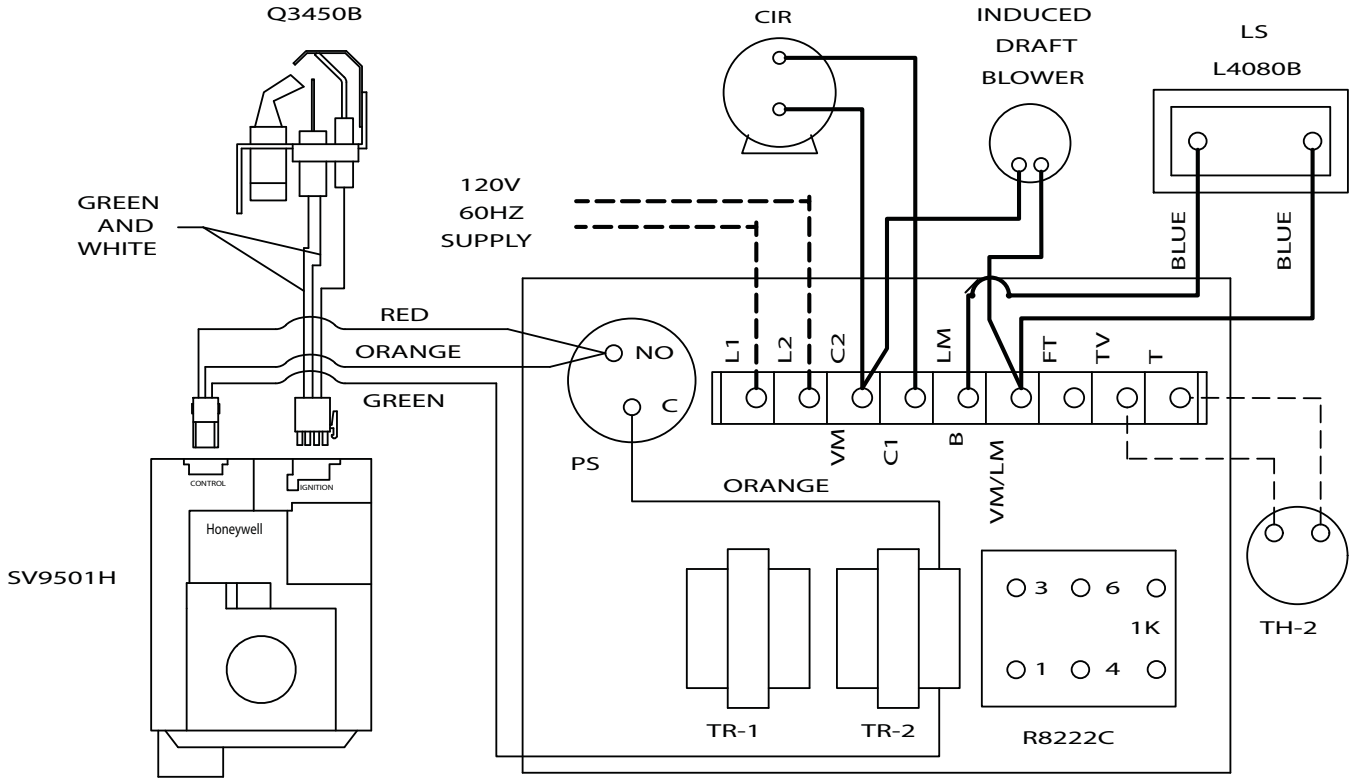

OPERATING INSTRUCTIONS

FOR BOILER WITH A HOT SURFACE PILOT SYSTEM

FOR YOUR SAFETY, READ BEFORE OPERATING!

WARNING



If you do not follow these instructions exactly, a fire or explosion may result causing property damage, personal injury or loss of life.

Before operating, make certain the boiler and system are full of water to minimum pressure (this is usually 12 psig on most systems) and system is vented of air. See the operating and lighting instructions.

WARNING

- A. This appliance is equipped with an ignition device which automatically lights the burner. Do not attempt to light the burner by hand.
- B. BEFORE OPERATING smell all around the appliance area for gas. Be sure to smell next to the floor because some gas is heavier than air and will settle on the floor.

WHAT TO DO IF YOU SMELL GAS

- Do not try to light any appliance.
- Do not touch any electrical switch; do not use any phone in your building.
- Immediately call your gas supplier from a neighbor's phone. Follow gas supplier's instructions.
- If you cannot reach your gas supplier, call the fire department.



- C. Use only your hand to push down or turn the knob. Never use tools. If the knob will not operate by hand, don't try to repair it, call a qualified service technician. Force or attempted repair may result in fire or explosion.
- D. Do not use this appliance if any part has been underwater. Immediately call a qualified service technician to inspect the appliance and to replace any part of control system and any gas control which has been under water.

OPERATING INSTRUCTIONS

OPERATING INSTRUCTIONS

1. STOP! Read the safety information on previous page.
2. Set thermostat to lowest setting.
3. Turn off all electric power to the appliance.
4. This appliance is equipped with an ignition device which automatically lights the pilot. DO NOT try to light the pilot by hand.
5. Move the ignition system control switch to the "OFF" position. See **Figure 10**.
6. Wait five (5) minutes to clear out any gas. If you then smell gas, STOP. Follow "What To Do If You Smell Gas" on previous page. If you don't smell gas, go to next step.
7. Move the ignition system control switch to the "ON" position. See **Figure 10**.
8. Turn on all electric power to the appliance.
9. Set thermostat to desired setting.
10. If the appliance will not operate, follow the instructions "To Turn Off Gas To Appliance" to right and call a qualified service technician or your gas supplier.

Figure 10 - Gas Control Screw

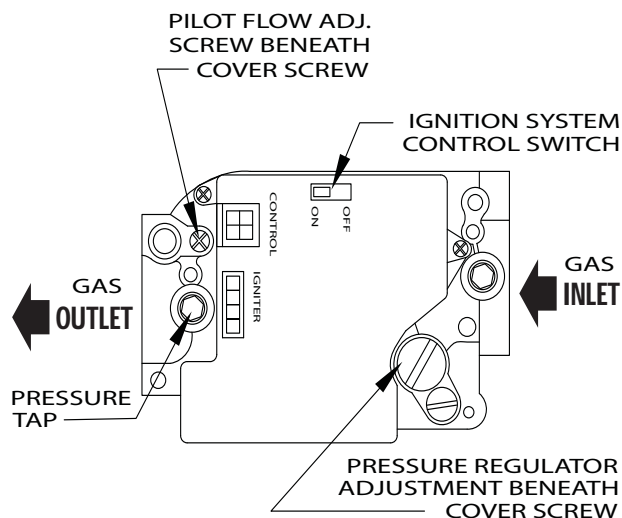

TO TURN OFF GAS TO APPLIANCE

1. Set thermostat to lowest setting.
2. Turn off all electric power to the appliance if service is to be performed.
3. Move the ignition system control switch to the "OFF" position. DO NOT FORCE

SEQUENCE OF OPERATION

On a call for heat:

1. The thermostat will actuate, completing the circuit between terminals T and T.
2. The R8222C relay coil will energize thus pulling in the relay contacts.
3. The circulator starts and power is switched to the limit. If limit circuit is closed the venter motor and TR-2 transformer are energized.
4. The venter motor starts and develops static pressure.
5. When the static pressure is reached the pressure switch pulls in completing the circuit between TR-2 and the SV9501H gas valve system.
6. The SV9501H opens the pilot valve and ignites pilot. After pilot is proven the main burner will ignite.
7. In the event the boiler water temperature exceeds the high limit setting the power will be interrupted to the venter motor, and TR-2, thus interrupting power to the ignition system. Power will remain off until the water temperature drops below the high limit setting. The circulator will continue to operate under this condition until the thermostat is satisfied.
8. Should the air flow (static pressure) be interrupted (ie. blocked flue), the pressure switch will sense a drop in pressure, opening the circuit between the ignition system and TR-2. The venter motor will continue to operate until static pressure is reached or thermostat is satisfied.
9. In the event the flow of combustion products through the boiler flue-ways becomes reduced or blocked, the Q34505 pilot will lose flame rectification and shut off the main burners. The boiler will try for ignition but will not light. If this condition occurs, turn off the main power and do not put the unit into operation.
10. When the thermostat is satisfied power is interrupted to the relay coil and the relay drops out cutting power to the circulator, venter motor, and TR-2.

GENERAL INSTRUCTION FOR SEASONAL START UP AND MAINTENANCE

It is suggested that a qualified service agency be employed to make an annual inspection of the boiler and the heating system. .

In the event repairs or corrections are necessary they can make the proper changes for safe operation of the boiler.

CAUTION



Label all wires prior to disconnection when servicing controls. Wiring errors can cause improper and dangerous operation. Verify proper operation after service.

BEGINNING OF EACH HEATING SEASON

1. Before seasonal start up it is advisable to have a competent service agency check the boiler for soot and scale in the flues, clean the burners and check the gas input rate to maintain high operating efficiency and safe operation.
2. The service agency should make certain the system is filled with water to minimum pressure and open air vents - if used - to expel any air that may have accumulated in the system.
3. Check automatic air vents for leakage.
4. Inspect the venting system at the start of each heating season. Check the pipe from the boiler for signs of deterioration and sagging joints. Repair if necessary. Remove the vent pipe from the boiler and check for obstructions.
5. Clean condensate tee & trap.
6. Periodically check the condensate trap for water/condensate. The trap should always have water in it. Refill the trap if it runs dry. If the trap runs dry then flue gasses can escape.
7. Inspect field sourced low water cutoff(s) annually or as recommended by low water cutoff manufacturer. Flush float type low water cutoff per manufacturer's instructions.

Periodic cleaning of the condensate collection system is required. When a condensate collection system is installed in a venting system, it is recommended that the cleaning become a part of the annual servicing. The procedure for cleaning this system is as follows:

1. Remove tubing from condensate tee.
2. Empty all liquid from tubing.
3. Rinse tubing inside & out in a sink with water.
4. If the inside of the tubing cannot be cleaned, the tubing should be replaced with the same type and size of tubing.
5. Add water to trap before replacing.
6. Replace tubing as described in **Figure 11**.
7. Visually inspect entire piping system and if any leaks appear, have them repaired as soon as possible. DO NOT use petroleum based stop leak compounds.

Figure 11 - Condensate Collection System

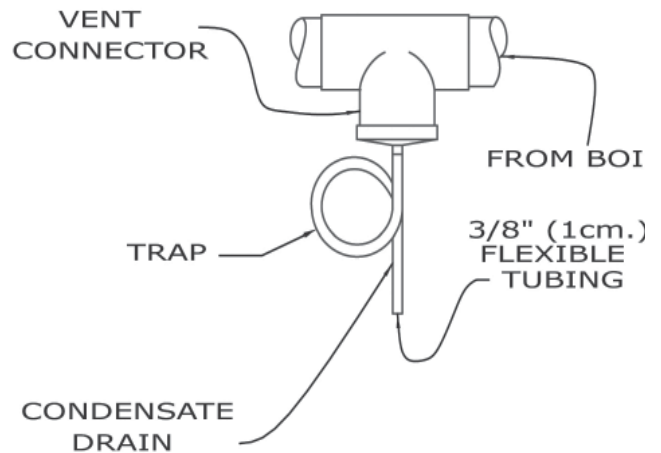

GENERAL INSTRUCTION FOR SEASONAL START UP AND MAINTENANCE

The following procedure should be followed to clean and check the flue gas passageways:

1. Turn off gas to the boiler at the manual gas
2. Remove the jacket front panel. See **Figure 12**.
3. Disconnect the vent pipe from the vent pipe adapter.
4. Disconnect the air inlet pipe from the coupling. See **Figure 13** for coupling location.
5. Remove the air box covers. See **Figure 13**.
6. Remove the burners from the combustion chamber by raising the burners up from the manifold orifices and pulling toward the front of the boiler. See **Figure 14**.
7. Remove top panel. See **Figure 12**.
8. Remove the flue collector and venter assembly from the boiler castings by removing the hold-down screws located on each side of the flue collector. See **Figure 15**.
9. Remove the baffles from the heat exchanger. See **Figure 13**.
10. Visually inspect baffles for any unusual wear or soot build up. Clean if necessary.
11. Visually inspect venter assembly for any unusual wear or dirt build up. Vacuum if necessary.
12. Place a sheet of heavy paper or similar material in bottom of the combustion chamber and brush down the flue passageways. The soot and scale will collect on the paper and is easily removed with the paper.
13. Replace the Flue Collector using the hold down screws and silicone in place with GE IS 808 silicone or similar. See **Figure 15**.
14. Repeat steps 1-5 in reverse order to reassemble the boiler.

Figure 12 - Front Panel

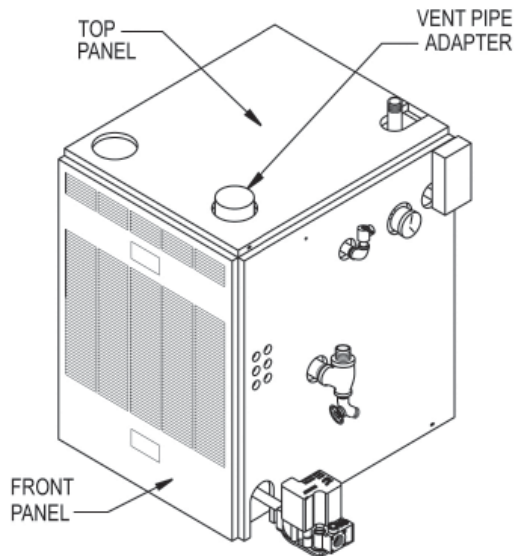

Figure 13 - Air Box Cover

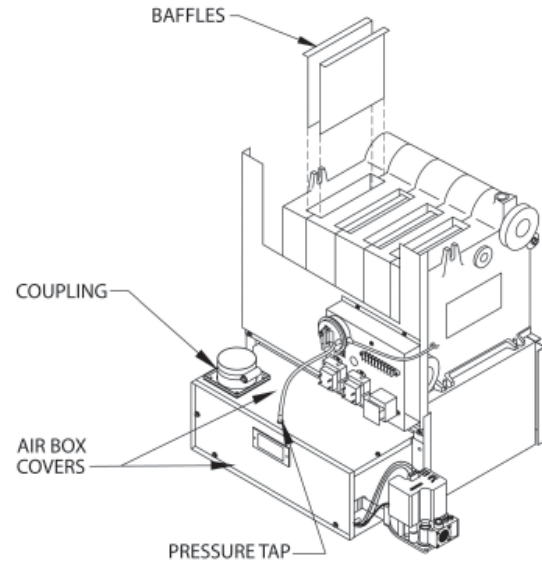

Figure 14 - Main Gas Burner Tubes

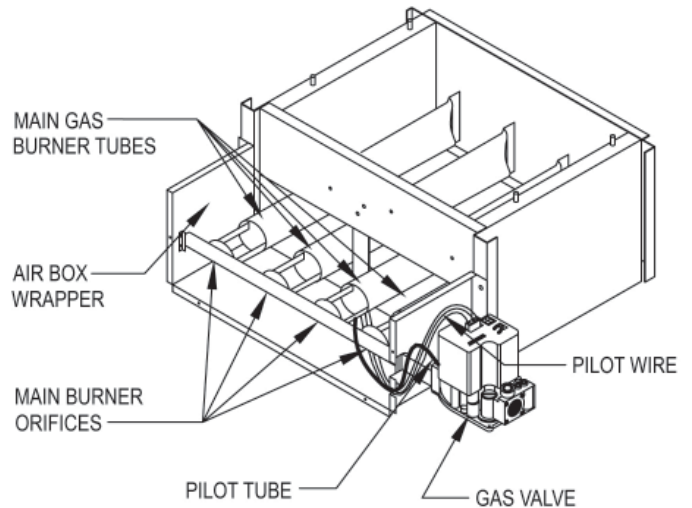
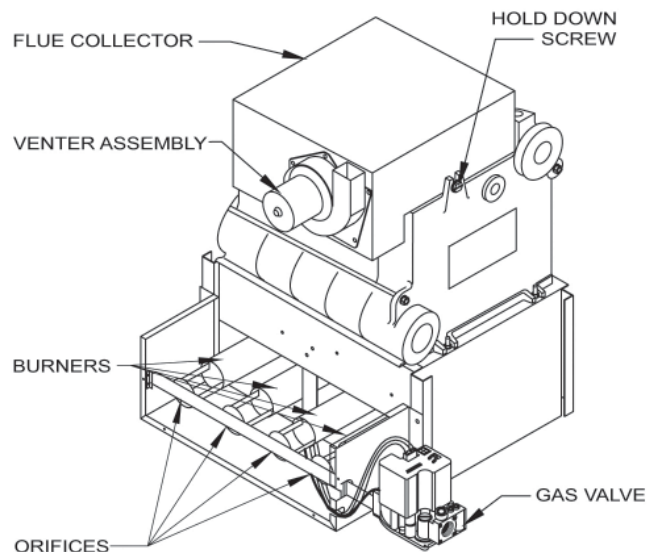
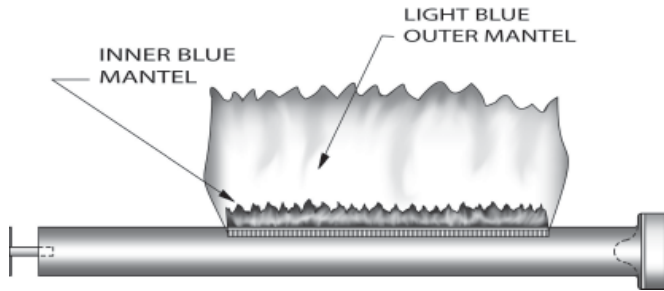

Figure 15 - Flue Collector and Venter Assembly



GENERAL INSTRUCTION FOR SEASONAL START UP AND MAINTENANCE

Figure 16 - Gas Burner Flame



The main burner flame should form a sharp blue inner mantel with no yellow.

Figure 17 - Gas Burner Pilot

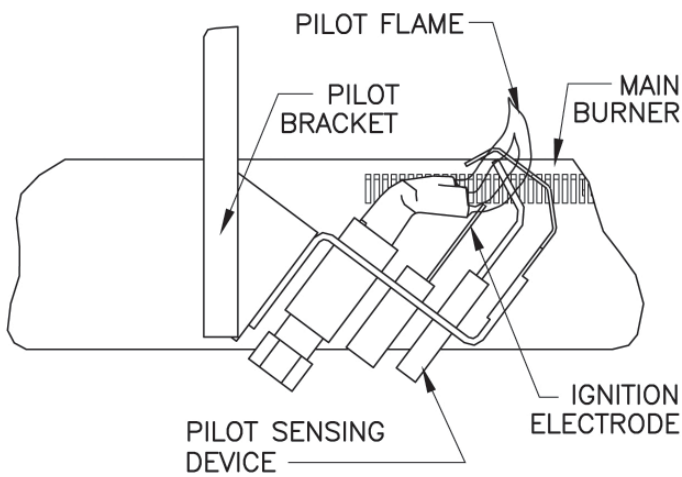

15. Start boiler to insure proper operating condition.
16. Keep area around boiler clean and free of combustible materials such as gasoline, paints, paint thinner and other such flammable vapors and liquids.
17. The free flow of combustion and ventilating air to boiler and boiler room must not be restricted or blocked.
18. Some circulators require periodic servicing. These circulators usually have oil cups or openings at each end of the motor and one for the shaft bearing. Put about one teaspoon of SAE 20 or 30 non-detergent motor oil in each opening twice per year. DO NOT OVER OIL. Follow manufacturer's instructions attached to circulator. When oil cups or holes are not provided, bearings are either permanently lubricated or water lubricated.

Visually check the main burners and pilot flame at the start of each heating season and again midway through the season.

- A. Check the burner throats and burner orifices for lint and dust obstructions. See **Figure 15**.
- B. The main burner flame should have a well defined inner blue mantel with a lighter blue outer mantel. See **Figure 16**.
- C. The pilot flame should envelop 3/8" (0.95 cm) to 1/2" (1.27 cm) of the tip of the pilot sensing device. See **Figure 17**.

GENERAL INSTRUCTION FOR SEASONAL START UP AND MAINTENANCE

Adjusting the pilot flame:

1. Remove pilot adjustment cover screw.
2. Turn inner screw (adjustment screw) clockwise ↻ to decrease and counterclockwise ↻ to increase pilot flame. See **Figure 10**.
3. Replace cover screw to prevent possible gas leakage.
4. Main burners and pilot burner should be checked for signs of corrosion or scale build up.
5. Clean main burners and pilot burner with a steel bristle brush.

Check Venter Static Pressure

Refer to **Figure 18** for the following instructions.

1. With boiler off, disconnect orange and white tubing from pressure switch on air box and venter motor.
2. Install 3/16" (.48 cm) plastic barbed tee between slope manometer and pressure switch.
3. The other part of tee goes to air box and venter pressure taps.
 - A. Orange being high negative.
 - B. White being low negative.
4. Turn boiler back on and read static pressure. Reading should be $-.55 \pm .05$ inches water column or higher for Sealed Combustion series boilers.
5. If static pressures are not at minimum allowable level, check intake and exhaust pipes for obstructions or damage.
6. To reassemble, remove tees and additional tubing and replace orange tube to venter tap, and white tube to air box tap.

7. Do not cut original tubing. Additional tubing is required. If tubing is cut, replace it only with O.E.M. high temperature silicone tubing. Do not replace with vinyl or plastic tubing because it will melt.

CHECK GAS INPUT RATE TO BOILER

1. Maximum permissible gas supply pressure must not be higher and minimum supply pressure must not be lower than what is specified on the rating plate.
2. To check for proper flow of natural gas to boiler using the gas meter, proceed as follows:
 - A. Turn off gas supply to all other appliances, except boiler.
 - B. With boiler operating, determine flow of gas through meter for two minutes and multiply by 30 to get hourly rate.
 - C. Divide input rate shown on rating plate by heating value of gas obtained from local gas company. This will determine number of cubic feet of gas required per hour.
 - D. If minor adjustment is necessary, install manometer on outlet side of gas valve. Adjust pressure regulator on combination gas control. Increase or decrease manifold pressure to obtain gas input required as described on rating plate. To increase, turn regulator adjusting screw clockwise ↻ or counterclockwise ↻ to decrease pressure. See **Figure 10**.
 - E. After adjustment has been completed, turn boiler off and remove manometer and shut-off valve.
 - F. Relight all other appliances turned off in step A above. Be sure all pilot burners are operating.

Figure 18 - Checking Static Pressure

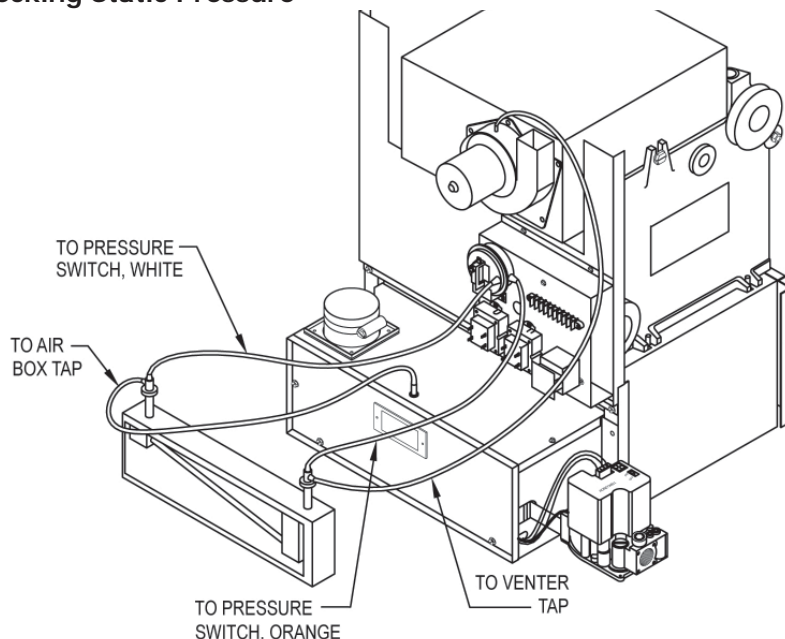

VENTING INSTRUCTIONS

Venting Requirements		Combustion Air Requirements
Boiler Size	Vent Opening Dimensions	3" (8cm) Inlet Pipe length
3 Section	5" X 5" (13 cm x 13 cm)	30 Ft (914cm) with 2 Elbows
4 Section	8" x 8" (20 cm x 20 cm)	30 Ft (914cm) with 2 Elbows
5 Section	9" x 9" (23 cm x 23 cm)	20 Ft (610 cm) with 2 Elbows

Ventilation & Combustion Air

WARNING



Air openings to combustion area must not be obstructed. By following the chart above, adequate combustion air can be maintained.

- This product must be installed by a licensed Plumber or Gas Fitter.
- When flexible connectors are used, the maximum length shall not exceed 36 inches.
- When lever type gas shutoffs are used, they shall be T-handle type.

Figure 19 - Closet Installation

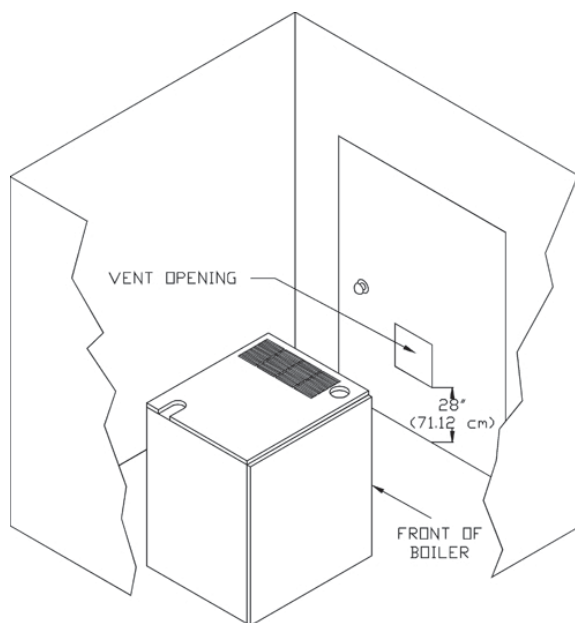

Closet Installation: Vent opening must be placed in wall or door directly across from front of boiler with minimum opening as listed above. Vent opening must be located 28" (71.12 cm) up from floor. See **Figure 19**.

Note: If covering hole with screen or using louvers, opening must have same free flowing area as opening in wall with no screen or louvers.

Installation Requirements Specific To State Of Massachusetts For Direct Vent, Mechanical Vent, and Domestic Hot Water Appliances

In the State of Massachusetts, boiler installation must conform to state code 248 CMR which includes but is not limited to:

For all side wall horizontally vented gas fueled equipment installed in every dwelling, building or structure used in whole or in part for residential purposes, including those owned or operated by the commonwealth and where the side wall exhaust vent termination is less than seven (7) feet above finished grade in the area of the venting including but not limited to, decks and porches, the following requirements shall be satisfied:

1. Installation of carbon monoxide detectors:

At the time of installation of the side wall horizontal vented gas fueled equipment, the installing plumber or gas-fitter shall observe that a hard wired carbon monoxide detector with an alarm and battery back-up is installed on the floor level where the gas equipment is to be installed. In addition, the installing plumber or gas-fitter shall observe that a battery operated or hard wired carbon monoxide detector with an alarm is installed on each additional level of the dwelling, building or structure served by the side wall horizontal vented gas fueled equipment. It shall be the responsibility of the property owner to secure the services of qualified licensed professionals for the installation of hard wired carbon monoxide detectors.

- In the event that the side wall horizontally vented gas fueled equipment is installed in a crawl space or an attic, the hard wired carbon monoxide detector with alarm and battery back-up may be installed on the next adjacent floor level.
- In the event that the requirements of this subdivision can not be met at the time of completion of installation, the owner shall have a period of thirty (30) days to comply with the above requirements; provided, however, that during said thirty (30) day period, a battery operated carbon monoxide detector with an alarm shall be installed.

2. Approved carbon monoxide detectors:

Each carbon monoxide detector as required in accordance with the above provisions shall comply with NFPA 720 and be ANSI/UL 2034 listed and IAS certified.

VENTING INSTRUCTIONS

3. **Signage:** A metal or plastic identification plate shall be permanently mounted to the exterior of the building at a minimum height of eight (8) feet above grade directly in line with the exhaust vent terminal for the horizontally vented gas fueled heating appliance or equipment. The sign shall read, in print size no less than one-half (1/2) inch in size,

GAS VENT DIRECTLY BELOW.

KEEP CLEAR OF ALL OBSTRUCTIONS.

4. **Inspection:** The state or local gas inspector of the side wall horizontally vented gas fueled equipment shall not approve the installation unless, upon inspection, the inspector observes carbon monoxide detectors and signage installed in accordance with the provisions of 248 CMR 5.08(2)(a)1 through 4.
5. **Product-approved vent/air intake:** A product-approved vent terminal must be used and, if applicable, a product-approved air intake must be used. Installation shall be in strict compliance with the manufacturer's instructions.
6. **Installation instructions:** A copy of all installation instructions for all Product Approved side wall horizontally vented gas fueled equipment, all venting instructions, all parts lists for venting instructions, and/or all venting design instructions shall remain with the appliance or equipment at the completion of the installation.

Vent Pipe Installation Instructions

This boiler is design certified for use with following venting systems.

Company	Product
HEAT-FAB®	SAF-T-VENT™
FLEX-L®	STAR-34™
Z-FLEX®	Z-VENT™
ProTech®	FasNSeal™

WARNING

Read and understand these instructions, for correct installation of vent system.

Failure to use this venting system will void manufacturer's warranty and may result in rapid deterioration of venting system, a potential health hazard.



Faulty vent installation can allow toxic fumes to be released into living areas. This may cause serious bodily injury or property damage. Vent performance may also be affected by improper assembly.

Vent connectors serving appliances vented by natural draft shall not be connected into any portion of mechanical draft systems operating under positive pressure

WARNING

All installations of boilers and venting should be done by a qualified expert and in accordance with these instructions. Installing or venting a boiler or any other gas appliance with improper methods or materials may result in serious injury or death due to fire or to asphyxiation from poisonous gases such as carbon monoxide which is odorless and invisible.



CAUTION



The above vent pipe and fittings are used for venting gas burning category III, IV, and direct vent appliances. Do not use this vent pipe or fittings for venting appliances burning fuels such as wood, oil, kerosene or coal.

Do not use this vent pipe and fittings for venting incinerators of any kind.

VENTING INSTRUCTIONS

Figure 2 - Horizontal Vent Piping (Typical Installation)

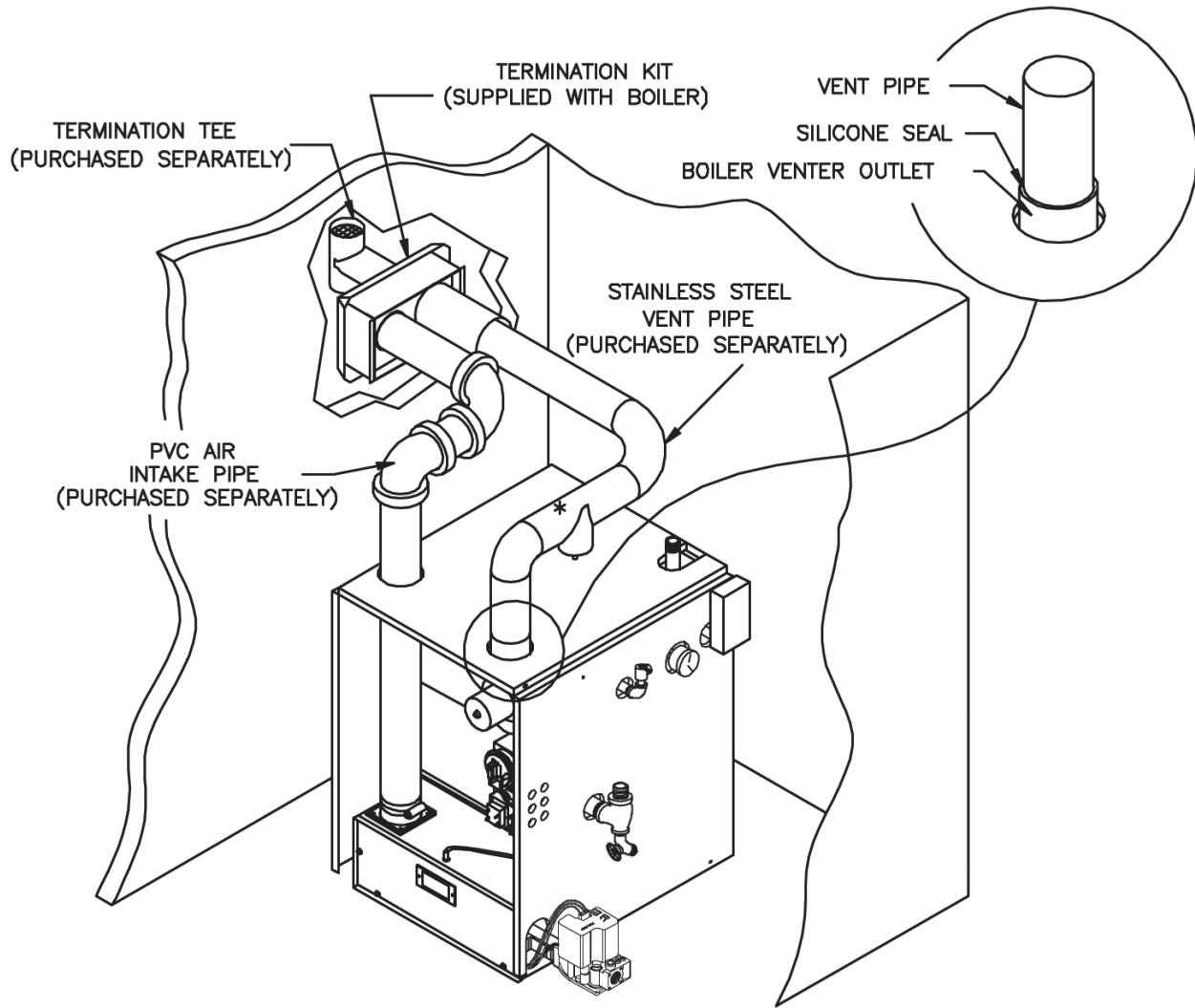

Notes:

- Condensate tee/drain is only needed when horizontal vent lengths exceed 10 feet.
- Insert vent pipe in boiler venter outlet (vent adapter), apply silicone completely around edge of outlet and tighten clamp.

VENTING INSTRUCTIONS

Horizontal Vent Pipe Lengths				
Boiler Size	Vent Pipe Diameter	Max Vent Length*	Min Vent Length*	Inlet Pipe
3 Section	3" (8 cm)	30 ft (914 cm) with condensate tee & 2 elbows.	2 ft (61 cm) with 1 elbow	30 ft (914 cm) with 2 elbows
4 Section	3" (8 cm)	30 ft (914 cm) with condensate tee & 2 elbows.	2 ft (61 cm) with 1 elbow	30 ft (914 cm) with 2 elbows
5 Section	3" (8 cm)	20 ft (610 cm) with condensate tee & 2 elbows.	2 ft (61 cm) with 1 elbow	20 ft (610 cm) with 2 elbows

Example: 20 ft (610 cm) of vent pipe with 1 elbow is equivalent to 15 ft (457 cm) of vent pipe with 2 elbows.

***Note: A condensate trap is only required on models over 10 ft (305 cm) of horizontally run vent piping.**

WARNING



Do not insulate or otherwise wrap vent pipe or fittings. Follow vent pipe manufacturers installation instructions for horizontal venting.

INSTALLATION PROCEDURE FOR VENTING SYSTEM THROUGH A WALL

1. Locate Vent Termination:

Refer to **Figure 9** when determining location of vent outlet.

- A. At least 12 inches (300 mm) above finished grade, or at least 12 inches (300 mm) above normally expected snow accumulation level in geographical areas where snow accumulates. Avoid locations where snow could drift and block vent.
- B. With vent termination clearance of at least 12 inches (300 mm) from any air openings into building.
- C. At least 3 feet (0.9 m) above any forced air inlet located within 10 feet (3 m).
- D. United States - Terminate vent system at least 4 feet (1.22 m) horizontally from, and in no case above or below, unless 4 feet (1.22 m) horizontal distance is maintained, from electric meters, gas meters, regulators and relief equipment.
Canada - Terminate vent system at least 6 feet (1.83 m) horizontally from, and in no case above or below, unless 6 feet (1.83 m) horizontal distance is maintained, from electric meters, gas meters, regulators and relief equipment.
- E. Venting system shall terminate at least 4 feet below any eave, soffit, or roof overhang.
- F. Venting system shall not terminate underneath any deck, patio, or similar structure.
- G. Put vent on wall away from prevailing winter wind.

Locate or guard vent to prevent accidental contact with people or pets.

- H. For horizontal runs; keep a minimum air space clearance from any combustible material, electric wires, and building insulation of 2 inches (.05 m) for 3" (.08 m) vent pipe.
 - I. Horizontal venting shall have slope not less than ¼" per foot (21mm/m) downward away from the boiler to prevent collection of condensate throughout the assembly.
 - J. Do not terminate vent over public walkways or over area where condensate or vapor could be detrimental to regulators, relief valves, or other equipment.
 - K. Do not locate vent termination too close to shrubbery as flue products may stunt growth or kill them.
 - L. Under certain conditions, flue gas will condense, forming moisture. In such cases, steps should be taken to prevent building materials at vent terminal from being damaged by exhaust of flue gas.
 - M. When installing vent cap, secure to noncombustible wall or a combustible wall thimble. Fasten vent cap and seal passage as shown in **Figures 3, 5a and 5b**.
2. Using template provided as guide, cut hole through wall. Secure template to inside of wall over hole. **Figures 5a and 5b.**
NOTE: If installing through non-combustible wall make (2) 3-1/2" (.09 m) holes on center through wall. (Approximately 5-1/4" (13.3 cm) apart on center
3. For venting through non-combustible wall, remove vent termination thimble plate assembly from termination assembly. **Figures 5a and 5b.**

VENTING INSTRUCTIONS

Figure 3 - Front View Of Termination Kit

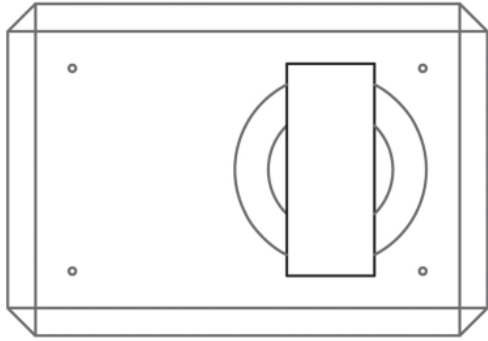
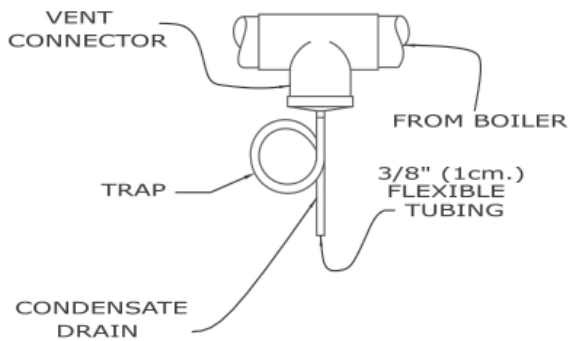

Figure 4 - Condensate Tee & Drain
(Required only if horizontal vent lengths exceed 10' (3 m))



4. Install vent termination assembly through opening and secure to outside wall.
5. Install PVC pipe from vent termination assembly to boilers air inlet.
6. Assemble and install vent pipe according to vent pipe manufacturers instructions.
7. Install vent pipe through termination assembly and extend it 3" (7.6 cm) beyond termination assembly. **Figures 5a and 5b.**
8. Install termination wind deflector with four (4) screws provided. **Figures 5a and 5b.**
9. Install draw collar around pipe and tighten nut and bolt until tightly secured. **Figures 5a and 5b.**
10. Secure termination tee according to vent pipe manufacturers instructions.

Figure 5a - Top View Of Termination Kit And Wall
(For Combustible Wall Installation)

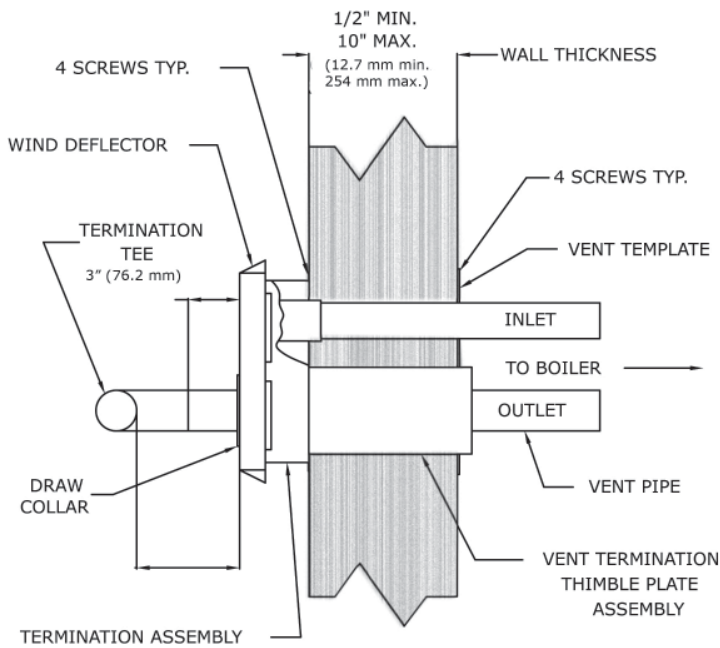
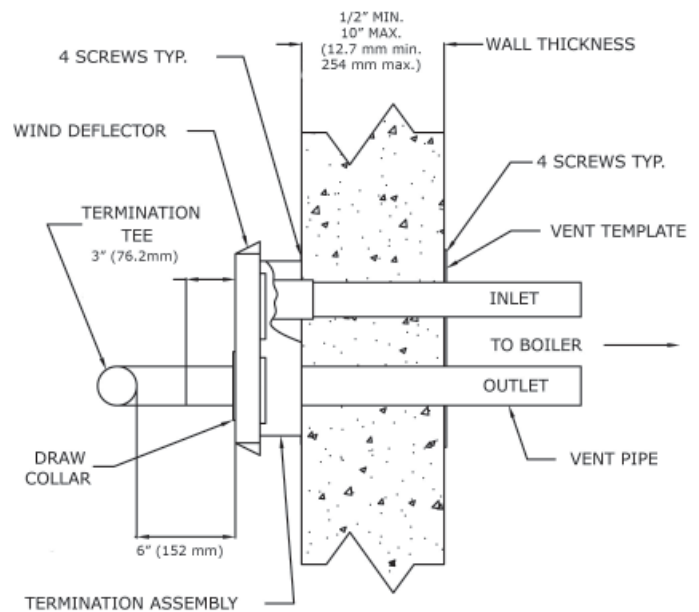

Figure 5b - Top View Of Termination Kit And Wall
(For Non-Combustible Wall Installation Remove Thimble wall Plate Assembly)



VENTING INSTRUCTIONS

For vent pipe installation refer to the vent pipe manufacturers instructions.

Figure 6 - Vent System For All Models

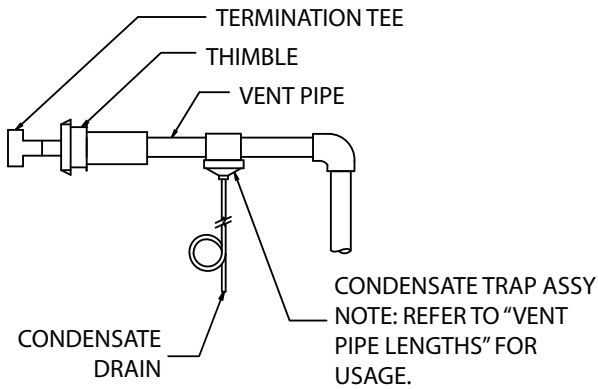

Figure 7 - RECOMMENDED

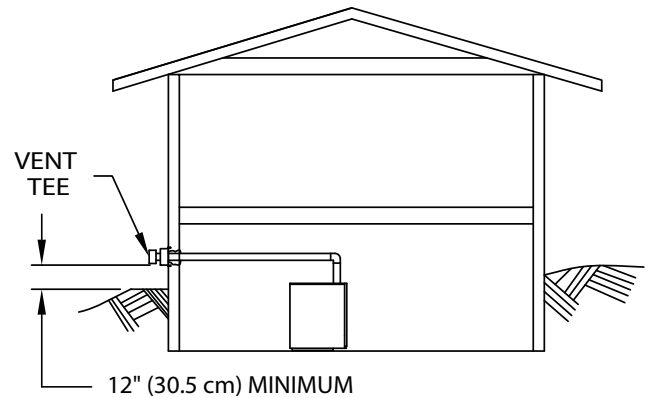
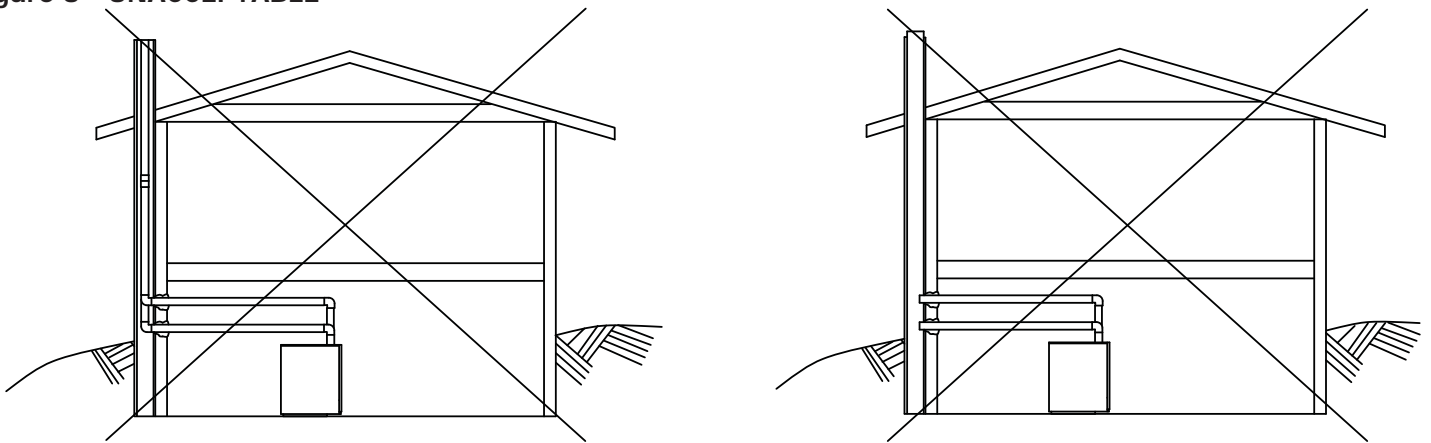

Figure 8 - UNACCEPTABLE



CONDENSATE DRAINS

- Condensate drain is needed when horizontal vent lengths are less than 10 feet (3 m).
- Do not place condensate drain where freezing may occur.
- Condensate drains are required in the vent when using a condensate tee.
- The condensate drain fitting must be plumbed to a sanitary drain for liquid condensate disposal. Condensate drain is plumbed with 3/8" (1 cm) inside diameter flexible tubing. **Figure 4.**
- Refer to "General Instruction For Seasonal Startup and Maintenance", in this manual for maintenance recommendations and schedule.

Flexible Tubing Condensate Drain Installation:

- Install tee with run outlet in vent and close to appliance.
- Install condensate drain in down outlet with high temperature adhesive. **Figure 4.**
- Connect condensate drain outlet to commercially available flexible tubing (minimum length 40" (102 cm)).
- Below drain outlet, make 6" (15.2 cm) diameter loop in 3/8" (1 cm) ID tubing, or 9" (22.9 cm) diameter loop in 5/8" (1.6 cm) ID tubing. Secure loop with plastic cable tie. Run other end of flexible tubing to sanitary drain (Use condensate pump if necessary).
- Fill loop with water before firing boiler.

VENTING INSTRUCTIONS

Figure 9 - Vent Clearances

Note: If there is a potential for excessive winds, special consideration should be given to locate the vent termination away from the windward side of the building.

Vent Cap must be at least 7' (2.13m) above any public walkway

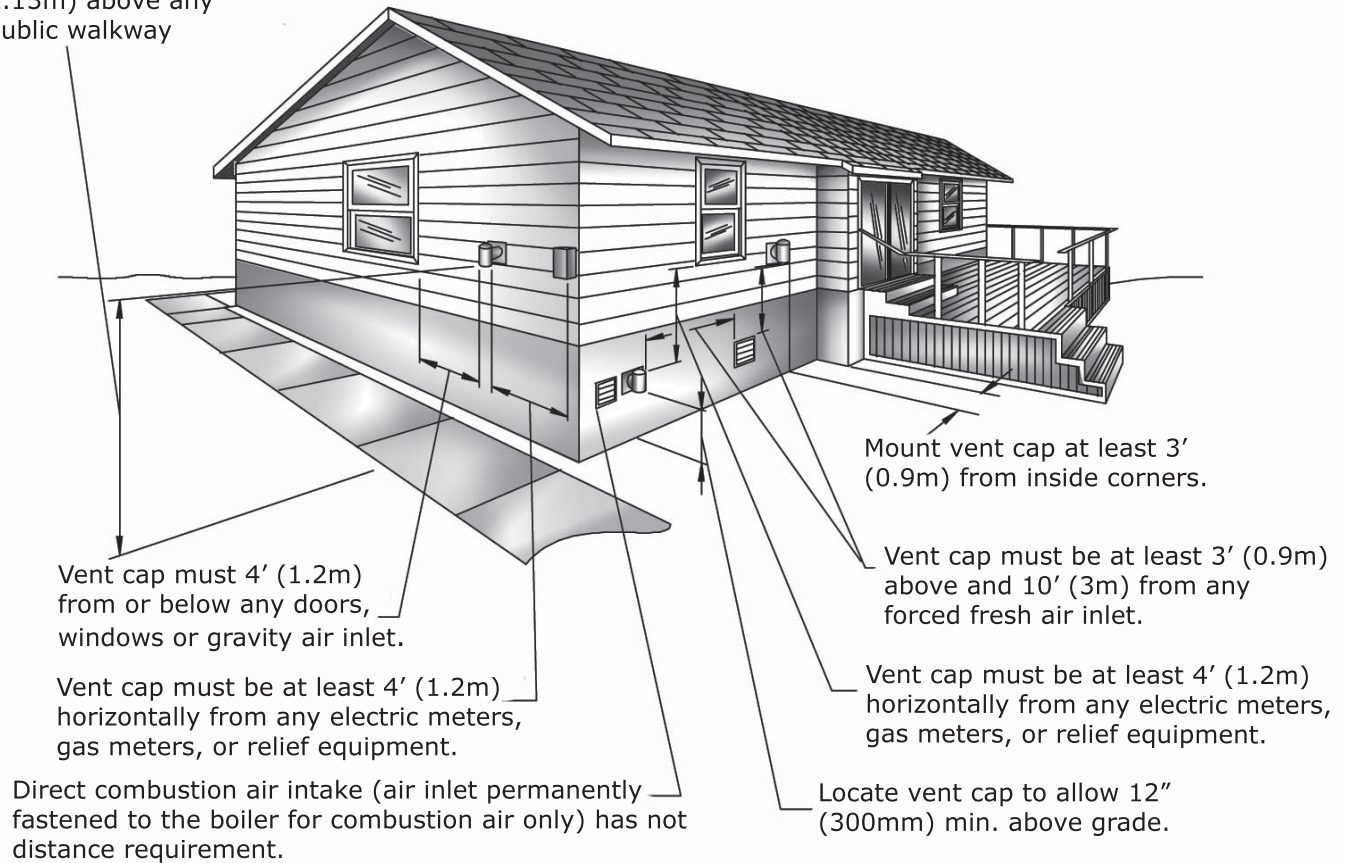

When multiple boilers are used, a clearance of 12" (300 mm) is required between vent caps.

VENTING INSTRUCTIONS

Figure 10 - Flex-L® Star-34™ Vent Pipe Components

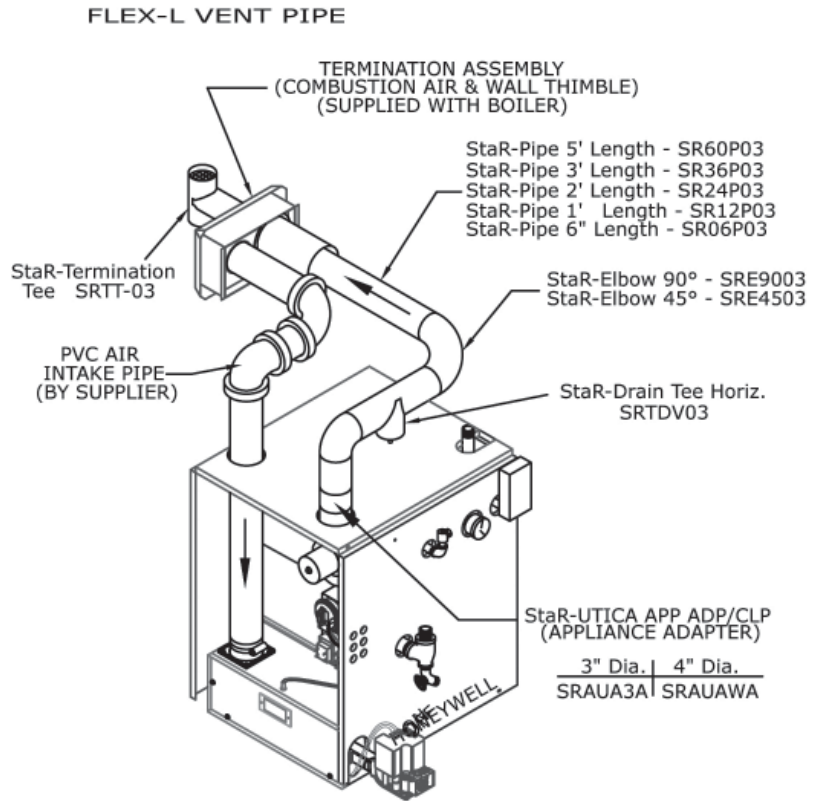

Notes:

- Condensate tee/drain is only needed when horizontal vent lengths exceed 10 feet.
- Insert vent pipe in boiler venter outlet (vent adapter), apply silicone completely around edge of outlet and tighten clamp.

Figure 11 - Heat Fab® Saf-T Vent™ Vent Pipe Components

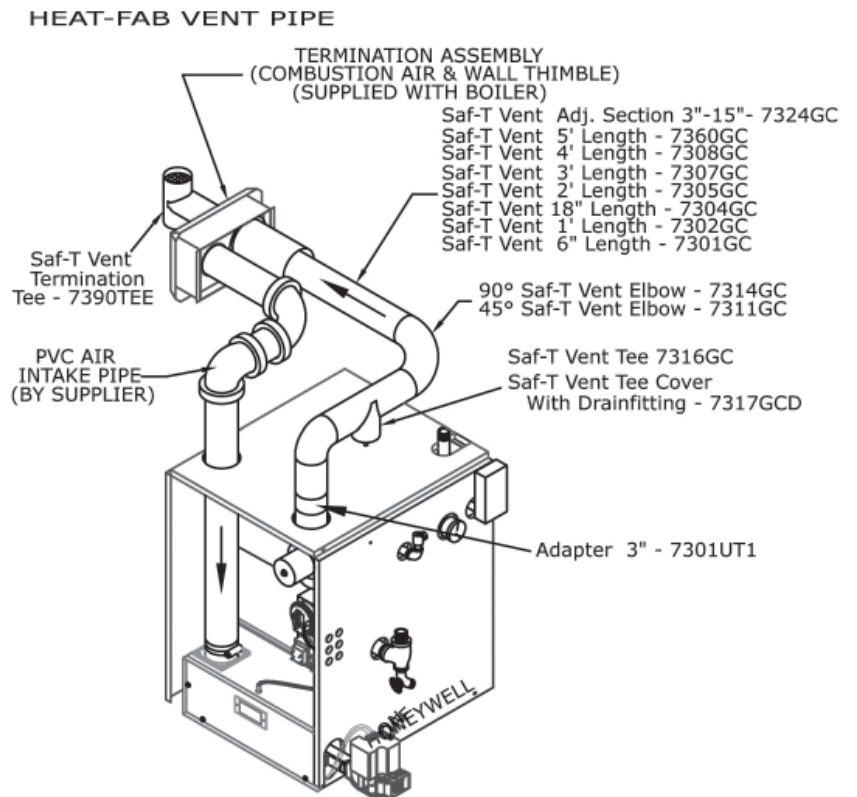

Notes:

- Condensate tee/drain is only needed when horizontal vent lengths exceed 10 feet.
- Insert vent pipe in boiler venter outlet (vent adapter), apply silicone completely around edge of outlet and tighten clamp.

VENTING INSTRUCTIONS

Figure 12 - Z-Flex® Z-vent™ Vent Pipe Components

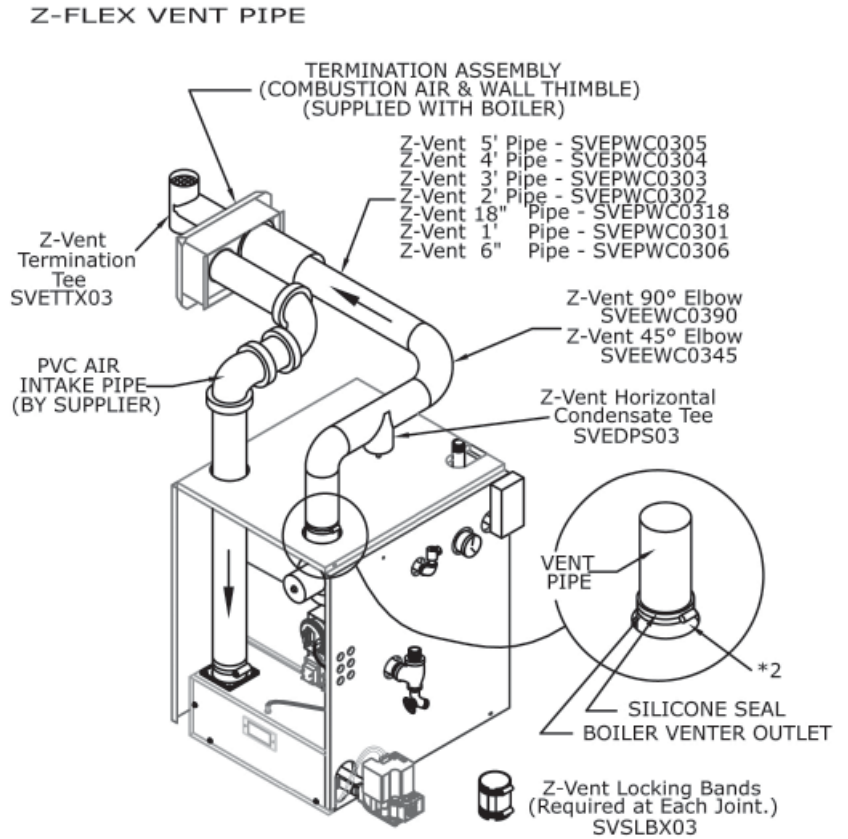

Notes:

- Condensate tee/drain is only needed when horizontal vent lengths exceed 10 feet.
- Insert vent pipe in boiler venter outlet (vent adapter), apply silicone completely around edge of outlet and tighten clamp.

Figure 13 - ProTech® FasNSeal™ Vent Pipe Components

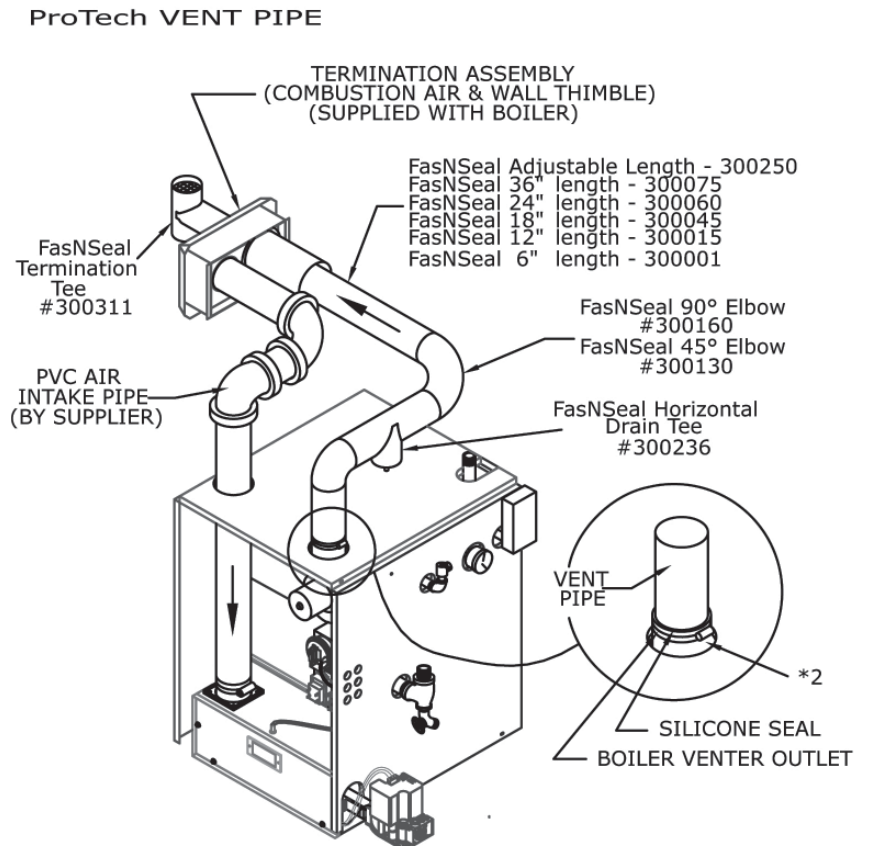

Notes:

- Condensate tee/drain is only needed when horizontal vent lengths exceed 10 feet.
- Insert vent pipe in boiler venter outlet (vent adapter), apply silicone completely around edge of outlet and tighten clamp.

VENTING INSTRUCTIONS

Figure 14 - Vertical Vent Piping Typical Installation

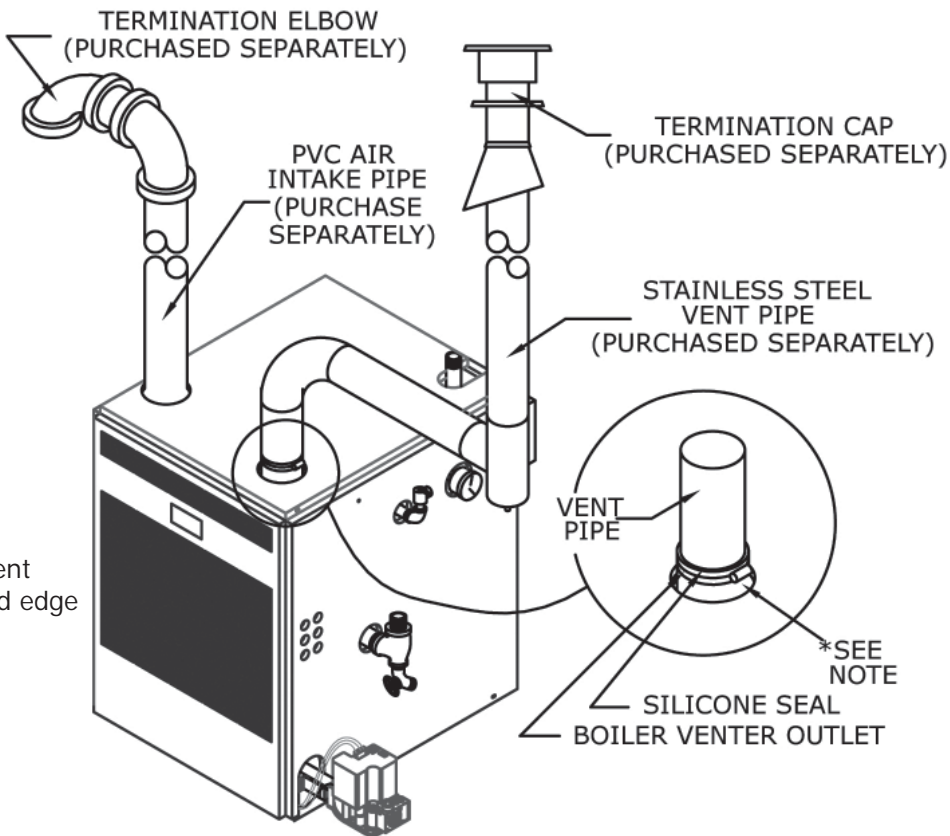

Notes:

- Insert vent pipe in boiler venter outlet (vent adapter), apply silicone completely around edge of outlet and tighten clamp.

Installation Procedure For Vertical Venting

Do not insulate or otherwise wrap vent pipe or fittings. Follow the vent pipe manufacturer's installation instructions for vertical venting.

1. Vent Termination Must Be Located:

- With 2" (51 mm) clearance to combustible materials.
- 4 feet minimum above ridge. **Figure 17**.
- Vent air intake must be 2' (610 mm) below vent outlet and facing away from exhaust outlet. **Figures 17 & 18**.
- Use vent pipe manufacturer's vent cap fire stop, support collar, roof flashing, and storm collar.
- Install vertical vent drain tee. **Figure 15**. See Condensate drain installation section of this manual.
- Fill the 3/8 flexible tubing with water before firing.

- Configuration of vent air intake see **Figure 16**.

Vent Pipe Lengths

- Vent Pipe Diameter: 3" (76 mm)
- Maximum Vent Length: 30 ft (9.1 m) with (1) vertical drain tee, (1) 90° Elbow and (1) Termination Cap. 5 ft (1.5 m) maximum Horizontal.
- Minimum Vent Length: 2 ft (610 mm)
- Inlet Pipe: 30 ft (9.1 m) maximum, 2 ft (610 mm) minimum (4) 90° Elbows (including intake 90° Elbow on roof.)

NOTICE

Boiler installation must use 90° elbow off boiler for horizontal run to the vertical drain tee.

VENTING INSTRUCTIONS

Figure 15 - Vertical Drain Tee

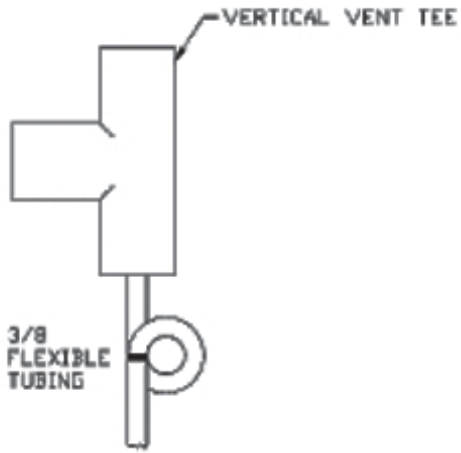

Figure 16 - Vent Air Intake

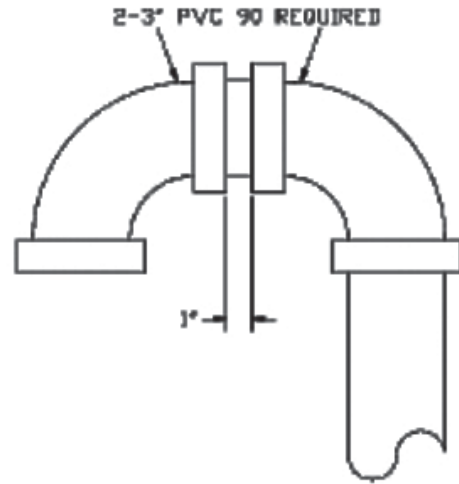

Figure 17 - Termination 10 Ft (3.05 m) or Less From Ridge

* MUST FACE AWAY FROM EXHAUST OUTLET.

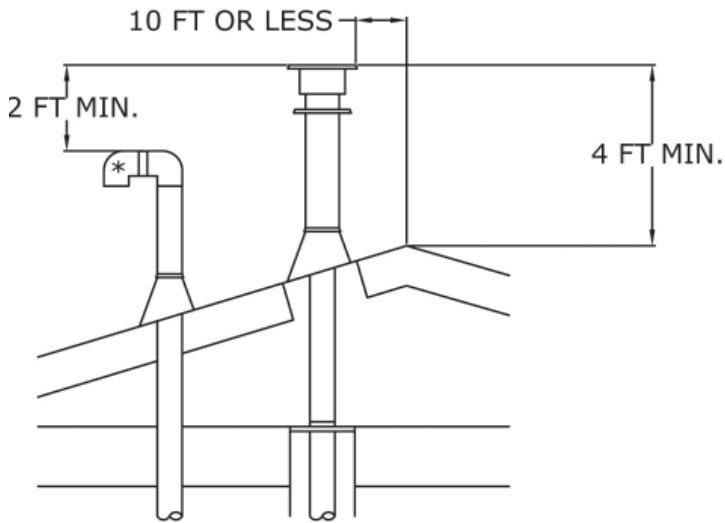
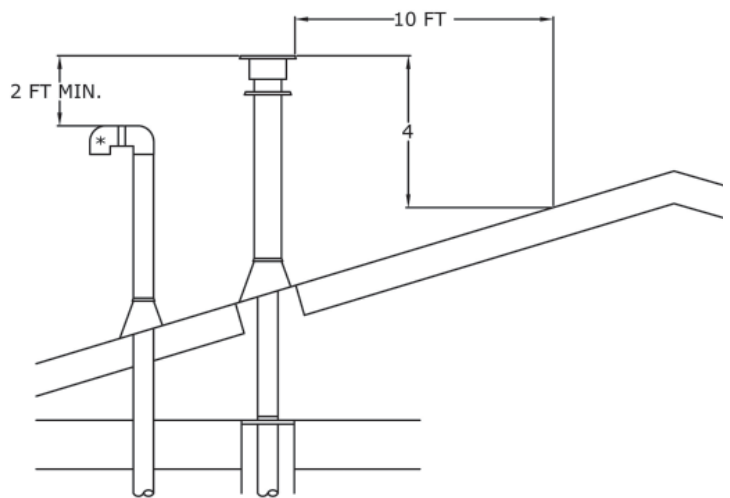

Figure 18 - Termination More than 10 Ft (3.05 m) from Ridge

* MUST FACE AWAY FROM EXHAUST OUTLET.



VENTING INSTRUCTIONS

Figure 19 - Flex-L® Star-34™ Vent Pipe Components

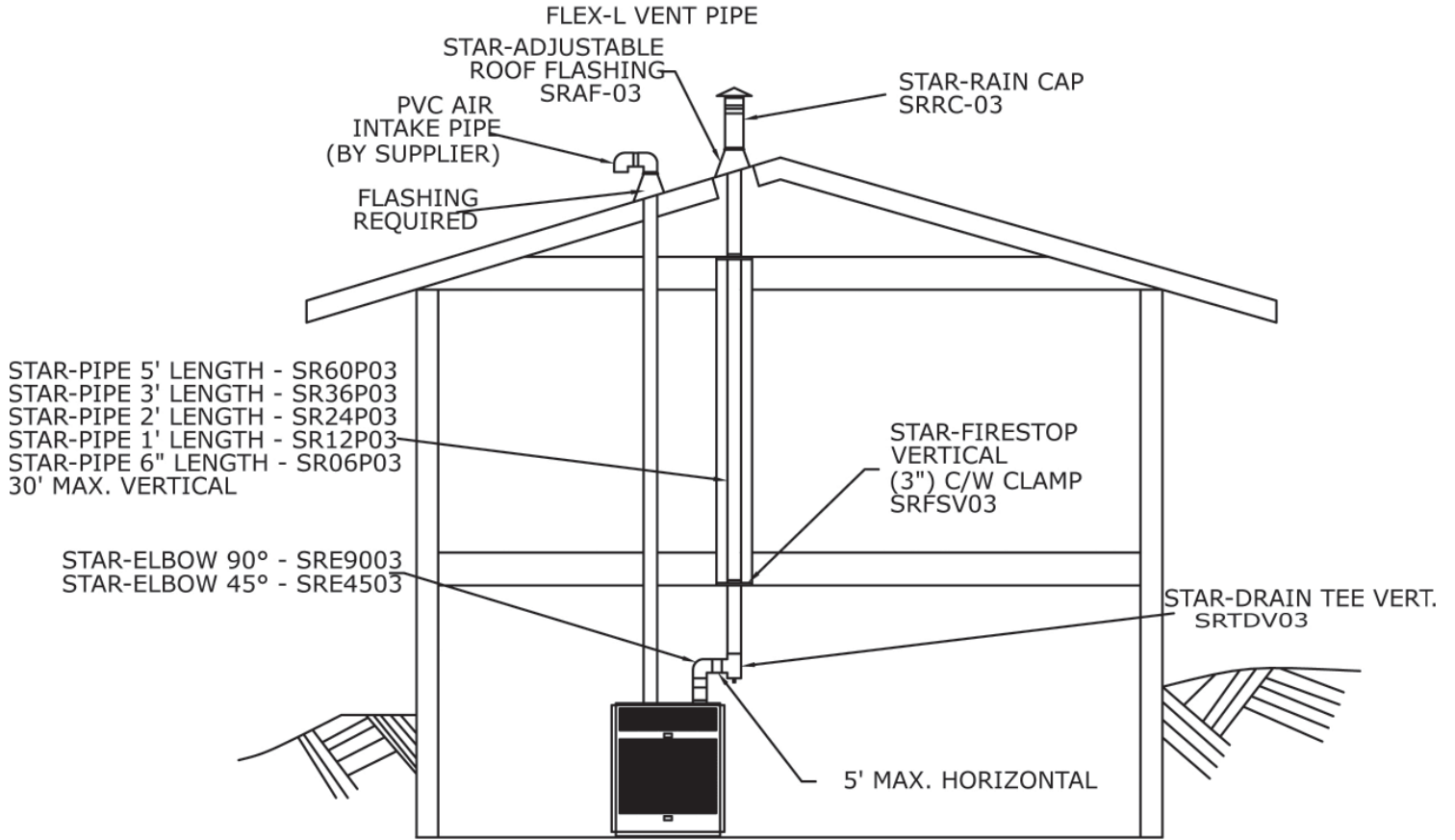
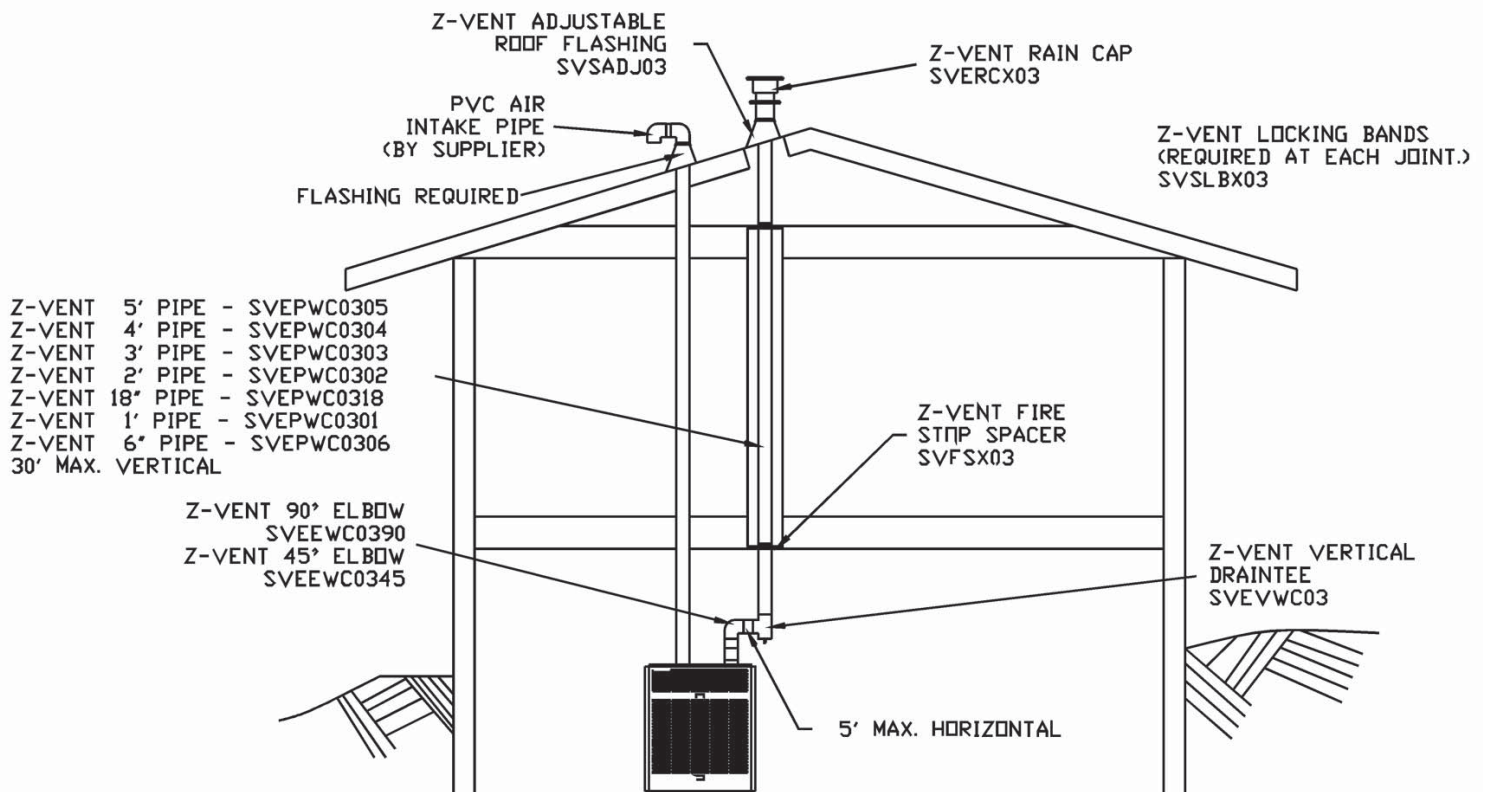

Figure 20 - Z-Flex® Z-vent™ Vent Pipe Components



VENTING INSTRUCTIONS

Figure 21 - Heat Fab® Saf-T Vent™ Vent Pipe Components

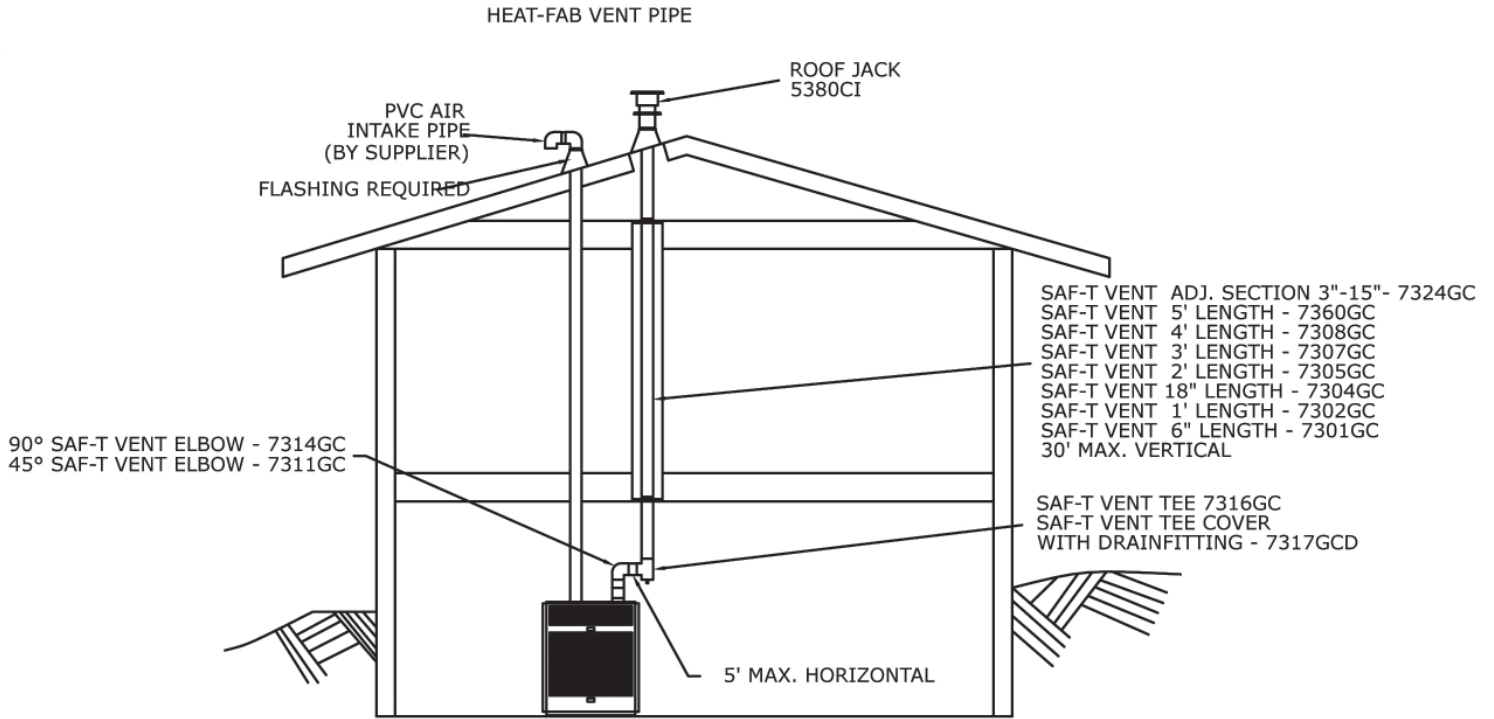
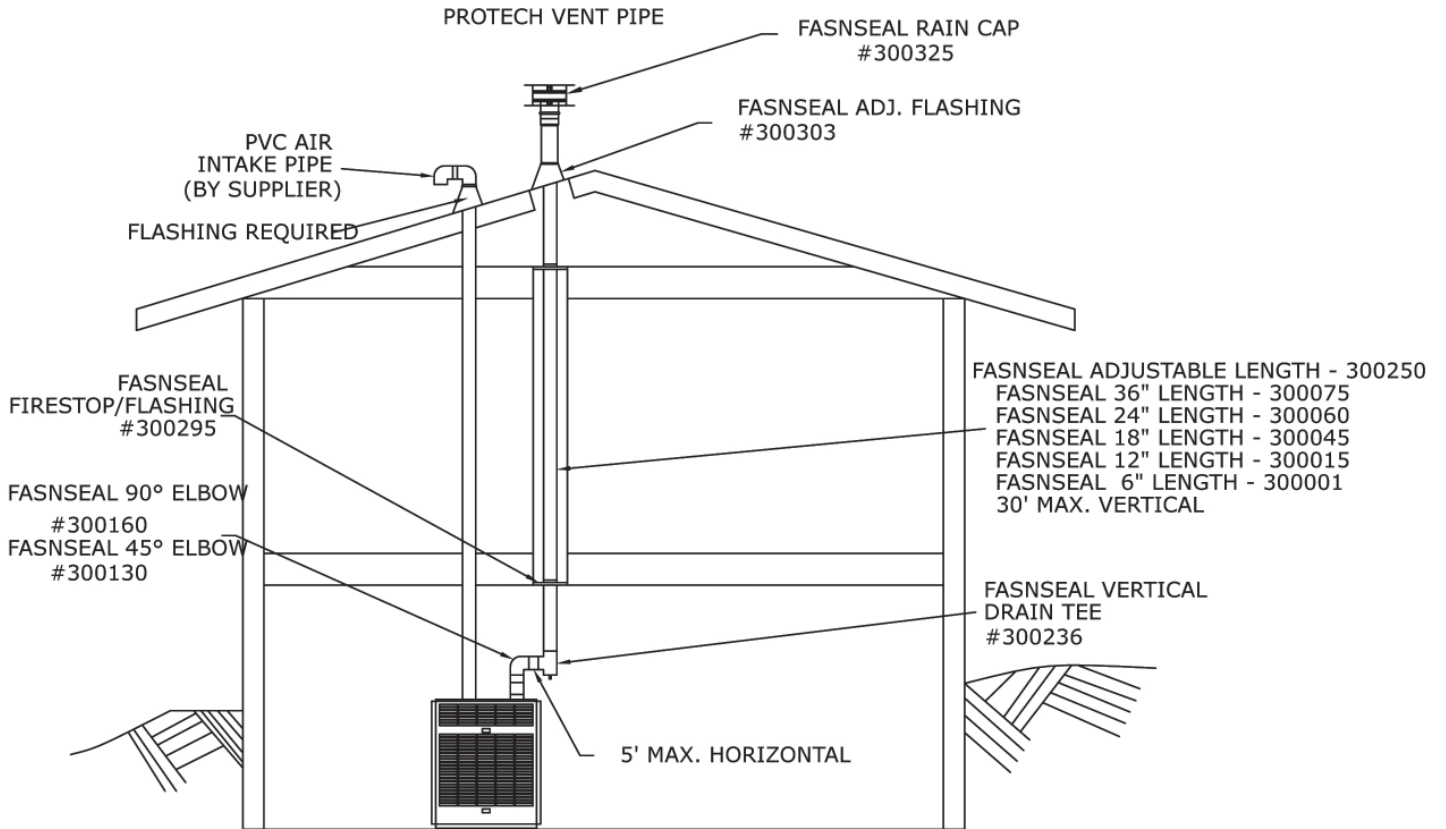

Figure 20 - ProTech® FasNSeal™ Vent Pipe Components



REPLACEMENT PARTS

HEAT EXCHANGER

FULLY ASSEMBLED HEAT EXCHANGERS	
912000002	Heat Exchanger 3 Section
912000003	Heat Exchanger 4 Section
912000004	Heat Exchanger 5 Section

REPLACEMENT PARTS

BASE

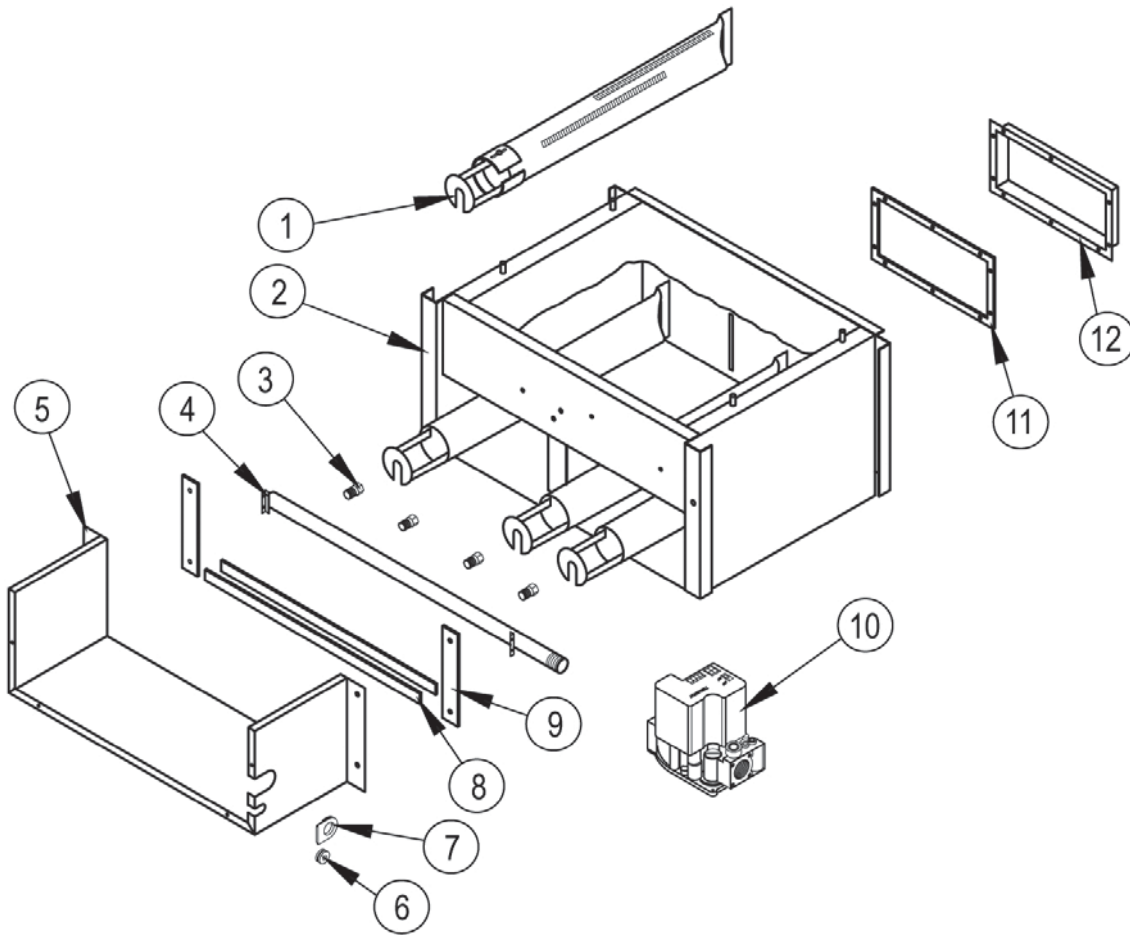

ITEM #	PART #	DESCRIPTIONS	QTY.
1	240005543	Burner Tube 3 Section	2
		Burner Tube 4 Section	3
		Burner Tube 5 Section	4
2	5611602	Kit - Base With Insul 3 Section	1
	5611603	Kit - Base With Insul 4 Section	
	5611604	Kit - Base With Insul 5 Section	
3	355-1-5.09	Orifice #36 5 Section	4
	355-1-5.10	Orifice #37 4 Section	3
	355-1-5.11	Orifice #43 3 Section	2
	355-1-5.12	Orifice #52 4 Section LP	3
	355-1-5.12	Orifice #52 5 Section LP	4
	355-1-5.13	Orifice #54 3 Section LP	2
4	3572201	Manifold 3 Section	1
	3572202	Manifold 4 Section	
	3572203	Manifold 5 Section	

ITEM #	PART #	DESCRIPTIONS	QTY.
5	3272101	Air Box Wrapper 3 Section	1
	3272102	Air Box Wrapper 4 Section	
	3272103	Air Box Wrapper 5 Section	
6	240007769	Pilot Grommet	1
7	HW10201	Manifold Grommet	1
8	3271901	Air Box Wrapper Gskt-Bot 3 Section	2
	3271902	Air Box Wrapper Gskt-Bot 4 Section	
	3271903	Air Box Wrapper Gskt-Bot 5 Section	
9	3271801	Air Box Wrapper Gasket	2
10	(FOR NATURAL GAS ONLY)		
	VG01701	GAS VALVE (SV9501H2417)	1
	(FOR PROPANE GAS ONLY)		
	VG01702	GAS VALVE (SV9501H2425)	1
11	3271501	BRN TUBE COVER INS. 3 Section	1
	3271502	BRN TUBE COVER INS. 4 Section	
	3271503	BRN TUBE COVER INS. 5 Section	
12	32721001	BRN TUBE COVER 3 Section	1
	32721002	BRN TUBE COVER 4 Section	
	32721003	BRN TUBE COVER 5 Section	

REPLACEMENT PARTS

AIR BOX COVERS

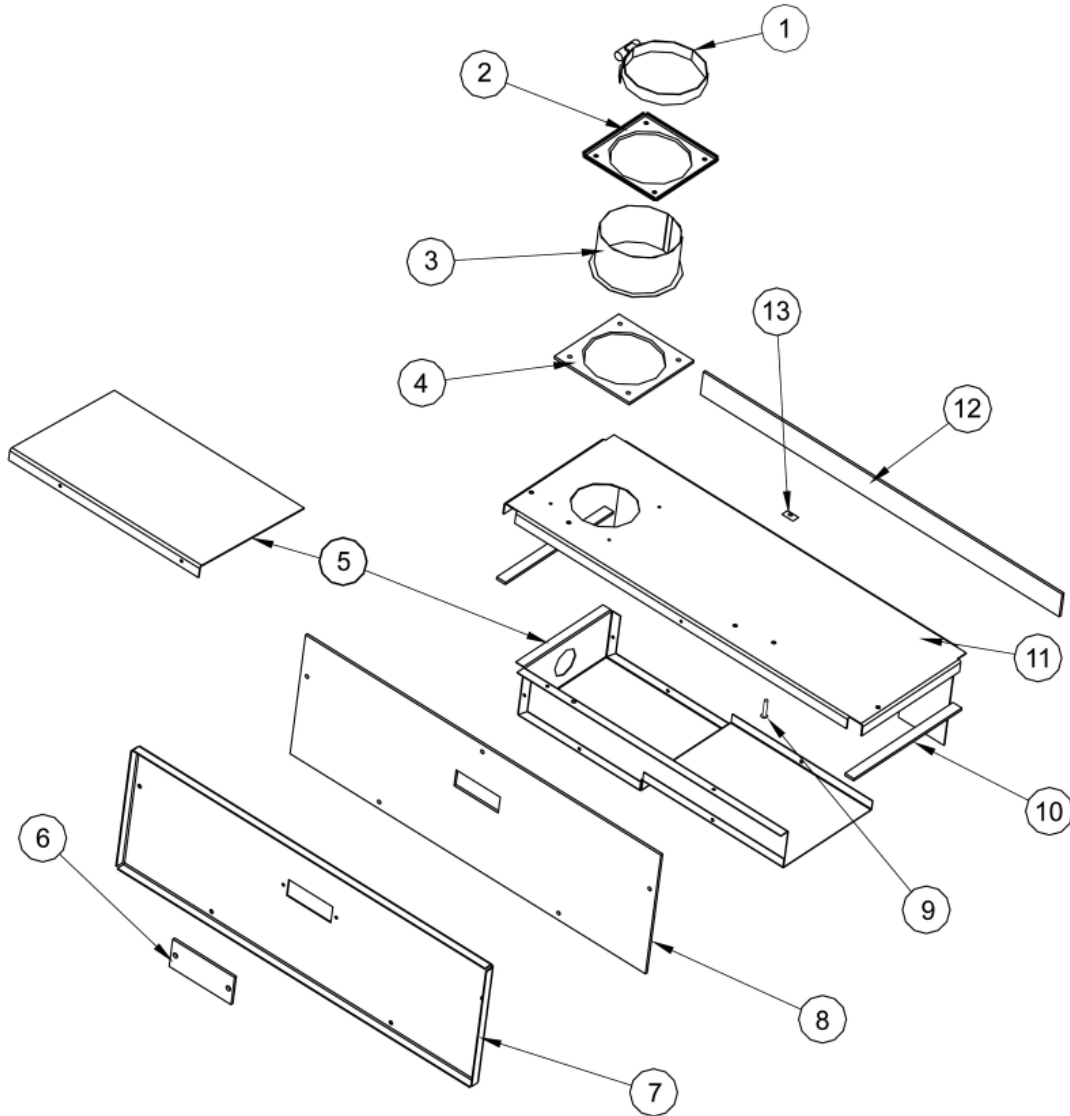

ITEM #	PART #	DESCRIPTIONS	QTY.
1	HW10301	Hose Clamp Sst	1
2	3271601	Air Intake Adapter	1
3	3271203	Air Intake Sleeve	1
4	3271701	Air Intake Adapter Insul	1
5	3271301	Air Deflector 3 Section	1
	32721501	Intake Box Assy 4 Section	
	32721502	Intake Box Assy 5 Section	
6	3571201	Base Obs. Window	1
7	3272701	Air Box Frt Pnl Assy 3 Section	1
	3272702	Air Box Frt Pnl Assy 4 Section	
	3272703	Air Box Frt Pnl Assy 5 Section	
(Includes Obs. Window, #9, & Insul #11)			

ITEM #	PART #	DESCRIPTIONS	QTY.
8	3572401	Insul Frt Cov. 3 Section	1
	3572402	Insul Frt Cov. 4 Section	
	3572403	Insul Frt Cov. 5 Section	
9	HW10001	Air Box Tap 2230 RI	1
10	3572304	Insul Air Box Cover	2
11	3272401	Air Box Cover Assy 3 Section	1
	3272402	Air Box Cover Assy 4 Section	
	3272403	Air Box Cover Assy 5 Section	
(Includes Insulation #12 & # 13, And Air Box Tap #6 & Washer #7)			
12	3572301	Insul Air Box Cov. 3 Section	1
	3572302	Insul Air Box Cov. 4 Section	
	3572303	Insul Air Box Cov. 5 Section	
13	HW09901	Lock Washer	1

REPLACEMENT PARTS

PIPING & CONTROLS

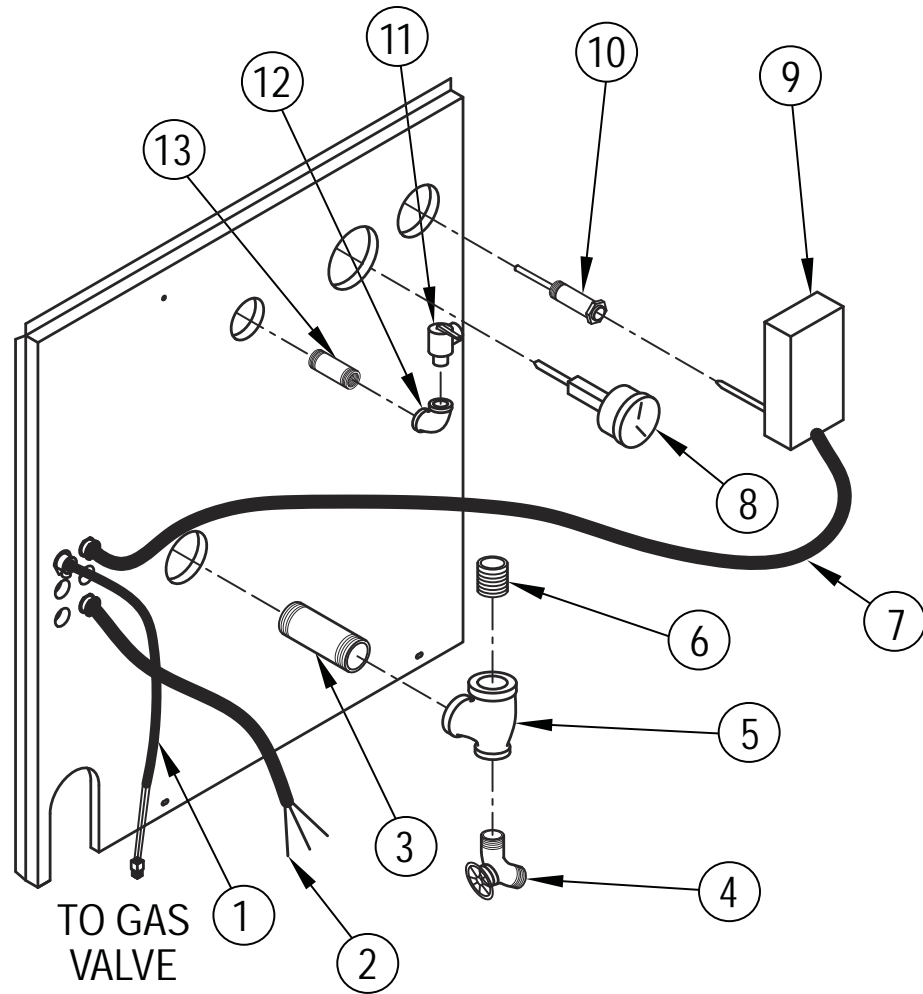

ITEM #	PART #	DESCRIPTIONS	QTY.
1	3772301	WIRE HARNESS - GAS VALVE 28"	1
2	37519501	HARNESS CIRCULATOR 72"	1
3	1310002	PIPE - NIPPLE 1.1/4 X 4.1/2 NPT	1
4	HW-016.03	DRAIN SHORT	1
5	1510001	PIPE FIT TEE - 1.1/4X3/4X1.1/4	1
6	PF-006.01	PIPE FIT NIPPLE 1.1/4 CLOSE	1
7	37518901	HARNESS - CONTROL TO LIMIT	1
8	1260006	GAUGE-THERALTIMETER	1
9	AQ02201	CONTROL - LIMIT L4080B-1212 HW	1
10	AQ-020.01	WELL 3/4 X 3 HW	1
11	VR-001.01	RELIEF VALVE 30# 3/4"	1
12	1190001	PIPE FIT ELBOW 3/4 NPT 90°	1
13	1310001	PIPE - NIPPLE 3/4 X 4 NPT	1

REPLACEMENT PARTS

ELECTRICAL

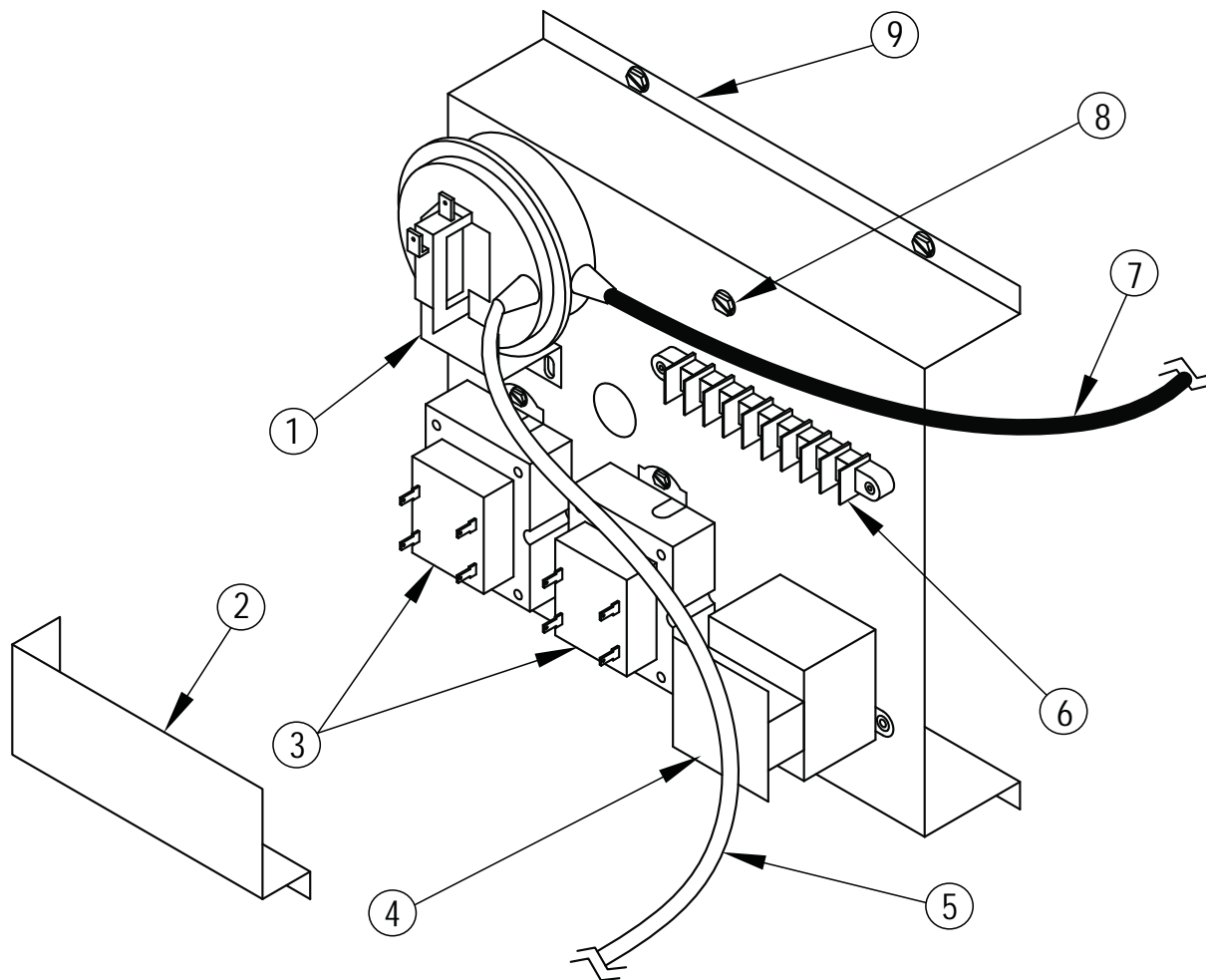

ITEM #	PART #	DESCRIPTIONS	QTY.
1	SS00801	PRESSURE SWITCH (FS6205A)	1
2	3171101	TERMINAL STRIP COVER	1
3	550001339	TRANSFORMERS - 40VA	2
4	1410001	CONTROL R8222C-1008	1
5	HW09601	TUBING - SILICON - CLEAR	12"
6	EF04001	9 TERM STRIP	1
7	HW09701	TUBING - SILICON - ORANGE	17"
8	HW09001	SCREW 10-32X5/16 GREEN GROUND	1
9	3172701	PANEL CONTROL SUPPORT BRACKET	1
	3772201	COMPLETE CONTROL BRACKET ASSEMBLY (THIS INCLUDES PART # 1,2,3,5,7,8, & ALL WIRING)	1

REPLACEMENT PARTS

PILOT

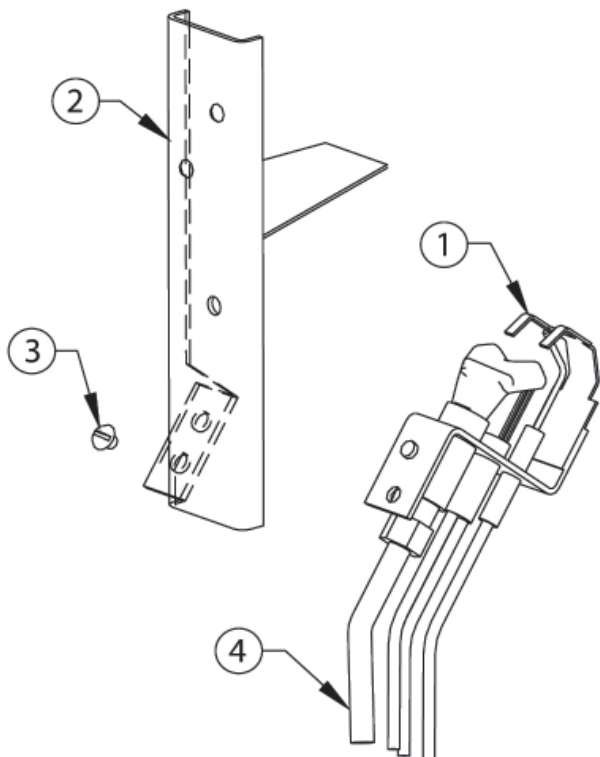

ITEM #	PART #	DESCRIPTION	QTY.
1	PBO1401	Pilot Q3450b 1039 HW NAT (For Natural Gas Only)	1
	PB01402	Pilot Q3450b 1112 LP (For Propane Gas Only)	
2	3771101	Pilot Assembly	1
3	HW-024.01	Screw #10 32x3/16	1
4	43300201	Pilot Tube 1/8"X24" Aluminum	1

FLUE COLLECTOR & VENTER COMPONENTS

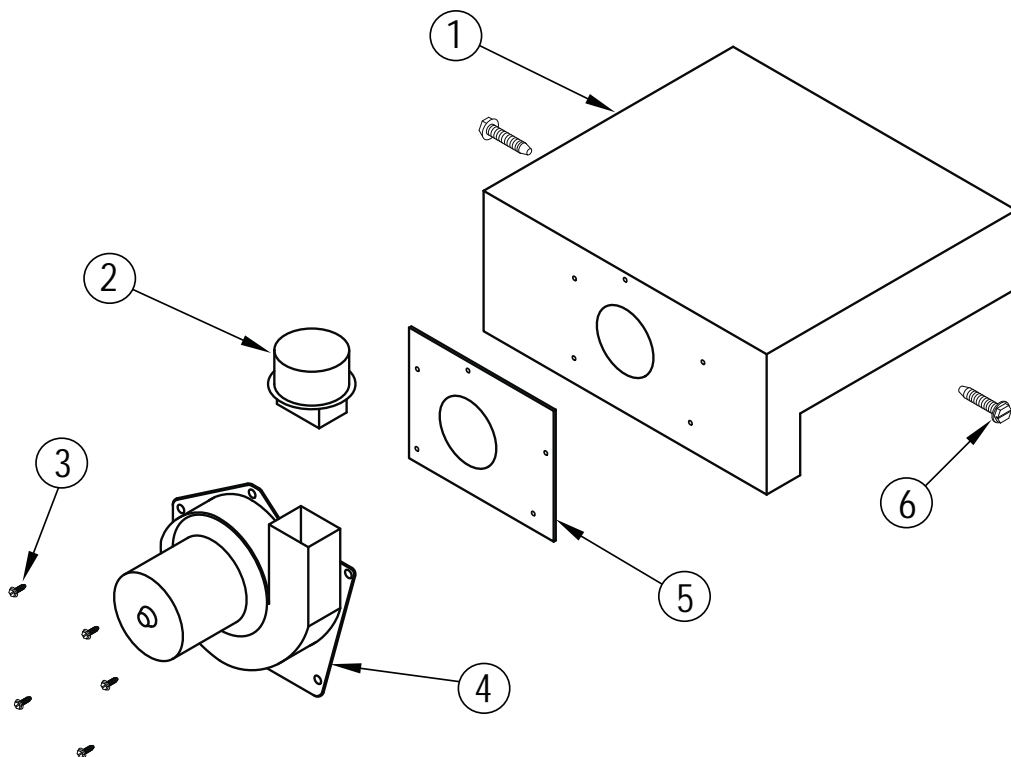

ITEM #	PART #	DESCRIPTIONS	QTY.
1	3472501	FLUE COLLECTOR ASSY 3 Section	1
	3472502	FLUE COLLECTOR ASSY 4 Section	
	3472503	FLUE COLLECTOR ASSY 5 Section	
2	345-2-7.01	VENT ADAPTER	1
3	HW-005.01	SCREW 1/4-20X1/2 SELF TAP	5
4	DC00402	VENTER - JAKEL	1
5	3571501	GASKET - VENTER	1
6	14695039	BOLT 5/16"-18X1.1/2" TYPE F	2

REPLACEMENT PARTS

TERMINATION KIT

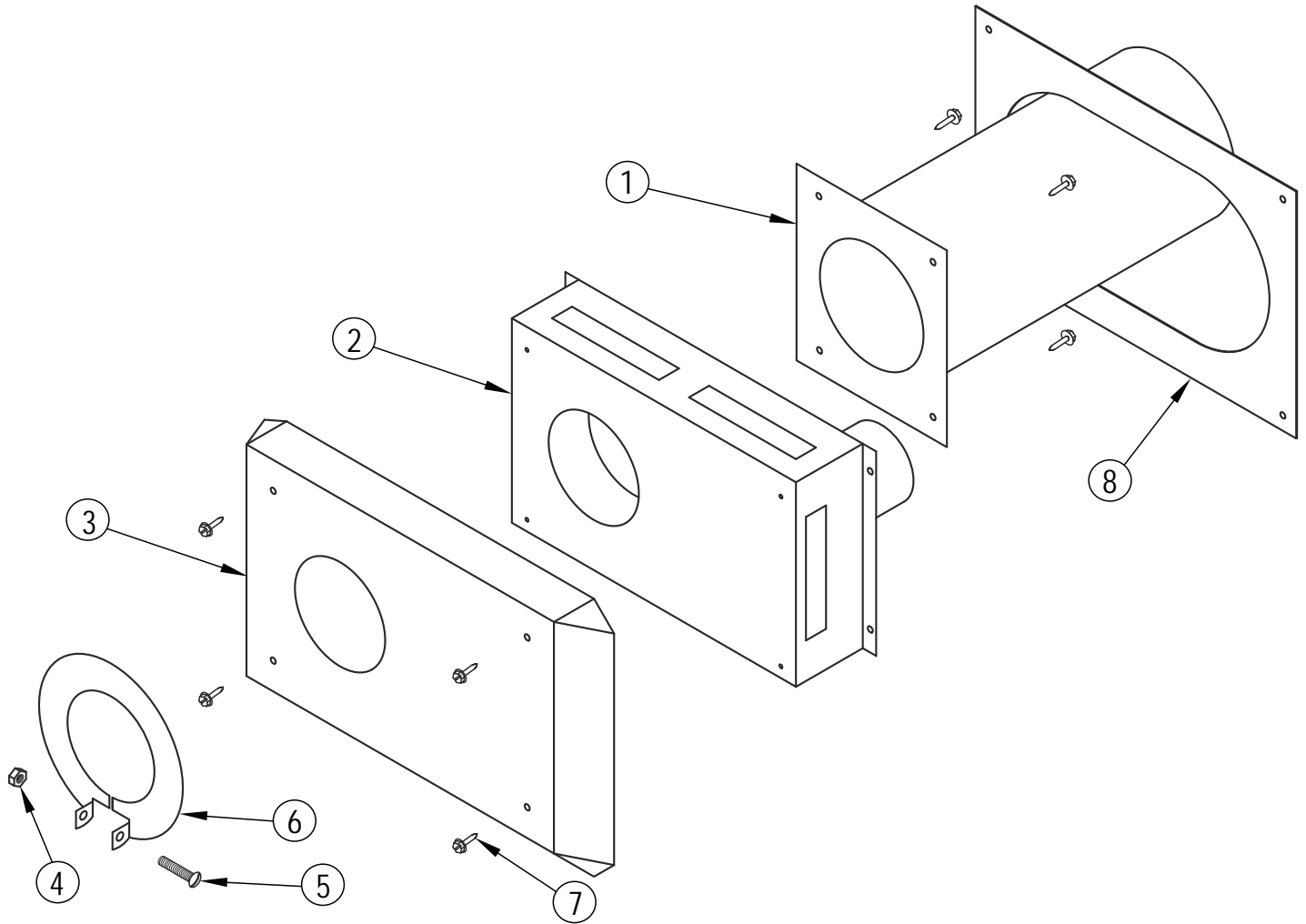

ITEM #	PART #	DESCRIPTIONS	QTY.
1	34721501	VENT TERMINATION THIMBLE PLATE ASSY	1
2	34721002	TERMINATION ASSEMBLY	1
3	34721401	VENT TERMINATION DEFLECTOR	1
4	1330006	NUT #10-24 HEX	1
5	30A004312	SCREW #10-24 X 1.1/2" ROUND HEAD	1
6	3471701	DRAW COLLAR -	1
7	HW-009.01	SCR #8-18X1/2" SLT HX WASH	8
8	3471901	VENT TEMPLATE	1
5612601		TERMINATION KIT (INCLUDES ALL OF THE ABOVE)	

OSC - SERIES REPLACEMENT PARTS

JACKET

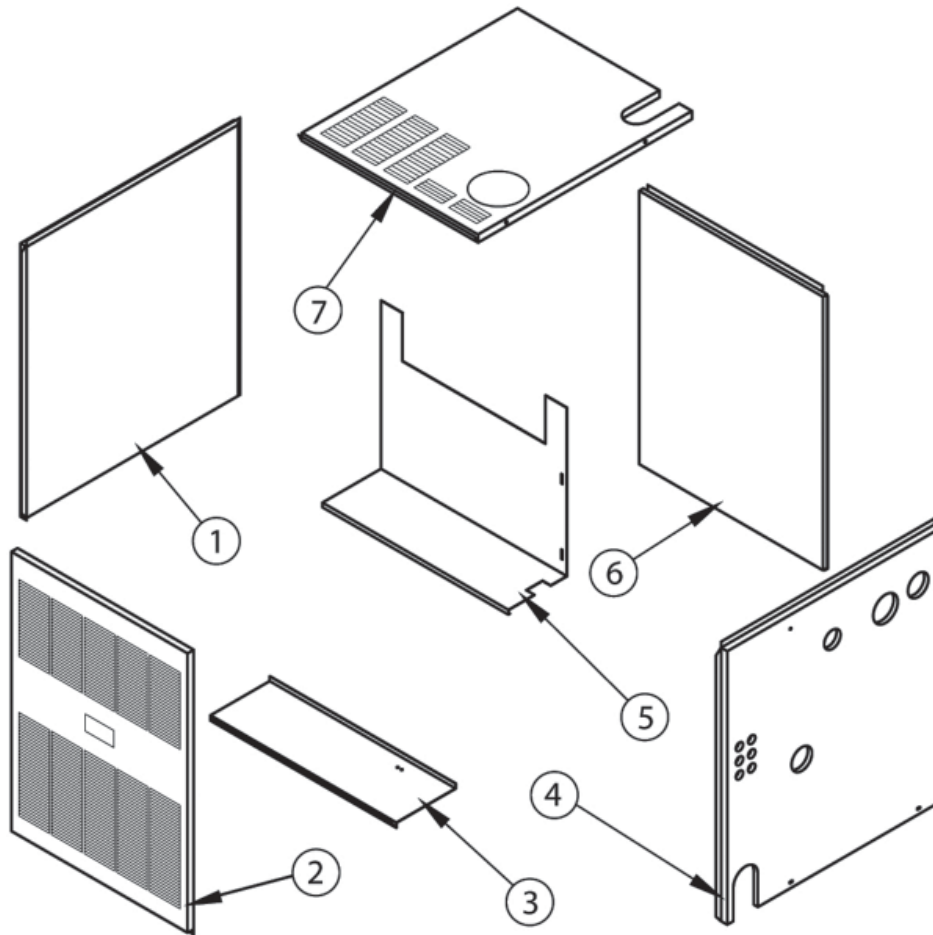

ITEM	DESCRIPTION	PART NUMBER	QTY.
1	Panel - Left 50-200	3162702	1
2	Panel - Front OSC-50	315-2-19.01	1
	Panel - Front OSC-100	315-2-19.02	
	Panel - Front OSC-125 & 150	315-2-19.03	
	Panel - Front OSC-200	315-2-19.04	
3	Panel - Base OSC-50	315-2-12.01	1
	Panel - Base OSC-100	315-2-12.02	
	Panel - Base OSC-125 & 150	315-2-12.03	
	Panel - Base OSC-200	315-2-12.04	
4	Panel - Right OSC-50-200	3162701	1
5	Panel - Separator OSC-50	31522401	1
	Panel - Separator OSC-100	31522402	
	Panel - Separator OSC-125 & 150	31522403	
	Panel - Separator OSC-175 & 200	31522404	

RELIEF VALVE PIPING

Supplemental Installation Instructions

IMPORTANT: THIS MANUAL MUST BE KEPT NEAR THE BOILER FOR FUTURE REFERENCE!!

WARNINGS AND SAFETY SYMBOLS



DANGER

Indicates an imminently hazardous situation which, if not avoided, WILL result in death, serious injury.



CAUTION

Indicates an imminently hazardous situation which, if not avoided, may result in injury .



WARNING

Indicates an imminently hazardous situation which, if not avoided, may result in death, serious injury.

NOTICE

Indicates information which should be followed to ensure proper installation and operation.

NOTICE

Following instructions are to be used with Installation, Operation & Maintenance Manual received with your boiler and are supplemental to "Supply and Return Piping " section.



WARNING

To avoid burns, scalding, or water damage due to discharge of steam and/or hot water during operation, a discharge line shall be installed to relief valve outlet connection.

Discharge line shall:

- connect to relief valve outlet and piped down to safe point of disposal. Check local codes for maximum distance from floor or allowable safe point of discharge.
- be of pipe size equal to or greater than that of the relief valve outlet over the entire length of discharge line;
- have no intervening shutoff valve between safety relief valve and discharge to atmosphere (do not plug or place any obstruction in discharge line.
- terminate freely to atmosphere where any discharge will be clearly visible and at no risk of freezing;
- allow complete drainage of the valve and the discharge line;
- be independently supported and securely anchored to avoid applied stress on the relief valve;
- be as short and straight as possible;
- terminate with plain end (not threaded);
- be constructed of material suitable for exposure to temperatures of 375° F; or greater.

Refer to local codes and appropriate ASME Boiler and Pressure Vessel Code for additional installation requirements.

Relief Valve and Discharge Line Piping Installation

Install relief valve on pipe nipple in tapped boiler opening. Pipe discharge line following guidelines in preceding Warning. Refer to examples shown in Figures 1 & 2.

Discharge line pipe size shall be equal or greater than that of relief valve outlet over entire length of discharge line with no intervening shutoff valve between safety relief valve and discharge to atmosphere.

Discharge line shall terminate with plain end (not threaded) to atmosphere where any discharge will be clearly visible and is at no risk of freezing.

Discharge line shall be independently supported to avoid applied stress on relief valve. Installation shall allow complete drainage of relief valve and discharge line.

Discharge line shall be as short and straight as possible and constructed of material suitable for exposure to temperatures of 375° F, or greater.

Refer to local codes and appropriate ASME Boiler and Pressure Vessel Code for additional installation requirements.

Figure 1

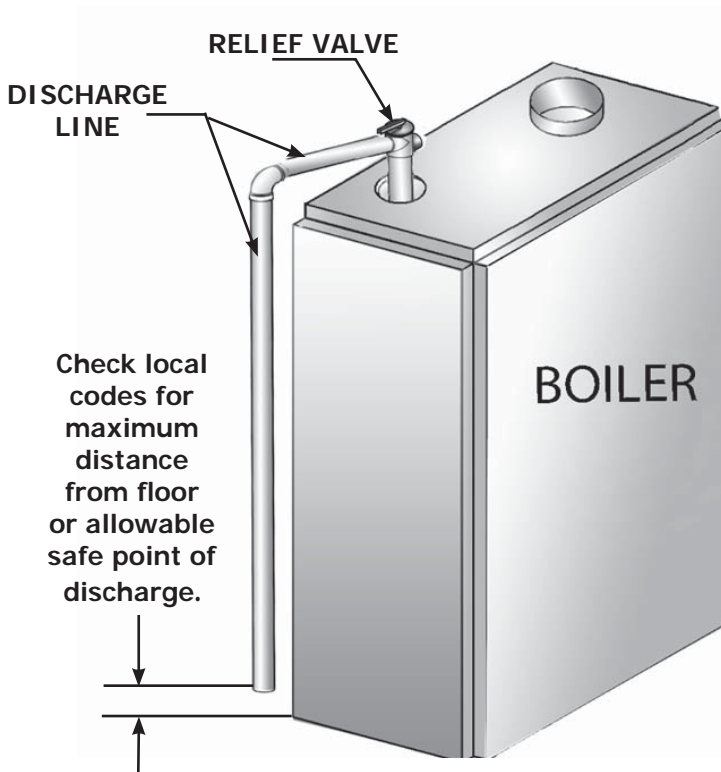

Figure 2

