

USER'S INFORMATION MANUAL SERIES CSC GAS FIRED HOT WATER HEATING BOILER

WARNING: If the information in this manual is not followed exactly, a fire or explosion may result causing property damage, personal injury or loss of life.

- Do not store or use gasoline or other flammable vapors and liquids in the vicinity of this or any other appliance.

- WHAT TO DO IF YOU SMELL GAS
 - Do not try to light any appliance.
 - Do not touch any electrical switch; do not use any phone in your building.
 - Immediately call your gas supplier from a neighbor's phone. Follow the gas supplier's instructions.
 - If you cannot reach your gas supplier, call the fire department.

- Installation and service must be performed by a qualified installer, service agency or the gas supplier.

Do not use this boiler if any part has been under water. Immediately call a qualified service technician to inspect the boiler and to replace any part of the control system and any gas control which has been under water.

Should overheating occur or the gas supply fail to shut off, do not turn off or disconnect the electrical supply to the pump. Instead, shut off the gas supply at a location external to the appliance.

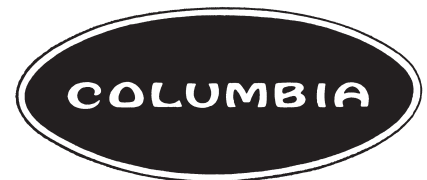

COLUMBIA BOILER COMPANY
Main offices and Factory:
Pottstown, PA

P/N 37711901, Rev. A [8/2011]

INSTRUCTIONS FOR OPERATION AND MAINTENANCE
OF GAS FIRED HOT WATER HEATING BOILER

RETAIN FOR FUTURE REFERENCE

SAFETY SYMBOLS & WARNINGS

The following defined symbols are used throughout this manual to notify the reader of potential hazards of varying risk levels.

Utica Boilers recommends all boiler maintenance be performed by a trained heating technician.

Before any procedures are attempted on this appliance, it is necessary to determine if the ignition system is a electric or standing pilot system. If you are uncertain, contact the manufacturer before proceeding.



DANGER

Indicates a hazardous situation which, if not avoided, WILL result in death or serious injury.



CAUTION

Indicates a hazardous situation which, if not avoided, may result in minor or moderate injury.



WARNING

Indicates a hazardous situation which, if not avoided, could result in death or serious injury.

NOTICE

Indicates information which should be followed to ensure proper installation and operation.

LIGHTING INSTRUCTIONS

WARNING



Before lighting any type of pilot burner (standing or intermittent), make certain the hot water boiler and system are full of water to minimum pressure of 12 psi in the system, and also make certain that the system is vented of air. Refer to the following appropriate lighting instruction.

LIGHTING PROCEDURE FOR BOILER WITH INTERMITTENT PILOT SYSTEM

WARNING



If you do not follow these instructions exactly, a fire or explosion may result causing property damage, personal injury or loss of life.

- A. This appliance is equipped with an ignition device which automatically lights the pilot. Do not try to light the appliance by hand.
- B. Before operating, smell all around the appliance area for gas. Be sure to smell next to the floor because some gas is heavier than air and will settle on the floor. Read *"What To Do If You Smell Gas"* on front page of this manual.
- C. Use only your hand to move ignition system control switch. Never use tools. If the switch will not move by hand, don't try to repair it, call a qualified service technician. Force or attempted repair may result in a fire or explosion.
- D. Do not use this appliance if any part has been under water. Immediately call a qualified service technician to inspect the appliance and to replace any part of the control system and any gas control which has been under water.

OPERATING INSTRUCTIONS FOR INTERMITTENT PILOT SYSTEM

1. **STOP!** Read safety information above.
2. Set thermostat to lowest setting.
3. Turn off all electric power to appliance.
4. This appliance is equipped with ignition device which automatically lights the pilot. Do not try to light pilot by hand.
5. Move ignition control switch to "OFF." See figure 1.
6. Wait (5) minutes to clear out any gas. If you then smell gas, **STOP!** Follow *"What To Do If You Smell Gas"* on front cover of this manual. If you don't smell gas, go on to the next step.
7. Move ignition control switch to "ON."
8. Turn on all electric power to appliance.
9. Set thermostat to desired setting.
10. If appliance will not operate, follow instructions *"To Turn Off Gas To Appliance"* on page 1 and call qualified service technician or your gas supplier.

Figure 1 - Intermittent Pilot

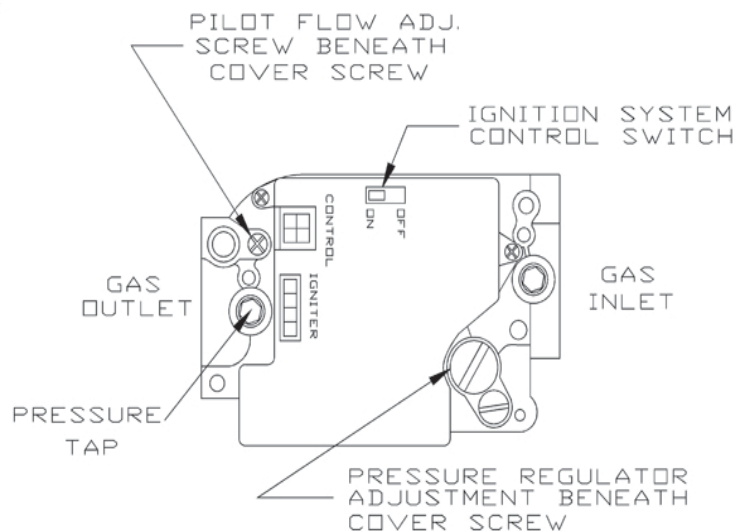

LIGHTING INSTRUCTIONS

To Turn Off Gas To Appliance

1. Set the thermostat to lowest setting.
2. Turn off all electric power to the appliance if service is to be performed.
3. Move ignition system control switch to "OFF."
4. Replace access panel.

GENERAL INSTRUCTIONS

Before seasonal start-up, have a qualified service agency check boiler for soot and scale in flue passageways and clean burners.

Venting system should also be inspected at start of each heating season. Vent pipe from boiler should be checked for signs of deterioration or sagging joints. Repair if necessary.

Following procedure should be followed to clean and check flue gas passageways:

1. Turn off gas to boiler at manual gas valve.
2. Remove jacket front panel. See figure 2.
3. Disconnect vent pipe from vent adapter.
4. Disconnect air inlet pipe from coupling. See figure 5.
5. Remove air box covers. See figure 5.
6. Remove burners from combustion chamber by raising burners up from manifold orifices and pulling toward front of boiler. See figure 3.
7. Remove top panel. See figure 2.
8. Remove flue collector and venter assembly from boiler castings by removing hold-down screws located on each side of flue collector. See figure 4.

Figure 2 - Front Jacket Panel

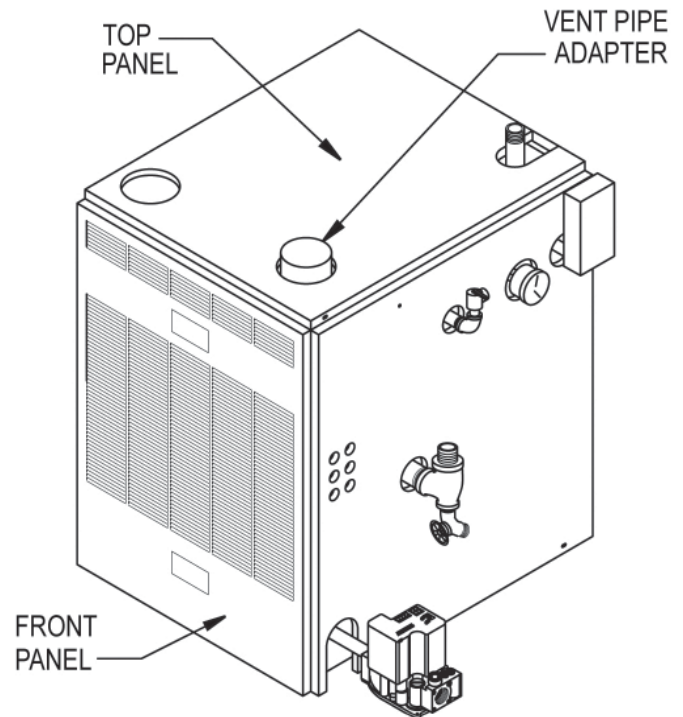
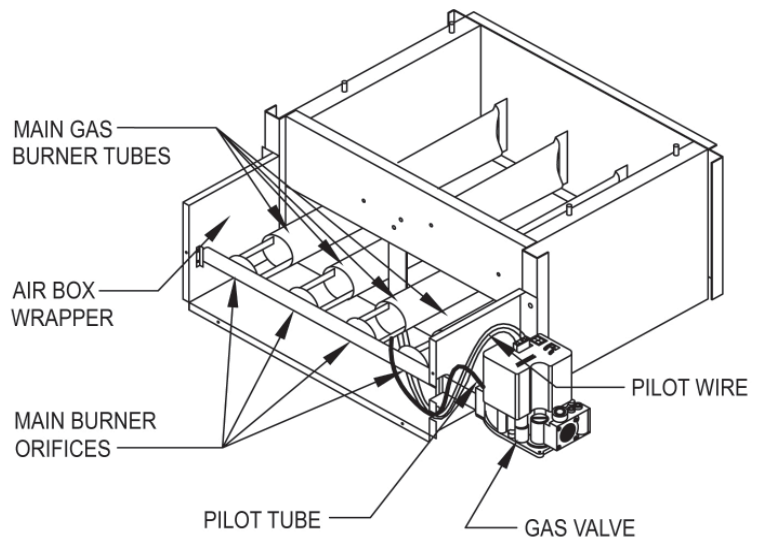
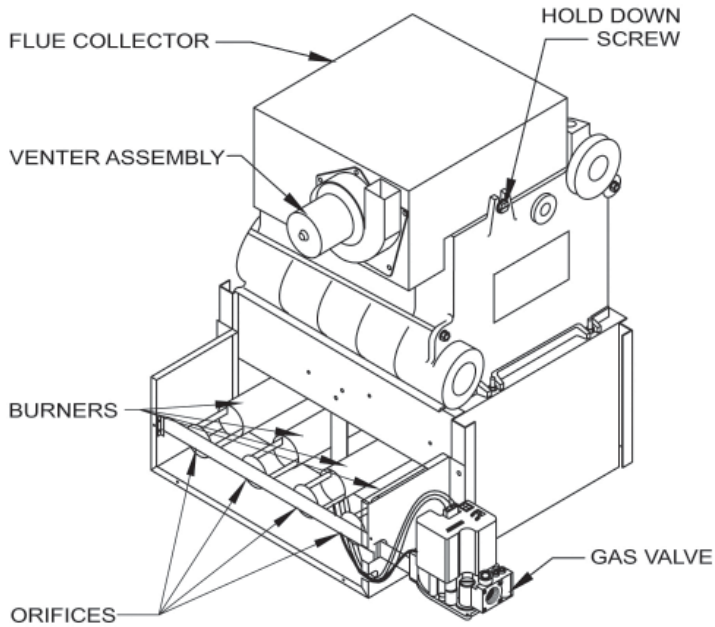

Figure 3 - Gas Burner Tubes



GENERAL INSTRUCTIONS

Figure 4 - Flue Collector



9. Remove baffles from heat exchanger. See figure 5.
10. Visually inspect baffles for any unusual wear or soot build up.
11. Visually inspect venter assembly for any unusual wear or dirt build up.
12. Place sheet of heavy paper or similar material in bottom of combustion chamber and brush down flue passageways. Soot and scale will collect on paper and is easily removed with paper.
13. Replace Flue Collector using hold down screws and silicone in place with GE IS 808 silicone. See figure 4.
14. Execute steps 1-9 in reverse order to reassemble boiler.

Figure 5 - Heat Exchanger

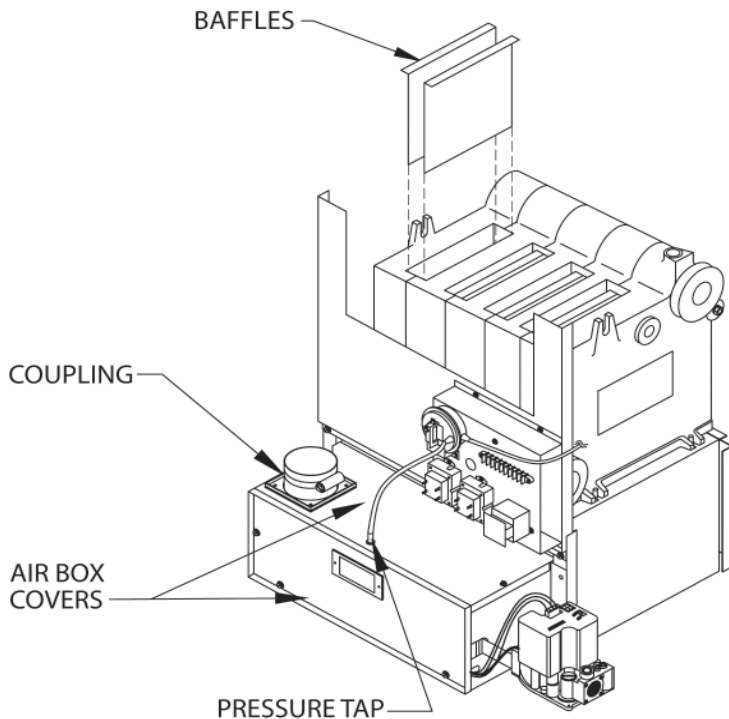

GENERAL INSTRUCTIONS



- Visual check of main burner and pilot flames should be made at start of the heating season and again in mid-season.
- Main burner flame should have well defined inner blue mantel with lighter blue outer mantel. If flame does not appear this way, check burner throats and burner orifices for lint or dust obstructions. See figure 6.
- Pilot flame should envelop $\frac{3}{8}$ to $\frac{1}{2}$ inch of tip of ignition electrode. To adjust pilot flame, remove pilot adjustment cover screw on gas valve and turn inner screw clockwise  to decrease or counterclockwise  to increase pilot flame. Replace cover screw after adjustment to prevent possible gas leakage. (See figures 1, 7 & 8 below.)
- Check burners and pilot for signs of corrosion, rust or scale buildup. Clean with nylon bristle brush.
- Keep area around boiler clear and free of combustible materials, gasoline and other flammable vapors and liquids.
- Free flow of combustion and ventilating air to boiler and boiler room **must not** be restricted or blocked.
- In event flow of combustion products through flueways or boiler venting system becomes blocked, pressure switch or ignition system will shut off main burner gas. If this condition occurs, do not attempt to place boiler in operation. Contact qualified service agency.
- Annual inspection of boiler and heating system should be done by qualified service agency. They are experienced in making inspection outlined above and in event repairs or corrections are necessary, they can make proper changes for safe operation of boiler.

Figure 6 - Main Burner Flame

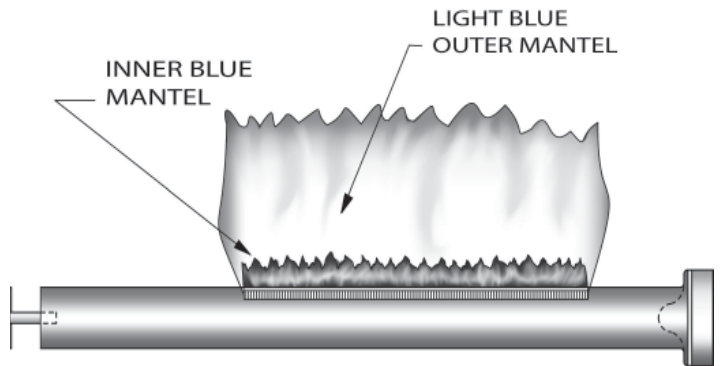
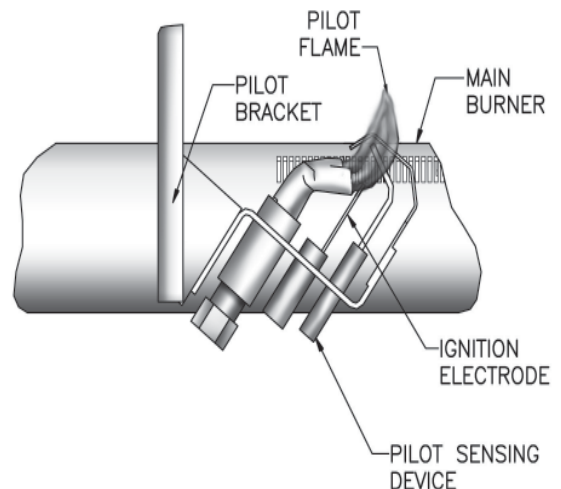
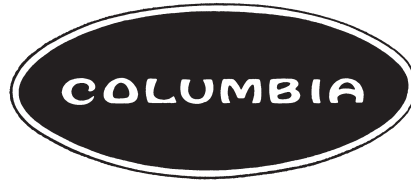

Figure 7 - Pilot Flame





COLUMBIA BOILER COMPANY

Main offices and Factory: Pottstown, PA

Date of Installation:

Boiler Model #: _____

Installed By: _____
