

USC

DIRECT VENT GAS FIRED BOILERS FOR FORCED HOT WATER

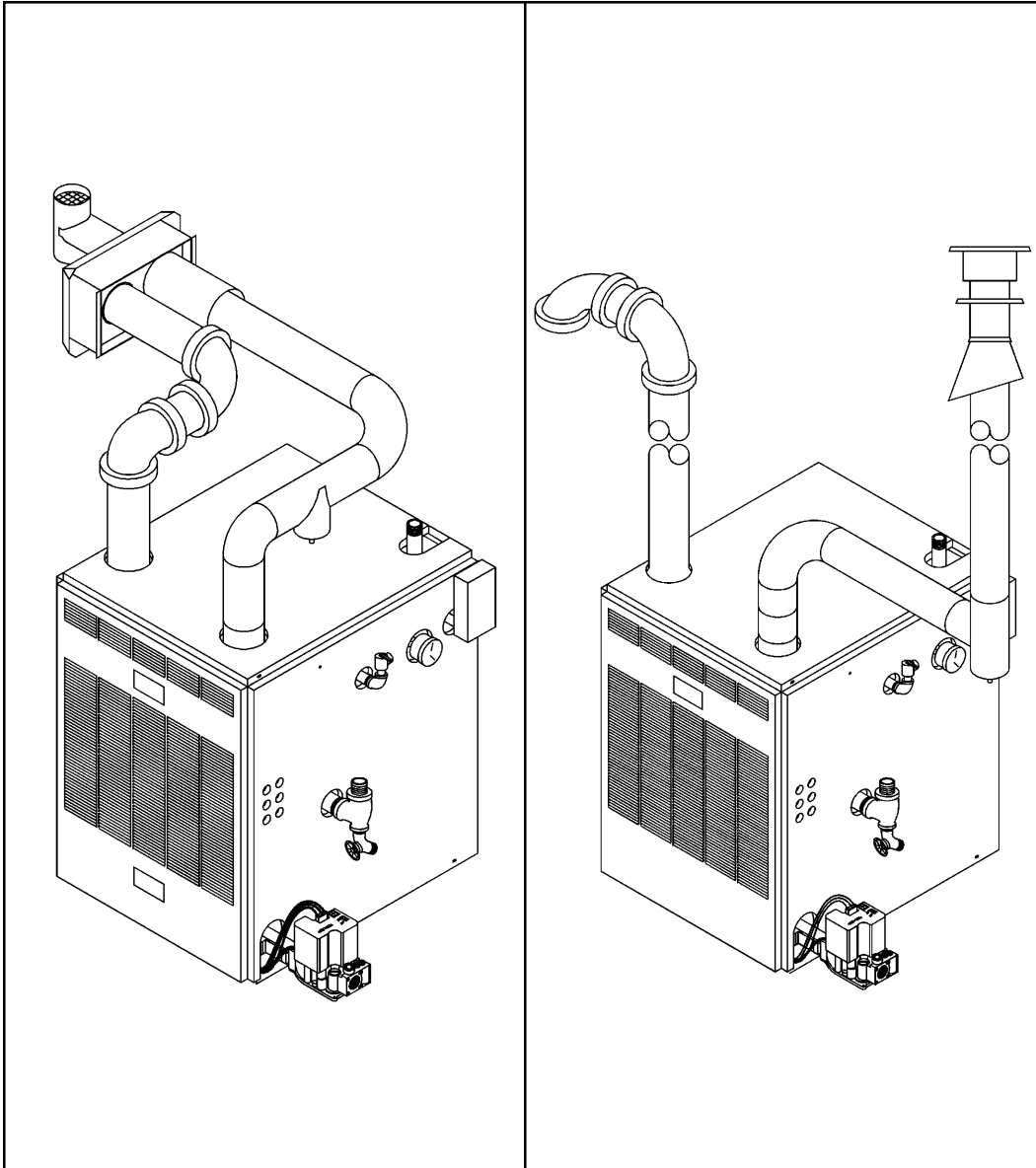

VENTING ADDENDUM



Utica Boilers • P.O. Box 4729 • Utica, NY 13504

**APPLICABLE FEDERAL CODES
UNITED STATES**

NFPA 54/ANSI Z223.1 National Fuel Gas Code (Part 7)
NFPA/ANSI211 Chimneys, Fireplaces, Vents and Solid Fuel Burning Appliances

CANADA

CAN1-B149.1 Installation Codes for Gas-Burning Equipment
B149.2 Installation Codes for Gas-Burning Equipment

These codes contain information on special gas vents for Category II, III and IV appliances, vent sizing, location, air space clearances to combustibles and safe installation practices. The gas vent installer should be familiar with these National or Canadian Codes as well as Local Codes and Regulations.

VENTILATION & COMBUSTION AIR

! WARNING: AIR OPENINGS TO COMBUSTION AREA MUST NOT BE OBSTRUCTED. BY FOLLOWING THE CHART BELOW, ADEQUATE COMBUSTION AIR CAN BE MAINTAINED.

VENTILATION REQUIREMENTS		COMBUSTION AIR REQUIREMENTS
Model No.	Vent Opening Dimensions	Inlet Vent Pipe 3" (8cm)
USC3	5" X 5"	30' With 2 Elbows
	13cm x 13cm	914 cm With 2 Elbows
USC4	8" X 8"	30' With 2 Elbows
	20 cm x 20 cm	914 cm With 2 Elbows
USC5	9" X 9"	20' With 2 Elbows
	23 cm x 23 cm	610 cm With 2 Elbows

For Closet Installation a vent opening must be placed in wall or door directly across from the front of the boiler with a minimum opening as listed above. The vent opening must be located 28" (71.12 cm) up from the floor. (See figure 1 at right.)

Note: If covering the hole with screen or using louvers, the opening must have the same free flowing area as the opening in the wall with no screen or louvers.

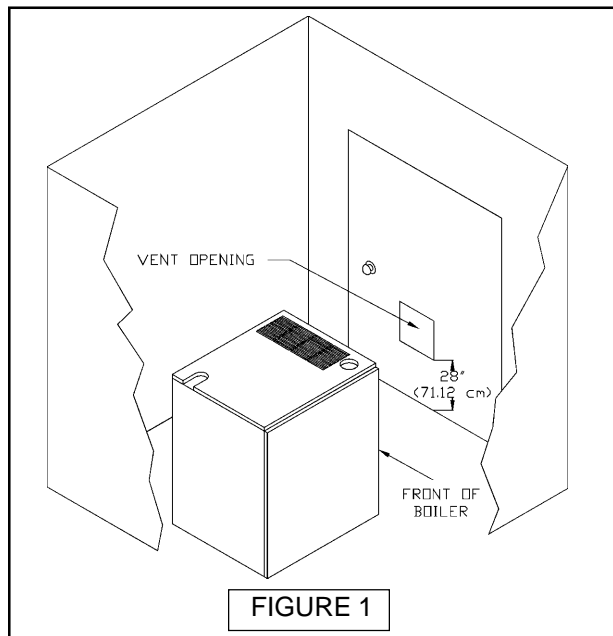

VENT PIPE INSTALLATION INSTRUCTIONS

THIS BOILER IS DESIGN CERTIFIED FOR USE WITH THE FOLLOWING VENTING SYSTEMS.

COMPANY	HEAT-FAB®	FLEX-L®	Z-FLEX®	ProTech®
PRODUCT	SAF-T-VENT™	STAR-34™	Z-VENT™	FasNSeal™

! CAUTION: THE ABOVE VENT PIPE AND FITTINGS ARE USED FOR VENTING GAS BURNING CATEGORY III, IV, AND DIRECT VENT APPLIANCES. DO NOT USE THIS VENT PIPE OR FITTINGS FOR VENTING APPLIANCES BURNING FUELS SUCH AS WOOD, OIL, KEROSENE OR COAL.

! CAUTION: DO NOT USE THIS VENT PIPE AND FITTINGS FOR VENTING INCINERATORS OF ANY KIND.

! WARNINGS:

1. FOR CORRECT INSTALLATION OF VENT SYSTEM, READ ALL OF THESE INSTRUCTIONS.
2. FAILURE TO USE THIS VENTING SYSTEM WILL VOID THE MANUFACTURER'S WARRANTY AND MAY RESULT IN RAPID DETERIORATION OF THE VENTING SYSTEM, A POTENTIAL HEALTH HAZARD.
3. FAULTY VENT INSTALLATION CAN ALLOW TOXIC FUMES TO BE RELEASED INTO LIVING AREAS. THIS MAY CAUSE SERIOUS BODILY INJURY OR PROPERTY DAMAGE. VENT PERFORMANCE MAY ALSO BE AFFECTED BY IMPROPER ASSEMBLY.
4. INSTALL SEPARATE VENTS FOR FORCED EXHAUST APPLIANCES AND NATURAL DRAFT APPLIANCES. A COMMON VENT BETWEEN NATURAL DRAFT AND FORCED EXHAUST APPLIANCES MAY CAUSE TOXIC GASES TO EXHAUST THROUGH THE NATURAL DRAFT APPLIANCE RATHER THAN TO OUTSIDE AIR. BREATHING EXHAUST GASES WILL CAUSE SERIOUS PERSONAL INJURY OR DEATH.

! WARNING: ALL INSTALLATIONS OF BOILERS AND VENTING SHOULD BE DONE ONLY BY A QUALIFIED EXPERT AND IN ACCORDANCE WITH THE APPROPRIATE UTICA BOILERS, INC. MANUAL. INSTALLING OR VENTING A BOILER OR ANY OTHER GAS APPLIANCE WITH IMPROPER METHODS OR MATERIALS MAY RESULT IN SERIOUS INJURY OR DEATH DUE TO FIRE OR TO ASPHYXIATION FROM POISONOUS GASES SUCH AS CARBON MONOXIDE WHICH IS ODORLESS AND INVISIBLE.

HORIZONTAL VENT PIPING TYPICAL INSTALLATION

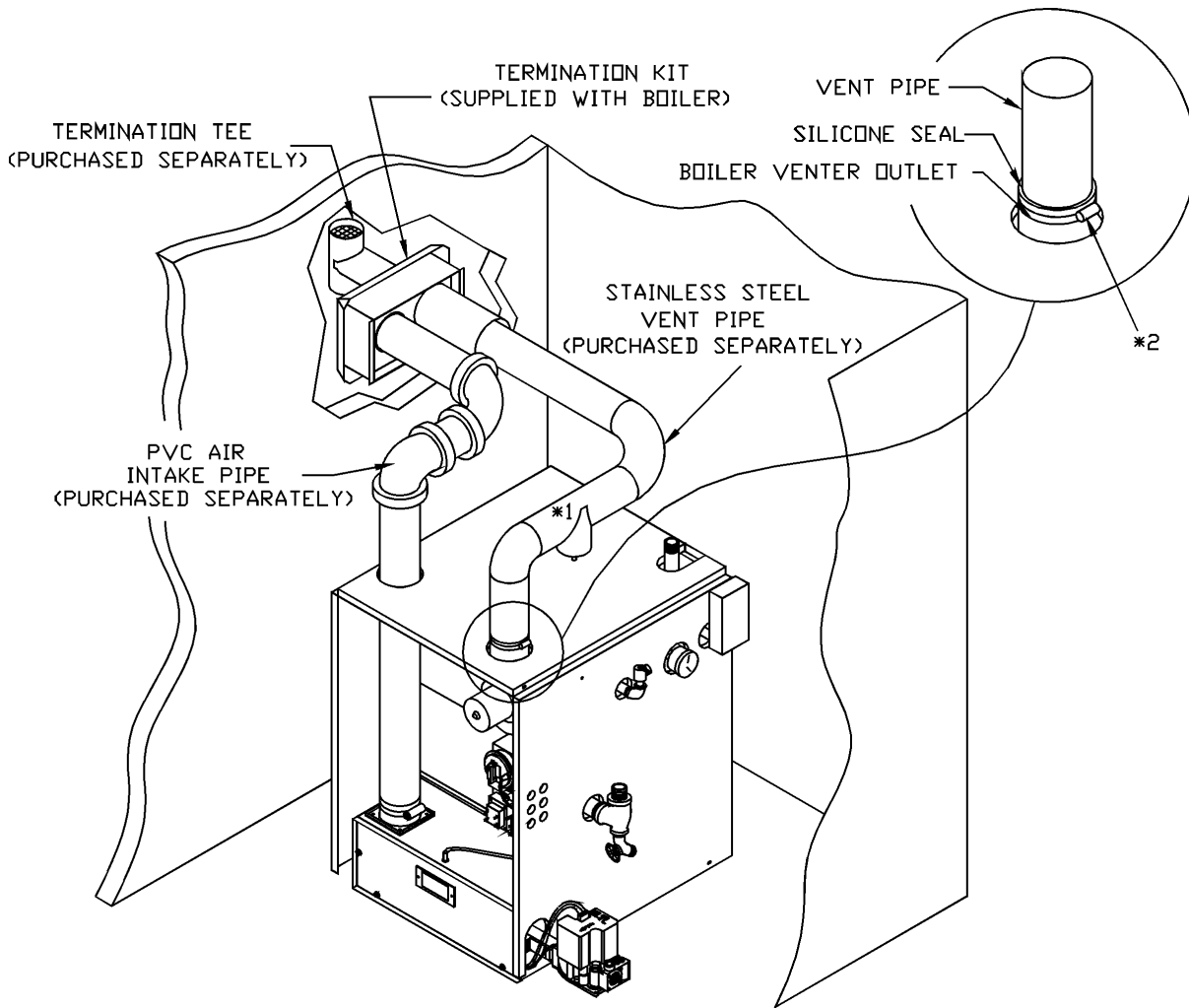

Notes:

***1 : A condensate tee/drain is only needed when horizontal vent lengths exceed 10 feet.**

***2 : Insert vent pipe in boiler vent outlet (vent adapter), apply silicone completely around edge of outlet and tighten clamp.**

FIGURE 2

HORIZONTAL VENT PIPE LENGTHS

MODEL	VENT PIPE DIAMETER	VENT LENGTHS *		INLET PIPE
		Maximum	Minimum	
USC3	3" (8 cm)	30' (914 cm) With Condensate Tee & 2 Elbows	2' (61 cm) With 1 Elbow	30' (914 cm) with 2 Elbows
USC4	3" (8 cm)	30' (914 cm) With Condensate Tee & 2 Elbows	2' (61 cm) With 1 Elbow	30' (914 cm) With 2 Elbows
USC5	3" (8 cm)	20' (610 cm) With Condensate Tee & 2 Elbows	2' (61 cm) With 1 Elbow	20' (610 cm) With 2 Elbows

Example: 20 feet (610 cm) of vent pipe with 1 elbow is Equivalent to 15 feet (457 cm) of vent pipe with 2 elbows.

* Note: A condensate trap is only required on USC models with over 10' (305 cm) of horizontally run vent piping.

 WARNING: DO NOT INSULATE OR OTHERWISE WRAP VENT PIPE OR FITTINGS. FOLLOW THE VENT PIPE MANUFACTURERS INSTALLATION INSTRUCTIONS FOR HORIZONTAL VENTING.

INSTALLATION PROCEDURE FOR VENTING SYSTEM THROUGH A WALL

1. THE VENT TERMINATION MUST BE LOCATED:

(Refer to figure 9 on page 8 when determining the location of the vent outlet.)

 - A. At least 12 inches (31 cm) above finished grade, or at least 12 inches (31 cm) above the normally expected snow accumulation level in geographical areas where snow accumulates.
 - B. With a vent termination clearance of at least 12 inches (31 cm) from any air openings into a building.
 - C. At least 3 feet (92 cm) above any forced air inlet located within 10 feet (305 cm).
 - D. At least 12 inches (31 cm) horizontally from electric meters, gas meters, regulators and relief equipment.
 - E. For horizontal runs; keep a minimum air space clearance from any combustible material, electric wires, and building insulation of 2 inches (5 cm) for 3" (7.6 cm) vent pipe.
 - F. Do not terminate vent over public walkways or over an area where condensate or vapor could be detrimental to regulators, relief valves, or other equipment.
 - G. Do not locate the vent termination too close to shrubbery as flue products may stunt growth or kill them.
 - I. Some building materials may be affected by flue products expelled near unprotected surfaces. Sealing or shielding of exposed surfaces with a corrosion resistant material (such as aluminum sheet) may be required to prevent staining or deterioration.

- J. When installing vent cap secure it to a noncombustible wall or a combustible wall thimble. Fasten vent cap and seal passage as shown in figures 3, below, and 5a and 5b on page 6.
 - K. See the National or Canadian Codes listed at the beginning of these instructions for additional information on termination location.
2. Using the template provided as a guide, cut a hole through the wall. Then secure the template to the inside of the wall over the hole. (See figures 5a and 5b on page 6.)
NOTE: If installing through a non combustible wall make (2) 3.1/2" holes on center through the wall. (approximately 5.1/4" apart on center)
 3. For venting through a non-combustible wall, remove the vent termination thimble plate assembly from the termination assembly. (See figures 5a and 5b on page 6.)
 4. Install the vent termination assembly through the opening and secure it to the outside wall.
 5. Install the PVC pipe from the vent termination assembly to the boilers air inlet.
 6. Assemble and install the vent pipe according to the vent pipe manufacturers instructions.
 7. Install the vent pipe through the termination assembly and extend it 3" (8 cm) beyond the termination assembly. (See figures 5a and 5b on page 6.)
 8. Install the termination wind deflector with the four (4) screws provided. (See figures 5a and 5b on page 6.)
 9. Install the draw collar around the pipe and tighten the nut and bolt until tightly secured. (See figures 5a and 5b on page 6.)
 10. Secure the termination tee according to the vent pipe manufacturers instructions.

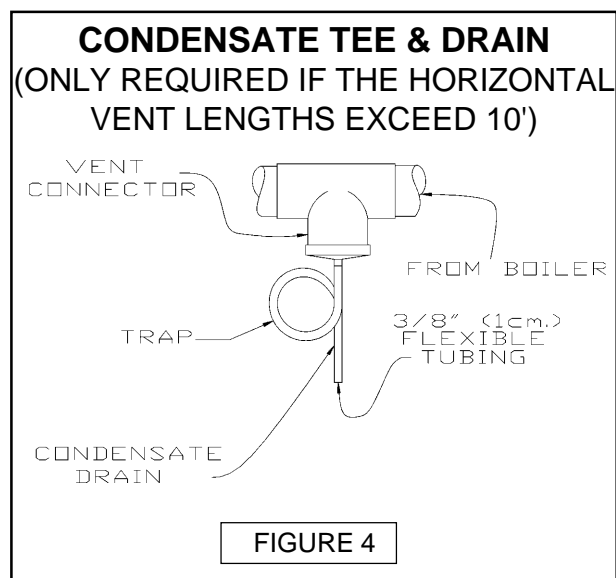
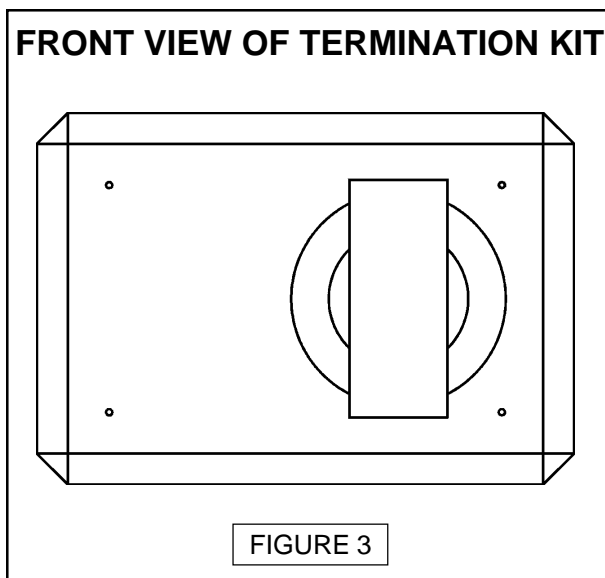

**TOP VIEW OF TERMINATION KIT AND WALL
(FOR COMBUSTIBLE WALL INSTALLATION)**

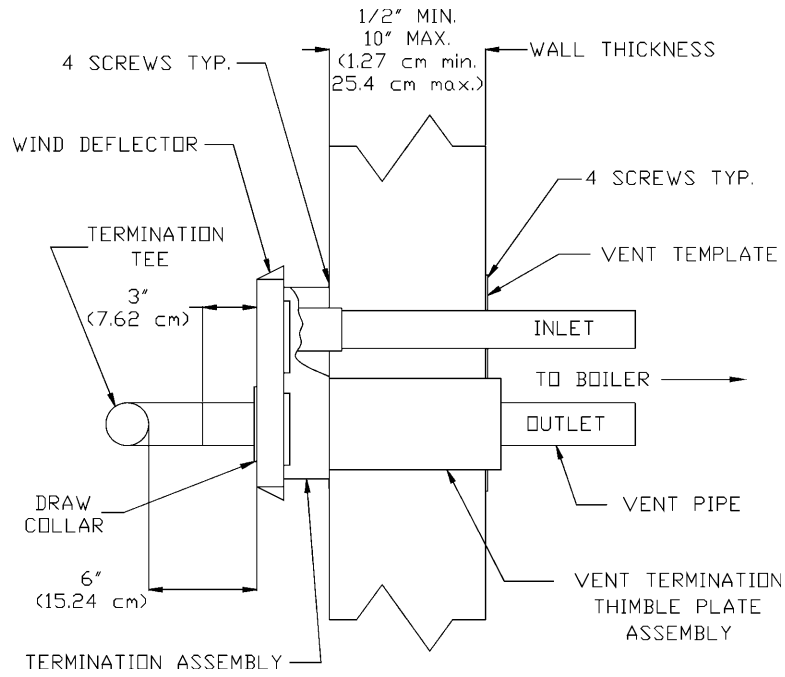

FIGURE 5a

**TOP VIEW OF TERMINATION KIT AND WALL
(FOR NON-COMBUSTIBLE WALL INSTALLATION
REMOVE THIMBLE WALL PLATE ASSEMBLY)**

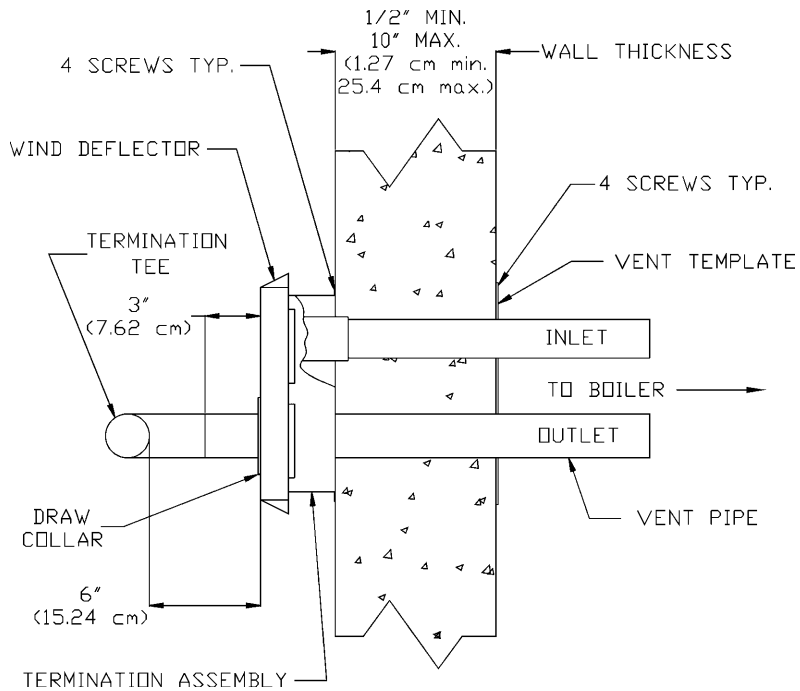
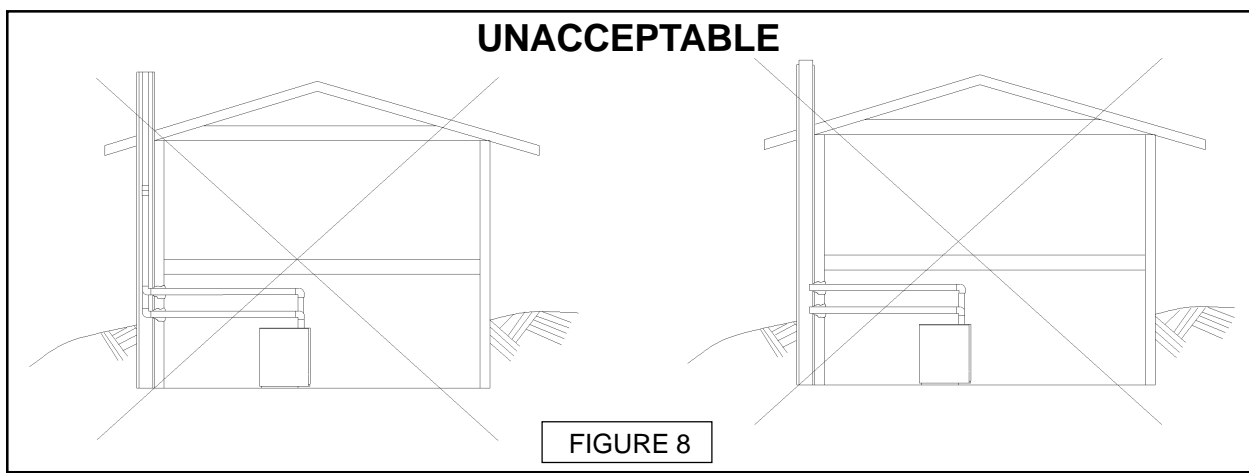
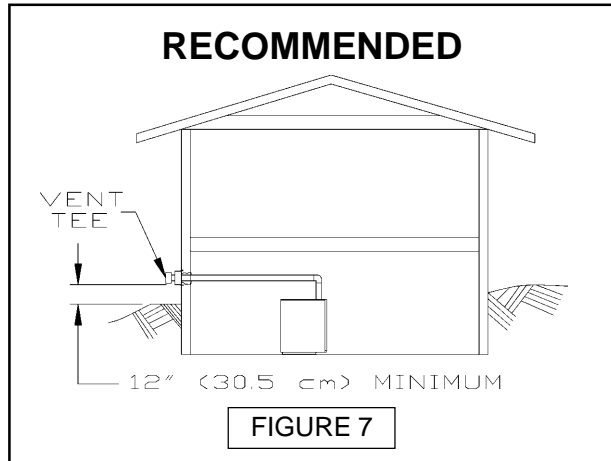
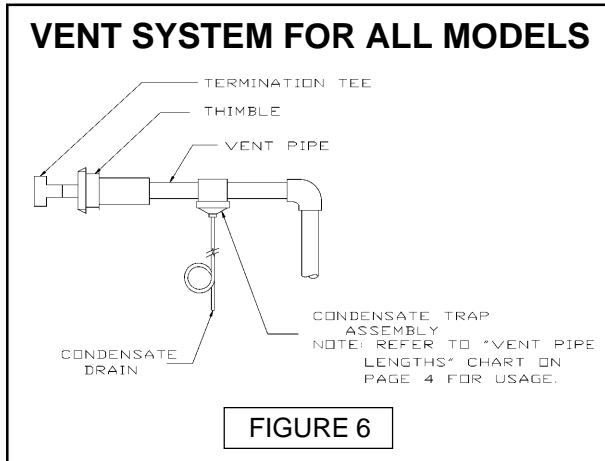

FIGURE 5b

For vent pipe installation refer to the vent pipe manufacturers instructions.



CONDENSATE DRAINS

(Only needed when horizontal vent lengths exceed 10 feet)

! WARNING: DO NOT PLACE CONDENSATE DRAIN WHERE FREEZING MAY OCCUR.

CONDENSATE DRAINS ARE REQUIRED IN THE VENT WHEN USING THE CONDENSATE TEE. THE CONDENSATE DRAIN FITTING MUST BE PLUMBED TO A SANITARY DRAIN FOR LIQUID CONDENSATE DISPOSAL.

Condensate drain is plumbed with 3/8" (1 cm) inside diameter flexible tubing. (See Figure 4 on page 5.) Refer to "GENERAL INSTRUCTION FOR SEASONAL STARTUP AND MAINTENANCE", in the Installation Manual for maintenance recommendations and schedule.

1. **Flexible Tubing Condensate Drain.** In the vent, and close to the appliance, install a tee with a run outlet. Install condensate drain in the down outlet with high temperature adhesive. (See Figure 4 on page 5.) Connect the condensate drain outlet to commercially available flexible tubing (minimum length 40" (102 cm)). Below the drain outlet, make a 6" (15.2 cm) diameter loop in 3/8" (1 cm) ID tubing, or a 9" (22.9 cm) diameter loop in 5/8" (1.6 cm) ID tubing. Secure the loop with a plastic cable tie. Run the other end of the flexible tubing to a sanitary drain (Use a condensate pump if necessary). Fill loop with water before firing the boiler.

NOTE: IF THERE IS A POTENTIAL FOR EXCESSIVE WINDS, SPECIAL CONSIDERATION SHOULD BE GIVEN TO LOCATE THE VENT TERMINATION AWAY FROM THE WINDWARD SIDE OF THE BUILDING.

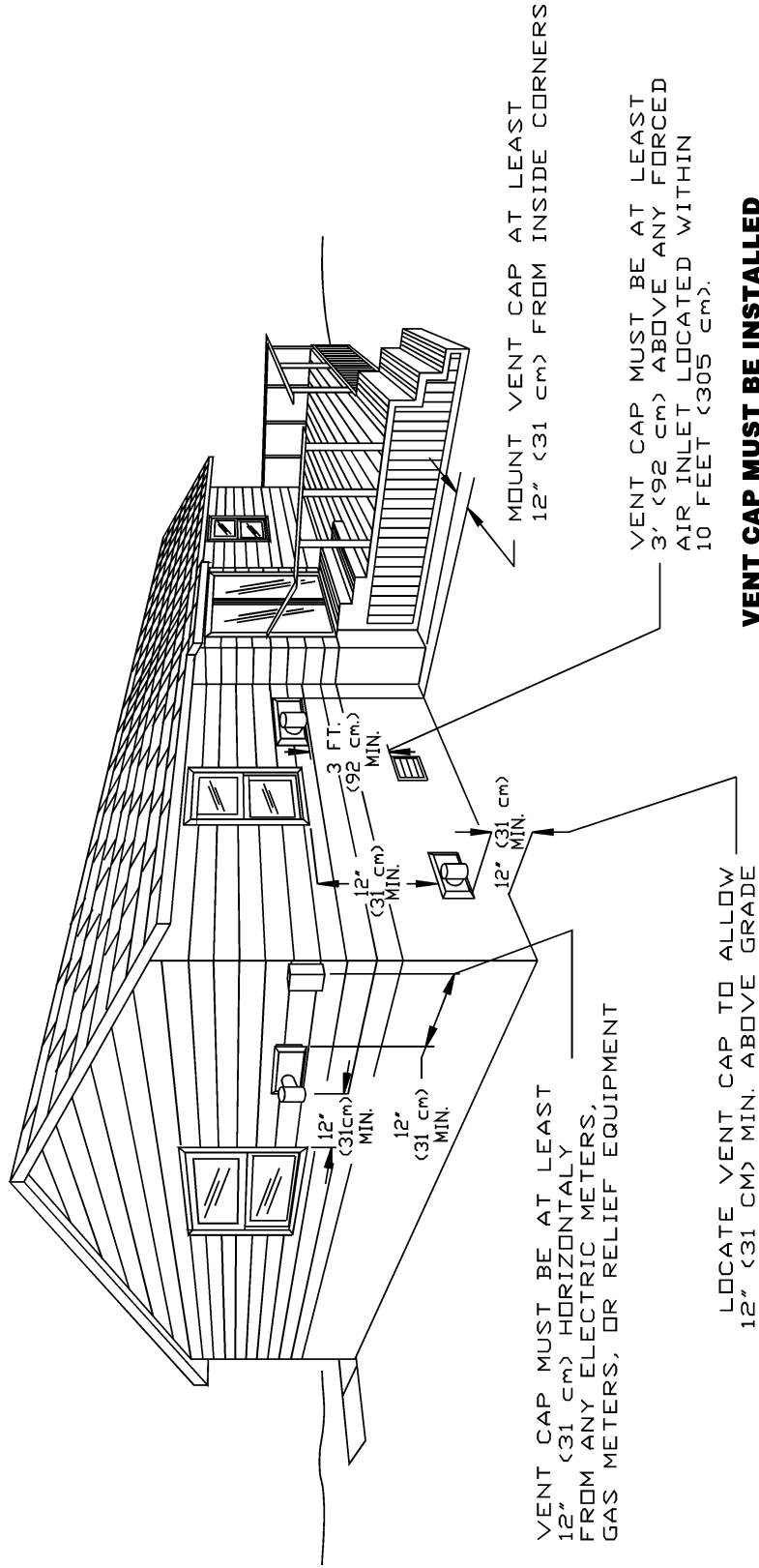

VENT CAP MUST BE INSTALLED WITH A VENT TERMINATION CLEARANCE OF AT LEAST 12 INCHES (31 cm) FROM ANY AIR OPENING INTO A BUILDING

FIGURE 9

Flex-L® Star-34™ Vent Pipe Components

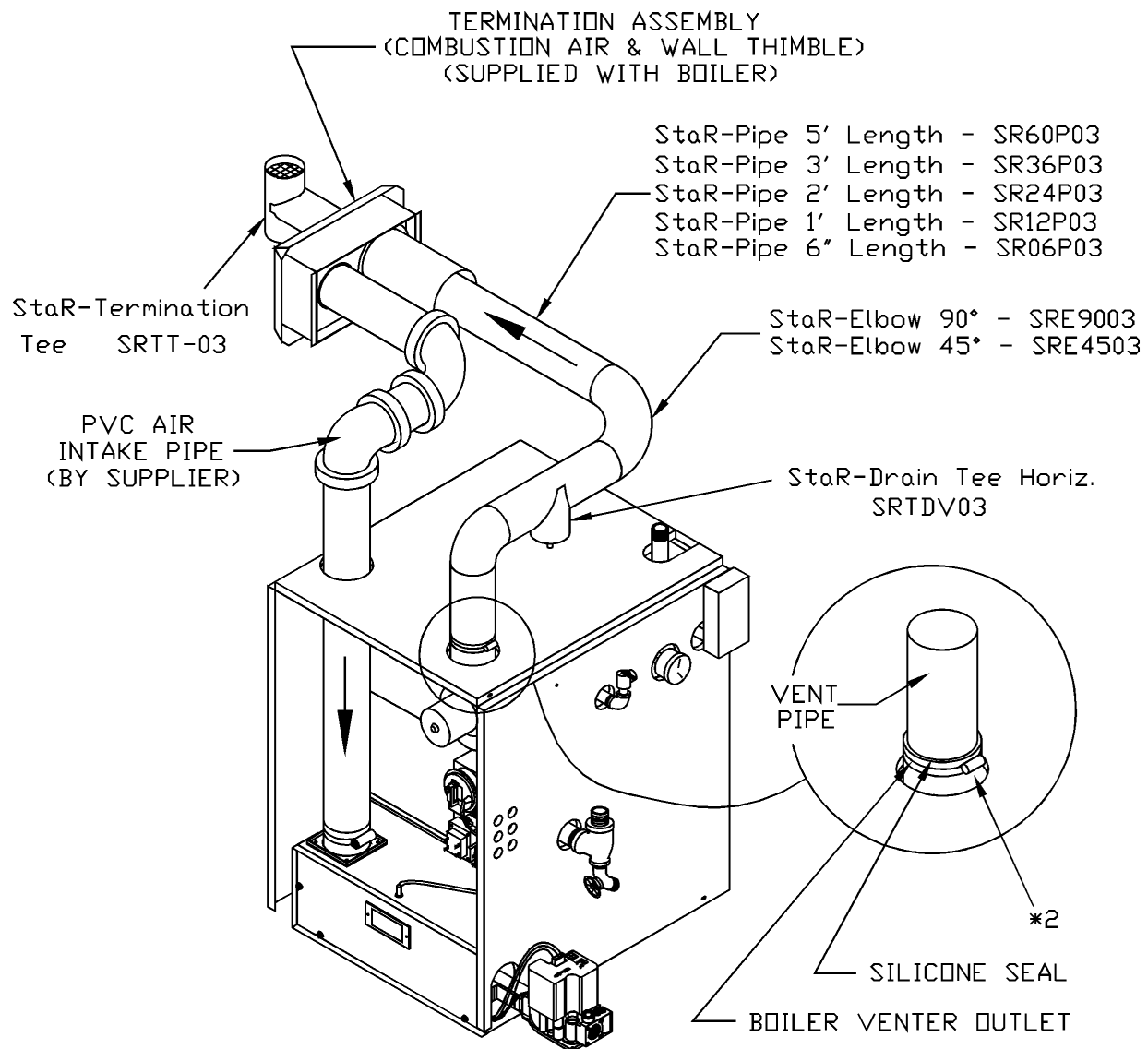

Notes:

***1 : A condensate tee/drain is only needed when horizontal vent lengths exceed 10 feet.**

***2 : Insert vent pipe in boiler venter outlet (vent adapter), apply silicone completely around edge of outlet and tighten clamp.**

FIGURE 10

PAGE 9

Heat Fab® Saf-T Vent™ Vent Pipe Components

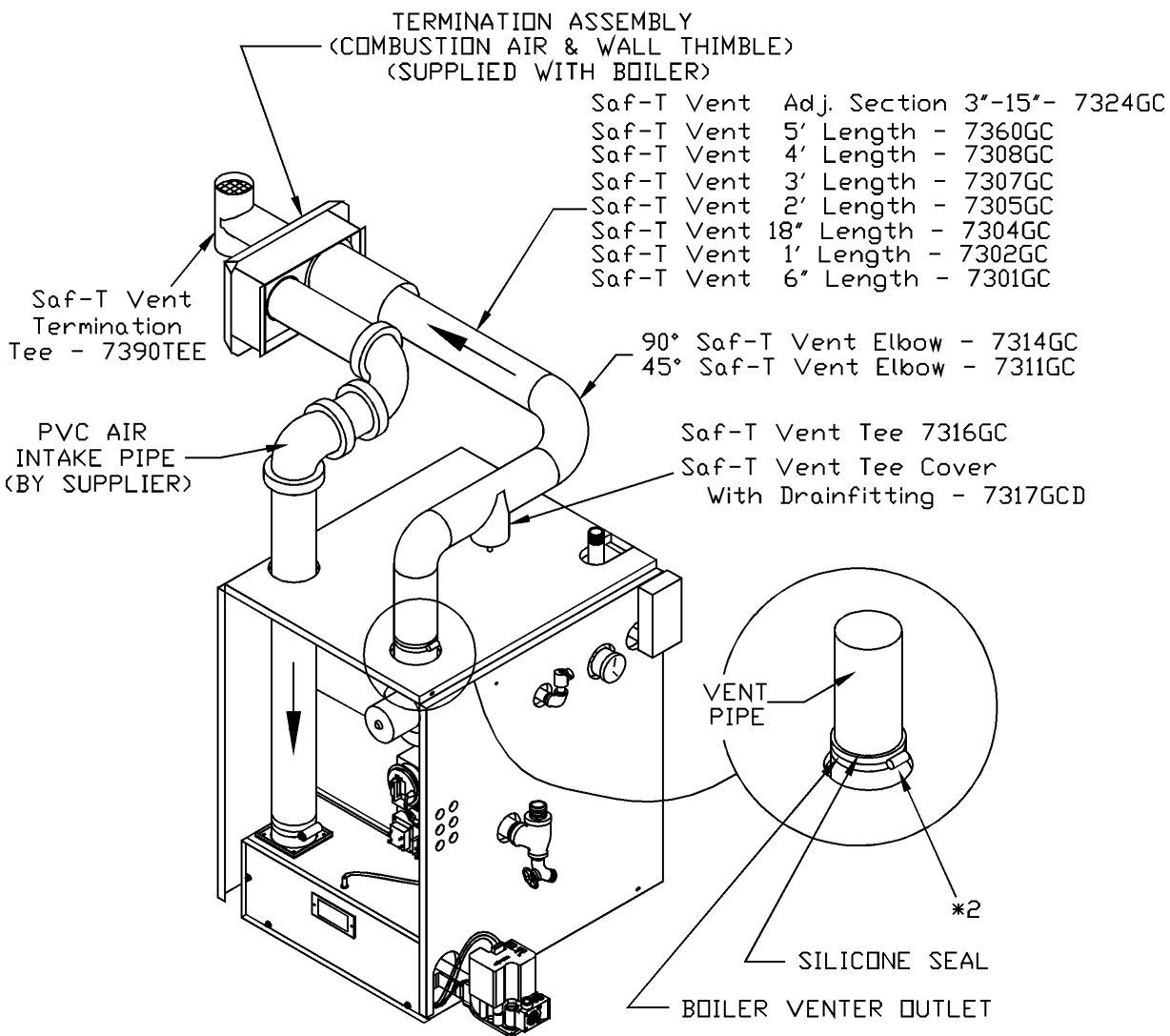

Notes:

***1 : A condensate tee/drain is only needed when horizontal vent lengths exceed 10 feet.**

***2 : Insert vent pipe in boiler venter outlet (vent adapter), apply silicone completely around edge of outlet and tighten clamp.**

FIGURE 11

Z-Flex® Z-vent™ Vent Pipe Components

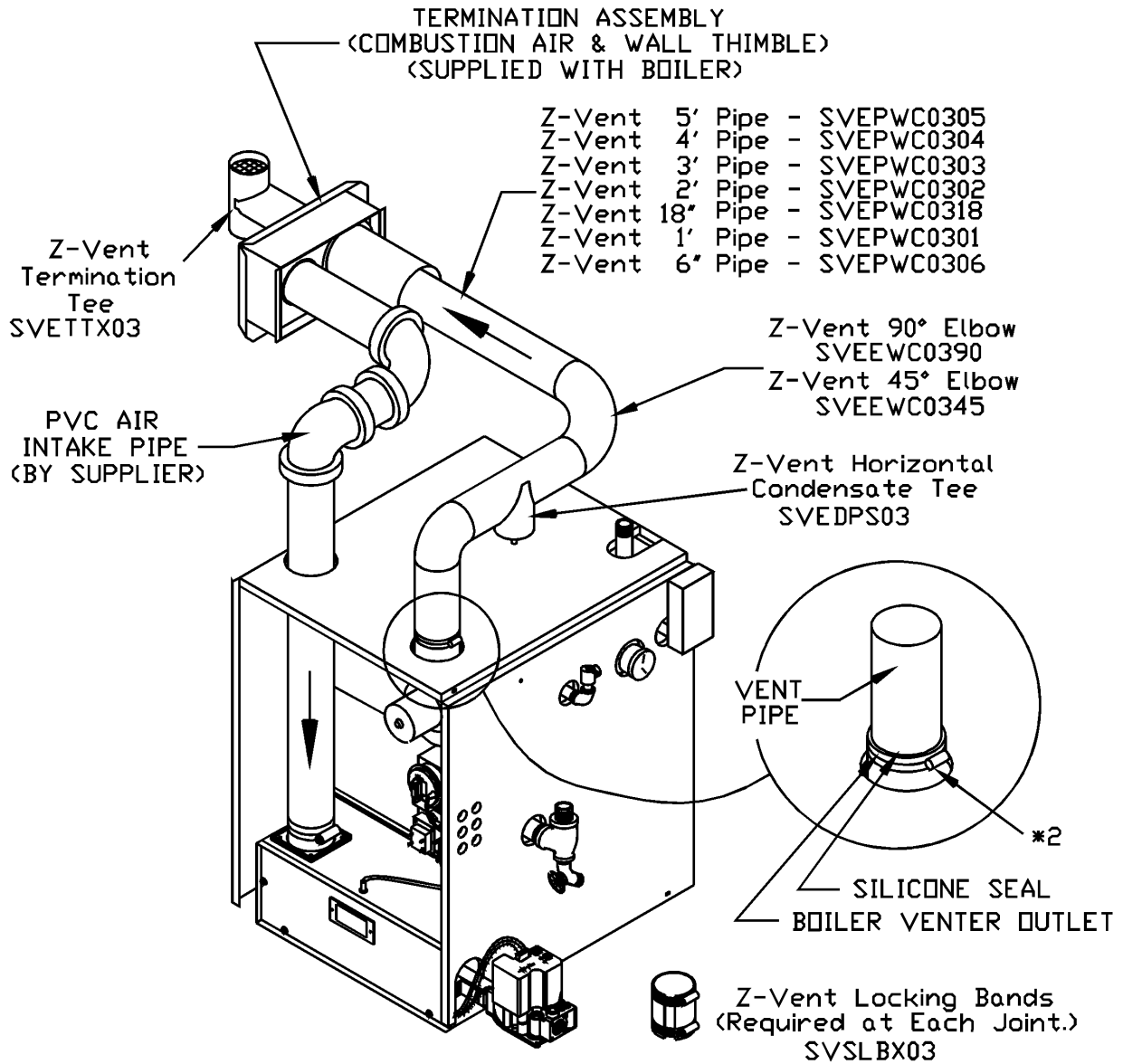

Notes:

***1 :** A condensate tee/drain is only needed when horizontal vent lengths exceed 10 feet.

***2 :** Insert vent pipe in boiler venter outlet (vent adapter), apply silicone completely around edge of outlet and tighten clamp.

FIGURE 12

ProTech® FasNSeal™ Vent Pipe Components

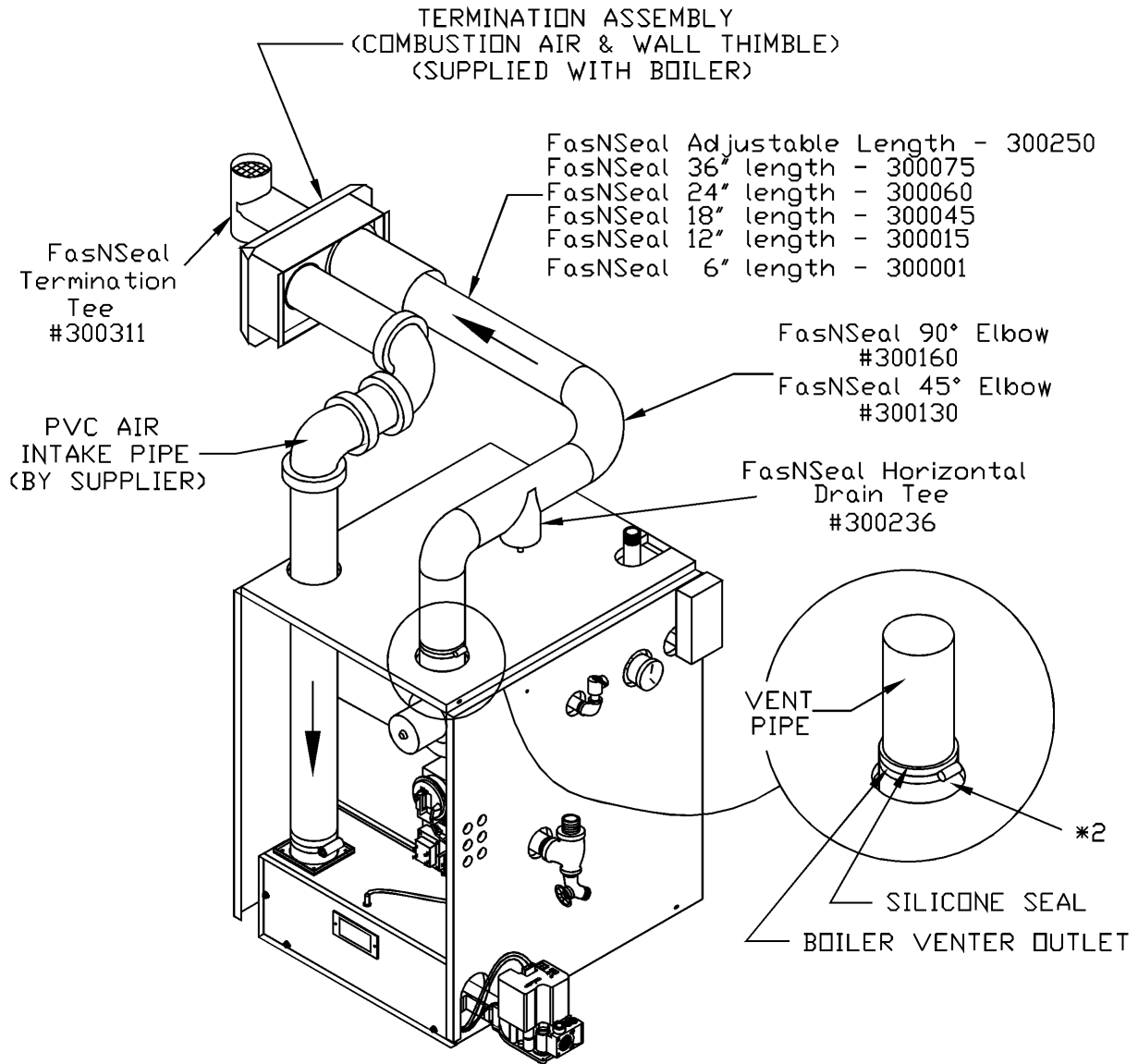

Notes:

- *1 : A condensate tee/drain is only needed when horizontal vent lengths exceed 10 feet.**
- *2 : Insert vent pipe in boiler venter outlet (vent adapter), apply silicone completely around edge of outlet and tighten clamp.**

FIGURE 13

VERTICAL VENT PIPING TYPICAL INSTALLATION

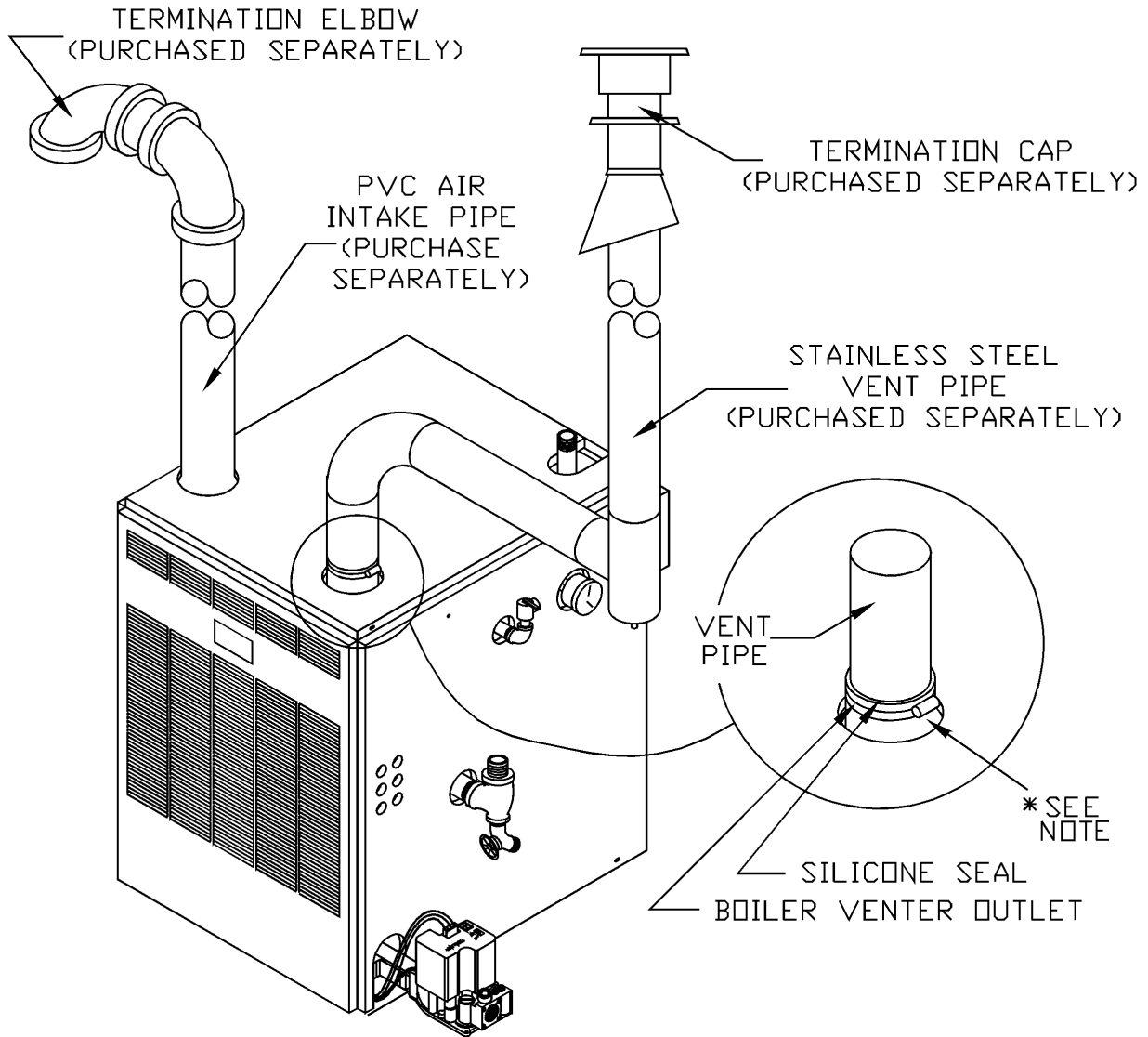

Notes:

- * Insert vent pipe in boiler venter outlet (vent adapter), apply silicone completely around edge of outlet and tighten clamp.

INSTALLATION PROCEDURE FOR VERTICAL VENTING

⚠ WARNING: DO NOT INSULATE OR OTHERWISE WRAP VENT PIPE OR FITTINGS. FOLLOW THE VENT PIPE MANUFACTURERS INSTALLATION INSTRUCTIONS FOR VERTICAL VENTING.

1. The Vent Termination Must Be Located:
 - A. With a 2" clearance to combustibles materials.
 - B. 4 feet minimum above the ridge (see fig. 17).
 - C. Vent air intake must be 2' below vent outlet and facing away from the exhaust outlet (see fig. 17,18).
 - D. Use vent pipe manufacturer's vent cap, fire stop, support collar, roof flashing, and storm collar.
 - E. Install a vertical vent drain tee (see fig. 15). Also see pg. 7 for installation of condensate drain.
 - F. Fill the 3/8 flexible tubing with water before firing the boiler.
2. Configuration of vent air intake (see fig. 16).

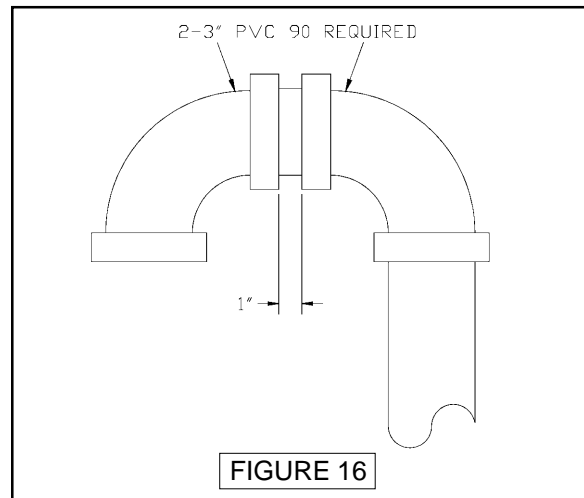
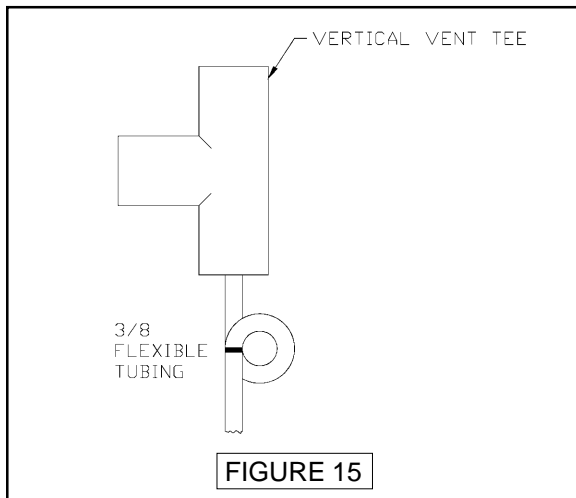

VENT PIPE LENGTHS

MODEL	VENT PIPE DIAMETER	VENT LENGTHS *		INLET PIPE
		Maximum	Minimum	
USC3 USC4 USC5	3" (8cm)	30' (914cm) with 1-Vertical Drain Tee 1-90° Elbow, and 1-Termination Cap *5' (23.6cm) Max. Horizontal	2' (9.5cm)	30' (914cm) maximum 2' (9.5cm) Minimum 4-90° Elbow (Including Intake 90° Elbow on Roof.)

BOILER INSTALLATION MUST USE 90° ELBOW OFF BOILER FOR HORIZONTAL RUN TO THE VERTICAL DRAIN TEE.

* MUST FACE AWAY FROM EXHAUST OUTLET.

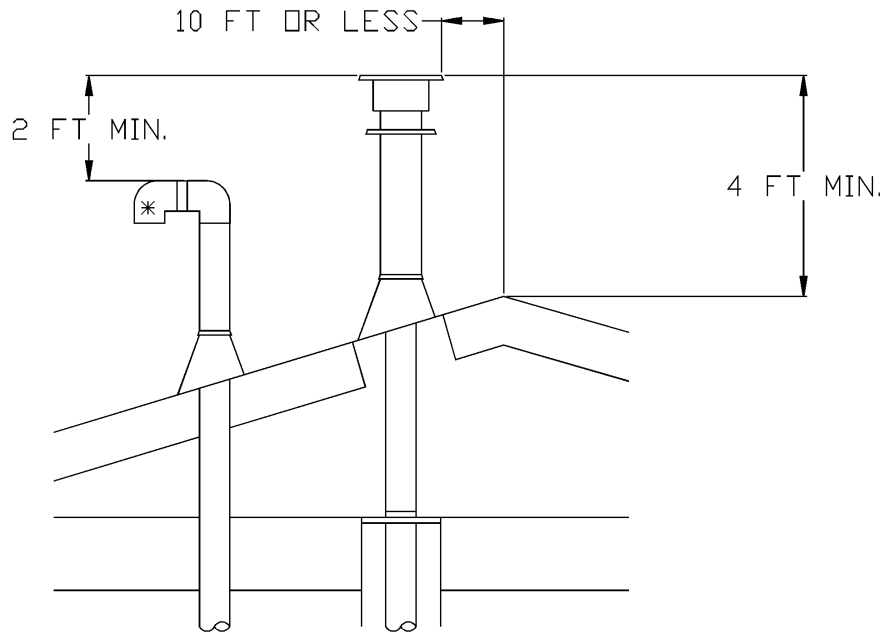

TERMINATION 10' OR LESS FROM RIDGE

FIGURE 17

* MUST FACE AWAY FROM EXHAUST OUTLET.

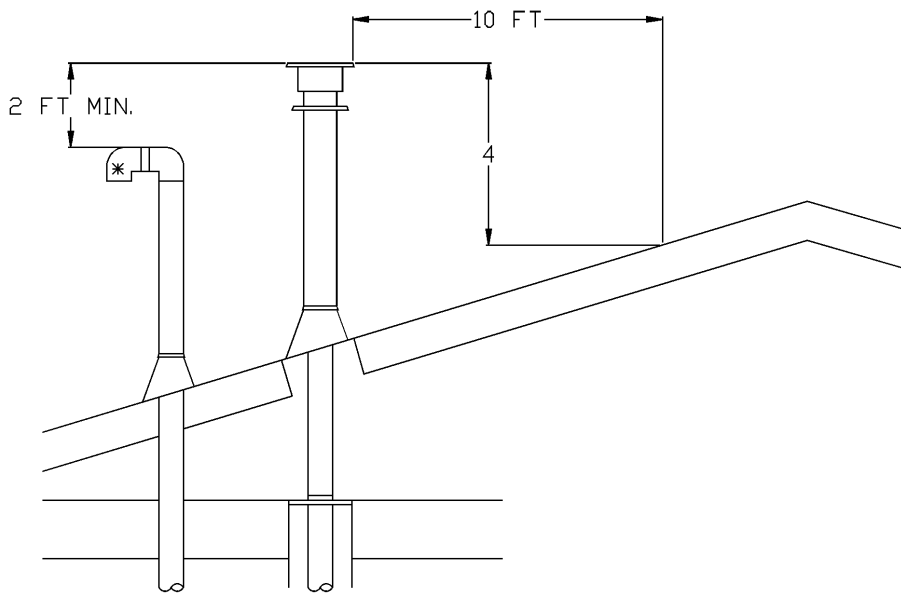

TERMINATION MORE THAN 10' FROM RIDGE

FIGURE 18

Flex-L® Star-34™ Vent Pipe Components

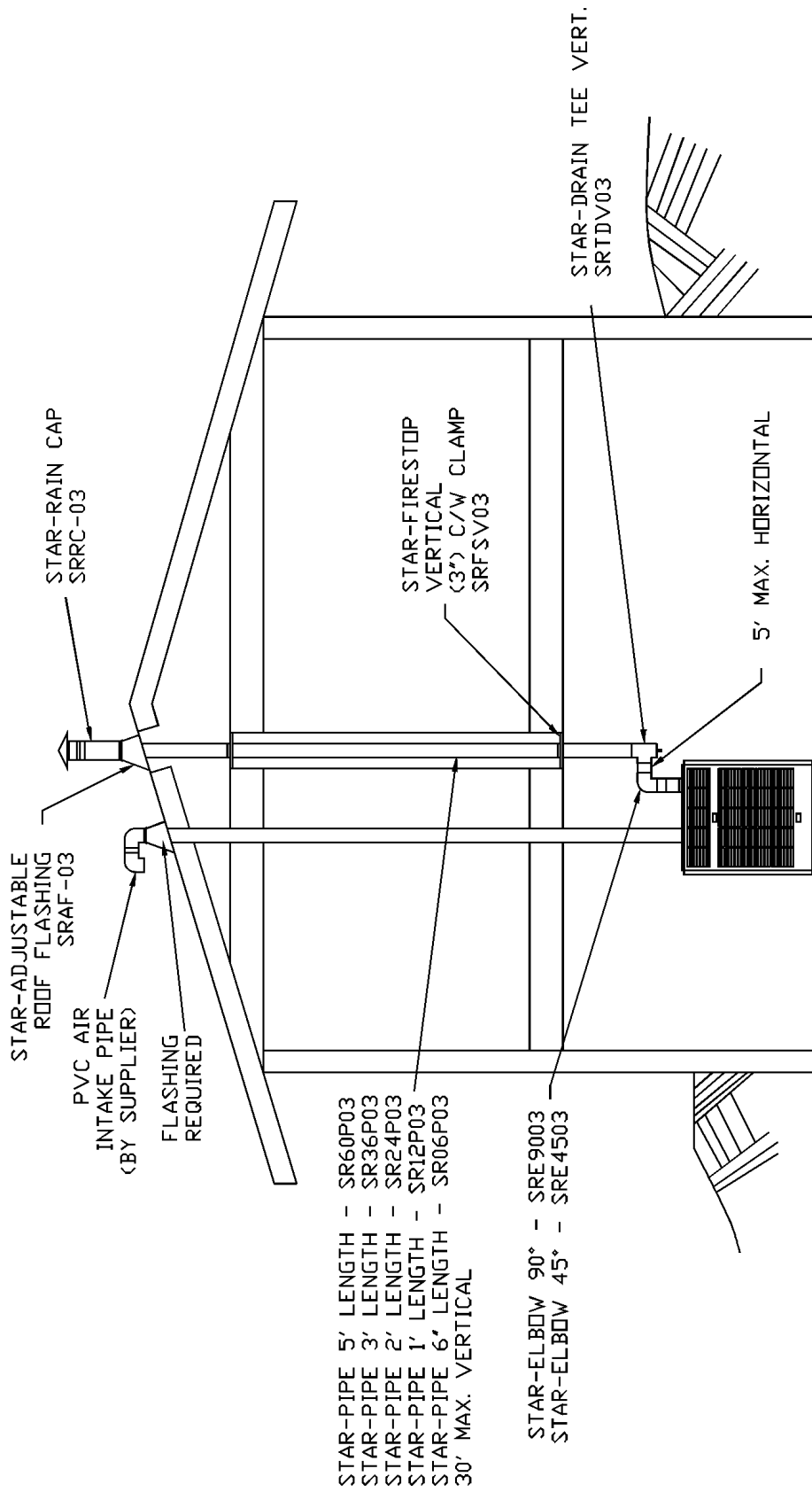

FIGURE 19

Z-Flex® Z-vent™ Vent Pipe Components

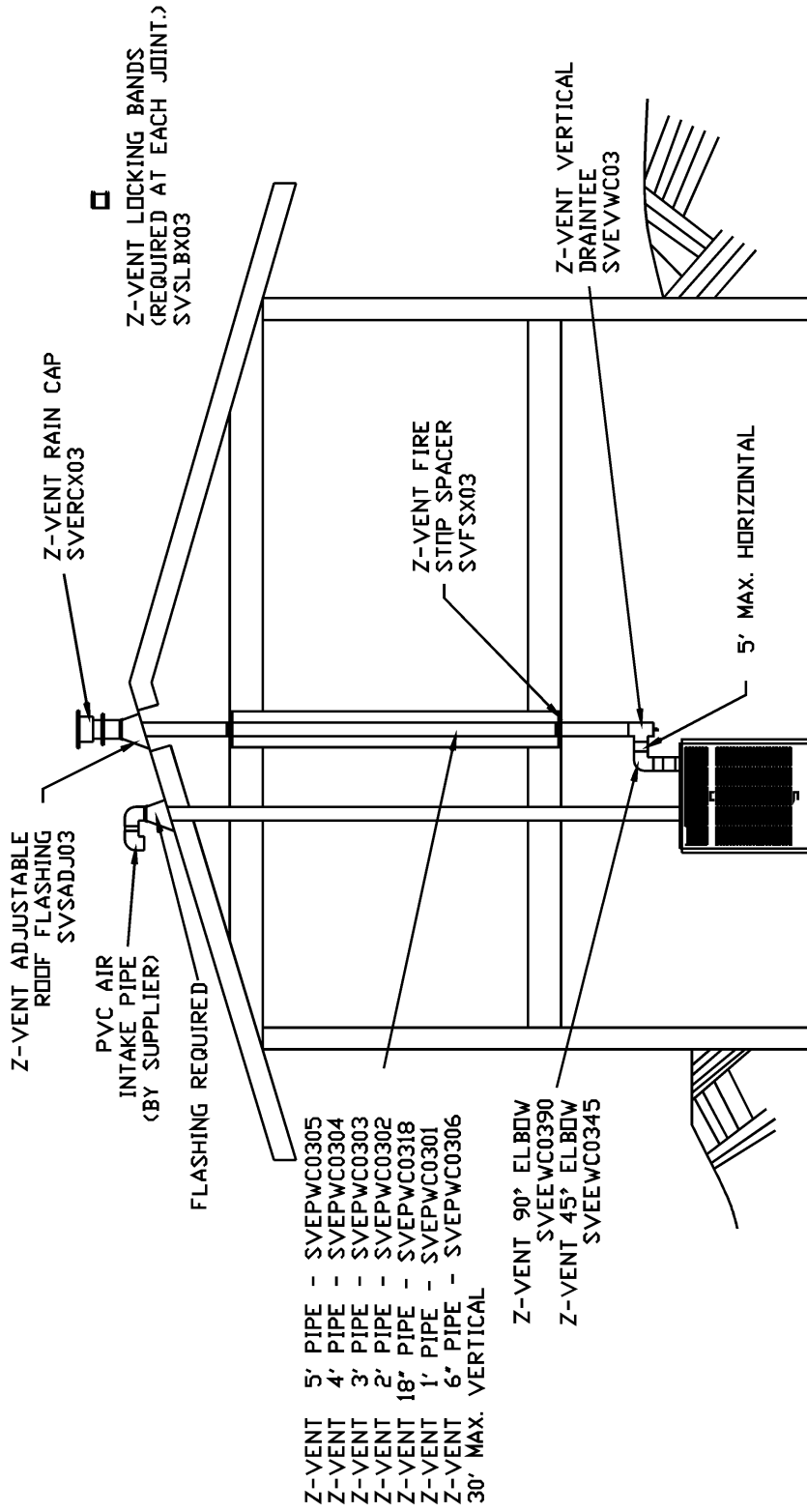

FIGURE 20

Heat Fab® Saf-T Vent™ Vent Pipe Components

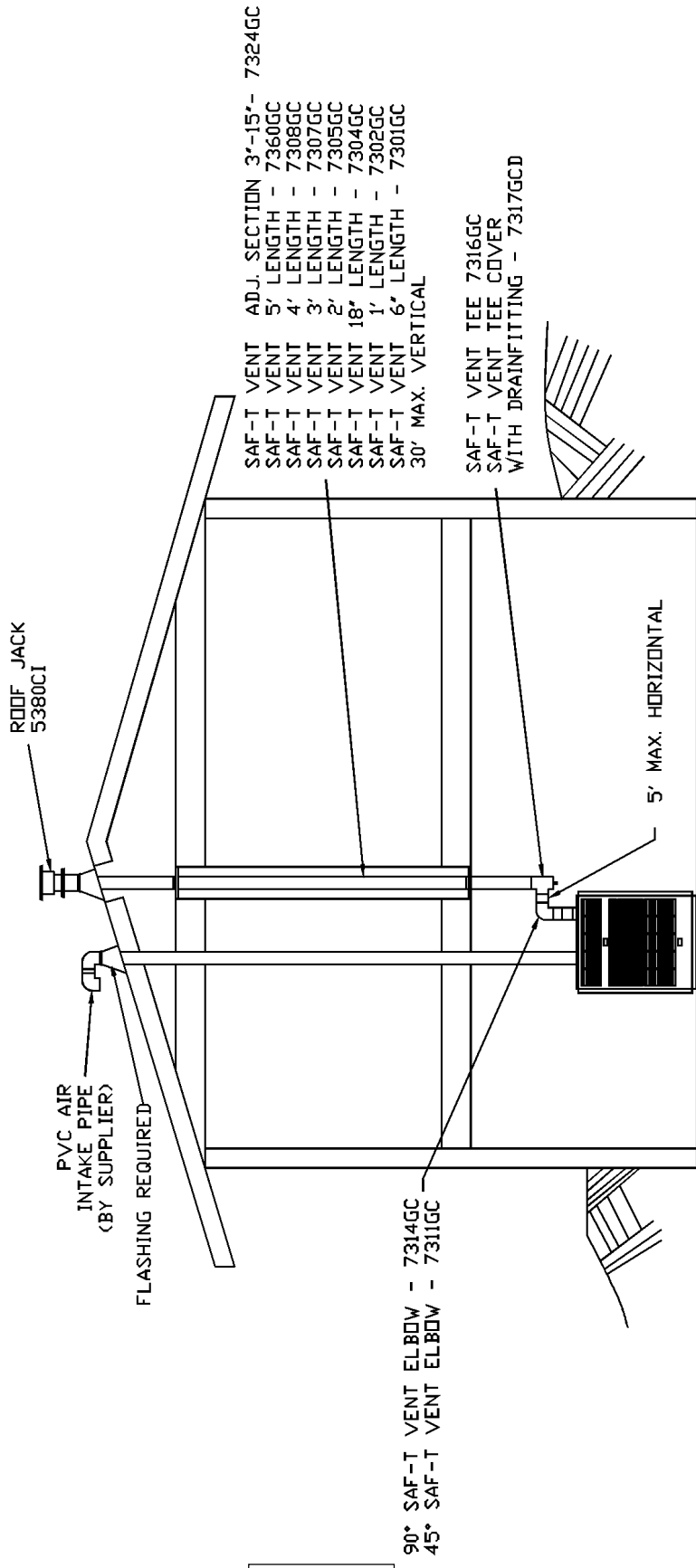

FIGURE 21

ProTech® FasNSeal™ Vent Pipe Components

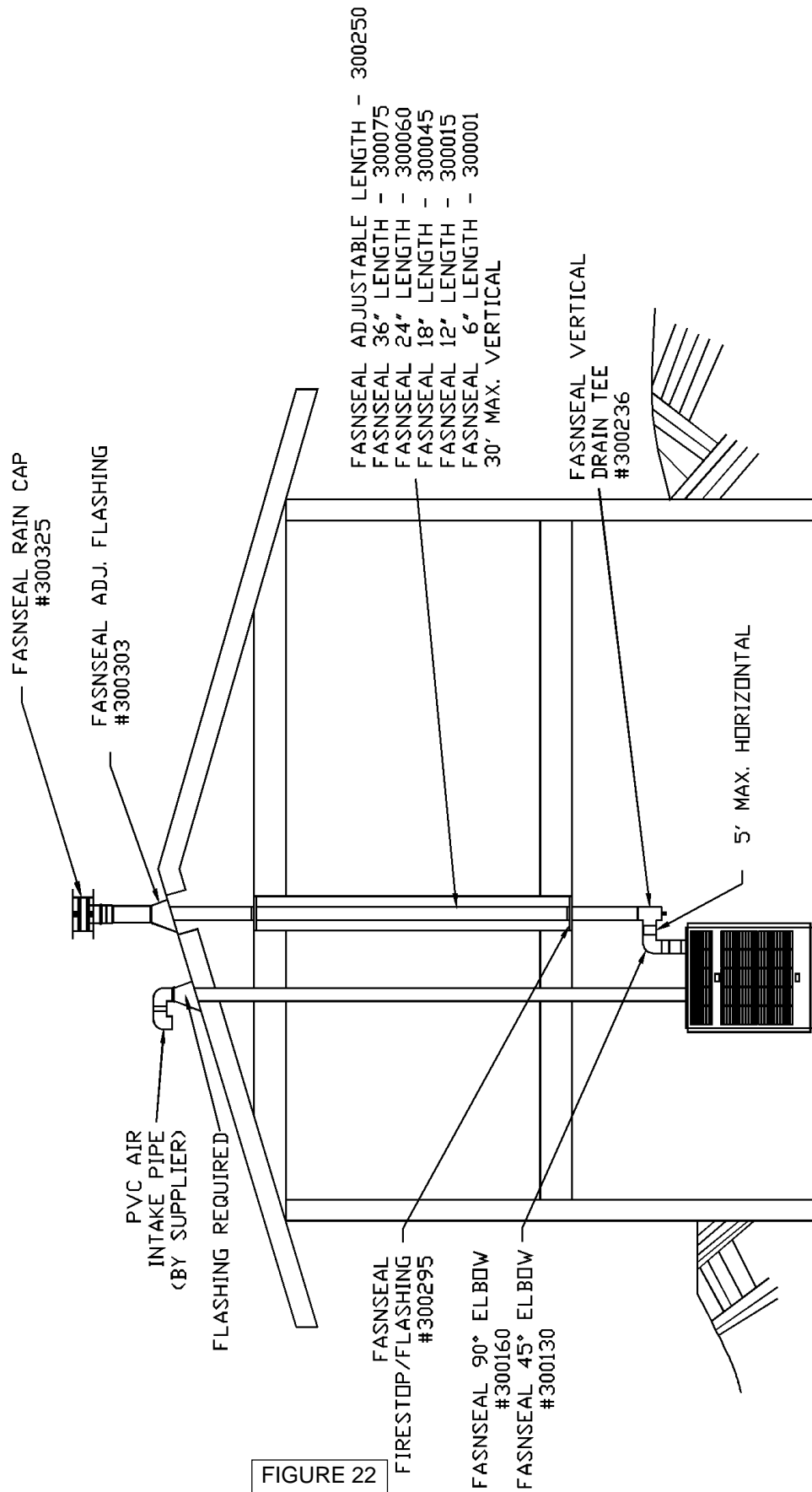

FIGURE 22