



Introducing.... the **DWB Boiler**

1-model COMBI Boiler for CH and DHW Production

2-models Heating only





DWB-CHB150 Combi

DWB-CHB100/ DWB-CHB130 Heating Only

Features-All Models

- Efficiency 85% AFUE-Energy Star
- Inducer Fan and Gas Valve modulate for operation between 33% & 100% of capacity
- Chimney (Category I) or Horizontal vent (Category III)
- Advanced Controls- Digital Display with temperature indication diagnostics and status symbols
- Copper Heat Exchanger with Built in Pressure Activated Bypass Piping
- Wall Mounted Boiler
- Diverting valve
- Natural Gas – Optional LP Field Conversion Kit available

Features CCB-150



- CH and DHW production
- DHW -Domestic Hot Water with a Brazed Plate Stainless Steel HX-Combi Only
- CH temperature up to 185°F (85°C)
- DHW temperature up to 159°F (65°C)
- 159 (65 deg C)
 - Field Supplied Tempering Valve Required

DHW Capacity :

Flow Rate at 40°F Temperature rise = 6.3 gal/min

Flow Rate at 70°F Temperature rise = 3.6 gal/min

Technical Data Table

Data	DWB-CCB150	DWB-CHB130	DWB-CHB100
Boiler Category	Category I & III	Category I & III	Category I & III
Type of Gas	Natural Gas	Natural Gas	Natural Gas
Minimum Input 0-2000 Ft	50,000 btuh	43,500 btuh	31,500 btuh
Minimum Input 2000-4500 Ft	45,000 btuh	39,000 btuh	28,300 btuh
Maximum Input 0-2000 Ft	150,000 btuh	130,000 btuh	100,000 btuh
Maximum Input 2000-4500 Ft	135,000 btuh	117,000 btuh	90,000 btuh
Max Inlet gas pressure	10.5" w.c.	10.5" w.c.	10.5" w.c.
Min Inlet gas pressure	3.5" w.c.	3.5" w.c.	3.5" w.c.
Manifold Gas pressure Max Input	5.12" w.c.	4.72" w.c.	4.72" w.c.
Manifold Gas pressure Min Input	0.59" w.c.	0.59" w.c.	0.59" w.c.
D.O.E. Heating Capacity	127,000 btuh	110,000 btuh	85,000 btuh
Net AHRI Output	110,000 btuh	96,000 btuh	73,000 btuh
Electrical input	120V/60 Hz./<12 A	120V/60 Hz./<12 A	120V/60 Hz./<12 A
Orifice Size 0-5500 Ft	1.35 mm	1.35mm	1.35mm
MAWP Water	43.5 Psig	43.5 Psig	43.5 Psig
Max Water Temp Setting	185 Deg F	185 Deg F	185 Deg F
Maximum Input LP 0-2000 Ft	150,000 btuh	130,000 btuh	100,000 btuh
Minimum Input LP 0-2000 Ft	55,500 btuh	49,000 btuh	36,000 btuh

Clearances – All Boilers

TABLE 1: BOILER CLEARANCES		
Dimension	Combustible Materials⁽¹⁾	Service^{(1) (2)}
Top (A)	16" (41 cm)	16" (41 cm)
Left Side (B)	0" (0 cm)	1" (3 cm)
Right Side (C)	0" (0 cm)	1" (3 cm)
Front (D)	0" (0 cm)	1" (3 cm)
Back (E)	0" (0 cm)	0" (0 cm)
Bottom (F)	0" (0 cm)	12" (30 cm)
Combustion Air / piping	0" (0 cm)	3/8" (1 cm)
Vent piping	6" (15 cm)	6" (15 cm)

⁽¹⁾ Required distances measured from boiler jacket.
⁽²⁾ Service, proper operation clearance recommendation

Components – All Boilers

Modulating Fan (3:1)
With Air Pressure
Sensor

Copper Heat
Exchanger with high
temperature
corrosion resistant
protective film

Modulating Gas
Valve (3:1)

Stainless Steel
Burners

3 speed pump with
anti-seize
every 24 hours pump
will run for 5 seconds

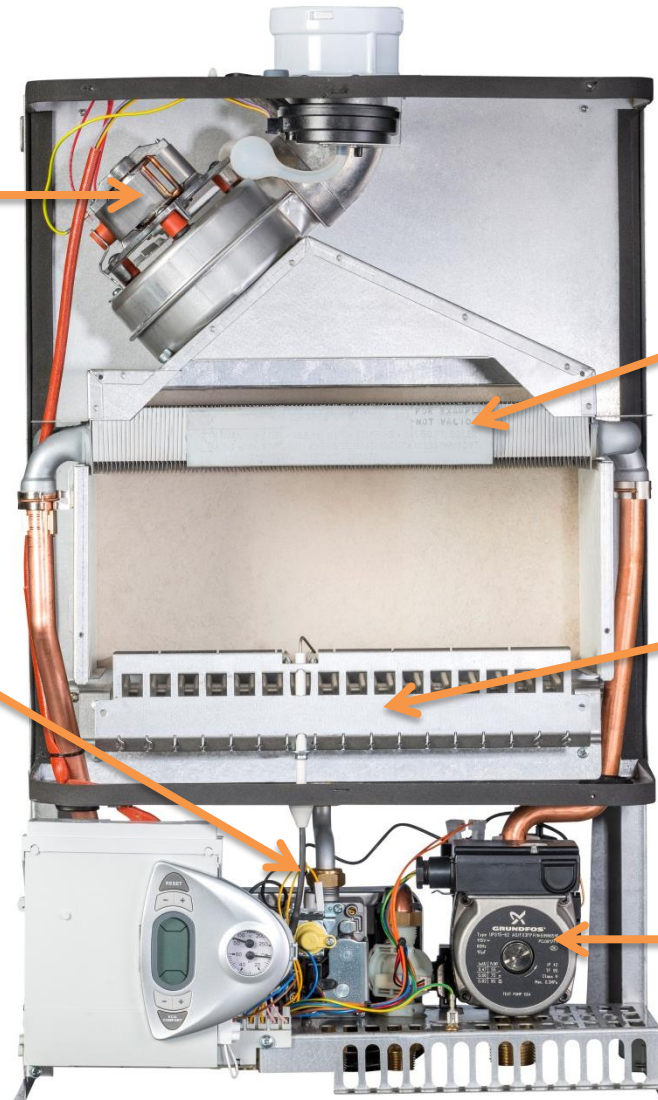

Components – Combi Boiler

Note:

DHW Capacity :

@ 40°F Rise= 6.3 gpm

@ 70°F Rise= 3.6 gpm

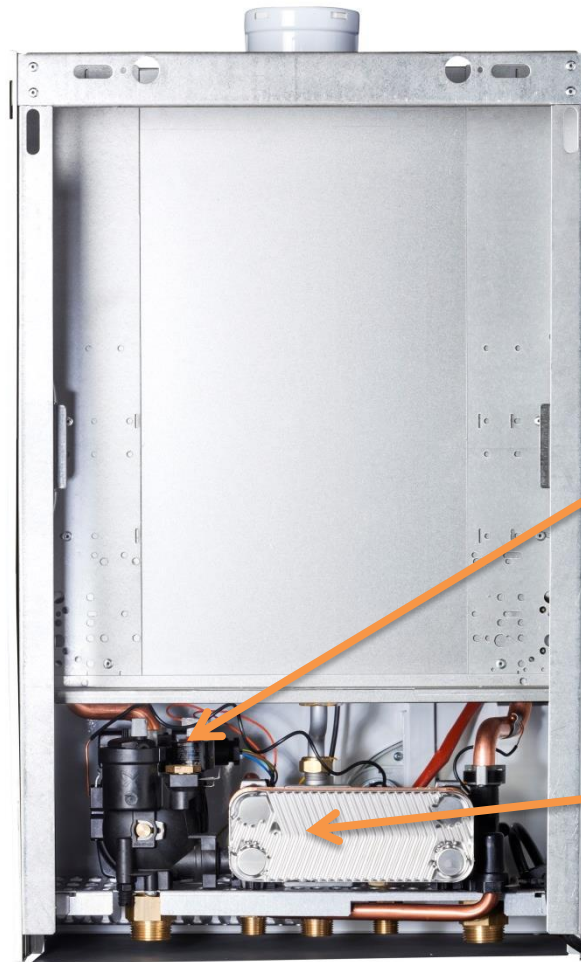

24 volt diverting
valve – priority for
Domestic Hot
Water

DHW Stainless Steel
Brazed Plate Heat
Exchanger

Back of Boiler

Main Components – CCB 150

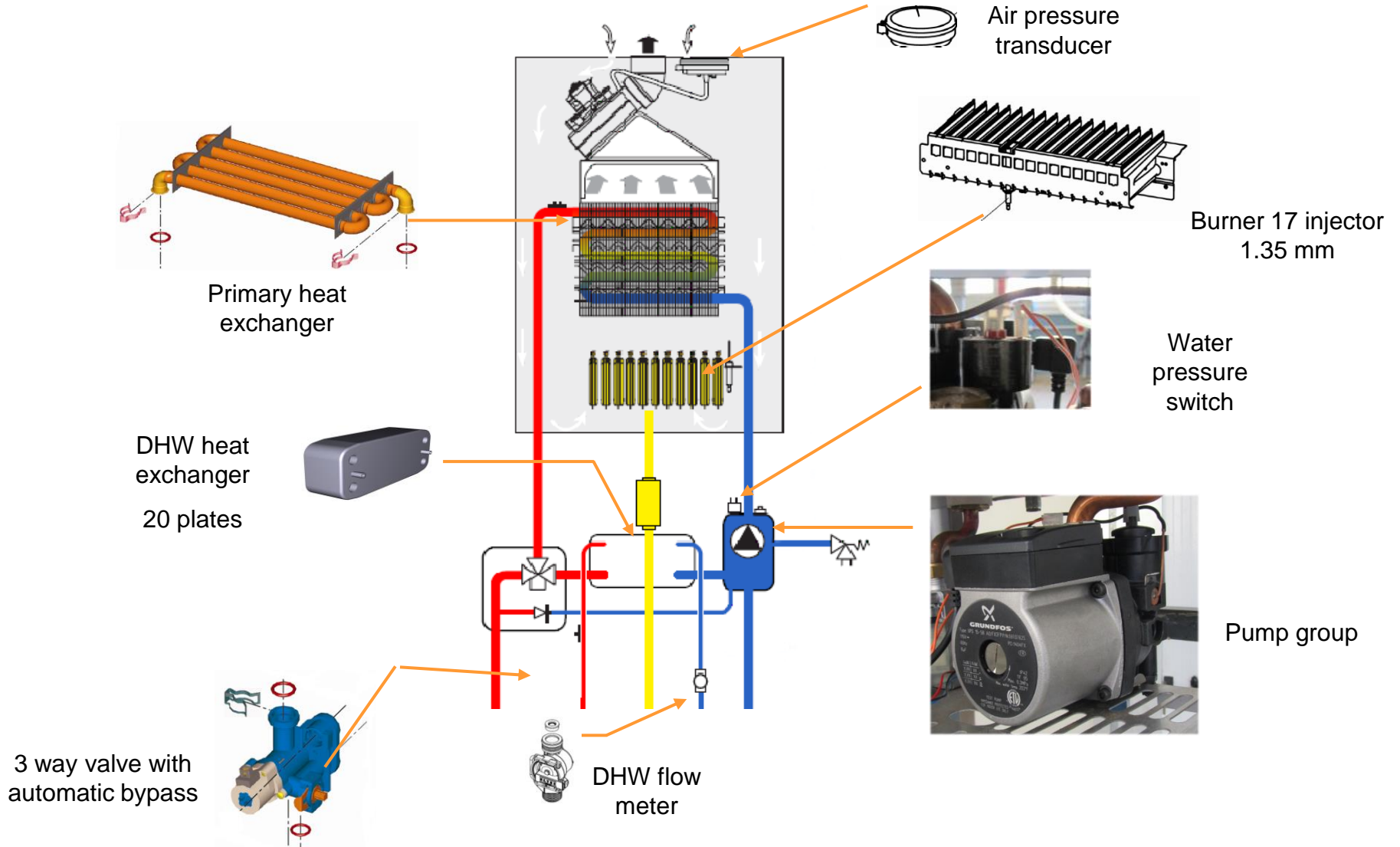

Plumbing Circuit CCB - 150

- 8 Domestic Hot Water Outlet
- 9 Domestic Cold Water Inlet
- 10 Heating System Supply
- 11 Heating System Return
- 27 Copper Exchanger for Heating and Hot Water
- 32 Heating Circulating Pump
- 36 Automatic Air Vent
- 42 DHW Temperature Sensor
- 95 Diverter Valve
- 114 Water Pressure Switch
- 136 Flow Meter
- 241 Automatic Bypass
- 278 Double Sensor (Safety + Heating)

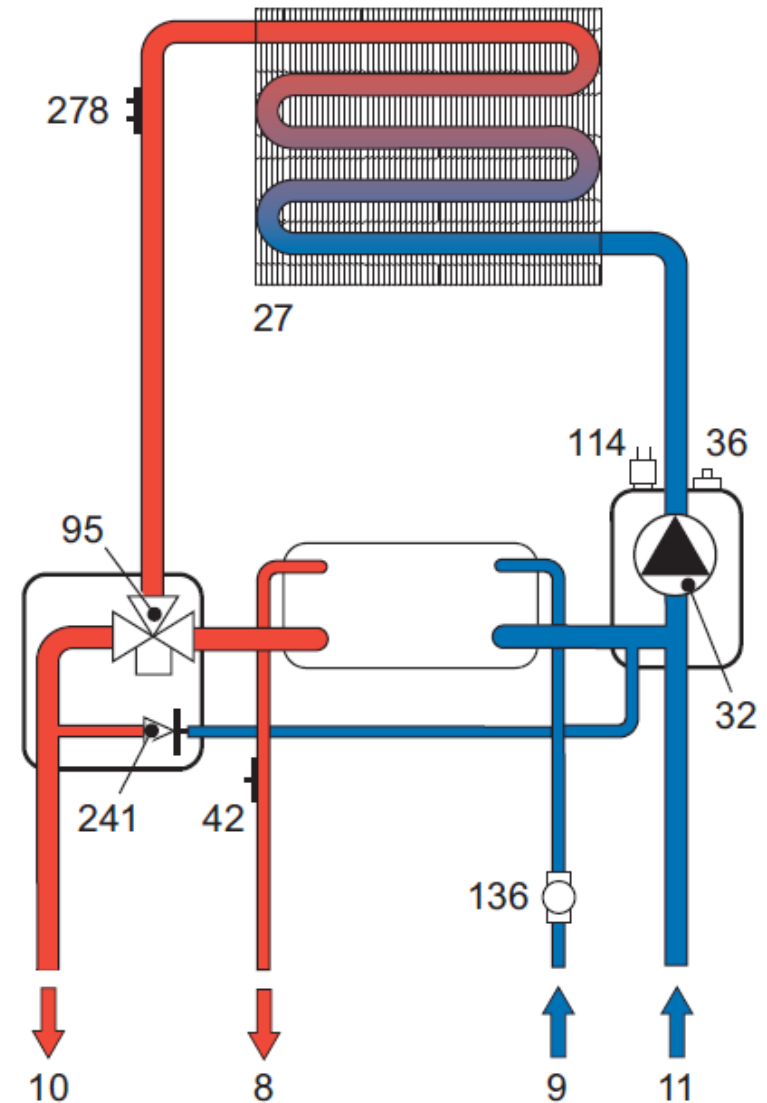

Plumbing Circuit CHB-100/130

- 10 System Delivery
- 11 System Return
- 27 Copper Exchanger for Heating and Hot Water
- 32 Heating Circulating Pump
- 36 Automatic Air Vent
- 95 Diverter Valve
- 114 Water Pressure Switch
- 209 Hot water tank delivery
- 210 Hot water tank return
- 241 Automatic bypass
- 278 Double Sensor (Safety + Heating)

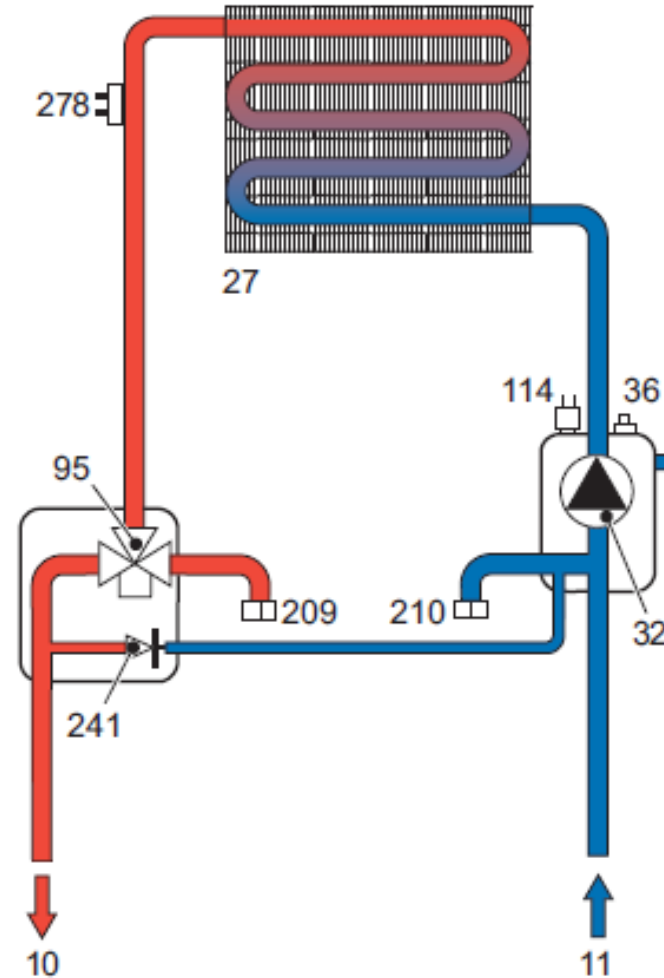

Models CHB-100 /130

The CHB-100 & 130 can be directly connected to an indirect tank with the optional DHW Sensor Kit.

- Coat Sensor with included ThermoPaste
- Insert Sensor into well
- Secure with clip provided



Models CHB-100 /130

To install optional DHW storage tank sensor:

Remove resistor from terminal block then wire in sensor

Change parameter P02 to value 2

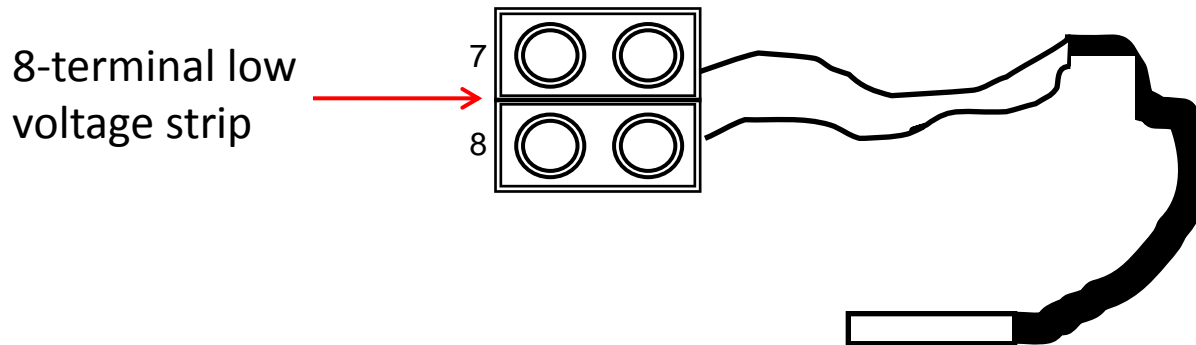

Par.	Description	Default
P01	Gas type selection (0=Nat, 1=Lpg)	0
P02	DHW configuration	2

Connection to DHW Tank CHB-100/130

- 8 Domestic hot water outlet
- 9 Cold water inlet
- 10 System delivery
- 11 System return
- 95 3-way valve
- 209 Hot water tank delivery
- 210 Hot water tank return

Note: Connection to an indirect tank requires an optional sensor kit for proper operation. Do not use standard Aquastat. **Kit # 550002958**

- Disconnect power from boiler.
- Remove resistors located on terminals 7 and 8.
- Connect optional indirect DHW tank sensor to PCB terminals 7 and 8.
- Reconnect Power – Boiler will then recognize that a tank sensor has been connected

Parameter P02 in TS Menu = 2

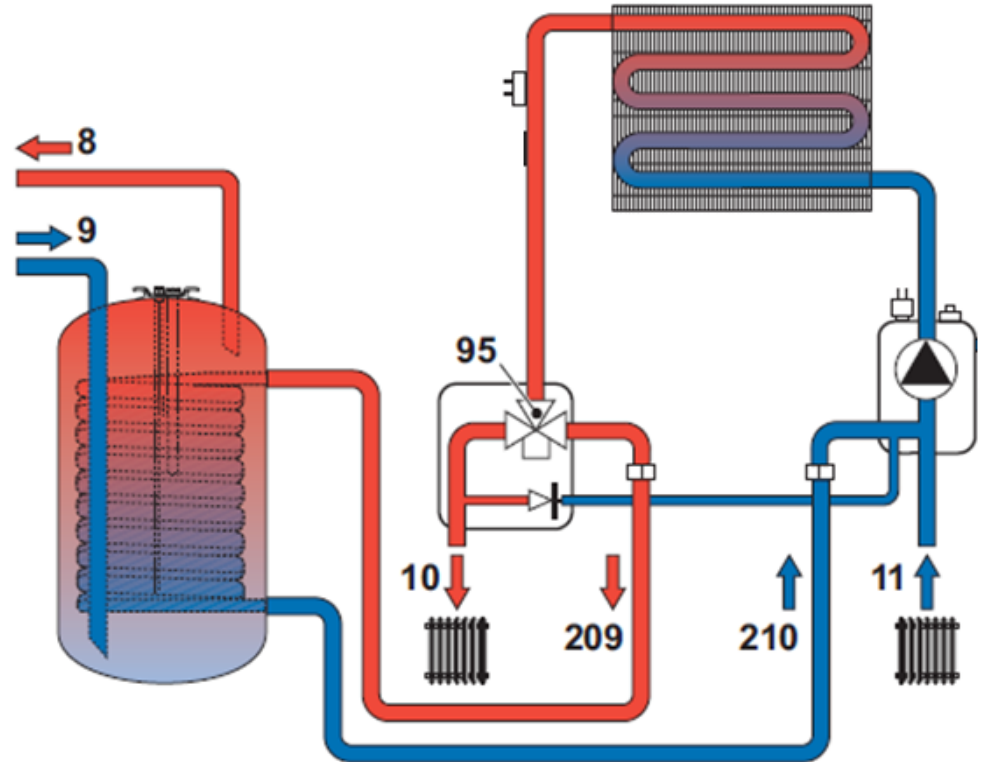

Connections CCB-150

View-Bottom of Boiler

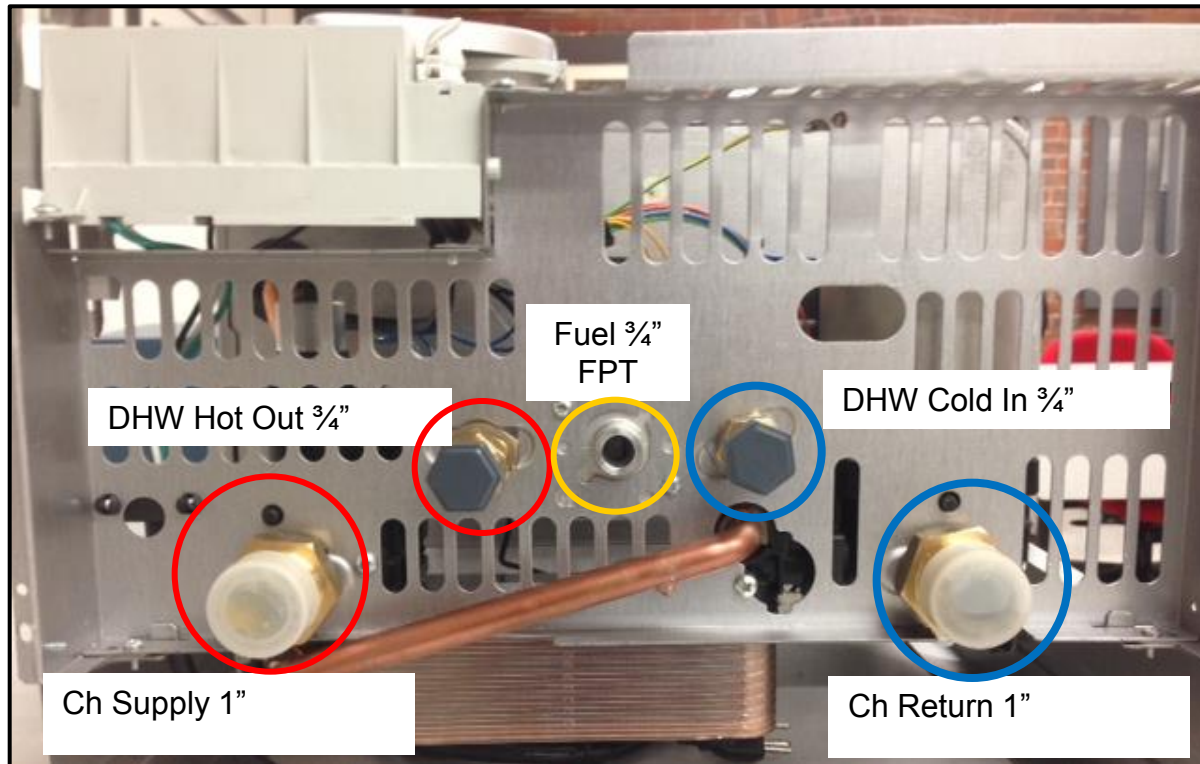

Connections CHB-100/130

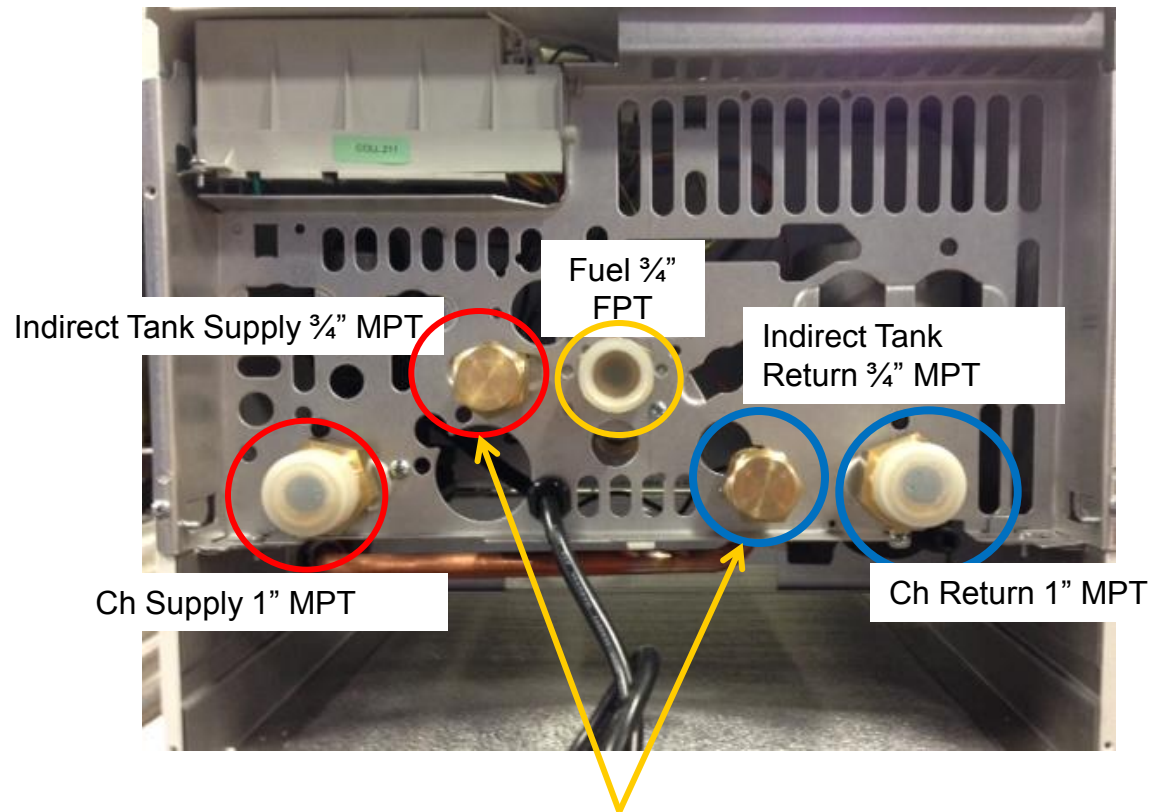

The Heating only boilers have two dedicated connections for piping to an Indirect tank. The boilers have built in priority for Indirect tank heating. Requires the optional DHW Sensor kit p/n 550002958.

Safety Relief Valve – All Models

WARNING

Burn and Scald Hazard. Safety relief valve could discharge steam or hot water during operation. Install discharge piping per these instructions. Failure to do so could result in death or serious injury.

Supplied Safety Relief Valve:
30 PSI

Safety Relief Valve

Gas Shutoff
Valve in Open
position

Pipe to within 6"
to floor per local
code

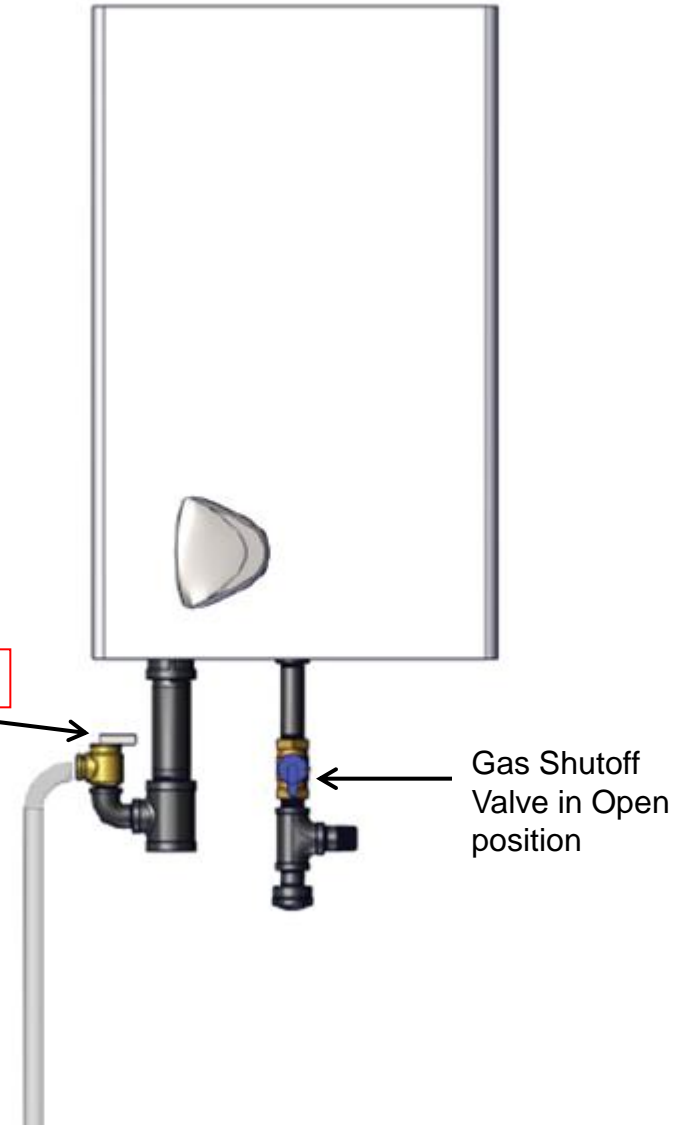

Combustion Air and Venting Pipe

Table 2 – Combustion Air and Vent Pipe Fittings Category I (Chimney Vent)

Item	Material	Standards
Vent Pipe & Fittings	Type B Vent	UL 441, ULC S605
	Masonry Chimney – must conform to proper sizing and materials	National Fuel Gas Code, ANSI Z223.1 / NFPA 54
Combustion Air	Stainless Steel, PVC, CPVC, PP, Aluminum	ANSI / ASTM D2564, ANSI / ASTM F493, UL 1738 / ULC636-08

Table 3 – Combustion Air and Vent Pipe Fittings

Type	Item	Diameter	Min Length	Max Length	Material	Standards
Direct Vent	Vent	3"	5 ft	65 ft	AL294C Stainless Steel, Aluminum	UL1738, ULC S636
	Air intake	3"	5 ft	65 ft	Stainless Steel, PVC, CPVC, PP, Aluminum	
Category III	Vent	3"	5 ft	65 ft	AL294C Stainless Steel, Aluminum	UL1738, ULC S636

Equivalent Length of Venting Components:

5 ft. equivalent for a 3" 90° elbow.

2 ½ ft. equivalent for a 3" 45° elbow.

Combustion Air and Venting Pipe

These items shipped loose with boiler and must be field installed.

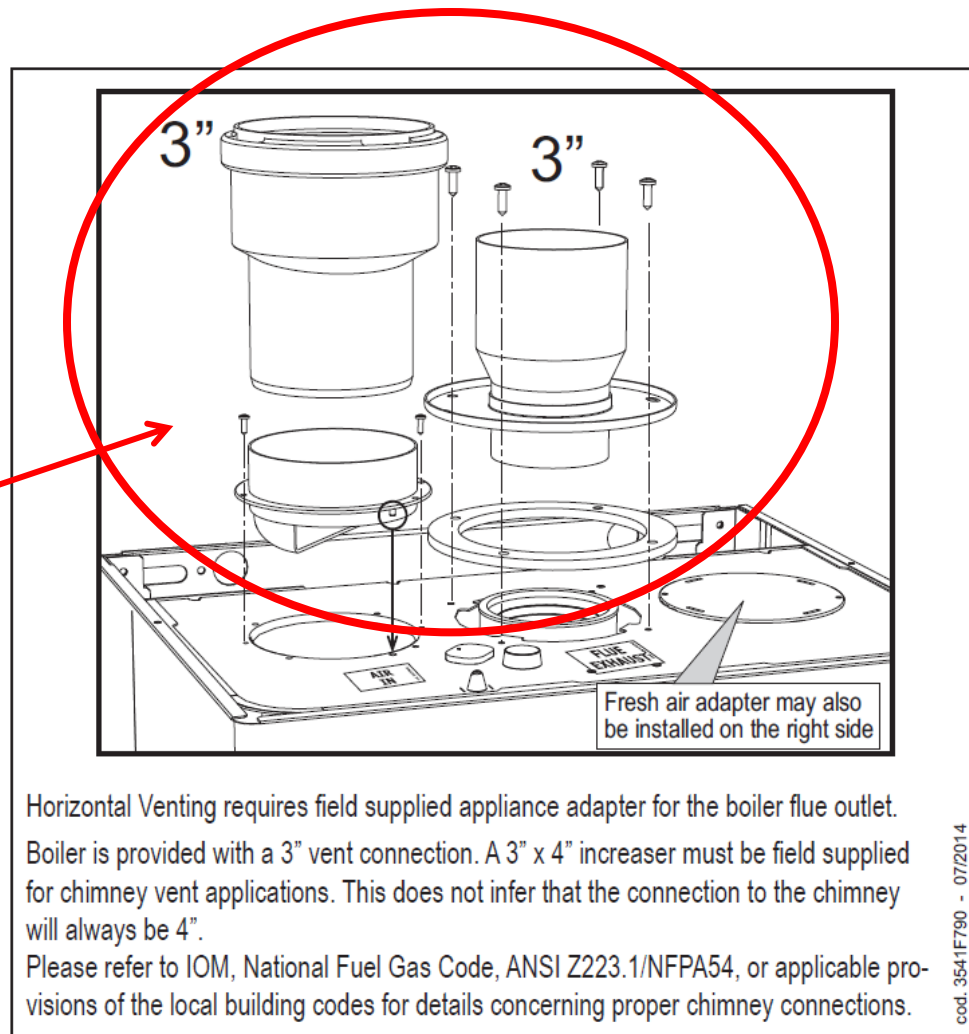

Combustion Air and Venting Pipe



Supplied with boiler

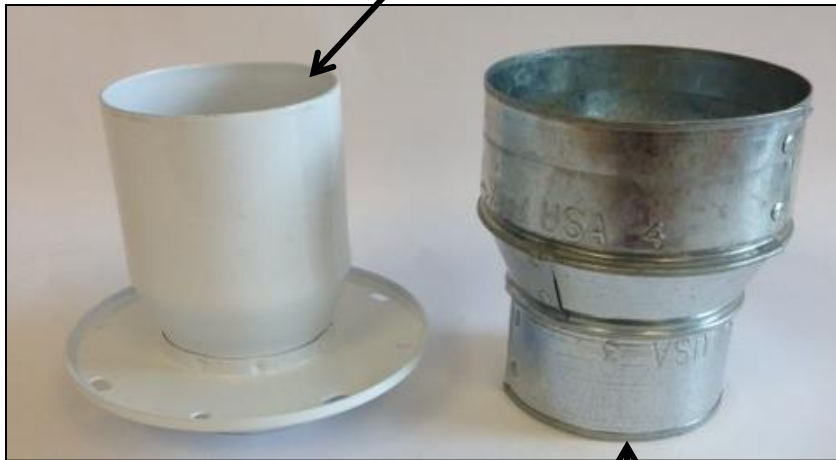

Field Sourced
Increaser



Combustion Air
adapter Accepts 3"
PVC



Combustion Air and Venting Pipe

Two Pipe Venting

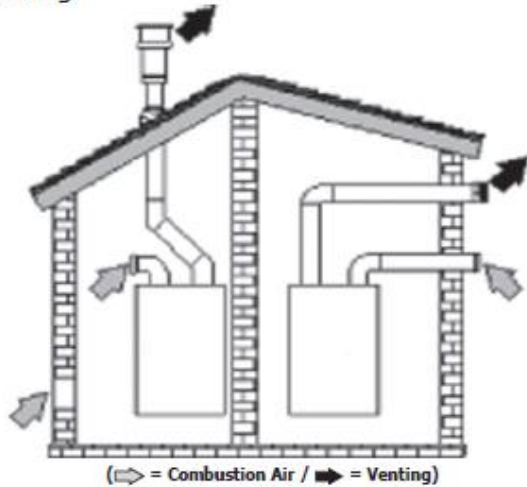

Chimney Venting with Room Air
Single Wall

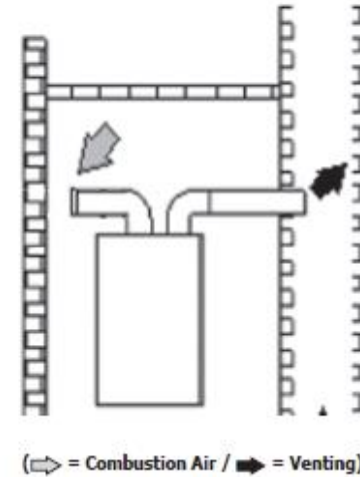

Chimney Venting with Outside Air
Single Wall

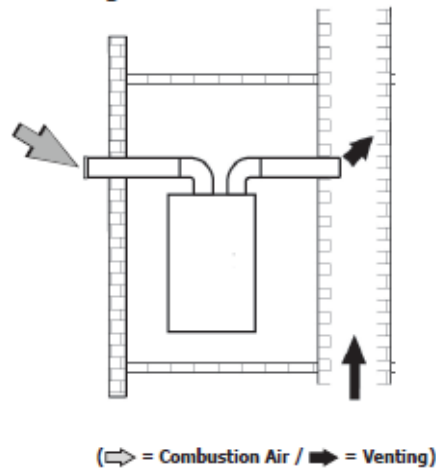

Combustion Air and Venting Pipe

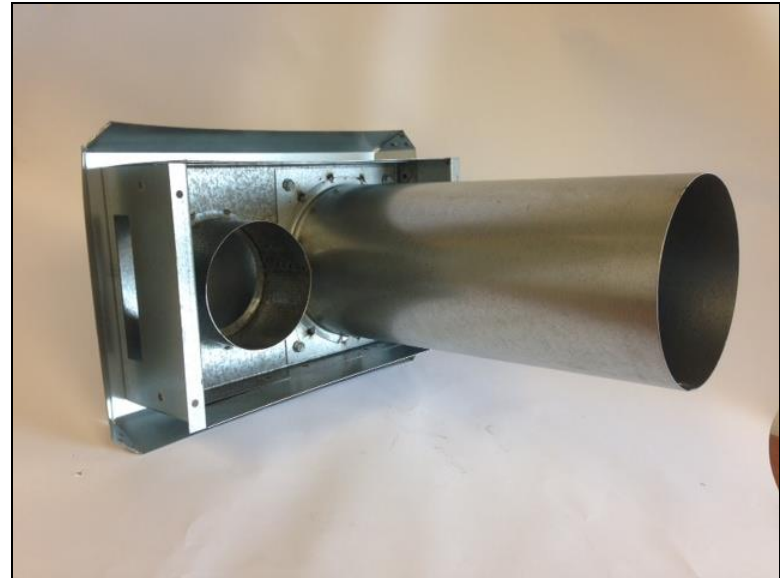

Combustion Air and Venting Pipe

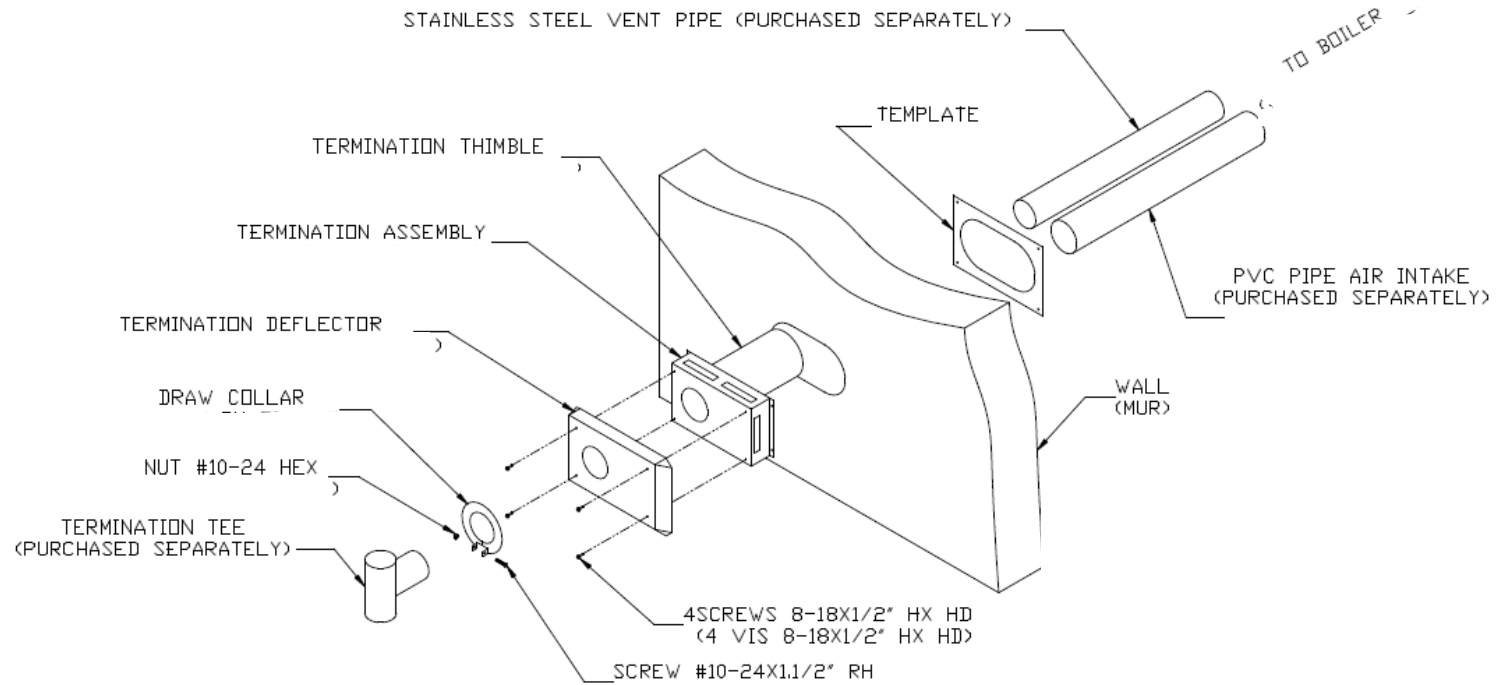

Water Pressure Switch – All Models

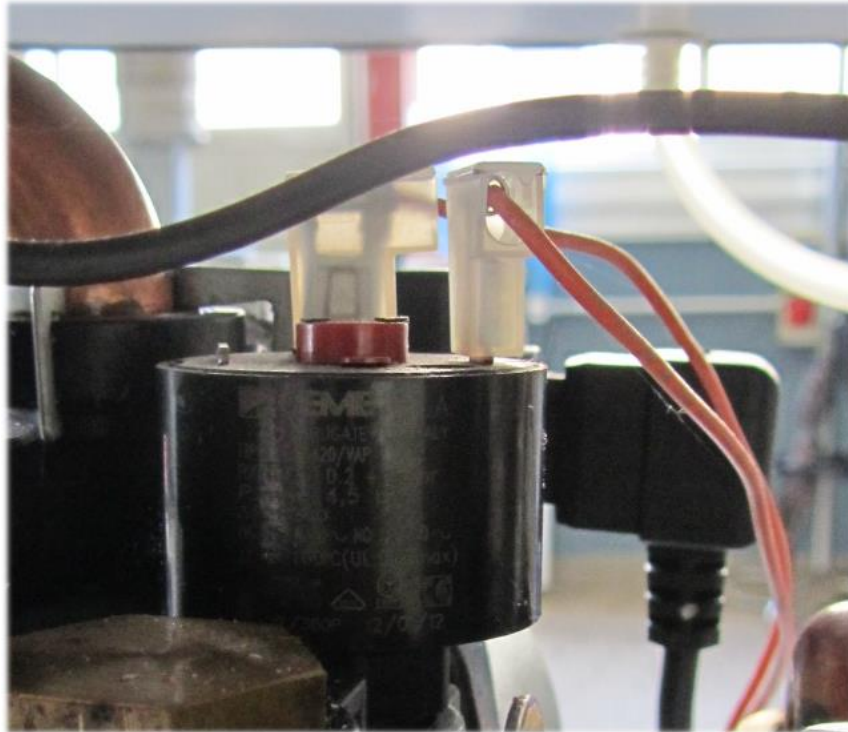

Heating System Water Pressure Switch

5.8 PSI open contact → (fault f37)

10.1 PSI close contact → fault automatically reset

Flow Meter – CCB 150 Only

Flow orifice – 4 GPM flow rate through brazed plate

Fixing spring: Remove to replace / clean turbine, Pull to remove turbine

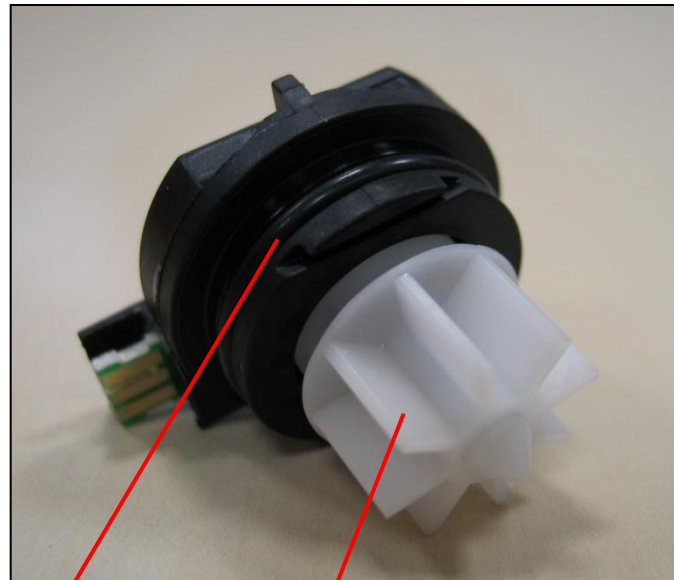
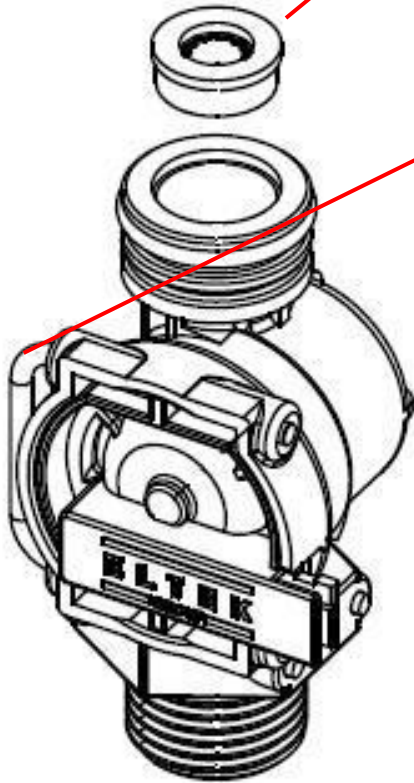

O-Ring

Turbine

The flow meter senses the flow rate of hot potable water and adjusts firing rate accordingly.

DHW Min flow rate to activate burner is 0.69 gpm

Burner shuts off if flow rate drops below 0.46 gpm

Circulation Pump

Losses of load / head of circulators

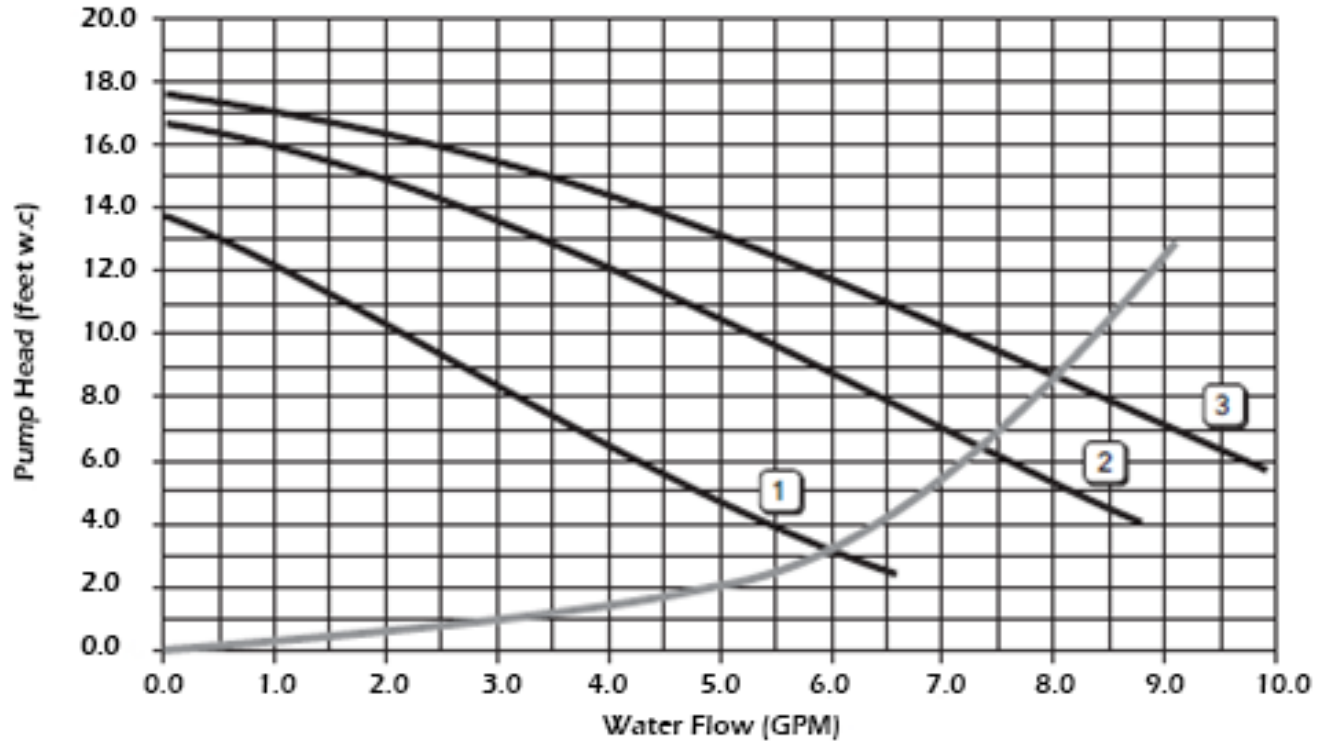

A = Boiler losses of head
1 – 2 – 3 = Circulator speed

Pump group with automatic air vent and water pressure switch.

Same pump for all models.



3 Way Diverter Valve

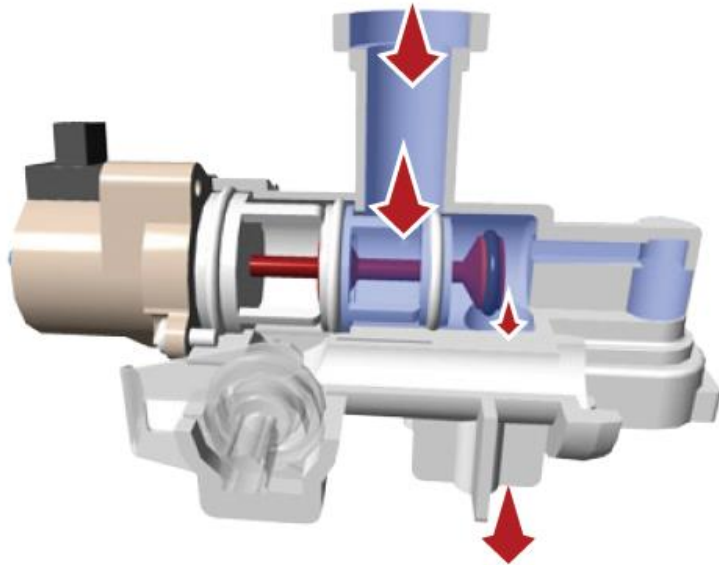
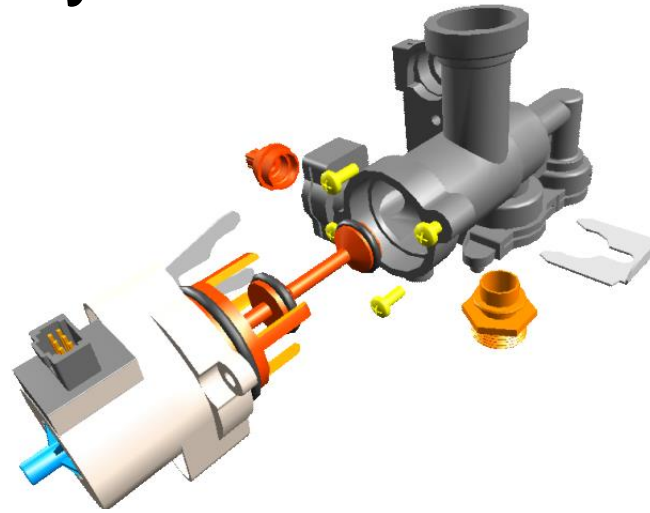

Central Heating Mode

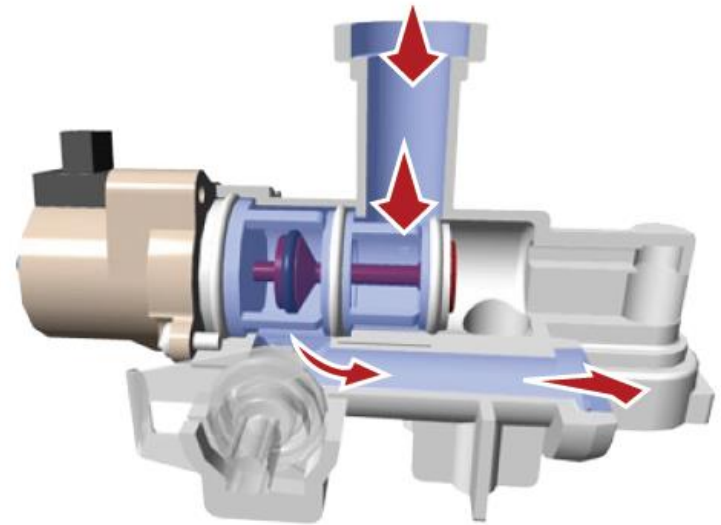

DHW Mode

3 Way Diverter Valve

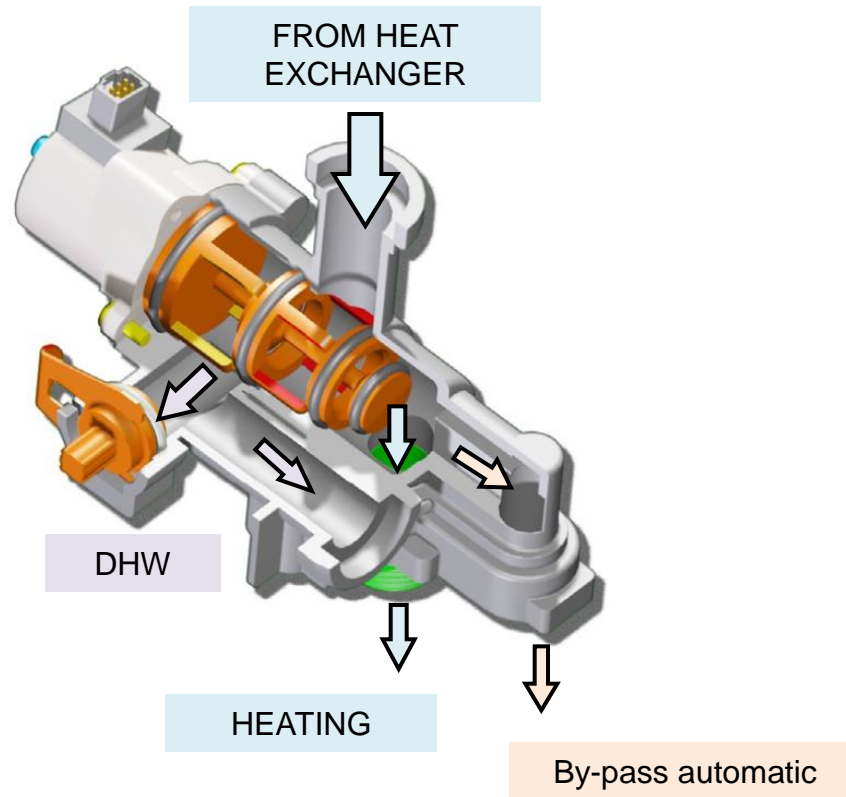

3 way valve is driven from pcb and uses a stepper motor low voltage.

Every 24 hours the 3 way valve automatically changes from DHW position to CH (anti sticking protection).

In OFF mode 3 way valve is in the middle.

Fan and Venturi – All Models



120 Vac Fan with phase cutting to control the speed according to air pressure transducer signal.

Venturi is placed inside the fan. The Venturi produces a dynamic negative pressure signal which is sent to the air pressure transducer.

Air Pressure Transducer – All Models

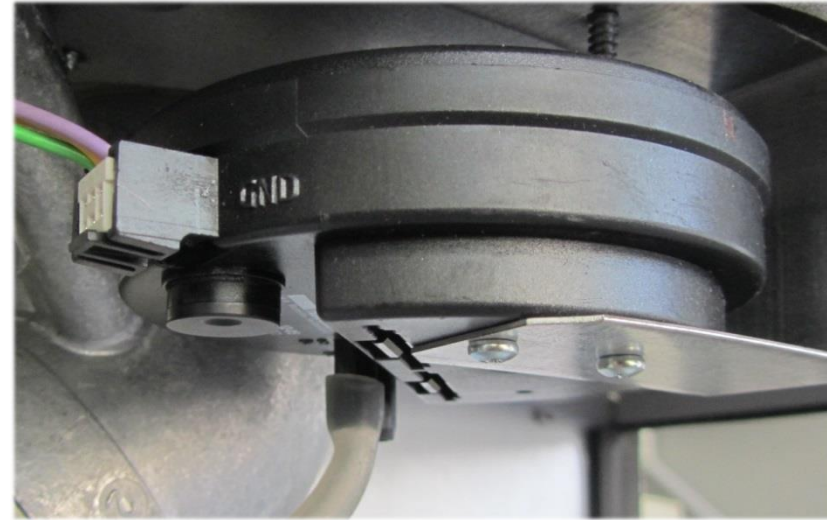
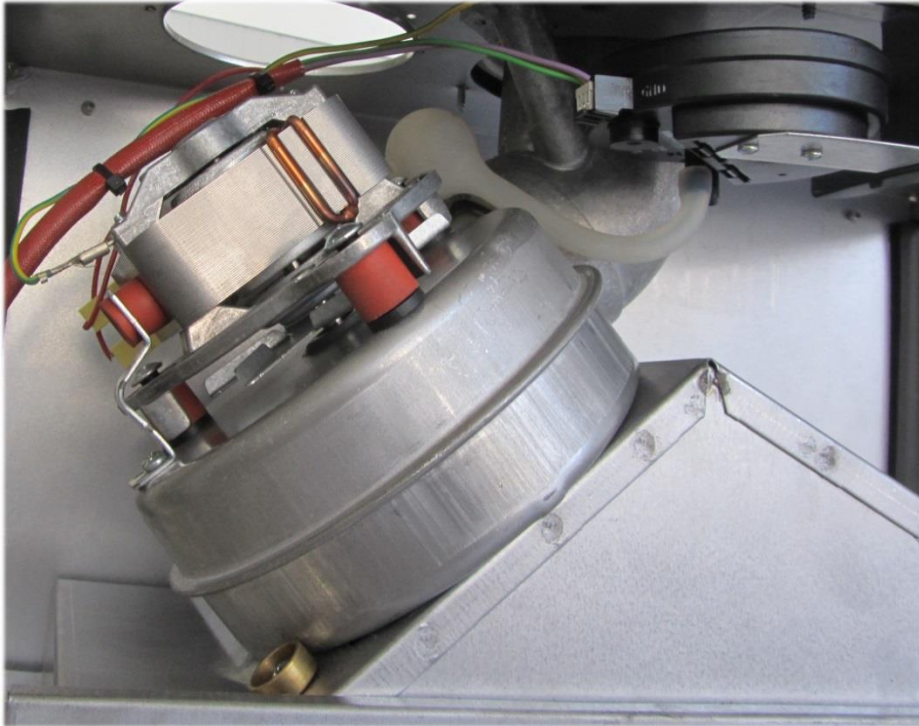

P2 = Venturi

P1 = Sealed chamber

Air pressure transducer sends the PCB a signal to drive the fan:

- With short chimney fan speed will be lower
- With long chimney fan speed will be higher

This is to compensate for chimney conditions & results in constant efficiency of the boiler @ max and min power

Air - Gas Automatic Regulation

To optimize combustion it is necessary to control air & gas flow

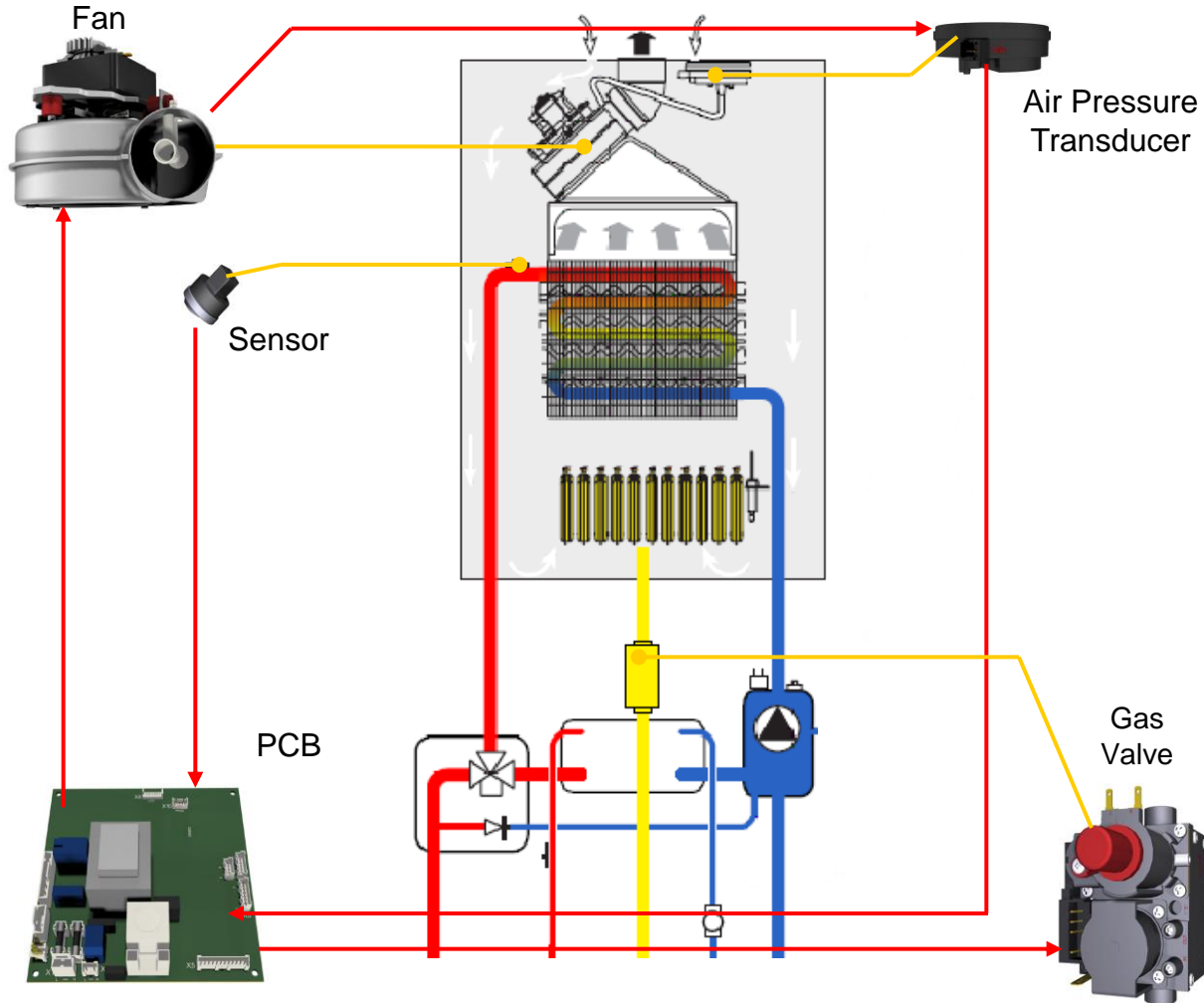

- When there is a heating demand the PCB sends power to the fan.
- Air flow is detected from air pressure transducer. Air flow is converted to electric signal that goes to PCB.
- The PCB adjusts gas for detected air flow.

Sensors – CCB 150

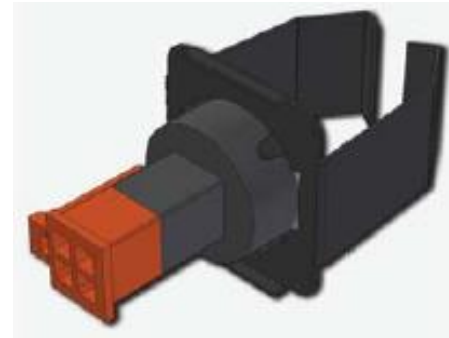
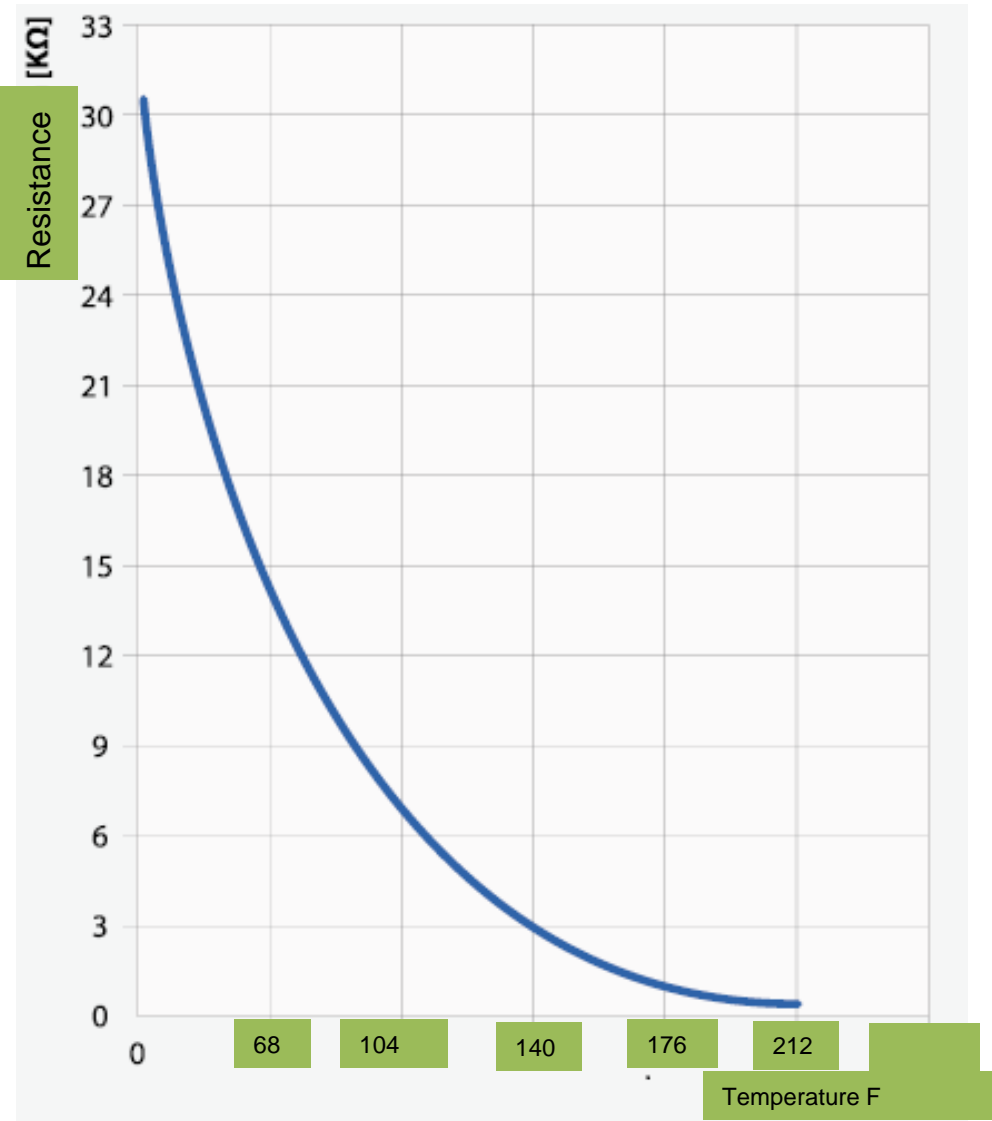

All models

1 CH Sensor (NTC)

Double sensor protection:

Flow

Frost protection

Eco-comfort

Safety

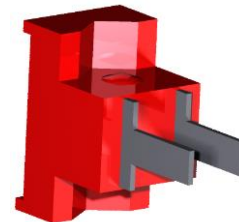

Combi CCB150 Only

1 DHW Sensor (NTC)

Sensors – CCB 150

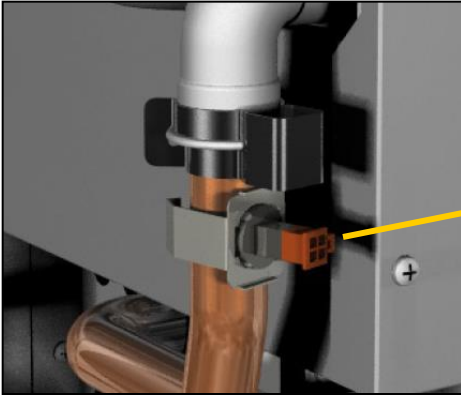

CH
Double NTC sensor

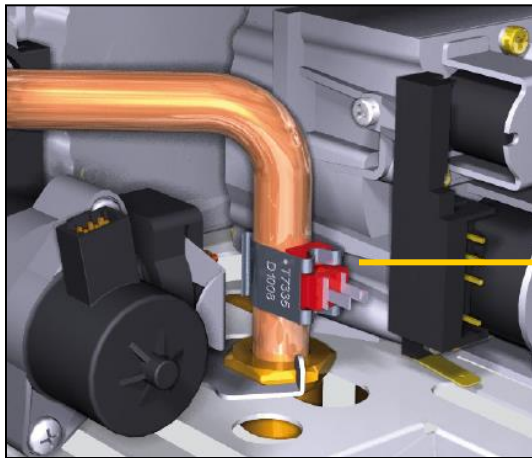

DHW
NTC sensor

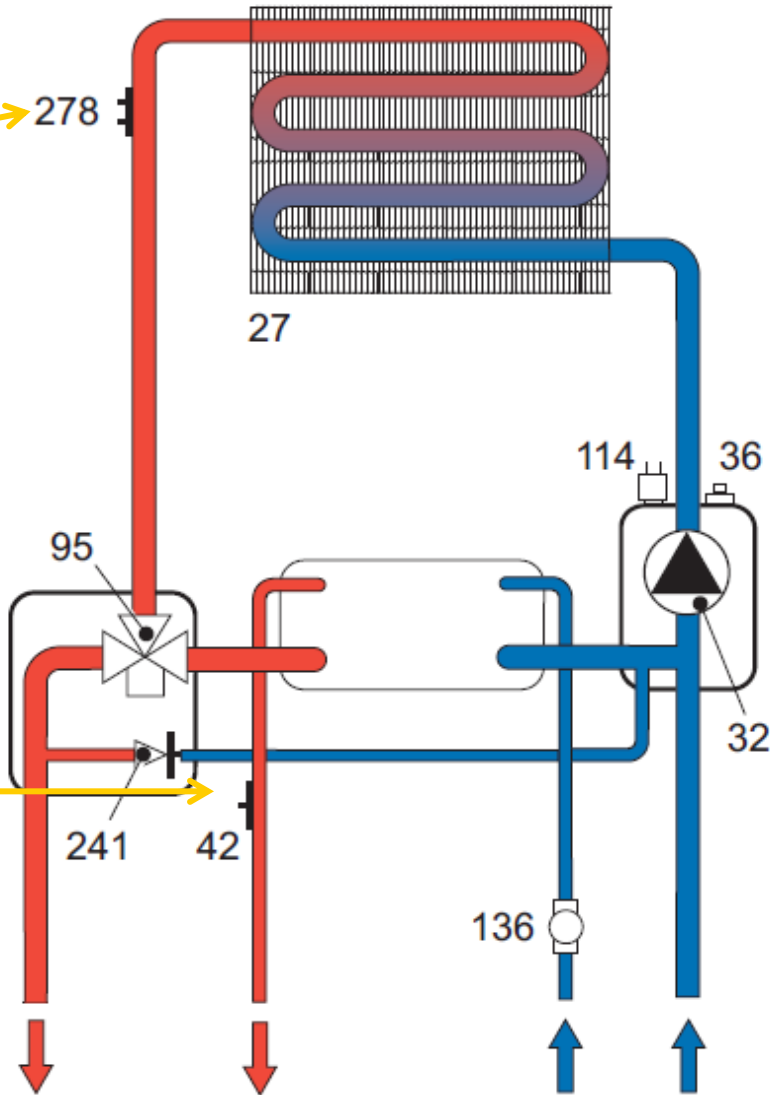

Electrical Connections

WARNING

Electrical shock hazard. Turn OFF electrical power supply at service panel before making electrical connections. Failure to do so could result in death or serious injury.

Central Heating Thermostat

- A. Use thermostat or boiler system control with dry contacts rated 0.5 amps @ 120 VAC. Boiler control does not provide 24 VAC power to central heating thermostat. Do not use to power 24 VAC thermostat.
- B. Locate and install thermostat per manufacturer's instructions. Maximum wire length is 330 ft (100m) for 22 ga. Wire.
- C. Connect wires to terminals 1 and 2 as shown in figure 17. Wires are interchangeable.

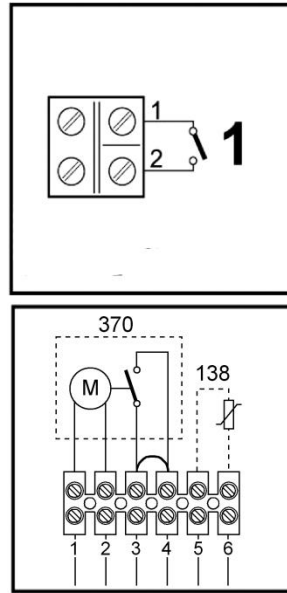

CCB-150

Two Separate Terminal Blocks

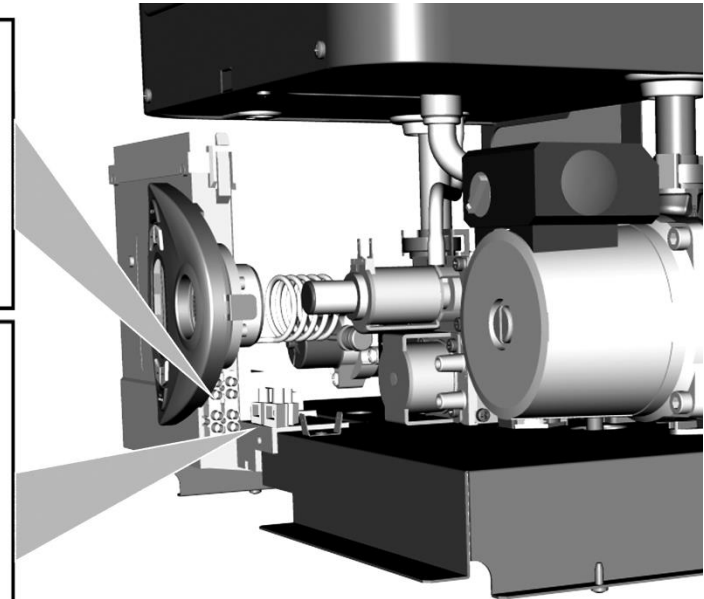

1 = Thermostat or dry contacts
138 = Optional kit – External Outdoor Reset Sensor

LWCO Connections ON 6-PIN Terminal block
1 & 2: 120 Vac power to LWCO
3 & 4: Dry contact switching from LWCO

Wiring Diagram – CCB 150

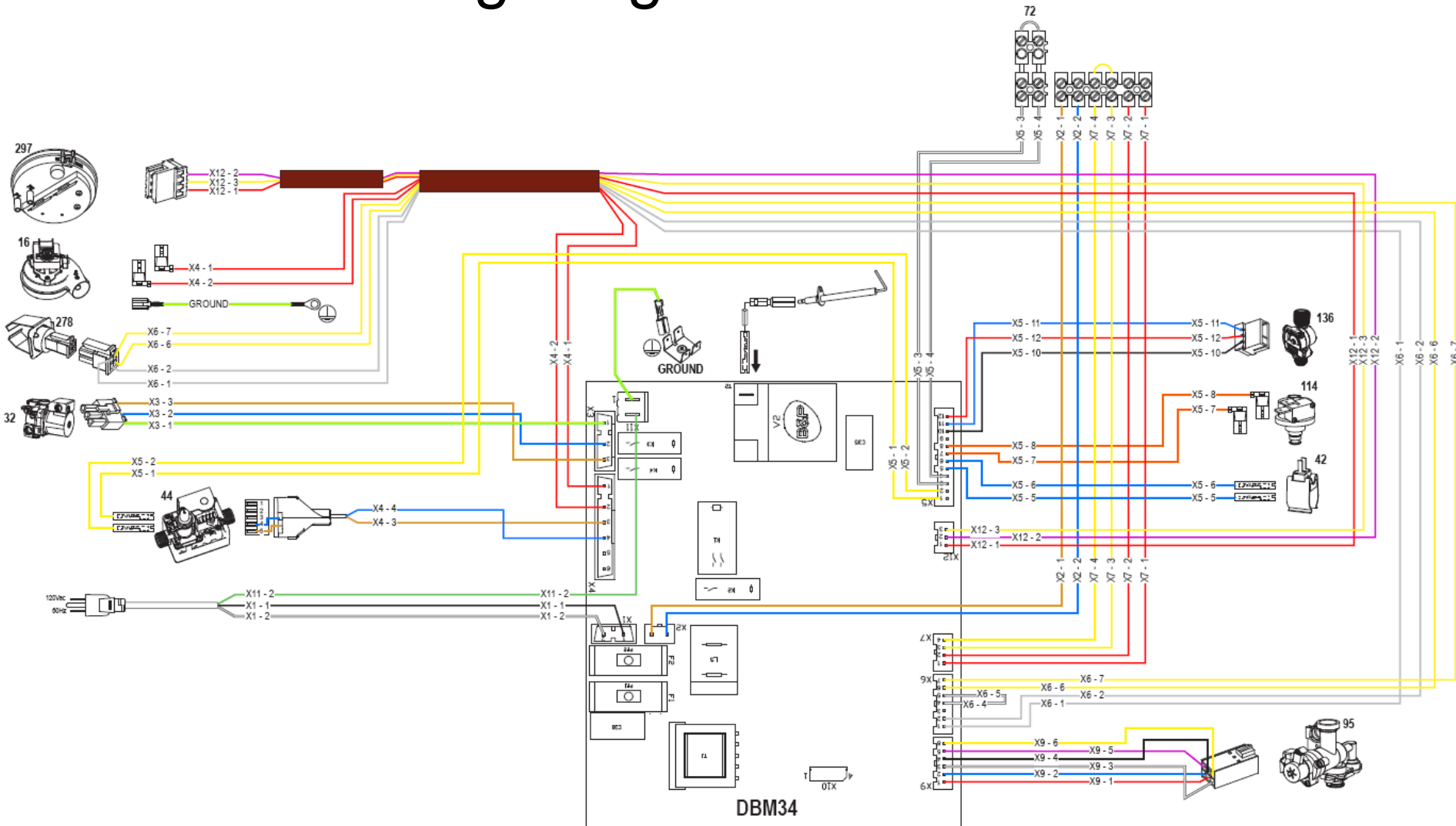

Note: View of board shown with PCB cover down

Ladder Diagram – CCB 150

- 16 Modulating fan
- 32 Heating circulating pump
- 42 DHW temperature sensor
- 44 Gas valve
- 47 Modulation Regulator
- 72 Room thermostat
- 81 Ignition/detection electrode
- 95 Diverter valve
- 114 Water pressure switch
- 136 Flow meter
- 138 External probe - **Optional**
- 278 Double sensor (Safety + Heating)
- 297 Air pressure transducer
- 370 LWCO **Field Supplied**

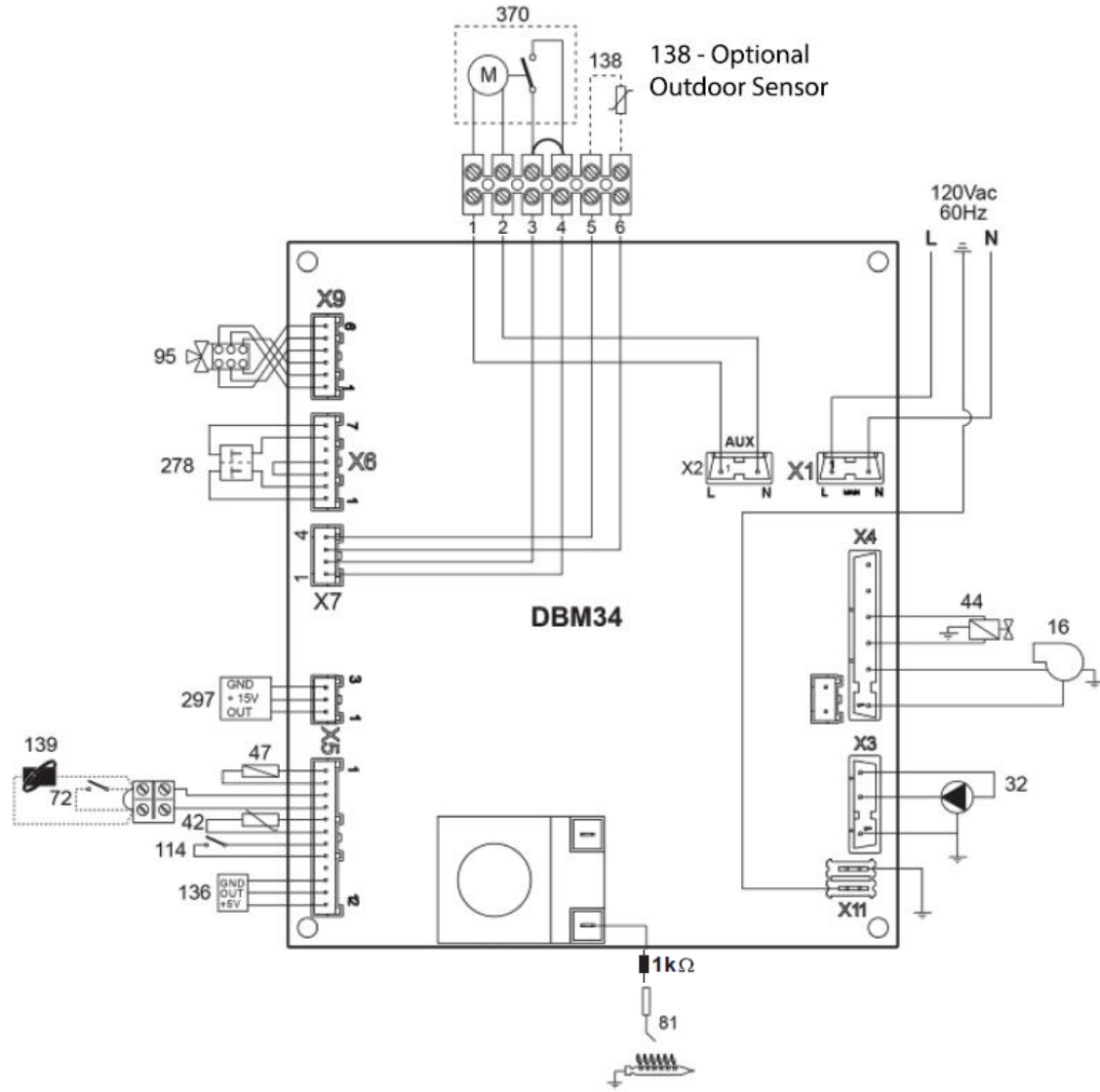

Wiring Diagram – CHB 100/130

- 16 Modulating fan
- 32 Heating circulating pump
- 44 Gas valve
- 47 Modulation Regulator
- 72 Room thermostat
- 81 Ignition/detection electrode
- 95 Diverter valve
- 114 Water pressure switch
- 138 External probe - **Optional**
- 278 Double sensor (Safety + Heating)
- 297 Air pressure transducer
- 370 LWCO **Field Supplied**

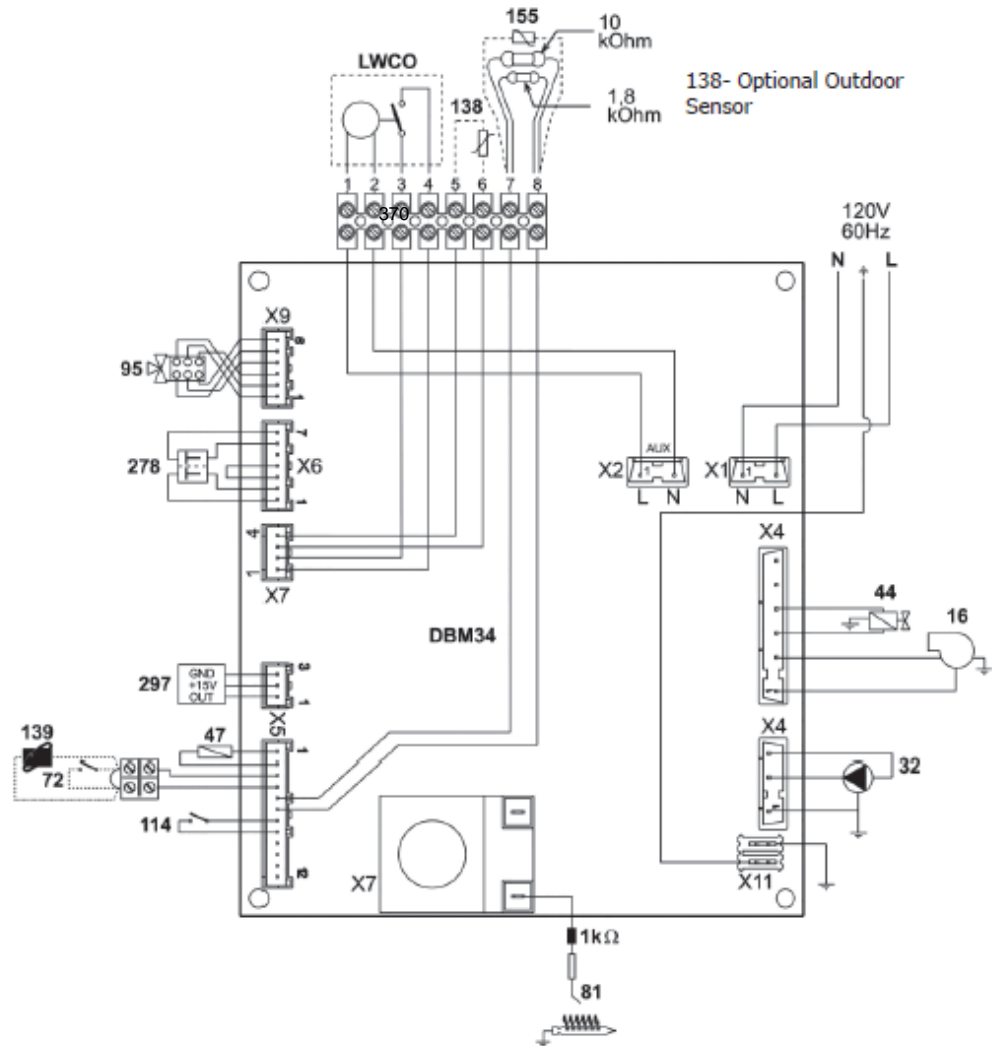

Important: Before connecting the room thermostat, remove the jumper on terminal block.

Ignition Lockout

Natural Gas Boilers:

The Boiler will attempt 3 tries for ignition then will lockout .

LP Gas Boilers:

The Boiler will attempt only once for ignition then will lockout.

Gas valve

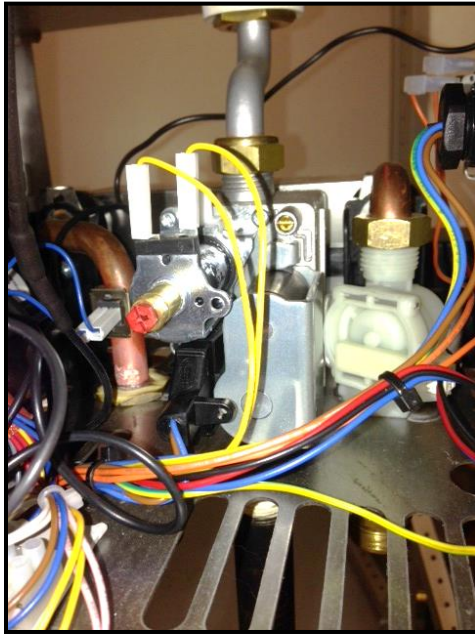

Note:

Gas valve is a positive pressure - fully modulating design. Firing rate is infinitely variable from 33% to 100 % of full firing rate.

Gas valve

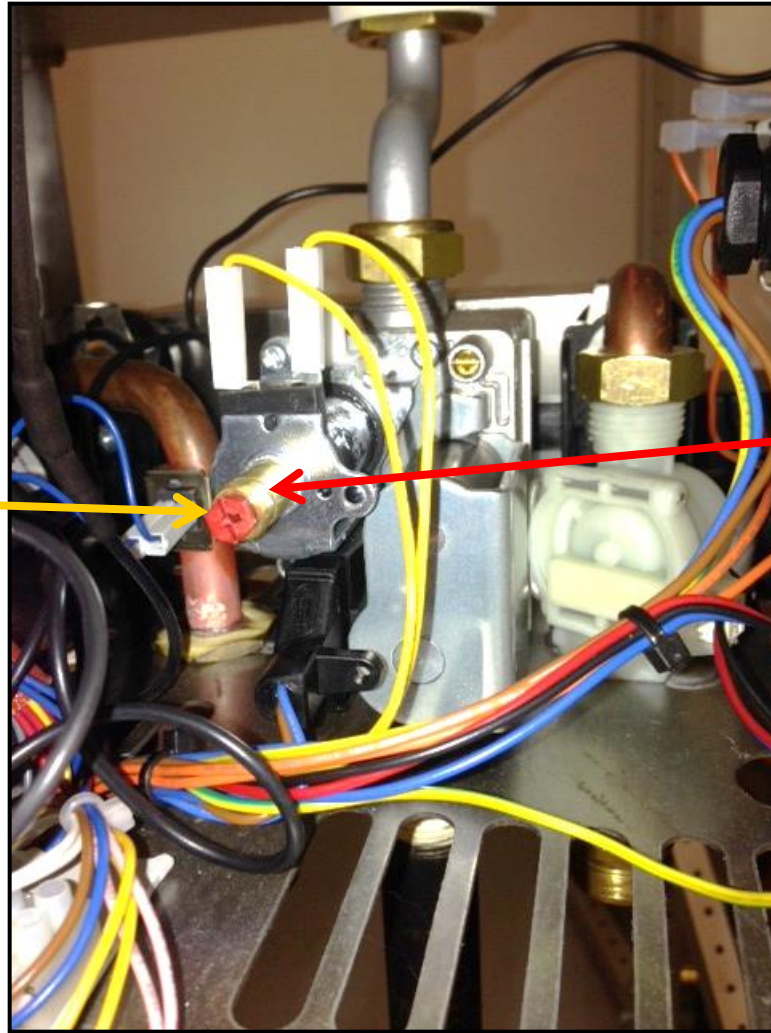

Minimum
Adjustment – Red
Screw Slotted

Maximum
Adjustment – gold
Hex nut

Burner Pressure Adjustment – All Models

Gas Supply Pressure	
Natural Gas	
Min.	Max.
3.5" w.c. (0.7 kPa)	14" w.c. (3.3 kPa)

Two sampling points are available at top of the boiler, one for venting and the other for combustion air.
 To sample:
 Open the air/vent outlet plug.
 Insert probes all the way in.
 Turn on TEST mode, wait 10 minutes for boiler to stabilize;
 Take measurement.

- A Pressure point upstream
- B Pressure point downstream
- C Modureg electrical connection
- D Protection cap
- E Minimum pressure adjustment
- F Modureg
- G Minimum pressure adjustment
- I Gas valve electrical connection
- N Compensation tube

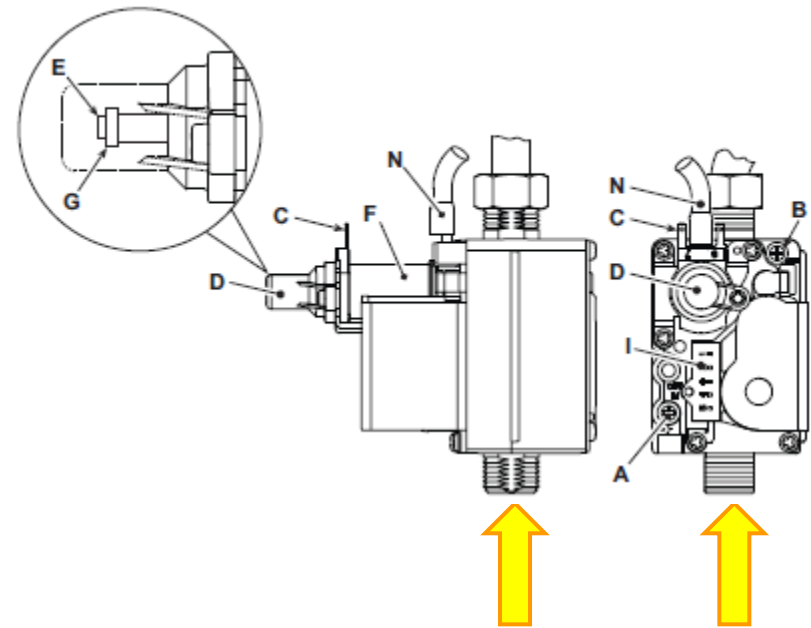

Data	CCB150	CHB130	CHB100
Max Inlet gas pressure	10.5" w.c.	10.5" w.c.	10.5" w.c.
Min Inlet gas pressure	3.5" w.c.	3.5" w.c.	3.5" w.c.
Manifold Gas pressure Max Input	5.12" w.c.	4.72" w.c.	4.72" w.c.
Manifold Gas pressure Min Input	0.59" w.c.	0.59" w.c.	0.59" w.c.

Burner Pressure Adjustment – All Models

Check Combustion Natural Gas

1. Measure input. English units turn off gas to all other appliances.
 - Activate some heating zones to dissipate heat
 - Set boiler on high fire
 - Use ½, 1 or 2 cu ft dial on gas meter. Measure time required for one or more complete revolutions. Measure time for 1-2 minutes.
 - Calculate input.

$$\text{Input (MBH)} = \frac{3600 \times \text{cu ft}}{\text{seconds}}$$

Example: Gas flow from

Meter = 2 cu ft

Measured time = 72 seconds

$$\text{Rate (MBH)} = \frac{3600 \times 2 \text{ cu ft}}{72 \text{ seconds}} = 100 \text{ MBH}$$

Test Ports

Vent Gases
Test Port

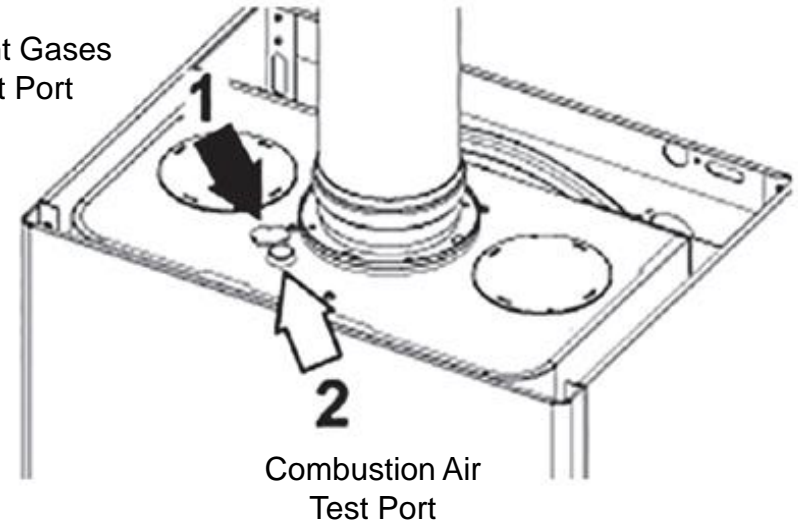

Quantity of Orifice's
 CCB150 = 17
 CHB100 = 11
 CHB130 = 15
 NG Orifice size 1.35mm
 LP Orifice size 0.85mm

Combustion Minimum / Maximum		
		Natural Gas
Max. input	CO2 at (100%)	7.3 – 7.8
Min. input	CO2 at (33%)	4.6 – 5.4

LP Conversion



Remove Sealed
Combustion Chamber
Outer Cover

Step 1

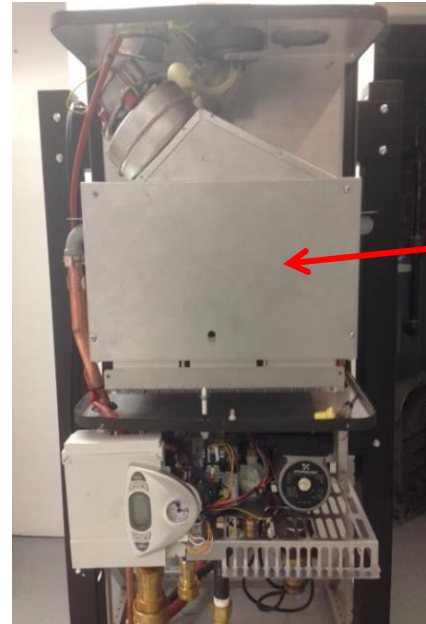

Combustion
Chamber Inner
Cover

Step 2

LP Conversion

Step 3

Electrode

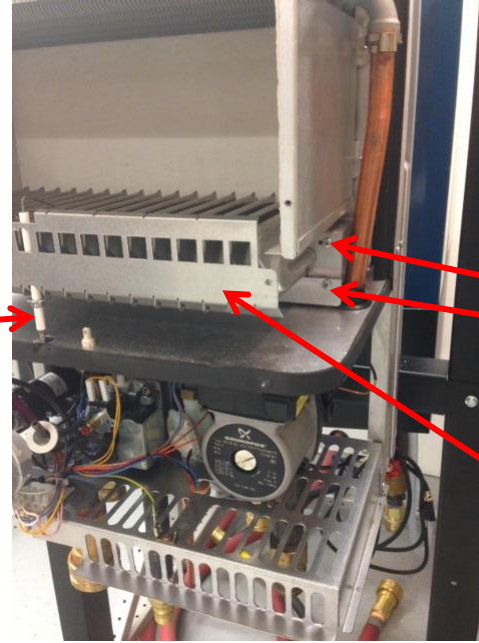

Remove 2 Screws
right side & 2 on
left

Remove
Burner Assy

Step 4

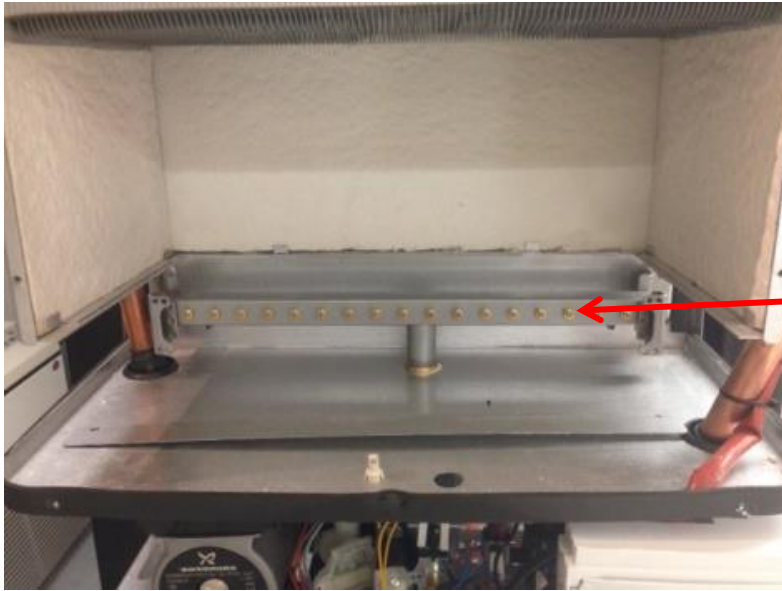

Use 7mm nutdriver/socket to change orifice's

Quantity of Orifice's
CCB150 = 17
CHB100 = 11
CHB130 = 15
NG Orifice size 1.35mm
LP Orifice size 0.85mm

Control Panel – All Models

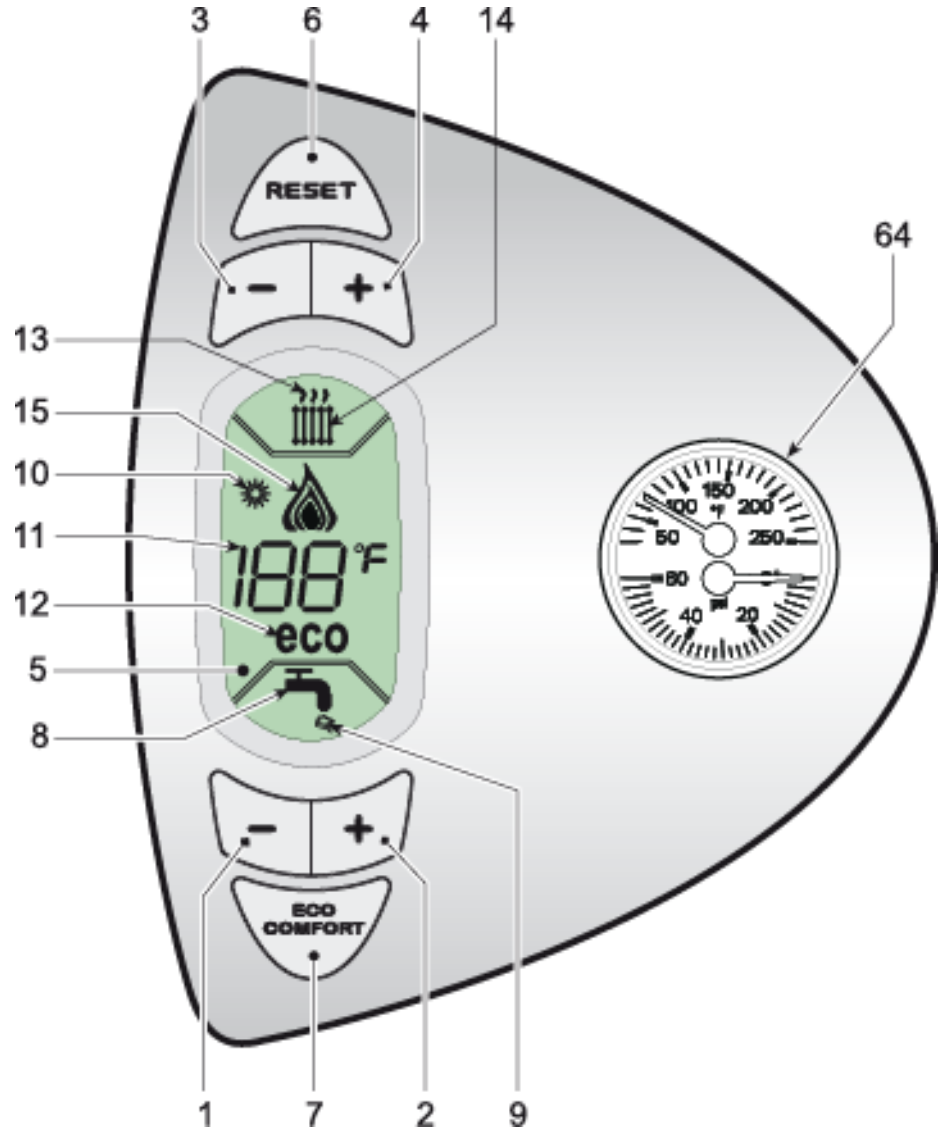

- 1 = DHW temperature setting decrease button
- 2 = DHW temperature setting increase button
- 3 = Heating system temperature setting decrease button
- 4 = Heating system temperature setting increase button
- 5 = Display
- 6 = Summer/Winter mode selection - Reset button
- 7 = Unit On/Off - Economy/Comfort mode selection button
- 8 = DHW symbol
- 9 = DHW mode
- 10 = Summer mode
- 11 = Multifunction
- 12 = Eco (Economy) mode
- 13 = Heating
- 14 = Heating symbol
- 15 = Burner On and actual power
- 64 = C.h. temperature pressure gauges

On/Off Mode – All Models

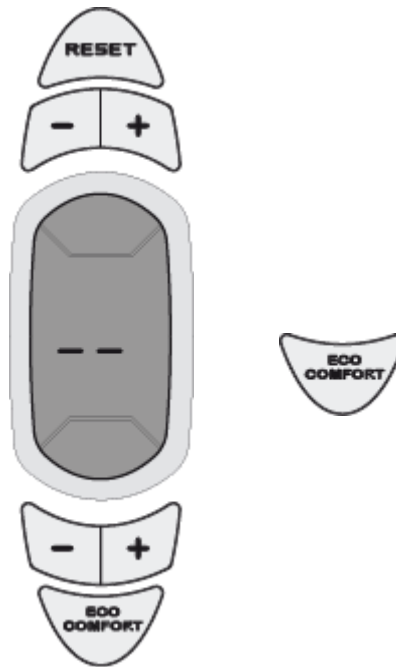

By pressing the 'ON-OFF' (ECO/COMFORT Button), the boiler switches on and off.
In the off mode the antifrost protection and pump antisticking protection will still be active.
3 way valve is in middle position.

Standby Mode

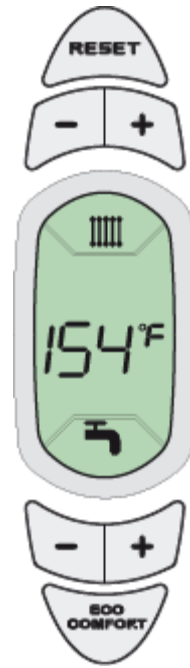

In Standby Mode the boiler will display the temperature.

The boiler is ready to accept a call for heating from the room thermostat, Indirect tank sensor (Optional), or upon flow of potable water (Combi only)

FH Mode – All Models

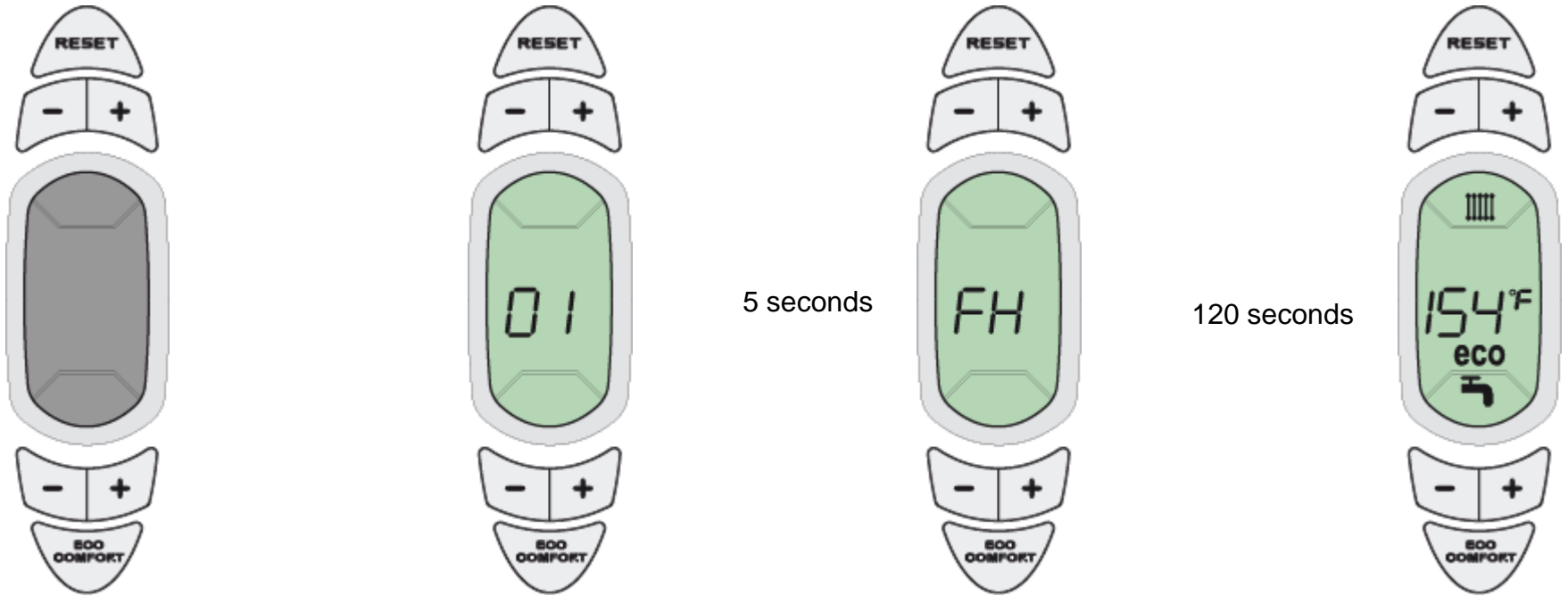

- Whenever the boiler is powered on or after an F37 Fault (Water Pressure error) the boiler will enter the FH Mode (Boiler pump runs to purge air as indicated below).
- FH Mode lasts for 120 seconds during which time the fan is off; the pump is on and off every 5 seconds; and the 3-way valve changes position every 30 seconds.
- During the first 5 seconds of FH mode software release version is shown.

FH Mode – All Models



To skip FH Mode:

- Turn power off to the boiler.
- Depress ECO/Comfort button and hold
- Restore Power
- Release ECO/Comfort button when display comes on

ECO/COMFORT Mode – CCB 150

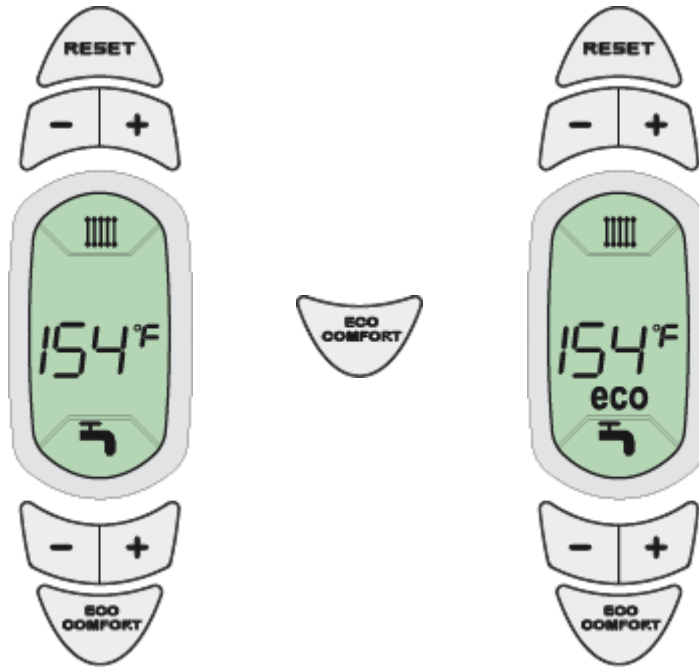

Comfort Mode:

Boiler will maintain the temperature of the brazed plate heat exchanger as follows:

- < 104°F Boiler On
- > 140°F Boiler Off

To activate the ECO mode, press the ECO/Comfort button. ECO appears on the display. In ECO mode, preheating of the DHW heat exchanger is not performed.

To activate the Comfort mode, press the ECO/Comfort button. ECO disappears and the boiler will maintain the brazed plate heat exchanger for faster delivery of hot water.

Summer Winter Mode – All Models

Summer / Winter Switch over

NOTICE

Activating this button will keep your boiler from operating. Verify that boiler is not required to run Domestic Hot Water (DHW) needs.

Press the button for 2 seconds.

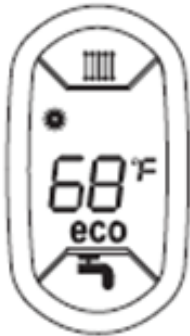

Display will activate Summer symbol (see item 10 on the control panel display). If optional tank sensor is installed boiler will activate DHW circuit only. Antifreeze system stays on. To turn off Summer mode, press button again for 2 seconds.

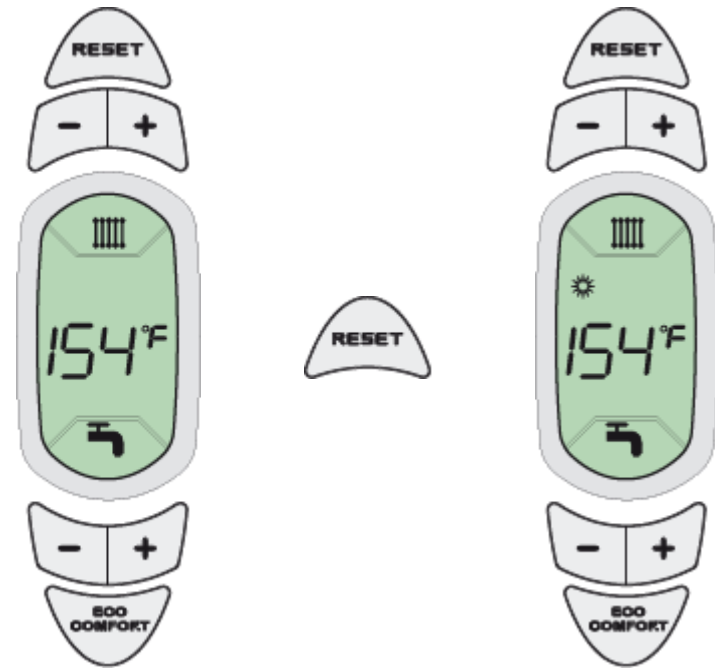

Antifrost – All Models

When the temperature sensor is lower than 41 °F:

- The 2-way valve will shift to the middle position
- The pump will start and the burner will operate at minimum power.
- The burner will shut off when the temperature sensor reaches 59 °F.
- The pump will complete post circulation.

DHW Mode – CCB 150

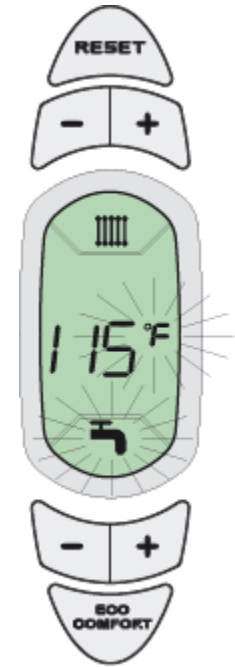

In DHW mode the tap icon will activate showing water flow. Use the DHW buttons to increase/decrease the water temperature.

When the burner is operating the display will indicate the boiler is at low-medium-high power by the size of the flame displayed:



Optional Outdoor Sensor Temperature All Models

All models may have an optional Outdoor Temperature Sensor installed.

The Outdoor Sensor will allow the boiler to operate at a reduced water temperature depending on outside temperature.

This will result in significant fuel savings.



Optional Outdoor Sensor Temperature

All Models

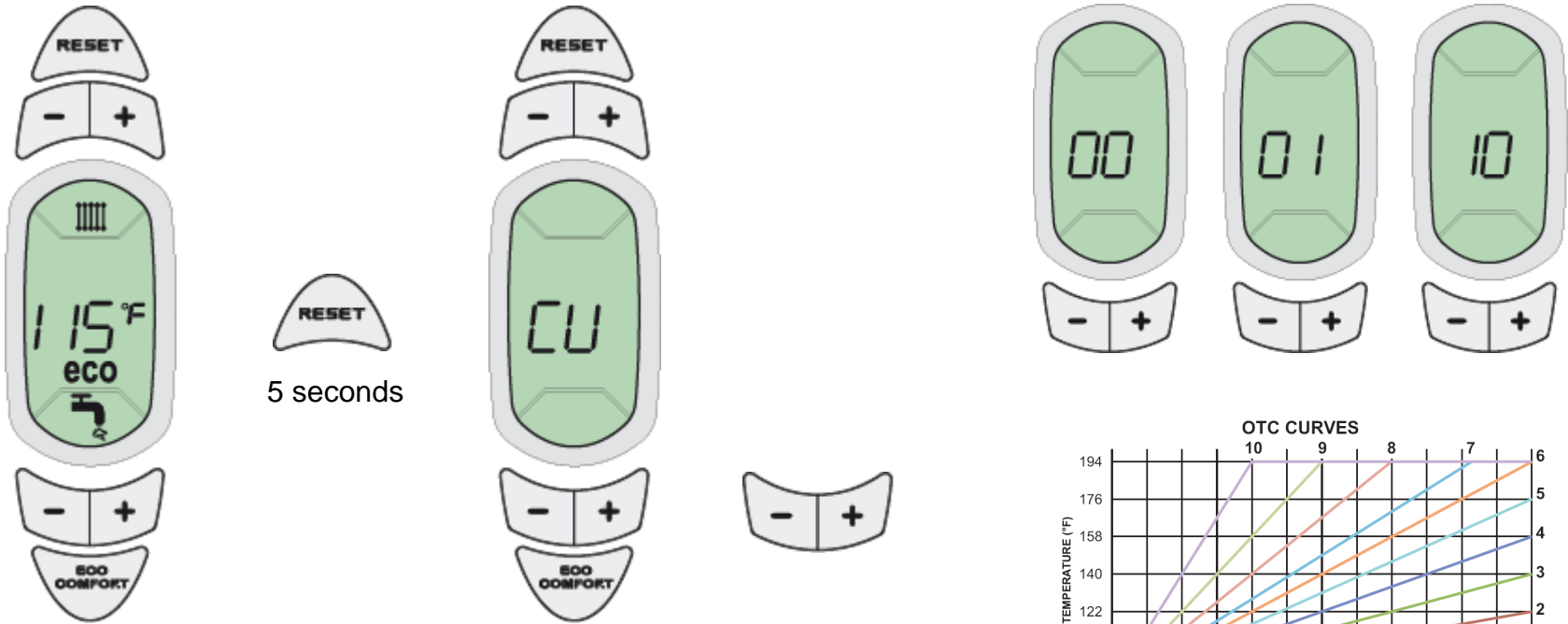

When the optional Outdoor Air Sensor is connected, press the reset button for 5 seconds. CU will appear flashing. Use the DHW buttons to set the curve. Entering '0' means there is no outside air.

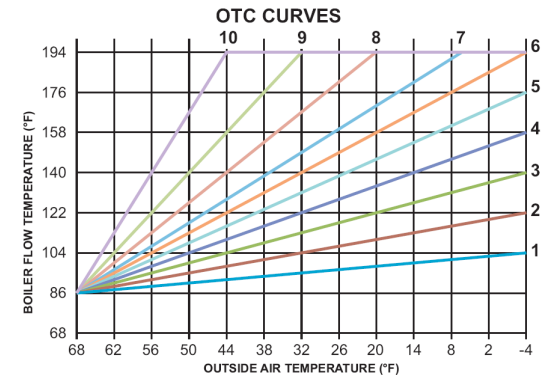

OTC Curves

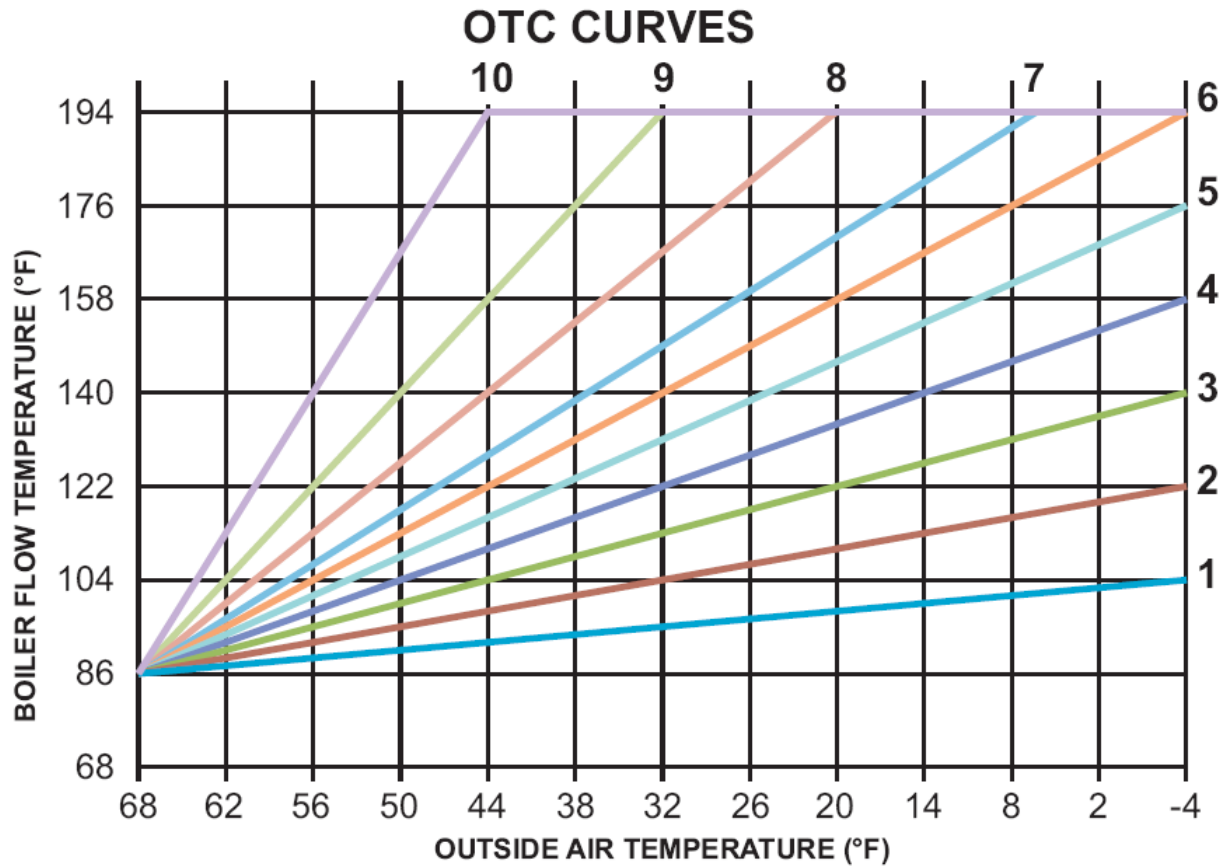

Parallel Compensation Curve Shift

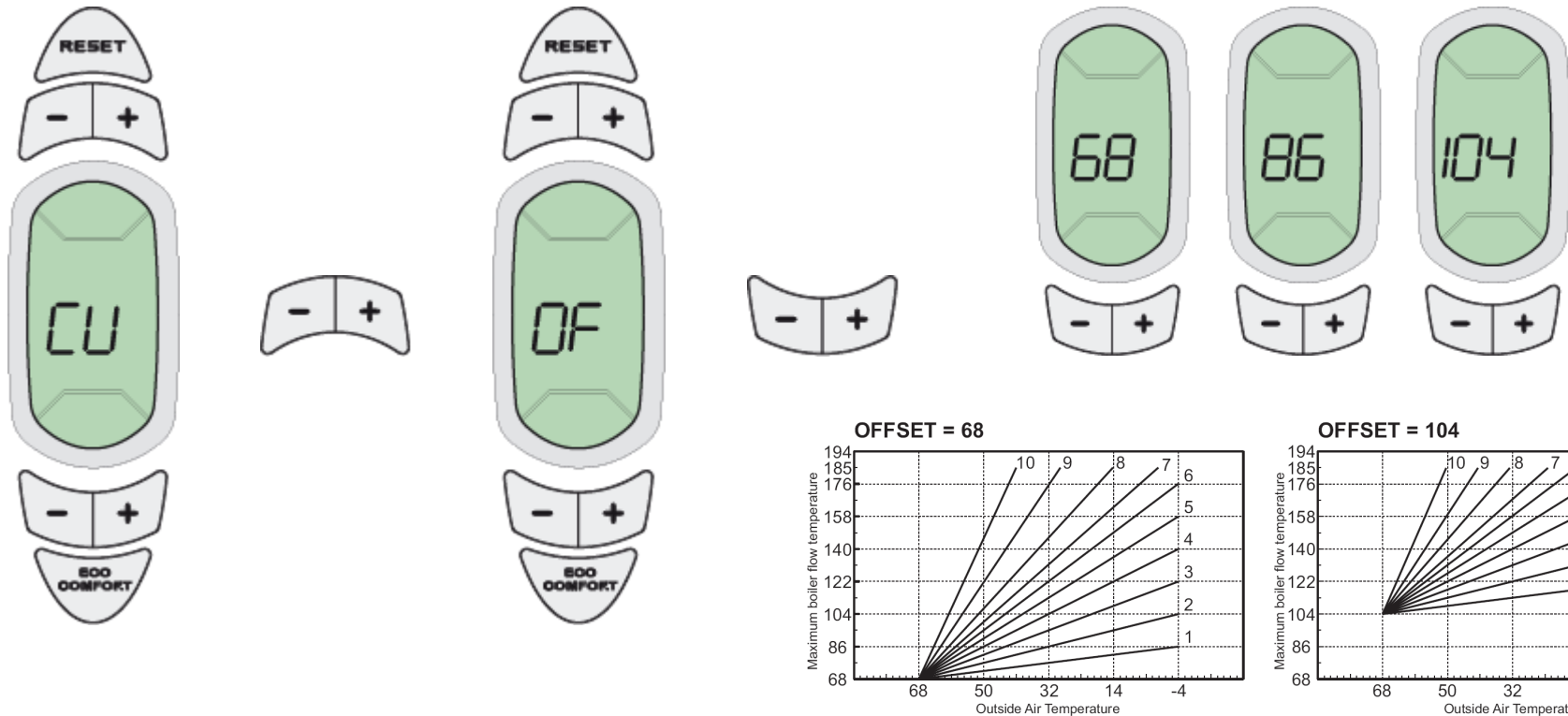

After choosing curve press CH button to enter in parallel compensation curve menu.

Press DHW button to adjust from 68°F to 104°F (20-40°C).

Parallel Compensation Curve Shift

OFFSET = 68

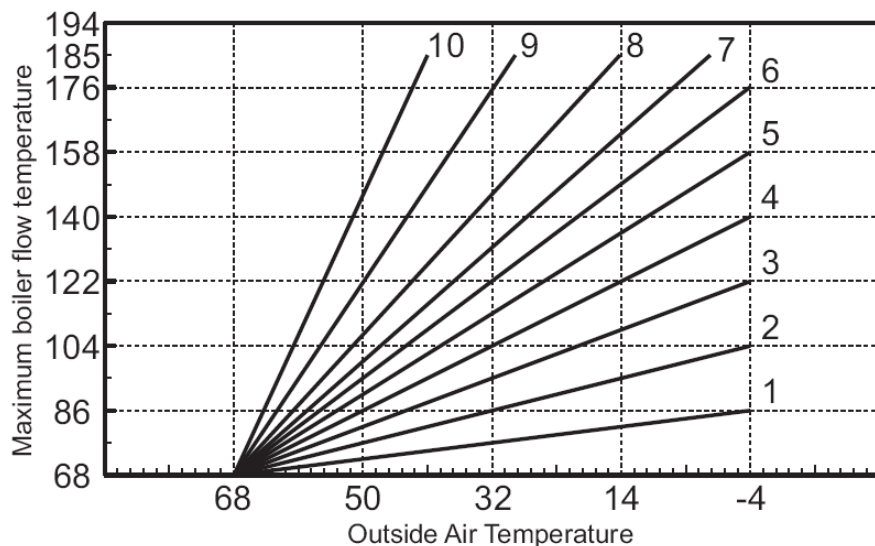

OFFSET = 104

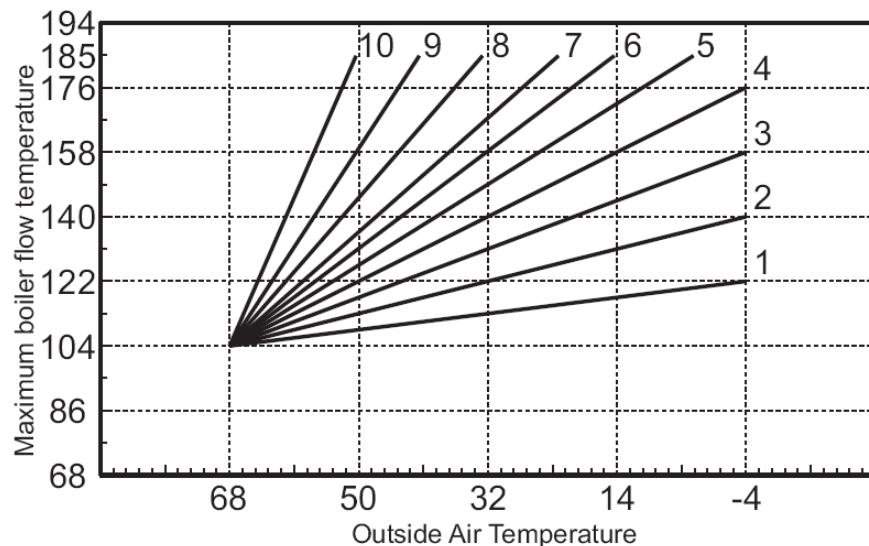

Note: See I.O.M. for detailed curve information

Outdoor Temperature Sensor – All Models

Outdoor sensor: NTC 10K @ 77°C

°F	R(Ω)	°F	R(Ω)	°F	R(Ω)	°F	R(Ω)
-4	96125	32	32505	68	12483	104	5332
-2.2	90743	33.8	30898	69.8	11935	105.8	5123
-0.4	85694	35.6	29381	71.6	11414	107.6	4923
1.4	80959	37.4	27946	73.4	10919	109.4	4732
3.2	76510	39.2	26590	75.2	10447	111.2	4549
5	72335	41	25308	77	9999	113	4374
6.8	68412	42.8	24094	78.8	9572	114.8	4207
8.6	64725	44.6	22946	80.6	9166	116.6	4047
10.4	61259	46.4	21859	82.4	8779	118.4	3894
12.2	57999	48.2	20829	84.2	8411	120.2	3748
14	54932	50	19854	86	8060	122	3608
15.8	52045	51.8	18930	87.8	7726	123.8	3473
17.6	49327	53.6	18054	89.6	7407	125.6	3345
19.4	46767	55.4	17223	91.4	7103	127.4	3222
21.2	44354	57.2	16436	93.2	6813	129.2	3104
23	42080	59	15689	95	6537	131	2991
24.8	39936	60.8	14980	96.8	6273	132.8	2882
26.6	37914	62.6	14306	98.6	6021	134.6	2778
28.4	36006	64.4	13667	100.4	5781	136.4	2679
30.2	34205	66.2	13060	102.2	5551	138.2	2583

Test Mode – All Models

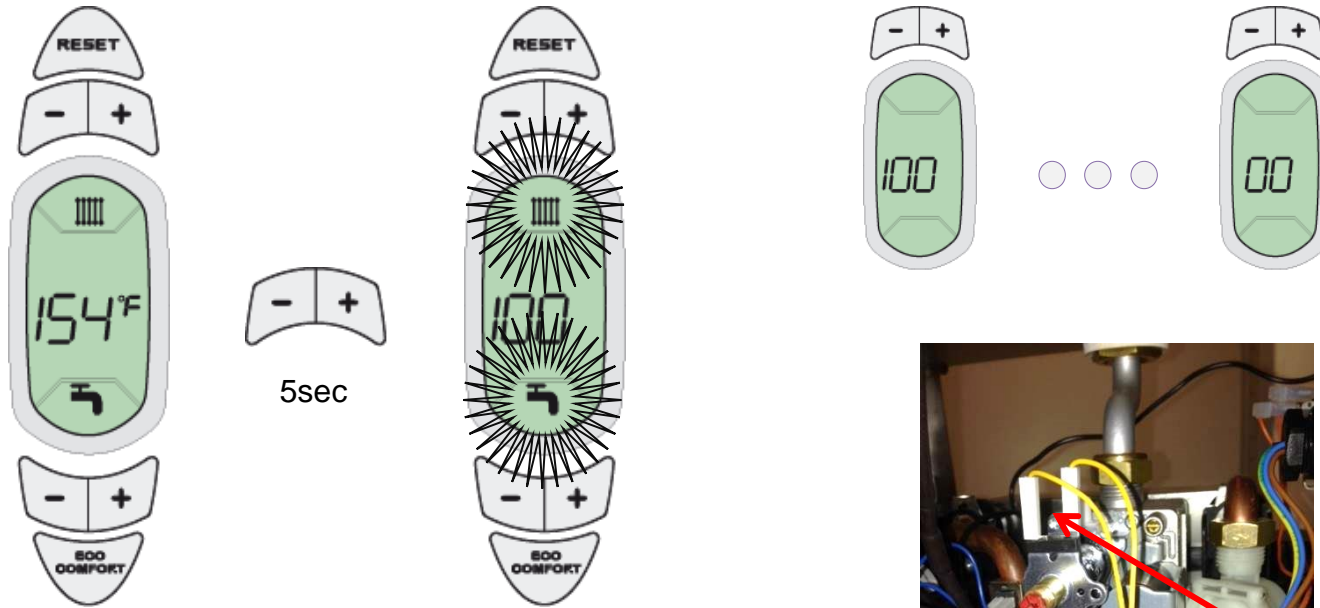

To perform combustion test you must enter Test Mode.

Before starting Test Mode:

- Connect a manometer to gas valve manifold pressure port

Press the CH +/- buttons together for 5 seconds.

• 3 way valve is in CH position and burner is forced at 100%. Boiler automatically exits test mode after 15 minutes or to exit test mode manually: press the CH +/- buttons together for 5 seconds.

• With CH +/- buttons you can adjust max power (from 0 to 100%).



Tip: When locked in high fire you can put boiler into Low fire by disconnecting either ModuReg wire

Service Menu

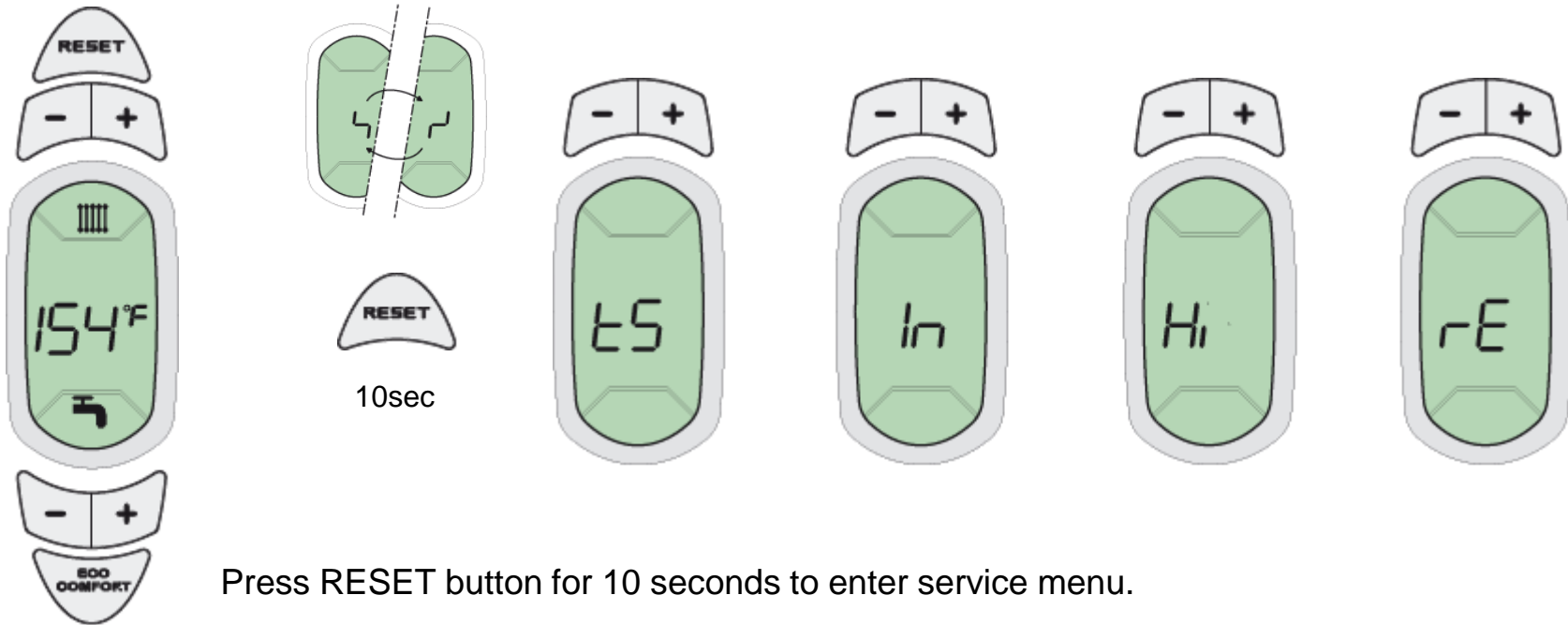

Press RESET button for 10 seconds to enter service menu.

To move through the menu press CH button. To enter the menu press RESET one (1) time.

tS – In – Hi – rE

1. tS (Technical Settings) Menu is the parameter menu.
2. In (Information) Menu will give you the sensor values
3. Hi (History) is the fault history menu.
4. rE (Reset) menu allows you to reset all the faults by pressing the ECO/COMFORT button for three (3) seconds.

tS Menu

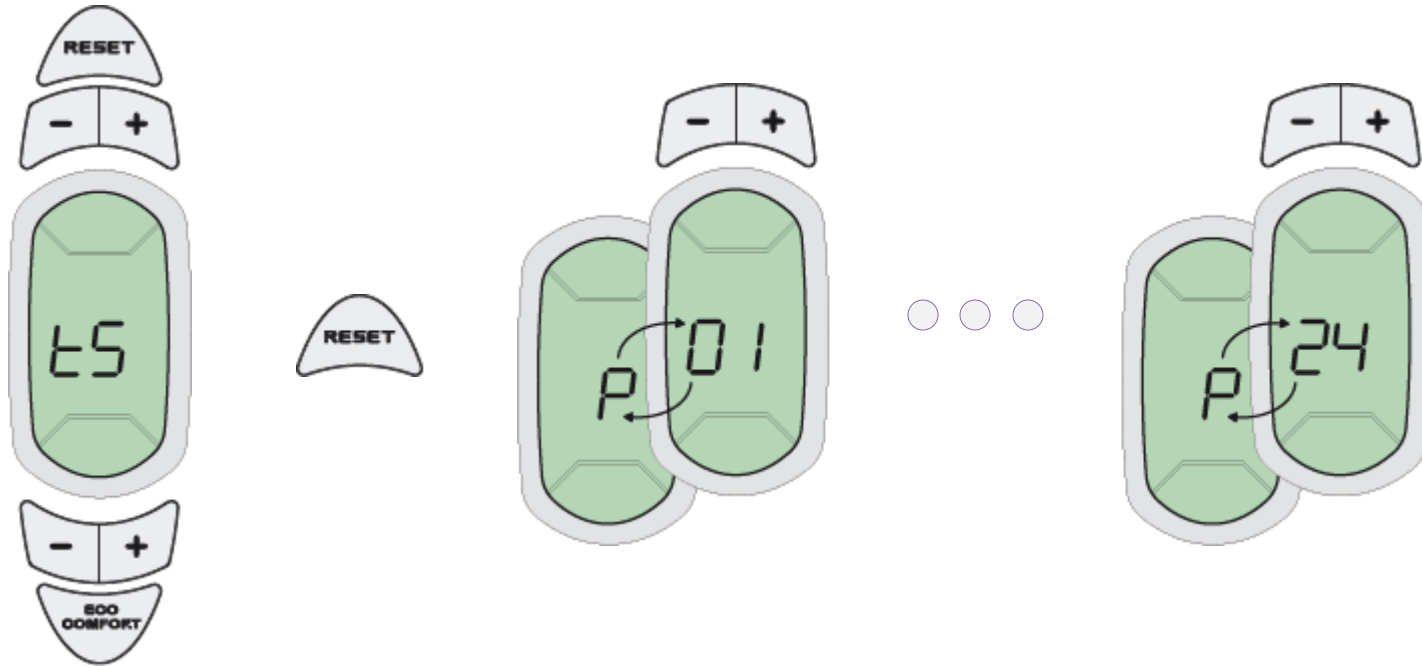

To enter tS press reset one (1) time

Use the CH +/- buttons to scroll parameters

tS Menu

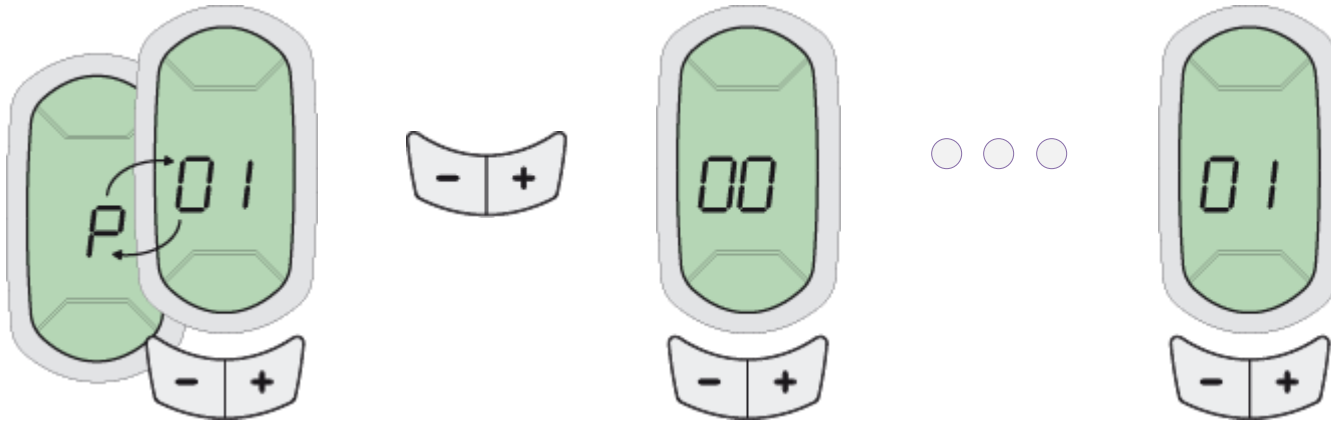

Use the DHW +/- buttons to change values

tS Menu – CCB 150

Par.	Description	Default
P01	Gas type selection (0= Nat, 1= Lpg)	0
P02	DHW configuration (1= Instantaneous, 2= Storage)	1
P03	Absolute minimum output (%)	0
P04	Ignition level (%)	60
P05	Water pressure protection (0=Switch, 1=Sensor)	0
P06	CH slope control (°C/min)	5
P07	CH pump over-run time (Min)	6
P08	CH OFF time (Min)	2
P09	CH maximum output (%)	100
P10	CH pump continuous selection (0=over-run, 1=cont.)	
P11	CH supply for CH pump over-run OFF (°C) - DHW config. 1 CH supply for CH pump over-run OFF (°C) - DHW config. 2	33 20
P12	CH set point limit HIGH (°C)	185°F
P13	DHW pump over-run time (Sec)	30
P14	DHW OFF time (Sec)	120
P15	DHW maximum output (%)	100
P16	DHW set point limit HIGH (°C) - DHW config.1 DHW set point limit HIGH (°C) - DHW config 2	131°F
P17	DHW Comfort switch on point - DHW config.1 DHW Comfort Hysteresis (°C) - DHW config. 2	2°F
P18	DHW Comfort temperature difference (°C) - DHW config.1	20
	CH supply over-temp_burnerON (°C) - DHW config.2	80

Information Menu



Press RESET to enter

Use CH +/- button to scroll parameter

Use DHW +/- button to display value

t01
CH Supply sensor 1 Temperature (°F)
t02
CDHW sensor 1 Temperature (°F)
t03
DHW sensor 2 Temperature (°F)
t04
Outdoor sensor Temperature (°F)
t05
CH Supply sensor2 Temperature (°F)
L06
Actual load of the burner (%)
F07
Actual water flow rate (/10 l/min)
P08
Actual water pressure (psi)
F09
Actual Flame Current (uA)
P10
Actual air pressure (Pa)
P11
Actual air pressure setpoint (Pa)

Fault History Menu

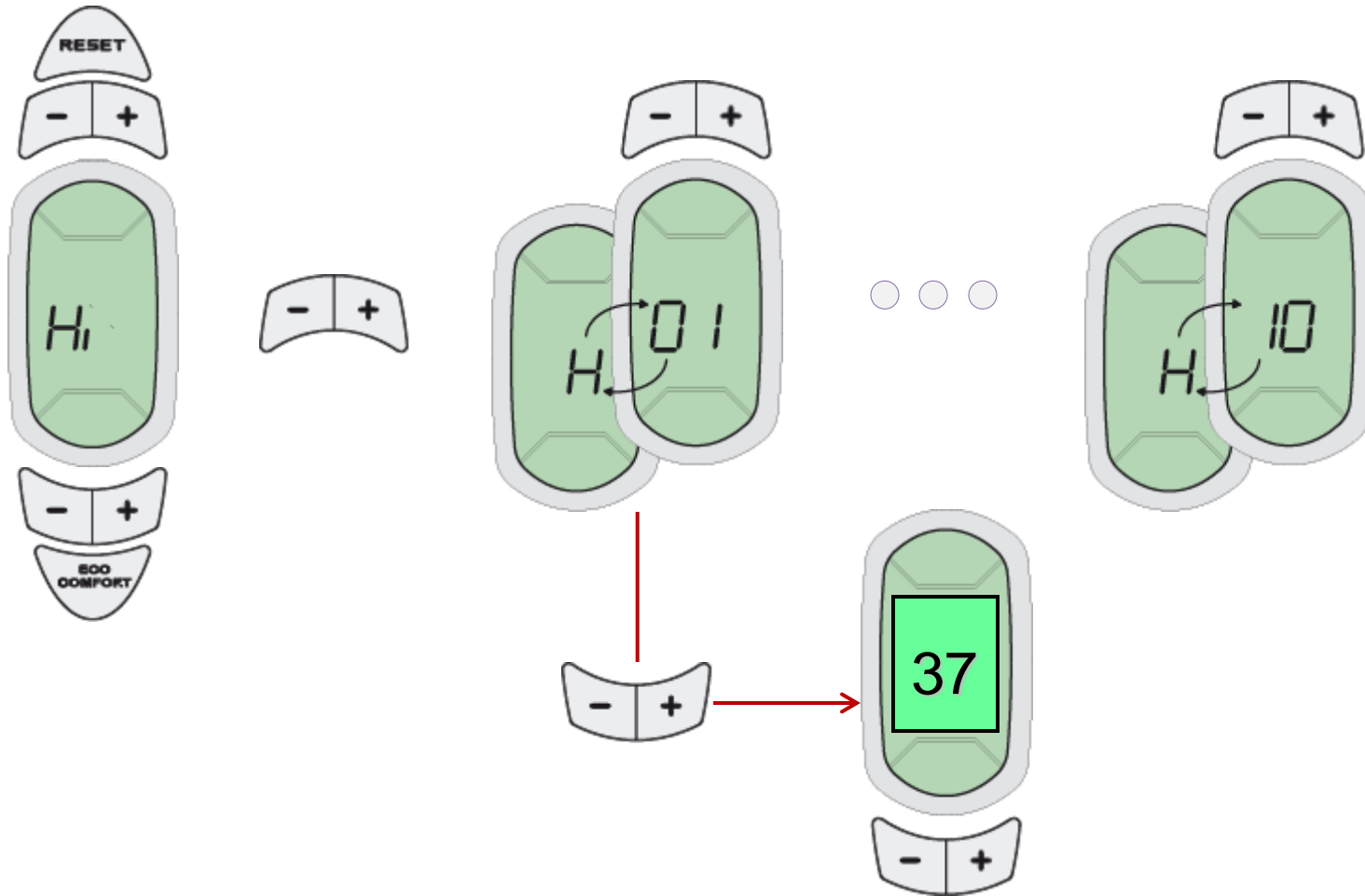

Press CH button to scroll fault – press DHW button to display fault:

Fault H01 is the last fault

Example: F37 – CH water low pressure

Fault

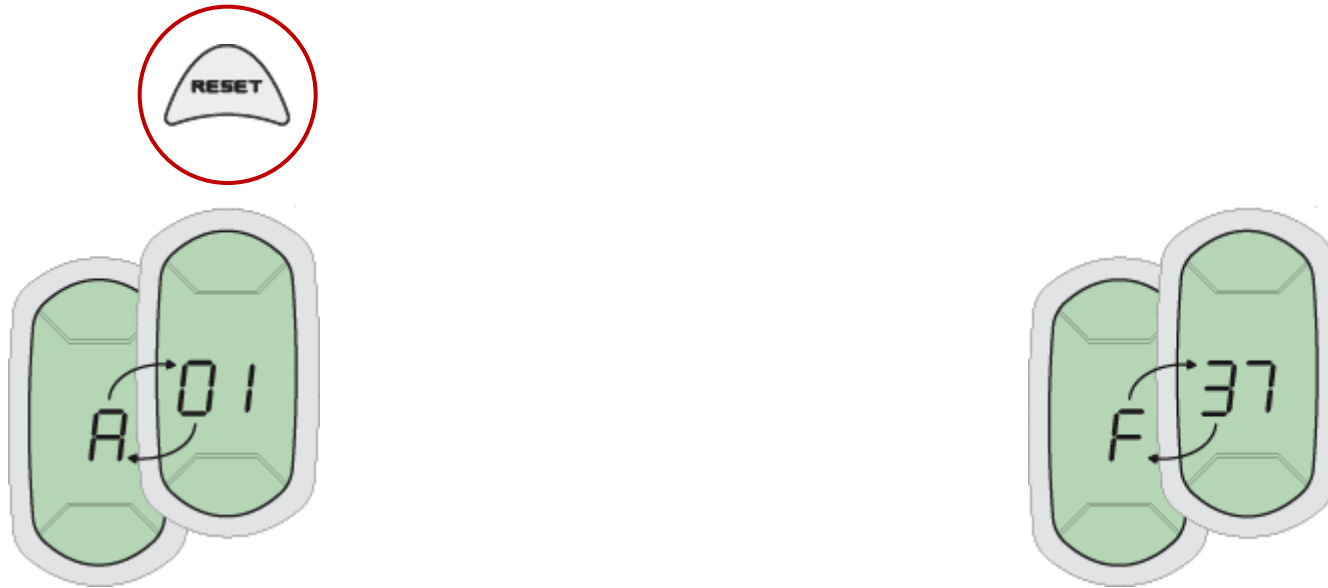

An 'A' Fault: Must be reset with RESET button

An 'F' Fault: The number of the fault appears. Boiler will automatically resume operation if fault clears.

Fault List

A= Hard lockout manual reset required /F is auto reset when condition clears

Fault code	Fault	Possible cause	Resolution
A01	No burner ignition	No gas	Check the regular gas flow to the boiler and that the air has been eliminated from the pipes
		Ignition/detection electrode fault	Check the wiring of the electrode and that it is correctly positioned and free of any deposits
		Faulty gas valve	Check the gas valve and replace it if necessary
		Ignition power too low	Adjust the ignition power
A02	Flame present signal with burner off	Electrode fault	Check the ionization electrode wiring
		Card fault	Check the card
A03	Overtemperature protection activation	Heating sensor damaged	Check correct heating sensor positioning and operation
		No water circulation in the system	Check the circulating pump
		Air in the system	Vent the system
F05	The air pressure transducer does not receive a sufficient minimum value within 25 seconds	Incorrect air pressure transducer wiring	Check the wiring of the electrode and that it is correctly positioned and free of any deposits
		Flue not correctly sized or obstructed	Check the length of flue and that it is clean
A06	No flame after the ignition stage	Low pressure in the gas system	Check the gas pressure
		Burner minimum pressure setting	Check the pressures
F10	Delivery sensor	Sensor damaged	Check the wiring or replace the sensor
		Wiring shorted	
		Wiring disconnected	
F11	DHW sensor fault	Sensor damaged	Check the wiring or replace the sensor
		Wiring shorted	
		Wiring disconnected	
A15	Air signal protection activation	Fault F05 generated 5 times in the last 15 minutes	See fault F05
F34	Supply voltage under 170V	Electric mains trouble	Check the electrical system
F35	Faulty mains frequency	Electric mains trouble	Check the electrical system
F37	Incorrect system water pressure	pressure too low	Fill the system
		Sensor damaged	Check the sensor

Fault List

A= Hard lockout manual reset required /F is auto reset when condition clears

Fault code	Fault	Possible cause	Resolution
F39	External probe fault	Probe damaged or wiring short circuit	Check the wiring or replace the sensor
		Probe disconnected after activating the sliding temperature	Reconnect the external probe or disable the sliding temperature
A41	Sensor positioning	Delivery sensor detached from the pipe	Check correct heating sensor positioning and operation
F42	Heating sensor fault	Sensor damaged	Replace the sensor
F43	Exchanger protection activation	No system H2O circulation	Check the circulating pump
		Air in the system	Vent the system
A44	DHW sensor disconnected	Sensor disconnected	Check the correct positioning and operation of the DHW sensor
A48	Air signal protection activation	Fault F05 for 150 seconds	See Fault F05
F50	Modulation regulator fault	Wiring disconnected	Check the wiring
F51	Low water cutoff warning	Pressure too low	Fill the system
		Low water cutoff damaged	Check the contact

Configuration Menu

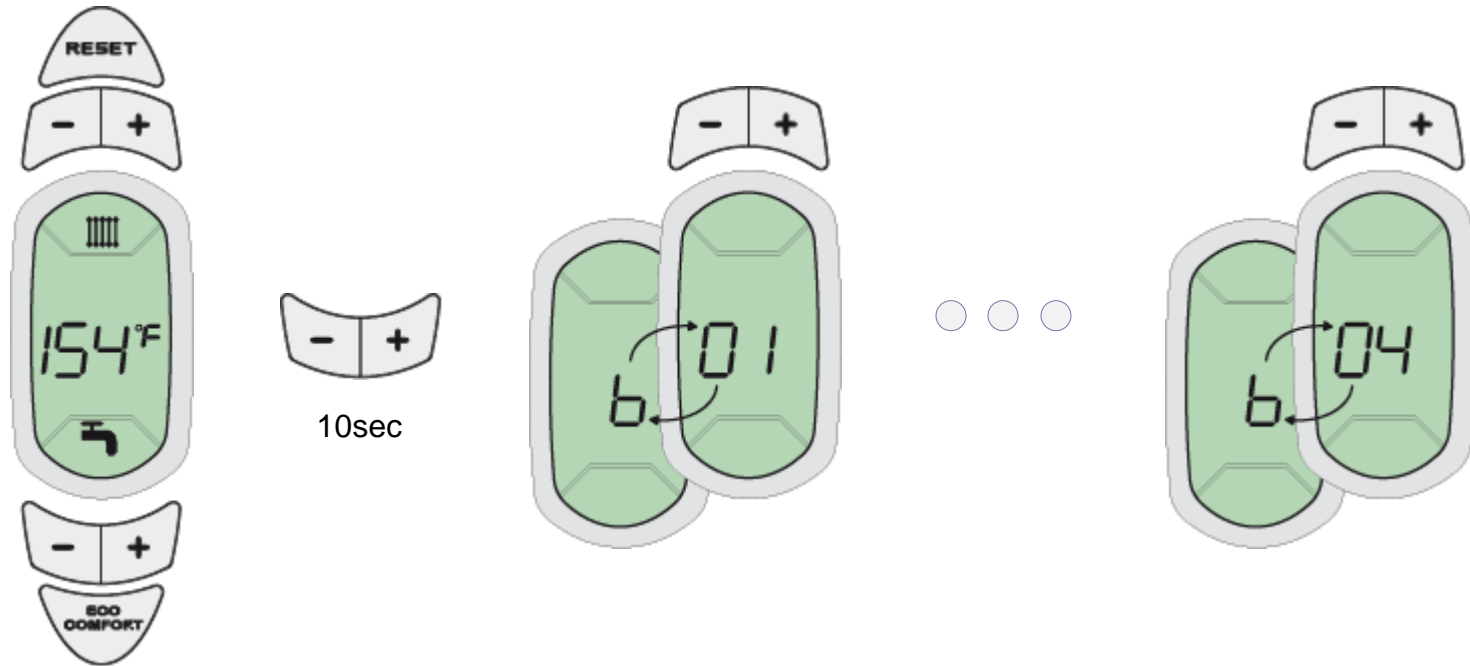

To enter configuration menu press the DHW +/- buttons together for 10 seconds.

Use the CH +/- button to scroll parameters and DHW +/- button to change values.

Configuration Menu

Parameter	Description	Default
b01	Curve selection (0=100mbh, 1=130 mbh, 2=150 mbh)	2
b02	DO NOT CHANGE	0
b03	DO NOT CHANGE	0
b04	DO NOT CHANGE	0

When field replacing a control board you must select the proper model number in b01. Default is 2.

0=CHB-100

1=CHB-130

2= CCB-150

Warranty – All Models

Two Years All Parts

Ten Years On Primary Heat Exchanger

QUESTIONS?

TECHNICAL SERVICE (800) 753-2500