



# Trade Price Book - 815

Innovative. Efficient. Dependable. Dunkirk.

Effective 8/24/15

**Helix VLT**  
Available in 50 to 299 MBH  
Built in Primary/Secondary Piping  
**95% AFUE**



**Helix VX**  
Available in 50 to 200 MBH  
**95% AFUE**



**Q90-100 Series IV**  
Cast Aluminum Gas  
Condensing Boiler  
**90% AFUE**



**DWB**  
Wall-Hung Copper  
Modulating Boiler  
Space Heating-Only  
& Combi Units  
**85% AFUE**



**H<sub>2</sub>O Indirect**  
Stainless Steel  
Indirect Water Heater  
Lifetime Warranty



**Plymouth Steam  
Boiler**  
Cast Iron Gas Boiler  
Low Profile, Built-in  
Draft Diverter  
**UP TO 82.7% AFUE**



**Excelsior EXB**  
3 Pass Cast Iron Oil Boiler  
**UP TO 86.5% AFUE**



**DXL**  
Cast Iron Gas Boiler  
Low Profile, Built-In Draft  
Diverter & LWCO  
**UP TO 83.5% AFUE**



**Customer Service  
Technical Support**  
Phone: 800-325-5479  
Fax: 315-724-9319/866-432-7329  
www.dunkirk.com

**Corporate Sales**  
Phone: 877-386-5475  
Fax: 716-366-4670

**Literature**  
literature@ecrinternational.com



P/N 240005064 815 Rev. A

| <b>TABLE OF CONTENTS</b> |  |
|--------------------------|--|
|--------------------------|--|

|                                                                  |              |
|------------------------------------------------------------------|--------------|
| <b>Contents</b>                                                  | <b>2</b>     |
| <b>Terms &amp; RMA Policy</b>                                    | <b>3-4</b>   |
| <b>Gas Condensing Boilers</b>                                    |              |
| Helix VLT Stainless Steel Wall Hung Modulating Condensing Boiler | <b>5-8</b>   |
| Helix VX Stainless Steel Wall Hung Modulating Condensing Boiler  | <b>9-12</b>  |
| Q90-100 Series IV Cast Aluminum Condensing Boiler                | <b>13-15</b> |
| <b>Gas Modulating Space Heating Only &amp; Combi Boilers</b>     |              |
| DWB Copper Wall Hung Modulating Boiler                           | <b>16-17</b> |
| <b>Gas Cast Iron Boilers</b>                                     |              |
| DXL Series                                                       | <b>18-21</b> |
| XEB II                                                           | <b>22-25</b> |
| WPSB                                                             | <b>26-29</b> |
| PSB                                                              | <b>30-31</b> |
| D249 Steam                                                       | <b>32-34</b> |
| <b>Oil Cast Iron Boilers</b>                                     |              |
| Excelsior EXB                                                    | <b>35-40</b> |
| Empire Water II Series II                                        | <b>41-46</b> |
| ESC IV Series                                                    | <b>47-48</b> |
| <b>Indirect Hot Water Heaters</b>                                |              |
| H2O Single Coil Stainless Steel Indirect Hot Water Heater        | <b>49-50</b> |
| H2O Dual Coil Stainless Steel Indirect Hot Water Heater          | <b>51-52</b> |
| H2O Storage Tanks                                                | <b>53-54</b> |
| H2O Buffer Tanks                                                 | <b>55-56</b> |
| Hotline Indirect Water Heaters                                   | <b>57</b>    |

**TERMS & CONDITIONS OF SALE - GENERAL TERMS**

**PRICES & SPECIFICATIONS:** All pricing and specifications subject to change without notice. The prices herein supersede all prior quotations.

**PAYMENT TERMS:** Net 30 Days

**ORDERS:** Orders will be accepted on the basis of prices in effect at the time the order is received. No order or contract will become an obligation on our part until accepted by the General Sales Department. ECR International shall not be liable for any delay or failure in the delivery or shipment of goods due to any cause or causes beyond its control.

**TAXES:** Add to the prices and terms quoted any manufacturers' or sales tax payable on the transaction under any effective statute.

**SHIPMENT**

**TRUCK LOADS:** \$40,000 Net Order Value - Freight Prepaid. Indirect Water Heaters and Commercial Boiler lines can be added to any residential order for freight purposes. Authorized Distributors can combine Argo, Airco, Dunkirk, EMI, Olsen, Pennco and Utica and on one purchase order to earn free freight.

Stop off charges of \$150 will apply to stop off locations within 100 miles of final destination. Please call for pricing for stop off special handling for a location further than 100 miles or for special handling pricing for services such as lift gate, unloading assistance, etc.

**LESS THAN TRUCKLOAD SHIPMENT: F.O.B. ECR INTERNATIONAL - FACTORY OR WAREHOUSE****ORDER INFORMATION CHECKLIST**

The following information must be included on equipment or parts orders to insure proper shipment & invoicing:

- 1) Purchase Order Number
- 2) Bill To Address
- 3) Ship To Address
- 4) Method of Shipment (i.e. - trailer load, UPS, etc.)
- 5) Requested Ship Date
- 6) Special Instructions (i.e. - "Carrier to call...")
- 7) Pricing
- 8) Product Description (i.e. - Model, Size, Series, etc.)
- 9) Fuel Characteristics (i.e. Oil, Natural Gas, Propane)
- 10) Electrical Characteristics (i.e. - Operating Voltage, Cycles, Phases, etc.)
- 11) Non-Standard Equipment (Indicate "Optional" when substituted for standard equipment at extra cost listed. added to standard equipment).
- 12) Kits or Parts (Orders for kits or parts must indicate equipment size and series).
- 13) Send orders to:

**E-Mail: [ecrorderentry@ecrinternational.com](mailto:ecrorderentry@ecrinternational.com)**

**Fax: 315-724-9319**

- 14) Please note the following Remit To Address:

**ECR International, Inc.  
P.O. Box 8000 Department 039  
Buffalo, NY 14267**

Continued on Next Page

**TERMS & CONDITIONS OF SALE - GENERAL TERMS CONTINUED**  
**U.S. DISTRIBUTOR - RETURN MATERIAL POLICY - EFFECTIVE 8/18/2014**

guidelines to help you in the unlikely event that you will need to return merchandise purchased from us. These guidelines have been developed after carefully reviewing common industry practice. We trust that you find them fair and easy to follow.

**Prior Approval Required** - All returns for exchange, credit, repair service or warranty claim must be approved by ECR and require an RMA number prior to return of the material. A request must be completed via ECR International's online web portal. Please log on to [www.ecrcustomerportal.com](http://www.ecrcustomerportal.com) (hyperlink below) to complete your request for return. If you do not already have access to the customer web portal please contact ECR Customer Service at 1-800-325-5479 to be set-up.

**Eligibility** - An RMA Request must be received within 60 days from the date of invoice for returns of New & Unused product in original packaging. A restocking fee of 15% will be charged for all new and unused returns that are approved for return. Special Order Products (items not offered as standard in ECR trade price book) are not eligible for return as new and unused product. Request for Warranty Returns must be made within the period covered by the warranty and must fall under the terms and conditions specified in the warranty.

**Repair Service** - Request for repair or rework of product damaged by customer is classified as Repair Service. Repair Service is billed at \$75.00 per hour for labor and net price for parts used in repair/rework. ECR's Return Material (RM) department will evaluate the items returned for repair service. The customer will receive an estimate for the dollar amount, determined by ECR's RM department, required to complete the repairs requested. A Purchase Order (PO) from the customer for that amount will be required before any work is performed.

**RMA Expiration** - Once the RMA number is issued, the product must be returned within 90 days of the RMA date, or the RMA will be canceled. Products approved for return that are received after 90 days from the RMA date will not be accepted.

**Shipping & Packaging** - All returns must have a valid RMA number clearly displayed on the exterior of the package or the package will not be accepted. All returns of new and unused product must be in the original packaging. All returns must be shipped prepaid by the customer unless otherwise directed by ECR as indicated on the RMA Verification. Ship all approved return material to the facility indicated on the approved RMA Request by the date indicated.

**Replacement Product** - If replacement product is desired it must be indicated on the RMA Request. A PO# is required for the replacement shipment and must be indicated on the RMA Request. All replacement products will be invoiced at the time of shipment. ECR will pay the ground freight for all warranty replacements.

**Application of Credit** - Credit for returned product will be applied to the customer's account (less restocking fees for New and Unused returns) only after confirmation of receipt by ECR and inspection of the product. Issuance of a credit for a partial return of product does not relieve the customer from the obligation to remit payment for the merchandise not returned in accordance with the payment terms referenced on the customer's invoice(s). Customer will have the option to have any product that is denied for credit returned at their expense.

<http://www.ecrcustomerportal.com>

**HELIX VLT SERIES**

NATURAL OR PROPANE  
MODULATING CONDENSING  
HOT WATER BOILER

150 psi  
MAWP

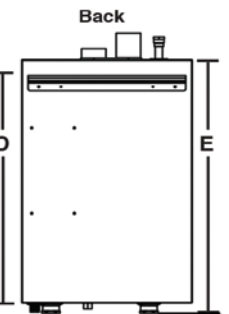
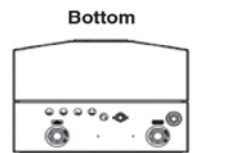
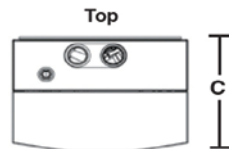
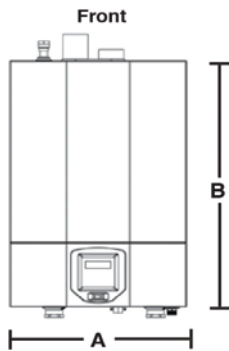

All VLT models have an AFUE of 95% and meet the criteria for 2015 Most Efficient.



**General Information** (See IOM for complete instructions)

| Clearances                                              | Combustible Materials (Required) (1)         |                | Service (2) |             |         |
|---------------------------------------------------------|----------------------------------------------|----------------|-------------|-------------|---------|
|                                                         | (1) Required distances measured from boiler. | Top            | 0" (0 cm)   | 14" (36 cm) |         |
| Left Side                                               |                                              | 0" (0 cm)      | 0" (0 cm)   |             |         |
| Right Side                                              |                                              | 0" (0 cm)      | 0" (0 cm)   |             |         |
| Front                                                   |                                              | 0" (0 cm)      | 6" (16 cm)  |             |         |
| Back                                                    |                                              | 0" (0 cm)      | 0" (0 cm)   |             |         |
| Bottom                                                  |                                              | 0" (0 cm)      | 12" (32 cm) |             |         |
| (2) Service, proper operation clearance recommendation. | Combustion Air/Vent Piping                   | 0" (0 cm)      | 6" (16 cm)  |             |         |
|                                                         | Hot Water Piping                             | See Local Code | 6" (16 cm)  |             |         |
| Combustion Air & Vent Pipe Equivalent Length            | (Schedule 40 PVC)                            |                |             |             |         |
|                                                         | 2" Pipe                                      |                | 3" Pipe     |             | 4" Pipe |
|                                                         | 50                                           | 75/100         | 75/100      | 150/200     | 299     |
| Min. Length                                             | 6 Ft.                                        | 6 Ft.          | 6 Ft.       | 6 Ft.       | 6 Ft.   |
|                                                         | (1.8 m)                                      | (1.8 m)        | (1.8 m)     | (1.8 m)     | (1.8 m) |
| Max. Length                                             | 100 Ft.                                      | 50 Ft.         | 100 Ft.     | 100 Ft.     | 25 Ft.  |
|                                                         | (30.5 m)                                     | (15.2 m)       | (30.5 m)    | (30.5 m)    | (7.7 m) |

| Dimensions        |        |            |
|-------------------|--------|------------|
| Models            | 050    | 150        |
|                   | 075    | 200        |
|                   | 100    | *299       |
| Width "A"         | 20"    | 23"        |
|                   | 508 mm | 584 mm     |
| Height "B"        | 30"    | 40"        |
|                   | 762 mm | 1016 mm    |
| *Depth "C"        | 14"    | 16"/18.3"  |
|                   | 356 mm | 406/465 mm |
| Bracket "D"       | 28"    | 40"        |
|                   | 711 mm | 1016 mm    |
| Ht. w/ Piping "E" | 31"    | 42"        |
|                   | 787 mm | 1092 mm    |

Note: Refer to IOM and vent pipe manufacturer's instructions for equivalent vent lengths and alternate venting materials.

| Connections          | Return/Supply Water                                                             | Gas In   | Cond. Drain |
|----------------------|---------------------------------------------------------------------------------|----------|-------------|
| <b>050/075/100</b>   | 1-1/4" NPT                                                                      | 1/2" NPT | 3/4" NPT    |
| <b>150/200/299</b>   | 1-1/4" NPT                                                                      | 3/4" NPT | 3/4" NPT    |
| <b>Electrical</b>    | 120 Volts AC, 60 hertz, 1 phase, Less than 12 amps (15 amp circuit recommended) |          |             |
| <b>Water Content</b> | 050/075/100 - 1.1 Gallons, 150/200/299 - 1.8 Gallons                            |          |             |

\*299 Dimensions are the same as 150/200 Models **except** for Depth which is 18.3"/465 mm for the 299 model.

| <b>HELIX VLT SERIES CONTINUED</b>                       |                    |                    |                             |                        |                       |                      |                  |                            |
|---------------------------------------------------------|--------------------|--------------------|-----------------------------|------------------------|-----------------------|----------------------|------------------|----------------------------|
| <b>(NATURAL GAS - LESS SYSTEM PUMP)</b>                 |                    |                    |                             |                        |                       |                      |                  |                            |
| <b>BOILER MODEL</b>                                     | <b>ITEM NUMBER</b> | <b>TRADE PRICE</b> | <b>INPUT (MBH) MAX/ MIN</b> | <b>HTG. CAP. (MBH)</b> | <b>AHRI NET (MBH)</b> | <b>AFUE RATING %</b> | <b>FLUE DIA.</b> | <b>BLR./ SHP WGT. LBS.</b> |
| DKVLT-50                                                | DKVLTA050NA0AAA    | \$4,420            | 50/10                       | 46                     | 40                    | 95                   | 2"               | 91/111                     |
| DKVLT-75                                                | DKVLTA075NA0AAA    | \$4,485            | 75/15                       | 69                     | 60                    | 95                   | 2" or 3"         | 91/111                     |
| DKVLT-100                                               | DKVLTA100NA0AAA    | \$4,664            | 100/20                      | 91                     | 79                    | 95                   | 2" or 3"         | 91/111                     |
| DKVLT-150                                               | DKVLTA150NA0AAA    | \$5,625            | 150/30                      | 139                    | 121                   | 95                   | 3"               | 157/182                    |
| DKVLT-200                                               | DKVLTA200NA0AAA    | \$6,032            | 200/40                      | 185                    | 161                   | 95                   | 3"               | 157/182                    |
| DKVLT-299                                               | DKVLTA299NA0AAA    | \$8,840            | 299/60                      | 273                    | 239                   | 95                   | 3" or 4"         | 195/225                    |
| <b>(NATURAL GAS - LESS SYSTEM PUMP - HIGH ALTITUDE)</b> |                    |                    |                             |                        |                       |                      |                  |                            |
| <b>BOILER MODEL</b>                                     | <b>ITEM NUMBER</b> | <b>TRADE PRICE</b> | <b>INPUT (MBH) MAX/ MIN</b> | <b>HTG. CAP. (MBH)</b> | <b>AHRI NET (MBH)</b> | <b>AFUE RATING %</b> | <b>FLUE DIA.</b> | <b>BLR./ SHP WGT. LBS.</b> |
| DKVLT-50                                                | DKVLTA050NA0BAA    | \$4,420            | 50/10                       | 46                     | 40                    | 95                   | 2"               | 91/111                     |
| DKVLT-75                                                | DKVLTA075NA0BAA    | \$4,485            | 75/15                       | 69                     | 60                    | 95                   | 2" or 3"         | 91/111                     |
| DKVLT-100                                               | DKVLTA100NA0BAA    | \$4,664            | 100/20                      | 91                     | 79                    | 95                   | 2" or 3"         | 91/111                     |
| DKVLT-150                                               | DKVLTA150NA0BAA    | \$5,625            | 150/30                      | 139                    | 121                   | 95                   | 3"               | 157/182                    |
| DKVLT-200                                               | DKVLTA200NA0BAA    | \$6,032            | 200/40                      | 185                    | 161                   | 95                   | 3"               | 157/182                    |
| DKVLT-299                                               | DKVLTA299NA0BAA    | \$8,840            | 299/60                      | 273                    | 239                   | 95                   | 3" or 4"         | 195/225                    |
| <b>(NATURAL GAS - WITH TACO SYSTEM PUMP)</b>            |                    |                    |                             |                        |                       |                      |                  |                            |
| <b>BOILER MODEL</b>                                     | <b>ITEM NUMBER</b> | <b>TRADE PRICE</b> | <b>INPUT (MBH) MAX/ MIN</b> | <b>HTG. CAP. (MBH)</b> | <b>AHRI NET (MBH)</b> | <b>AFUE RATING %</b> | <b>FLUE DIA.</b> | <b>BLR./ SHP WGT. LBS.</b> |
| DKVLT-50                                                | DKVLTA050NA1AAA    | \$4,564            | 50/10                       | 46                     | 40                    | 95                   | 2"               | 91/111                     |
| DKVLT-75                                                | DKVLTA075NA1AAA    | \$4,629            | 75/15                       | 69                     | 60                    | 95                   | 2" or 3"         | 91/111                     |
| DKVLT-100                                               | DKVLTA100NA1AAA    | \$4,808            | 100/20                      | 91                     | 79                    | 95                   | 2" or 3"         | 91/111                     |
| DKVLT-150                                               | DKVLTA150NA1AAA    | \$5,769            | 150/30                      | 139                    | 121                   | 95                   | 3"               | 157/182                    |
| DKVLT-200                                               | DKVLTA200NA1AAA    | \$6,176            | 200/40                      | 185                    | 161                   | 95                   | 3"               | 157/182                    |

| <b>HELIX VLT SERIES CONTINUED</b>                                |                    |                    |                             |                        |                       |                      |                  |                            |
|------------------------------------------------------------------|--------------------|--------------------|-----------------------------|------------------------|-----------------------|----------------------|------------------|----------------------------|
| <b>(NATURAL GAS - WITH TACO SYSTEM PUMP - HIGH ALTITUDE)</b>     |                    |                    |                             |                        |                       |                      |                  |                            |
| <b>BOILER MODEL</b>                                              | <b>ITEM NUMBER</b> | <b>TRADE PRICE</b> | <b>INPUT (MBH) MAX/ MIN</b> | <b>HTG. CAP. (MBH)</b> | <b>AHRI NET (MBH)</b> | <b>AFUE RATING %</b> | <b>FLUE DIA.</b> | <b>BLR./ SHP WGT. LBS.</b> |
| DKVLT-50                                                         | DKVLTA050NA1BAA    | \$4,564            | 50/10                       | 46                     | 40                    | 95                   | 2"               | 91/111                     |
| DKVLT-75                                                         | DKVLTA075NA1BAA    | \$4,629            | 75/15                       | 69                     | 60                    | 95                   | 2" or 3"         | 91/111                     |
| DKVLT-100                                                        | DKVLTA100NA1BAA    | \$4,808            | 100/20                      | 91                     | 79                    | 95                   | 2" or 3"         | 91/111                     |
| DKVLT-150                                                        | DKVLTA150NA1BAA    | \$5,769            | 150/30                      | 139                    | 121                   | 95                   | 3"               | 157/182                    |
| DKVLT-200                                                        | DKVLTA200NA1BAA    | \$6,176            | 200/40                      | 185                    | 161                   | 95                   | 3"               | 157/182                    |
| <b>(NATURAL GAS - WITH GRUNDFOS SYSTEM PUMP)</b>                 |                    |                    |                             |                        |                       |                      |                  |                            |
| <b>BOILER MODEL</b>                                              | <b>ITEM NUMBER</b> | <b>TRADE PRICE</b> | <b>INPUT (MBH) MAX/ MIN</b> | <b>HTG. CAP. (MBH)</b> | <b>AHRI NET (MBH)</b> | <b>AFUE RATING %</b> | <b>FLUE DIA.</b> | <b>BLR./ SHP WGT. LBS.</b> |
| DKVLT-50                                                         | DKVLTA050NA3AAA    | \$4,564            | 50/10                       | 46                     | 40                    | 95                   | 2"               | 91/111                     |
| DKVLT-75                                                         | DKVLTA075NA3AAA    | \$4,629            | 75/15                       | 69                     | 60                    | 95                   | 2" or 3"         | 91/111                     |
| DKVLT-100                                                        | DKVLTA100NA3AAA    | \$4,808            | 100/20                      | 91                     | 79                    | 95                   | 2" or 3"         | 91/111                     |
| DKVLT-150                                                        | DKVLTA150NA3AAA    | \$5,769            | 150/30                      | 139                    | 121                   | 95                   | 3"               | 157/182                    |
| DKVLT-200                                                        | DKVLTA200NA3AAA    | \$6,176            | 200/40                      | 185                    | 161                   | 95                   | 3"               | 157/182                    |
| <b>Note: The DKVLT299 is only available less system pump.</b>    |                    |                    |                             |                        |                       |                      |                  |                            |
| <b>(NATURAL GAS - WITH GRUNDFOS SYSTEM PUMP - HIGH ALTITUDE)</b> |                    |                    |                             |                        |                       |                      |                  |                            |
| <b>BOILER MODEL</b>                                              | <b>ITEM NUMBER</b> | <b>TRADE PRICE</b> | <b>INPUT (MBH) MAX/ MIN</b> | <b>HTG. CAP. (MBH)</b> | <b>AHRI NET (MBH)</b> | <b>AFUE RATING %</b> | <b>FLUE DIA.</b> | <b>BLR./ SHP WGT. LBS.</b> |
| DKVLT-50                                                         | DKVLTA050NA3BAA    | \$4,564            | 50/10                       | 46                     | 40                    | 95                   | 2"               | 91/111                     |
| DKVLT-75                                                         | DKVLTA075NA3BAA    | \$4,629            | 75/15                       | 69                     | 60                    | 95                   | 2" or 3"         | 91/111                     |
| DKVLT-100                                                        | DKVLTA100NA3BAA    | \$4,808            | 100/20                      | 91                     | 79                    | 95                   | 2" or 3"         | 91/111                     |
| DKVLT-150                                                        | DKVLTA150NA3BAA    | \$5,769            | 150/30                      | 139                    | 121                   | 95                   | 3"               | 157/182                    |
| DKVLT-200                                                        | DKVLTA200NA3BAA    | \$6,176            | 200/40                      | 185                    | 161                   | 95                   | 3"               | 157/182                    |
| <b>Note: The DKVLT299 is only available less system pump.</b>    |                    |                    |                             |                        |                       |                      |                  |                            |

| <b>HELIX VLT SERIES CONTINUED</b>                                                   |           |              |
|-------------------------------------------------------------------------------------|-----------|--------------|
| <b>VLT SERIES - VENTING OPTIONS/ADDITIONAL EQUIPMENT<br/>(USE PARTS MULTIPLIER)</b> | <b>PN</b> | <b>TRADE</b> |
| 050 NATURAL TO LP AND LP TO NATURAL GAS CONVERSION KIT                              | 550002303 | \$46         |
| 075 NATURAL TO LP AND LP TO NATURAL GAS CONVERSION KIT                              | 550002304 | \$46         |
| 100 NATURAL TO LP AND LP TO NATURAL GAS CONVERSION KIT                              | 550002305 | \$46         |
| 150 NATURAL TO LP AND LP TO NATURAL GAS CONVERSION KIT                              | 550002306 | \$46         |
| 200 NATURAL TO LP AND LP TO NATURAL GAS CONVERSION KIT                              | 550002307 | \$46         |
| 299 NATURAL TO LP AND LP TO NATURAL GAS CONVERSION KIT                              | 550002799 | \$48         |
| 2" CONCENTRIC VENT KIT                                                              | 29570     | \$218        |
| 3" CONCENTRIC VENT KIT                                                              | 29571     | \$218        |
| MULTIPLE BOILER SENSOR KIT                                                          | 550002186 | \$78         |
| FLOOR STAND KIT                                                                     | 240010266 | \$587        |

**VLT SERIES - STANDARD EQUIPMENT****STANDARD EQUIPMENT:**

- Wall Mounted: Bracket included.
- Boiler Control Module: Automatic Low Voltage/Intermittent Direct Spark Ignition/Modulating with a 5:1 combustion turn down ratio. For multiple boiler applications - the control module can stage up to 16 boilers.
- User Display interface: Easy programming with text display. Outdoor Temperature Sensor included.
- Heat Exchanger: High grade 316L/444 Stainless Steel Fin Coil with Flame Sight Glass.
- Built-in Primary/Secondary Manifold Piping and Pump.
- Combustion: Gas Valve with Premix Venturi and Blower, Durable Stainless Steel Mesh Modulating Burner with 5:1 turn down ratio, Direct Spark Igniter, Flame Sensor and LP Conversion Kit included.
- Electrical: Detachable Low Voltage Terminal Strip, High Voltage Junction Box and Transformer.
- Other: Factory installed probe-type Low Water Cut Off with test feature, 30 PSI Safety Relief Valve, Boiler Drain Valve and Condensate Drain with built in trap.



**VX SERIES**

NATURAL OR PROPANE  
MODULATING CONDENSING  
HOT WATER BOILER

150 psi  
MAWP

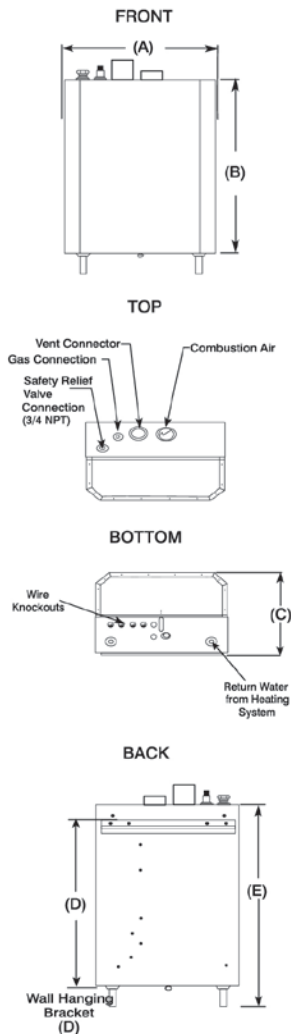

All VX models have an AFUE of 95% and meet the criteria for 2015 Most Efficient.



**General Information** (See IOM for complete instructions)

| Clearances                                           | Combustible Materials (Required) (1)                |                    | Service (2)         |                     |
|------------------------------------------------------|-----------------------------------------------------|--------------------|---------------------|---------------------|
|                                                      | (1) Required distances measured from boiler jacket. | Top                | 0" (0 cm)           | 14" (36 cm)         |
| Left Side                                            |                                                     | 0" (0 cm)          | 0" (0 cm)           |                     |
| Right Side                                           |                                                     | 0" (0 cm)          | 0" (0 cm)           |                     |
| Front                                                |                                                     | 0" (0 cm)          | 6" (16 cm)          |                     |
| Back                                                 |                                                     | 0" (0 cm)          | 0" (0 cm)           |                     |
| Bottom                                               |                                                     | 0" (0 cm)          | 12" (32 cm)         |                     |
| (2) Service, proper operation clearance recommended. | Combustion Air/Vent Piping                          | 0" (0 cm)          | 6" (16 cm)          |                     |
|                                                      | Hot Wat. Piping                                     | See Local Code     | 6" (16 cm)          |                     |
| Combustion Air & Vent Pipe Equiv. Length             | (Schedule 40 PVC)                                   |                    |                     |                     |
|                                                      | 2" Pipe                                             |                    | 3" Pipe             |                     |
|                                                      | 50                                                  | 75/100             | 75/100              | 150/200             |
| Min. Length                                          | 6 Ft.<br>(1.8 m)                                    | 6 Ft.<br>(1.8 m)   | 6 Ft.<br>(1.8 m)    | 6 Ft.<br>(1.8 m)    |
| Max. Length                                          | 100 Ft.<br>(30.5 m)                                 | 50 Ft.<br>(15.2 m) | 100 Ft.<br>(30.5 m) | 100 Ft.<br>(30.5 m) |

**Dimensions**

| Models           | 050    | 150    |
|------------------|--------|--------|
|                  |        | 075    |
|                  | 100    |        |
| Width "A"        | 20"    | 23"    |
|                  | 508 mm | 584 mm |
| Height "B"       | 27.75" | 37.75" |
|                  | 705 mm | 959 mm |
| Depth "C"        | 14.75" | 16.3"  |
|                  | 375 mm | 414 mm |
| Bracket "D"      | 24.41" | 35.6"  |
|                  | 620 mm | 904 mm |
| Ht. w/Piping "E" | 30.75" | 40.75" |
|                  | 781 mm | 104 cm |

**Note: Refer to IOM and vent pipe manufacturer's instructions for equivalent vent lengths and alternate venting materials.**

| Connections          | Return/Supply Water                                                             | Gas In   | Cond. Drain |
|----------------------|---------------------------------------------------------------------------------|----------|-------------|
| <b>050/075/100</b>   | 3/4" Copper stub                                                                | 1/2" NPT | 3/4" NPT    |
| <b>150/200</b>       | 1" Copper stub                                                                  | 3/4" NPT | 3/4" NPT    |
| <b>Electrical</b>    | 120 Volts AC, 60 hertz, 1 phase, Less than 12 amps (15 amp circuit recommended) |          |             |
| <b>Water Content</b> | 050/075/100 - 1.1 Gallons, 150/200 - 1.8 Gallons                                |          |             |

| VX SERIES CONTINUED                              |                 |             |                      |                 |                |               |           |                     |
|--------------------------------------------------|-----------------|-------------|----------------------|-----------------|----------------|---------------|-----------|---------------------|
| (NATURAL GAS - LESS SYSTEM PUMP)                 |                 |             |                      |                 |                |               |           |                     |
| BOILER MODEL                                     | ITEM NUMBER     | TRADE PRICE | INPUT (MBH) MAX/ MIN | HTG. CAP. (MBH) | AHRI NET (MBH) | AFUE RATING % | FLUE DIA. | BLR./ SHP WGT. LBS. |
| VX-50                                            | HVX105003500103 | \$3,563     | 50/10                | 46              | 40             | 95            | 2"        | 91/111              |
| VX-75                                            | HVX107503500103 | \$3,661     | 75/15                | 69              | 60             | 95            | 2"        | 91/111              |
| VX-100                                           | HVX110003500103 | \$3,839     | 100/20               | 91              | 79             | 95            | 2"        | 91/111              |
| VX-150                                           | HVX115003500103 | \$4,909     | 150/30               | 139             | 121            | 95            | 3"        | 157/182             |
| VX-200                                           | HVX120003500103 | \$5,089     | 200/40               | 185             | 161            | 95            | 3"        | 157/182             |
| (NATURAL GAS - LESS SYSTEM PUMP - HIGH ALTITUDE) |                 |             |                      |                 |                |               |           |                     |
| BOILER MODEL                                     | ITEM NUMBER     | TRADE PRICE | INPUT (MBH) MAX/ MIN | HTG. CAP. (MBH) | AHRI NET (MBH) | AFUE RATING % | FLUE DIA. | BLR./ SHP WGT. LBS. |
| VX-50                                            | HVX105003502103 | \$3,563     | 50/10                | 46              | 40             | 95            | 2"        | 91/111              |
| VX-75                                            | HVX107503502103 | \$3,661     | 75/15                | 69              | 60             | 95            | 2"        | 91/111              |
| VX-100                                           | HVX110003502103 | \$3,839     | 100/20               | 91              | 79             | 95            | 2"        | 91/111              |
| VX-150                                           | HVX115003502103 | \$4,909     | 150/30               | 139             | 121            | 95            | 3"        | 157/182             |
| VX-200                                           | HVX120003502103 | \$5,090     | 200/40               | 185             | 161            | 95            | 3"        | 157/182             |
| (NATURAL GAS - TACO PUMP)                        |                 |             |                      |                 |                |               |           |                     |
| BOILER MODEL                                     | ITEM NUMBER     | TRADE PRICE | INPUT (MBH) MAX/ MIN | HTG. CAP. (MBH) | AHRI NET (MBH) | AFUE RATING % | FLUE DIA. | BLR./ SHP WGT. LBS. |
| VX-50                                            | HVX105003510103 | \$3,691     | 50/10                | 46              | 40             | 95            | 2"        | 91/111              |
| VX-75                                            | HVX107503510103 | \$3,789     | 75/15                | 69              | 60             | 95            | 2"        | 91/111              |
| VX-100                                           | HVX110003510103 | \$3,967     | 100/20               | 91              | 79             | 95            | 2"        | 91/111              |
| VX-150                                           | HVX115003510103 | \$5,037     | 150/30               | 139             | 121            | 95            | 3"        | 157/182             |
| VX-200                                           | HVX120003510103 | \$5,217     | 200/40               | 185             | 161            | 95            | 3"        | 157/182             |

| VX SERIES CONTINUED                           |                 |             |                      |                 |                |               |           |                     |
|-----------------------------------------------|-----------------|-------------|----------------------|-----------------|----------------|---------------|-----------|---------------------|
| (NATURAL GAS - TACO PUMP - HIGH ALTITUDE)     |                 |             |                      |                 |                |               |           |                     |
| BOILER MODEL                                  | ITEM NUMBER     | TRADE PRICE | INPUT (MBH) MAX/ MIN | HTG. CAP. (MBH) | AHRI NET (MBH) | AFUE RATING % | FLUE DIA. | BLR./ SHP WGT. LBS. |
| VX-50                                         | HVX105003512103 | \$3,691     | 50/10                | 46              | 40             | 95            | 2"        | 91/111              |
| VX-75                                         | HVX107503512103 | \$3,789     | 75/15                | 69              | 60             | 95            | 2"        | 91/111              |
| VX-100                                        | HVX110003512103 | \$3,967     | 100/20               | 91              | 79             | 95            | 2"        | 91/111              |
| VX-150                                        | HVX115003512103 | \$5,037     | 150/30               | 139             | 121            | 95            | 3"        | 157/182             |
| VX-200                                        | HVX120003512103 | \$5,217     | 200/40               | 185             | 161            | 95            | 3"        | 157/182             |
| (NATURAL GAS - GRUNDFOS PUMP)                 |                 |             |                      |                 |                |               |           |                     |
| BOILER MODEL                                  | ITEM NUMBER     | TRADE PRICE | INPUT (MBH) MAX/ MIN | HTG. CAP. (MBH) | AHRI NET (MBH) | AFUE RATING % | FLUE DIA. | BLR./ SHP WGT. LBS. |
| VX-50                                         | HVX105003520103 | \$3,691     | 50/10                | 46              | 40             | 95            | 2"        | 91/111              |
| VX-75                                         | HVX107503520103 | \$3,789     | 75/15                | 69              | 60             | 95            | 2"        | 91/111              |
| VX-100                                        | HVX110003520103 | \$3,967     | 100/20               | 91              | 79             | 95            | 2"        | 91/111              |
| VX-150                                        | HVX115003520103 | \$5,037     | 150/30               | 139             | 121            | 95            | 3"        | 157/182             |
| VX-200                                        | HVX120003522103 | \$5,217     | 200/40               | 185             | 161            | 95            | 3"        | 157/182             |
| (NATURAL GAS - GRUNDFOS PUMP - HIGH ALTITUDE) |                 |             |                      |                 |                |               |           |                     |
| BOILER MODEL                                  | ITEM NUMBER     | TRADE PRICE | INPUT (MBH) MAX/ MIN | HTG. CAP. (MBH) | AHRI NET (MBH) | AFUE RATING % | FLUE DIA. | BLR./ SHP WGT. LBS. |
| VX-50                                         | HVX105003522103 | \$3,691     | 50/10                | 46              | 40             | 95            | 2"        | 91/111              |
| VX-75                                         | HVX107503522103 | \$3,789     | 75/15                | 69              | 60             | 95            | 2"        | 91/111              |
| VX-100                                        | HVX110003522103 | \$3,967     | 100/20               | 91              | 79             | 95            | 2"        | 91/111              |
| VX-150                                        | HVX115003522103 | \$5,037     | 150/30               | 139             | 121            | 95            | 3"        | 157/182             |
| VX-200                                        | HVX120003521103 | \$5,217     | 200/40               | 185             | 161            | 95            | 3"        | 157/182             |

| <b>VX SERIES CONTINUED</b>                                                         |                  |              |
|------------------------------------------------------------------------------------|------------------|--------------|
| <b>VX SERIES - VENTING OPTIONS/ADDITIONAL EQUIPMENT<br/>(USE PARTS MULTIPLIER)</b> | <b>PN</b>        | <b>TRADE</b> |
| <b>050 NATURAL TO LP AND LP TO NATURAL GAS CONVERSION KIT</b>                      | <b>550002303</b> | <b>\$46</b>  |
| <b>075 NATURAL TO LP AND LP TO NATURAL GAS CONVERSION KIT</b>                      | <b>550002304</b> | <b>\$46</b>  |
| <b>100 NATURAL TO LP AND LP TO NATURAL GAS CONVERSION KIT</b>                      | <b>550002305</b> | <b>\$46</b>  |
| <b>150 NATURAL TO LP AND LP TO NATURAL GAS CONVERSION KIT</b>                      | <b>550002306</b> | <b>\$46</b>  |
| <b>200 NATURAL TO LP AND LP TO NATURAL GAS CONVERSION KIT</b>                      | <b>550002307</b> | <b>\$46</b>  |
| <b>2" CONCENTRIC VENT KIT</b>                                                      | <b>29570</b>     | <b>\$218</b> |
| <b>3" CONCENTRIC VENT KIT</b>                                                      | <b>29571</b>     | <b>\$218</b> |
| <b>MULTIPLE BOILER SENSOR KIT</b>                                                  | <b>550002186</b> | <b>\$78</b>  |
| <b>FLOOR STAND KIT</b>                                                             | <b>240010266</b> | <b>\$587</b> |

**VX SERIES - STANDARD EQUIPMENT**

**STANDARD EQUIPMENT:**

- Wall Mounted: Bracket included.
- Boiler Control Module: Automatic Low Voltage/Intermittent Direct Spark Ignition/Modulating with a 5:1 combustion turn down ratio. For multiple boiler applications - the control module can stage up to 16 boilers.
- User Display interface: Easy programming with text display. Outdoor Temperature Sensor included.
- Heat Exchanger: High grade 316L/444 Stainless Steel Fin Coil with Flame Sight Glass.
- Combustion: Gas Valve with Premix Venturi and Blower, Durable Stainless Steel Mesh Modulating Burner with 5:1 turn down ratio, Direct Spark Igniter, Flame Sensor.
- Electrical: Low Voltage Terminal Strip, High Voltage Junction Box and Transformer.
- Other: 30 PSI Safety Relief Valve, Boiler Drain Valve and Condensate Drain with built in trap.

**Q90-100 SERIES IV**

NATURAL OR PROPANE

CONDENSING HOT WATER BOILER

50 psi  
MAWP

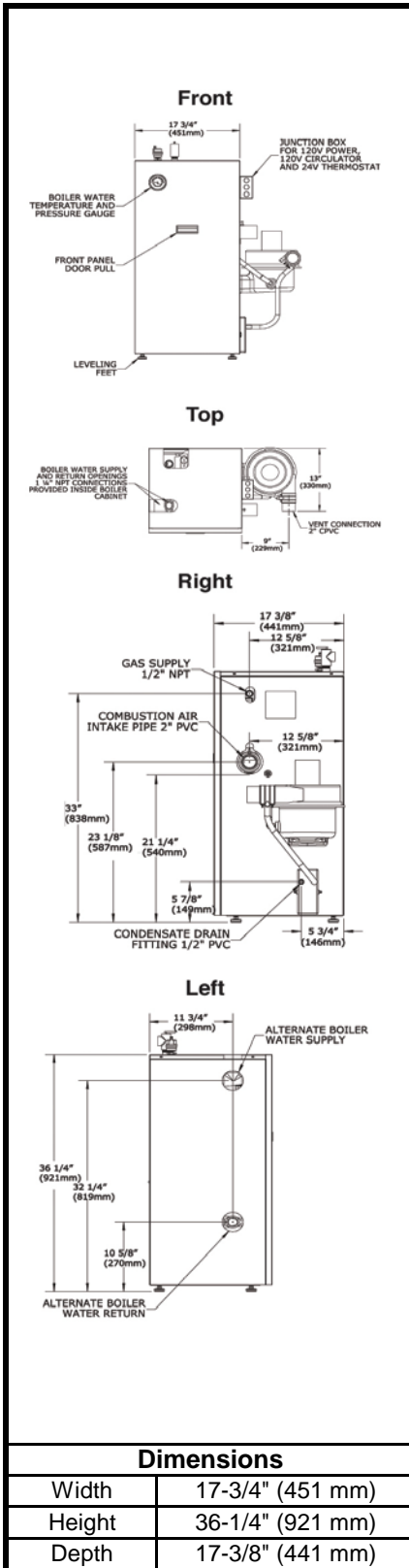

**General Information** (See IOM for complete instructions)

| Clearances                                                                                                                | Combustible Materials (Required) (1)         |                                                                                                   |                         |                | Service (2) |  |
|---------------------------------------------------------------------------------------------------------------------------|----------------------------------------------|---------------------------------------------------------------------------------------------------|-------------------------|----------------|-------------|--|
|                                                                                                                           | (1) Required distances measured from boiler. | <b>Top</b>                                                                                        | 1" (26 mm)              |                | 8" (204 mm) |  |
| <b>Left Side</b>                                                                                                          |                                              | 1" (26 mm)                                                                                        |                         | N/A            |             |  |
| <b>Right Side</b>                                                                                                         |                                              | 11" (280 mm)                                                                                      |                         | N/A            |             |  |
| <b>Base</b>                                                                                                               |                                              | 1" (26 mm)                                                                                        |                         | N/A            |             |  |
| <b>Front</b>                                                                                                              |                                              | 1" (26 mm)                                                                                        |                         | 24" (610 mm)   |             |  |
| <b>Back</b>                                                                                                               |                                              | 1" (26 mm)                                                                                        |                         | N/A            |             |  |
| (2) Service, proper operation clearance recommendation.                                                                   | <b>Combustion Air/Vent Piping</b>            | 0" (0 mm)                                                                                         |                         | N/A            |             |  |
| Combustion Air & Vent Pipe Equivalent Length (Schedule 40 PVC)                                                            | <b>Min. Length</b>                           | 2" Pipe                                                                                           | 2" Pipe                 | 3" Pipe        | 3" Pipe     |  |
|                                                                                                                           |                                              | 050                                                                                               | 100                     | 050            | 100         |  |
|                                                                                                                           | <b>Max. Length</b>                           | 2 Ft.                                                                                             | 2 Ft.                   | 20 Ft.         | 15 Ft.      |  |
|                                                                                                                           |                                              | (.61 m)                                                                                           | (.61 m)                 | (6.09 m)       | (4.57 m)    |  |
|                                                                                                                           |                                              | 26 Ft.                                                                                            | 21 Ft.                  | 112 Ft.        | 92 Ft.      |  |
|                                                                                                                           |                                              | (7.92 m)                                                                                          | (6.40 m)                | (34.14 m)      | (28.04 m)   |  |
| Note: Refer to IOM and vent pipe manufacturer's instructions for equivalent vent lengths and alternate venting materials. |                                              |                                                                                                   |                         |                |             |  |
| <b>Connections</b>                                                                                                        | <b>Return/Supply Water</b>                   | <b>Gas In</b>                                                                                     | <b>Condensate Drain</b> |                |             |  |
| <b>Dimensions</b>                                                                                                         | <b>050/075/100</b>                           | 1-1/4" NPT                                                                                        | 1/2" NPT                | 1/2" CPVC Stub |             |  |
| Width                                                                                                                     | 17-3/4" (451 mm)                             | <b>Electrical</b> 120 Volts AC, 60 hertz, 1 phase, Less than 12 amps (15 amp circuit recommended) |                         |                |             |  |
| Height                                                                                                                    | 36-1/4" (921 mm)                             |                                                                                                   |                         |                |             |  |
| Depth                                                                                                                     | 17-3/8" (441 mm)                             |                                                                                                   |                         |                |             |  |
| <b>Water Content</b>                                                                                                      |                                              | 050/075/100 - 2.6 Gallons                                                                         |                         |                |             |  |

| Q90-100 SERIES IV CONTINUED               |                 |             |             |                 |                |               |           |           |
|-------------------------------------------|-----------------|-------------|-------------|-----------------|----------------|---------------|-----------|-----------|
| (NATURAL GAS - LESS SYSTEM PUMP)          |                 |             |             |                 |                |               |           |           |
| BOILER MODEL                              | ITEM NUMBER     | TRADE PRICE | INPUT (MBH) | HTG. CAP. (MBH) | AHRI NET (MBH) | AFUE RATING % | FLUE DIA. | SHIP WGT. |
| Q90-50                                    | Q90205003200403 | \$3,149     | 50          | 45              | 39             | 90            | 2" or 3"  | 256       |
| Q90-75                                    | Q90207503200403 | \$3,149     | 75          | 68              | 59             | 90            | 2" or 3"  | 256       |
| Q90-100                                   | Q90210003200403 | \$3,149     | 100         | 90              | 78             | 90            | 2" or 3"  | 256       |
| (NATURAL GAS - WITH TACO SYSTEM PUMP)     |                 |             |             |                 |                |               |           |           |
| BOILER MODEL                              | ITEM NUMBER     | TRADE PRICE | INPUT (MBH) | HTG. CAP. (MBH) | AHRI NET (MBH) | AFUE RATING % | FLUE DIA. | SHIP WGT. |
| Q90-50                                    | Q90205003210403 | \$3,214     | 50          | 45              | 39             | 90            | 2" or 3"  | 256       |
| Q90-75                                    | Q90207503210403 | \$3,214     | 75          | 68              | 59             | 90            | 2" or 3"  | 256       |
| Q90-100                                   | Q90210003210403 | \$3,214     | 100         | 90              | 78             | 90            | 2" or 3"  | 256       |
| (NATURAL GAS - WITH GRUNDFOS SYSTEM PUMP) |                 |             |             |                 |                |               |           |           |
| BOILER MODEL                              | ITEM NUMBER     | TRADE PRICE | INPUT (MBH) | HTG. CAP. (MBH) | AHRI NET (MBH) | AFUE RATING % | FLUE DIA. | SHIP WGT. |
| Q90-50                                    | Q90205003220403 | \$3,214     | 50          | 45              | 39             | 90            | 2" or 3"  | 256       |
| Q90-75                                    | Q90207503220403 | \$3,214     | 75          | 68              | 59             | 90            | 2" or 3"  | 256       |
| Q90-100                                   | Q90210003220403 | \$3,214     | 100         | 90              | 78             | 90            | 2" or 3"  | 256       |
| (LP GAS - LESS SYSTEM PUMP)               |                 |             |             |                 |                |               |           |           |
| BOILER MODEL                              | ITEM NUMBER     | TRADE PRICE | INPUT (MBH) | HTG. CAP. (MBH) | AHRI NET (MBH) | AFUE RATING % | FLUE DIA. | SHIP WGT. |
| Q90-50                                    | Q90205013200403 | \$3,149     | 50          | 45              | 39             | 90            | 2" or 3"  | 256       |
| Q90-75                                    | Q90207513200403 | \$3,149     | 75          | 68              | 59             | 90            | 2" or 3"  | 256       |
| Q90-100                                   | Q90210013200403 | \$3,149     | 100         | 90              | 78             | 90            | 2" or 3"  | 256       |
| (LP GAS - WITH TACO SYSTEM PUMP)          |                 |             |             |                 |                |               |           |           |
| BOILER MODEL                              | ITEM NUMBER     | TRADE PRICE | INPUT (MBH) | HTG. CAP. (MBH) | AHRI NET (MBH) | AFUE RATING % | FLUE DIA. | SHIP WGT. |
| Q90-50                                    | Q90205013210403 | \$3,214     | 50          | 45              | 39             | 90            | 2" or 3"  | 256       |
| Q90-75                                    | Q90207513210403 | \$3,214     | 75          | 68              | 59             | 90            | 2" or 3"  | 256       |
| Q90-100                                   | Q90210013210403 | \$3,214     | 100         | 90              | 78             | 90            | 2" or 3"  | 256       |
| (LP GAS - WITH GRUNDFOS SYSTEM PUMP)      |                 |             |             |                 |                |               |           |           |
| BOILER MODEL                              | ITEM NUMBER     | TRADE PRICE | INPUT (MBH) | HTG. CAP. (MBH) | AHRI NET (MBH) | AFUE RATING % | FLUE DIA. | SHIP WGT. |
| Q90-50                                    | Q90205013220403 | \$3,214     | 50          | 45              | 39             | 90            | 2" or 3"  | 256       |
| Q90-75                                    | Q90207513220403 | \$3,214     | 75          | 68              | 59             | 90            | 2" or 3"  | 256       |
| Q90-100                                   | Q90210013220403 | \$3,214     | 100         | 90              | 78             | 90            | 2" or 3"  | 256       |

| Q90-100 SERIES IV CONTINUED                                                                                                                                                                                                                                                                                                                                                                                                                                                                                                                                                                                                                                                                                                             |           |         |
|-----------------------------------------------------------------------------------------------------------------------------------------------------------------------------------------------------------------------------------------------------------------------------------------------------------------------------------------------------------------------------------------------------------------------------------------------------------------------------------------------------------------------------------------------------------------------------------------------------------------------------------------------------------------------------------------------------------------------------------------|-----------|---------|
| (USE PARTS MULTIPLIER FOR ALL OF THE FOLLOWING)                                                                                                                                                                                                                                                                                                                                                                                                                                                                                                                                                                                                                                                                                         | PN        | TRADE   |
| CONCENTRIC VENT KIT 3"                                                                                                                                                                                                                                                                                                                                                                                                                                                                                                                                                                                                                                                                                                                  | 29571     | \$218   |
| CONCENTRIC VENT KIT 2"                                                                                                                                                                                                                                                                                                                                                                                                                                                                                                                                                                                                                                                                                                                  | 29570     | \$218   |
| ARGO AMB MULTIPLE BOILER CONTROL (INCLUDES OUTDOOR RESET, PRIORITY OVERRIDE, LEAD BOILER RUN TIME ROTATION):                                                                                                                                                                                                                                                                                                                                                                                                                                                                                                                                                                                                                            |           |         |
| AMB4A TO ALLOW STAGE FIRING OF UP TO 4 BOILERS                                                                                                                                                                                                                                                                                                                                                                                                                                                                                                                                                                                                                                                                                          | AMB4AD    | \$1,000 |
| AMB8A TO ALLOW STAGE FIRING OF UP TO 8 BOILERS                                                                                                                                                                                                                                                                                                                                                                                                                                                                                                                                                                                                                                                                                          | AMB8AD    | \$1,450 |
| CONVERSION KIT NAT. TO LP Q90-50 (Series IV) 0' - 10,000'                                                                                                                                                                                                                                                                                                                                                                                                                                                                                                                                                                                                                                                                               | 550002631 | \$75    |
| CONVERSION KIT NAT. TO LP Q90-75 (Series IV) 5,000' - 10,000'                                                                                                                                                                                                                                                                                                                                                                                                                                                                                                                                                                                                                                                                           | 550002629 | \$75    |
| CONVERSION KIT NAT. TO LP Q90-75 (Series IV) 0' - 5,000'                                                                                                                                                                                                                                                                                                                                                                                                                                                                                                                                                                                                                                                                                | 550002630 | \$75    |
| CONVERSION KIT NAT. TO LP Q90-100 (Series IV) 0' - 10,000'                                                                                                                                                                                                                                                                                                                                                                                                                                                                                                                                                                                                                                                                              | 550002700 | \$75    |
| CONVERSION KIT LP TO NAT. Q90-50 (Series IV) 0' - 10,000'                                                                                                                                                                                                                                                                                                                                                                                                                                                                                                                                                                                                                                                                               | 550002635 | \$75    |
| CONVERSION KIT LP TO NAT. Q90-75 (Series IV) 0' - 10,000'                                                                                                                                                                                                                                                                                                                                                                                                                                                                                                                                                                                                                                                                               | 550002634 | \$75    |
| CONVERSION KIT LP TO NAT. Q90-100 (Series IV) 0' - 10,000'                                                                                                                                                                                                                                                                                                                                                                                                                                                                                                                                                                                                                                                                              | 550002701 | \$75    |
| 2" CPVC 45° ELBOW (Q90-100 Series)                                                                                                                                                                                                                                                                                                                                                                                                                                                                                                                                                                                                                                                                                                      | 14631702  | \$37    |
| 2" CPVC 90° ELBOW (Q90-100 Series)                                                                                                                                                                                                                                                                                                                                                                                                                                                                                                                                                                                                                                                                                                      | 240009663 | \$26    |
| 2" CPVC TEE, SCHEDULE 80 (Q90-100 Series)                                                                                                                                                                                                                                                                                                                                                                                                                                                                                                                                                                                                                                                                                               | 240006819 | \$36    |
| 2" CPVC COUPLING (Q90-100 Series)                                                                                                                                                                                                                                                                                                                                                                                                                                                                                                                                                                                                                                                                                                       | 240006822 | \$23    |
| FILL-TROL #110 FOR WATER BOILERS 150 MBH OR LESS                                                                                                                                                                                                                                                                                                                                                                                                                                                                                                                                                                                                                                                                                        | 14624002  | \$291   |
| FILL-TROL #111 FOR WATER BOILERS OVER 150 MBH                                                                                                                                                                                                                                                                                                                                                                                                                                                                                                                                                                                                                                                                                           | 14624003  | \$392   |
| Q90-100 SERIES IV - STANDARD EQUIPMENT                                                                                                                                                                                                                                                                                                                                                                                                                                                                                                                                                                                                                                                                                                  |           |         |
| <b><u>STANDARD EQUIPMENT:</u></b>                                                                                                                                                                                                                                                                                                                                                                                                                                                                                                                                                                                                                                                                                                       |           |         |
| <ul style="list-style-type: none"> <li>- Boiler Control Module: HSI Integrated Boiler Control</li> <li>- Combination Hydrolevel High Limit with LWCO with boiler water temperature reset feature</li> <li>- Heat Exchanger: Cast Aluminum Heat Exchanger</li> <li>- Combustion: Stainless Steel Premix Burner</li> <li>- Induced Draft Blower with adjustable exhaust (front, right side or rear), Inducer Motor Assembly, includes 5' schedule 80 2" CPVC and CPVC Tee</li> <li>- Electrical: Junction Box, Transformer and Wiring Harness</li> <li>- Textured painted steel jacket</li> <li>- Other: Temperature/Pressure Gauge, 30 PSI Safety Relief Valve, Pressure Switch(es), Low Profile Condensate Trap and Air Vent</li> </ul> |           |         |

**DWB SERIES**

NATURAL OR PROPANE (WITH CONVERSION KIT)

MODULATING 3:1

SPACE HEATING ONLY BOILER & COMBI UNIT WITH DHW  
(CHIMNEY/SIDEWALL VENTED)

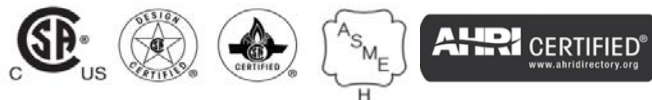

43.5 psi MAWP

**DWB Combi Unit  
(CCB-150) Shown**

See IOM for dimensions  
on other models.

**TOP**

Width 17-23/32"

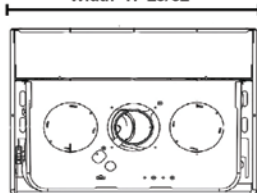

**FRONT**

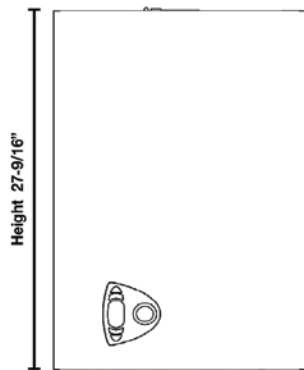

**SIDE**

Depth 13"



**General Information (See IOM for complete instructions)**

| Clearances                        |            | Combustible Materials (Required) <sup>(1)</sup>                                                                | Service <sup>(1) (2)</sup> |
|-----------------------------------|------------|----------------------------------------------------------------------------------------------------------------|----------------------------|
|                                   |            | (1) Required distances measured from boiler jacket.<br>(2) Service, proper operation clearance recommendation. | <b>Top</b>                 |
| <b>Left Side</b>                  | 0" (0 cm)  |                                                                                                                | 1" (3 cm)                  |
| <b>Right Side</b>                 | 0" (0 cm)  |                                                                                                                | 1" (3 cm)                  |
| <b>Front</b>                      | 0" (0 cm)  |                                                                                                                | 1" (3 cm)                  |
| <b>Back</b>                       | 0" (0 cm)  |                                                                                                                | 0" (0 cm)                  |
| <b>Bottom</b>                     | 0" (0 cm)  |                                                                                                                | 12" (30 cm)                |
| <b>Combustion Air/Vent Piping</b> | 0" (0 cm)  |                                                                                                                | 3/8" (1 cm)                |
| <b>Vent Piping</b>                | 6" (15 cm) |                                                                                                                | 6" (15 cm)                 |

**Connections**

|                            |                                                                                   |
|----------------------------|-----------------------------------------------------------------------------------|
| CCB-150                    | Return/Supply Water 1", Gas In 3/4" NPT, Domestic Hot Water Inlet/Outlet 3/4" NPT |
| CHB-100, CHB-130 & CHB-150 | Return/Supply Water 1", Gas In 3/4" NPT, Indirect Tank 3/4" NPT                   |
| <b>Electrical</b>          | 120 Volts AC, 60 hertz, 1 phase, Less than 12 amps (15 amp circuit recommended)   |
| <b>Water Content</b>       | CCB-150/CHB-150 - .396 Gallons, CHB-130 - .317 Gallons, CHB-100 - .211 Gallons    |

**Dimensions**

| Model           | Width     | Height   | Depth |
|-----------------|-----------|----------|-------|
| CCB-150/CHB-150 | 17-23/32" | 27-9/16" | 13"   |
| CHB-130         | 15-3/4"   | 27-9/16" | 13"   |
| CHB-100         | 15-3/4"   | 27-9/16" | 13"   |



| DWB SERIES CONTINUED                                                                                                                                                                                                                                                     |               |             |                  |                 |                |               |                            |                    |           |
|--------------------------------------------------------------------------------------------------------------------------------------------------------------------------------------------------------------------------------------------------------------------------|---------------|-------------|------------------|-----------------|----------------|---------------|----------------------------|--------------------|-----------|
| (NATURAL GAS - LESS SYSTEM PUMP, COMBI WITH DOMESTIC HOT WATER)                                                                                                                                                                                                          |               |             |                  |                 |                |               |                            |                    |           |
| BOILER MODEL                                                                                                                                                                                                                                                             | ITEM NUMBER   | TRADE PRICE | INPUT RATE (MBH) | HTG. CAP. (MBH) | AHRI NET (MBH) | AFUE RATING % | CHIMNEY CAT. I (Min. Size) | SIDE-WALL CAT. III | SHIP WGT. |
| CCB150                                                                                                                                                                                                                                                                   | CCB0150000103 | \$2,142     | 150              | 127             | 110            | 85.0          | 4"                         | 3"                 | 78        |
| (NATURAL GAS - LESS SYSTEM PUMP, SPACE HEATING ONLY)                                                                                                                                                                                                                     |               |             |                  |                 |                |               |                            |                    |           |
| BOILER MODEL                                                                                                                                                                                                                                                             | ITEM NUMBER   | TRADE PRICE | INPUT RATE (MBH) | HTG. CAP. (MBH) | AHRI NET (MBH) | AFUE RATING % | CHIMNEY CAT. I (Min. Size) | SIDE-WALL CAT. III | SHIP WGT. |
| CHB100                                                                                                                                                                                                                                                                   | CHB0100000103 | \$1,658     | 100              | 85              | 73             | 85.0          | 4"                         | 3"                 | 65        |
| CHB130                                                                                                                                                                                                                                                                   | CHB0130000103 | \$1,839     | 130              | 110             | 96             | 85.0          | 4"                         | 3"                 | 69        |
| CHB150                                                                                                                                                                                                                                                                   | CHB0150000103 | \$1,945     | 150              | 130             | 110            | 85.0          | 4"                         | 3"                 | 73        |
| (USE PARTS MULTIPLIER FOR ALL OF THE FOLLOWING)                                                                                                                                                                                                                          |               |             |                  |                 |                | PN            | TRADE                      |                    |           |
| NATURAL TO LP CONVERSION KIT (CCB150 & CHB150)                                                                                                                                                                                                                           |               |             |                  |                 |                | FE3980C150    | \$20                       |                    |           |
| NATURAL TO LP CONVERSION KIT (CHB130)                                                                                                                                                                                                                                    |               |             |                  |                 |                | FE3980B950    | \$18                       |                    |           |
| NATURAL TO LP CONVERSION KIT (CHB100)                                                                                                                                                                                                                                    |               |             |                  |                 |                | FE3980C300    | \$14                       |                    |           |
| DIRECT VENT KIT                                                                                                                                                                                                                                                          |               |             |                  |                 |                | 5612601       | \$142                      |                    |           |
| OUTSIDE AIR SENSOR                                                                                                                                                                                                                                                       |               |             |                  |                 |                | FE013018X0    | \$26                       |                    |           |
| DHW SENSOR KIT                                                                                                                                                                                                                                                           |               |             |                  |                 |                | 550002958     | \$53                       |                    |           |
| FLOOR STAND KIT                                                                                                                                                                                                                                                          |               |             |                  |                 |                | 240010266     | \$587                      |                    |           |
| DWB SERIES - STANDARD EQUIPMENT                                                                                                                                                                                                                                          |               |             |                  |                 |                |               |                            |                    |           |
| <b><u>STANDARD EQUIPMENT:</u></b>                                                                                                                                                                                                                                        |               |             |                  |                 |                |               |                            |                    |           |
| -Boiler Control Module: High Limit/Electronic Ignitional Control.                                                                                                                                                                                                        |               |             |                  |                 |                |               |                            |                    |           |
| -User Display Interface: Digital Temperature Display with diagnostics and programmable settings.                                                                                                                                                                         |               |             |                  |                 |                |               |                            |                    |           |
| -Heat Exchanger: Copper Fin Tube.                                                                                                                                                                                                                                        |               |             |                  |                 |                |               |                            |                    |           |
| (CCB-150 combination boiler includes a stainless steel brazed plate heat exchanger - 3.6 gpm at 70°F Temperature Rise, 6.3 gpm at 40°F Temperature Rise)                                                                                                                 |               |             |                  |                 |                |               |                            |                    |           |
| Valve: 3-Way Water Diverting Valve                                                                                                                                                                                                                                       |               |             |                  |                 |                |               |                            |                    |           |
| -Combustion: Completely Installed and Wired Modulating Gas Control System (100% to 33%) with Stainless Steel Burners and Manifold consisting of: Automatic Modulating Gas Valve, Direct Spark Ignition Control, 100% Shut Off, Combination Spark Electrode/Flame Sensor. |               |             |                  |                 |                |               |                            |                    |           |
| -Safety: Pressure Switch (vent safety shutoff).                                                                                                                                                                                                                          |               |             |                  |                 |                |               |                            |                    |           |
| -Other: Assembled Boiler with Jacket, Induced Draft Fan, Combination Temperature/ Pressure Gauge, Circulator Pump. Gas Shut Off Valve and Field installed - 30lb. ASME Relief Valve.                                                                                     |               |             |                  |                 |                |               |                            |                    |           |

**DXL SERIES**

NATURAL OR PROPANE  
HOT WATER BOILER  
CHIMNEY VENTED  
(ENCLOSED CONTROLS)

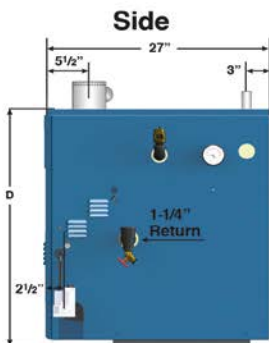

Note: For sizes greater than 200 MBH, utilize WPSB Boilers.

**General Information** (See IOM for complete instructions)

| Clearances | Combustible Materials (Required) (1)         |             |
|------------|----------------------------------------------|-------------|
|            | (1) Required distances measured from boiler. | Top         |
|            | Front                                        | Alcove*     |
|            | Flue Connector                               | 6" (152 mm) |
|            | Rear                                         | 4" (102 mm) |
|            | Right Side                                   | 9" (229 mm) |
|            | Other Side                                   | 3" (76 mm)  |

\*Definition of Alcove is three sided space with no wall in front of boiler. ANSI standard for alcove is 18 inches from appliance to leading edge of side walls as shown in IOM.

| Connections   | Return/Supply Water                                                                  | Gas In 050/075/100/125/150 | Gas In 170/200 |
|---------------|--------------------------------------------------------------------------------------|----------------------------|----------------|
| All Models    | 1-1/4" NPT                                                                           | 1/2" NPT                   | 3/4" NPT       |
| Electrical    | 120 Volts AC, 60 hertz, 1 phase, Less than 12 amps (15 amp circuit recommended)      |                            |                |
| Water Content | 50 - 2.4 Gallons, 75/100 - 4.0 Gallons, 125/150 - 5.6 Gallons, 170/200 - 7.2 Gallons |                            |                |

**Dimensions**

| Model   | A       | B       | C  | D       | E       | F      |
|---------|---------|---------|----|---------|---------|--------|
| DXL-50  | 11-1/8" | 5-1/2"  | 4" | 30-3/4" | 36-3/4" | 6"     |
| DXL-75  | 15"     | 7-1/2"  | 5" | 30-3/4" | 36-3/4" | 6"     |
| DXL-100 | 15"     | 7-1/2"  | 6" | 30-3/4" | 37-1/4" | 6-1/2" |
| DXL-125 | 18-7/8" | 9-1/2"  | 6" | 30-3/4" | 37-1/4" | 6-1/2" |
| DXL-150 | 18-7/8" | 9-1/2"  | 7" | 30-3/4" | 37-3/4" | 7"     |
| DXL-170 | 22-3/4" | 11-1/2" | 7" | 30-3/4" | 38-3/4" | 7"     |
| DXL-200 | 22-3/4" | 11-1/2" | 8" | 30-3/4" | 38-3/4" | 8"     |

| DXL SERIES CONTINUED                                 |                 |             |             |                 |                |               |           |           |
|------------------------------------------------------|-----------------|-------------|-------------|-----------------|----------------|---------------|-----------|-----------|
| (NATURAL GAS - LESS SYSTEM PUMP)                     |                 |             |             |                 |                |               |           |           |
| BOILER MODEL                                         | ITEM NUMBER     | TRADE PRICE | INPUT (MBH) | HTG. CAP. (MBH) | AHRI NET (MBH) | AFUE RATING % | FLUE DIA. | SHIP WGT. |
| DXL-50                                               | DXL205003200203 | \$1,907     | 50          | 42              | 37             | 83.5          | 4"        | 205       |
| DXL-75                                               | DXL307503200203 | \$2,142     | 75          | 63              | 55             | 83.1          | 5"        | 253       |
| DXL-100                                              | DXL310003200203 | \$2,243     | 100         | 83              | 72             | 83.0          | 6"        | 253       |
| DXL-125                                              | DXL412503200203 | \$2,437     | 125         | 104             | 90             | 82.0          | 6"        | 315       |
| DXL-150                                              | DXL415003200203 | \$2,537     | 150         | 124             | 108            | 83.0          | 7"        | 315       |
| DXL-170                                              | DXL517003200203 | \$2,989     | 170         | 139             | 121            | 82.0          | 7"        | 377       |
| DXL-200                                              | DXL520003200203 | \$3,171     | 200         | 165             | 143            | 82.0          | 8"        | 377       |
| (NATURAL GAS - WITH TACO SYSTEM PUMP)                |                 |             |             |                 |                |               |           |           |
| BOILER MODEL                                         | ITEM NUMBER     | TRADE PRICE | INPUT (MBH) | HTG. CAP. (MBH) | AHRI NET (MBH) | AFUE RATING % | FLUE DIA. | SHIP WGT. |
| DXL-50                                               | DXL205003210203 | \$1,977     | 50          | 42              | 37             | 83.5          | 4"        | 205       |
| DXL-75                                               | DXL307503210203 | \$2,212     | 75          | 63              | 55             | 83.1          | 5"        | 253       |
| DXL-100                                              | DXL310003210203 | \$2,312     | 100         | 83              | 72             | 83.0          | 6"        | 253       |
| DXL-125                                              | DXL412503210203 | \$2,506     | 125         | 104             | 90             | 82.0          | 6"        | 315       |
| DXL-150                                              | DXL415003210203 | \$2,606     | 150         | 124             | 108            | 83.0          | 7"        | 315       |
| DXL-170                                              | DXL517003210203 | \$3,059     | 170         | 139             | 121            | 82.0          | 7"        | 377       |
| DXL-200                                              | DXL520003210203 | \$3,241     | 200         | 165             | 143            | 82.0          | 8"        | 377       |
| (NATURAL GAS, HIGH ALTITUDE - WITH TACO SYSTEM PUMP) |                 |             |             |                 |                |               |           |           |
| BOILER MODEL                                         | ITEM NUMBER     | TRADE PRICE | INPUT (MBH) | HTG. CAP. (MBH) | AHRI NET (MBH) | AFUE RATING % | FLUE DIA. | SHIP WGT. |
| DXL-50                                               | DXL205003212203 | \$1,977     | 50          | 42              | 37             | 83.5          | 4"        | 205       |
| DXL-75                                               | DXL307503212203 | \$2,212     | 75          | 63              | 55             | 83.1          | 5"        | 253       |
| DXL-100                                              | DXL310003212203 | \$2,312     | 100         | 83              | 72             | 83.0          | 6"        | 253       |
| DXL-125                                              | DXL412503212203 | \$2,506     | 125         | 104             | 90             | 82.0          | 6"        | 315       |
| DXL-150                                              | DXL415003212203 | \$2,606     | 150         | 124             | 108            | 83.0          | 7"        | 315       |
| DXL-170                                              | DXL517003212203 | \$3,059     | 170         | 139             | 121            | 82.0          | 7"        | 377       |
| DXL-200                                              | DXL520003212203 | \$3,241     | 200         | 165             | 143            | 82.0          | 8"        | 377       |
| (NATURAL GAS - WITH GRUNDFOS SYSTEM PUMP)            |                 |             |             |                 |                |               |           |           |
| BOILER MODEL                                         | ITEM NUMBER     | TRADE PRICE | INPUT (MBH) | HTG. CAP. (MBH) | AHRI NET (MBH) | AFUE RATING % | FLUE DIA. | SHIP WGT. |
| DXL-50                                               | DXL205003220203 | \$1,977     | 50          | 42              | 37             | 83.5          | 4"        | 205       |
| DXL-75                                               | DXL307503220203 | \$2,212     | 75          | 63              | 55             | 83.1          | 5"        | 253       |
| DXL-100                                              | DXL310003220203 | \$2,312     | 100         | 83              | 72             | 83.0          | 6"        | 253       |
| DXL-125                                              | DXL412503220203 | \$2,506     | 125         | 104             | 90             | 82.0          | 6"        | 315       |
| DXL-150                                              | DXL415003220203 | \$2,606     | 150         | 124             | 108            | 83.0          | 7"        | 315       |
| DXL-170                                              | DXL517003220203 | \$3,059     | 170         | 139             | 121            | 82.0          | 7"        | 377       |
| DXL-200                                              | DXL520003220203 | \$3,241     | 200         | 165             | 143            | 82.0          | 8"        | 377       |

| DXL SERIES CONTINUED                                   |                 |             |             |                 |                |               |           |           |
|--------------------------------------------------------|-----------------|-------------|-------------|-----------------|----------------|---------------|-----------|-----------|
| (NATURAL GAS, HIGH ALTITUDE WITH GRUNDFOS SYSTEM PUMP) |                 |             |             |                 |                |               |           |           |
| BOILER MODEL                                           | ITEM NUMBER     | TRADE PRICE | INPUT (MBH) | HTG. CAP. (MBH) | AHRI NET (MBH) | AFUE RATING % | FLUE DIA. | SHIP WGT. |
| DXL-50                                                 | DXL205003222203 | \$1,977     | 50          | 42              | 37             | 83.5          | 4"        | 205       |
| DXL-75                                                 | DXL307503222203 | \$2,212     | 75          | 63              | 55             | 83.1          | 5"        | 253       |
| DXL-100                                                | DXL310003222203 | \$2,312     | 100         | 83              | 72             | 83.0          | 6"        | 253       |
| DXL-125                                                | DXL412503222203 | \$2,506     | 125         | 104             | 90             | 82.0          | 6"        | 315       |
| DXL-150                                                | DXL415003222203 | \$2,606     | 150         | 124             | 108            | 83.0          | 7"        | 315       |
| DXL-170                                                | DXL517003222203 | \$3,059     | 170         | 139             | 121            | 82.0          | 7"        | 377       |
| DXL-200                                                | DXL520003222203 | \$3,241     | 200         | 165             | 143            | 82.0          | 8"        | 377       |
| (NATURAL GAS - WITH B & G SYSTEM PUMP)                 |                 |             |             |                 |                |               |           |           |
| BOILER MODEL                                           | ITEM NUMBER     | TRADE PRICE | INPUT (MBH) | HTG. CAP. (MBH) | AHRI NET (MBH) | AFUE RATING % | FLUE DIA. | SHIP WGT. |
| DXL-50                                                 | DXL205003230203 | \$1,977     | 50          | 42              | 37             | 83.5          | 4"        | 205       |
| DXL-75                                                 | DXL307503230203 | \$2,212     | 75          | 63              | 55             | 83.1          | 5"        | 253       |
| DXL-100                                                | DXL310003230203 | \$2,312     | 100         | 83              | 72             | 83.0          | 6"        | 253       |
| DXL-125                                                | DXL412503230203 | \$2,506     | 125         | 104             | 90             | 82.0          | 6"        | 315       |
| DXL-150                                                | DXL415003230203 | \$2,606     | 150         | 124             | 108            | 83.0          | 7"        | 315       |
| DXL-170                                                | DXL517003230203 | \$3,059     | 170         | 139             | 121            | 82.0          | 7"        | 377       |
| DXL-200                                                | DXL520003230203 | \$3,241     | 200         | 165             | 143            | 82.0          | 8"        | 377       |
| (LP GAS - LESS SYSTEM PUMP)                            |                 |             |             |                 |                |               |           |           |
| BOILER MODEL                                           | ITEM NUMBER     | TRADE PRICE | INPUT (MBH) | HTG. CAP. (MBH) | AHRI NET (MBH) | AFUE RATING % | FLUE DIA. | SHIP WGT. |
| DXL-50                                                 | DXL205013200203 | \$1,956     | 50          | 42              | 37             | 83.5          | 4"        | 205       |
| DXL-75                                                 | DXL307513200203 | \$2,191     | 75          | 63              | 55             | 83.1          | 5"        | 253       |
| DXL-100                                                | DXL310013200203 | \$2,290     | 100         | 83              | 72             | 83.0          | 6"        | 253       |
| DXL-125                                                | DXL412513200203 | \$2,486     | 125         | 104             | 90             | 82.0          | 6"        | 315       |
| DXL-150                                                | DXL415013200203 | \$2,586     | 150         | 124             | 108            | 83.0          | 7"        | 315       |
| DXL-170                                                | DXL517013200203 | \$3,038     | 170         | 139             | 121            | 82.0          | 7"        | 377       |
| DXL-200                                                | DXL520013200203 | \$3,220     | 200         | 165             | 143            | 82.0          | 8"        | 377       |
| (LP GAS - WITH TACO SYSTEM PUMP)                       |                 |             |             |                 |                |               |           |           |
| BOILER MODEL                                           | ITEM NUMBER     | TRADE PRICE | INPUT (MBH) | HTG. CAP. (MBH) | AHRI NET (MBH) | AFUE RATING % | FLUE DIA. | SHIP WGT. |
| DXL-50                                                 | DXL205013210203 | \$2,026     | 50          | 42              | 37             | 83.5          | 4"        | 205       |
| DXL-75                                                 | DXL307513210203 | \$2,260     | 75          | 63              | 55             | 83.1          | 5"        | 253       |
| DXL-100                                                | DXL310013210203 | \$2,361     | 100         | 83              | 72             | 83.0          | 6"        | 253       |
| DXL-125                                                | DXL412513210203 | \$2,555     | 125         | 104             | 90             | 82.0          | 6"        | 315       |
| DXL-150                                                | DXL415013210203 | \$2,655     | 150         | 124             | 108            | 83.0          | 7"        | 315       |
| DXL-170                                                | DXL517013210203 | \$3,108     | 170         | 139             | 121            | 82.0          | 7"        | 377       |
| DXL-200                                                | DXL520013210203 | \$3,290     | 200         | 165             | 143            | 82.0          | 8"        | 377       |

| DXL SERIES CONTINUED                             |                 |             |             |                 |                |               |           |           |
|--------------------------------------------------|-----------------|-------------|-------------|-----------------|----------------|---------------|-----------|-----------|
| (LP GAS - WITH GRUNDFOS SYSTEM PUMP)             |                 |             |             |                 |                |               |           |           |
| BOILER MODEL                                     | ITEM NUMBER     | TRADE PRICE | INPUT (MBH) | HTG. CAP. (MBH) | AHRI NET (MBH) | AFUE RATING % | FLUE DIA. | SHIP WGT. |
| DXL-50                                           | DXL205013220203 | \$2,026     | 50          | 42              | 37             | 83.5          | 4"        | 205       |
| DXL-75                                           | DXL307513220203 | \$2,260     | 75          | 63              | 55             | 83.1          | 5"        | 253       |
| DXL-100                                          | DXL310013220203 | \$2,361     | 100         | 83              | 72             | 83.0          | 6"        | 253       |
| DXL-125                                          | DXL412513220203 | \$2,555     | 125         | 104             | 90             | 82.0          | 6"        | 315       |
| DXL-150                                          | DXL415013220203 | \$2,655     | 150         | 124             | 108            | 83.0          | 7"        | 315       |
| DXL-170                                          | DXL517013220203 | \$3,108     | 170         | 139             | 121            | 82.0          | 7"        | 377       |
| DXL-200                                          | DXL520013220203 | \$3,290     | 200         | 165             | 143            | 82.0          | 8"        | 377       |
| (LP GAS - WITH B & G SYSTEM PUMP)                |                 |             |             |                 |                |               |           |           |
| BOILER MODEL                                     | ITEM NUMBER     | TRADE PRICE | INPUT (MBH) | HTG. CAP. (MBH) | AHRI NET (MBH) | AFUE RATING % | FLUE DIA. | SHIP WGT. |
| DXL-50                                           | DXL205013230203 | \$2,026     | 50          | 42              | 37             | 83.5          | 4"        | 205       |
| DXL-75                                           | DXL307513230203 | \$2,260     | 75          | 63              | 55             | 83.1          | 5"        | 253       |
| DXL-100                                          | DXL310013230203 | \$2,361     | 100         | 83              | 72             | 83.0          | 6"        | 253       |
| DXL-125                                          | DXL412513230203 | \$2,555     | 125         | 104             | 90             | 82.0          | 6"        | 315       |
| DXL-150                                          | DXL415013230203 | \$2,655     | 150         | 124             | 108            | 83.0          | 7"        | 315       |
| DXL-170                                          | DXL517013230203 | \$3,108     | 170         | 139             | 121            | 82.0          | 7"        | 377       |
| DXL-200                                          | DXL520013230203 | \$3,290     | 200         | 165             | 143            | 82.0          | 8"        | 377       |
| (USE PARTS MULTIPLIER FOR ALL OF THE FOLLOWING)  |                 |             |             |                 |                | PN            | TRADE     |           |
| COMBUSTIBLE FLOOR PLATE DXL-50                   |                 |             |             |                 |                | 325-2-8.01    | \$212     |           |
| COMBUSTIBLE FLOOR PLATE DXL-75                   |                 |             |             |                 |                | 325-2-8.02    | \$222     |           |
| COMBUSTIBLE FLOOR PLATE DXL-100                  |                 |             |             |                 |                | 325-2-8.02    | \$222     |           |
| COMBUSTIBLE FLOOR PLATE DXL-125                  |                 |             |             |                 |                | 325-2-8.03    | \$244     |           |
| COMBUSTIBLE FLOOR PLATE DXL-150                  |                 |             |             |                 |                | 325-2-8.03    | \$244     |           |
| COMBUSTIBLE FLOOR PLATE DXL-170                  |                 |             |             |                 |                | 325-2-8.04    | \$244     |           |
| COMBUSTIBLE FLOOR PLATE DXL-200                  |                 |             |             |                 |                | 325-2-8.04    | \$244     |           |
| CONVERSION KIT NAT. TO LP DXL-50                 |                 |             |             |                 |                | 550002663     | \$82      |           |
| CONVERSION KIT NAT. TO LP DXL-75                 |                 |             |             |                 |                | 550002664     | \$82      |           |
| CONVERSION KIT NAT. TO LP DXL-100                |                 |             |             |                 |                | 550002663     | \$82      |           |
| CONVERSION KIT NAT. TO LP DXL-125                |                 |             |             |                 |                | 550002665     | \$82      |           |
| CONVERSION KIT NAT. TO LP DXL-150                |                 |             |             |                 |                | 550002663     | \$82      |           |
| CONVERSION KIT NAT. TO LP DXL-170                |                 |             |             |                 |                | 550002665     | \$82      |           |
| CONVERSION KIT NAT. TO LP DXL-200                |                 |             |             |                 |                | 550002663     | \$82      |           |
| CONVERSION KIT LP TO NAT. DXL-50                 |                 |             |             |                 |                | 5611902       | \$100     |           |
| CONVERSION KIT LP TO NAT. DXL-75                 |                 |             |             |                 |                | 5611903       | \$102     |           |
| CONVERSION KIT LP TO NAT. DXL-100                |                 |             |             |                 |                | 5611904       | \$102     |           |
| CONVERSION KIT LP TO NAT. DXL-125                |                 |             |             |                 |                | 5611905       | \$104     |           |
| CONVERSION KIT LP TO NAT. DXL-150                |                 |             |             |                 |                | 5611906       | \$104     |           |
| CONVERSION KIT LP TO NAT. DXL-170                |                 |             |             |                 |                | 5611905       | \$104     |           |
| CONVERSION KIT LP TO NAT. DXL-200                |                 |             |             |                 |                | 5611908       | \$106     |           |
| FILL-TROL #110 FOR WATER BOILERS 150 MBH OR LESS |                 |             |             |                 |                | 14624002      | \$291     |           |
| FILL-TROL #111 FOR WATER BOILERS OVER 150 MBH    |                 |             |             |                 |                | 14624003      | \$392     |           |

**DXL - STANDARD EQUIPMENT**

**STANDARD EQUIPMENT:**

- Boiler Control Module: Recessed Fuel Smart Hydrostat Temperature Limit, LWCO and Boiler Reset Control with Circulator Relay and Domestic Hot Water Input Override.
- User Display Interface: Temperature LED display with dial-type settings and diagnostic indicator lights.
- Heat Exchanger: Cast Iron Sections with Cast Iron Push Nipples.
- Combustion: Completely Installed and Wired Gas Control System with Burners and Manifold consisting of Stainless Steel Burners, Automatic Redundant Combination Gas Valve, 24 Volt Intermittent Pilot Control, Continuous Retry 100% Shut-Off, Combination Pilot Burner/Electrode/Sensor.
- Electrical: 24v Transformer
- Safety: Flame Roll-Out Safety Shut-Off and Manual Reset Blocked Vent Safety Shut-Off.
- Other: Boiler Jacket, Integral Draft Diverter, Combination Temperature/Pressure Gauge, Circulator Pump, 3/4" Drain Valve,

**XEB SERIES II**

NATURAL OR PROPANE  
HOT WATER BOILER  
INDUCED DRAFT  
(CHIMNEY/SIDEWALL VENTED)



Tested for 50 psi. ASME  
Working Pressure

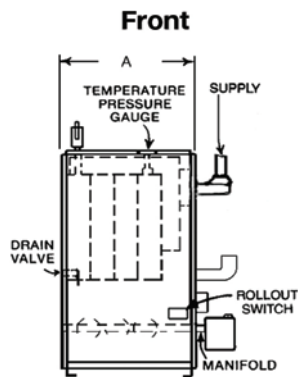

**Left Side**

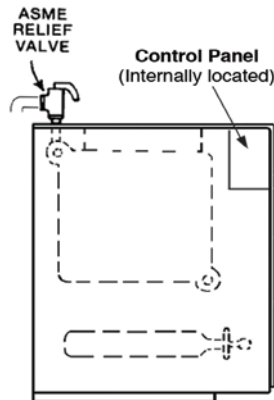

**Right Side**

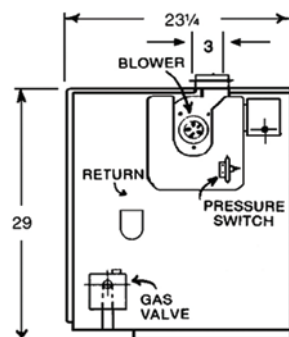

**General Information** (See IOM for complete instructions)

| Clearances | Combustible Materials (Required) (1)         |              |
|------------|----------------------------------------------|--------------|
|            | (1) Required distances measured from boiler. | Top          |
|            | Rear                                         | 6" (152 mm)  |
|            | Right Side                                   | 8" (203 mm)  |
|            | Opposite Side                                | 6" (152 mm)  |
|            | Front (Alcove)*                              | 18" (457 mm) |
|            | Flue Connector                               | 6" (152 mm)  |

\*Definition of Alcove is three sided space with no wall in front of boiler. ANSI standard for alcove is 18 inches from appliance to leading edge of side walls as shown in IOM.

| Connections   | Return/Supply Water                                                                                                                | Gas In   |
|---------------|------------------------------------------------------------------------------------------------------------------------------------|----------|
| All Models    | 1-1/4" NPT                                                                                                                         | 1/2" NPT |
| Electrical    | 120 Volts AC, 60 hertz, 1 phase, Less than 12 amps (15 amp circuit recommended)                                                    |          |
| Water Content | XEB-2 - 1.75 Gallons, XEB-3 - 3.00 Gallons, XEB-4 - 4.25 Gallons, XEB-5 - 5.50 Gallons, XEB-6 - 6.75 Gallons, XEB-7 - 8.00 Gallons |          |

**Dimensions**

| Model | A "Width" | B "Height" | C "Depth" |
|-------|-----------|------------|-----------|
| XEB-2 | 11"       | 29"        | 23-1/4"   |
| XEB-3 | 14-1/4"   | 29"        | 23-1/4"   |
| XEB-4 | 17-1/2"   | 29"        | 23-1/4"   |
| XEB-5 | 20-3/4"   | 29"        | 23-1/4"   |
| XEB-6 | 24"       | 29"        | 23-1/4"   |
| XEB-7 | 27-1/4"   | 29"        | 23-1/4"   |

| XEB SERIES II CONTINUED                                  |                 |             |             |                 |                |               |                          |                    |           |
|----------------------------------------------------------|-----------------|-------------|-------------|-----------------|----------------|---------------|--------------------------|--------------------|-----------|
| (NATURAL GAS - LESS SYSTEM PUMP)                         |                 |             |             |                 |                |               |                          |                    |           |
| BOILER MODEL                                             | ITEM NUMBER     | TRADE PRICE | INPUT (MBH) | HTG. CAP. (MBH) | AHRI NET (MBH) | AFUE RATING % | CHIMNEY CAT. I Min. Size | SIDE-WALL CAT. III | SHIP WGT. |
| XEB-2                                                    | XEB204203100203 | \$2,016     | 42.5        | 36              | 31             | 84.4          | 4"                       | 3"                 | 215       |
| XEB-3                                                    | XEB307503100203 | \$2,281     | 75.0        | 63              | 55             | 83.4          | 4"                       | 3"                 | 265       |
| XEB-4                                                    | XEB411203100203 | \$2,520     | 112.5       | 94              | 82             | 83.0          | 4"                       | 3"                 | 322       |
| XEB-5                                                    | XEB515003100203 | \$2,832     | 150.0       | 125             | 109            | 82.7          | 4"                       | 3"                 | 370       |
| XEB-6                                                    | XEB618703100203 | \$3,330     | 187.5       | 155             | 135            | 82.3          | 4"                       | 4"                 | 431       |
| XEB-7                                                    | XEB722503100203 | \$3,656     | 225.0       | 186             | 162            | 82.0          | 4"                       | 4"                 | 480       |
| (NATURAL GAS - WITH TACO SYSTEM PUMP)                    |                 |             |             |                 |                |               |                          |                    |           |
| BOILER MODEL                                             | ITEM NUMBER     | TRADE PRICE | INPUT (MBH) | HTG. CAP. (MBH) | AHRI NET (MBH) | AFUE RATING % | CHIMNEY CAT. I Min. Size | SIDE-WALL CAT. III | SHIP WGT. |
| XEB-2                                                    | XEB204203110203 | \$2,086     | 42.5        | 36              | 31             | 84.4          | 4"                       | 3"                 | 215       |
| XEB-3                                                    | XEB307503110203 | \$2,351     | 75.0        | 63              | 55             | 83.4          | 4"                       | 3"                 | 265       |
| XEB-4                                                    | XEB411203110203 | \$2,591     | 112.5       | 94              | 82             | 83.0          | 4"                       | 3"                 | 322       |
| XEB-5                                                    | XEB515003110203 | \$2,902     | 150.0       | 125             | 109            | 82.7          | 4"                       | 3"                 | 370       |
| XEB-6                                                    | XEB618703110203 | \$3,401     | 187.5       | 155             | 135            | 82.3          | 4"                       | 4"                 | 431       |
| XEB-7                                                    | XEB722503110203 | \$3,726     | 225.0       | 186             | 162            | 82.0          | 4"                       | 4"                 | 480       |
| (NATURAL GAS, HIGH ALTITUDE - WITH TACO SYSTEM PUMP)     |                 |             |             |                 |                |               |                          |                    |           |
| BOILER MODEL                                             | ITEM NUMBER     | TRADE PRICE | INPUT (MBH) | HTG. CAP. (MBH) | AHRI NET (MBH) | AFUE RATING % | CHIMNEY CAT. I Min. Size | SIDE-WALL CAT. III | SHIP WGT. |
| XEB-2                                                    | XEB204203112203 | \$2,086     | 42.5        | 36              | 31             | 84.4          | 4"                       | 3"                 | 215       |
| XEB-3                                                    | XEB307503112203 | \$2,351     | 75.0        | 63              | 55             | 83.4          | 4"                       | 3"                 | 265       |
| XEB-4                                                    | XEB411203112203 | \$2,591     | 112.5       | 94              | 82             | 83.0          | 4"                       | 3"                 | 322       |
| XEB-5                                                    | XEB515003112203 | \$2,902     | 150.0       | 125             | 109            | 82.7          | 4"                       | 3"                 | 370       |
| XEB-6                                                    | XEB618703112203 | \$3,401     | 187.5       | 155             | 135            | 82.3          | 4"                       | 4"                 | 431       |
| XEB-7                                                    | XEB722503112203 | \$3,726     | 225.0       | 186             | 162            | 82.0          | 4"                       | 4"                 | 480       |
| (NATURAL GAS - WITH GRUNDFOS SYSTEM PUMP)                |                 |             |             |                 |                |               |                          |                    |           |
| BOILER MODEL                                             | ITEM NUMBER     | TRADE PRICE | INPUT (MBH) | HTG. CAP. (MBH) | AHRI NET (MBH) | AFUE RATING % | CHIMNEY CAT. I Min. Size | SIDE-WALL CAT. III | SHIP WGT. |
| XEB-2                                                    | XEB204203120203 | \$2,086     | 42.5        | 36              | 31             | 84.4          | 4"                       | 3"                 | 215       |
| XEB-3                                                    | XEB307503120203 | \$2,351     | 75.0        | 63              | 55             | 83.4          | 4"                       | 3"                 | 265       |
| XEB-4                                                    | XEB411203120203 | \$2,591     | 112.5       | 94              | 82             | 83.0          | 4"                       | 3"                 | 322       |
| XEB-5                                                    | XEB515003120203 | \$2,902     | 150.0       | 125             | 109            | 82.7          | 4"                       | 3"                 | 370       |
| XEB-6                                                    | XEB618703120203 | \$3,401     | 187.5       | 155             | 135            | 82.3          | 4"                       | 4"                 | 431       |
| XEB-7                                                    | XEB722503120203 | \$3,726     | 225.0       | 186             | 162            | 82.0          | 4"                       | 4"                 | 480       |
| (NATURAL GAS, HIGH ALTITUDE - WITH GRUNDFOS SYSTEM PUMP) |                 |             |             |                 |                |               |                          |                    |           |
| BOILER MODEL                                             | ITEM NUMBER     | TRADE PRICE | INPUT (MBH) | HTG. CAP. (MBH) | AHRI NET (MBH) | AFUE RATING % | CHIMNEY CAT. I Min. Size | SIDE-WALL CAT. III | SHIP WGT. |
| XEB-2                                                    | XEB204203122203 | \$2,086     | 42.5        | 36              | 31             | 84.4          | 4"                       | 3"                 | 215       |
| XEB-3                                                    | XEB307503122203 | \$2,351     | 75.0        | 63              | 55             | 83.4          | 4"                       | 3"                 | 265       |
| XEB-4                                                    | XEB411203122203 | \$2,591     | 112.5       | 94              | 82             | 83.0          | 4"                       | 3"                 | 322       |
| XEB-5                                                    | XEB515003122203 | \$2,902     | 150.0       | 125             | 109            | 82.7          | 4"                       | 3"                 | 370       |
| XEB-6                                                    | XEB618703122203 | \$3,401     | 187.5       | 155             | 135            | 82.3          | 4"                       | 4"                 | 431       |
| XEB-7                                                    | XEB722503122203 | \$3,726     | 225.0       | 186             | 162            | 82.0          | 4"                       | 4"                 | 480       |

| XEB SERIES II CONTINUED                |                 |             |             |                 |                |               |                          |                    |           |
|----------------------------------------|-----------------|-------------|-------------|-----------------|----------------|---------------|--------------------------|--------------------|-----------|
| (NATURAL GAS - WITH B & G SYSTEM PUMP) |                 |             |             |                 |                |               |                          |                    |           |
| BOILER MODEL                           | ITEM NUMBER     | TRADE PRICE | INPUT (MBH) | HTG. CAP. (MBH) | AHRI NET (MBH) | AFUE RATING % | CHIMNEY CAT. I Min. Size | SIDE-WALL CAT. III | SHIP WGT. |
| XEB-2                                  | XEB204203130203 | \$2,086     | 42.5        | 36              | 31             | 84.4          | 4"                       | 3"                 | 215       |
| XEB-3                                  | XEB307503130203 | \$2,351     | 75.0        | 63              | 55             | 83.4          | 4"                       | 3"                 | 265       |
| XEB-4                                  | XEB411203130203 | \$2,591     | 112.5       | 94              | 82             | 83.0          | 4"                       | 3"                 | 322       |
| XEB-5                                  | XEB515003130203 | \$2,902     | 150.0       | 125             | 109            | 82.7          | 4"                       | 3"                 | 370       |
| XEB-6                                  | XEB618703130203 | \$3,401     | 187.5       | 155             | 135            | 82.3          | 4"                       | 4"                 | 431       |
| XEB-7                                  | XEB722503130203 | \$3,726     | 225.0       | 186             | 162            | 82.0          | 4"                       | 4"                 | 480       |
| (LP GAS - LESS SYSTEM PUMP)            |                 |             |             |                 |                |               |                          |                    |           |
| BOILER MODEL                           | ITEM NUMBER     | TRADE PRICE | INPUT (MBH) | HTG. CAP. (MBH) | AHRI NET (MBH) | AFUE RATING % | CHIMNEY CAT. I Min. Size | SIDE-WALL CAT. III | SHIP WGT. |
| XEB-2                                  | XEB204213100203 | \$2,064     | 42.5        | 36              | 31             | 84.4          | 4"                       | 3"                 | 215       |
| XEB-3                                  | XEB307513100203 | \$2,331     | 75.0        | 63              | 55             | 83.4          | 4"                       | 3"                 | 265       |
| XEB-4                                  | XEB411213100203 | \$2,569     | 112.5       | 94              | 82             | 83.0          | 4"                       | 3"                 | 322       |
| XEB-5                                  | XEB515013100203 | \$2,880     | 150.0       | 125             | 109            | 82.7          | 4"                       | 3"                 | 370       |
| XEB-6                                  | XEB618713100203 | \$3,380     | 187.5       | 155             | 135            | 82.3          | 4"                       | 4"                 | 431       |
| XEB-7                                  | XEB722513100203 | \$3,706     | 225.0       | 186             | 162            | 82.0          | 4"                       | 4"                 | 480       |
| (LP GAS - WITH TACO SYSTEM PUMP)       |                 |             |             |                 |                |               |                          |                    |           |
| BOILER MODEL                           | ITEM NUMBER     | TRADE PRICE | INPUT (MBH) | HTG. CAP. (MBH) | AHRI NET (MBH) | AFUE RATING % | CHIMNEY CAT. I Min. Size | SIDE-WALL CAT. III | SHIP WGT. |
| XEB-2                                  | XEB204213110203 | \$2,135     | 42.5        | 36              | 31             | 84.4          | 4"                       | 3"                 | 215       |
| XEB-3                                  | XEB307513110203 | \$2,401     | 75.0        | 63              | 55             | 83.4          | 4"                       | 3"                 | 265       |
| XEB-4                                  | XEB411213110203 | \$2,640     | 112.5       | 94              | 82             | 83.0          | 4"                       | 3"                 | 322       |
| XEB-5                                  | XEB515013110203 | \$2,951     | 150.0       | 125             | 109            | 82.7          | 4"                       | 3"                 | 370       |
| XEB-6                                  | XEB618713110203 | \$3,451     | 187.5       | 155             | 135            | 82.3          | 4"                       | 4"                 | 431       |
| XEB-7                                  | XEB722513110203 | \$3,776     | 225.0       | 186             | 162            | 82.0          | 4"                       | 4"                 | 480       |
| (LP GAS - WITH GRUNDFOS SYSTEM PUMP)   |                 |             |             |                 |                |               |                          |                    |           |
| BOILER MODEL                           | ITEM NUMBER     | TRADE PRICE | INPUT (MBH) | HTG. CAP. (MBH) | AHRI NET (MBH) | AFUE RATING % | CHIMNEY CAT. I Min. Size | SIDE-WALL CAT. III | SHIP WGT. |
| XEB-2                                  | XEB204213120203 | \$2,135     | 42.5        | 36              | 31             | 84.4          | 4"                       | 3"                 | 215       |
| XEB-3                                  | XEB307513120203 | \$2,401     | 75.0        | 63              | 55             | 83.4          | 4"                       | 3"                 | 265       |
| XEB-4                                  | XEB411213120203 | \$2,640     | 112.5       | 94              | 82             | 83.0          | 4"                       | 3"                 | 322       |
| XEB-5                                  | XEB515013120203 | \$2,951     | 150.0       | 125             | 109            | 82.7          | 4"                       | 3"                 | 370       |
| XEB-6                                  | XEB618713120203 | \$3,451     | 187.5       | 155             | 135            | 82.3          | 4"                       | 4"                 | 431       |
| XEB-7                                  | XEB722513120203 | \$3,776     | 225.0       | 186             | 162            | 82.0          | 4"                       | 4"                 | 480       |
| (LP GAS - WITH B & G SYSTEM PUMP)      |                 |             |             |                 |                |               |                          |                    |           |
| BOILER MODEL                           | ITEM NUMBER     | TRADE PRICE | INPUT (MBH) | HTG. CAP. (MBH) | AHRI NET (MBH) | AFUE RATING % | CHIMNEY CAT. I Min. Size | SIDE-WALL CAT. III | SHIP WGT. |
| XEB-2                                  | XEB204213130203 | \$2,135     | 42.5        | 36              | 31             | 84.4          | 4"                       | 3"                 | 215       |
| XEB-3                                  | XEB307513130203 | \$2,401     | 75.0        | 63              | 55             | 83.4          | 4"                       | 3"                 | 265       |
| XEB-4                                  | XEB411213130203 | \$2,640     | 112.5       | 94              | 82             | 83.0          | 4"                       | 3"                 | 322       |
| XEB-5                                  | XEB515013130203 | \$2,951     | 150.0       | 125             | 109            | 82.7          | 4"                       | 3"                 | 370       |
| XEB-6                                  | XEB618713130203 | \$3,451     | 187.5       | 155             | 135            | 82.3          | 4"                       | 4"                 | 431       |
| XEB-7                                  | XEB722513130203 | \$3,776     | 225.0       | 186             | 162            | 82.0          | 4"                       | 4"                 | 480       |



| <b>XEB SERIES II CONTINUED</b>                                                                                                                                                                                                                                                                                                                                                                                                                                                                                                                                                                                                                                                                                                                                                                                                                                                                                                                                                      |                  |              |
|-------------------------------------------------------------------------------------------------------------------------------------------------------------------------------------------------------------------------------------------------------------------------------------------------------------------------------------------------------------------------------------------------------------------------------------------------------------------------------------------------------------------------------------------------------------------------------------------------------------------------------------------------------------------------------------------------------------------------------------------------------------------------------------------------------------------------------------------------------------------------------------------------------------------------------------------------------------------------------------|------------------|--------------|
| <b>(USE PARTS MULTIPLIER FOR ALL OF THE FOLLOWING)</b>                                                                                                                                                                                                                                                                                                                                                                                                                                                                                                                                                                                                                                                                                                                                                                                                                                                                                                                              | <b>PN</b>        | <b>TRADE</b> |
| <b>XEB NATURAL GAS TO LP CONVERSION KIT (ALL SIZES)</b>                                                                                                                                                                                                                                                                                                                                                                                                                                                                                                                                                                                                                                                                                                                                                                                                                                                                                                                             | <b>550002722</b> | <b>\$82</b>  |
| <b>XEB LP GAS TO NATURAL GAS CONVERSION KIT (ALL SIZES)</b>                                                                                                                                                                                                                                                                                                                                                                                                                                                                                                                                                                                                                                                                                                                                                                                                                                                                                                                         | <b>43300660</b>  | <b>\$90</b>  |
| <b>COMBUSTIBLE FLOOR PLATE FOR ALL CAPACITIES</b>                                                                                                                                                                                                                                                                                                                                                                                                                                                                                                                                                                                                                                                                                                                                                                                                                                                                                                                                   | <b>14614032</b>  | <b>\$96</b>  |
| <b>4" THIMBLE (SIMPSON #915295)</b>                                                                                                                                                                                                                                                                                                                                                                                                                                                                                                                                                                                                                                                                                                                                                                                                                                                                                                                                                 | <b>14629014</b>  | <b>\$40</b>  |
| <b>TJERNLUND VH-1-3" SIDE WALL VENT HOOD (XEB-2 TO XEB-5)</b>                                                                                                                                                                                                                                                                                                                                                                                                                                                                                                                                                                                                                                                                                                                                                                                                                                                                                                                       | <b>14629010</b>  | <b>\$229</b> |
| <b>TJERNLUND VH-1-3" SIDE WALL VENT HOOD (XEB-6 TO XEB-7)</b>                                                                                                                                                                                                                                                                                                                                                                                                                                                                                                                                                                                                                                                                                                                                                                                                                                                                                                                       | <b>14629011</b>  | <b>\$274</b> |
| <b>FILL-TROL #110 FOR WATER BOILERS 150 MBH OR LESS</b>                                                                                                                                                                                                                                                                                                                                                                                                                                                                                                                                                                                                                                                                                                                                                                                                                                                                                                                             | <b>14624002</b>  | <b>\$291</b> |
| <b>FILL-TROL #111 FOR WATER BOILERS OVER 150 MBH</b>                                                                                                                                                                                                                                                                                                                                                                                                                                                                                                                                                                                                                                                                                                                                                                                                                                                                                                                                | <b>14624003</b>  | <b>\$392</b> |
| <b>XEB (Series II) - STANDARD EQUIPMENT</b>                                                                                                                                                                                                                                                                                                                                                                                                                                                                                                                                                                                                                                                                                                                                                                                                                                                                                                                                         |                  |              |
| <b><u>STANDARD EQUIPMENT:</u></b>                                                                                                                                                                                                                                                                                                                                                                                                                                                                                                                                                                                                                                                                                                                                                                                                                                                                                                                                                   |                  |              |
| <ul style="list-style-type: none"> <li>- Boiler Control Module: Recessed Honeywell Control (High Limit/Electronic Ignition Control).</li> <li>- User Display Interface: Digital Temperature Display.</li> <li>- Heat Exchanger: Cast Iron Sections with Cast Iron Push Nipples.</li> <li>- Combustion: Completely Installed and Wired Gas Control System with Titanium Composite Burners and Manifold consisting of: Automatic Redundant Combination Gas Valve, 24 Volt Intermittent Pilot Control, Continuous Retry 100% Shut Off, Combination Pilot Burner/Electrode/Flame Sensor.</li> <li>- Electrical: 24 Volt Transformer, Service Switch.</li> <li>- Safety: Flame Roll-Out Safety Shut-Off (Fuse Link) and Pressure Switch (vent safety shutoff) with Spare Fuse Link included.</li> <li>- Other: Assembled Boiler with Insulated Jacket, Induced Draft Fan, Combination Temperature/Pressure Gauge, Circulator Pump, 3/4" Drain Valve, 30lb. ASME Relief Valve.</li> </ul> |                  |              |

**WPSB SERIES II**

NATURAL OR PROPANE  
HOT WATER BOILER  
(INTEGRAL DRAFT DIVERTER)



Tested for 50 psi  
ASME Working Pressure

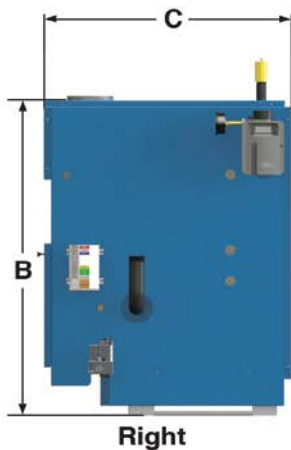
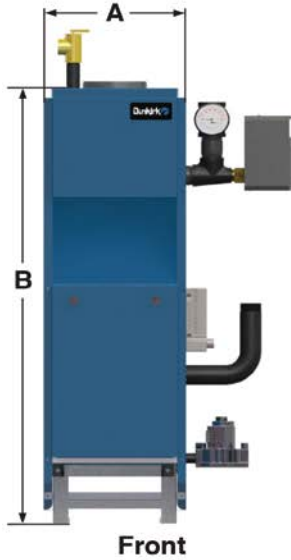

**General Information** (See IOM for complete instructions)

| Clearances                                   |                       | Combustible Materials |
|----------------------------------------------|-----------------------|-----------------------|
|                                              |                       | (Required) (1)        |
| (1) Required distances measured from boiler. | <b>Top</b>            | 6" (152 mm)           |
|                                              | <b>Rear</b>           | 6" (152 mm)           |
|                                              | <b>Control Side</b>   | 7" (178 mm)           |
|                                              | <b>Opposite Side</b>  | 6" (152 mm)           |
|                                              | <b>Front(Alcove)*</b> | 18" (457 mm)          |
|                                              | <b>Flue Connector</b> | 6" (152 mm)           |

\*Definition of Alcove is three sided space with no wall in front of boiler. ANSI standard for alcove is 18 inches from appliance to leading edge of side walls as shown in IOM.

| Connections          | Return/Supply Water                                                                                                                                          | Gas In   |
|----------------------|--------------------------------------------------------------------------------------------------------------------------------------------------------------|----------|
| <b>All Models</b>    | 1-1/4" NPT                                                                                                                                                   | 1/2" NPT |
| <b>Electrical</b>    | 120 Volts AC, 60 hertz, 1 phase, Less than 12 amps (15 amp circuit recommended)                                                                              |          |
| <b>Water Content</b> | WPSB-3 - 6.3 Gallons, WPSB-4 - 8.1 Gallons, WPSB-5 - 9.9 Gallons, WPSB-6 - 11.7 Gallons, WPSB-7 - 13.5 Gallons, WPSB-8 - 15.3 Gallons, WPSB-9 - 17.2 Gallons |          |

**Dimensions** (Note: Add 5 1/2" to height for Vent Damper).

| Model  | A "Width" | B "Height" | C "Depth" |
|--------|-----------|------------|-----------|
| WPSB-3 | 11-1/4"   | 36-3/8"    | 26-1/2"   |
| WPSB-4 | 14-1/2"   | 36-3/8"    | 26-1/2"   |
| WPSB-5 | 17-3/4"   | 36-3/8"    | 26-1/2"   |
| WPSB-6 | 21"       | 36-3/8"    | 26-1/2"   |
| WPSB-7 | 24-1/4"   | 36-3/8"    | 26-1/2"   |
| WPSB-8 | 27-1/2"   | 36-3/8"    | 26-1/2"   |
| WPSB-9 | 30-3/4"   | 36-3/8"    | 26-1/2"   |

| WPSB SERIES II CONTINUED                             |                 |             |             |                 |                |               |           |           |
|------------------------------------------------------|-----------------|-------------|-------------|-----------------|----------------|---------------|-----------|-----------|
| (NATURAL GAS - LESS SYSTEM PUMP)                     |                 |             |             |                 |                |               |           |           |
| BOILER MODEL                                         | ITEM NUMBER     | TRADE PRICE | INPUT (MBH) | HTG. CAP. (MBH) | AHRI NET (MBH) | AFUE RATING % | FLUE DIA. | SHIP WGT. |
| WPSB-3D                                              | WPS307503200203 | \$2,310     | 75          | 63              | 55             | 84.0          | 5"        | 315       |
| WPSB-4D                                              | WPS411203200203 | \$2,563     | 112.5       | 94              | 82             | 84.0          | 6"        | 377       |
| WPSB-5D                                              | WPS515003200203 | \$2,828     | 150         | 126             | 110            | 84.1          | 6"        | 453       |
| WPSB-6D                                              | WPS618703200203 | \$3,175     | 187.5       | 157             | 137            | 84.1          | 7"        | 534       |
| WPSB-7D                                              | WPS722503200203 | \$3,474     | 225         | 188             | 163            | 84.0          | 7"        | 601       |
| WPSB-8D                                              | WPS826203200203 | \$3,745     | 262.5       | 220             | 191            | 83.9          | 7"        | 665       |
| WPSB-9D                                              | WPS929903200203 | \$4,329     | 299         | 251             | 218            | 83.7          | 7"        | 750       |
| (NATURAL GAS - WITH TACO SYSTEM PUMP)                |                 |             |             |                 |                |               |           |           |
| BOILER MODEL                                         | ITEM NUMBER     | TRADE PRICE | INPUT (MBH) | HTG. CAP. (MBH) | AHRI NET (MBH) | AFUE RATING % | FLUE DIA. | SHIP WGT. |
| WPSB-3D                                              | WPS307503210203 | \$2,381     | 75          | 63              | 55             | 84.0          | 5"        | 315       |
| WPSB-4D                                              | WPS411203210203 | \$2,634     | 112.5       | 94              | 82             | 84.0          | 6"        | 377       |
| WPSB-5D                                              | WPS515003210203 | \$2,899     | 150         | 126             | 110            | 84.1          | 6"        | 453       |
| WPSB-6D                                              | WPS618703210203 | \$3,246     | 187.5       | 157             | 137            | 84.1          | 7"        | 534       |
| WPSB-7D                                              | WPS722503210203 | \$3,545     | 225         | 188             | 163            | 84.0          | 7"        | 601       |
| WPSB-8D                                              | WPS826203210203 | \$3,816     | 262.5       | 220             | 191            | 83.9          | 7"        | 665       |
| WPSB-9D                                              | WPS929903210203 | \$4,399     | 299         | 251             | 218            | 83.7          | 7"        | 750       |
| (NATURAL GAS, HIGH ALTITUDE - WITH TACO SYSTEM PUMP) |                 |             |             |                 |                |               |           |           |
| BOILER MODEL                                         | ITEM NUMBER     | TRADE PRICE | INPUT (MBH) | HTG. CAP. (MBH) | AHRI NET (MBH) | AFUE RATING % | FLUE DIA. | SHIP WGT. |
| WPSB-3D                                              | WPS307503212203 | \$2,381     | 75          | 63              | 55             | 84.0          | 5"        | 315       |
| WPSB-4D                                              | WPS411203212203 | \$2,634     | 112.5       | 94              | 82             | 84.0          | 6"        | 377       |
| WPSB-5D                                              | WPS515003212203 | \$2,899     | 150         | 126             | 110            | 84.1          | 6"        | 453       |
| WPSB-6D                                              | WPS618703212203 | \$3,246     | 187.5       | 157             | 137            | 84.1          | 7"        | 534       |
| WPSB-7D                                              | WPS722503212203 | \$3,545     | 225         | 188             | 163            | 84.0          | 7"        | 601       |
| WPSB-8D                                              | WPS826203212203 | \$3,816     | 262.5       | 220             | 191            | 83.9          | 7"        | 665       |
| WPSB-9D                                              | WPS929903212203 | \$4,399     | 299         | 251             | 218            | 83.7          | 7"        | 750       |
| (NATURAL GAS - WITH GRUNDFOS SYSTEM PUMP)            |                 |             |             |                 |                |               |           |           |
| BOILER MODEL                                         | ITEM NUMBER     | TRADE PRICE | INPUT (MBH) | HTG. CAP. (MBH) | AHRI NET (MBH) | AFUE RATING % | FLUE DIA. | SHIP WGT. |
| WPSB-3D                                              | WPS307503220203 | \$2,381     | 75          | 63              | 55             | 84.0          | 5"        | 315       |
| WPSB-4D                                              | WPS411203220203 | \$2,634     | 112.5       | 94              | 82             | 84.0          | 6"        | 377       |
| WPSB-5D                                              | WPS515003220203 | \$2,899     | 150         | 126             | 110            | 84.1          | 6"        | 453       |
| WPSB-6D                                              | WPS618703220203 | \$3,246     | 187.5       | 157             | 137            | 84.1          | 7"        | 534       |
| WPSB-7D                                              | WPS722503220203 | \$3,545     | 225         | 188             | 163            | 84.0          | 7"        | 601       |
| WPSB-8D                                              | WPS826203220203 | \$3,816     | 262.5       | 220             | 191            | 83.9          | 7"        | 665       |
| WPSB-9D                                              | WPS929903220203 | \$4,399     | 299         | 251             | 218            | 83.7          | 7"        | 750       |

| WPSB SERIES II SERIES CONTINUED        |                 |             |             |                 |                |               |           |           |
|----------------------------------------|-----------------|-------------|-------------|-----------------|----------------|---------------|-----------|-----------|
| (NATURAL GAS - WITH B & G SYSTEM PUMP) |                 |             |             |                 |                |               |           |           |
| BOILER MODEL                           | ITEM NUMBER     | TRADE PRICE | INPUT (MBH) | HTG. CAP. (MBH) | AHRI NET (MBH) | AFUE RATING % | FLUE DIA. | SHIP WGT. |
| WPSB-3D                                | WPS307503230203 | \$2,381     | 75          | 63              | 55             | 84.0          | 5"        | 315       |
| WPSB-4D                                | WPS411203230203 | \$2,634     | 112.5       | 94              | 82             | 84.0          | 6"        | 377       |
| WPSB-5D                                | WPS515003230203 | \$2,899     | 150         | 126             | 110            | 84.1          | 6"        | 453       |
| WPSB-6D                                | WPS618703230203 | \$3,246     | 187.5       | 157             | 137            | 84.1          | 7"        | 534       |
| WPSB-7D                                | WPS722503230203 | \$3,545     | 225         | 188             | 163            | 84.0          | 7"        | 601       |
| WPSB-8D                                | WPS826203230203 | \$3,816     | 262.5       | 220             | 191            | 83.9          | 7"        | 665       |
| WPSB-9D                                | WPS929903230203 | \$4,399     | 299         | 251             | 218            | 83.7          | 7"        | 750       |
| (LP GAS - LESS SYSTEM PUMP)            |                 |             |             |                 |                |               |           |           |
| BOILER MODEL                           | ITEM NUMBER     | TRADE PRICE | INPUT (MBH) | HTG. CAP. (MBH) | AHRI NET (MBH) | AFUE RATING % | FLUE DIA. | SHIP WGT. |
| WPSB-3D                                | WPS307513200203 | \$2,359     | 70          | 59              | 51             | 84.0          | 5"        | 315       |
| WPSB-4D                                | WPS411213200203 | \$2,613     | 105         | 88              | 77             | 84.0          | 6"        | 377       |
| WPSB-5D                                | WPS515013200203 | \$2,877     | 140         | 118             | 103            | 84.1          | 6"        | 453       |
| WPSB-6D                                | WPS618713200203 | \$3,224     | 175         | 147             | 128            | 84.1          | 7"        | 534       |
| WPSB-7D                                | WPS722513200203 | \$3,524     | 210         | 176             | 153            | 84.0          | 7"        | 601       |
| WPSB-8D                                | WPS826213200203 | \$3,794     | 245         | 206             | 179            | 83.9          | 7"        | 665       |
| WPSB-9D                                | WPS929913200203 | \$4,378     | 280         | 235             | 204            | 83.7          | 7"        | 750       |
| (LP GAS - WITH TACO SYSTEM PUMP)       |                 |             |             |                 |                |               |           |           |
| BOILER MODEL                           | ITEM NUMBER     | TRADE PRICE | INPUT (MBH) | HTG. CAP. (MBH) | AHRI NET (MBH) | AFUE RATING % | FLUE DIA. | SHIP WGT. |
| WPSB-3D                                | WPS307513210203 | \$2,430     | 70          | 59              | 51             | 84.0          | 5"        | 315       |
| WPSB-4D                                | WPS411213210203 | \$2,684     | 105         | 88              | 77             | 84.0          | 6"        | 377       |
| WPSB-5D                                | WPS515013210203 | \$2,948     | 140         | 118             | 103            | 84.1          | 6"        | 453       |
| WPSB-6D                                | WPS618713210203 | \$3,295     | 175         | 147             | 128            | 84.1          | 7"        | 534       |
| WPSB-7D                                | WPS722513210203 | \$3,594     | 210         | 176             | 153            | 84.0          | 7"        | 601       |
| WPSB-8D                                | WPS826213210203 | \$3,865     | 245         | 206             | 179            | 83.9          | 7"        | 665       |
| WPSB-9D                                | WPS929913210203 | \$4,448     | 280         | 235             | 204            | 83.7          | 7"        | 750       |
| (LP GAS - WITH GRUNDFOS SYSTEM PUMP)   |                 |             |             |                 |                |               |           |           |
| BOILER MODEL                           | ITEM NUMBER     | TRADE PRICE | INPUT (MBH) | HTG. CAP. (MBH) | AHRI NET (MBH) | AFUE RATING % | FLUE DIA. | SHIP WGT. |
| WPSB-3D                                | WPS307513220203 | \$2,430     | 70          | 59              | 51             | 84.0          | 5"        | 315       |
| WPSB-4D                                | WPS411213220203 | \$2,684     | 105         | 88              | 77             | 84.0          | 6"        | 377       |
| WPSB-5D                                | WPS515013220203 | \$2,948     | 140         | 118             | 103            | 84.1          | 6"        | 453       |
| WPSB-6D                                | WPS618713220203 | \$3,295     | 175         | 147             | 128            | 84.1          | 7"        | 534       |
| WPSB-7D                                | WPS722513220203 | \$3,594     | 210         | 176             | 153            | 84.0          | 7"        | 601       |
| WPSB-8D                                | WPS826213220203 | \$3,865     | 245         | 206             | 179            | 83.9          | 7"        | 665       |
| WPSB-9D                                | WPS929913220203 | \$4,448     | 280         | 235             | 204            | 83.7          | 7"        | 750       |

| WPSB SERIES II SERIES CONTINUED                  |                 |             |             |                 |                |               |           |           |
|--------------------------------------------------|-----------------|-------------|-------------|-----------------|----------------|---------------|-----------|-----------|
| (LP GAS - WITH B & G SYSTEM PUMP)                |                 |             |             |                 |                |               |           |           |
| BOILER MODEL                                     | ITEM NUMBER     | TRADE PRICE | INPUT (MBH) | HTG. CAP. (MBH) | AHRI NET (MBH) | AFUE RATING % | FLUE DIA. | SHIP WGT. |
| WPSB-3D                                          | WPS307513230203 | \$2,430     | 70          | 59              | 51             | 84.0          | 5"        | 315       |
| WPSB-4D                                          | WPS411213230203 | \$2,684     | 105         | 88              | 77             | 84.0          | 6"        | 377       |
| WPSB-5D                                          | WPS515013230203 | \$2,948     | 140         | 118             | 103            | 84.1          | 6"        | 453       |
| WPSB-6D                                          | WPS618713230203 | \$3,295     | 175         | 147             | 128            | 84.1          | 7"        | 534       |
| WPSB-7D                                          | WPS722513230203 | \$3,594     | 210         | 176             | 153            | 84.0          | 7"        | 601       |
| WPSB-8D                                          | WPS826213230203 | \$3,865     | 245         | 206             | 179            | 83.9          | 7"        | 665       |
| WPSB-9D                                          | WPS929913230203 | \$4,448     | 280         | 235             | 204            | 83.7          | 7"        | 750       |
| (USE PARTS MULTIPLIER FOR ALL OF THE FOLLOWING)  |                 |             |             |                 |                | PN            | TRADE     |           |
| 3 SECTION NATURAL GAS TO LP GAS CONVERSION KIT   |                 |             |             |                 |                | 43300723      | \$50      |           |
| 4 SECTION NATURAL GAS TO LP GAS CONVERSION KIT   |                 |             |             |                 |                | 43300724      | \$50      |           |
| 5 SECTION NATURAL GAS TO LP GAS CONVERSION KIT   |                 |             |             |                 |                | 43300725      | \$50      |           |
| 6 SECTION NATURAL GAS TO LP GAS CONVERSION KIT   |                 |             |             |                 |                | 43300726      | \$59      |           |
| 7 SECTION NATURAL GAS TO LP GAS CONVERSION KIT   |                 |             |             |                 |                | 43300727      | \$59      |           |
| 8 SECTION NATURAL GAS TO LP GAS CONVERSION KIT   |                 |             |             |                 |                | 43300728      | \$59      |           |
| 9 SECTION NATURAL GAS TO LP GAS CONVERSION KIT   |                 |             |             |                 |                | 43300729      | \$59      |           |
| 4 SECTION LP GAS TO NATURAL GAS CONVERSION KIT   |                 |             |             |                 |                | 43300632      | \$130     |           |
| 5 SECTION LP GAS TO NATURAL GAS CONVERSION KIT   |                 |             |             |                 |                | 43300633      | \$130     |           |
| 6 SECTION LP GAS TO NATURAL GAS CONVERSION KIT   |                 |             |             |                 |                | 43300634      | \$130     |           |
| 7 SECTION LP GAS TO NATURAL GAS CONVERSION KIT   |                 |             |             |                 |                | 43300635      | \$130     |           |
| 8 SECTION LP GAS TO NATURAL GAS CONVERSION KIT   |                 |             |             |                 |                | 43300636      | \$130     |           |
| 9 SECTION LP GAS TO NATURAL GAS CONVERSION KIT   |                 |             |             |                 |                | 43300637      | \$155     |           |
| COMBUSTIBLE FLOOR PLATE FOR ALL CAPACITIES       |                 |             |             |                 |                | 14614032      | \$96      |           |
| FILL-TROL #110 FOR WATER BOILERS 150 MBH OR LESS |                 |             |             |                 |                | 14624002      | \$291     |           |
| FILL-TROL #111 FOR WATER BOILERS OVER 150 MBH    |                 |             |             |                 |                | 14624003      | \$392     |           |

**WPSB SERIES II - STANDARD EQUIPMENT**

**STANDARD EQUIPMENT:**

- Boiler Control Module: Fuel Smart Hydrostat Temperature Limit, LWCO and Boiler Reset Control with Circulator Relay and Domestic Hot Water Input Override.
- User Display Interface: Temperature LED Display with dial-type settings and diagnostic indicator lights
- Heat Exchanger: Cast Iron Sections with Cast Iron Push Nipples.
- Combustion: Completely Installed and Wired Gas Control System consisting of: Titanium Composite Burners, Gas Manifold with Orifices, Automatic Redundant Combination Gas Valve, 24 Volt with Pilot Filter and Regulator Intermittent Pilot Control, Continuous Retry 100% Shut Off, Combination Pilot Burner/Electrode/Flame Sensor.
- Safety: Flame Roll-Out Safety Shut-Off (Fuse Link) and Blocked Vent Safety Shut-Off Manual Reset Disc Thermostat (Spill Switch) with Spare Fuse Link included.
- Other: Assembled Boiler with Insulated Jacket, Integral Draft Diverter, Vent Damper, Combination Temperature/Pressure Gauge, Circulator Pump Wired with 5' Harness for Supply or Return Field Mounting, 3/4" Drain Valve, 30lb. ASME Relief Valve.

**PSB SERIES**

NATURAL OR PROPANE  
STEAM BOILER

15 psi  
MAWP

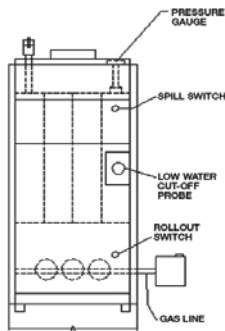

Front

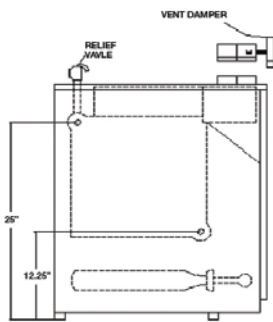

Left Side

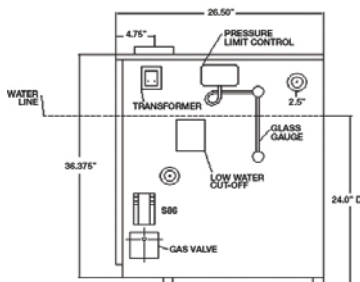

Right Side



**General Information** (See IOM for complete instructions)

| Clearances | Combustible Materials (Required) (1)         |             |
|------------|----------------------------------------------|-------------|
|            | (1) Required distances measured from boiler. | Top         |
|            | Rear                                         | 6" (152 mm) |
|            | Control Side                                 | 7" (178 mm) |
|            | Opposite Side                                | 6" (152 mm) |
|            | Front                                        | *Alcove     |
|            | Flue Connector                               | 6" (152 mm) |

\*Definition of Alcove is three sided space with no wall in front of boiler. ANSI standard for alcove is 18 inches from appliance to leading edge of side walls as shown in IOM.

| Connections | Supply      | Return          |
|-------------|-------------|-----------------|
|             |             | Two 2-1/2"      |
| Gas In      | 075/112/150 | 187/225/262/299 |
|             | 1/2" NPT    | 3/4" NPT        |

**Electrical** 120 Volts AC, 60 hertz, 1 phase, Less than 12 amps (15 amp circuit recommended)

| Dimensions |           |
|------------|-----------|
| Model      | A "Width" |
| PSB-3D     | 11-1/4"   |
| PSB-4D     | 14-1/2"   |
| PSB-5D     | 17-3/4"   |
| PSB-6D     | 21"       |
| PSB-7D     | 24-1/4"   |
| PSB-8D     | 27-1/2"   |
| PSB-9D     | 30-3/4"   |

| PSB SERIES CONTINUED |             |             |             |                 |                |                        |               |           |           |
|----------------------|-------------|-------------|-------------|-----------------|----------------|------------------------|---------------|-----------|-----------|
| (NATURAL GAS)        |             |             |             |                 |                |                        |               |           |           |
| BOILER MODEL         | ITEM NUMBER | TRADE PRICE | INPUT (MBH) | HTG. CAP. (MBH) | AHRI NET (MBH) | AHRI NET SQ. FT. STEAM | AFUE RATING % | FLUE DIA. | SHIP WGT. |
| PSB-3D               | 353001000   | \$2,644     | 75          | 62              | 47             | 196                    | 82.7          | 5"        | 297       |
| PSB-4D               | 354001000   | \$2,887     | 112         | 91              | 68             | 283                    | 82.0          | 6"        | 368       |
| PSB-5D               | 355001000   | \$3,253     | 150         | 122             | 92             | 383                    | 82.0          | 6"        | 440       |
| PSB-6D               | 356001000   | \$3,706     | 187         | 153             | 115            | 479                    | 82.0          | 7"        | 512       |
| PSB-7D               | 357001000   | \$4,087     | 225         | 183             | 137            | 571                    | 82.0          | 7"        | 584       |
| PSB-8D               | 358001000   | \$4,521     | 262         | 214             | 161            | 671                    | 82.0          | 7"        | 659       |
| PSB-9D               | 359001000   | \$4,760     | 299         | 245             | 184            | 767                    | 82.0          | 7"        | 736       |

(LP GAS)

| BOILER MODEL | ITEM NUMBER | TRADE PRICE | INPUT (MBH) | HTG. CAP. (MBH) | AHRI NET (MBH) | AHRI NET SQ. FT. STEAM | AFUE RATING % | FLUE DIA. | SHIP WGT. |
|--------------|-------------|-------------|-------------|-----------------|----------------|------------------------|---------------|-----------|-----------|
| PSB-3D       | 353004000   | \$2,693     | 70.0        | 58              | 44             | 183                    | 82.7          | 5"        | 297       |
| PSB-4D       | 354004000   | \$2,937     | 105.0       | 85              | 64             | 267                    | 80.4          | 6"        | 368       |
| PSB-5D       | 355004000   | \$3,302     | 140.0       | 114             | 86             | 358                    | 80.6          | 6"        | 440       |
| PSB-6D       | 356004000   | \$3,755     | 175.0       | 143             | 107            | 446                    | 80.9          | 7"        | 512       |
| PSB-7D       | 357004000   | \$4,136     | 210.0       | 171             | 128            | 533                    | 81.1          | 7"        | 584       |
| PSB-8D       | 358004000   | \$4,570     | 245.0       | 200             | 150            | 625                    | 81.3          | 7"        | 659       |
| PSB-9D       | 359004000   | \$4,809     | 280.0       | 229             | 172            | 717                    | 81.5          | 7"        | 736       |

(USE PARTS MULTIPLIER FOR ALL OF THE FOLLOWING)

|                                                     | PN       | TRADE |
|-----------------------------------------------------|----------|-------|
| 3 SECTION NATURAL GAS TO LP GAS CONVERSION KIT      | 43300723 | \$50  |
| 4 SECTION NATURAL GAS TO LP GAS CONVERSION KIT      | 43300724 | \$50  |
| 5 SECTION NATURAL GAS TO LP GAS CONVERSION KIT      | 43300725 | \$50  |
| 6 SECTION NATURAL GAS TO LP GAS CONVERSION KIT      | 43300726 | \$59  |
| 7 SECTION NATURAL GAS TO LP GAS CONVERSION KIT      | 43300727 | \$59  |
| 8 SECTION NATURAL GAS TO LP GAS CONVERSION KIT      | 43300728 | \$59  |
| 9 SECTION NATURAL GAS TO LP GAS CONVERSION KIT      | 43300729 | \$59  |
| 4 SECTION LP GAS TO NATURAL GAS CONVERSION KIT      | 43300632 | \$130 |
| 5 SECTION LP GAS TO NATURAL GAS CONVERSION KIT      | 43300633 | \$130 |
| 6 SECTION LP GAS TO NATURAL GAS CONVERSION KIT      | 43300634 | \$130 |
| 7 SECTION LP GAS TO NATURAL GAS CONVERSION KIT      | 43300635 | \$130 |
| 8 SECTION LP GAS TO NATURAL GAS CONVERSION KIT      | 43300636 | \$130 |
| 9 SECTION LP GAS TO NATURAL GAS CONVERSION KIT      | 43300637 | \$155 |
| MCDONNELL & MILLER WF-2U-24 ELECTRONIC WATER FEEDER | 1630001  | \$465 |
| COMBUSTIBLE FLOOR PLATE FOR ALL CAPACITIES          | 14614032 | \$96  |

PSB SERIES - STANDARD EQUIPMENT

**STANDARD EQUIPMENT:**

- Boiler Control Module: Electronic Low Water Cut-Off with 3/4" Probe, Pressure Limit Control, Steam Pressure Gauge and Glass Water Level Gauge.
- Heat Exchanger: Cast Iron Sections with Cast Iron Push Nipples.
- Combustion: Completely installed and wired gas control system consisting of: Titanium Composite Burners, Gas Manifold with Orifices, Automatic Redundant Combination Gas Valve, 24 Volt, with Pilot Filter and Regulator, Intermittent Pilot Control, Continuous Retry 100% Shut-Off; Combination Pilot Burner/Electrode/Flame Sensor and Integral Draft Diverter.
- Electrical: 24 Volt Transformer.
- Safety: Flame Roll-Out Safety Shut-Off Fuse Link (Roll-Out Switch) and Blocked Vent Safety Shut-Off Manual Reset Disc Thermostat (Spill Switch) with Spare Fuse Link included.
- Other: Assembled Boiler with Insulated Jacket, 3/4" Boiler Drain Valve, 15 psi ASME Pop Safety Valve, (2) 2 1/2" Supply Tappings and (2) 2 1/2" Return Tappings (2) 2 1/2" Square Head Pipe Plugs - to plug unused supply and

**D249 SERIES**

GAS FIRED  
COMMERCIAL STEAM BOILER



**D249 SERIES STEAM  
(STANDARD MODEL)**

| BOILER MODEL | ITEM NUMBER     | TRADE PRICE | INPUT BTU (MBH) | THERM. EFF. | OUT-PUT BTU (MBH) | NET AHRI RATINGS |               |                 | NO. OF SEC. | SHIP WGT. |
|--------------|-----------------|-------------|-----------------|-------------|-------------------|------------------|---------------|-----------------|-------------|-----------|
|              |                 |             |                 |             |                   | STEAM PPF        | STEAM SQ. FT. | STEAM BTU (MBH) |             |           |
| D249300S     | CBA030003101103 | \$7,718     | 300             | 77%         | 233               | 1.33             | 729           | 175             | 4           | 1000      |
| D249400S     | CBA040003101103 | \$8,683     | 400             | 77%         | 310               | 1.33             | 971           | 233             | 5           | 1200      |
| D249500S     | CBA050003101103 | \$9,653     | 500             | 77%         | 388               | 1.33             | 1213          | 291             | 6           | 1400      |
| D249600S     | CBA060003101103 | \$12,553    | 600             | 77%         | 465               | 1.33             | 1454          | 349             | 7           | 1600      |
| D249700S     | CBA070003101103 | \$13,522    | 700             | 77%         | 543               | 1.33             | 1696          | 407             | 8           | 1800      |
| D249800S     | CBA080003101103 | \$14,527    | 800             | 77%         | 620               | 1.33             | 1938          | 465             | 9           | 2000      |
| D249900S     | CBA090003101103 | \$15,590    | 900             | 77%         | 698               | 1.33             | 2183          | 524             | 10          | 2200      |
| D2491000S    | CBA100003101103 | \$16,555    | 1000            | 77%         | 775               | 1.33             | 2421          | 581             | 11          | 2400      |
| D2491100S    | CBA110003101103 | \$19,532    | 1100            | 77%         | 853               | 1.33             | 2667          | 640             | 12          | 2600      |
| D2491200S    | CBA120003101103 | \$20,499    | 1200            | 77%         | 930               | 1.33             | 2908          | 698             | 13          | 2900      |
| D2491300S    | CBA130003101103 | \$22,030    | 1300            | 77%         | 1008              | 1.33             | 3150          | 756             | 14          | 3100      |
| D2491400S    | CBA140003101103 | \$23,001    | 1400            | 77%         | 1085              | 1.33             | 3392          | 814             | 15          | 3300      |
| D2491500S    | CBA150003101103 | \$23,991    | 1500            | 77%         | 1163              | 1.33             | 3633          | 872             | 16          | 3500      |

**(CSD-1 GRAVITY RETURN SYSTEM)**

| BOILER MODEL | ITEM NUMBER     | TRADE PRICE | INPUT BTU (MBH) | THERM. EFF. | OUT-PUT BTU (MBH) | NET AHRI RATINGS |               |                 | NO. OF SEC. | SHIP WGT. |
|--------------|-----------------|-------------|-----------------|-------------|-------------------|------------------|---------------|-----------------|-------------|-----------|
|              |                 |             |                 |             |                   | STEAM PPF        | STEAM SQ. FT. | STEAM BTU (MBH) |             |           |
| D249300S     | CBA030003103103 | \$8,616     | 300             | 77%         | 233               | 1.33             | 729           | 175             | 4           | 1000      |
| D249400S     | CBA040003103103 | \$9,581     | 400             | 77%         | 310               | 1.33             | 971           | 233             | 5           | 1200      |
| D249500S     | CBA050003103103 | \$10,551    | 500             | 77%         | 388               | 1.33             | 1213          | 291             | 6           | 1400      |
| D249600S     | CBA060003103103 | \$14,468    | 600             | 77%         | 465               | 1.33             | 1454          | 349             | 7           | 1600      |
| D249700S     | CBA070003103103 | \$15,455    | 700             | 77%         | 543               | 1.33             | 1696          | 407             | 8           | 1800      |
| D249800S     | CBA080003103103 | \$16,460    | 800             | 77%         | 620               | 1.33             | 1938          | 465             | 9           | 2000      |
| D249900S     | CBA090003103103 | \$17,523    | 900             | 77%         | 698               | 1.33             | 2183          | 524             | 10          | 2200      |
| D2491000S    | CBA100003103103 | \$18,489    | 1000            | 77%         | 775               | 1.33             | 2421          | 581             | 11          | 2400      |
| D2491100S    | CBA110003103103 | \$21,851    | 1100            | 77%         | 853               | 1.33             | 2667          | 640             | 12          | 2600      |
| D2491200S    | CBA120003103103 | \$22,819    | 1200            | 77%         | 930               | 1.33             | 2908          | 698             | 13          | 2900      |
| D2491300S    | CBA130003103103 | \$24,349    | 1300            | 77%         | 1008              | 1.33             | 3150          | 756             | 14          | 3100      |
| D2491400S    | CBA140003103103 | \$25,320    | 1400            | 77%         | 1085              | 1.33             | 3392          | 814             | 15          | 3300      |
| D2491500S    | CBA150003103103 | \$26,310    | 1500            | 77%         | 1163              | 1.33             | 3633          | 872             | 16          | 3500      |



| D249 SERIES STEAM CONTINUED                       |                 |             |                 |             |               |                  |               |                 |             |           |
|---------------------------------------------------|-----------------|-------------|-----------------|-------------|---------------|------------------|---------------|-----------------|-------------|-----------|
| (CSD-1 BOILER FEED PUMP RETURN CONTROL)           |                 |             |                 |             |               |                  |               |                 |             |           |
| BOILER MODEL                                      | ITEM NUMBER     | TRADE PRICE | INPUT BTU (MBH) | THERM. EFF. | OUT-PUT (MBH) | NET AHRI RATINGS |               |                 | NO. OF SEC. | SHIP WGT. |
|                                                   |                 |             |                 |             |               | STEAM PPF        | STEAM SQ. FT. | STEAM BTU (MBH) |             |           |
| D249300S                                          | CBA030003104103 | \$9,538     | 300             | 77%         | 233           | 1.33             | 729           | 175             | 4           | 1000      |
| D249400S                                          | CBA040003104103 | \$10,503    | 400             | 77%         | 310           | 1.33             | 971           | 233             | 5           | 1200      |
| D249500S                                          | CBA050003104103 | \$11,473    | 500             | 77%         | 388           | 1.33             | 1213          | 291             | 6           | 1400      |
| D249600S                                          | CBA060003104103 | \$15,390    | 600             | 77%         | 465           | 1.33             | 1454          | 349             | 7           | 1600      |
| D249700S                                          | CBA070003104103 | \$16,377    | 700             | 77%         | 543           | 1.33             | 1696          | 407             | 8           | 1800      |
| D249800S                                          | CBA080003104103 | \$17,382    | 800             | 77%         | 620           | 1.33             | 1938          | 465             | 9           | 2000      |
| D249900S                                          | CBA090003104103 | \$18,445    | 900             | 77%         | 698           | 1.33             | 2183          | 524             | 10          | 2200      |
| D2491000S                                         | CBA100003104103 | \$19,410    | 1000            | 77%         | 775           | 1.33             | 2421          | 581             | 11          | 2400      |
| D2491100S                                         | CBA110003104103 | \$22,773    | 1100            | 77%         | 853           | 1.33             | 2667          | 640             | 12          | 2600      |
| D2491200S                                         | CBA120003104103 | \$23,740    | 1200            | 77%         | 930           | 1.33             | 2908          | 698             | 13          | 2900      |
| D2491300S                                         | CBA130003104103 | \$25,271    | 1300            | 77%         | 1008          | 1.33             | 3150          | 756             | 14          | 3100      |
| D2491400S                                         | CBA140003104103 | \$26,242    | 1400            | 77%         | 1085          | 1.33             | 3392          | 814             | 15          | 3300      |
| D2491500S                                         | CBA150003104103 | \$27,232    | 1500            | 77%         | 1163          | 1.33             | 3633          | 872             | 16          | 3500      |
| FOR ORDERING KNOCK DOWN OR ALA CARTE              |                 |             |                 |             |               |                  |               |                 |             |           |
| D249-COMPONENTS & OPTIONAL EQUIP.                 |                 |             |                 |             |               |                  |               | PN              | TRADE       |           |
| CAST IRON SECTIONS - RIGHT END (179 LBS.)         |                 |             |                 |             |               |                  |               | 41154050D       | \$868       |           |
| CAST IRON SECTIONS - LEFT END (182 LBS.)          |                 |             |                 |             |               |                  |               | 41154051D       | \$868       |           |
| CAST IRON SECTIONS - INTERMEDIATE (165 LBS.)      |                 |             |                 |             |               |                  |               | 41154052D       | \$757       |           |
| COMPONENT CARTON - 300                            |                 |             |                 |             |               |                  |               | 550002861D      | \$2,308     |           |
| COMPONENT CARTON - 400                            |                 |             |                 |             |               |                  |               | 550002862D      | \$2,444     |           |
| COMPONENT CARTON - 500                            |                 |             |                 |             |               |                  |               | 550002863D      | \$2,565     |           |
| COMPONENT CARTON - 300 CSD-1                      |                 |             |                 |             |               |                  |               | 550002890D      | \$2,694     |           |
| COMPONENT CARTON - 400 CSD-1                      |                 |             |                 |             |               |                  |               | 550002891D      | \$2,830     |           |
| COMPONENT CARTON - 500 CSD-1                      |                 |             |                 |             |               |                  |               | 550002892D      | \$2,951     |           |
| END PANEL CARTON - JACKET                         |                 |             |                 |             |               |                  |               | 550002871D      | \$336       |           |
| END PANEL CARTON - BASE                           |                 |             |                 |             |               |                  |               | 550002860D      | \$303       |           |
| STEAM TRIM - SA 1 (SIZES/MODELS: 300 - 500)       |                 |             |                 |             |               |                  |               | 41200061D       | \$1,126     |           |
| STEAM TRIM - SA 2 (SIZES/MODELS: 600 - 700)       |                 |             |                 |             |               |                  |               | 41200062D       | \$1,143     |           |
| STEAM TRIM - SA 3 (SIZES/MODELS: 800 - 1400)      |                 |             |                 |             |               |                  |               | 41200063D       | \$1,173     |           |
| STEAM TRIM - SA 4 (SIZES/MODELS: 1500)            |                 |             |                 |             |               |                  |               | 41200064D       | \$1,205     |           |
| ACCESSORY CARTON - 300                            |                 |             |                 |             |               |                  |               | 550002877DS     | \$394       |           |
| ACCESSORY CARTON - 400                            |                 |             |                 |             |               |                  |               | 550002878DS     | \$467       |           |
| ACCESSORY CARTON - 500                            |                 |             |                 |             |               |                  |               | 550002867DS     | \$559       |           |
| ACCESSORY CARTON - 600                            |                 |             |                 |             |               |                  |               | 550002879DS     | \$632       |           |
| ACCESSORY CARTON - 700                            |                 |             |                 |             |               |                  |               | 550002880DS     | \$709       |           |
| ACCESSORY CARTON - 800                            |                 |             |                 |             |               |                  |               | 550002881DS     | \$791       |           |
| ACCESSORY CARTON - 900                            |                 |             |                 |             |               |                  |               | 550002882DS     | \$976       |           |
| ACCESSORY CARTON - 1000                           |                 |             |                 |             |               |                  |               | 550002868DS     | \$1,064     |           |
| ACCESSORY CARTON - 1100                           |                 |             |                 |             |               |                  |               | 550002883DS     | \$1,216     |           |
| ACCESSORY CARTON - 1200                           |                 |             |                 |             |               |                  |               | 550002884DS     | \$1,291     |           |
| ACCESSORY CARTON - 1300                           |                 |             |                 |             |               |                  |               | 550002885DS     | \$1,959     |           |
| ACCESSORY CARTON - 1400                           |                 |             |                 |             |               |                  |               | 550002886DS     | \$2,037     |           |
| ACCESSORY CARTON - 1500                           |                 |             |                 |             |               |                  |               | 550002869DS     | \$2,118     |           |
| CSD-1 STEAM TRIM - GRAVITY/CONDENSATE (ALL SIZES) |                 |             |                 |             |               |                  |               | 41257103D       | \$512       |           |
| CSD-1 STEAM TRIM - FEED PUMP (ALL SIZES)          |                 |             |                 |             |               |                  |               | 41257104D       | \$1,434     |           |
| CSD-1 ACCESSORY CARTON - 300                      |                 |             |                 |             |               |                  |               | 550002893DS     | \$394       |           |
| CSD-1 ACCESSORY CARTON - 400                      |                 |             |                 |             |               |                  |               | 550002894DS     | \$467       |           |
| CSD-1 ACCESSORY CARTON - 500                      |                 |             |                 |             |               |                  |               | 550002895DS     | \$559       |           |
| CSD-1 ACCESSORY CARTON - 600                      |                 |             |                 |             |               |                  |               | 550002896DS     | \$1,264     |           |
| CSD-1 ACCESSORY CARTON - 700                      |                 |             |                 |             |               |                  |               | 550002897DS     | \$1,358     |           |
| CSD-1 ACCESSORY CARTON - 800                      |                 |             |                 |             |               |                  |               | 550002898DS     | \$1,440     |           |
| CSD-1 ACCESSORY CARTON - 900                      |                 |             |                 |             |               |                  |               | 550002899DS     | \$1,625     |           |

| D249-COMPONENTS & OPTIONAL EQUIP. CONTINUED | PN          | TRADE   |
|---------------------------------------------|-------------|---------|
| CSD-1 ACCESSORY CARTON - 1000               | 550002900DS | \$1,713 |
| CSD-1 ACCESSORY CARTON - 1100               | 550002901DS | \$1,865 |
| CSD-1 ACCESSORY CARTON - 1200               | 550002902DS | \$1,939 |
| CSD-1 ACCESSORY CARTON - 1300               | 550002903DS | \$2,608 |
| CSD-1 ACCESSORY CARTON - 1400               | 550002904DS | \$2,686 |
| CSD-1 ACCESSORY CARTON - 1500               | 550002905DS | \$2,767 |

| D249 SERIES STEAM CONTINUED                      |           |         |
|--------------------------------------------------|-----------|---------|
| (USE PARTS MULTIPLIER FOR ALL OF THE FOLLOWING)  | PN        | TRADE   |
| STEAM MANUAL RESET PRESSURE CONTROL (L4079B1033) | 14662311  | \$266   |
| M-M 47-2 LWCO & FEEDER (MODELS 300-1500)         | 1280001   | \$1,194 |
| STRAP ON OPERATING CONTROL (L6006C-1034)         | 14662313  | \$160   |
| LWCO, MAN RESET, CSD-1 APPROVED, SHT PROBE       | 240007388 | \$212   |

**D249 SERIES STEAM - STANDARD EQUIPMENT**

**STANDARD EQUIPMENT:**

D249 Series Gas Fired Steam Boilers are low pressure, sectional, cast iron boilers manufactured in 15 heating sizes. Input range from 300,000 to 1,500,000 Btuh for use in larger sized residences, schools, churches, and commercial or industrial buildings. These boilers can be used in multiples to supply even larger loads. The D249 Series Boiler is a modular design. Bases, Jackets and Drafthoods are designed in three modular sizes and all boilers are field assembled using a combination of one or more of these three modules. Boiler bases are preassembled at the factory with the gas valve, manifold, burners, and pilot installed. All drafthoods have a cleanout panel to provide easy access to flueways for inspection and cleaning. On-site boiler assembly is quick and easy with preassembled bases and easy section by section assembly procedures. The same assembly techniques are used on all sizes, so assemblers become familiar with the equipment and are able to reduce installation time and cost. Steam boilers are designed for use with a maximum working pressure of 15 psig. STANDARD EQUIPMENT - STEAM: (67 Low Water Cut-Off, PA404A Pressuretrol and Syphon Loop, Water Gauge Glass Set with Glass and Rods, Steam Gauge, Pop Safety Valve).

**D249 - COMPONENTS & OPTIONAL EQUIPMENT**

**CSD-1 CONTROL REQUIREMENTS**

The optional CSD-1 controls modify the standard D249 boiler on both the fuel train and the steam trim as follows:

**STEAM BOILER WITH BOILER FEED PUMP RETURN SYSTEM**

- Add SF-500 Hydrolevel Safeguard Manual Reset L.W.C.O.
- Add 150S-B-MD L.W.C.O. and Pump Control
- Delete 67D-1 L.W.C.O.
- Add L404L Manual Reset Pressure Control

**STEAM BOILER WITH GRAVITY OR CONDENSATE PUMP RETURN SYSTEM**

- Add SF-500 Hydrolevel Safeguard Manual Reset L.W.C.O.
  - Add L404C Manual Reset Pressure Control
- The SF-500 L.W.C.O. is the secondary L.W.C.O. to the 67D-1 L.W.C.O. furnished standard with the boiler.

**FUEL TRAIN**

Substitute CSD-1 fuel train(s) for standard which includes (per base): Intermittent Pilot Module (PT#1140007) control Stop w/alarm 1003-612A & (PT#1140008) Control CSD1 Lockout Board BD 1145-2 with manual reset; Independent Pilot Gas Line (Manual shut-off valve, Pressure regulator, Safety shut-off valve); Main Gas Line (Gas Valve, Two leak test cocks, Manual shut-off downstream of the main gas valve).

**NOTES:**

1. The D249300S and D249400S do not require fuel train modifications for CSD-1. The standard fuel train is furnished.
2. **Control equipment is included to meet Dunkirk's interpretation of CSD-1. Consult local authorities before the installation of the boiler. Additional controls, if required can be provided at an additional price.**

**EXCELSIOR EXB SERIES**

OIL 3-PASS  
WATER BOILER

65 psi  
MAWP

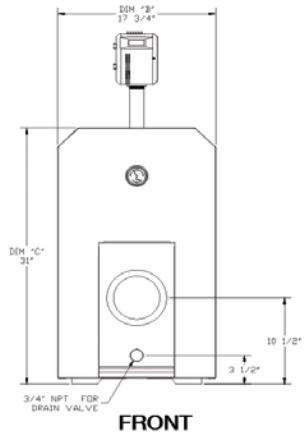

**FRONT**

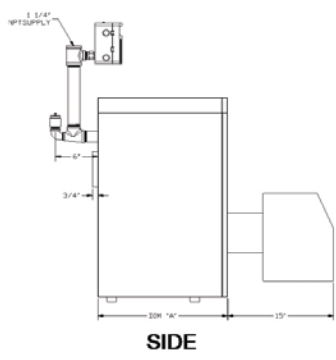

**SIDE**

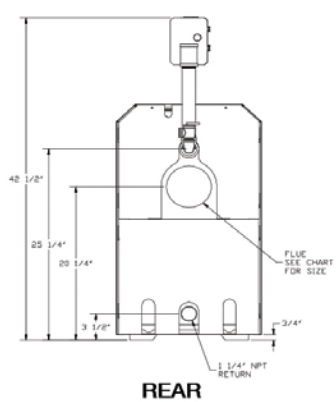

**REAR**



**General Information** (See IOM for complete instructions)

| Clearances                                              |                                                                                 | Combustible Materials (Required) (1)                        | Accessibility, Cleaning & Servicing (2) |
|---------------------------------------------------------|---------------------------------------------------------------------------------|-------------------------------------------------------------|-----------------------------------------|
|                                                         |                                                                                 | (1) Required distances measured from boiler jacket or flue. | <b>Top</b>                              |
| (2) Accessibility, Cleaning & Servicing recommendation. | <b>Right Side</b>                                                               | 2" (5 cm)                                                   | 24" (61 cm)                             |
|                                                         | <b>Left Side</b>                                                                | 2" (5 cm)                                                   | 24" (61 cm)                             |
|                                                         | <b>Floor</b>                                                                    | Combustible                                                 | N/A                                     |
|                                                         | <b>Front</b>                                                                    | 17" (43 cm)                                                 | 24" (61 cm)                             |
| Connections                                             | <b>Back</b>                                                                     | See Flue                                                    | 18" (46 cm)                             |
|                                                         | <b>Flue</b>                                                                     | 9" (23 cm)                                                  | 9" (23 cm)                              |
|                                                         | <b>Return/Supply Water</b>                                                      | 1-1/4" NPT                                                  |                                         |
| <b>All Models</b>                                       | 120 Volts AC, 60 hertz, 1 phase, Less than 12 amps (15 amp circuit recommended) |                                                             |                                         |
| <b>Electrical</b>                                       | 120 Volts AC, 60 hertz, 1 phase, Less than 12 amps (15 amp circuit recommended) |                                                             |                                         |
| <b>Water Content</b>                                    | EXB4 - 3.6 Gallons, EXB5 - 4.3 Gallons, EXB6 - 5.1 Gallons, EXB7 - 5.9 Gallons  |                                                             |                                         |
| <b>Dimensions</b>                                       |                                                                                 |                                                             |                                         |
| <b>Model</b>                                            | <b>A "Depth"</b>                                                                | <b>B "Width"</b>                                            | <b>"C Height"</b>                       |
| EXB4                                                    | 18-3/8 (46 cm)                                                                  | 17-3/4" (45 cm)                                             | 31" (79 cm)                             |
| EXB5                                                    | 21-5/8 (56 cm)                                                                  | 17-3/4" (45 cm)                                             | 31" (79 cm)                             |
| EXB6                                                    | 24-7/8 (64 cm)                                                                  | 17-3/4" (45 cm)                                             | 31" (79 cm)                             |
| EXB7                                                    | 28-1/8 (72 cm)                                                                  | 17-3/4" (45 cm)                                             | 31" (79 cm)                             |

| EXCELSIOR EXB SERIES CONTINUED                                                     |                 |             |             |             |                 |                |               |              |           |           |
|------------------------------------------------------------------------------------|-----------------|-------------|-------------|-------------|-----------------|----------------|---------------|--------------|-----------|-----------|
| (BECKETT BURNER - CHIMNEY VENTED - HYDROLEVEL CONTROL - LESS PUMP)                 |                 |             |             |             |                 |                |               |              |           |           |
| BOILER MODEL                                                                       | ITEM NUMBER     | TRADE PRICE | NO. OF SEC. | INPUT (MBH) | HTG. CAP. (MBH) | AHRI NET (MBH) | AFUE RATING % | CHIMNEY SIZE | FLUE DIA. | SHIP WGT. |
| EXB4075                                                                            | EXB407530200203 | \$2,259     | 4           | 105         | 91              | 79             | 86.0          | 8"x 8"x15'   | 5"        | 436       |
| EXB4095                                                                            | EXB409530200203 | \$2,259     | 4           | 133         | 114             | 99             | 85.0          |              | 5"        | 436       |
| EXB4110                                                                            | EXB411030200203 | \$2,259     | 4           | 154         | 132             | 115            | 84.0          |              | 5"        | 436       |
| EXB5100                                                                            | EXB510030200203 | \$2,575     | 5           | 140         | 122             | 106            | 86.5          |              | 5"        | 496       |
| EXB5115                                                                            | EXB511530200203 | \$2,575     | 5           | 161         | 139             | 121            | 85.0          |              | 5"        | 496       |
| EXB5135                                                                            | EXB513530200203 | \$2,575     | 5           | 189         | 161             | 140            | 84.0          |              | 5"        | 496       |
| EXB6130                                                                            | EXB613030200203 | \$2,717     | 6           | 182         | 159             | 138            | 86.5          |              | 5"        | 560       |
| EXB6145                                                                            | EXB614530200203 | \$2,717     | 6           | 203         | 176             | 153            | 85.0          |              | 5"        | 560       |
| EXB7165                                                                            | EXB716530200203 | \$3,101     | 7           | 231         | 201             | 175            | 86.0          |              | 6"        | 620       |
| (BECKETT BURNER - CHIMNEY VENTED - HYDROLEVEL CONTROL - WITH TACO SYSTEM PUMP)     |                 |             |             |             |                 |                |               |              |           |           |
| BOILER MODEL                                                                       | ITEM NUMBER     | TRADE PRICE | NO. OF SEC. | INPUT (MBH) | HTG. CAP. (MBH) | AHRI NET (MBH) | AFUE RATING % | CHIMNEY SIZE | FLUE DIA. | SHIP WGT. |
| EXB4075                                                                            | EXB407530210203 | \$2,330     | 4           | 105         | 91              | 79             | 86.0          | 8"x 8"x15'   | 5"        | 436       |
| EXB4095                                                                            | EXB409530210203 | \$2,330     | 4           | 133         | 114             | 99             | 85.0          |              | 5"        | 436       |
| EXB4110                                                                            | EXB411030210203 | \$2,330     | 4           | 154         | 132             | 115            | 84.0          |              | 5"        | 436       |
| EXB5100                                                                            | EXB510030210203 | \$2,646     | 5           | 140         | 122             | 106            | 86.5          |              | 5"        | 496       |
| EXB5115                                                                            | EXB511530210203 | \$2,646     | 5           | 161         | 139             | 121            | 85.0          |              | 5"        | 496       |
| EXB5135                                                                            | EXB513530210203 | \$2,646     | 5           | 189         | 161             | 140            | 84.0          |              | 5"        | 496       |
| EXB6130                                                                            | EXB613030210203 | \$2,788     | 6           | 182         | 159             | 138            | 86.5          |              | 5"        | 560       |
| EXB6145                                                                            | EXB614530210203 | \$2,788     | 6           | 203         | 176             | 153            | 85.0          |              | 5"        | 560       |
| EXB7165                                                                            | EXB716530210203 | \$3,172     | 7           | 231         | 201             | 175            | 86.0          |              | 6"        | 620       |
| (BECKETT BURNER - CHIMNEY VENTED - HYDROLEVEL CONTROL - WITH GRUNDFOS SYSTEM PUMP) |                 |             |             |             |                 |                |               |              |           |           |
| BOILER MODEL                                                                       | ITEM NUMBER     | TRADE PRICE | NO. OF SEC. | INPUT (MBH) | HTG. CAP. (MBH) | AHRI NET (MBH) | AFUE RATING % | CHIMNEY SIZE | FLUE DIA. | SHIP WGT. |
| EXB4075                                                                            | EXB407530220203 | \$2,330     | 4           | 105         | 91              | 79             | 86.0          | 8"x 8"x15'   | 5"        | 436       |
| EXB4095                                                                            | EXB409530220203 | \$2,330     | 4           | 133         | 114             | 99             | 85.0          |              | 5"        | 436       |
| EXB4110                                                                            | EXB411030220203 | \$2,330     | 4           | 154         | 132             | 115            | 84.0          |              | 5"        | 436       |
| EXB5100                                                                            | EXB510030220203 | \$2,646     | 5           | 140         | 122             | 106            | 86.5          |              | 5"        | 496       |
| EXB5115                                                                            | EXB511530220203 | \$2,646     | 5           | 161         | 139             | 121            | 85.0          |              | 5"        | 496       |
| EXB5135                                                                            | EXB513530220203 | \$2,646     | 5           | 189         | 161             | 140            | 84.0          |              | 5"        | 496       |
| EXB6130                                                                            | EXB613030220203 | \$2,788     | 6           | 182         | 159             | 138            | 86.5          |              | 5"        | 560       |
| EXB6145                                                                            | EXB614530220203 | \$2,788     | 6           | 203         | 176             | 153            | 85.0          |              | 5"        | 560       |
| EXB7165                                                                            | EXB716530220203 | \$3,172     | 7           | 231         | 201             | 175            | 86.0          |              | 6"        | 620       |
| (LESS BURNER- CHIMNEY VENTED - HYDROLEVEL CONTROL - WITH TACO SYSTEM PUMP)         |                 |             |             |             |                 |                |               |              |           |           |
| BOILER MODEL                                                                       | ITEM NUMBER     | TRADE PRICE | NO. OF SEC. | INPUT (MBH) | HTG. CAP. (MBH) | AHRI NET (MBH) | AFUE RATING % | CHIMNEY SIZE | FLUE DIA. | SHIP WGT. |
| EXB4110                                                                            | EXB411020210203 | \$1,725     | 4           | 154         | 132             | 115            | 84.0          | 8"x 8"x15'   | 5"        | 436       |
| EXB5135                                                                            | EXB513520210203 | \$2,010     | 5           | 189         | 161             | 140            | 84.0          |              | 5"        | 496       |
| EXB6165                                                                            | EXB616520210203 | \$2,208     | 6           | 231         | 198             | 172            | 84.0          |              | 5"        | 560       |
| EXB7190                                                                            | EXB719020210203 | \$2,543     | 7           | 266         | 228             | 198            | 84.0          |              | 6"        | 620       |
| (LESS BURNER- CHIMNEY VENTED - HYDROLEVEL CONTROL - WITH GRUNDFOS SYSTEM PUMP)     |                 |             |             |             |                 |                |               |              |           |           |
| BOILER MODEL                                                                       | ITEM NUMBER     | TRADE PRICE | NO. OF SEC. | INPUT (MBH) | HTG. CAP. (MBH) | AHRI NET (MBH) | AFUE RATING % | CHIMNEY SIZE | FLUE DIA. | SHIP WGT. |
| EXB4110                                                                            | EXB411020220203 | \$1,675     | 4           | 154         | 132             | 115            | 84.0          | 8"x 8"x15'   | 5"        | 436       |
| EXB5135                                                                            | EXB513520220203 | \$1,951     | 5           | 189         | 161             | 140            | 84.0          |              | 5"        | 496       |
| EXB6165                                                                            | EXB616520220203 | \$2,144     | 6           | 231         | 198             | 172            | 84.0          |              | 5"        | 560       |
| EXB7190                                                                            | EXB719020220203 | \$2,469     | 7           | 266         | 228             | 198            | 84.0          |              | 6"        | 620       |

| EXCELSIOR EXB SERIES CONTINUED                                                  |                 |             |             |             |                 |                |               |              |            |           |
|---------------------------------------------------------------------------------|-----------------|-------------|-------------|-------------|-----------------|----------------|---------------|--------------|------------|-----------|
| (LESS BURNER- CHIMENY VENTED - HYDROLEVEL CONTROL - LESS PUMP)                  |                 |             |             |             |                 |                |               |              |            |           |
| BOILER MODEL                                                                    | ITEM NUMBER     | TRADE PRICE | NO. OF SEC. | INPUT (MBH) | HTG. CAP. (MBH) | AHRI NET (MBH) | AFUE RATING % | CHIMNEY SIZE | FLUE DIA.  | SHIP WGT. |
| EXB4110                                                                         | EXB411020200203 | \$1,654     | 4           | 154         | 132             | 115            | 84.0          | 8"x 8"x15'   | 5"         | 436       |
| EXB5135                                                                         | EXB513520200203 | \$1,938     | 5           | 189         | 161             | 140            | 84.0          |              | 5"         | 496       |
| EXB6165                                                                         | EXB616520200203 | \$2,137     | 6           | 231         | 198             | 172            | 84.0          |              | 5"         | 560       |
| EXB7190                                                                         | EXB719020200203 | \$2,472     | 7           | 266         | 228             | 198            | 84.0          |              | 6"         | 620       |
| (BECKETT BURNER - DIRECT VENT - HYDROLEVEL CONTROL - LESS PUMP)                 |                 |             |             |             |                 |                |               |              |            |           |
| BOILER MODEL                                                                    | ITEM NUMBER     | TRADE PRICE | NO. OF SEC. | INPUT (MBH) | HTG. CAP. (MBH) | AHRI NET (MBH) | AFUE RATING % | CHIMNEY SIZE | FLUE DIA.  | SHIP WGT. |
| EXB4075                                                                         | EXB407540200203 | \$2,375     | 4           | 105         | 91              | 79             | 86.0          | 8"x 8"x15'   | 5"         | 436       |
| EXB4095                                                                         | EXB409540200203 | \$2,375     | 4           | 133         | 114             | 99             | 85.0          |              | 5"         | 436       |
| EXB5100                                                                         | EXB510040200203 | \$2,691     | 5           | 140         | 122             | 106            | 86.5          |              | 5"         | 496       |
| EXB5115                                                                         | EXB511540200203 | \$2,691     | 5           | 161         | 139             | 121            | 85.0          |              | 5"         | 496       |
| EXB5135                                                                         | EXB513540200203 | \$2,691     | 5           | 189         | 161             | 140            | 84.0          |              | 5"         | 496       |
| EXB6130                                                                         | EXB613040200203 | \$2,834     | 6           | 182         | 159             | 138            | 86.5          |              | 5"         | 560       |
| (BECKETT BURNER - DIRECT VENT - HYDROLEVEL CONTROL - WITH TACO SYSTEM PUMP)     |                 |             |             |             |                 |                |               |              |            |           |
| BOILER MODEL                                                                    | ITEM NUMBER     | TRADE PRICE | NO. OF SEC. | INPUT (MBH) | HTG. CAP. (MBH) | AHRI NET (MBH) | AFUE RATING % | CHIMNEY SIZE | FLUE DIA.  | SHIP WGT. |
| EXB4075                                                                         | EXB407540210203 | \$2,446     | 4           | 105         | 91              | 79             | 86.0          | 8"x 8"x15'   | 5"         | 436       |
| EXB4095                                                                         | EXB409540210203 | \$2,446     | 4           | 133         | 114             | 99             | 85.0          |              | 5"         | 436       |
| EXB5100                                                                         | EXB510040210203 | \$2,762     | 5           | 140         | 122             | 106            | 86.5          |              | 5"         | 496       |
| EXB5115                                                                         | EXB511540210203 | \$2,762     | 5           | 161         | 139             | 121            | 85.0          |              | 5"         | 496       |
| EXB5135                                                                         | EXB513540210203 | \$2,762     | 5           | 189         | 161             | 140            | 84.0          |              | 5"         | 496       |
| EXB6130                                                                         | EXB613040210203 | \$2,905     | 6           | 182         | 159             | 138            | 86.5          |              | 5"         | 560       |
| (BECKETT BURNER - DIRECT VENT - HYDROLEVEL CONTROL - WITH GRUNDFOS SYSTEM PUMP) |                 |             |             |             |                 |                |               |              |            |           |
| BOILER MODEL                                                                    | ITEM NUMBER     | TRADE PRICE | NO. OF SEC. | INPUT (MBH) | HTG. CAP. (MBH) | AHRI NET (MBH) | AFUE RATING % | CHIMNEY SIZE | FLUE DIA.  | SHIP WGT. |
| EXB4075                                                                         | EXB407540220203 | \$2,446     | 4           | 105         | 91              | 79             | 86.0          | 8"x 8"x15'   | 5"         | 436       |
| EXB4095                                                                         | EXB409540220203 | \$2,446     | 4           | 133         | 114             | 99             | 85.0          |              | 5"         | 436       |
| EXB5100                                                                         | EXB510040220203 | \$2,762     | 5           | 140         | 122             | 106            | 86.5          |              | 5"         | 496       |
| EXB5115                                                                         | EXB511540220203 | \$2,762     | 5           | 161         | 139             | 121            | 85.0          |              | 5"         | 496       |
| EXB5135                                                                         | EXB513540220203 | \$2,762     | 5           | 189         | 161             | 140            | 84.0          |              | 5"         | 496       |
| EXB6130                                                                         | EXB613040220203 | \$2,905     | 6           | 182         | 159             | 138            | 86.5          |              | 5"         | 560       |
| (RIELLO BURNER - CHIMNEY VENTED - LESS PUMP)                                    |                 |             |             |             |                 |                |               |              |            |           |
| BOILER MODEL                                                                    | ITEM NUMBER     | TRADE PRICE | NO. OF SEC. | INPUT (MBH) | HTG. CAP. (MBH) | AHRI NET (MBH) | AFUE RATING % | CHIMNEY SIZE | FLUE DIA.  | SHIP WGT. |
| EXB4075                                                                         | EXB407550200203 | \$2,321     | 4           | 105         | 91              | 79             | 86.0          | 8"x 8"x15'   | 5"         | 436       |
| EXB4095                                                                         | EXB409550200203 | \$2,321     | 4           | 133         | 114             | 99             | 85.0          |              | 5"         | 436       |
| EXB4110                                                                         | EXB411050200203 | \$2,321     | 4           | 154         | 132             | 115            | 84.0          |              | 5"         | 436       |
| EXB5100                                                                         | EXB510050200203 | \$2,679     | 5           | 140         | 122             | 106            | 86.5          |              | 5"         | 496       |
| EXB5115                                                                         | EXB511550200203 | \$2,679     | 5           | 161         | 139             | 121            | 85.0          |              | 5"         | 496       |
| EXB5135                                                                         | EXB513550200203 | \$2,679     | 5           | 189         | 161             | 140            | 84.0          |              | 5"         | 496       |
| EXB6130                                                                         | EXB613050200203 | \$2,819     | 6           | 182         | 159             | 138            | 86.5          |              | 5"         | 560       |
| EXB6145                                                                         | EXB614550200203 | \$2,819     | 6           | 203         | 176             | 153            | 85.0          |              | 5"         | 560       |
| EXB6165                                                                         | EXB616550200203 | \$3,076     | 6           | 231         | 198             | 172            | 84.0          |              | 5"         | 560       |
| EXB7165                                                                         | EXB716550200203 | \$3,153     | 7           | 231         | 201             | 175            | 86.0          |              | 6"         | 620       |
| EXB7180                                                                         | EXB718050200203 | \$3,409     | 7           | 252         | 217             | 189            | 85.0          |              | 6"         | 620       |
| EXB7190                                                                         | EXB719050200203 | \$3,409     | 7           | 266         | 228             | 198            | 84.0          |              | 8"x 8"x20' | 6"        |

| EXCELSIOR EXB SERIES CONTINUED                               |                 |             |             |             |                 |                |               |              |            |           |
|--------------------------------------------------------------|-----------------|-------------|-------------|-------------|-----------------|----------------|---------------|--------------|------------|-----------|
| (RIELLO BURNER - CHIMNEY VENTED - WITH TACO SYSTEM PUMP)     |                 |             |             |             |                 |                |               |              |            |           |
| BOILER MODEL                                                 | ITEM NUMBER     | TRADE PRICE | NO. OF SEC. | INPUT (MBH) | HTG. CAP. (MBH) | AHRI NET (MBH) | AFUE RATING % | CHIMNEY SIZE | FLUE DIA.  | SHIP WGT. |
| EXB4075                                                      | EXB407550210203 | \$2,392     | 4           | 105         | 91              | 79             | 86.0          | 8"x 8"x15'   | 5"         | 436       |
| EXB4095                                                      | EXB409550210203 | \$2,392     | 4           | 133         | 114             | 99             | 85.0          |              | 5"         | 436       |
| EXB4110                                                      | EXB411050210203 | \$2,392     | 4           | 154         | 132             | 115            | 84.0          |              | 5"         | 436       |
| EXB5100                                                      | EXB510050210203 | \$2,750     | 5           | 140         | 122             | 106            | 86.5          |              | 5"         | 496       |
| EXB5115                                                      | EXB511550210203 | \$2,750     | 5           | 161         | 139             | 121            | 85.0          |              | 5"         | 496       |
| EXB5135                                                      | EXB513550210203 | \$2,750     | 5           | 189         | 161             | 140            | 84.0          |              | 5"         | 496       |
| EXB6130                                                      | EXB613050210203 | \$2,890     | 6           | 182         | 159             | 138            | 86.5          |              | 5"         | 560       |
| EXB6145                                                      | EXB614550210203 | \$2,890     | 6           | 203         | 176             | 153            | 85.0          |              | 5"         | 560       |
| EXB6165                                                      | EXB616550210203 | \$3,147     | 6           | 231         | 198             | 172            | 84.0          |              | 5"         | 560       |
| EXB7165                                                      | EXB716550210203 | \$3,224     | 7           | 231         | 201             | 175            | 86.0          |              | 6"         | 620       |
| EXB7180                                                      | EXB718050210203 | \$3,480     | 7           | 252         | 217             | 189            | 85.0          |              | 6"         | 620       |
| EXB7190                                                      | EXB719050210203 | \$3,480     | 7           | 266         | 228             | 198            | 84.0          |              | 8"x 8"x20' | 6"        |
| (RIELLO BURNER - CHIMNEY VENTED - WITH GRUNDFOS SYSTEM PUMP) |                 |             |             |             |                 |                |               |              |            |           |
| BOILER MODEL                                                 | ITEM NUMBER     | TRADE PRICE | NO. OF SEC. | INPUT (MBH) | HTG. CAP. (MBH) | AHRI NET (MBH) | AFUE RATING % | CHIMNEY SIZE | FLUE DIA.  | SHIP WGT. |
| EXB4075                                                      | EXB407550220203 | \$2,392     | 4           | 105         | 91              | 79             | 86.0          | 8"x 8"x15'   | 5"         | 436       |
| EXB4095                                                      | EXB409550220203 | \$2,392     | 4           | 133         | 114             | 99             | 85.0          |              | 5"         | 436       |
| EXB4110                                                      | EXB411050220203 | \$2,392     | 4           | 154         | 132             | 115            | 84.0          |              | 5"         | 436       |
| EXB5100                                                      | EXB510050220203 | \$2,750     | 5           | 140         | 122             | 106            | 86.5          |              | 5"         | 496       |
| EXB5115                                                      | EXB511550220203 | \$2,750     | 5           | 161         | 139             | 121            | 85.0          |              | 5"         | 496       |
| EXB5135                                                      | EXB513550220203 | \$2,750     | 5           | 189         | 161             | 140            | 84.0          |              | 5"         | 496       |
| EXB6130                                                      | EXB613050220203 | \$2,890     | 6           | 182         | 159             | 138            | 86.5          |              | 5"         | 560       |
| EXB6145                                                      | EXB614550220203 | \$2,890     | 6           | 203         | 176             | 153            | 85.0          |              | 5"         | 560       |
| EXB6165                                                      | EXB616550220203 | \$3,147     | 6           | 231         | 198             | 172            | 84.0          |              | 5"         | 560       |
| EXB7165                                                      | EXB716550220203 | \$3,224     | 7           | 231         | 201             | 175            | 86.0          |              | 6"         | 620       |
| EXB7180                                                      | EXB718050220203 | \$3,480     | 7           | 252         | 217             | 189            | 85.0          |              | 6"         | 620       |
| EXB7190                                                      | EXB719050220203 | \$3,480     | 7           | 266         | 228             | 198            | 84.0          |              | 8"x 8"x20' | 6"        |
| (RIELLO 40BF BURNER - DIRECT VENT - LESS PUMP)               |                 |             |             |             |                 |                |               |              |            |           |
| BOILER MODEL                                                 | ITEM NUMBER     | TRADE PRICE | NO. OF SEC. | INPUT (MBH) | HTG. CAP. (MBH) | AHRI NET (MBH) | AFUE RATING % | CHIMNEY SIZE | FLUE DIA.  | SHIP WGT. |
| EXB4075                                                      | EXB407560200203 | \$2,627     | 4           | 105         | 91              | 79             | 86.0          | 8"x 8" x15'  | 5"         | 436       |
| EXB4095                                                      | EXB409560200203 | \$2,627     | 4           | 133         | 114             | 99             | 85.0          |              | 5"         | 436       |
| EXB4110                                                      | EXB411060200203 | \$2,627     | 4           | 154         | 132             | 115            | 84.0          |              | 5"         | 436       |
| EXB5100                                                      | EXB510060200203 | \$2,983     | 5           | 140         | 122             | 106            | 86.5          |              | 5"         | 496       |
| EXB5115                                                      | EXB511560200203 | \$2,983     | 5           | 161         | 139             | 121            | 85.0          |              | 5"         | 496       |
| EXB5135                                                      | EXB513560220203 | \$3,054     | 5           | 189         | 161             | 140            | 84.0          |              | 5"         | 496       |
| EXB6130                                                      | EXB613060200203 | \$3,124     | 6           | 182         | 159             | 138            | 86.5          |              | 5"         | 560       |
| (RIELLO BURNER - DIRECT VENT - WITH TACO SYSTEM PUMP)        |                 |             |             |             |                 |                |               |              |            |           |
| BOILER MODEL                                                 | ITEM NUMBER     | TRADE PRICE | NO. OF SEC. | INPUT (MBH) | HTG. CAP. (MBH) | AHRI NET (MBH) | AFUE RATING % | CHIMNEY SIZE | FLUE DIA.  | SHIP WGT. |
| EXB4075                                                      | EXB407560210203 | \$2,698     | 4           | 105         | 91              | 79             | 86.0          | 8"x 8" x15'  | 5"         | 436       |
| EXB4095                                                      | EXB409560210203 | \$2,698     | 4           | 133         | 114             | 99             | 85.0          |              | 5"         | 436       |
| EXB4110                                                      | EXB411060210203 | \$2,698     | 4           | 154         | 132             | 115            | 84.0          |              | 5"         | 436       |
| EXB5100                                                      | EXB510060210203 | \$3,054     | 5           | 140         | 122             | 106            | 86.5          |              | 5"         | 496       |
| EXB5115                                                      | EXB511560210203 | \$3,054     | 5           | 161         | 139             | 121            | 85.0          |              | 5"         | 496       |
| EXB5135                                                      | EXB513560210203 | \$3,054     | 5           | 189         | 161             | 140            | 84.0          |              | 5"         | 496       |
| EXB6130                                                      | EXB613060210203 | \$3,195     | 6           | 182         | 159             | 138            | 86.5          |              | 5"         | 560       |

| EXCELSIOR EXB SERIES CONTINUED                                                        |                 |             |             |             |                 |                |               |              |           |           |
|---------------------------------------------------------------------------------------|-----------------|-------------|-------------|-------------|-----------------|----------------|---------------|--------------|-----------|-----------|
| (RIELLO 40BF BURNER - DIRECT VENT - WITH GRUNDFOS SYSTEM PUMP)                        |                 |             |             |             |                 |                |               |              |           |           |
| BOILER MODEL                                                                          | ITEM NUMBER     | TRADE PRICE | NO. OF SEC. | INPUT (MBH) | HTG. CAP. (MBH) | AHRI NET (MBH) | AFUE RATING % | CHIMNEY SIZE | FLUE DIA. | SHIP WGT. |
| EXB4075                                                                               | EXB407560220203 | \$2,698     | 4           | 105         | 91              | 79             | 86.0          | 8"x 8" x15'  | 5"        | 436       |
| EXB4095                                                                               | EXB409560220203 | \$2,698     | 4           | 133         | 114             | 99             | 85.0          |              | 5"        | 436       |
| EXB4110                                                                               | EXB411060220203 | \$2,698     | 4           | 154         | 132             | 115            | 84.0          |              | 5"        | 436       |
| EXB5100                                                                               | EXB510060220203 | \$3,054     | 5           | 140         | 122             | 106            | 86.5          |              | 5"        | 496       |
| EXB5115                                                                               | EXB511560220203 | \$3,054     | 5           | 161         | 139             | 121            | 85.0          |              | 5"        | 496       |
| EXB5135                                                                               | EXB513560220203 | \$3,054     | 5           | 189         | 161             | 140            | 84.0          |              | 5"        | 496       |
| EXB6130                                                                               | EXB613060220203 | \$3,195     | 6           | 182         | 159             | 138            | 86.5          |              | 5"        | 560       |
| EXCELSIOR EXB SERIES - VENTING OPTIONS/ADD. EQUIPMENT                                 |                 |             |             |             |                 |                | PN            | TRADE        |           |           |
| 36" RISER TERMINATION                                                                 |                 |             |             |             |                 |                | 29231D        | \$980        |           |           |
| STANDARD TERMINATION                                                                  |                 |             |             |             |                 |                | 28972D        | \$405        |           |           |
| 4" ID X 10 FT DIRECT VENT PIPE KIT (SELECT TERMINATION)                               |                 |             |             |             |                 |                | 240006909D    | \$332        |           |           |
| 4" ID X 15 FT DIRECT VENT PIPE KIT (SELECT TERMINATION)                               |                 |             |             |             |                 |                | 240006910D    | \$438        |           |           |
| 4" ID X 20 FT DIRECT VENT PIPE KIT (SELECT TERMINATION)                               |                 |             |             |             |                 |                | 240006911D    | \$542        |           |           |
| (USE PARTS MULTIPLIER FOR ALL OF THE FOLLOWING)                                       |                 |             |             |             |                 |                | PN            | TRADE        |           |           |
| KIT, HIGH LIMIT MANUAL RESET L4006E1109 WITH PLUG IN HARNESS                          |                 |             |             |             |                 |                | 550001929     | \$212        |           |           |
| FILL-TROL FOR WATER BOILERS 150 MBH OR LESS                                           |                 |             |             |             |                 |                | 14624002      | \$291        |           |           |
| FILL-TROL FOR WATER BOILERS OVER 150 MBH                                              |                 |             |             |             |                 |                | 14624003      | \$392        |           |           |
| REPLACEMENT BURNERS                                                                   |                 |             |             |             |                 |                |               |              |           |           |
| DESCRIPTION                                                                           |                 |             |             |             |                 | MODEL          | PN            | TRADE        |           |           |
| Oil Burner - Beckett Chimney Vent w/o Cover Model AFG except 5115 & 5135 use Model NX |                 |             |             |             |                 | 4075           | 240007232D    | \$565        |           |           |
|                                                                                       |                 |             |             |             |                 | 4095           | 240009385D    | \$565        |           |           |
|                                                                                       |                 |             |             |             |                 | 4110           | 240009386D    | \$565        |           |           |
|                                                                                       |                 |             |             |             |                 | 5100           | 240007233D    | \$598        |           |           |
|                                                                                       |                 |             |             |             |                 | 5115           | 240009387D    | \$598        |           |           |
|                                                                                       |                 |             |             |             |                 | 5135           | 240009388D    | \$598        |           |           |
|                                                                                       |                 |             |             |             |                 | 6130           | 240007234D    | \$540        |           |           |
|                                                                                       |                 |             |             |             |                 | 6145           | 240009389D    | \$540        |           |           |
|                                                                                       |                 |             |             |             |                 | 7165           | 240007235D    | \$591        |           |           |
| Oil Burner - Same as above w/Cover                                                    |                 |             |             |             |                 | 4075           | 240007144D    | \$605        |           |           |
|                                                                                       |                 |             |             |             |                 | 4095           | 240009377D    | \$605        |           |           |
|                                                                                       |                 |             |             |             |                 | 4110           | 240009378D    | \$605        |           |           |
|                                                                                       |                 |             |             |             |                 | 5100           | 240007145D    | \$637        |           |           |
|                                                                                       |                 |             |             |             |                 | 5115           | 240009379D    | \$637        |           |           |
|                                                                                       |                 |             |             |             |                 | 5135           | 240009380D    | \$637        |           |           |
|                                                                                       |                 |             |             |             |                 | 6130           | 240007146D    | \$579        |           |           |
|                                                                                       |                 |             |             |             |                 | 6145           | 240009381D    | \$579        |           |           |
| Oil Burner - Beckett Direct Vent Model NX                                             |                 |             |             |             |                 | 7165           | 240007183D    | \$629        |           |           |
|                                                                                       |                 |             |             |             |                 | 4075           | 240007531D    | \$721        |           |           |
|                                                                                       |                 |             |             |             |                 | 4095           | 240009393D    | \$721        |           |           |
|                                                                                       |                 |             |             |             |                 | 5100           | 240007532D    | \$753        |           |           |
|                                                                                       |                 |             |             |             |                 | 5115           | 240009395D    | \$753        |           |           |
|                                                                                       |                 |             |             |             |                 | 5135           | 240009396D    | \$753        |           |           |
| 6130                                                                                  | 240007533D      | \$696       |             |             |                 |                |               |              |           |           |

| EXCELSIOR EXB SERIES CONTINUED             |       |            |         |
|--------------------------------------------|-------|------------|---------|
| REPLACEMENT BURNERS                        |       |            |         |
| DESCRIPTION                                | MODEL | PN         | TRADE   |
| Oil Burner - Riello Chimney Vent Model 40F | 4075  | 240007502D | \$666   |
|                                            | 4095  | 240009399D | \$666   |
|                                            | 4110  | 240009400D | \$666   |
|                                            | 5100  | 240007503D | \$741   |
|                                            | 5115  | 240009401D | \$741   |
|                                            | 5135  | 550002638D | \$741   |
|                                            | 6130  | 550002639D | \$681   |
|                                            | 6145  | 550002640D | \$681   |
|                                            | 6165  | 240009404D | \$938   |
|                                            | 7165  | 240007505D | \$681   |
|                                            | 7180  | 550002641D | \$938   |
|                                            | 7190  | 240009406D | \$938   |
| Oil Burner - Riello Direct Vent Model 40BF | 4075  | 240007528D | \$973   |
|                                            | 4095  | 240009407D | \$973   |
|                                            | 4110  | 240009408D | \$973   |
|                                            | 5100  | 240007529D | \$1,045 |
|                                            | 5115  | 240009409D | \$1,045 |
|                                            | 5135  | 240009410D | \$1,045 |
|                                            | 6130  | 240007530D | \$987   |
| Oil Burner - Carlin EZ-LF                  | 4075  | 240010357D | \$610   |
|                                            | 4095  |            |         |
|                                            | 4110  |            |         |
|                                            | 5100  |            |         |
|                                            | 5115  |            |         |
|                                            | 5135  |            |         |

**EXB SERIES - STANDARD EQUIPMENT**

**STANDARD EQUIPMENT:**

- Boiler Control Module: Hydrolevel Fuel Smart HydroStat Control - combination Low Water Cut Off with boiler temperature reset and circulator control.
- User Display Interface: Digital display with easy to set dial-type limit settings.
- Heat Exchanger: High efficiency, cast iron, 3-pass design with reversible swing door and target wall. Efficiency baffles/liner by model.
- Combustion: Oil burner with protective cover, flexible oil line.
- Electrical: Wiring harness with Molex connectors. Burner with electrical plug in cord.
- Other: Temperature/pressure gauge, 3/4" ASME relief valve, drain valve, textured painted steel jacket.



**EW II SERIES II**

OIL  
HOT WATER BOILER  
ATMOSPHERIC  
(CHIMNEY VENTED)

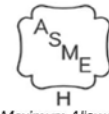

Maximum Allowable Working Pressure 50 psi.

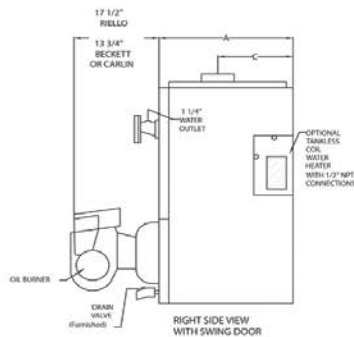
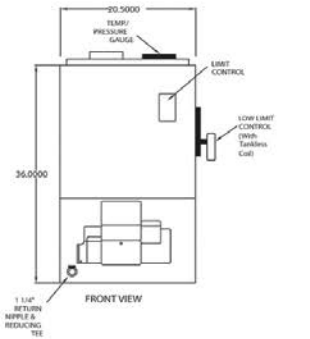

**General Information (See IOM for complete instructions)**

| Clearances                                             |                                                                                 | Combustible Materials Required (1) | Servicing (2)                             | Flue to Combustible Clearance |
|--------------------------------------------------------|---------------------------------------------------------------------------------|------------------------------------|-------------------------------------------|-------------------------------|
| (1)Required distances measured from boiler.            | Top                                                                             | 6" (15.2 cm)                       | 24" (61 cm)                               | 9" (22.9 cm)                  |
|                                                        | Left Side                                                                       | 6" (15.2 cm)                       | N/A                                       |                               |
|                                                        | Right Side                                                                      | 24" (61 cm)                        | N/A                                       |                               |
| (2)Service, proper operation clearance recommendation. | Base                                                                            | Non-Combustible                    | N/A                                       |                               |
|                                                        | Front                                                                           | 24" (61 cm)                        | N/A                                       |                               |
|                                                        | Back                                                                            | 6" (15.2 cm)                       | N/A                                       |                               |
|                                                        | Connections                                                                     | Return/Supply Water                |                                           |                               |
| All Models                                             | 1-1/4" NPT                                                                      |                                    |                                           |                               |
| Electrical                                             | 120 Volts AC, 60 hertz, 1 phase, Less than 12 amps (15 amp circuit recommended) |                                    |                                           |                               |
| Water Content                                          | 3EW - 9.6 Gallons, 4EW - 11.6 Gallons, 5EW - 13.7 Gallons                       |                                    |                                           |                               |
| <b>Dimensions</b>                                      |                                                                                 |                                    |                                           |                               |
| Model                                                  | A "Depth"                                                                       | B "Flue"                           | C "Back of Boiler to Center Line of Flue" |                               |
| 3EW                                                    | 14-1/2"                                                                         | 6"                                 | 8"                                        |                               |
| 4EW                                                    | 17-3/4"                                                                         | 6"                                 | 9-5/8"                                    |                               |
| 5EW                                                    | 21"                                                                             | 6"                                 | 11-1/2"                                   |                               |

| EW II SERIES II LESS COIL CONTINUED          |                 |             |                  |             |                 |                |                   |           |           |
|----------------------------------------------|-----------------|-------------|------------------|-------------|-----------------|----------------|-------------------|-----------|-----------|
| (BECKETT BURNER - LESS PUMP)                 |                 |             |                  |             |                 |                |                   |           |           |
| BOILER MODEL                                 | ITEM NUMBER     | TRADE PRICE | BURNER FIRE RATE | INPUT (MBH) | HTG. CAP. (MBH) | AHRI NET (MBH) | A.F.U.E. RATING % | CHIM DIA. | SHIP WGT. |
| 3EW.65                                       | EWB306531100203 | \$2,659     | 0.65             | 91          | 80              | 70             | 86.3%             | 8"X8"X15' | 470       |
| 3EW.75                                       | EWB307531100203 | \$2,659     | 0.75             | 105         | 92              | 80             | 85.2%             | 8"X8"X15' | 470       |
| 3EW1.00                                      | EWB310031100203 | \$2,659     | 1.00             | 140         | 120             | 104            | 84.0%             | 8"X8"X15' | 470       |
| 4EW.90                                       | EWB409031100203 | \$3,128     | 0.90             | 126         | 111             | 97             | 86.0%             | 8"X8"X15' | 545       |
| 4EW1.25                                      | EWB412531100203 | \$3,128     | 1.25             | 175         | 151             | 131            | 85.0%             | 8"X8"X15' | 545       |
| 4EW1.50                                      | EWB415031100203 | \$3,128     | 1.50             | 210         | 179             | 156            | 84.0%             | 8"X8"X15' | 545       |
| 5EW1.20                                      | EWB512031100203 | \$3,781     | 1.20             | 168         | 147             | 128            | 86.5%             | 8"X8"X15' | 630       |
| 5EW1.75                                      | EWB517531100203 | \$3,781     | 1.75             | 245         | 210             | 183            | 84.3%             | 8"X8"X15' | 630       |
| (BECKETT BURNER - WITH TACO SYSTEM PUMP)     |                 |             |                  |             |                 |                |                   |           |           |
| BOILER MODEL                                 | ITEM NUMBER     | TRADE PRICE | BURNER FIRE RATE | INPUT (MBH) | HTG. CAP. (MBH) | AHRI NET (MBH) | A.F.U.E. RATING % | CHIM DIA. | SHIP WGT. |
| 3EW.65                                       | EWB306531110203 | \$2,731     | 0.65             | 91          | 80              | 70             | 86.3%             | 8"X8"X15' | 470       |
| 3EW.75                                       | EWB307531110203 | \$2,731     | 0.75             | 105         | 92              | 80             | 85.2%             | 8"X8"X15' | 470       |
| 3EW1.00                                      | EWB310031110203 | \$2,731     | 1.00             | 140         | 120             | 104            | 84.0%             | 8"X8"X15' | 470       |
| 4EW.90                                       | EWB409031110203 | \$3,199     | 0.90             | 126         | 111             | 97             | 86.0%             | 8"X8"X15' | 545       |
| 4EW1.25                                      | EWB412531110203 | \$3,199     | 1.25             | 175         | 151             | 131            | 85.0%             | 8"X8"X15' | 545       |
| 4EW1.50                                      | EWB415031110203 | \$3,199     | 1.50             | 210         | 179             | 156            | 84.0%             | 8"X8"X15' | 545       |
| 5EW1.20                                      | EWB512031110203 | \$3,852     | 1.20             | 168         | 147             | 128            | 86.5%             | 8"X8"X15' | 630       |
| 5EW1.75                                      | EWB517531110203 | \$3,852     | 1.75             | 245         | 210             | 183            | 84.3%             | 8"X8"X15' | 630       |
| (BECKETT BURNER - WITH GRUNDFOS SYSTEM PUMP) |                 |             |                  |             |                 |                |                   |           |           |
| BOILER MODEL                                 | ITEM NUMBER     | TRADE PRICE | BURNER FIRE RATE | INPUT (MBH) | HTG. CAP. (MBH) | AHRI NET (MBH) | A.F.U.E. RATING % | CHIM DIA. | SHIP WGT. |
| 3EW.65                                       | EWB306531120203 | \$2,731     | 0.65             | 91          | 80              | 70             | 86.3%             | 8"X8"X15' | 470       |
| 3EW.75                                       | EWB307531120203 | \$2,731     | 0.75             | 105         | 92              | 80             | 85.2%             | 8"X8"X15' | 470       |
| 3EW1.00                                      | EWB310031120203 | \$2,731     | 1.00             | 140         | 120             | 104            | 84.0%             | 8"X8"X15' | 470       |
| 4EW.90                                       | EWB409031120203 | \$3,199     | 0.90             | 126         | 111             | 97             | 86.0%             | 8"X8"X15' | 545       |
| 4EW1.25                                      | EWB412531120203 | \$3,199     | 1.25             | 175         | 151             | 131            | 85.0%             | 8"X8"X15' | 545       |
| 4EW1.50                                      | EWB415031120203 | \$3,199     | 1.50             | 210         | 179             | 156            | 84.0%             | 8"X8"X15' | 545       |
| 5EW1.20                                      | EWB512031120203 | \$3,852     | 1.20             | 168         | 147             | 128            | 86.5%             | 8"X8"X15' | 630       |
| 5EW1.75                                      | EWB517531120203 | \$3,852     | 1.75             | 245         | 210             | 183            | 84.3%             | 8"X8"X15' | 630       |
| (RIELLO F5 BURNER - WITH TACO SYSTEM PUMP)   |                 |             |                  |             |                 |                |                   |           |           |
| BOILER MODEL                                 | ITEM NUMBER     | TRADE PRICE | BURNER FIRE RATE | INPUT (MBH) | HTG. CAP. (MBH) | AHRI NET (MBH) | A.F.U.E. RATING % | CHIM DIA. | SHIP WGT. |
| 3EW.65                                       | EWB306551110203 | \$2,786     | 0.65             | 91          | 80              | 70             | 86.3%             | 8"X8"X15' | 470       |
| 3EW.75                                       | EWB307551110203 | \$2,857     | 0.75             | 105         | 92              | 80             | 85.2%             | 8"X8"X15' | 470       |
| 3EW1.00                                      | EWB310051110203 | \$2,857     | 1.00             | 140         | 120             | 104            | 84.0%             | 8"X8"X15' | 470       |
| 4EW.90                                       | EWB409051110203 | \$3,326     | 0.90             | 126         | 111             | 97             | 86.0%             | 8"X8"X15' | 545       |
| 4EW1.25                                      | EWB412551110203 | \$3,326     | 1.25             | 175         | 151             | 131            | 85.0%             | 8"X8"X15' | 545       |
| 4EW1.50                                      | EWB415051110203 | \$3,326     | 1.50             | 210         | 179             | 156            | 84.0%             | 8"X8"X15' | 545       |

| EW II SERIES II LESS COIL CONTINUED         |                 |             |                  |             |                 |                |                   |           |           |
|---------------------------------------------|-----------------|-------------|------------------|-------------|-----------------|----------------|-------------------|-----------|-----------|
| (RIELLO F10 BURNER - WITH TACO SYSTEM PUMP) |                 |             |                  |             |                 |                |                   |           |           |
| BOILER MODEL                                | ITEM NUMBER     | TRADE PRICE | BURNER FIRE RATE | INPUT (MBH) | HTG. CAP. (MBH) | AHRI NET (MBH) | A.F.U.E. RATING % | CHIM DIA. | SHIP WGT. |
| 5EW1.20                                     | EWB512051110203 | \$3,979     | 1.20             | 168         | 147             | 128            | 86.5%             | 8"X8"X15' | 630       |
| 5EW1.75                                     | EWB517551110203 | \$3,979     | 1.75             | 245         | 210             | 183            | 84.3%             | 8"X8"X15' | 630       |
| (CARLIN EZ1 BURNER - WITH TACO SYSTEM PUMP) |                 |             |                  |             |                 |                |                   |           |           |
| BOILER MODEL                                | ITEM NUMBER     | TRADE PRICE | BURNER FIRE RATE | INPUT (MBH) | HTG. CAP. (MBH) | AHRI NET (MBH) | A.F.U.E. RATING % | CHIM DIA. | SHIP WGT. |
| 3EW.65                                      | EWB306571110203 | \$2,731     | 0.65             | 91          | 80              | 70             | 86.3%             | 8"X8"X15' | 470       |
| 3EW.75                                      | EWB307571110203 | \$2,731     | 0.75             | 105         | 92              | 80             | 85.2%             | 8"X8"X15' | 470       |
| 3EW1.00                                     | EWB310071110203 | \$2,731     | 1.00             | 140         | 120             | 104            | 84.0%             | 8"X8"X15' | 470       |
| 4EW.90                                      | EWB409071110203 | \$3,199     | 0.90             | 126         | 111             | 97             | 86.0%             | 8"X8"X15' | 545       |
| 4EW1.25                                     | EWB412571110203 | \$3,199     | 1.25             | 175         | 151             | 131            | 85.0%             | 8"X8"X15' | 545       |
| 4EW1.50                                     | EWB415071110203 | \$3,199     | 1.50             | 210         | 179             | 156            | 84.0%             | 8"X8"X15' | 545       |
| 5EW1.20                                     | EWB512071110203 | \$3,852     | 1.20             | 168         | 147             | 128            | 86.5%             | 8"X8"X15' | 630       |
| 5EW1.75                                     | EWB517571110203 | \$3,852     | 1.75             | 245         | 210             | 183            | 84.3%             | 8"X8"X15' | 630       |
| (LESS BURNER - WITH TACO SYSTEM PUMP)       |                 |             |                  |             |                 |                |                   |           |           |
| BOILER MODEL                                | ITEM NUMBER     | TRADE PRICE | BURNER FIRE RATE | INPUT (MBH) | HTG. CAP. (MBH) | AHRI NET (MBH) | A.F.U.E. RATING % | CHIM DIA. | SHIP WGT. |
| 3EW.65                                      | EWB310021110203 | \$2,332     | 0.65             | 91          | 80              | 70             | 86.3%             | 8"X8"X15' | 470       |
| 3EW.75                                      |                 |             | 0.75             | 105         | 92              | 80             | 85.2%             | 8"X8"X15' | 470       |
| 3EW1.00                                     |                 |             | 1.00             | 140         | 120             | 104            | 84.0%             | 8"X8"X15' | 470       |
| 4EW.90                                      | EWB415021110203 | \$2,801     | 0.90             | 126         | 111             | 97             | 86.0%             | 8"X8"X15' | 545       |
| 4EW1.25                                     |                 |             | 1.25             | 175         | 151             | 131            | 85.0%             | 8"X8"X15' | 545       |
| 4EW1.50                                     |                 |             | 1.50             | 210         | 179             | 156            | 84.0%             | 8"X8"X15' | 545       |
| 5EW1.20                                     | EWB517521110203 | \$3,172     | 1.20             | 168         | 147             | 128            | 86.5%             | 8"X8"X15' | 630       |
| 5EW1.75                                     |                 |             | 1.75             | 245         | 210             | 183            | 84.3%             | 8"X8"X15' | 630       |
| (LESS BURNER - WITH GRUNDFOS SYSTEM PUMP)   |                 |             |                  |             |                 |                |                   |           |           |
| BOILER MODEL                                | ITEM NUMBER     | TRADE PRICE | BURNER FIRE RATE | INPUT (MBH) | HTG. CAP. (MBH) | AHRI NET (MBH) | A.F.U.E. RATING % | CHIM DIA. | SHIP WGT. |
| 3EW.65                                      | EWB310021120203 | \$2,332     | 0.65             | 91          | 80              | 70             | 86.3%             | 8"X8"X15' | 470       |
| 3EW.75                                      |                 |             | 0.75             | 105         | 92              | 80             | 85.2%             | 8"X8"X15' | 470       |
| 3EW1.00                                     |                 |             | 1.00             | 140         | 120             | 104            | 84.0%             | 8"X8"X15' | 470       |
| 4EW.90                                      | EWB415021120203 | \$2,801     | 0.90             | 126         | 111             | 97             | 86.0%             | 8"X8"X15' | 545       |
| 4EW1.25                                     |                 |             | 1.25             | 175         | 151             | 131            | 85.0%             | 8"X8"X15' | 545       |
| 4EW1.50                                     |                 |             | 1.50             | 210         | 179             | 156            | 84.0%             | 8"X8"X15' | 545       |
| 5EW1.20                                     | EWB517521120203 | \$3,172     | 1.20             | 168         | 147             | 128            | 86.5%             | 8"X8"X15' | 630       |
| 5EW1.75                                     |                 |             | 1.75             | 245         | 210             | 183            | 84.3%             | 8"X8"X15' | 630       |

| EW II SERIES II WITH COIL CONTINUED          |                 |             |                  |             |                 |                |                   |           |                  |           |
|----------------------------------------------|-----------------|-------------|------------------|-------------|-----------------|----------------|-------------------|-----------|------------------|-----------|
| (BECKETT BURNER - LESS PUMP)                 |                 |             |                  |             |                 |                |                   |           |                  |           |
| BOILER MODEL                                 | ITEM NUMBER     | TRADE PRICE | BURNER FIRE RATE | INPUT (MBH) | HTG. CAP. (MBH) | AHRI NET (MBH) | A.F.U.E. RATING % | CHIM DIA. | TANK-LESS G.P.M. | SHIP WGT. |
| 3EW.65                                       | EWB306532100203 | \$3,105     | 0.65             | 91          | 80              | 70             | 86.3%             | 8"X8"X15' | 2.90             | 470       |
| 3EW.75                                       | EWB307532100203 | \$3,105     | 0.75             | 105         | 92              | 80             | 85.2%             | 8"X8"X15' | 3.00             | 470       |
| 3EW1.00                                      | EWB310032100203 | \$3,105     | 1.00             | 140         | 120             | 104            | 84.0%             | 8"X8"X15' | 3.25             | 470       |
| 4EW.90                                       | EWB409032100203 | \$3,577     | 0.90             | 126         | 111             | 97             | 86.0%             | 8"X8"X15' | 3.15             | 545       |
| 4EW1.25                                      | EWB412532100203 | \$3,577     | 1.25             | 175         | 151             | 131            | 85.0%             | 8"X8"X15' | 3.50             | 545       |
| 4EW1.50                                      | EWB415032100203 | \$3,577     | 1.50             | 210         | 179             | 156            | 84.0%             | 8"X8"X15' | 3.75             | 545       |
| 5EW1.20                                      | EWB512032100203 | \$4,236     | 1.20             | 168         | 147             | 128            | 86.5%             | 8"X8"X15' | 3.45             | 630       |
| 5EW1.75                                      | EWB517532100203 | \$4,236     | 1.75             | 245         | 210             | 183            | 84.3%             | 8"X8"X15' | 4.00             | 630       |
| (BECKETT BURNER - WITH TACO SYSTEM PUMP)     |                 |             |                  |             |                 |                |                   |           |                  |           |
| BOILER MODEL                                 | ITEM NUMBER     | TRADE PRICE | BURNER FIRE RATE | INPUT (MBH) | HTG. CAP. (MBH) | AHRI NET (MBH) | A.F.U.E. RATING % | CHIM DIA. | TANK-LESS G.P.M. | SHIP WGT. |
| 3EW.65                                       | EWB306532110203 | \$3,177     | 0.65             | 91          | 80              | 70             | 86.3%             | 8"X8"X15' | 2.90             | 470       |
| 3EW.75                                       | EWB307532110203 | \$3,177     | 0.75             | 105         | 92              | 80             | 85.2%             | 8"X8"X15' | 3.00             | 470       |
| 3EW1.00                                      | EWB310032110203 | \$3,177     | 1.00             | 140         | 120             | 104            | 84.0%             | 8"X8"X15' | 3.25             | 470       |
| 4EW.90                                       | EWB409032110203 | \$3,648     | 0.90             | 126         | 111             | 97             | 86.0%             | 8"X8"X15' | 3.15             | 545       |
| 4EW1.25                                      | EWB412532110203 | \$3,648     | 1.25             | 175         | 151             | 131            | 85.0%             | 8"X8"X15' | 3.50             | 545       |
| 4EW1.50                                      | EWB415032110203 | \$3,648     | 1.50             | 210         | 179             | 156            | 84.0%             | 8"X8"X15' | 3.75             | 545       |
| 5EW1.20                                      | EWB512032110203 | \$4,307     | 1.20             | 168         | 147             | 128            | 86.5%             | 8"X8"X15' | 3.45             | 630       |
| 5EW1.75                                      | EWB517532110203 | \$4,307     | 1.75             | 245         | 210             | 183            | 84.3%             | 8"X8"X15' | 4.00             | 630       |
| (BECKETT BURNER - WITH GRUNDFOS SYSTEM PUMP) |                 |             |                  |             |                 |                |                   |           |                  |           |
| BOILER MODEL                                 | ITEM NUMBER     | TRADE PRICE | BURNER FIRE RATE | INPUT (MBH) | HTG. CAP. (MBH) | AHRI NET (MBH) | A.F.U.E. RATING % | CHIM DIA. | TANK-LESS G.P.M. | SHIP WGT. |
| 3EW.65                                       | EWB306532120203 | \$3,177     | 0.65             | 91          | 80              | 70             | 86.3%             | 8"X8"X15' | 2.90             | 470       |
| 3EW.75                                       | EWB307532120203 | \$3,177     | 0.75             | 105         | 92              | 80             | 85.2%             | 8"X8"X15' | 3.00             | 470       |
| 3EW1.00                                      | EWB310032120203 | \$3,177     | 1.00             | 140         | 120             | 104            | 84.0%             | 8"X8"X15' | 3.25             | 470       |
| 4EW.90                                       | EWB409032120203 | \$3,648     | 0.90             | 126         | 111             | 97             | 86.0%             | 8"X8"X15' | 3.15             | 545       |
| 4EW1.25                                      | EWB412532120203 | \$3,648     | 1.25             | 175         | 151             | 131            | 85.0%             | 8"X8"X15' | 3.50             | 545       |
| 4EW1.50                                      | EWB415032120203 | \$3,648     | 1.50             | 210         | 179             | 156            | 84.0%             | 8"X8"X15' | 3.75             | 545       |
| 5EW1.20                                      | EWB512032120203 | \$4,307     | 1.20             | 168         | 147             | 128            | 86.5%             | 8"X8"X15' | 3.45             | 630       |
| 5EW1.75                                      | EWB517532120203 | \$4,307     | 1.75             | 245         | 210             | 183            | 84.3%             | 8"X8"X15' | 4.00             | 630       |
| (RIELLO F5 BURNER - WITH TACO SYSTEM PUMP)   |                 |             |                  |             |                 |                |                   |           |                  |           |
| BOILER MODEL                                 | ITEM NUMBER     | TRADE PRICE | BURNER FIRE RATE | INPUT (MBH) | HTG. CAP. (MBH) | AHRI NET (MBH) | A.F.U.E. RATING % | CHIM DIA. | TANK-LESS G.P.M. | SHIP WGT. |
| 3EW.65                                       | EWB306552110203 | \$3,302     | 0.65             | 91          | 80              | 70             | 86.3%             | 8"X8"X15' | 2.90             | 470       |
| 3EW.75                                       | EWB307552110203 | \$3,302     | 0.75             | 105         | 92              | 80             | 85.2%             | 8"X8"X15' | 3.00             | 470       |
| 3EW1.00                                      | EWB310052110203 | \$3,302     | 1.00             | 140         | 120             | 104            | 84.0%             | 8"X8"X15' | 3.25             | 470       |
| 4EW.90                                       | EWB409052110203 | \$3,775     | 0.90             | 126         | 111             | 97             | 86.0%             | 8"X8"X15' | 3.15             | 545       |
| 4EW1.25                                      | EWB412552110203 | \$3,775     | 1.25             | 175         | 151             | 131            | 85.0%             | 8"X8"X15' | 3.50             | 545       |
| 4EW1.50                                      | EWB415052110203 | \$3,775     | 1.50             | 210         | 179             | 156            | 84.0%             | 8"X8"X15' | 3.75             | 545       |

| EW II SERIES II WITH COIL CONTINUED         |                 |             |                  |             |                 |                |                   |           |                  |           |
|---------------------------------------------|-----------------|-------------|------------------|-------------|-----------------|----------------|-------------------|-----------|------------------|-----------|
| (RIELLO F10 BURNER - WITH TACO SYSTEM PUMP) |                 |             |                  |             |                 |                |                   |           |                  |           |
| BOILER MODEL                                | ITEM NUMBER     | TRADE PRICE | BURNER FIRE RATE | INPUT (MBH) | HTG. CAP. (MBH) | AHRI NET (MBH) | A.F.U.E. RATING % | CHIM DIA. | TANK-LESS G.P.M. | SHIP WGT. |
| 5EW1.20                                     | EWB512052110203 | \$4,746     | 1.20             | 168         | 147             | 128            | 86.5%             | 8"X8"X15' | 3.45             | 630       |
| 5EW1.75                                     | EWB517552110203 | \$4,746     | 1.75             | 245         | 210             | 183            | 84.3%             | 8"X8"X15' | 4.00             | 630       |
| (CARLIN EZ1 BURNER - WITH TACO SYSTEM PUMP) |                 |             |                  |             |                 |                |                   |           |                  |           |
| BOILER MODEL                                | ITEM NUMBER     | TRADE PRICE | BURNER FIRE RATE | INPUT (MBH) | HTG. CAP. (MBH) | AHRI NET (MBH) | A.F.U.E. RATING % | CHIM DIA. | TANK-LESS G.P.M. | SHIP WGT. |
| 3EW.65                                      | EWB306572110203 | \$3,177     | 0.65             | 91          | 80              | 70             | 86.3%             | 8"X8"X15' | 2.90             | 470       |
| 3EW.75                                      | EWB307572110203 | \$3,177     | 0.75             | 105         | 92              | 80             | 85.2%             | 8"X8"X15' | 3.00             | 470       |
| 3EW1.00                                     | EWB310072110203 | \$3,177     | 1.00             | 140         | 120             | 104            | 84.0%             | 8"X8"X15' | 3.25             | 470       |
| 4EW.90                                      | EWB409072110203 | \$3,648     | 0.90             | 126         | 111             | 97             | 86.0%             | 8"X8"X15' | 3.15             | 545       |
| 4EW1.25                                     | EWB412572110203 | \$3,648     | 1.25             | 175         | 151             | 131            | 85.0%             | 8"X8"X15' | 3.50             | 545       |
| 4EW1.50                                     | EWB415072110203 | \$3,648     | 1.50             | 210         | 179             | 156            | 84.0%             | 8"X8"X15' | 3.75             | 545       |
| 5EW1.20                                     | EWB512072110203 | \$4,307     | 1.20             | 168         | 147             | 128            | 86.5%             | 8"X8"X15' | 3.45             | 630       |
| 5EW1.75                                     | EWB517572110203 | \$4,307     | 1.75             | 245         | 210             | 183            | 84.3%             | 8"X8"X15' | 4.00             | 630       |
| (LESS BURNER - WITH TACO SYSTEM PUMP)       |                 |             |                  |             |                 |                |                   |           |                  |           |
| BOILER MODEL                                | ITEM NUMBER     | TRADE PRICE | BURNER FIRE RATE | INPUT (MBH) | HTG. CAP. (MBH) | AHRI NET (MBH) | A.F.U.E. RATING % | CHIM DIA. | TANK-LESS G.P.M. | SHIP WGT. |
| 3EW.65                                      | EWB310022110203 | \$2,779     | 0.65             | 91          | 80              | 70             | 86.3%             | 8"X8"X15' | 2.90             | 470       |
| 3EW.75                                      |                 |             | 0.75             | 105         | 92              | 80             | 85.2%             | 8"X8"X15' | 3.00             | 470       |
| 3EW1.00                                     |                 |             | 1.00             | 140         | 120             | 104            | 84.0%             | 8"X8"X15' | 3.25             | 470       |
| 4EW.90                                      | EWB415022110203 | \$3,251     | 0.90             | 126         | 111             | 97             | 86.0%             | 8"X8"X15' | 3.15             | 545       |
| 4EW1.25                                     |                 |             | 1.25             | 175         | 151             | 131            | 85.0%             | 8"X8"X15' | 3.50             | 545       |
| 4EW1.50                                     |                 |             | 1.50             | 210         | 179             | 156            | 84.0%             | 8"X8"X15' | 3.75             | 545       |
| 5EW1.20                                     | EWB517522110203 | \$3,670     | 1.20             | 168         | 147             | 128            | 86.5%             | 8"X8"X15' | 3.45             | 630       |
| 5EW1.75                                     |                 |             | 1.75             | 245         | 210             | 183            | 84.3%             | 8"X8"X15' | 4.00             | 630       |
| (LESS BURNER - WITH GRUNDFOS SYSTEM PUMP)   |                 |             |                  |             |                 |                |                   |           |                  |           |
| BOILER MODEL                                | ITEM NUMBER     | TRADE PRICE | BURNER FIRE RATE | INPUT (MBH) | HTG. CAP. (MBH) | AHRI NET (MBH) | A.F.U.E. RATING % | CHIM DIA. | TANK-LESS G.P.M. | SHIP WGT. |
| 3EW.65                                      | EWB310022120203 | \$2,779     | 0.65             | 91          | 80              | 70             | 86.3%             | 8"X8"X15' | 2.90             | 470       |
| 3EW.75                                      |                 |             | 0.75             | 105         | 92              | 80             | 85.2%             | 8"X8"X15' | 3.00             | 470       |
| 3EW1.00                                     |                 |             | 1.00             | 140         | 120             | 104            | 84.0%             | 8"X8"X15' | 3.25             | 470       |
| 4EW.90                                      | EWB415022120203 | \$3,251     | 0.90             | 126         | 111             | 97             | 86.0%             | 8"X8"X15' | 3.15             | 545       |
| 4EW1.25                                     |                 |             | 1.25             | 175         | 151             | 131            | 85.0%             | 8"X8"X15' | 3.50             | 545       |
| 4EW1.50                                     |                 |             | 1.50             | 210         | 179             | 156            | 84.0%             | 8"X8"X15' | 3.75             | 545       |
| 5EW1.20                                     | EWB517522120203 | \$3,670     | 1.20             | 168         | 147             | 128            | 86.5%             | 8"X8"X15' | 3.45             | 630       |
| 5EW1.75                                     |                 |             | 1.75             | 245         | 210             | 183            | 84.3%             | 8"X8"X15' | 4.00             | 630       |

| <b>EW II SERIES II CONTINUED</b>                                                                            |           |              |
|-------------------------------------------------------------------------------------------------------------|-----------|--------------|
|                                                                                                             | <b>PN</b> | <b>TRADE</b> |
| <b>*RIELLO BURNER (3 &amp; 4 SECTION)</b>                                                                   | 43300005  | \$612        |
| <b>*RIELLO BURNER (5 SECTION)</b>                                                                           | 43300010  | \$1,056      |
| <b>*CARLIN EZ-1 BURNER (3 &amp; 4 SECTION)</b>                                                              | 43300003  | \$461        |
| <b>*CARLIN EZ-2 BURNER (5 SECTION)</b>                                                                      | 43300004  | \$558        |
| <b>*NOTE: PURCHASE OF BURNER IN BOX REQUIRES ADDITIONAL PURCHASE OF CORRECT RERATE KIT FROM LIST BELOW.</b> |           |              |
| <b>(USE PARTS MULTIPLIER FOR ALL OF THE FOLLOWING)</b>                                                      |           |              |
|                                                                                                             | <b>PN</b> | <b>TRADE</b> |
| <b>3 SECTION BECKETT BURNER RE-RATE KIT, 1.00 GPH</b>                                                       | 550002666 | \$67         |
| <b>3 SECTION BECKETT BURNER RE-RATE KIT, 0.75 GPH</b>                                                       | 550002676 | \$67         |
| <b>3 SECTION BECKETT BURNER RE-RATE KIT, 0.65 GPH</b>                                                       | 550002677 | \$67         |
| <b>4 SECTION BECKETT BURNER RE-RATE KIT, 1.50 GPH</b>                                                       | 550002667 | \$67         |
| <b>4 SECTION BECKETT BURNER RE-RATE KIT, 1.25 GPH</b>                                                       | 550002675 | \$67         |
| <b>4 SECTION BECKETT BURNER RE-RATE KIT, 0.90 GPH</b>                                                       | 550002678 | \$67         |
| <b>5 SECTION BECKETT BURNER RE-RATE KIT, 1.20/1.75 GPH</b>                                                  | 550002668 | \$67         |
| <b>3 SECTION RIELLO BURNER RE-RATE KIT, 0.65/0.75/1.00 GPH</b>                                              | 550002669 | \$66         |
| <b>4 SECTION RIELLO BURNER RE-RATE KIT, .090/1.25/1.50 GPH</b>                                              | 550002670 | \$66         |
| <b>5 SECTION RIELLO BURNER RE-RATE KIT, 1.75 GPH</b>                                                        | 550002671 | \$56         |
| <b>3 SECTION CARLIN BURNER RE-RATE KIT, 0.65/0.75/1.00 GPH</b>                                              | 550002672 | \$62         |
| <b>4 SECTION CARLIN BURNER RE-RATE KIT, 0.90/1.25/1.50 GPH</b>                                              | 550002673 | \$62         |
| <b>5 SECTION CARLIN BURNER RE-RATE KIT, 1.75 GPH</b>                                                        | 550002674 | \$54         |
| <b>FILL-TROL #110 FOR WATER BOILERS 150 MBH OR LESS</b>                                                     | 14624002  | \$291        |
| <b>FILL-TROL #111 FOR WATER BOILERS OVER 150 MBH</b>                                                        | 14624003  | \$392        |

**EW II SERIES II - STANDARD EQUIPMENT**

**STANDARD EQUIPMENT:**

- Boiler Control Module: Boilers without Tankless Heater Coil - Honeywell Combination High Limit Control and Circulator Relay. Boilers with Tankless Heater Coil - Honeywell Combination High Limit and Circulator Relay and Low Limit Control.
- Heat Exchanger: Cast Iron Sections with Cast Iron Push Nipples and Swing Door.
- Combustion: Completely installed and wired Beckett AFG Series Oil Burner (3 & 4 Section F Head; 5 Section MD Head) equipped with Nozzle, Primary Control, CAD Cell, PSC Motor, Interrupted Duty Ignition and Clean Cut Pump; Flue Brush; Swing Fire Door with Insulation (Vacuum Formed Ceramic Fiber), Target Wall (Vacuum Formed Refractory Ceramic Fiber); Dura Blanket Insulation Chamber. Chamber, and Barometric Draft Control 6".
- Other: Assembled Cast Iron Boiler with Insulated Jacket, Combination Temperature/Pressure Gauge, Circulator Pump wired with 5' harness for supply or return mounting in the field, 3/4" Boiler Drain Valve, 30 psi ASME Relief Valve, extra Boiler Tap for Expansion Tank or Air Elimination.

**ESC IV SERIES**

**OIL  
STEAM BOILER**



H  
Tested for 15 psi ASME  
Working Pressure



**Front View**

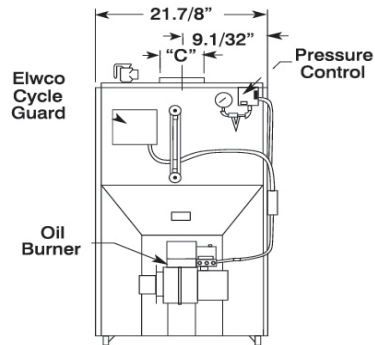

**General Information** (See IOM for complete instructions)

|                    |                                                                                                                                                |              |
|--------------------|------------------------------------------------------------------------------------------------------------------------------------------------|--------------|
| <b>Clearances</b>  | <b>Combustible Materials (Required) (1)</b>                                                                                                    |              |
|                    | <b>Top</b>                                                                                                                                     | 24" (610 mm) |
|                    | <b>Left Side (Control Side)</b>                                                                                                                | 6" (152 mm)  |
|                    | <b>Right Side</b>                                                                                                                              | 24" (610 mm) |
|                    | <b>Front</b>                                                                                                                                   | 24" (610 mm) |
|                    | <b>Back</b>                                                                                                                                    | 24" (610 mm) |
|                    | <b>Flue Connector</b>                                                                                                                          | 9" (229 mm)  |
| <b>Connections</b> | Supply Tapping Two 2" NPT, Return Tapping 1-1/2", Oil Line 3/8" O.D. copper tubing for runs of 50 feet or less, and 1/2" O.D. for longer runs. |              |
| <b>Electrical</b>  | 120 Volts AC, 60 hertz, 1 phase, Less than 12 amps (15 amp circuit recommended)                                                                |              |

**Side View**

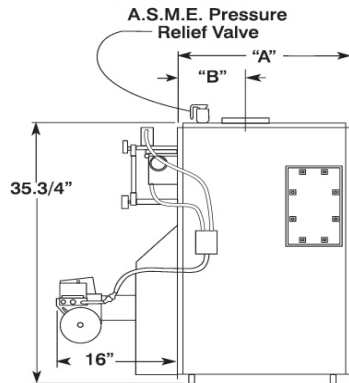

**Tankless Heater Capacities** (Note: ST=With Tankless Coil, S=No Coil)

| Model      | Input Rate G.P.H. | Tank-less Heater Number | Tankless Heater Capacity Intermittent Draw G.P.M. | Boiler Water Content (Gallons) |              |
|------------|-------------------|-------------------------|---------------------------------------------------|--------------------------------|--------------|
|            |                   |                         |                                                   | To Water Line                  | To LWCO Line |
| ESC-3090ST | 0.90              | L-24                    | Avail. On Req.                                    | 11                             | 8            |
| ESC-4125ST | 1.25              |                         | 4.5                                               | 13                             | 9            |
| ESC-5185ST | 1.85              |                         | 4.5                                               | 15                             | 10           |
| ESC-6210ST | 2.10              |                         | 4.5                                               | 15                             | 10           |

**Dimensions**

| No. of Sec. | A (Length of Flush Jacket) | B (Front of Jacket to Center Line of Flue Outlet) | C (Flue Outlet Diameter) |
|-------------|----------------------------|---------------------------------------------------|--------------------------|
| 3           | 16.375"                    | 6.5"                                              | 6"                       |
| 4           | 20.25"                     | 8.5"                                              | 6"                       |
| 5           | 23.875"                    | 10.25"                                            | 7"                       |
| 6           | 27.5"                      | 8.3125"                                           | 8"                       |

| ESC IV SERIES CONTINUED                                                                                                                                                                                                                                                                                                                                                                                                                                                                                                                                                                                                                                                                                                                                                                      |                 |             |             |             |                 |                |                        |               |               |           |
|----------------------------------------------------------------------------------------------------------------------------------------------------------------------------------------------------------------------------------------------------------------------------------------------------------------------------------------------------------------------------------------------------------------------------------------------------------------------------------------------------------------------------------------------------------------------------------------------------------------------------------------------------------------------------------------------------------------------------------------------------------------------------------------------|-----------------|-------------|-------------|-------------|-----------------|----------------|------------------------|---------------|---------------|-----------|
| (BECKETT BURNER - WITH TANKLESS COVER PLATE)                                                                                                                                                                                                                                                                                                                                                                                                                                                                                                                                                                                                                                                                                                                                                 |                 |             |             |             |                 |                |                        |               |               |           |
| BOILER MODEL                                                                                                                                                                                                                                                                                                                                                                                                                                                                                                                                                                                                                                                                                                                                                                                 | ITEM NUMBER     | TRADE PRICE | No. of Sec. | INPUT (MBH) | HTG. CAP. (MBH) | AHRI NET (MBH) | AHRI NET SQ. FT. STEAM | Fir. Rate GPH | AFUE RATING % | SHIP WGT. |
| ESC-3090S                                                                                                                                                                                                                                                                                                                                                                                                                                                                                                                                                                                                                                                                                                                                                                                    | ESC309031100403 | \$3,155     | 3           | 126         | 106             | 80             | 333                    | 0.90          | 82.0%         | 534       |
| ESC-4125S                                                                                                                                                                                                                                                                                                                                                                                                                                                                                                                                                                                                                                                                                                                                                                                    | ESC412531100403 | \$3,641     | 4           | 175         | 147             | 110            | 458                    | 1.25          | 82.0%         | 688       |
| ESC-5185S                                                                                                                                                                                                                                                                                                                                                                                                                                                                                                                                                                                                                                                                                                                                                                                    | ESC518531100403 | \$3,949     | 5           | 259         | 216             | 162            | 675                    | 1.85          | 82.0%         | 781       |
| ESC-6210S                                                                                                                                                                                                                                                                                                                                                                                                                                                                                                                                                                                                                                                                                                                                                                                    | ESC621031100403 | \$4,316     | 6           | 294         | 247             | 185            | 771                    | 2.10          | 82.0%         | 901       |
| (BECKETT BURNER - WITH TANKLESS COIL)                                                                                                                                                                                                                                                                                                                                                                                                                                                                                                                                                                                                                                                                                                                                                        |                 |             |             |             |                 |                |                        |               |               |           |
| BOILER MODEL                                                                                                                                                                                                                                                                                                                                                                                                                                                                                                                                                                                                                                                                                                                                                                                 | ITEM NUMBER     | TRADE PRICE | No. of Sec. | INPUT (MBH) | HTG. CAP. (MBH) | AHRI NET (MBH) | AHRI NET SQ. FT. STEAM | Fir. Rate GPH | AFUE RATING % | SHIP WGT. |
| ESC-3090ST                                                                                                                                                                                                                                                                                                                                                                                                                                                                                                                                                                                                                                                                                                                                                                                   | ESC309032100403 | \$3,534     | 3           | 126         | 106             | 80             | 333                    | 0.90          | 82.0%         | 534       |
| ESC-4125ST                                                                                                                                                                                                                                                                                                                                                                                                                                                                                                                                                                                                                                                                                                                                                                                   | ESC412532100403 | \$4,020     | 4           | 175         | 147             | 110            | 458                    | 1.25          | 82.0%         | 688       |
| ESC-5185ST                                                                                                                                                                                                                                                                                                                                                                                                                                                                                                                                                                                                                                                                                                                                                                                   | ESC518532100403 | \$4,327     | 5           | 259         | 216             | 162            | 675                    | 1.85          | 82.0%         | 781       |
| ESC-6210ST                                                                                                                                                                                                                                                                                                                                                                                                                                                                                                                                                                                                                                                                                                                                                                                   | ESC621032100403 | \$4,695     | 6           | 294         | 247             | 185            | 771                    | 2.10          | 82.0%         | 901       |
| ESC IV SERIES - STANDARD EQUIPMENT                                                                                                                                                                                                                                                                                                                                                                                                                                                                                                                                                                                                                                                                                                                                                           |                 |             |             |             |                 |                |                        |               |               |           |
| <p><b><u>STANDARD EQUIPMENT:</u></b><br/>                     Boiler Controls: Honeywell Pressuretrol, Boiler Water Level Gauge Glass, and Steam Pressure Gauge.<br/>                     Heat Exchanger: Cast Iron Heat Exchanger with Cast Iron Push Nipples, Swing Door.<br/>                     Combustion: Beckett Oil Burner, Target Wall/Liner.<br/>                     Electrical: Wiring Harness, Burner Electric Disconnect.<br/>                     Safety: Electronic Low Water Cut Off.<br/>                     Other: Crated Boiler, Flush Jacket, ASME Relief Valve, Drain Valve, Plastic Cover, Two 2" Supply Tappings, 1-1/2" Return Tapping and Skim Port.<br/>                     For Tankless Heater Units: Add Tankless Hot Water Coil and 4006 Limit Control.</p> |                 |             |             |             |                 |                |                        |               |               |           |



**H2O SERIES**  
**STAINLESS STEEL**  
**SINGLE COIL**  
**INDIRECT WATER HEATER**

**H2O I 30 L DK**

I=Indirect

Capacity:  
 30=30 Gals.  
 40=40 Gals.  
 50=50 Gals.  
 60=60 Gals.  
 80=80 Gals.  
 85=87 Gals.  
 115=115 Gals.

L=Lowboy  
 C=Commercial  
 HO=High Output  
 HOC=High Output  
 Commercial  
 XHO=Extra High  
 Output

DK=Dunkirk



Conforms to UL STD 174  
 Certified to CAN/CSA STD C22.2 No. 110-94

**STANDARD AND HO UNITS**

**HOC UNITS**

**XHOC EXTRA HIGH OUTPUT UNITS**

Note: Max. Working pressure 150 psi for all capacities.

**General Information (See IOM for complete instructions)**

| Model          | Piping Connections NPT         |                              | Height (Inches) | Dia. (Inches) |
|----------------|--------------------------------|------------------------------|-----------------|---------------|
|                | Domestic Water In/Out (Inches) | Boiler Water In/Out (Inches) |                 |               |
| H2OI30DK       | 3/4                            | 1                            | 34.0            | 23.5          |
| H2OI40DK       | 3/4                            | 1                            | 44.0            | 23.5          |
| H2OI40LDK      | 3/4                            | 1                            | 36.0            | 28.0          |
| H2OI50DK       | 3/4                            | 1                            | 54.0            | 23.5          |
| H2OI60DK       | 3/4                            | 1                            | 62.0            | 23.5          |
| H2OI60LDK      | 3/4                            | 1                            | 46.0            | 28.0          |
| H2OI80DK       | 1                              | 1                            | 56.0            | 28.0          |
| H2OI115DK      | 1                              | 1                            | 74.0            | 28.0          |
| H2OI60HODK     | 1                              | 1                            | 62.0            | 23.5          |
| H2OI80HODK     | 1                              | 1                            | 56.0            | 28.0          |
| H2OI80HOC DK   | 1-1/2                          | 1-1/4                        | 56.0            | 28.0          |
| H2OI115HODK    | 1                              | 1                            | 74.0            | 28.0          |
| H2OI115HOC DK  | 1-1/2                          | 1-1/4                        | 74.0            | 28.0          |
| H2OI85XHOC DK  | 1-1/2                          | 1-1/2                        | 64.0            | 28.0          |
| H2OI115XHOC DK | 1-1/2                          | 1-1/2                        | 74.0            | 28.0          |

**H2O SINGLE COIL STAINLESS STEEL INDIRECT WATER HEATERS CONTINUED**

| MODEL          | TRADE PRICE | STOR. CAP. (Gals.) | DESCRIPTION            | MAX. FIRST HOUR RATING Gal./Hr. @ |       | BOILER OUTPUT REQ. (BTU/Hr.) | SHP. WGT. (LBS.) |
|----------------|-------------|--------------------|------------------------|-----------------------------------|-------|------------------------------|------------------|
|                |             |                    |                        | 140°F                             | 115°F |                              |                  |
| H2OI30DK       | \$1,305     | 30                 | STANDARD               | 202                               | 269   | 131,250                      | 85               |
| H2OI40DK       | \$1,342     | 40                 | STANDARD               | 221                               | 292   | 138,670                      | 100              |
| H2OI40LDK      | \$1,430     | 42                 | LOWBOY                 | 212                               | 251   | 132,000                      | 100              |
| H2OI50DK       | \$1,620     | 50                 | STANDARD               | 223                               | 291   | 133,280                      | 110              |
| H2OI60DK       | \$1,938     | 60                 | STANDARD               | 262                               | 342   | 155,700                      | 125              |
| H2OI60LDK      | \$1,993     | 60                 | LOWBOY                 | 239                               | 310   | 138,570                      | 120              |
| H2OI80DK       | \$2,148     | 80                 | STANDARD               | 271                               | 248   | 149,390                      | 140              |
| H2OI115DK      | \$3,188     | 115                | STANDARD               | 324                               | 409   | 165,750                      | 175              |
| H2OI60HODK     | \$2,090     | 60                 | HIGH OUTPUT            | 406                               | 541   | 263,600                      | 145              |
| H2OI80HODK     | \$2,905     | 80                 | HIGH OUTPUT            | 418                               | 551   | 259,640                      | 155              |
| H2OI80HOC DK   | \$3,136     | 80                 | HIGH OUTPUT COMMERCIAL | 442                               | 584   | 227,070                      | 155              |
| H2OI115HODK    | \$3,929     | 115                | HIGH OUTPUT            | 467                               | 607   | 273,100                      | 190              |
| H2OI115HOC DK  | \$4,159     | 115                | HIGH OUTPUT COMMERCIAL | 479                               | 623   | 281,300                      | 190              |
| H2OI85XHOC DK  | \$3,904     | 87                 | EXTRA HIGH OUTPUT      | 738                               | 992   | 495,000                      | 215              |
| H2OI115XHOC DK | \$4,634     | 115                | EXTRA HIGH OUTPUT      | 763                               | 1017  | 495,000                      | 240              |

**H2O SINGLE COIL INDIRECT WATER HEATERS WITH ELECTRIC BACKUP (3500 WATTS)**

| MODEL      | TRADE PRICE | STOR. CAP. (Gals.) | DESCRIPTION      | MAX. FIRST HOUR RATING Gal./Hr. @ |       | SHP. WGT. (LBS.) |
|------------|-------------|--------------------|------------------|-----------------------------------|-------|------------------|
|            |             |                    |                  | 140°F                             | 115°F |                  |
| H2OI60EDK  | \$2,488     | 60                 | ELECTRIC BACK-UP | 254                               | 333.0 | 135              |
| H2OI80EDK  | \$2,784     | 80                 | ELECTRIC BACK-UP | 266                               | 341.0 | 145              |
| H2OI115EDK | \$3,764     | 115                | ELECTRIC BACK-UP | 319                               | 403.0 | 180              |

**H2O SINGLE COIL STANDARD EQUIPMENT**

**Standard Equipment:** Factory installed brass drain and relief valves, welded stainless steel cold water dip tube factory installed and pressure tested, Honeywell L4080B aquastat for field installation and magnesium anode rod(s).

**H2O SINGLE COIL OPTIONS**

**Options:** (L) Low Profile, (C) Commercial, (HO) High Output, (HOC) High Output Commercial, (XHO) Extra High Output, (E) Electric Backup

**H2O SERIES**  
 STAINLESS STEEL  
 DUAL COIL SOLAR  
 INDIRECT WATER HEATER



**H2O**

**I**

**60**

**D**

**E**

**DK**

I = Indirect

Capacity:  
 60 = 60 Gals.  
 80 = 80 Gals.  
 115 = 115 Gals.

D = Dual Coil

E = Electrical  
 Backup  
 (5500 Watts)

DK = Dunkirk

Conforms to UL STD 174

Certified to CAN/CSA STD C22.2 No. 110-94

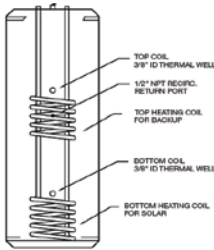
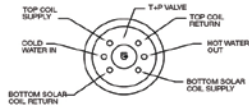

**DUAL COIL UNITS**

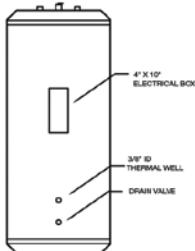
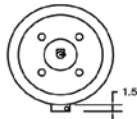

**ELECTRIC BACKUP UNITS**



Note: Max. Working pressure 150 psi for all capacities.

**General Information** (See IOM for complete instructions)

| Model      | Piping Connections NPT (Inches) | Height (Inches) | Dia. (Inches) |
|------------|---------------------------------|-----------------|---------------|
| H2O160DDK  | 1                               | 62.0            | 23.5          |
| H2O180DDK  | 1                               | 56.0            | 28.0          |
| H2O115DDK  | 1                               | 74.0            | 28.0          |
| H2O160DEDK | 1                               | 62.0            | 23.5          |
| H2O180DEDK | 1                               | 56.0            | 28.0          |
| H2O115DEDK | 1                               | 74.0            | 28.0          |

**H2O DUAL COIL STAINLESS STEEL INDIRECT WATER HEATERS CONTINUED**

| MODEL      | TRADE PRICE | STOR. CAP. (Gals.) | DESCRIPTION        | RECOVERY RATE GAL./HR. |             | SHP. WGT. (LBS.) |
|------------|-------------|--------------------|--------------------|------------------------|-------------|------------------|
|            |             |                    |                    | TOP COIL               | BOTTOM COIL |                  |
| H2OI60DDK  | \$2,571     | 60                 | DUAL COIL INDIRECT | 185                    | 214         | 165              |
| H2OI80DDK  | \$2,927     | 80                 | DUAL COIL INDIRECT | 180                    | 214         | 175              |
| H2OI115DDK | \$3,749     | 115                | DUAL COIL INDIRECT | 190                    | 214         | 205              |

**H2O DUAL COIL STAINLESS STEEL INDIRECT WATER HEATERS WITH ELECTRIC BACKUP (3500 WATTS)**

| MODEL       | TRADE PRICE | STOR. CAP. (Gals.) | DESCRIPTION                | RECOVERY RATE GAL./HR. |             | SHP. WGT. (LBS.) |
|-------------|-------------|--------------------|----------------------------|------------------------|-------------|------------------|
|             |             |                    |                            | TOP COIL               | BOTTOM COIL |                  |
| H2OI60DEDK  | \$3,475     | 60                 | DUAL COIL ELECTRIC BACK-UP | 185                    | 214         | 175              |
| H2OI80DEDK  | \$3,924     | 80                 | DUAL COIL ELECTRIC BACK-UP | 180                    | 214         | 185              |
| H2OI115DEDK | \$4,923     | 115                | DUAL COIL ELECTRIC BACK-UP | 190                    | 214         | 215              |

**H2O DUAL COIL STANDARD EQUIPMENT**

**Standard Equipment:** Factory installed brass drain and relief valves, welded stainless steel cold water dip tube factory installed and pressure tested, Honeywell L4080B aquastat for field installation and magnesium anode rod(s). Removable thermal well to accept a solar control thermostat or thermistor. Dual coil units equipped with two aquastat wells which control each coil independently and built-in recirculation tapping. Units with Electric Back-Up are provided with 4" x 10" electrical box with pre-wired heating element, thermostat, and hi-limit. All electric back-up units provided with 240 volt AC, 3500 watt element.

**H2O DUAL COIL OPTIONS**

**Options:** (E) Electric Backup models for supplemental heating.

**H2O SERIES**  
STAINLESS STEEL  
STORAGE TANKS



Conforms to UL STD 174  
Certified to CAN/CSA STD C22.2 No. 110-94

**H2O ST 30 L DK**

ST=Storage Tank

Capacity:  
30 = 30 Gals.  
40 = 40 Gals.  
60 = 60 Gals.  
80 = 80 Gals.  
115 = 115 Gals.

L=Lowboy  
C=Commercial

DK=Dunkirk

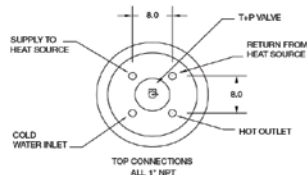

STANDARD UNITS

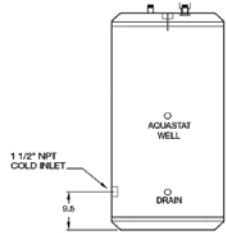
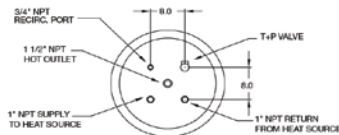

COMMERCIAL UNITS



Note: Max. Working pressure 150 psi for all capacities.

**General Information** (See IOM for complete instructions)

| Model       | Piping Connections NPT |                               | Height (Inches) | Dia. (Inches) |
|-------------|------------------------|-------------------------------|-----------------|---------------|
|             | Supply/Return (Inches) | Heat Source Pressure (Inches) |                 |               |
| H2OST30DK   | 1                      | 1                             | 34.0            | 23.5          |
| H2OST40DK   | 1                      | 1                             | 44.0            | 23.5          |
| H2OST60DK   | 1                      | 1                             | 62.0            | 23.5          |
| H2OST60LDK  | 1                      | 1                             | 46.0            | 23.5          |
| H2OST80DK   | 1                      | 1                             | 56.0            | 28.0          |
| H2OST115DK  | 1                      | 1                             | 74.0            | 28.0          |
| H2OST80CDK  | 1-1/2                  | 1                             | 56.0            | 28.0          |
| H2OST115CDK | 1-1/2                  | 1                             | 74.0            | 28.0          |

## H2O STAINLESS STEEL HOT WATER STORAGE TANKS (NO COIL) CONTINUED

| MODEL                                                                                                                                                                                                           | TRADE PRICE | STOR. CAP.<br>(Gals.) | DESCRIPTION                                      | SHP. WGT. (LBS.) |
|-----------------------------------------------------------------------------------------------------------------------------------------------------------------------------------------------------------------|-------------|-----------------------|--------------------------------------------------|------------------|
| H2OST30DK                                                                                                                                                                                                       | \$1,159     | 30                    | H2O HOT WATER STORAGE TANK<br>(NO COIL)          | 75               |
| H2OST40DK                                                                                                                                                                                                       | \$1,197     | 40                    | H2O HOT WATER STORAGE TANK<br>(NO COIL)          | 90               |
| H2OST60DK                                                                                                                                                                                                       | \$1,746     | 60                    | H2O HOT WATER STORAGE TANK<br>(NO COIL)          | 115              |
| H2OST60LDK                                                                                                                                                                                                      | \$1,801     | 60                    | LOW BOY H2O HOT WATER<br>STORAGE TANKS (NO COIL) | 110              |
| H2OST80DK                                                                                                                                                                                                       | \$1,983     | 80                    | H2O HOT WATER STORAGE TANKS<br>(NO COIL)         | 140              |
| H2OST80CDK                                                                                                                                                                                                      | \$2,856     | 80                    | COMM. H2O HOT WATER STORAGE<br>TANK (NO COIL)    | 175              |
| H2OST115DK                                                                                                                                                                                                      | \$2,182     | 115                   | H2O HOT WATER STORAGE TANK<br>(NO COIL)          | 140              |
| H2OST115CDK                                                                                                                                                                                                     | \$3,056     | 115                   | COMM. H2O HOT WATER STORAGE<br>TANK (NO COIL)    | 175              |
| <b>H2O STORAGE TANK STANDARD EQUIPMENT</b>                                                                                                                                                                      |             |                       |                                                  |                  |
| <b>Standard Equipment:</b> Factory installed brass drain and relief valves, welded stainless steel cold water dip tube factory installed and pressure tested, Honeywell L4080B aquastat for field installation. |             |                       |                                                  |                  |
| <b>H2O STORAGE TANK OPTIONS</b>                                                                                                                                                                                 |             |                       |                                                  |                  |
| <b>Options:</b> (C) Commercial, (L) Low Profile                                                                                                                                                                 |             |                       |                                                  |                  |

**H2O SERIES**  
STAINLESS STEEL  
BUFFER TANKS

**H2O BT 40 114 WC DK**



Conforms to UL STD 174  
Certified to CAN/CSA STD C22.2 No. 110-94

BT = Buffer Tank

Capacity:  
22= 22 Gals.  
40= 40 Gals.  
60= 60 Gals.  
80= 80 Gals.

114= 1-1/4" NPT  
112= 1-1/2" NPT  
2= 2" NPT

WC= With Coil

DK= Dunkirk

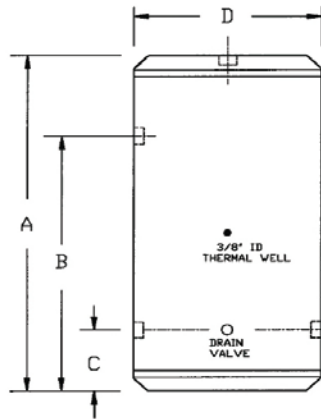

4 CONNECTIONS  
1 ON RIGHT SIDE  
2 ON LEFT SIDE  
1 ON TOP



Note: Max. Working pressure 150 psi for all capacities.

**General Information** (See IOM for complete instructions)

| Model           | Piping Connections NPT (Inches) | Height (Inches) | B (Inches) | C (Inches) |
|-----------------|---------------------------------|-----------------|------------|------------|
| H2OBT22114DK    | 1-1/4                           | 24.5            | 15         | 8          |
| H2OBT40114DK    | 1-1/4                           | 42.0            | 31.0       | 11.0       |
| H2OBT40112DK    | 1-1/2                           |                 |            |            |
| H2OBT402DK      | 2                               |                 |            |            |
| H2OBT60114DK    | 1-1/4                           | 44.0            | 31.5       | 11.5       |
| H2OBT60112DK    | 1-1/2                           |                 |            |            |
| H2OBT602DK      | 2                               |                 |            |            |
| H2OBT80114DK    | 1-1/4                           | 54.0            | 40.5       | 11.5       |
| H2OBT80112DK    | 1-1/2                           |                 |            |            |
| H2OBT802DK      | 2                               |                 |            |            |
| H2OBT115114DK   | 1-1/4                           | 72.0            | 61.5       | 11.5       |
| H2OBT115112DK   | 1-1/2                           |                 |            |            |
| H2OBT1152DK     | 2                               |                 |            |            |
| H2OBT40114WCDK  | 1-1/4                           | 42.0            | 31.0       | 11.0       |
| H2OBT40112WCDK  | 1-1/2                           |                 |            |            |
| H2OBT402WCDK    | 2                               |                 |            |            |
| H2OBT60114WCDK  | 1-1/4                           | 44.0            | 31.5       | 11.5       |
| H2OBT60112WCDK  | 1-1/2                           |                 |            |            |
| H2OBT602WCDK    | 2                               |                 |            |            |
| H2OBT80114WCDK  | 1-1/4                           | 54.0            | 40.5       | 11.5       |
| H2OBT80112WCDK  | 1-1/2                           |                 |            |            |
| H2OBT802WCDK    | 2                               |                 |            |            |
| H2OBT115114WCDK | 1-1/4                           | 72.0            | 61.5       | 11.5       |
| H2OBT115112WCDK | 1-1/2                           |                 |            |            |
| H2OBT1152WCDK   | 2                               |                 |            |            |

**H2O HYDRONIC STAINLESS STEEL BUFFER TANKS CONTINUED**

| MODEL         | TRADE PRICE | STOR. CAP. (Gals.) | DESCRIPTION          | SHP. WGT. (LBS.) |
|---------------|-------------|--------------------|----------------------|------------------|
| H2OBT22114DK  | \$1,161     | 22                 | HYDRONIC BUFFER TANK | 35               |
| H2OBT40114DK  | \$2,031     | 40                 | HYDRONIC BUFFER TANK | 87               |
| H2OBT40112DK  | \$2,031     |                    |                      |                  |
| H2OBT402DK    | \$2,031     |                    |                      |                  |
| H2OBT60114DK  | \$2,419     | 60                 | HYDRONIC BUFFER TANK | 115              |
| H2OBT60112DK  | \$2,419     |                    |                      |                  |
| H2OBT602DK    | \$2,419     |                    |                      |                  |
| H2OBT80114DK  | \$2,670     | 80                 | HYDRONIC BUFFER TANK | 125              |
| H2OBT80112DK  | \$2,670     |                    |                      |                  |
| H2OBT802DK    | \$2,670     |                    |                      |                  |
| H2OBT115114DK | \$3,324     | 115                | HYDRONIC BUFFER TANK | 160              |
| H2OBT115112DK | \$3,324     |                    |                      |                  |
| H2OBT1152DK   | \$3,324     |                    |                      |                  |

**H2O HYDRONIC BUFFER TANKS (WITH COIL)**

| MODEL           | TRADE PRICE | STOR. CAP. (Gals.) | DESCRIPTION                      | SHP. WGT. (LBS.) |
|-----------------|-------------|--------------------|----------------------------------|------------------|
| H2OBT40114WCDK  | \$2,604     | 40                 | HYDRONIC BUFFER TANK (WITH COIL) | 97               |
| H2OBT40112WCDK  | \$2,604     |                    |                                  |                  |
| H2OBT402WCDK    | \$2,604     |                    |                                  |                  |
| H2OBT60114WCDK  | \$2,769     | 60                 | HYDRONIC BUFFER TANK (WITH COIL) | 125              |
| H2OBT60112WCDK  | \$2,769     |                    |                                  |                  |
| H2OBT602WCDK    | \$2,769     |                    |                                  |                  |
| H2OBT80114WCDK  | \$3,303     | 80                 | HYDRONIC BUFFER TANK (WITH COIL) | 135              |
| H2OBT80112WCDK  | \$3,303     |                    |                                  |                  |
| H2OBT802WCDK    | \$3,303     |                    |                                  |                  |
| H2OBT115114WCDK | \$4,020     | 115                | HYDRONIC BUFFER TANK (WITH COIL) | 170              |
| H2OBT115112WCDK | \$4,020     |                    |                                  |                  |
| H2OBT1152WCDK   | \$4,020     |                    |                                  |                  |

**H2O BUFFER TANK STANDARD EQUIPMENT**

**Standard Equipment:** Factory installed brass drain and relief valves, welded stainless steel cold water dip tube factory installed and pressure tested, Honeywell L4080B aquastat for field installation.

**H2O BUFFER TANK OPTIONS**

**Options:** (WC) With Coil



HOTLINE SERIES

INDIRECT WATER HEATER

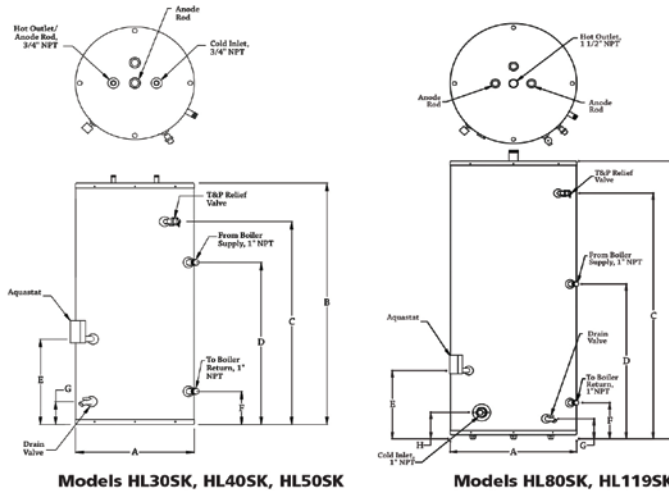

Note: Max. Working pressure 150 psi for all capacities.

General Information (See IOM for complete instructions)

| Model     | Piping Connections NPT            |                                 | A<br>Dia.<br>(Inches) | B<br>Height<br>(Inches) |
|-----------|-----------------------------------|---------------------------------|-----------------------|-------------------------|
|           | Domestic Water<br>In/Out (Inches) | Boiler Water<br>In/Out (Inches) |                       |                         |
| *ST00211D | 3/4                               | 1                               | 22.0                  | 35-3/4                  |
| ST00215D  | 3/4                               | 1                               | 22.0                  | 42-3/4                  |
| ST00212D  | 3/4                               | 1                               | 22.0                  | 48-3/4                  |
| ST00213D  | 1                                 | 1                               | 24.0                  | 64-3/4                  |
| ST00214D  | 1                                 | 1                               | 28.0                  | 65-1/4                  |

HOTLINE INDIRECT WATER HEATERS

| MODEL     | NAME    | TRADE PRICE | STOR. CAP. (Gals.) | BTU/H MIN. BOILER OUTPUT | MAX 1ST HR FLOW RATINGS GAL./HR. | SHP. WGT. (LBS.) |
|-----------|---------|-------------|--------------------|--------------------------|----------------------------------|------------------|
| *ST00211D | HL30SK  | \$1,158     | 30                 | 74                       | 115                              | 140              |
| ST00215D  | HL40SK  | \$1,275     | 40                 | 74                       | 125                              | 200              |
| ST00212D  | HL50SK  | \$1,405     | 50                 | 74                       | 140                              | 220              |
| ST00213D  | HL80SK  | \$2,004     | 80                 | 150                      | 185                              | 286              |
| ST00214D  | HL119SK | \$2,457     | 119                | 175                      | 250                              | 372              |

\*SURFACE MOUNTED THERMOSTAT.

HOTLINE OPTIONS/ADDITIONAL EQUIPMENT

|                                         | PN      | TRADE |
|-----------------------------------------|---------|-------|
| MAGNESIUM ANODE 3/4 X 30; 30-40-50 GAL. | ST00301 | \$63  |
| MAGNESIUM ANODE 3/4 X 36; 80 GAL.       | ST00701 | \$51  |
| MAGNESIUM ANODE 3/4 X 36; 119 GAL.      | ST00901 | \$42  |
| DIP TUBE 3/4 X 3 X 33; 30 GAL.          | ST00401 | \$72  |
| DIP TUBE 3/4 X 3 X 38; 40 GAL.          | ST01301 | \$16  |
| DIP TUBE 3/4 X 3 X 44; 50 GAL.          | ST00801 | \$31  |
| T & P VALVE 3/4, LL100XL; 30-40-50 GAL. | ST00601 | \$37  |
| T & P VALVE 3/4, 140X5; 80-119 GAL.     | ST01001 | \$90  |
| AQUASTAT L4080B1352                     | ST01101 | \$324 |

HOTLINE INDIRECT WATER HEATER STANDARD EQUIPMENT

**STANDARD EQUIPMENT:** Factory Assembled Hot Water Tank; Steel Tank with 2" Foam Insulation; Smooth Coil Coated with Porcelain to resist Corrosion and Lime Build-Up; Replaceable Magnesium Anode Rod Aquastat Limit Control; Self Cleaning Drain Valve; Factory Installed T & P Valve.