



US Trade Price Book - 2021

Effective 1/1/21



Simple. Comfortable. Affordable.



www.pennco boilers.com



Manufactured by:
ECR International Inc.
2201 Dwyer Avenue, Utica, NY 13501
Tel. 800 325 5479
www.ecrinternational.com
PN 240004966 REV. H [01/01/2021]



CUSTOMER SUPPORT TEAM

CUSTOMER SERVICE:

Phone: (800) 325-5479 option #2
Fax: (315) 724-9319
Email Purchase Orders: ecrorderentry@ecrinternational.com
Email Inquiries: customerservice@ecrinternational.com

TECHNICAL SUPPORT:

Phone: (800) 253-7900
Fax: (866) 432-7329
Email: technical.support@ecrinternational.com

MARKETING SUPPORT:

Phone: (800) 325-5479
Fax: (315) 733-1759
E-mail: marketing@ecrinternational.com

WWW.ECRCUSTOMERPORTAL.COM

Your On-line Access to:

- Order Status
- Invoices
- Statements
- RMA
- Serial Number Look-Up
- Literature

Table of Contents

Condensing Natural / LP Boilers		4-5
P90	Cast Aluminum Floor Standing Heating Boilers (50-100 MBH)	4
Natural / LP Boilers		6-13
15B-K	Cast Iron Chimney Vented Boilers (59-235 MBH)	6
FSB	Cast Iron Induced Draft Chimney/Side Wall Vented Boilers (42-187 MBH)	8
16	Cast Iron Steam Boilers (75-299 MBH)	10
41K	Cast Iron Commercial Steam Boilers (300-1,500 MBH)	12
Oil Boilers		14-17
KWC	Cast Iron Chimney Vented Boilers (112-217 MBH)	14
SBO	Cast Iron Steam Boilers (119-210 MBH)	16
Indirect Tanks		18-20
H2O GL	Single Coil Glass Lined Indirect Water Heaters (31-106 GALS)	18
Terms & RMA Policy		20-21



P90 Cast-Aluminum Floor Standing Heating Boilers

- MBH Input 50 - 100 (CH)
- 90% AFUE
- Natural or LP Gas
- High Efficiency Cast Aluminum Heat Exchanger
- Fuel Smart Hydrostat Control: Temperature Limit
- Low Water Cut Off (LWCO)
- Boiler Reset
- Compact Design, Floor Standing Design
- Stainless Steel Premix Burner
- Sealed Combustion
- Induced Draft Blower with Adjustable Exhaust

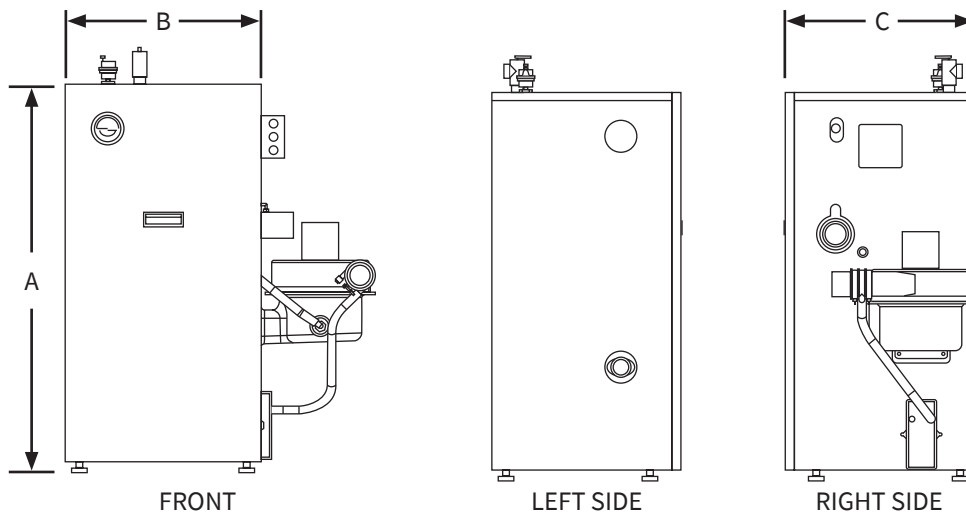

General Information (See IOM for Complete Instructions)			
Model	P90-050	P90-075	P90-100
Water Return/Supply	1 1/4" NPT		
Gas	1/2" NPT		
Condensate Drain	1/2" CPVC Stub		
Electrical	120 Volts AC, 60 hertz, 1 phase, less than 12 amps(15 amp circuit recommended)		
Water Content (Gallons)	2.6		
Dimensions	A-Height	36 1/4"	
	B-Width	17 3/4"	
	C-Depth	17 3/8"	
Weight	220 lbs		



P90 - Cast Aluminum Floor Standing Heating Boilers								
Model	Item Number	Input MBH	AHRI Net MBH	AFUE	Fuel	Pump	Shp. Wgt. Lbs	Trade Price
P90-50	Q90205003200407	50	39	90.0%	NAT	LESS	256	\$3,342
P90-75	Q90207503200407	75	59	90.0%	NAT	LESS	256	\$3,342
P90-100	Q90210003200407	100	78	90.0%	NAT	LESS	256	\$3,342
P90-50	Q90205003210407	50	39	90.0%	NAT	TACO	256	\$3,410
P90-75	Q90207503210407	75	59	90.0%	NAT	TACO	256	\$3,410
P90-100	Q90210003210407	100	78	90.0%	NAT	TACO	256	\$3,410
P90-50	Q90205003220407	50	39	90.0%	NAT	GRUNDFOS	256	\$3,410
P90-75	Q90207503220407	75	59	90.0%	NAT	GRUNDFOS	256	\$3,410
P90-100	Q90210003220407	100	78	90.0%	NAT	GRUNDFOS	256	\$3,410
P90-50	Q90205013200407	50	39	90.0%	LP	LESS	256	\$3,342
P90-75	Q90207513200407	75	59	90.0%	LP	LESS	256	\$3,342
P90-100	Q90210013200407	100	78	90.0%	LP	LESS	256	\$3,342
P90-50	Q90205013210407	50	39	90.0%	LP	TACO	256	\$3,410
P90-75	Q90207513210407	75	59	90.0%	LP	TACO	256	\$3,410
P90-100	Q90210013210407	100	78	90.0%	LP	TACO	256	\$3,410
P90-50	Q90205013220407	50	39	90.0%	LP	GRUNDFOS	256	\$3,410
P90-75	Q90207513220407	75	59	90.0%	LP	GRUNDFOS	256	\$3,410
P90-100	Q90210013220407	100	78	90.0%	LP	GRUNDFOS	256	\$3,410
P90 (Use Parts Multiplier for All of the Following)								
Model	Item Number	Description						Trade Price
P90-100	29571	CONCENTRIC VENT KIT 3"						\$240
P90-100	29570	CONCENTRIC VENT KIT 2"						\$240
P90-50	550002631	CONVERSION KIT NAT. TO LP P90-50 (Series IV) 0' - 10,000'						\$83
P90-75	550002629	CONVERSION KIT NAT. TO LP P90-75 (Series IV) 5,000' - 10,000'						\$83
P90-75	550002630	CONVERSION KIT NAT. TO LP P90-75 (Series IV) 0' - 5,000'						\$83
P90-100	550002700	CONVERSION KIT NAT. TO LP P90-100 (Series IV) 0' - 10,000'						\$83
P90-50	550002635	CONVERSION KIT LP TO NAT. P90-50 (Series IV) 0' - 10,000'						\$83
P90-75	550002634	CONVERSION KIT LP TO NAT. P90-75 (Series IV) 0' - 10,000'						\$83
P90-100	550002701	CONVERSION KIT LP TO NAT. P90-100 (Series IV) 0' - 10,000'						\$83
P90-100	14624002	FILL-TROL #110 FOR WATER BOILERS 150 MBH OR LESS						\$321
P90-100	14624003	FILL-TROL #111 FOR WATER BOILERS OVER 150 MBH						\$445
P90 - Venting (Use Parts Multiplier for All of the Following)								
Image	Item Number	Description						Trade Price
	240009663	2" CPVC 90° ELBOW						\$29
	240006819	2" CPVC TEE, SCHEDULE 80						\$40
	240006822	2" CPVC COUPLING						\$26

15B-K Cast-Iron Chimney Vented Boilers

- MBH Input 59 - 235 (CH)
- 84% AFUE
- Dependable Cast Iron Heat Exchanger
- Honeywell Control
- Digital temperature display and diagnostics
- Built-In Low Water Cut-Off (LWCO)
- Control monitors water temperature and delays burner start until residual heat has been transferred to the system for maximum efficiency.
- Low Profile draft hood diverter



General Information (See IOM for Complete Instructions)							
Model	15B-060K	15B-095K	15B-120K	15B-150K	15B-175K	15B-205K	15B-235K
Water Return/Supply	1 1/4" NPT						
Gas	1/2" NPT				3/4" NPT		
Electrical	120 Volts AC, 60 hertz, 1 phase, less than 12 amps (15 amp circuit recommended)						
Water Content (Gallons)	1.9	2.3	2.8	3.2	3.7	4.1	4.6
A-Height	32 1/8"	32 1/8"	32 1/8"	32 1/8"	32 1/8"	32 1/8"	32 1/8"
B-Width	13 3/8"	13 3/8"	16 1/4"	19"	21 7/8"	27 1/2"	27 1/2"
C-Depth	24 1/8"	24 1/8"	24 1/8"	24 1/8"	24 1/8"	24 1/8"	24 1/8"
Weight	215	250	295	335	385	420	465

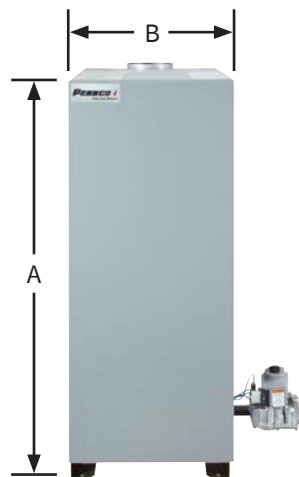

FRONT



RIGHT SIDE

15B-K - Cast Iron Chimney Vented Boilers									
Model	Item Number	Input MBH	Htg. Cap. MBH	AHRI Net MBH	AFUE	Fuel	Pump	Shp. Wgt. lbs	Trade Price
15B-060K	15B306003700307	59	50	43	84.0%	NAT	LESS	215	\$1,971
15B-095K	15B409503700307	92.5	78	68	84.0%	NAT	LESS	245	\$2,171
15B-120K	15B512003700307	120	101	88	84.0%	NAT	LESS	305	\$2,343
15B-150K	15B615003700307	149	125	109	84.0%	NAT	LESS	335	\$2,635
15B-175K	15B717503700307	175	148	129	84.0%	NAT	LESS	395	\$2,917
15B-205K	15B820503700307	205	172	150	84.0%	NAT	LESS	435	\$3,295
15B-235K	15B923503700307	235	197	172	84.0%	NAT	LESS	465	\$3,600
15B-060K	15B306003710307	59	50	43	84.0%	NAT	TACO	215	\$2,117
15B-095K	15B409503710307	92.5	78	68	84.0%	NAT	TACO	245	\$2,318
15B-120K	15B512003710307	120	101	88	84.0%	NAT	TACO	305	\$2,491
15B-150K	15B615003710307	149	125	109	84.0%	NAT	TACO	335	\$2,782
15B-175K	15B717503710307	175	148	129	84.0%	NAT	TACO	395	\$3,063
15B-205K	15B820503710307	205	172	150	84.0%	NAT	TACO	435	\$3,441
15B-235K	15B923503710307	235	197	172	84.0%	NAT	TACO	465	\$3,745
15B-060K	15B306003720307	59	50	43	84.0%	NAT	GRUNDFOS	215	\$2,117
15B-095K	15B409503720307	92.5	78	68	84.0%	NAT	GRUNDFOS	245	\$2,318
15B-120K	15B512003720307	120	101	88	84.0%	NAT	GRUNDFOS	305	\$2,491
15B-150K	15B615003720307	149	125	109	84.0%	NAT	GRUNDFOS	335	\$2,782
15B-175K	15B717503720307	175	148	129	84.0%	NAT	GRUNDFOS	395	\$3,063
15B-205K	15B820503720307	205	172	150	84.0%	NAT	GRUNDFOS	435	\$3,441
15B-235K	15B923503720307	235	197	172	84.0%	NAT	GRUNDFOS	465	\$3,745
15B-060K	15B306013700307	59	50	43	84.0%	LP	LESS	215	\$2,000
15B-095K	15B409513700307	92.5	78	68	84.0%	LP	LESS	245	\$2,190
15B-120K	15B512013700307	120	101	88	84.0%	LP	LESS	305	\$2,360
15B-150K	15B615013700307	149	125	109	84.0%	LP	LESS	335	\$2,700
15B-175K	15B717513700307	175	148	129	84.0%	LP	LESS	395	\$2,975
15B-205K	15B820513700307	205	172	150	84.0%	LP	LESS	435	\$3,300
15B-235K	15B923513700307	235	197	172	84.0%	LP	LESS	465	\$3,610
15B-060K	15B306013710307	59	50	43	84.0%	LP	TACO	215	\$2,175
15B-095K	15B409513710307	92.5	78	68	84.0%	LP	TACO	245	\$2,400
15B-120K	15B512013710307	120	101	88	84.0%	LP	TACO	305	\$2,550
15B-150K	15B615013710307	149	125	109	84.0%	LP	TACO	335	\$2,813
15B-175K	15B717513710307	175	148	129	84.0%	LP	TACO	395	\$3,100
15B-205K	15B820513710307	205	172	150	84.0%	LP	TACO	435	\$3,449
15B-235K	15B923513710307	235	197	172	84.0%	LP	TACO	465	\$3,753
15B-060K	15B306013720307	59	50	43	84.0%	LP	GRUNDFOS	215	\$2,175
15B-095K	15B409513720307	92.5	78	68	84.0%	LP	GRUNDFOS	245	\$2,400
15B-120K	15B512013720307	120	101	88	84.0%	LP	GRUNDFOS	305	\$2,550
15B-150K	15B615013720307	149	125	109	84.0%	LP	GRUNDFOS	335	\$2,813
15B-175K	15B717513720307	175	148	129	84.0%	LP	GRUNDFOS	395	\$3,100
15B-205K	15B820513720307	205	172	150	84.0%	LP	GRUNDFOS	435	\$3,449
15B-235K	15B923513720307	235	197	172	84.0%	LP	GRUNDFOS	465	\$3,753
15B-K (Use Parts Multiplier for All of the Following)									
Model	Item Number	Description							Trade Price
ALL MODELS	550003778	NATURAL GAS TO LP GAS CONVERSION KIT							\$74
ALL MODELS	550003884	LP GAS TO NATURAL GAS CONVERSION KIT							\$81

FSB Cast-Iron Induced Draft Chimney/Side Wall Vented Boilers

- MBH Input 42 - 187 (CH)
- Up to 84.4% AFUE
- Dependable Cast Iron Heat Exchanger with Cast Iron Push Nipples
- Honeywell High Limit/Electronic Ignition Control
 - Recessed under the boiler's protective jacket
 - Digital Temperature display and diagnostics
 - Plug in connection for the inducer fan
 - Plug in connection for the system pump
- Induced Draft Fan



General Information (See IOM for Complete Instructions)						
Model	FSB-2	FSB-3	FSB-4	FSB-5	FSB-6	
Water Return/Supply	1 1/4" NPT					
Gas	1/2" NPT					
Electrical	120 Volts AC, 60 hertz, 1 phase, less than 12 amps (15 amp circuit recommended)					
Water Content (Gallons)	1.75	3.00	4.25	5.50	6.75	
Dimensions	A-Height	29"	29"	29"	29"	
	B-Width	11"	14 1/4"	17 1/2"	20 3/4"	24"
	C-Depth	23 1/4"	23 1/4"	23 1/4"	23 1/4"	23 1/4"
Weight	225 lbs	265 lbs	322 lbs	370 lbs	431 lbs	

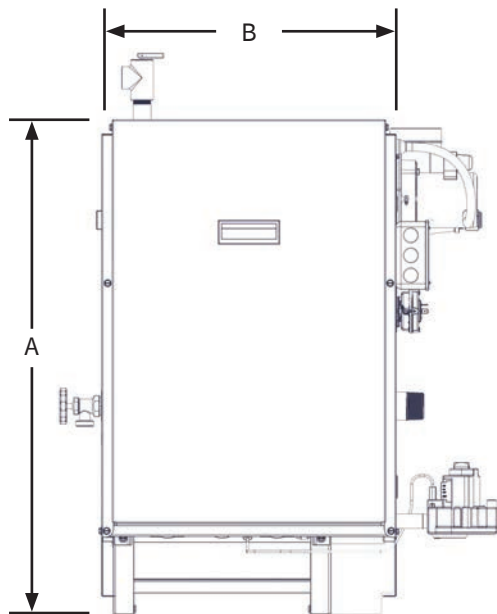

FRONT

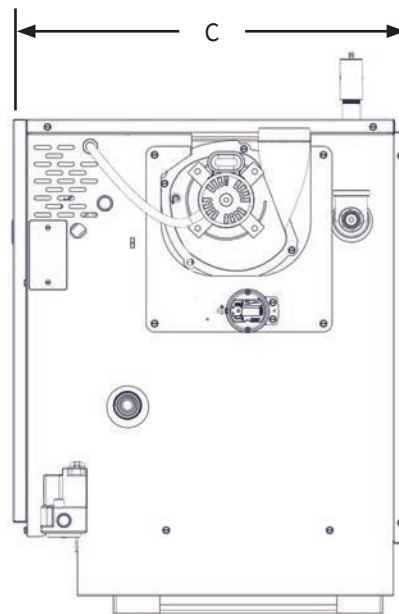

RIGHT SIDE

FSB - Cast Iron Induced Draft Chimney/Side Wall Vented Boilers									
Model	Item Number	Input MBH	Htg. Cap. MBH	AHRI Net MBH	AFUE	Fuel	Pump	Shp. Wgt. Lbs	Trade Price
FSB-2	FSB204203110307	42.5	36	31	84.4%	NAT	TACO	225	\$2,259
FSB-3	FSB307503110307	75	63	55	84.0%	NAT	TACO	265	\$2,548
FSB-4	FSB411203110307	112.5	95	82	84.0%	NAT	TACO	322	\$2,810
FSB-5	FSB515003110307	150	127	109	84.0%	NAT	TACO	370	\$3,145
FSB-6	FSB618703110307	187.5	158	135	84.0%	NAT	TACO	431	\$3,682
FSB-2	FSB204203120307	42.5	36	31	84.4%	NAT	GRUNDFOS	225	\$2,259
FSB-3	FSB307503120307	75	63	55	84.0%	NAT	GRUNDFOS	265	\$2,548
FSB-4	FSB411203120307	112.5	95	82	84.0%	NAT	GRUNDFOS	322	\$2,810
FSB-5	FSB515003120307	150	127	109	84.0%	NAT	GRUNDFOS	370	\$3,145
FSB-6	FSB618703120307	187.5	158	135	84.0%	NAT	GRUNDFOS	431	\$3,682
FSB-2	FSB204213110307	42.5	36	31	84.4%	LP	TACO	225	\$2,313
FSB-3	FSB307513110307	75	63	55	84.0%	LP	TACO	265	\$2,600
FSB-4	FSB411213110307	112.5	95	82	84.0%	LP	TACO	322	\$2,865
FSB-5	FSB515013110307	150	127	109	84.0%	LP	TACO	370	\$3,200
FSB-6	FSB618713110307	187.5	158	135	84.0%	LP	TACO	431	\$3,738
FSB-2	FSB204213120307	42.5	36	31	84.4%	LP	GRUNDFOS	225	\$2,313
FSB-3	FSB307513120307	75	63	55	84.0%	LP	GRUNDFOS	265	\$2,600
FSB-4	FSB411213120307	112.5	95	82	84.0%	LP	GRUNDFOS	322	\$2,865
FSB-5	FSB515013120307	150	127	109	84.0%	LP	GRUNDFOS	370	\$3,200
FSB-6	FSB618713120307	187.5	158	135	84.0%	LP	GRUNDFOS	431	\$3,738
FSB (Use Parts Multiplier for All of the Following)									
Model	Item Number	Description							Trade Price
FSB	550002722	NATURAL TO LP CONVERSION KIT (ALL SIZES)							\$91
FSB	43300660	LP TO NATURAL CONVERSION KIT (ALL SIZES)							\$100
Side Wall Vent Hoods									
FSB	14629010	TJERNLUND VH-1-3" SIDE WALL VENT HOOD (FSB-2 TO FSB-5)							\$253
FSB	14629011	TJERNLUND VH-1-4" SIDE WALL VENT HOOD (FSB-6)							\$301

16 Cast-Iron Steam Boilers

- MBH Input 75 - 299 (CH)
- Up to 82.7% AFUE
- 7 Sizes Available
- Dependable Cast-Iron Heat Exchanger
- Electronic Ignition System
- Automatic Vent Damper
- LWCO (Probe Type) externally mounted for quick access
- Pressure High Limit Control with Pressure Gauge and Gauge Glass
- Stainless Steel Burners
- Easy Serviceability



General Information (See IOM for Complete Instructions)							
Model	1603HSID	1604HSID	1605HSID	1606HSID	1607HSID	1608HSID	1609HSID
Steam Return/Supply	2 1/2" NPT						
Electrical	120 Volts AC, 60 hertz, 1 phase, less than 12 amps (15 amp circuit recommended)						
A-Height	36 3/8"	36 3/8"	36 3/8"	36 3/8"	36 3/8"	36 3/8"	36 3/8"
B-Width	11 1/4"	14 1/2"	17 3/4"	21"	24 1/4"	27 1/2"	30 3/4"
C-Depth	26 1/2"	26 1/2"	26 1/2"	26 1/2"	26 1/2"	26 1/2"	26 1/2"
Weight	297 lbs.	368 lbs.	440 lbs.	512 lbs.	584 lbs.	659 lbs.	736 lbs.

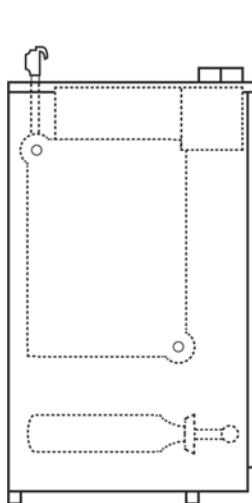

LEFT SIDE

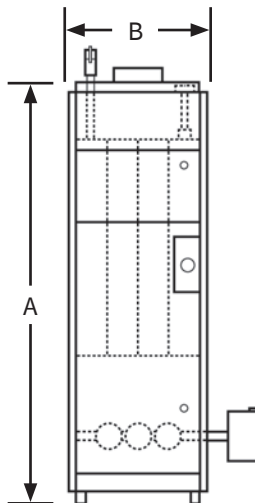

FRONT

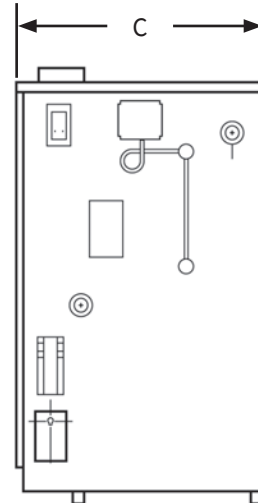

RIGHT SIDE

16 - Cast Iron Steam Boilers									
Model	Item Number	Input MBH	Htg. Cap. MBH	AHRI Net MBH	AHRI Net SQ. FT. Steam	AFUE	Fuel	Shp. Wgt. lbs	Trade Price
1603HSID	353541106	75	62	47	196	82.7%	NAT	297	\$2,546
1604HSID	354541106	112	91	68	183	82.0%	NAT	368	\$2,848
1605HSID	355541106	150	122	92	383	82.0%	NAT	440	\$3,182
1606HSID	356541106	187	153	115	479	82.0%	NAT	512	\$3,637
1607HSID	357541106	225	183	137	571	82.0%	NAT	584	\$4,061
1608HSID	358541106	262	214	161	671	82.0%	NAT	659	\$4,487
1609HSID	359541106	299	245	184	767	82.0%	NAT	736	\$4,780

16 (Use Parts Multiplier for All of the Following)			
Model	Item Number	Description	Trade Price
1603HSID	43300723	3 SECTION NATURAL GAS TO LP GAS CONVERSION KIT	\$54
1604HSID	43300724	4 SECTION NATURAL GAS TO LP GAS CONVERSION KIT	\$54
1605HSID	43300725	5 SECTION NATURAL GAS TO LP GAS CONVERSION KIT	\$54
1606HSID	43300726	6 SECTION NATURAL GAS TO LP GAS CONVERSION KIT	\$64
1607HSID	43300727	7 SECTION NATURAL GAS TO LP GAS CONVERSION KIT	\$64
1608HSID	43300728	8 SECTION NATURAL GAS TO LP GAS CONVERSION KIT	\$64
1609HSID	43300729	9 SECTION NATURAL GAS TO LP GAS CONVERSION KIT	\$64
1604HSID	43300632	4 SECTION LP GAS TO NATURAL GAS CONVERSION KIT	\$202
1605HSID	43300633	5 SECTION LP GAS TO NATURAL GAS CONVERSION KIT	\$205
1606HSID	43300634	6 SECTION LP GAS TO NATURAL GAS CONVERSION KIT	\$200
1607HSID	43300635	7 SECTION LP GAS TO NATURAL GAS CONVERSION KIT	\$202
1608HSID	43300636	8 SECTION LP GAS TO NATURAL GAS CONVERSION KIT	\$203
1609HSID	43300637	9 SECTION LP GAS TO NATURAL GAS CONVERSION KIT	\$203
	1630001	WF2 WATER FEEDER USED WITH PS802 LWCO	\$512

41K Cast-Iron Commercial Steam Boilers

41K Commercial Boiler Bases are pre-assembled at the factory with burner manifold, burner orifices, gas valves and electronic ignition installed; ready for field installation of the pre-tested sections and appropriate packages.

Electronic Ignition Base Standard Equipment:

- Base
- Fire Door
- Burner Orifice
- Manifold
- Main and Pilot Burner
- Electronic Pilot Gas Valve
- Intermittent Pilot Module
- Complete Jacket Assembly

Steam Trim Package:

- Low Water Cut-Off
- Glass Gauge Set
- Safety Valve
- Steam Gauge
- Pressure Limit
- Drain Valve



Plug 'N Play Harness and Junction Box

Individual base and junction box controls are designed for easy installation. The entire boiler links together in a snap with a color-coded factory supplied wiring harness.

General Information (See IOM for Complete Instructions)

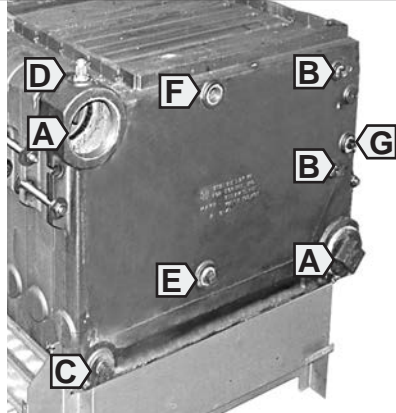
	Right & Left End Tappings	Opening	Size
	Return/Supply	A	4"
	Primary LWCO & Guage Glass Set	B	1/2"
	Drain, Left End	C	3/4"
	Drain, Right End	C	3/4"
	Plugged	D	1/2"
	Accessories	E	1"
	Safety Valve	F*	1"
	Plugged or Electronic (Probe Type) LWCO	G	3/4"
	*If using opening F for other than Safety Valve or Safety Relief Valve, or Safety/Relief valve is larger than 1", Install Safety/Relief Valve in Header Piping as near boiler as possible.		

41K - Cast Iron Commercial Steam Boilers

Model	Item Number	Input MBH	Output MBH	Net AHRI Ratings			Therm. Eff.	Shp. Wgt. Lbs	No. of Sect.	Trade Price
				Steam PPF	Steam SQ. FT.	Steam BTU (MBH)				
41K300S	CBA030003101107	300	233	1.33	729	175	77.0%	1000	4	\$8,859
41K400S	CBA040003101107	400	310	1.33	971	233	77.0%	1200	5	\$9,967
41K500S	CBA050003101107	500	388	1.33	1213	291	77.0%	1400	6	\$11,081
41K600S	CBA060003101107	600	465	1.33	1454	349	77.0%	1600	7	\$14,409
41K700S	CBA070003101107	700	543	1.33	1696	407	77.0%	1800	8	\$15,522
41K800S	CBA080003101107	800	620	1.33	1938	465	77.0%	2000	9	\$16,677
41K900S	CBA090003101107	900	698	1.33	2183	524	77.0%	2200	10	\$17,896
41K1000S	CBA100003101107	1000	775	1.33	2421	581	77.0%	2400	11	\$19,004
41K1100S	CBA110003101107	1100	853	1.33	2667	640	77.0%	2600	12	\$22,421
41K1200S	CBA120003101107	1200	930	1.33	2908	698	77.0%	2900	13	\$23,530
41K1300S	CBA130003101107	1300	1008	1.33	3150	756	77.0%	3100	14	\$25,289
41K1400S	CBA140003101107	1400	1085	1.33	3392	814	77.0%	3300	15	\$26,403
41K1500S	CBA150003101107	1500	1163	1.33	3633	872	77.0%	3500	16	\$27,539

41K (Use Parts Multiplier for All of the Following)

Model	Item Number	Description	Trade Price
41K	14662311	STEAM MANUAL RESET PRESSURE CONTROL (L4079B1033)	\$293
41K	1280001	M-M 47-2 LWCO & FEEDER (MODELS 300-1500)	\$1,318
41K	14662313	STRAP ON OPERATING CONTROL (L6006C-1034)	\$176

KWC Cast-Iron Chimney Vented Boilers

- MBH Input 112 - 217
- Up to 86.2% AFUE
- Advanced High Efficiency Heat Exchanger Design
- Hydrolevel Control:
 - Hydrolevel 3250: with digital display and diagnostics; adjusts the water temperature based on your heating system demand which further reduces your heating costs. It also features a built-in low water cut-off (LWCO) to protect the boiler from potentially dangerous low water conditions.
- Compact Footprint
- Easy Serviceability



General Information (See IOM for Complete Instructions)					
Model		3KWC	4KWC	5KWC	
Water Return/Supply		1 1/4" NPT			
Drain Valve		3/4" NPT			
Electrical		120 Volts AC, 60 hertz, 1 phase, less than 12 amps (15 amp circuit recommended)			
Water Content (Gallons)		9.6	11.6	13.7	
Dimensions	A-Height	36"	36"	36"	
	B-Width	20 1/2"	20 1/2"	20 1/2"	
	C-Depth	14 1/2"	17 3/4"	21"	
Weight		470 lbs.	545 lbs.	630 lbs.	

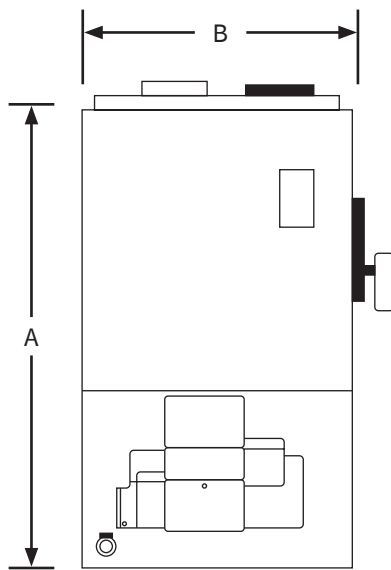

FRONT

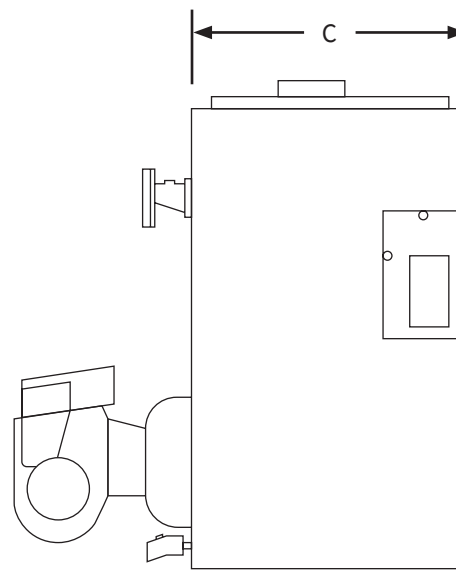

RIGHT SIDE

KWC - Cast Iron Chimney Vented Oil Boilers with Beckett Burner												
Model	Item Number	Input MBH	Htg. Cap. MBH	AHRI NET MBH	AFUE	Fuel	Pump	Tankless Coil	Firing Rate GPH	Tankless GPM	Shp. Wgt. lbs	Trade Price
3KWC0.80	KWC308031200107	112	98	85	86.0%	OIL	LESS	LESS	0.80	N/A	470	\$2,422
4KWC1.00	KWC410031200107	140	122	106	86.2%	OIL	LESS	LESS	1.00	N/A	545	\$2,600
4KWC1.25	KWC412531200107	175	152	132	86.0%	OIL	LESS	LESS	1.25	N/A	545	\$2,600
5KWC1.55	KWC515531200107	217	189	164	86.0%	OIL	LESS	LESS	1.55	N/A	630	\$3,493
3KWC0.80	KWC308031210107	112	98	85	86.0%	OIL	TACO	LESS	0.80	N/A	470	\$2,507
4KWC1.00	KWC410031210107	140	122	106	86.2%	OIL	TACO	LESS	1.00	N/A	545	\$2,685
4KWC1.25	KWC412531210107	175	152	132	86.0%	OIL	TACO	LESS	1.25	N/A	545	\$2,685
5KWC1.55	KWC515531210107	217	189	164	86.0%	OIL	TACO	LESS	1.55	N/A	630	\$3,575
3KWC0.80	KWC308031220107	112	98	85	86.0%	OIL	GRUNDFOS	LESS	0.80	N/A	470	\$2,507
4KWC1.00	KWC410031220107	140	122	106	86.2%	OIL	GRUNDFOS	LESS	1.00	N/A	545	\$2,685
4KWC1.25	KWC412531220107	175	152	132	86.0%	OIL	GRUNDFOS	LESS	1.25	N/A	545	\$2,685
5KWC1.55	KWC515531220107	217	189	164	86.0%	OIL	GRUNDFOS	LESS	1.55	N/A	630	\$3,575
3KWC0.80T	KWC308032200107	112	98	85	86.0%	OIL	LESS	COIL	0.80	3.05	470	\$2,747
4KWC1.00T	KWC410032200107	140	122	106	86.2%	OIL	LESS	COIL	1.00	3.25	545	\$2,925
4KWC1.25T	KWC412532200107	175	152	132	86.0%	OIL	LESS	COIL	1.25	3.50	545	\$2,925
5KWC1.55T	KWC515532200107	217	189	164	86.0%	OIL	LESS	COIL	1.55	3.80	630	\$3,900
3KWC0.80T	KWC308032210107	112	98	85	86.0%	OIL	TACO	COIL	0.80	3.05	470	\$2,832
4KWC1.00T	KWC410032210107	140	122	106	86.2%	OIL	TACO	COIL	1.00	3.25	545	\$3,010
4KWC1.25T	KWC412532210107	175	152	132	86.0%	OIL	TACO	COIL	1.25	3.50	545	\$3,010
5KWC1.55T	KWC515532210107	217	189	164	86.0%	OIL	TACO	COIL	1.55	3.80	630	\$3,980
3KWC0.80T	KWC308032220107	112	98	85	86.0%	OIL	GRUNDFOS	COIL	0.80	3.05	470	\$2,832
4KWC1.00T	KWC410032220107	140	122	106	86.2%	OIL	GRUNDFOS	COIL	1.00	3.25	545	\$3,010
4KWC1.25T	KWC412532220107	175	152	132	86.0%	OIL	GRUNDFOS	COIL	1.25	3.50	545	\$3,010
5KWC1.55T	KWC515532220107	217	189	164	86.0%	OIL	GRUNDFOS	COIL	1.55	3.80	630	\$3,980
KWC (Use Parts Multiplier for All of the Following)												
Model	Item Number	Description										Trade Price
KWC	550002647	4 SECTION RE-RATE KIT 4100/4125										\$26
KWC	14624002	FILL-TROL FOR WATER BOILERS 150 MBH OR LESS										\$321
KWC	14624003	FILL-TROL FOR WATER BOILERS OVER 150 MBH										\$445

SBO Cast-Iron Steam Boilers

- MBH Input 119 - 210 (CH)
- Up to 85.6% AFUE
- Dependable Cast Iron Heat Exchanger
- Honeywell Operating Control
- Burner swing door for easy serviceability
- Multiple Firing Rates
- Chimney Venting
- Optional tankless domestic hot water (DHW) coil



General Information (See IOM for Complete Instructions)				
Model	SBO-3085	SBO-3105	SBO-4125	SBO-4150
Return/Supply Tappings	1 1/4" Return NPT, 2" Supply NPT			
Oil	3/8" O.D. Copper (runs 50' or less, 1/2" O.D. Copper (runs over 50')			
Electrical	120 Volts AC, 60 hertz, 1 phase, less than 12 amps (15 amp circuit recommended)			
Water Content (Gallons)	12	12	14.87	14.87
Dimensions	A-Height	35"	35"	35"
	B-Width	22 1/8"	22 1/8"	22 1/8"
	C-Depth	15 3/4"	15 3/4"	19 3/4"
Weight	570 lbs.	570 lbs.	685 lbs.	685 lbs.

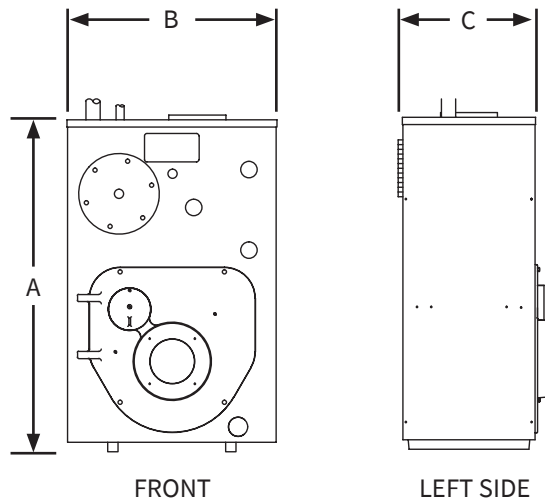

SBO - Cast Iron Steam Oil Boilers Less Burner											
Model	Item Number	Type	Input MBH	Htg. Cap. MBH	AHRI Net MBH	AHRI Net Sq. Ft. Steam	AFUE	Burner	Firing Rate GPH	Shp. Wgt. lbs	Trade Price
SBO-3105	SBO310521700107	LESS	147	127	95	396	85.0%	LESS	1.05	688	\$2,263
SBO-4150	SBO415021700107	LESS	210	180	135	563	85.0%	LESS	1.50	901	\$3,183

SBO (Use Equipment Multiplier for All of the Following)			
Model	Item Number	Description	Trade Price
SBO	550004158P	TANKLESS COIL WITH CONTROL	\$399
SBO-3105	550004153P	SBO-3105 BECKETT BURNER IN A BOX KIT	\$670
SBO-4150	550004154P	SBO-4150 BECKETT BURNER IN A BOX KIT	\$670

Please Note: Oil Fired Steam Boilers are sold less burner. Please add burner in a box kit to your order.

Tankless Coil Kits are sold separately.

SBO (Use Parts Multiplier for All of the Following)			
Model	Item Number	Description	Trade Price
SBO	550004155	3085/3105 BECKETT RERATE KIT	\$126
SBO	550004156	4125/4150 BECKETT RERATE KIT	\$126

H2O GL Single Coil Glass Lined Indirect Water Heaters

- 31 - 106 Gallon Capacities
- Easy to Install
- Low Pressure Drop
- Magnesium Anode Rod Corrosion Protection
- Enameled Coated Steel Tank and Coil
- Minimal Standby Losses
- Flexible Scratch Resistant Jacket
- Aquastat Sensor Well
- Temperature Pressure Relief Valve



(H2O40GL Model Shown)

General Information (See IOM for Complete Instructions)					
Maximum Working Pressure: 150 psi for all Capacities					
Model	Piping Connections NPT		Dimensions		
	Domestic Water In/Out	Boiler Water In/Out	Diameter	Height	Weight
H2O 30 GL	1"	1"	24"	33"	119 lbs
H2O 40 GL	1"	1"	24"	45"	180 lbs
H2O 50 GL	1"	1"	24"	51"	200 lbs
H2O 80 GL	1"	1"	30"	48"	243 lbs
H2O 105 GL	1"	1"	30"	62"	393 lbs

H2O GL - Single Coil Glass Lined Indirect Water Heaters

Model	Item Number	Storage Capacity gal	Type	Max. First Hour Rating gal/hr @ 115° F	Continuous Rating gal/hr @ 115° F	Boiler Output Req. BTU/hr	Shp. Wgt. lbs	Trade Price
H2O 30 GL	H2OIG30PN	31	GLASS LINED	155	124	100,000	119	\$1,032
H2O 40 GL	H2OIG40PN	42	GLASS LINED	256	220	120,000	180	\$1,053
H2O 50 GL	H2OIG50PN	53	GLASS LINED	310	268	140,000	200	\$1,199
H2O 80 GL	H2OIG80PN	79	GLASS LINED	346	281	180,000	243	\$1,663
H2O 105 GL	H2OIG105PN	106	GLASS LINED	440	345	220,000	393	\$2,601

H2O GL (Use Parts Multiplier for All of the Following)

Model	Item Number	Description	Trade Price
30-105 GAL.	240010926	T & P VALVE 3/4, 100XL-8	\$47
30-105 GAL.	AQ-020.01	AQUASTAT WELL	\$32
30-105 GAL.	240009521	AQUASTAT L4080B1352	\$130
30-50 GAL.	240012211	PLASTIC TOP CAP	\$26
80-105 GAL.	240012239	PLASTIC TOP CAP	\$36
40-105 GAL.	240012212	PLASTIC FRONT CAP	\$8
30 GAL.	550003640	ANODE KIT MAGNESIUM (INCLUDES ANODE, GASKET & BUSHING)	\$34
40-50 GAL.	550003505	ANODE KIT MAGNESIUM (INCLUDES ANODE, GASKET & BUSHING)	\$34
80-105 GAL.	550003527	ANODE KIT MAGNESIUM (INCLUDES ANODE, GASKET & BUSHING)	\$66
30 GAL.	550003693	ANODE KIT ALUMINUM (INCLUDES ANODE, GASKET & BUSHING)	\$33
40-50 GAL.	550003694	ANODE KIT ALUMINUM (INCLUDES ANODE, GASKET & BUSHING)	\$34
80-105 GAL.	550003695	ANODE KIT ALUMINUM (INCLUDES ANODE, GASKET & BUSHING)	\$66
30-50 GAL.	240012250	FLANGE CAP	\$36
80-105 GAL.	240012251	FLANGE CAP	\$13
30-50 GAL.	240012210	FLANGE GASKET	\$2
80-105 GAL.	240012238	FLANGE GASKET	\$4
40-50 GAL.	550003510	HARDWARE KIT (INCLUDES BOLTS & NUTS FOR FLANGE CAP)	\$4
80-105 GAL.	550003525	HARDWARE KIT (INCLUDES BOLTS & NUTS FOR FLANGE CAP)	\$4
H2O 30 GL	240012474	OUTSIDE TANK COVER	\$96
H2O 40 GL	240012329	OUTSIDE TANK COVER	\$97
H2O 50 GL	240012330	OUTSIDE TANK COVER	\$104
H2O 80 GL	240012331	OUTSIDE TANK COVER	\$113
H2O 105 GL	240012332	OUTSIDE TANK COVER	\$127
30-50 GAL.	240012483	TEMPERATURE GAUGE	\$14
80-105 GAL.	240012484	TEMPERATURE GAUGE	\$21

TERMS & CONDITIONS OF SALE - GENERAL TERMS

PRICES & SPECIFICATIONS: All pricing and specifications subject to change without notice. The prices herein supersede all prior quotations.

ORDERS: Orders will be accepted based on prices in effect at the time the order is received. No order or contract will become an obligation on our part until accepted by the General Sales Department. ECR International shall not be liable for any delay or failure in the delivery or shipment of goods due to any cause or causes beyond its control.

TAXES: Add to the prices and terms quoted any manufacturers' or sales tax payable on the transaction under any effective statute.

SHIPMENTS

TRUCKLOADS: \$40,000 Net Order Value - Freight Prepaid. Indirect Water Heaters and Commercial Boiler lines can be added to any residential order for freight purposes. Authorized Distributors can combine Argo, Airco, Dunkirk, EMI, Olsen, Pennco, Utica Boilers and Utica Heating on one purchase order to earn free freight.

Stop off charges of \$150 will apply to stop off locations within 100 miles of final destination. Please call for pricing for stop off special handling for a location further than 100 miles or for special handling pricing for services such as lift gate, unloading assistance, etc.

LESS THAN TRUCKLOAD SHIPMENT: F.O.B. ECR INTERNATIONAL - FACTORY OR WAREHOUSE

SALES ORDER INFORMATION CHECK LIST

The following information must be included on equipment or parts orders to insure proper shipment & invoicing:

- | | |
|--|--|
| 1) Purchase Order Number | 7) Pricing |
| 2) Bill to Address | 8) Product Description (Model, Size, etc.) |
| 3) Ship to Address | 9) Fuel Type (Oil, Natural Gas, Propane) |
| 4) Method of Shipment (trailer load, UPS) | 10) Electrical (Operating Voltage, Cycles, Phases, etc.) |
| 5) Requested Ship Date | 11) Non-Standard Equipment (Indicate "Optional" when substituted for standard equipment at extra cost listed. Indicate added to standard equipment.) |
| 6) Special Instructions ("Carrier to call...") | 12) Kits or Parts (Orders for kits or parts must indicate equipment size and series.) |

Send orders to:

E-mail: ecrorderentry@ecrinternational.com

Fax: (315) 724-9319

Please note the following Remit to Address:

ECR International, Inc.

P.O. Box 8000 Department 039

Buffalo, NY 14267

U.S. DISTRIBUTOR - RETURN MATERIAL POLICY

Prior Approval Required - All returns for exchange, credit, repair service or warranty claim must be approved by ECR International and require an RMA number prior to return of the material. A request must be completed via the online web portal. Please log on to www.ecrcustomerportal.com to complete your request for return. If you do not already have access to the customer web portal, please contact ECR International Customer Service at 1-800-325-5479 to be set-up.

Eligibility – An RMA Request must be received within 60 days from the date of invoice for returns of New & Unused product in original packaging. A restocking fee of 15% will be charged for all new and unused returns that are approved for return. Special Order Products (items not offered as standard in ECR International trade price book) are not eligible for return as new and unused product. Request for Warranty Returns must be made within the period covered by the warranty and must fall under the terms and conditions specified in the warranty.

Repair Service - Request for repair or rework of product damaged by customer is classified as Repair Service. Repair Service is billed at \$75.00 per hour for labor and net price for parts used in repair/rework. ECR International's Return Material (RM) department will evaluate the items returned for repair service. The customer will receive an estimate for the dollar amount, determined by ECR International's RM department, required to complete the repairs requested. A Purchase Order (PO) from the customer for that amount will be required before any work is performed.

RMA Expiration Parts - Once the RMA number is issued, the product must be returned within 60 days of the RMA date, or the RMA will be canceled. Products approved for return that are received after 60 days from the RMA date will not be accepted.

Shipping & Packaging - All returns must have a valid RMA number clearly displayed on the exterior of the package or the package will not be accepted. All returns of new and unused product must be in the original packaging. All returns must be shipped prepaid by the customer unless otherwise directed by ECR as indicated on the RMA Verification. Ship all approved return material to the facility indicated on the approved RMA Request by the date indicated.

Replacement Product - If replacement product is desired it must be indicated on the RMA Request. A PO# is required for the replacement shipment and must be indicated on the RMA Request. All replacement products will be invoiced at the time of shipment. ECR will pay the ground freight for all warranty replacements.

Application of Credit - Credit for returned product will be applied to the customer's account (less restocking fees for New and Unused returns) only after confirmation of receipt by ECR and inspection of the product. Issuance of a credit for a partial return of product does not relieve the customer from the obligation to remit payment for the merchandise not returned in accordance with the payment terms referenced on the customer's invoice(s). Customer will have the option to have any product that is denied for credit returned at their expense.

Returning Installed Finished Goods (Complete boilers, furnaces, A/C units etc.)

- Equipment that is already installed should be repaired not replaced. Exceptions: leaking cast iron boilers in their first year or leaking water tanks. Leaking drain valves on water tanks are replaceable, make sure the leak is not on the valve. Tanks returned with the only leak being on the valve will be denied.
- Cast iron blocks (not complete boilers) older than one year and Indirect tanks that are leaking do not require prior approval. Simply type "Leaking" into the Authorization field and it will be accepted. Complete Cast iron boilers within their first year will still require prior authorization for full boiler replacement.
- Water leaks on copper and condensing boilers are repairable and will require prior authorization for any reason for removal.
- To guarantee credit, if a situation arises where equipment does need to be replaced, **prior authorization** from ECR is required. This will ensure that ECR has visibility to the problem and has had an opportunity to correct it prior to removal. *All equipment considered for removal should first be brought to the attention of Technical Support at 1-800-253-7900.*
- If approved, an authorization number will be given that will need to be entered in the RMA on the Customer Portal.
- For equipment that is removed from service without prior authorization by ECR, contact Customer Service. They will evaluate the circumstance and can issue a conditional RMA. The equipment will be tested in our lab to determine if removal was warranted and if credit will be given.

RMA Expiration Equipment - Once the RMA number is issued, the product must be returned within 30 days of the RMA date, or the RMA will be canceled. Products approved for return that are received after 30 days from the RMA date will not be accepted.

This page is intentionally left blank.

This page is intentionally left blank.



2201 Dwyer Avenue, Utica, NY 13501
Tel. 800 325 5479
www.ecrinternational.com

All specifications subject to change without notice.
©2021 ECR International, Inc.
PN 240004966 REV. H [01/01/2021]