



SSC 
STAINLESS STEEL CONDENSING

Utica SSC Training Seminar
Instructor:





Ratings & Capacities

Capacities BTUH	50,000	75,000	100,000	150,000	200,000	299,000
Modulation with 5 to 1 turndown	50,000 ----- 10,000	75,000 ----- 15,000	100,000 ----- 20,000	150,000 ----- 30,000	200,000 ----- 40,000	299,000 ----- 60,000
Nat or LP	LP conversion kits are shipped with every boiler					
AFUE	95	95	95	95	94	94
Water Connections	1-1/4"	1-1/4"	1-1/4"	1-1/4"	1-1/4"	1-1/4"





Model Size	50,000 75,000 100,000	150,000 200,000	299,000
Width (A)	20"	23"	23"
Height (B)	30"	40"	40"
Depth (C)	14"	16"	18.3"
Boiler Weights	<u>91 lb</u>	<u>157 lb</u>	<u>195 lb</u>

- **Vertical Stainless Steel Coil Heat Exchanger**
- **Probe-type low water cut-off**
- **Specialized flue collector designs**
- **Argus vision control**
- **Built-in Primary/Secondary Piping**

- Factory installed.
- Low pressure drop (less than ½ psi) across the boiler's supply and return connections.
- Hydraulically Separates boiler from the system.
- A ball valve is located between the closely spaced tees.

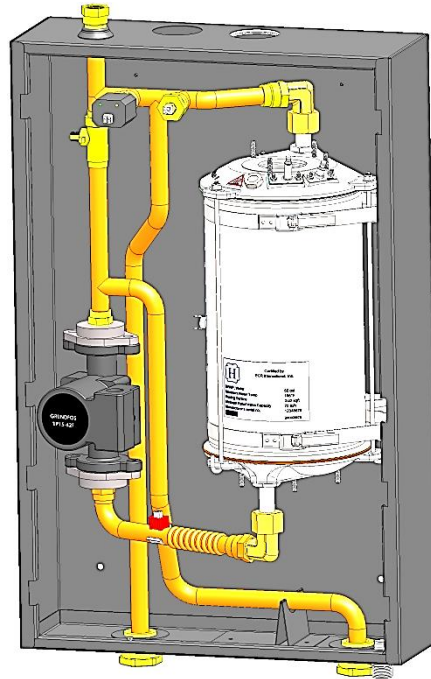

Benefits

Saves the installer material and labor.

No need to purchase a costly high head pump. Easy to connect to existing systems without extensive re-piping.

Ensures proper flow through the boiler's heat exchanger regardless of how many system zones are open or closed.

Increases the boiler's piping options when the existing system already has a set of closely spaced tees or when installing a new multiple boiler system.

- Primary Secondary can be either internal to boiler or external to already existing closely spaced tee's!
- Saves both time and money on install
- **Note: System requires at least one secondary circulator.**

Ball Valve

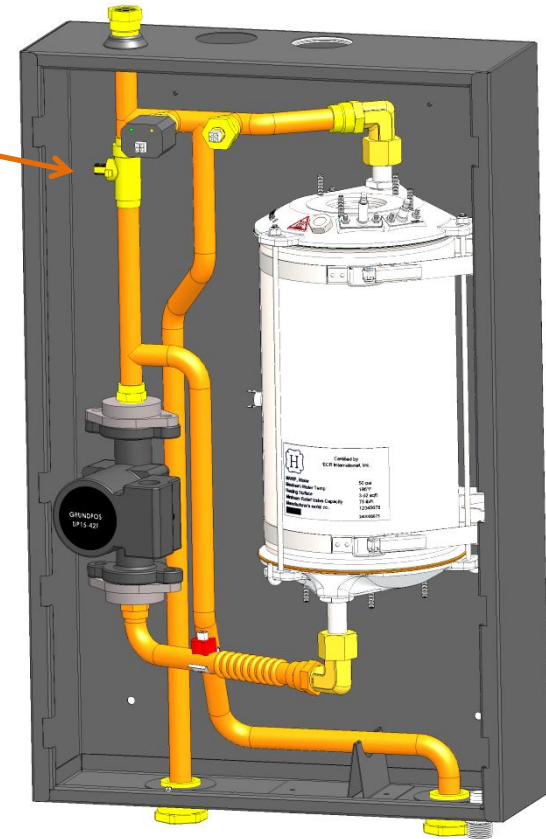

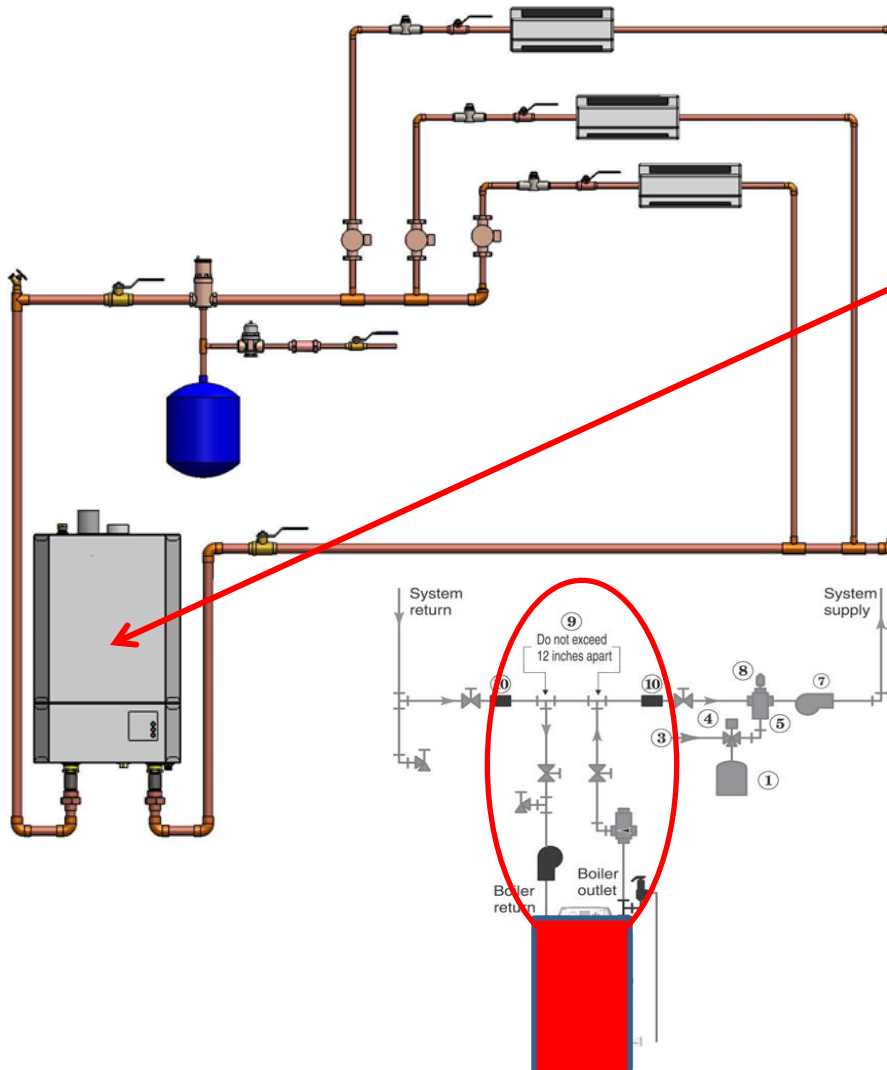

Primary/Secondary Piping and Pump

Factory installed inside the boiler.

The internal pump provides the correct amount of water flow through the heat exchanger.

The pressure drop across the boiler's supply and return line is negligible - the boiler is not adding resistance to the system piping.

SSC Contractor Challenge

- Targeted Contractors who sell competitors MODCONs.
- When we compare price to price we are often equal, sometimes higher.
- When the filled out the Scorecard we found to be from \$343 to \$1700 LESS!!



Utica SSC Contractor Challenge Scorecard

Date: 10-12-12

Company Name: [Redacted] Score Keeper Name: [Redacted]

Street Address: [Redacted] Utica Representative: [Redacted]

City, State, Zip: [Redacted] ECR RSM: [Redacted]

Phone: [Redacted] Distributor: [Redacted]

Email: [Redacted]

Competitor Scorecard

Competitive Condensing Boiler		Manufacturer and Model				
		Weil Mclain Ultra 230				
Item	Material Cost	Labor Hours	Labor Cost per Hour	Total Labor Cost	Description	Total Cost (Material + Labor)
Cost of Competitive Boiler	4221.87	17	150.	2550.		6,771.87
Primary/ Secondary Piping	285.40	2	150	300	Cost to purchase all piping, fittings, valves and materials to construct the P/S loop. Include the time, number of technicians and fully burdened labor rate to install.	585.40
Primary Pump (if not included)	278.48	1	150	150	Cost of primary pump and labor to install	428.48
Code Compliant LWCO (if applicable)					Cost of probe type LWCO	-
Electrician/Labor to install and wire LWCO					Cost of labor or sub-contracted electrician to wire and install LWCO	-
Wall Bracket						-
Productivity Rating					Total labor time required for installation start to finish (number of technicians x hours to complete)	20
Total Cost:						7,785.75

\$1575.82

SSC Scorecard

SSC						
Item	Material Cost	Labor Hours	Labor Cost per Hour	Total Labor Cost	Description	Total Cost (Material + Labor)
SSC Cost	3809.93	16	150	2,400.		6,209.93
Primary/ Secondary Piping		0			Cost to purchase all piping, fittings, valves and materials to construct the P/S loop. Include the time, number of technicians and fully burdened labor rate to install.	-
Primary Pump (if not included)					Cost of primary pump and labor to install	-
Code Compliant LWCO (if applicable)					Cost of probe type LWCO	-
Electrician/Labor to install and wire LWCO					Cost of labor or sub-contracted electrician to wire and install LWCO	-
Wall Bracket						-
Productivity Rating					Total labor time required for installation start to finish (number of technicians x hours to complete)	16
Total Cost:						6,209.93



The SSC Contractor Challenge Scorecard



Date:	12/4/2012	Score Keeper Name:	[REDACTED]
Company Name:	[REDACTED]	Utica Representative:	[REDACTED]
Street Address:	[REDACTED]	ECR RSM	[REDACTED]
City, State, Zip:	[REDACTED]	Distributor:	[REDACTED]
Phone:	[REDACTED]		
Email:	[REDACTED]		

COMPETITOR SCORECARD

Competitive Condensing Boiler Manufacturer and Model						
Item Cost of Competitive Boiler	Material Cost	Labor Hours	Labor Cost per Hour \$85	Total Labor Cost	Description	Total Cost (Material + Labor)
					Weil Mc Cain Ultra	\$4300
Primary/ Secondary Piping	\$165	4	\$35		Cost to purchase all piping, fittings, valves and materials to construct the P/S loop. Include the time, number of technicians and fully burdened labor rate to install.	\$700
Primary Pump (if not included)	\$300				Cost of primary pump and labor to install	\$300
Code Compliant LWCO (if applicable)	φ				Cost of probe type LWCO	φ
Electrician/Labor to install and wire LWCO	φ				Cost of labor or sub-contracted electrician to wire and install LWCO	φ
Wall Bracket	φ					
Productivity Rating					Total labor time required for installation start to finish (number of technicians x hours to complete)	\$1200
Total Cost:						\$6500

\$605.00

SSC SCORECARD

SSC						
Item SSC Cost	Material Cost	Labor Hours	Labor Cost per Hour	Total Labor Cost	Description	Total Cost (Material + Labor)
					UPSSC A200	\$4395
Primary/ Secondary Piping					Cost to purchase all piping, fittings, valves and materials to construct the P/S loop. Include the time, number of technicians and fully burdened labor rate to install.	φ
Primary Pump (if not included)					Cost of primary pump and labor to install	φ
Code Compliant LWCO (if applicable)					Cost of probe type LWCO	φ
Electrician/Labor to install and wire LWCO					Cost of labor or sub-contracted electrician to wire and install LWCO	φ
Wall Bracket						φ
Productivity Rating					Total labor time required for installation start to finish (number of technicians x hours to complete)	\$1500
Total Cost:						\$5895



The SSC Contractor Challenge Scorecard



Date:	12/28/2012	Score Keeper Name:	
Company Name:		Utica Representative:	
Street Address:		ECR RSM:	
City, State, Zip:		Distributor:	
Phone:			
Email:			

COMPETITOR SCORECARD

Competitive Condensing Boiler Manufacturer and Model						
Item	Material Cost	Labor Hours	Labor Cost per Hour	Total Labor Cost	Description	Total Cost (Material + Labor)
Item Cost of Competitive Boiler			\$80		Triangle Tube Prestige	\$3500
Primary/ Secondary Piping	\$240	2	\$200		Cost to purchase all piping, fittings, valves and materials to construct the P/S loop. Include the time, number of technicians and fully burdened labor rate to install.	\$400
Primary Pump (if not included)	\$25	.5	\$300		Cost of primary pump and labor to install	\$145
Code Compliant LWCO (if applicable)	\$60	.5	\$200		Cost of probe type LWCO	\$100
Electrician/Labor to install and wire LWCO					Cost of labor or sub-contracted electrician to wire and install LWCO	φ
Wall Bracket						φ
Productivity Rating		12	\$80		Total labor time required for installation start to finish (number of technicians x hours to complete)	\$960
Total Cost:						\$105

\$343.00

SSC SCORECARD

SSC						
Item	Material Cost	Labor Hours	Labor Cost per Hour	Total Labor Cost	Description	Total Cost (Material + Labor)
SSC Cost			\$80		SSC 200	\$3842
Primary/ Secondary Piping	\$80	.5	\$200		Cost to purchase all piping, fittings, valves and materials to construct the P/S loop. Include the time, number of technicians and fully burdened labor rate to install.	\$120
Primary Pump (if not included)					Cost of primary pump and labor to install	φ
Code Compliant LWCO (if applicable)					Cost of probe type LWCO	φ
Electrician/Labor to install and wire LWCO					Cost of labor or sub-contracted electrician to wire and install LWCO	φ
Wall Bracket						φ
Productivity Rating		10	\$80		Total labor time required for installation start to finish (number of technicians x hours to complete)	\$800
Total Cost:						\$4762



Selling Installed Valued – Contractor Testimonial

“We went from two men, two days to two men one day!” “We are still quoting and getting jobs with 2 men/2 days but are much more profitable, and competitive with the SSC and H2O”

- Vertical Helix Coil – Self Cleaning



- Stainless Steel Coil 316L with 444 fins that are laser welded to the coil.
- ASME “H” stamp with 150 MAWP
- Exclusive to ECR. Developed in our research facility located in Utica, NY

Benefits

Waterways are wide and smooth with a helix coil that expands and contracts to inhibit hard water scaling. The vertical design coil prevents debris from settling in the heat exchanger. Condensate flowing over the fins continually “washes” the combustion side

The stainless steel is resistant to the effects of acidic condensate. The laser welding process ensures the highest level of heat transfer and efficiency

H Stamped, ASME heat exchanger designed, assembled and independently audited in our Utica NY facility.

- 316L/444 Stainless Steel Coil
- Wide open design
- No high head pump required
- Self cleaning action
- We live up to our claim

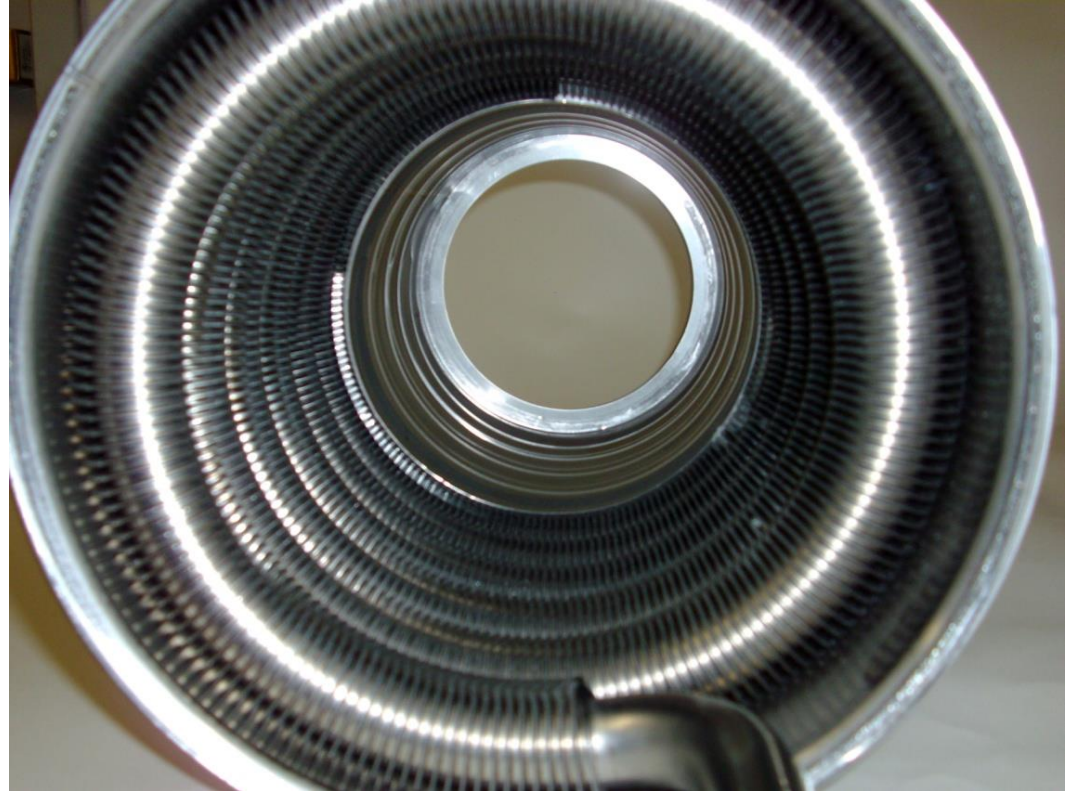



Stainless Steel Coil Heat Exchanger 299 Series





Stainless Steel Coil Heat Exchanger

SSC Heat Exchanger Construction

316L stainless steel tubing has 444 fins laser welded onto the tubing. 444 fins are used due to their high heat transfer and high corrosion resistance in the combustion area.

Tubing Diameter

The larger diameter tubing and round shape optimize water flow through the heat exchanger.

Positioning / Self Cleaning

The vertical positioning of the coil heat exchanger and open fin spacing allows the heat exchanger to drain off any combustion particles. The natural flexing of the coil during operation reduces scale buildup

Self cleaning – both water and flue gas sides



SSC Coil



SSC round shape with a larger diameter coil for better water flow and reduced scaling



Vertically positioned to drain away any debris and scale - self cleaning. Open flueways between the coils.

Heat Exchanger Comparisons



SSC Coil

Water Tube – Single piece coil

Self Cleaning

Flue Gas Side – **Yes**

Water Side – **Yes** - water flow velocity is maintained preventing debris from settling. The natural flexing of the coil (during operation) reduces scale buildup

15 year HX warranty

5:1 turndown

95% AFUE

94% AFUE (200/299 sizes)

Vertically Positioned - yes
Self Cleaning – (see below)
Stainless Construction – yes

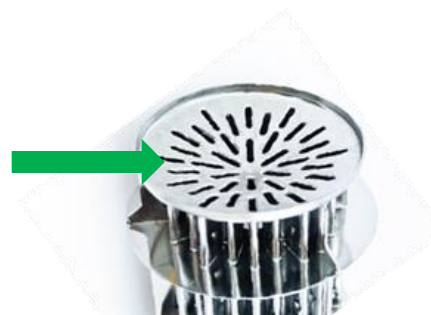

Competition



Fire Tube – Multiple tubes with welded connections potential stress and leak points

Self Cleaning

Flue Gas Side – **Yes**

Water Side – Water flow velocity is reduced allowing debris to settle inside the heat exchanger

10 year HX warranty

3.7:1 or 5:1 turndown – depending on manufacture

95% AFUE

- Worgas™ designed gas burner
- Natural / propane
- Easy removal for field inspection
- Easy removal for maintenance to heat exchanger

Note: Burner is keyed to heat exchanger. Line up notch in heat exchanger casting.



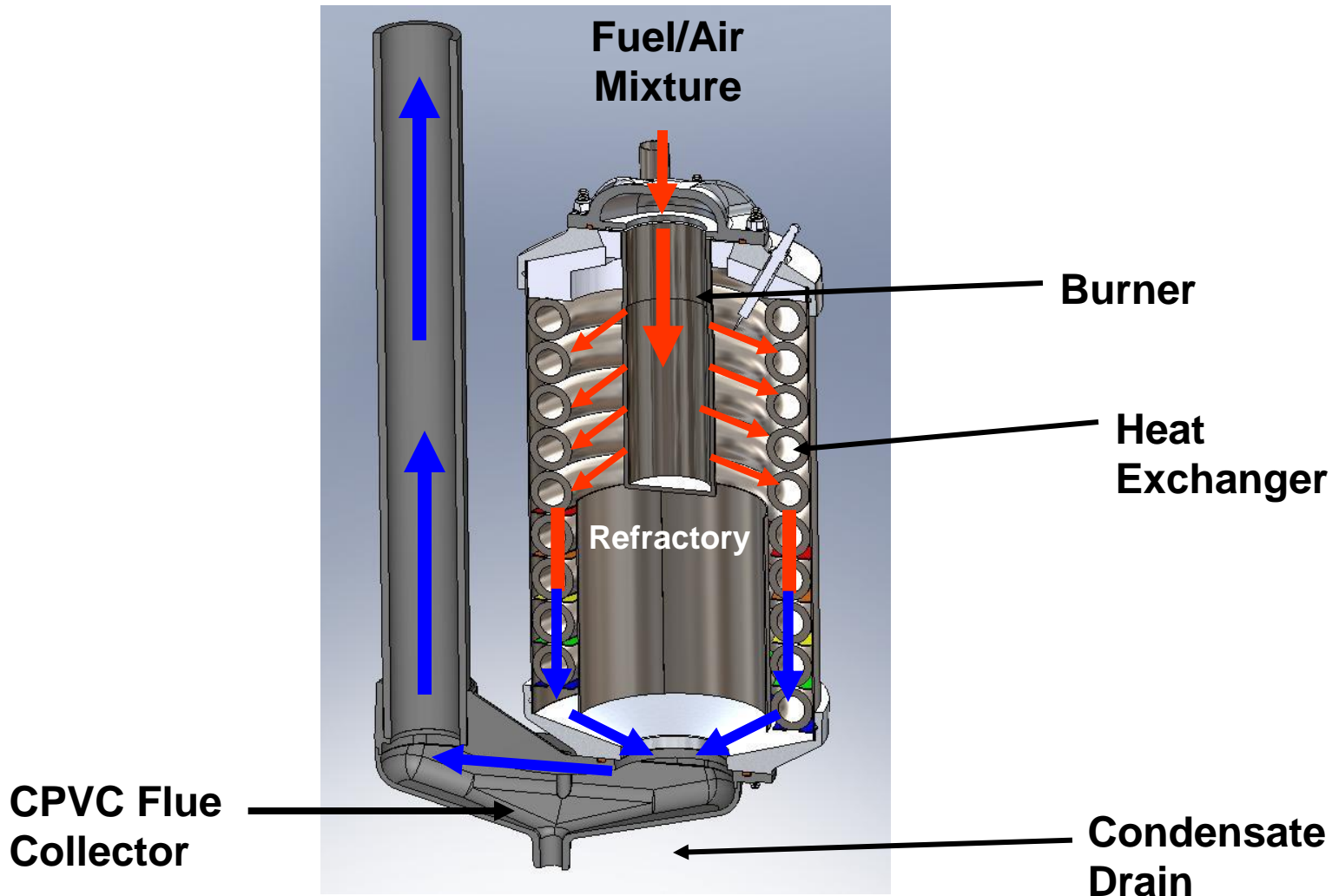

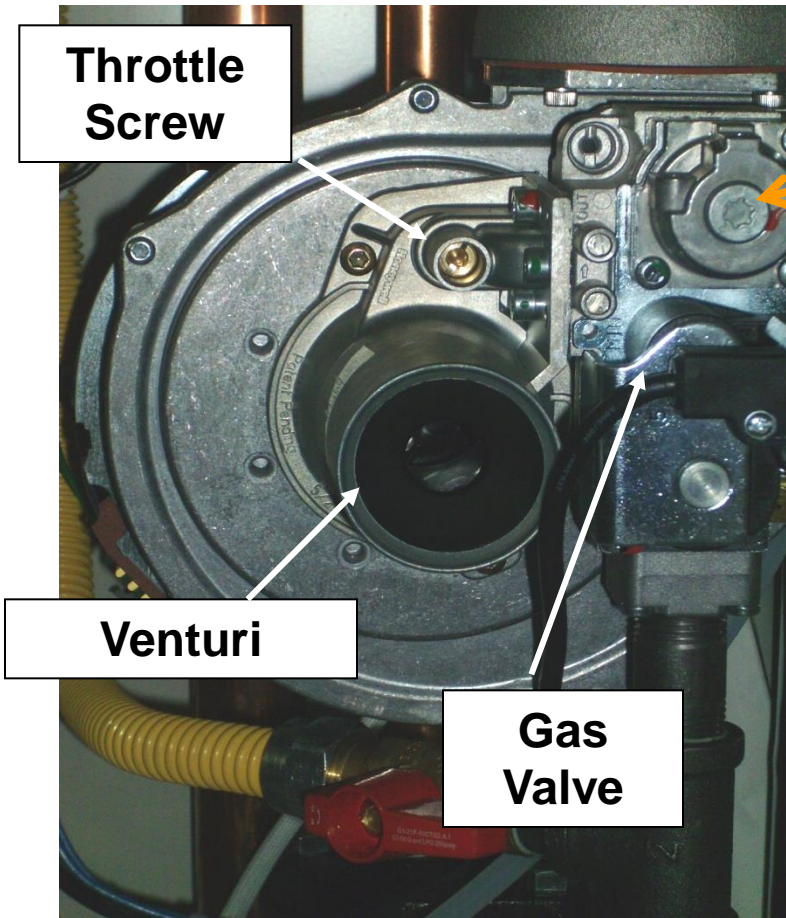

Don't touch offset screw
Will void valve's calibration

- 120 volt gas valve system
- Venturi system takes air from within the sealed cabinet
- Adjust throttle screw for proper gas / air CO² setting

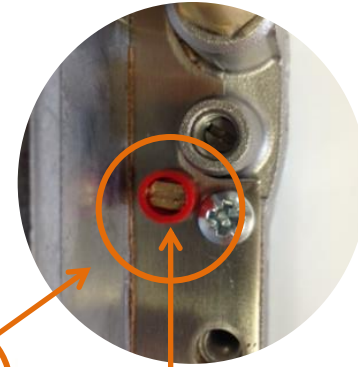
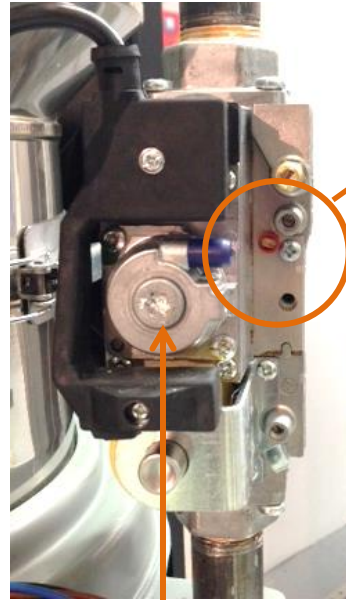

Throttle Screw (red)

Don't touch offset screw – will void gas valve calibration.





Low Water Cutoff

- Protects the boiler.
- Factory installed.
- Probe style.
- Test button feature with indicator lights.

Benefits

Prevents boiler operation without the proper water level.

Saves the installer material and labor. Most States now require a boiler to have a low water cutoff.

Reliably operates off of the water level in the boiler and not a pressure or flow sensing device. This is not a surface mounted sensor.

Easy to test and verify the LWCO is operating properly.

Specialized Flue Collector

Schedule 40 CPVC (Changing to Polypropylene)

Exceptional resistance to the effects of acidic condensate.

Will not corrode over the life of the boiler.

Saves the installer material and labor.

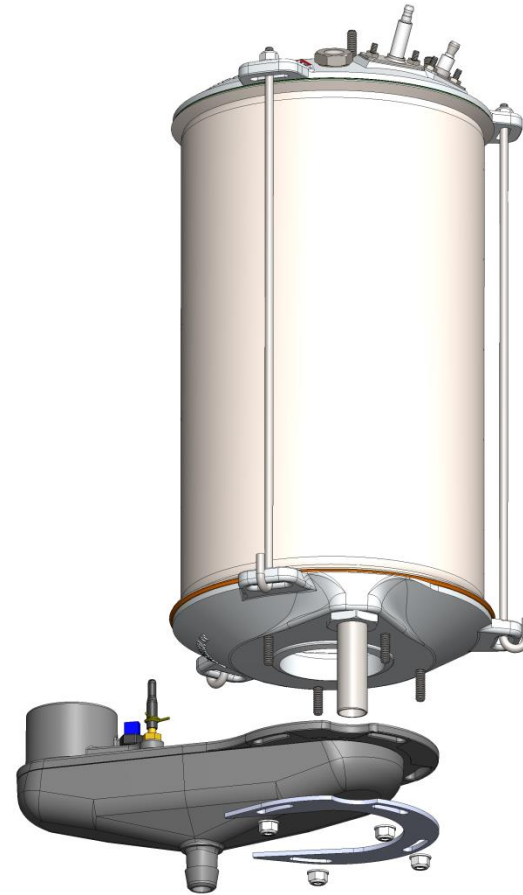

Benefits

Polypropylene – High temperature rating.

Exceptional resistance to the effects of acidic condensate.

Will not corrode over the life of the boiler.

Flue Gas sample port built in.



- Drain is $\frac{3}{4}$ " PVC NPT.
- Internal trap built into boiler drain.
- Fill trap with water prior to start of boiler.
- Contractor is required to run a drain off boiler.

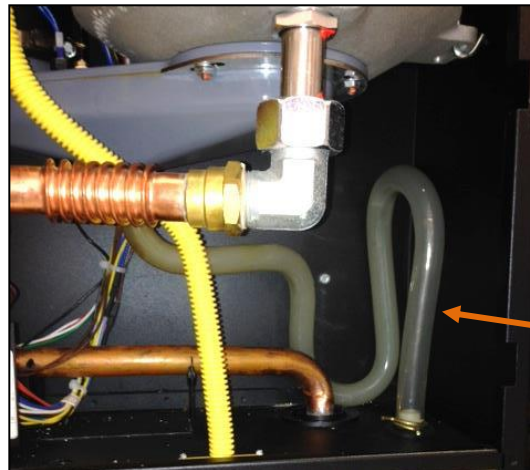

Built-in
Trap



ARGUS™ Control
EASY TO PROGRAM
EASY TO UNDERSTAND

Same Control on 50-299 models!



Boiler Clearances		
Dimension	Combustible Materials (1)	Service (1) (2)
Model	050 / 075 / 100 / 150 / 200 / 299	050 / 075 / 100 / 150 / 200 / 299
Top	0" (0 cm)	14" (36 cm)
Left Side	0" (0 cm)	0" (0 cm)
Right Side	0" (0 cm)	0" (0 cm)
Front	0" (0 cm)	6" (16 cm)
Back	0" (0 cm)	0" (0 cm)
Bottom	0" (0 cm)	12" (32 cm)
Combustion Air/Vent Piping	0" (0 cm)	6" (16 cm)
Hot Water Piping	1/2" (1.3 cm)	6" (16 cm)
(1) Required distances measured from boiler.		
(2) Service, proper operation clearance recommendation.		



- Access to outdoors to meet minimum and maximum pipe lengths
- Disposal of condensate
- Drainage of water or anti-freeze during service or from safety relief valve piping
- Access to system water, gas piping and electrical service
- Ambient room location above 32°F
- Approved for installation in a closet
- Protect boiler from any external water or moisture that could damage the electrical or combustion controls

Rear of Boiler

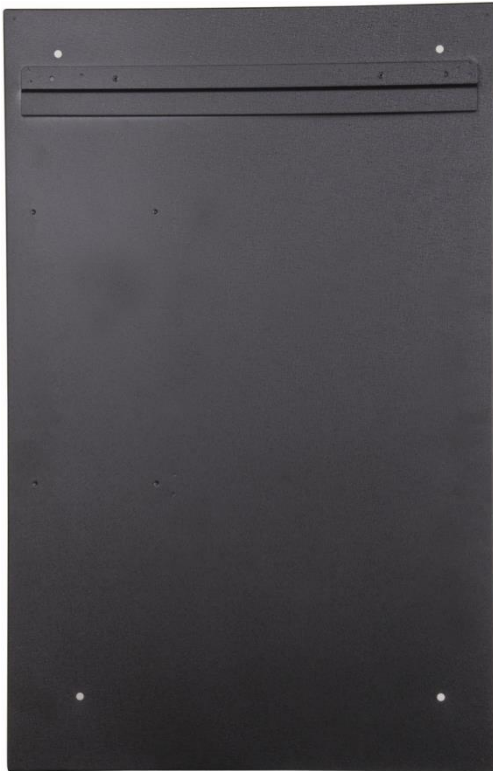

Wall Mounting Bracket & Hardware

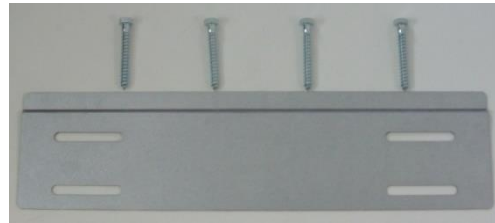

NEW! Optional Floor Stand

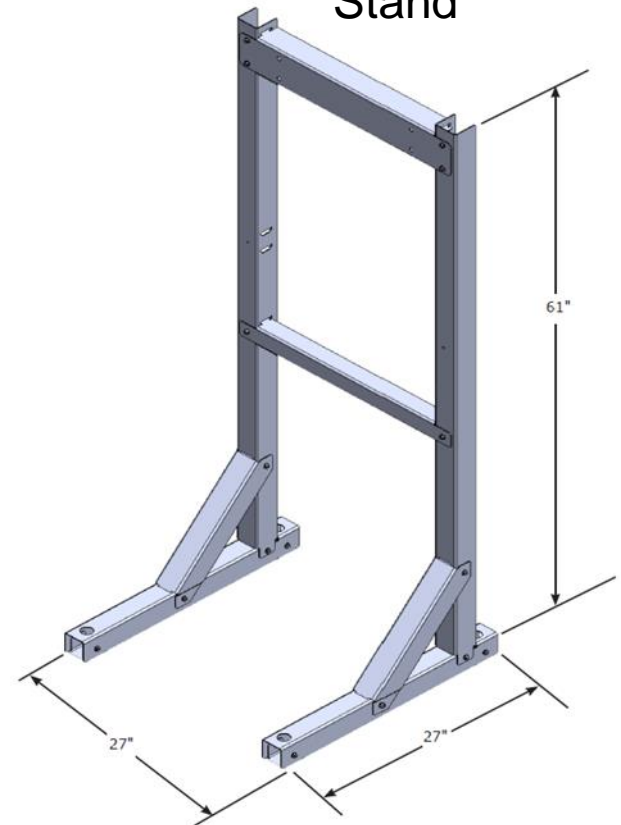

Wall Mount Bracket and Hardware Included

Note: For Multiple Boiler Applications - Boilers can be placed side by side or back to back

Floor Stand Features Include:

- Powder Coated Black Paint with a textured finish to match the boiler back panel. The paint process provides a durable rust resistant finish.
- One size floor stand fits the entire SSC condensing family from 50 through 299 mbh.
- The stand is shipped in a knockdown configuration for ease of handling and transport. The stand can be quickly assembled at the jobsite in just a few minutes.



- Bottom Supply and Return - 1-1/4" NPT
- Fuel Inlet – 1/2" NPT 50-75-100
3/4" 150 – 200 - 299
- Condensate Drain – 3/4" NPT
- Combustion Air & Vent – 2" or 3"
- 3/4" NPT Stub out on top for field installation of Safety Relief & Air Vent (included with Boiler)

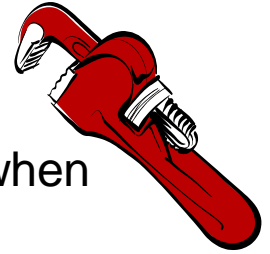

Backup wrench when
tightening fittings

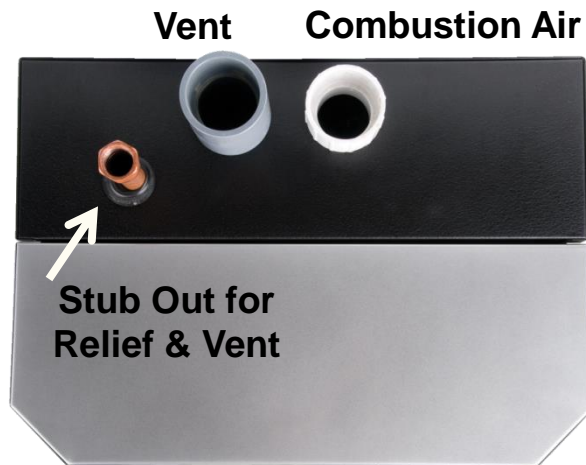

Top View

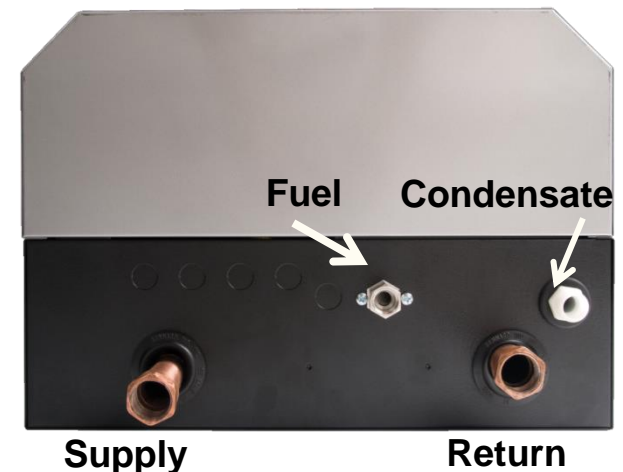

Bottom View



Rated up to 150 MAWP

- Factory supplied 30 psig relief valve
- Install safety relief valve and air vent using pipe fittings provided with the boiler
- Install $\frac{3}{4}$ " or larger discharge pipe to floor
- Install relief valve with spindle in vertical position only
- Do not install shutoff valve between boiler and safety relief valve
- Field Installed - pipe relief valve to within 6" of floor



Included with every Boiler is a complete Trim kit!

No need to purchase anything additional.



On the water side,
the only thing left to
connect is your
Supply & Return !





- Gas piping needs to be in accordance with all national and local codes
- Flexible gas line piping and gas shut off inside of boiler
- Always check gas piping and connections for leaks



1/2" NPT Gas Connection 50/75/100

3/4" NPT Gas Connection 150/200/299

Use a backup wrench when tightening

- Service shut off valve inside boiler
- Shut off valve still required external of the boiler



Gas Supply Pressure				
Capacities BTUH	Natural Gas		Propane	
	Min.	Max.	Min.	Max.
50,000 - 299,000	*3.0" w.c. (0.7kPa)	13.5" w.c. (3.3 kPa)	5.0" w.c. (1.2 kPa)	13.5" w.c. (3.4 kPa)

*Minimum gas pressure requirement of 3" w.c. – excellent for metropolitan areas with low gas pressure from the utility.

- All boilers shipped as Nat Gas. LP Kit included.
- Propane orifice conversion from natural gas in less than 5 minutes.
- Orifice to be installed for propane gas fired units
- Propane gas supply inlet pressures: 5" w.c. minimum, 13.5" w.c. maximum



Propane orifice
location 50-200

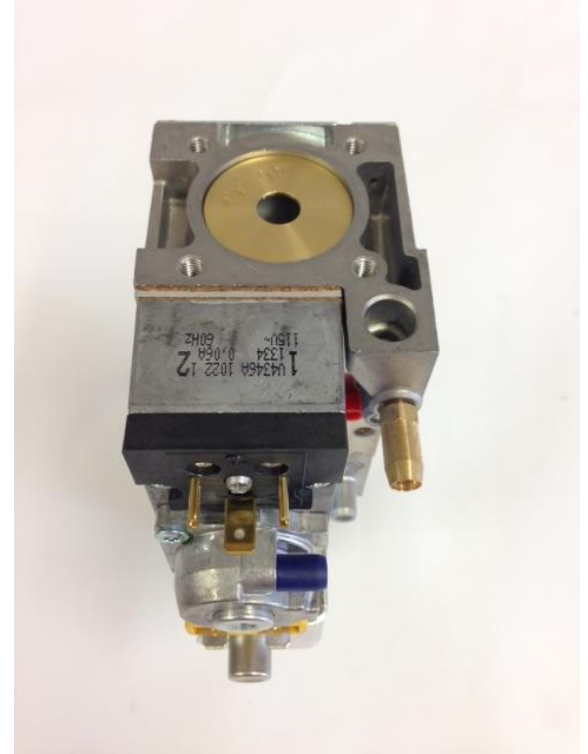
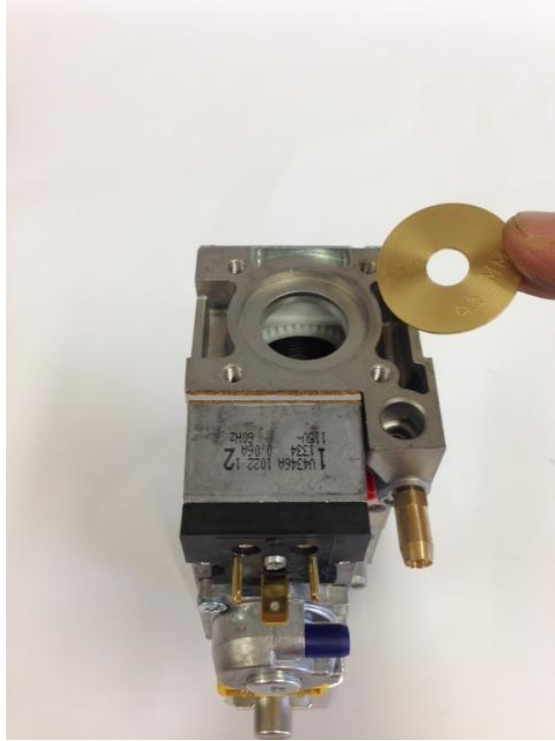
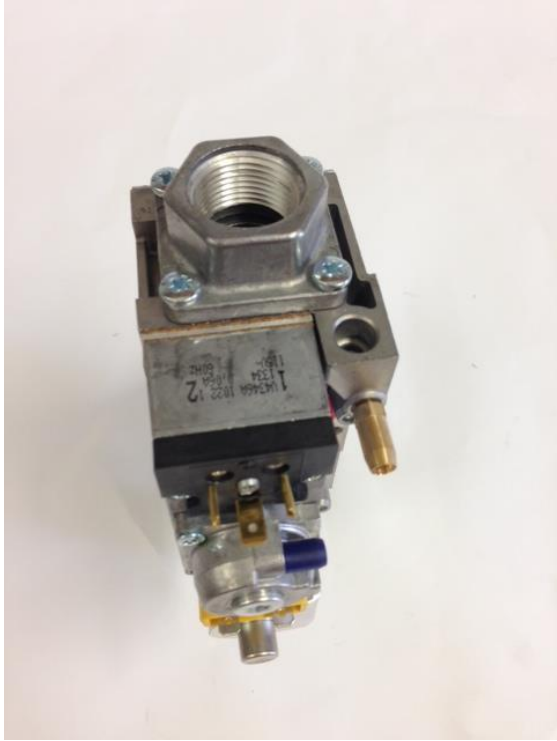

Propane orifice - 299

- Wiring connections located inside, bottom left
- Incoming 120 volt
- Central heating circulator pump
- Domestic hot water circulator pump

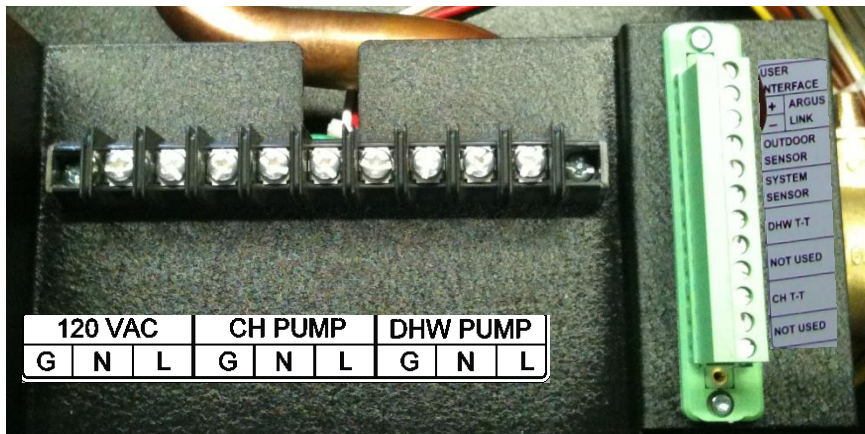
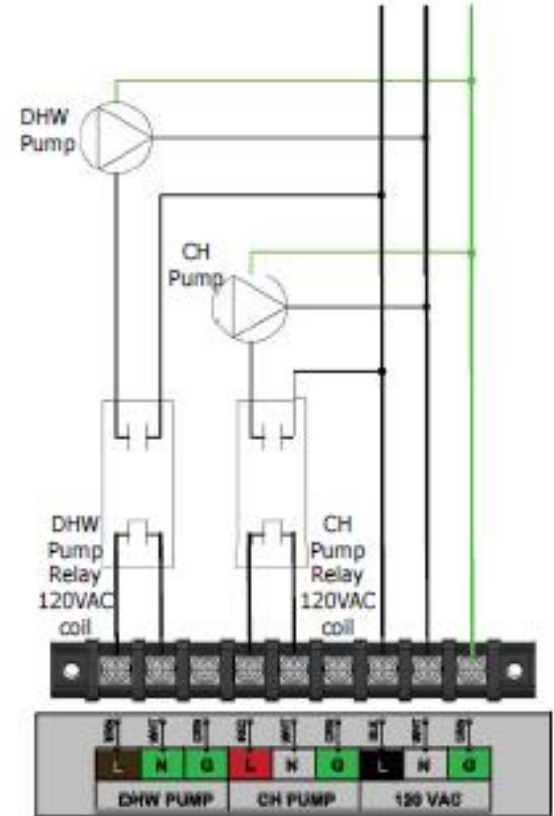

Table 11 – Maximum Allowable Current Draw

MBH	CH PUMP	DHW PUMP	NOTE
50 75 100 150 200	1 A	1 A	Powered by Control Board
299	10 A	10 A	Powered by installed 10 Amp relay

If CH or DHW pump current is more than the maximum allowable current draw install proper field sourced relays as shown in figure 8-3.

Figure 8-3 Isolation Relays for CH System Pump and DHW Pump



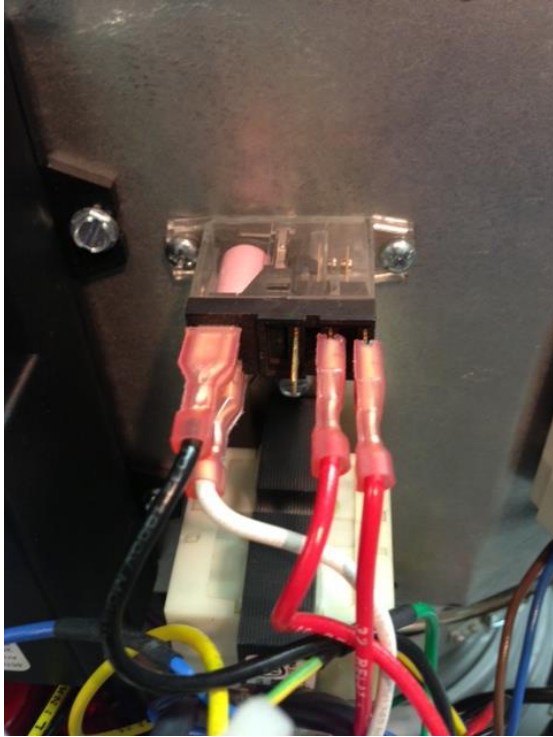

Built-in Pump Relay is provided on the 299 model.

Pending Change - 150 & 200 models will also incorporate the pump relay.

Low voltage terminal strip located inside boiler

Connections

- User Interface
- ARGUS™ Link
- Sensors
- TT – DHW / CH
- Removable for easy wiring

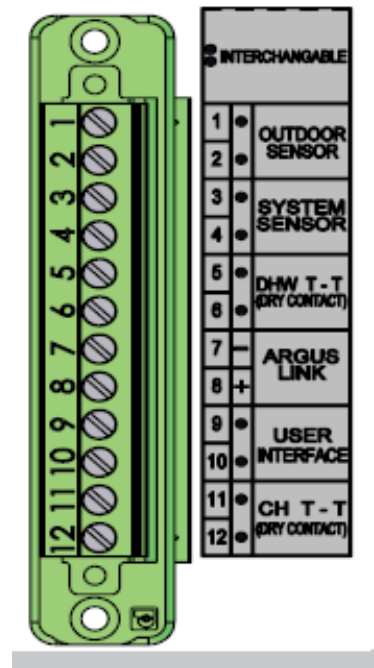

299



50-200



One Zone Heat and/or Indirect DHW

All the Wiring Will Be On Boiler

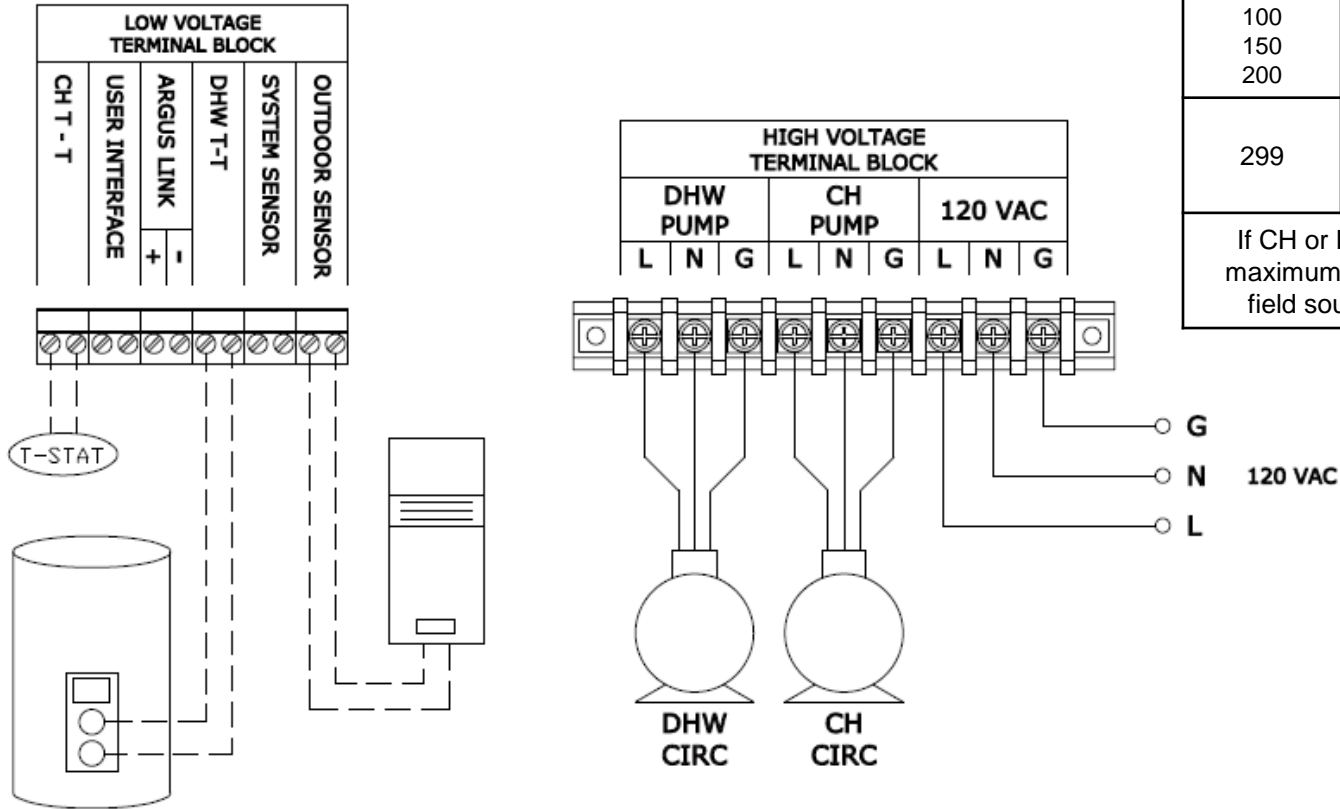
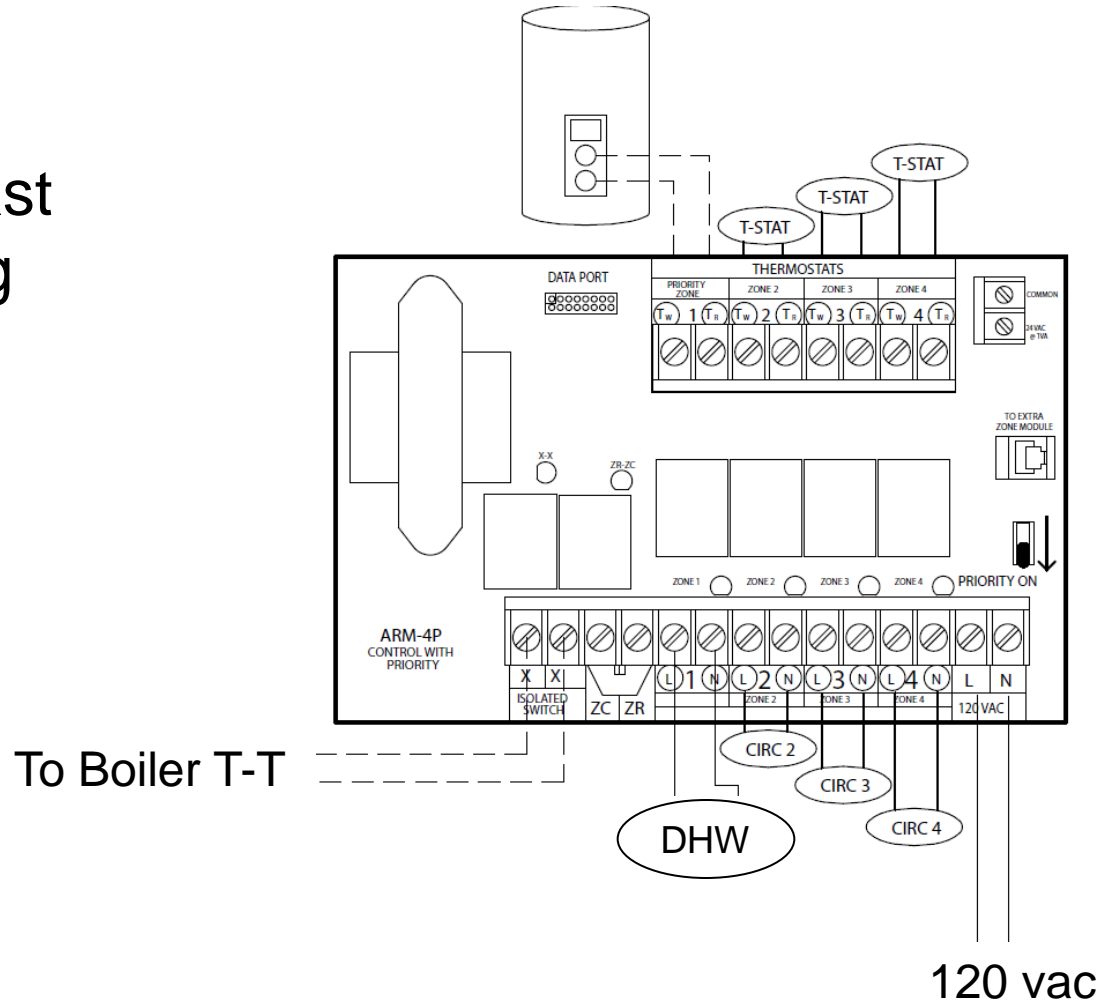

Table 11 – Maximum Allowable Current Draw

MBH	CH PUMP	DHW PUMP	NOTE
50 75 100 150 200	1 A	1 A	Powered by Control Board
299	10 A	10 A	Powered by installed 10 Amp relay
If CH or DHW pump current is more than the maximum allowable current draw install proper field sourced relays as shown in figure 8-3.			

Typical Cast Iron Wiring



If done with the SSC It will be

INCORRECT – WHY?

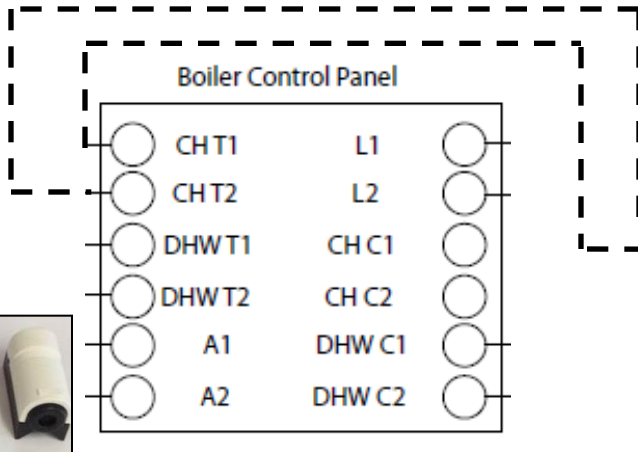
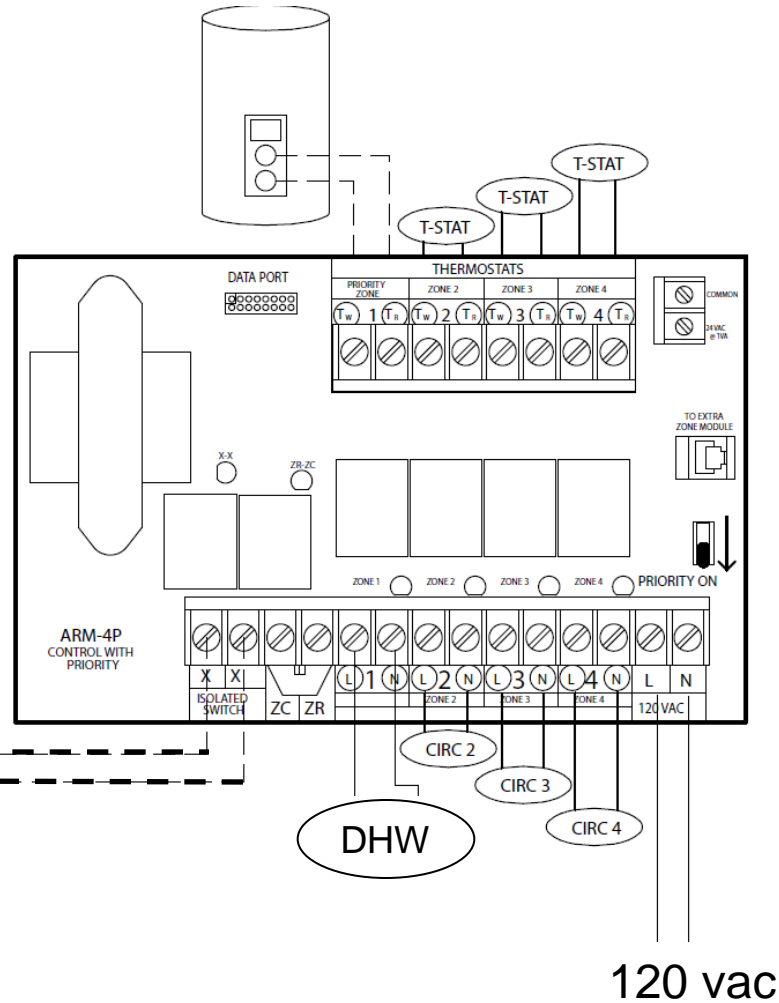

Outdoor air sensor

120 vac

If done with the SSC It will be

INCORRECT – WHY?

HINT:

Installed in December and it worked fine until this spring

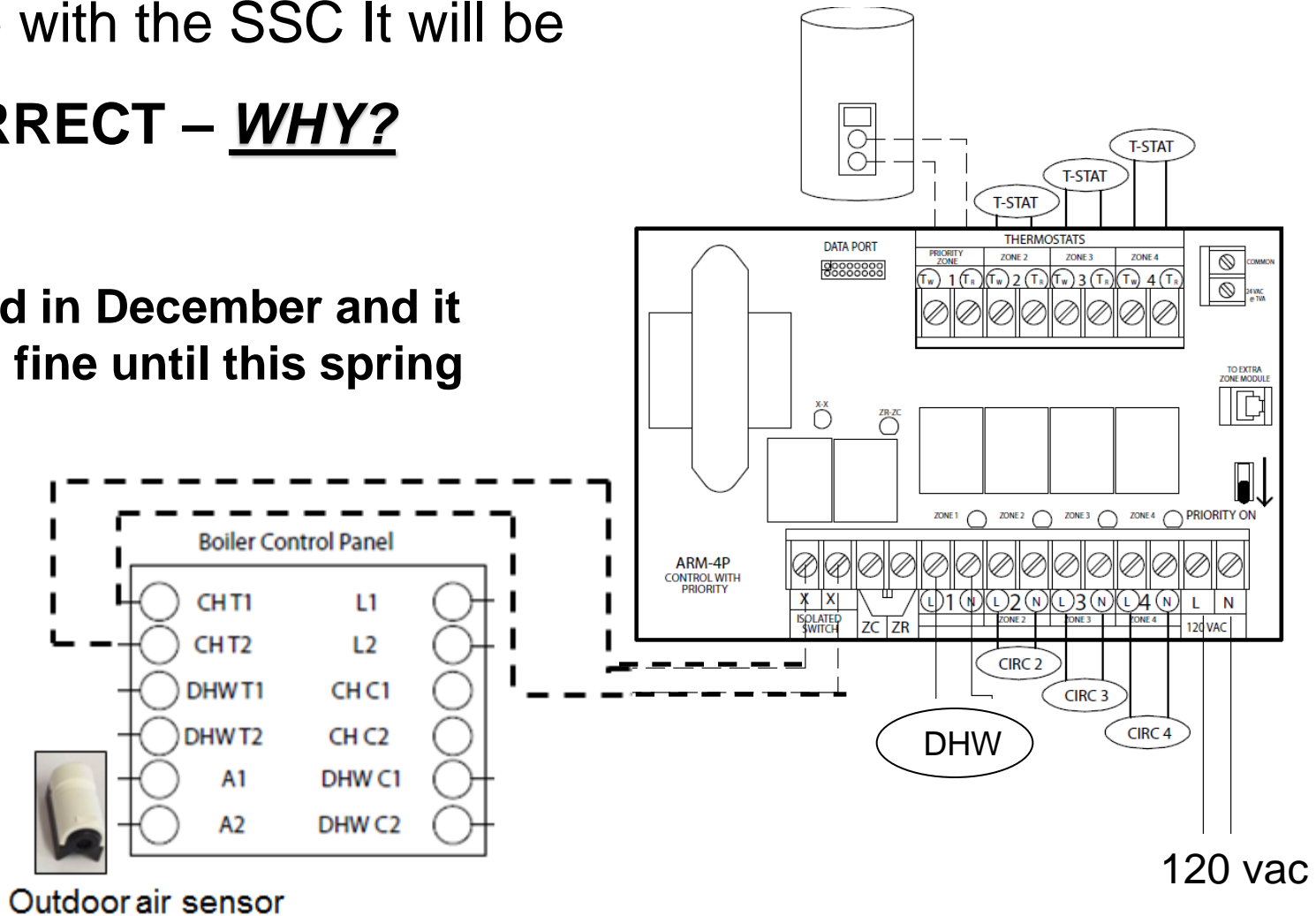

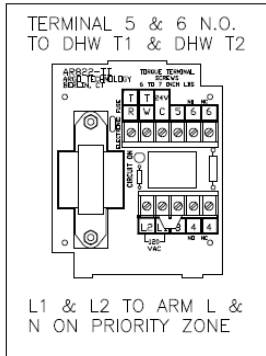

Argo AR822II can
be used as
isolation relay.

CORRECT

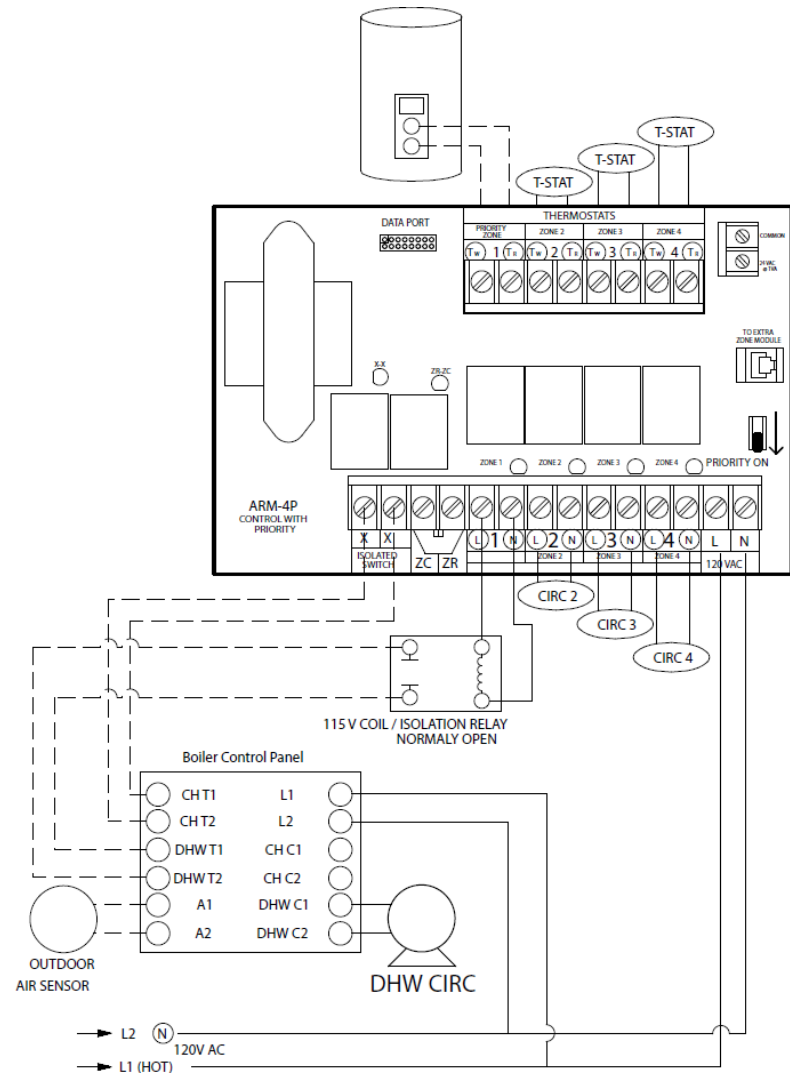

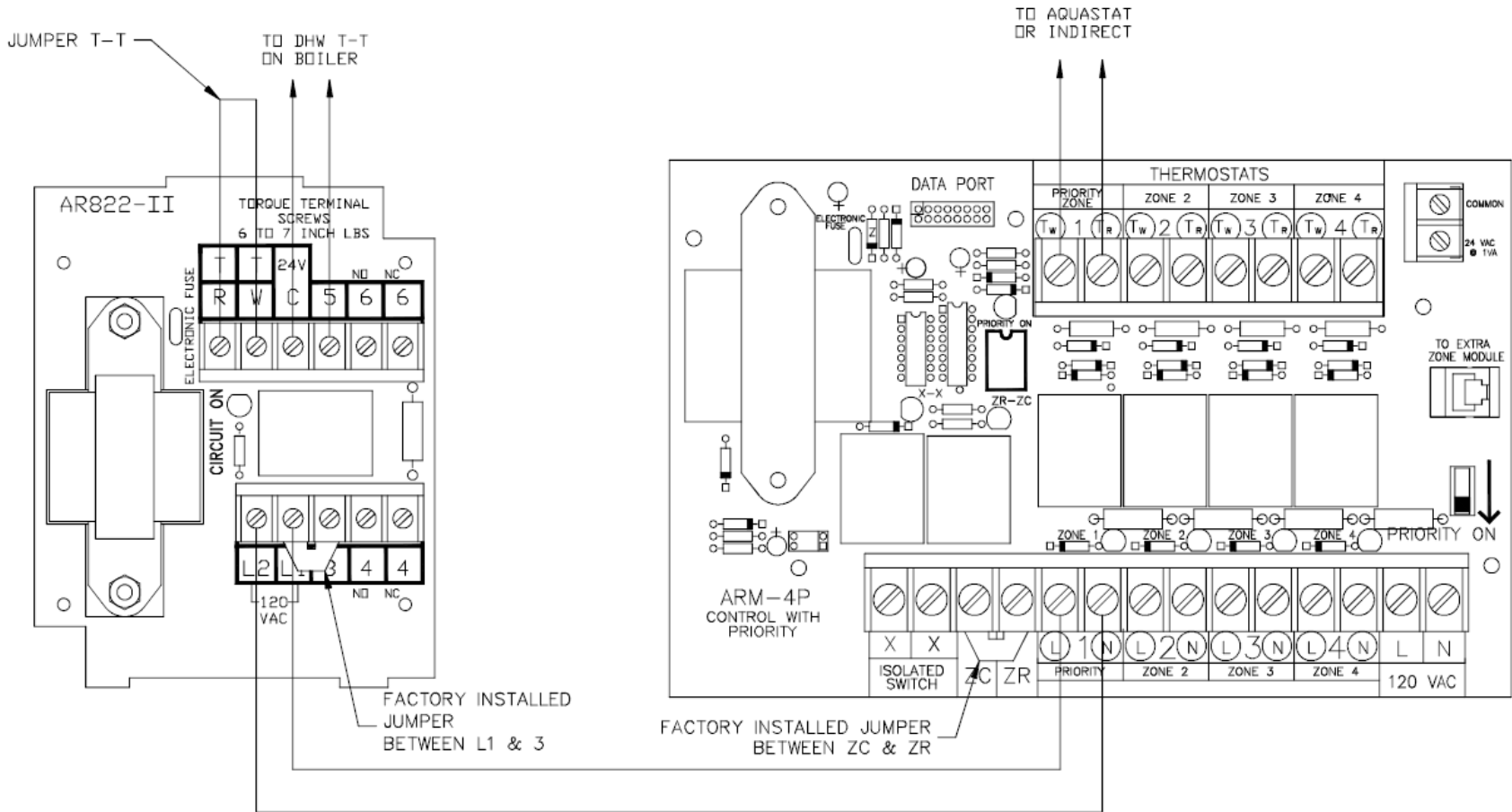

- **Multiple Boiler System**
- ARGUS™ control on first boiler will act as the master control. Requires a Multiple Boiler Install Kit p/n 550002186
- Only \$76 List
- No need for expensive MBS control
- **Wiring**
Daisy chain wiring from the master to additional boilers with low voltage wiring from the ARGUS link terminals (2-conductor low voltage wire)

FIGURE 5-8A Multiple Boiler Two Pipe Zoned System With Zone Valves - (See Multiple Boiler Guide)

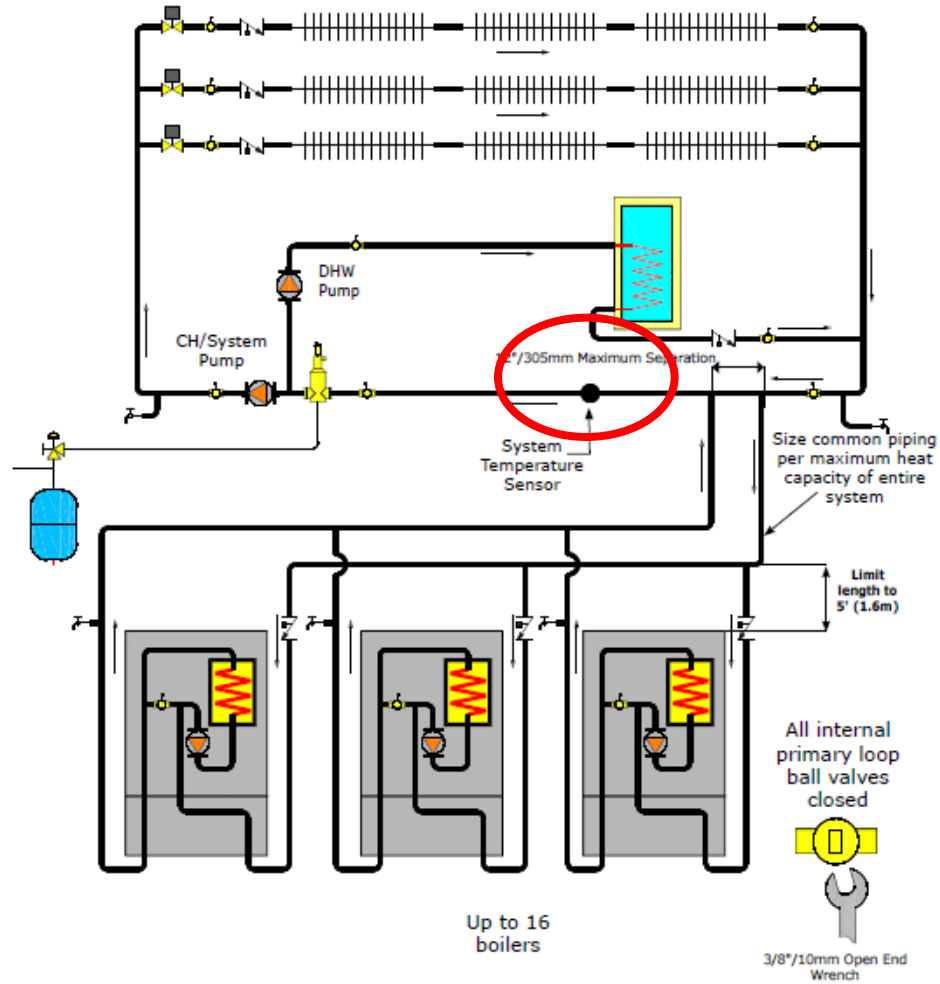



Combustion Air and Vent Pipe Equivalent Length

Model	2" Pipe		3" Pipe			4" Pipe
	050	075/100	075/100	150/200	299	299
Min.	6 ft. (1.8 m)	6 ft. (1.8 m)	6 ft. (1.8 m)	6 ft. (1.8 m)	6 ft. (1.8 m)	6 ft. (1.8 m)
Max.	100 ft. (30.5 m)	50 ft. (15.2 m)	100 ft. (30.5 m)	100 ft. (30.5 m)	25 ft. (7.7 m)	100 ft. (30.5 m)

1 - 90° elbow = 5 ft. (1.6 m)

1 - 45° elbow = 3.5 ft. (1.1 m)

1 - 2" x 3" adapter = 0 ft. (0 m)

Note: Concentric Vent Kit = 5 ft. (1.6 m) equivalent length

i.e.: Boiler can be installed on outside wall and vented with 1 - 90° elbow and 1 ft. (0.30m) of vent pipe.

- Venting to ANSI 223.1 / NFPA 54 standards
- Material - PVC / CPVC / Polypropylene, refer to IOM for additional approved vent materials and pipe schedules
- No cellular (foam core) pipe
- Utilize proper cleaner and glue
- Termination - two (2) pipe or concentric venting system

- PVC
- CPVC
- ABS
- Polypropylene

Table 4 – Combustion air and vent pipe fittings must conform with the following:		
Item	Material	Standards
Vent Pipe and Fittings	PVC schedule 40	ANSI/ASTM D1785
	PVC – DWV	ANSI/ASTM D2665
	CPVC schedule 40	ANSI/ASTM D1784/F441
	SDR-21 & SDR-26 PVC	ANSI/ASTM D2241
	ABS-DWV	ANSI/ASTM D2661
	Schedule 40ABS	ANSI/ASTM F627
	PP (Polypropylene) Pipe and Components	UL 1738 ULC S636-08
Pipe Cement / Primer	PVC	ANSI/ASTM D2564
	CPVC	ANSI/ASTM F493
	Schedule 40 ABS	ANSI/ASTM D2235
<ul style="list-style-type: none"> • IPEX is approved vent manufacturer in Canada listed to ULC-S636. • IPEX System 636 Cements and Primers are approved in Canada listed to ULC-S636 		
Use of cellular core PVC (ASTM F891), cellular core CPVC, or Radel®, (Polyphenolsulfone) in venting systems shall be prohibited.		

FIGURE 6-7 Concentric Roof Terminal

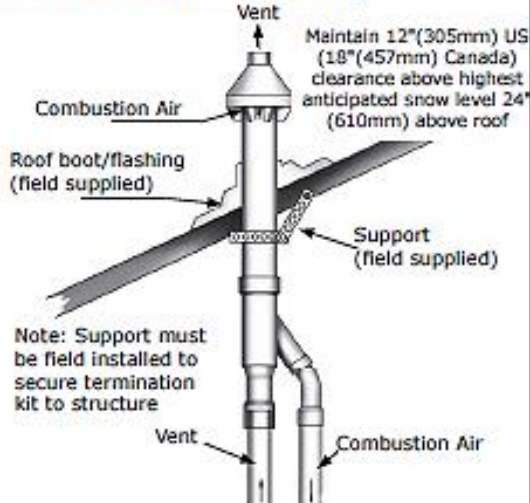

Roof w/ Concentric combustion air

FIGURE 6-8 Flue on Roof. Air Intake on Side Wall

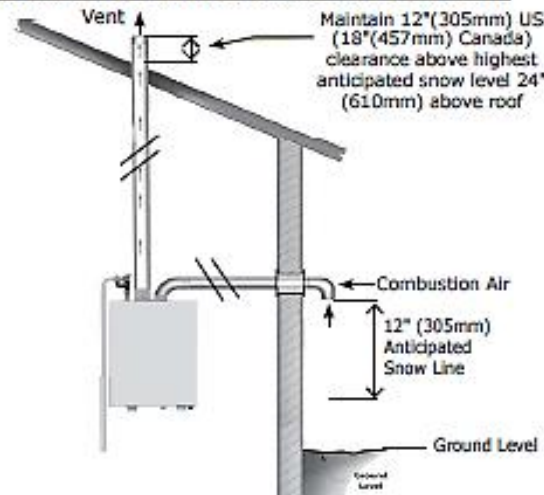

Roof w/ sidewall combustion air

FIGURE 6-9 Flue on Roof. Combustion Air

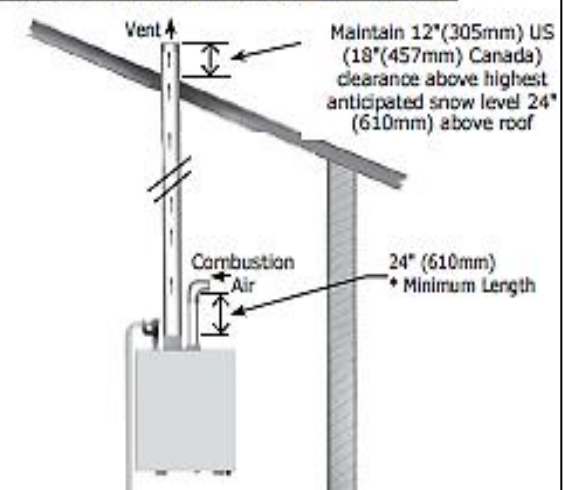

Roof w/ inside combustion air

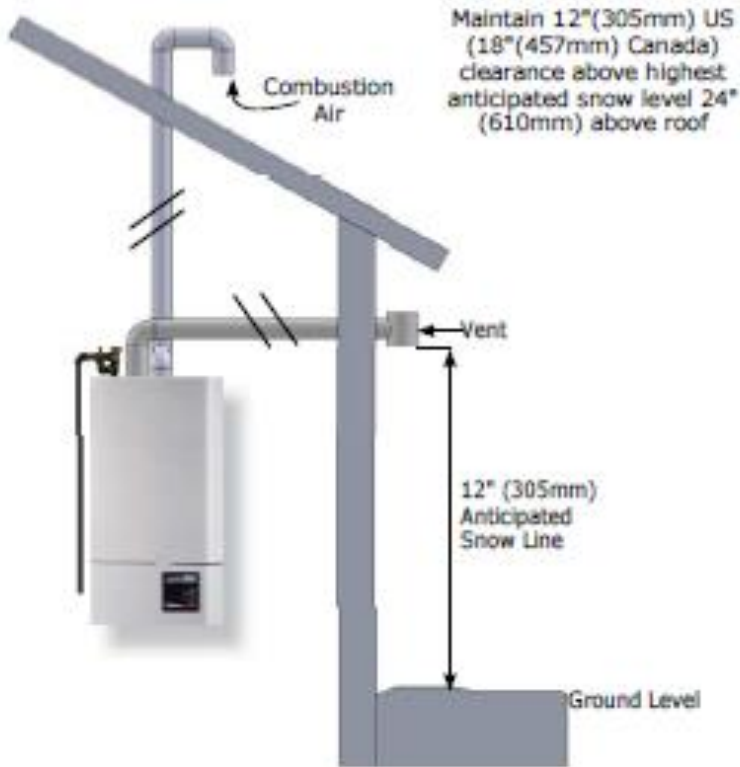

Sidewall vent w/
combustion air on roof

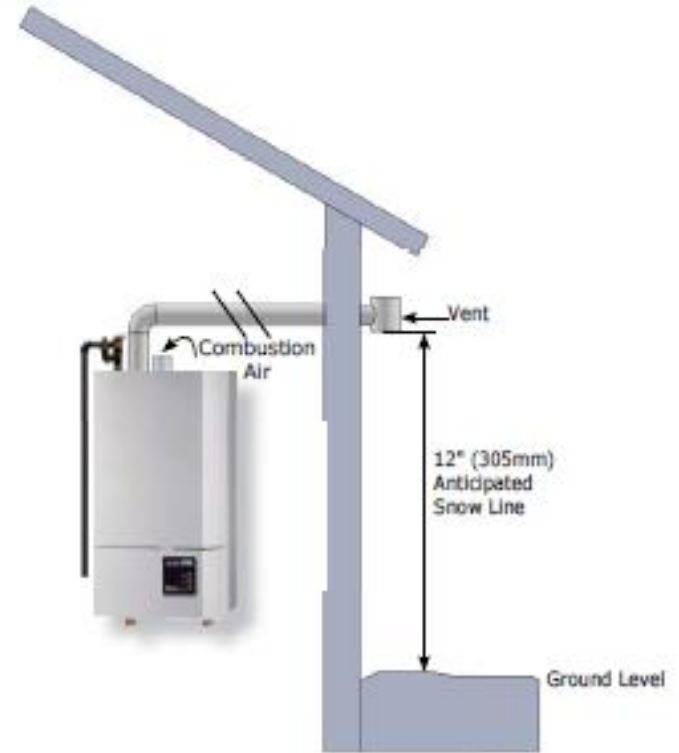

Sidewall vent w/
inside combustion air

FIGURE 6-1 Two Pipe Roof Vent

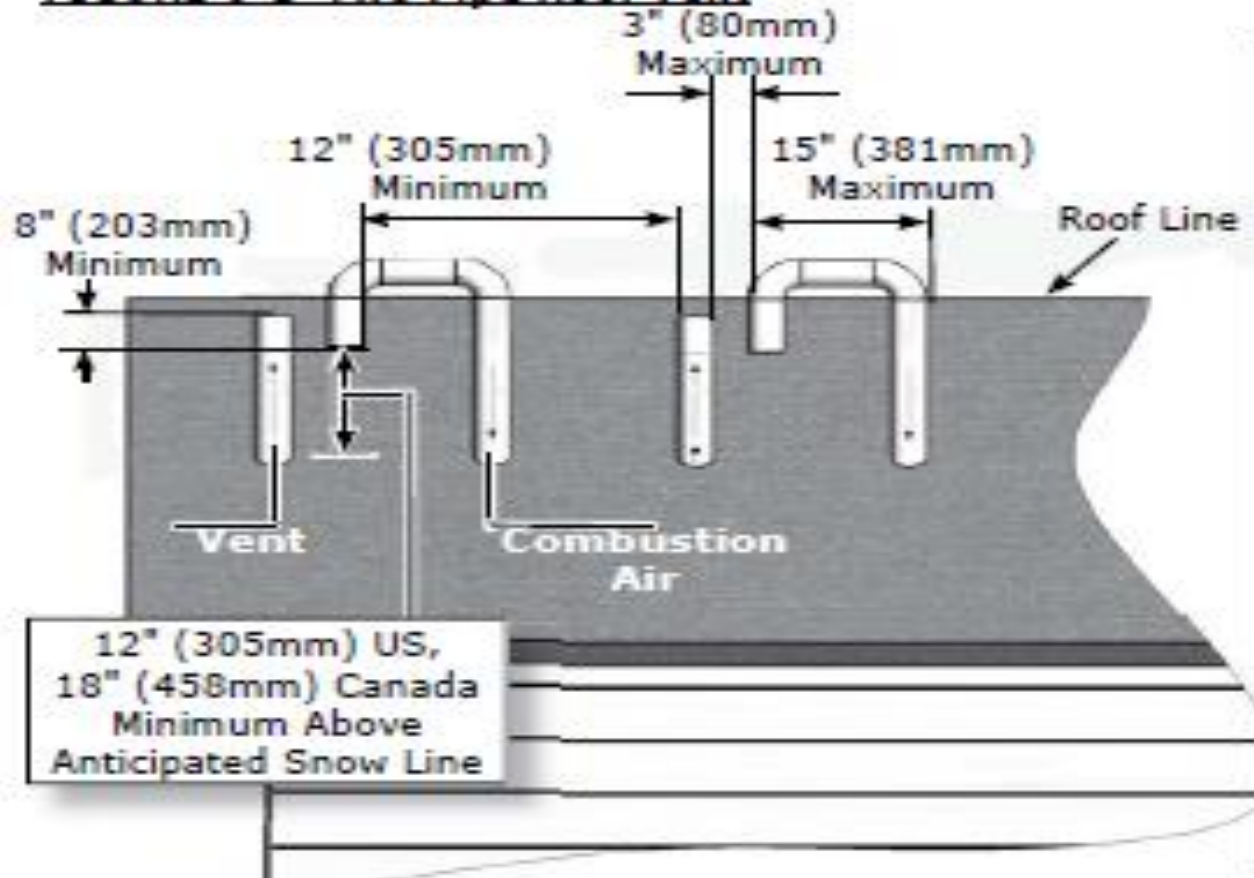

FIGURE 6-2 Two Pipe Side Wall Vent

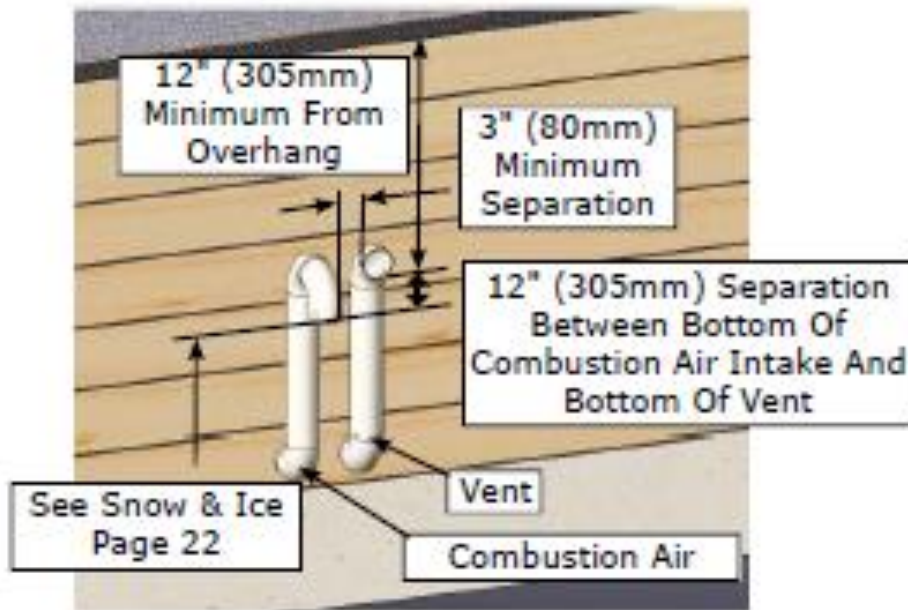
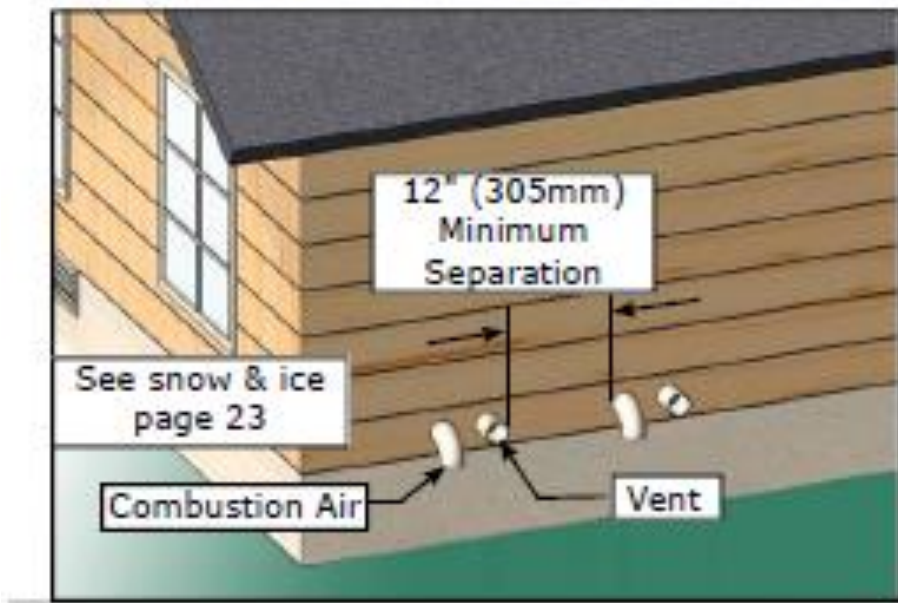

FIGURE 6-3 Two Pipe Side Wall Vent (Multiple Appliances)



Note: Flow Check Valve accessory required – kit number 240010299

FIGURE 6-17 Multiple Boilers With Common Venting Pipe

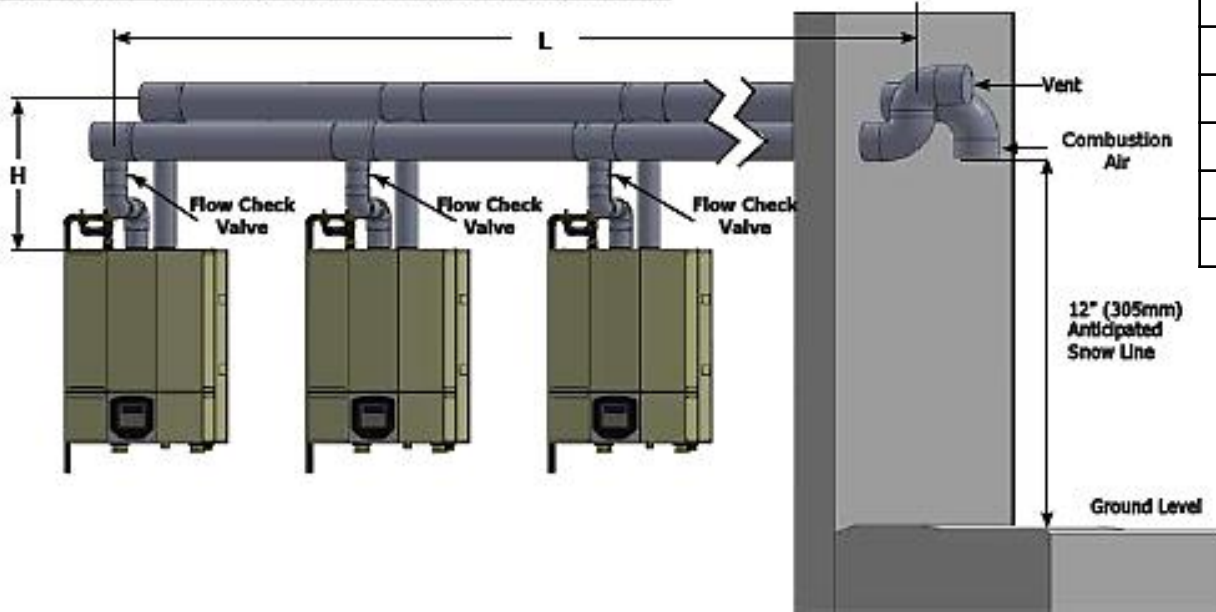
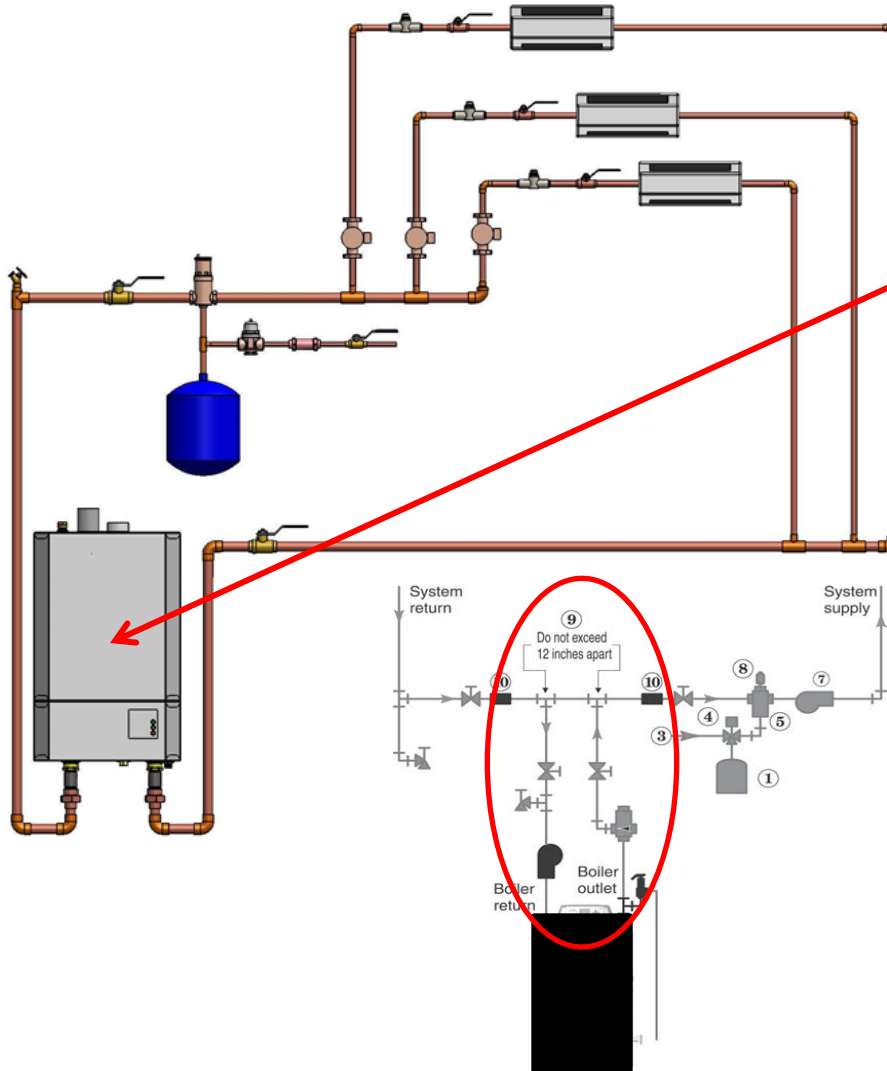

Table 9 – Common Venting Pipe Diameters

Total Firing Rate	Minimum Diameter of Common vent pipes if L <50 ft (16m)	Minimum Diameter of Common vent pipes if L >50 ft (16m)
400	4" (101mm)	5" (127mm)
600	5" (127mm)	6" (152mm)
800		
1000	6" (152mm)	7" (177mm)
1200		
1400		
1600	7" (177mm)	8" (203mm)
1800		
2000		

- Side wall or roof venting systems allowed
- 1' from or below doors, windows / gravity inlets **except** when using indoor air for combustion. 4' clearance required for single pipe installations. **Direct vent on common wall only**
- 3' above and 10' from any forced air inlet
- Above expected Snow grade (12")
- 3' from a inside "L" corner
- 4' horizontally from, no case above or below electrical, gas meter / regulators or relief equipment
- Cannot be vented under a deck or porch



Primary/Secondary Piping and Pump

Factory installed inside the boiler.

The internal pump provides the correct amount of water flow through the heat exchanger.

The pressure drop across the boiler's supply and return line is negligible - the boiler is not adding resistance to the system piping.

FIGURE 5-6 Single Boiler Two-Pipe Zoned System With Zone Pumps

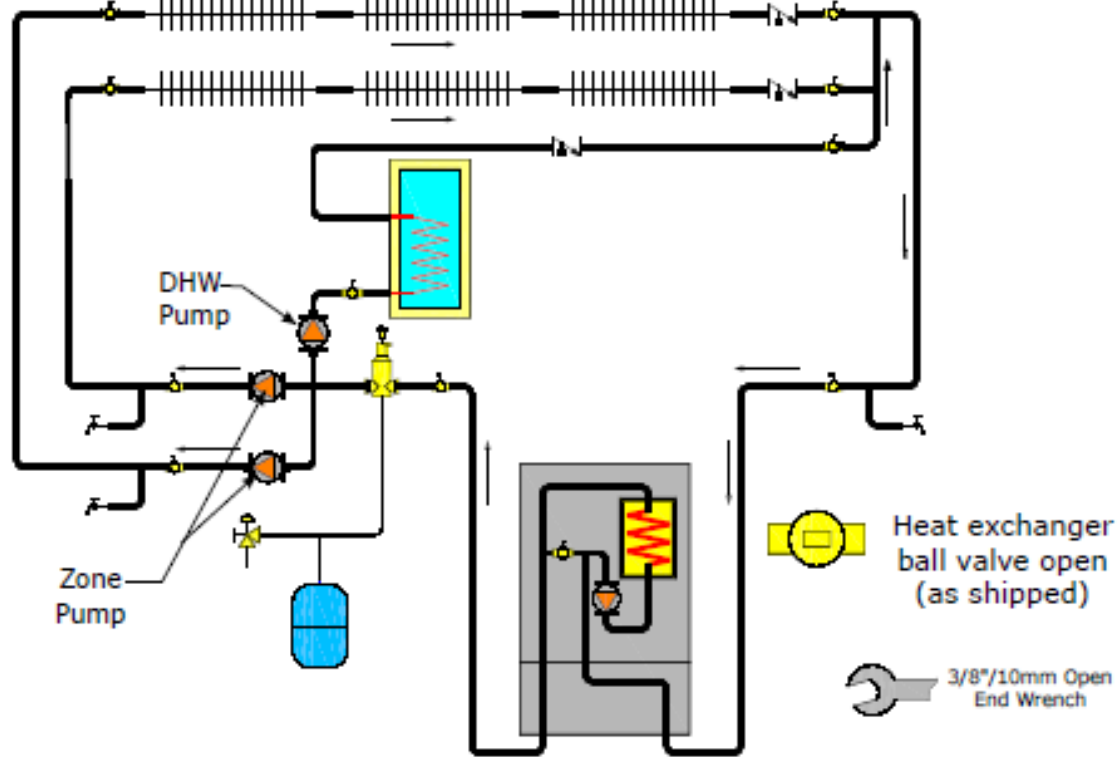

Boiler is shipped with the heat exchanger ball valve open.
Connect to existing systems without extensive re-piping or the
need to purchase a high head pump.

FIGURE 5-7A Single Boiler Using Primary/Secondary Pumping With Closed External Primary Loop

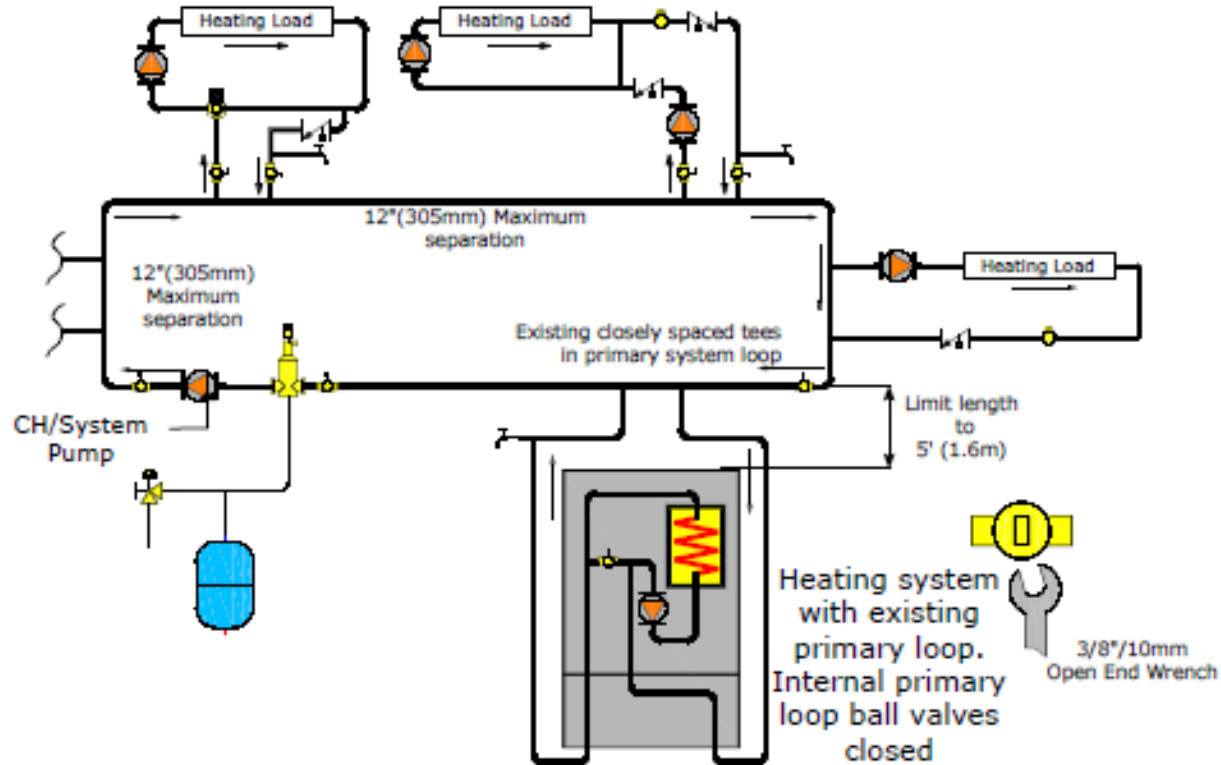
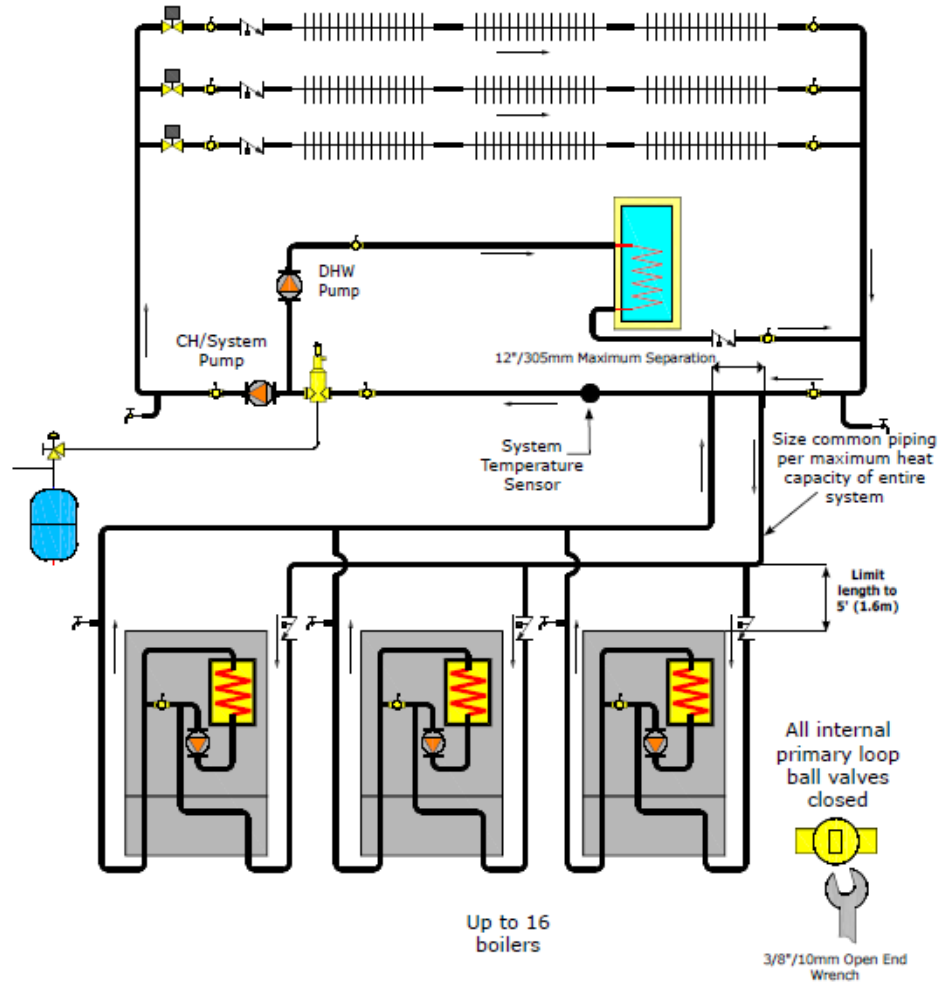
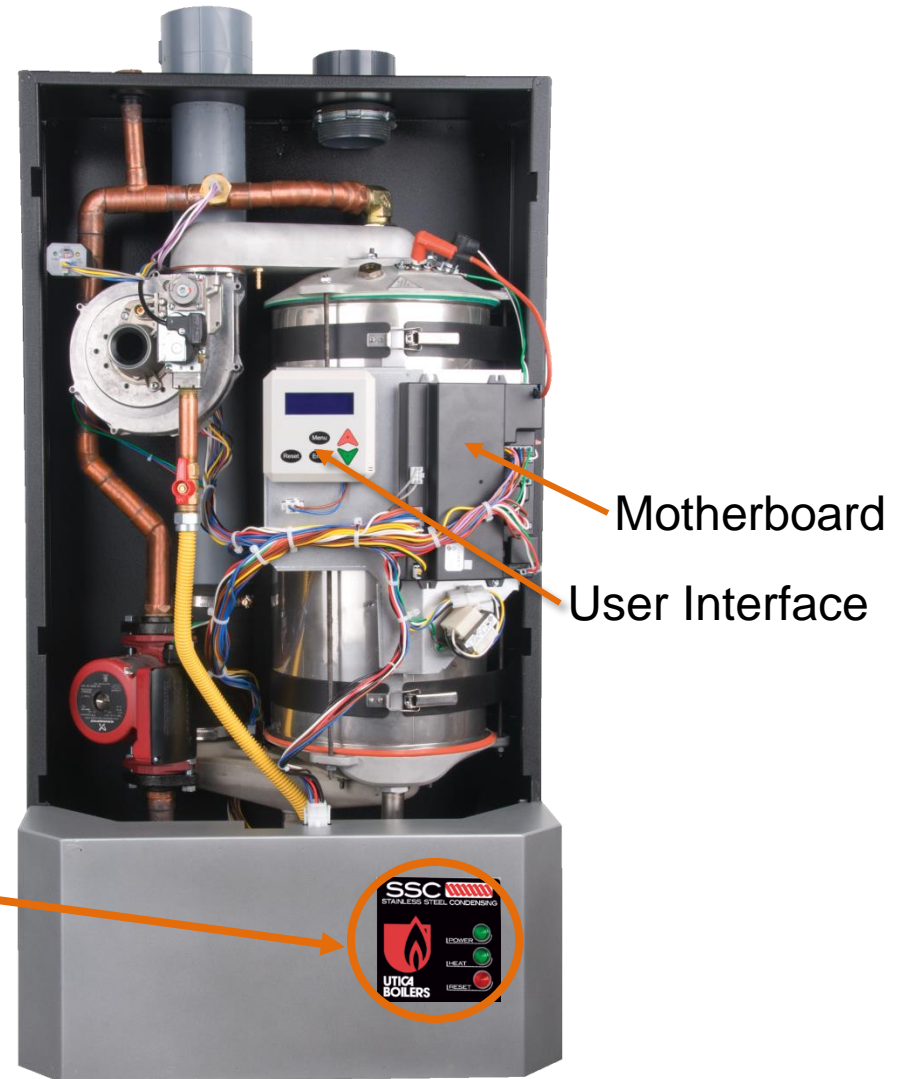

FIGURE 5-8A Multiple Boiler Two Pipe Zoned System With Zone Valves - (See Multiple Boiler Guide)



- ARGUS™
- Display / mother board
- Fuse protected
- Status Lights



- Key Features:
 - User Interface with full text readout of error codes + diagnostics.
 - Integrated Multiple boiler control w/ simplified physical connection.



S t a n d b y : N o D e m a n d
7 5 ° F

F P B G

C e n t r a l H e a t i n g
6 5 % 9 5 ° F

F P B G D

D o m e s t i c H o t W a t e r
9 5 % 1 6 5 ° F

Boiler operates in standby mode until demand for Central Heat (CH) or Domestic Hot Water (DHW) is detected.

Boiler Status Indicator

F = Flame Detected

P = Boiler Pump On

B = Combustion Air Blower

S = Spark Ignition On

G = Gas Valve Open

D = DHW Pump On



```
F P B S G D
S e r v i c e   R e m i n d e r
S t a n d b y :   N o   D e m a n d
                                     7 5 ° F
```

Service Reminder Indicator

Boiler in Standby Mode

Boiler Supply Water

Temperature Indicator



ARGUS™ Control

Key	Description
RESET	Reset Control / System
MENU	Enter / Exit user menu
ENTER	Select Menu item Confirm new parameter value
▲ PLUS	Scroll up to next menu item Go to next screen Increase value
▼ MINUS	Scroll down to next menu item Go to previous screen Decrease value

**EASY TO PROGRAM
EASY TO UNDERSTAND**

TWO MENU'S: MAIN MENU & INSTALLERS MENU

Main Menu

**Boiler
Status**



Settings

Boiler Status

Supply Temperature Setpoint

Supply Temperature

Return Temperature

DHW Status

**System (Sensor) N.C. (Not
Connected)**

Flue Temperature

Outside Air Temperature

Boiler Pump

CH/System Pump

DHW Pump

Key	Description
RESET	Reset Control / System
MENU	Enter / Exit user menu
ENTER	Select Menu item Confirm new parameter value
▲ PLUS	Scroll up to next menu item Go to next screen Increase value
▼ MINUS	Scroll down to next menu item Go to previous screen Decrease value

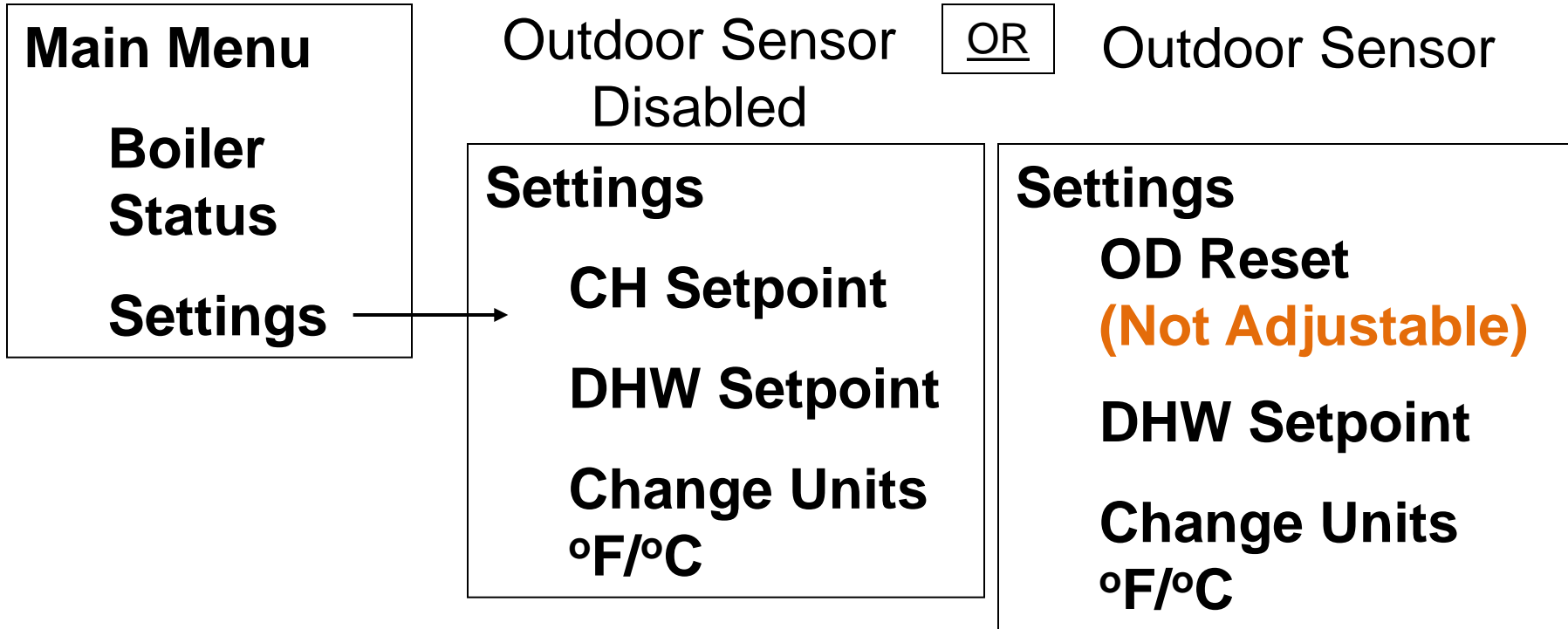

Key	Description
RESET	Reset Control / System
MENU	Enter / Exit user menu
ENTER	Select Menu item Confirm new parameter value
▲ PLUS	Scroll up to next menu item Go to next screen Increase value
▼ MINUS	Scroll down to next menu item Go to previous screen Decrease value

Sample Screen Display

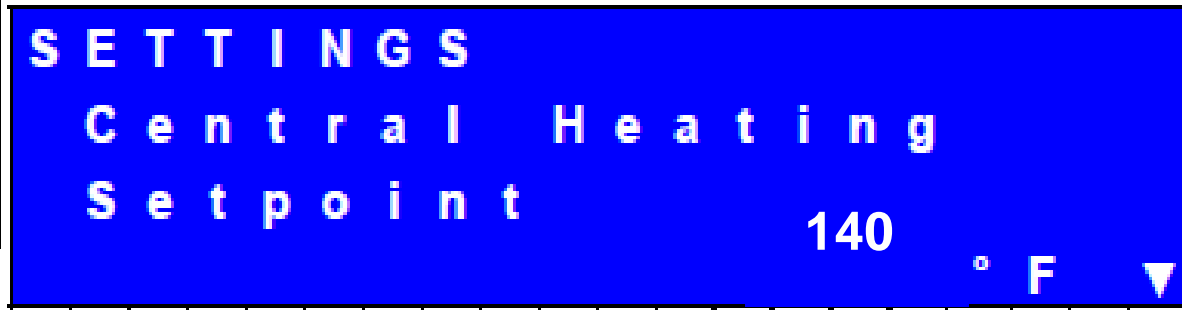

(Menu & Enter Buttons – 4 seconds)

Installer Menu

Boiler Status

Boiler Config

CH Settings

DHW Settings

**Cascade
Settings**

System Test

Boiler Status

**Fan Speed – Actual, Low, IGN,
High**

Flame

Signal

Failures

Ignition Attempts

Successful

Failed

Boiler Run Time

CH – hours

DHW – hours

**Blocking Errors (non-volatile
memory for 16)**

**Locking Errors (non-volatile
memory for 16)**

Key	Description
RESET	Reset Control / System
MENU	Enter / Exit user menu
ENTER	Select Menu item Confirm new parameter value
▲ PLUS	Scroll up to next menu item Go to next screen Increase value
▼ MINUS	Scroll down to next menu item Go to previous screen Decrease value

(Menu & Enter Buttons – 4 seconds)

Installer Menu

Boiler Status

Boiler Config →

CH Settings

DHW Settings

**Cascade
Settings**

System Test

Boiler Config

Address Selection

LWCO – enable/disable

Pump Mode

CH or Ch & DHW - 0

System Pump - 4

Service Reminder

On/Off

Duration

Key	Description
RESET	Reset Control / System
MENU	Enter / Exit user menu
ENTER	Select Menu item Confirm new parameter value
▲ PLUS	Scroll up to next menu item Go to next screen Increase value
▼ MINUS	Scroll down to next menu item Go to previous screen Decrease value

(Menu & Enter Buttons – 4 seconds)

Installer Menu

Boiler Status

Boiler Config

CH Settings

DHW Settings

**Cascade
Settings**

System Test

→ **CH Settings**

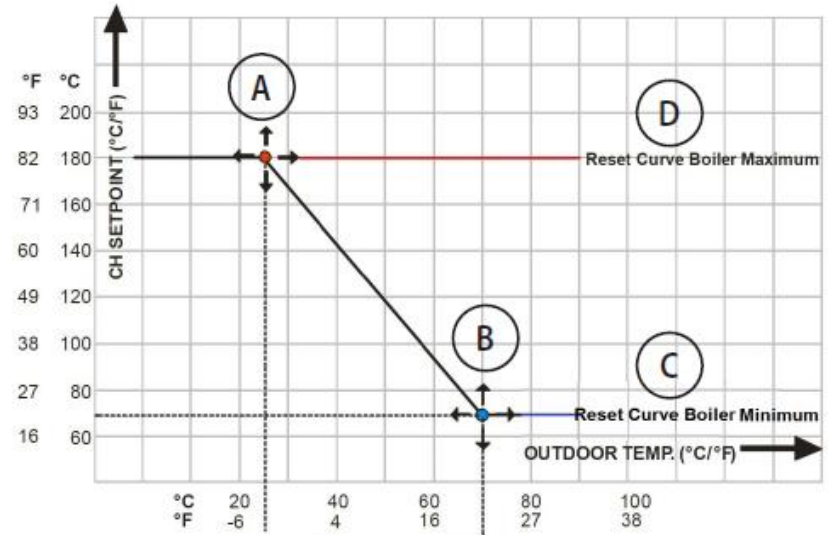

CH Mode

- 0- CH with Tstat
- 1- CH: Tstat & Outdoor Sensor
- 2- CH: No Tstat, Full setback by OAS
- 3- CH: Permanent Demand

Warm Weather Shutdown (70) *

Reset Curve Design – High end (180 @ 25)*

Reset Curve Design – Low end (100 @ 70) *

Reset Curve Min/Max Temperatures (180/70) *

Boost Function

Max Power

***Defaults**

Key	Description
RESET	Reset Control / System
MENU	Enter / Exit user menu
ENTER	Select Menu item Confirm new parameter value
▲ PLUS	Scroll up to next menu item Go to next screen Increase value
▼ MINUS	Scroll down to next menu item Go to previous screen Decrease value

(Menu & Enter Buttons – 4 seconds)

Installer Menu

Boiler Status

Boiler Config

CH Settings

DHW Settings

**Cascade
Settings**

System Test

DHW Settings

DHW Mode

DHW Priority (Default – 30 min)

Key	Description
RESET	Reset Control / System
MENU	Enter / Exit user menu
ENTER	Select Menu item Confirm new parameter value
▲ PLUS	Scroll up to next menu item Go to next screen Increase value
▼ MINUS	Scroll down to next menu item Go to previous screen Decrease value

(Menu & Enter Buttons – 4 seconds)

Installer Menu

Boiler Status

Boiler Config

CH Settings

DHW Settings

**Cascade
Settings**

System Test

Cascade Settings

Emergency Setpoint

Start Delay Time

Stop Delay Time

Start Boiler Differential

Stop Boiler Differential

Calculated Setpoint: Max Offset Up

**Calculated Setpoint: Max Offset
Down**

Next Boiler Start Rate

Next Boiler Stop Rate

Rotation Interval

Boilers for DHW

Start Modulation Delay Factor

System Pump – Post Pump Time

Key	Description
RESET	Reset Control / System
MENU	Enter / Exit user menu
ENTER	Select Menu item Confirm new parameter value
▲ PLUS	Scroll up to next menu item Go to next screen Increase value
▼ MINUS	Scroll down to next menu item Go to previous screen Decrease value

(Menu & Enter Buttons – 4 seconds)

Installer Menu

Boiler Status

Boiler Config

CH Settings

DHW Settings

**Cascade
Settings**

System Test

System Test Settings

System test power: (Low, IGN, High)

Boiler Pump (On / Off)

CH Pump (On / Off)

DHW Pump (On / Off)

Key	Description
RESET	Reset Control / System
MENU	Enter / Exit user menu
ENTER	Select Menu item Confirm new parameter value
▲ PLUS	Scroll up to next menu item Go to next screen Increase value
▼ MINUS	Scroll down to next menu item Go to previous screen Decrease value



Error Code Troubleshooting





Error Code Troubleshooting

Current System Status

----- Lockout Alarm Blocking Too Long Error	A 0 0	Go to Page 40	F P _ _ _ _ Blocking Error False Flame Detect	E 3 5	Go to Page 44
----- Lockout Alarm Ignit Error	A 0 1	Go to Page 41	----- Blocking Error Low Water Cutoff	E 3 6	Go to Page 45
----- Lockout Alarm GV Relay Error	A 0 5	Go to Page 40	----- Blocking Error Return Temp	E 4 0	Go to Page 46

Error Description

Error Code #
Page # in IOM

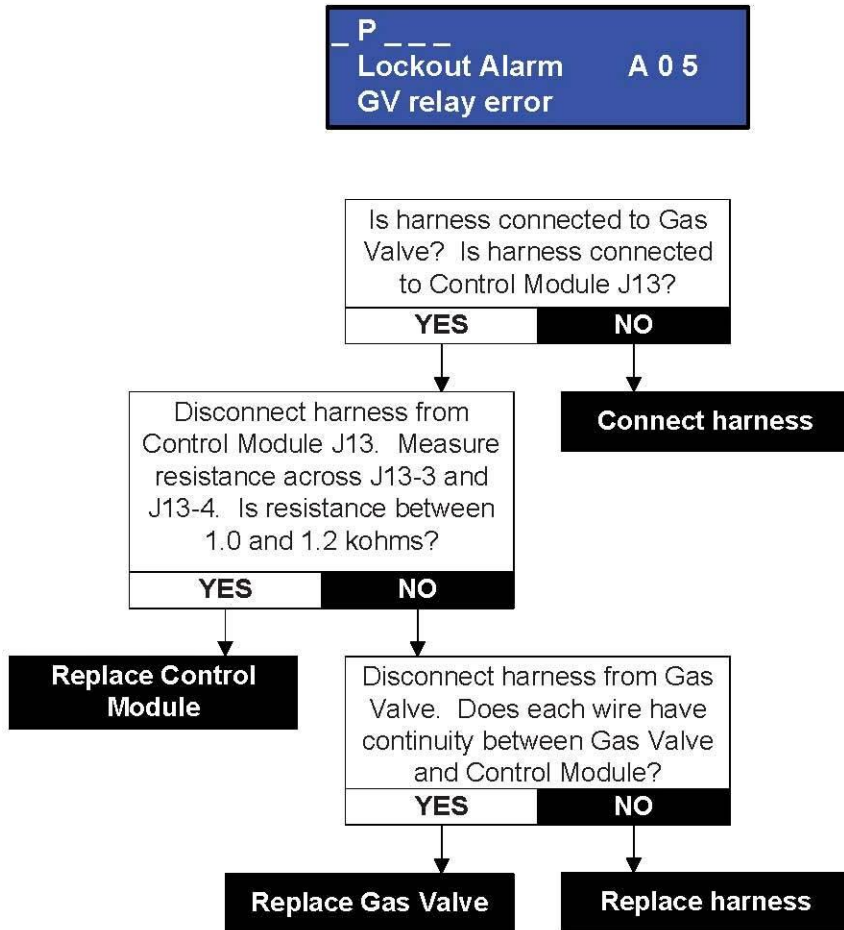

- Flow chart design
- Easy to follow and understand
- Step by step procedure
- Error code listed in blue box



Combustion Requirements



- Combustion and proper installation set up required for all high efficiency models
 - **Combustion Analyzer** - Properly check CO² level of exhaust
 - **Gas Meter** – U-tube manometer or gauge set to check inlet gas pressure
 - To change gas inlet pressure adjust at system regulator **NOT** THE GAS VALVE REGULATOR
 - **Sampling port located on Flue Collector**
- No need to drill sample port in flue pipe!!*

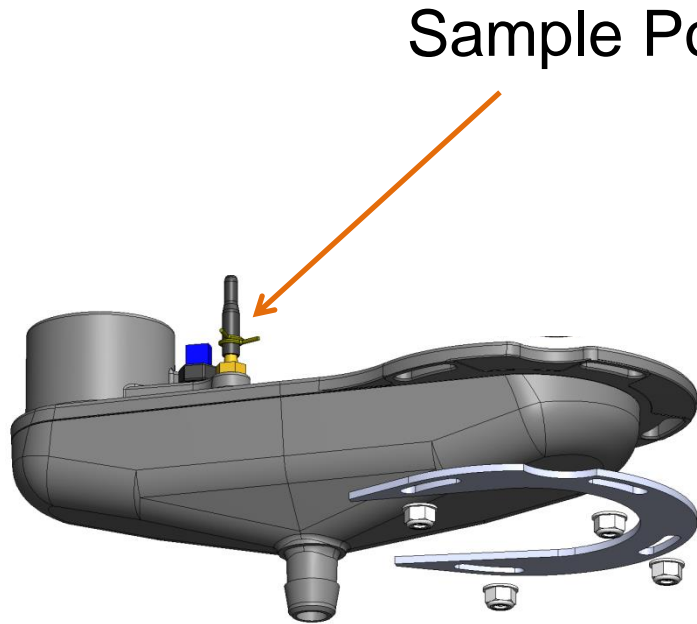

Combustion Gas Valve on 50-200 models

Gas	CO2		CO
	Min	Max	
Natural Gas	9.0	9.5	<200ppm
Propane	10.0	11.0	<200ppm

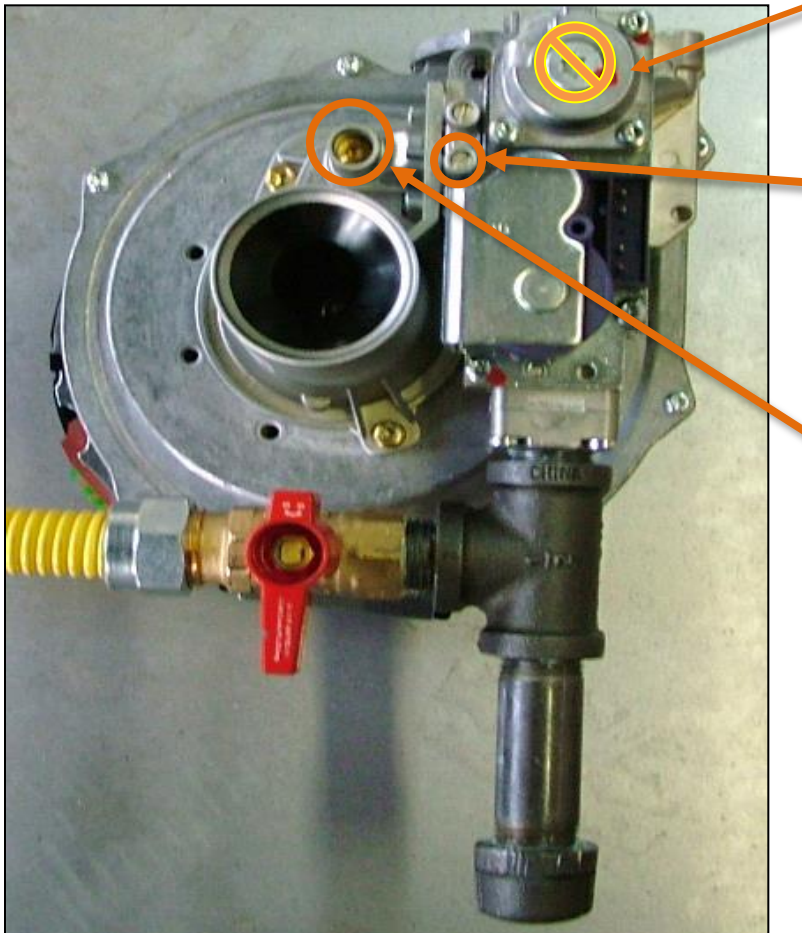

- Do not adjust the gas regulator on the gas valve
- Gas inlet pressure tap
Natural: 3" – 13.5" w.c.
LP: 5" – 13.5" w.c.
- Throttle screw – to adjust the air / gas mixture on the venturi assembly
- All gas pressure changes are done at the utility regulator external of the equipment

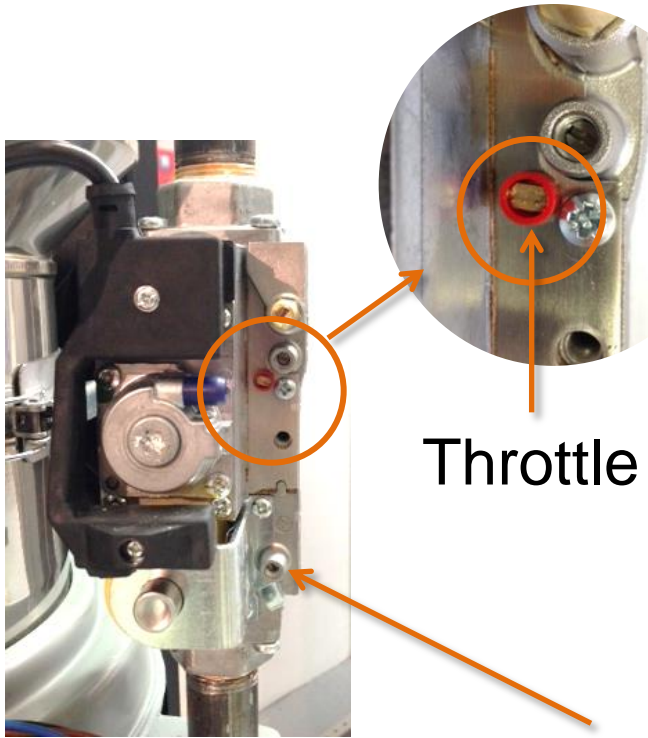

Throttle Screw (red)

Gas Inlet Pressure Tap

Gas	CO ₂		CO
	Min	Max	
Natural Gas	9.0	9.5	<200ppm
Propane	10.0	11.0	<200ppm



Maintenance/Cleaning



- Turn off gas and electrical
- Remove blower / burner assembly and examine flue passageways
- Remove igniter and sensor off top of heat exchanger
- Burner may be cleaned by using compressed air, nitrogen or CO₂ tank.

- Clean heat exchanger with nylon brush if required
- Any remaining sediment can be removed with a shop vacuum snorkel
- Re-install refractory and burner / gas valve
- Visually inspect condensate trap – re-fill trap (If required)



Critical Installation Points



Getting the Air Out



- Air in the system affects Low Mass Boilers differently than cast iron boilers
- Heat Exchanger Water Volume is much lower
- Air removal methods different
- Water Flow rates are important
- How does Antifreeze affect the System?
- Clean Water

Getting the Air Out



- Cast Iron Boilers are more tolerant of system air issues.
- Gravity works for us



Cast Iron Air Scoop

- Based on venturi principal; accelerated flow yields reduced pressure, causing dissolved gases to separate
- Slow Process – Less Effective
- Proper location Critical for air scoop to remove air



Micro-Bubble Separator

- Based on the principal that reduced velocity plus multiple impact sites allow air bubbles to separate easily
- Faster process, much more effective
- Location Not Critical for Separator to function

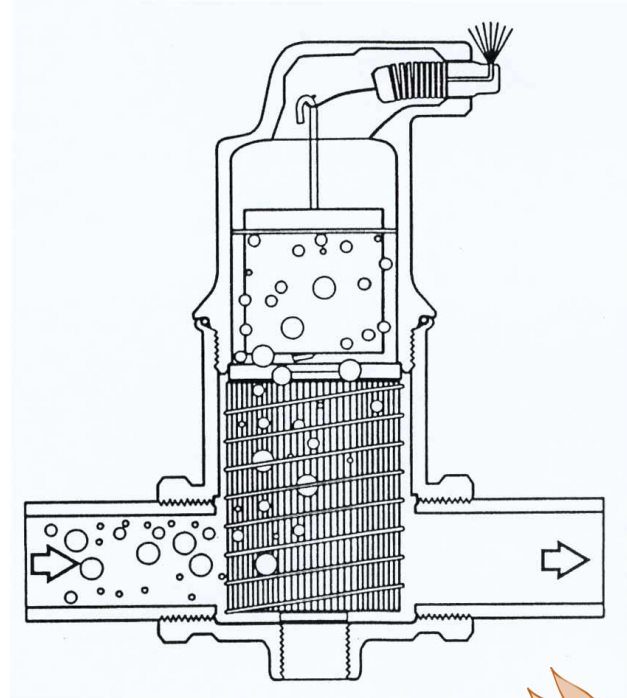
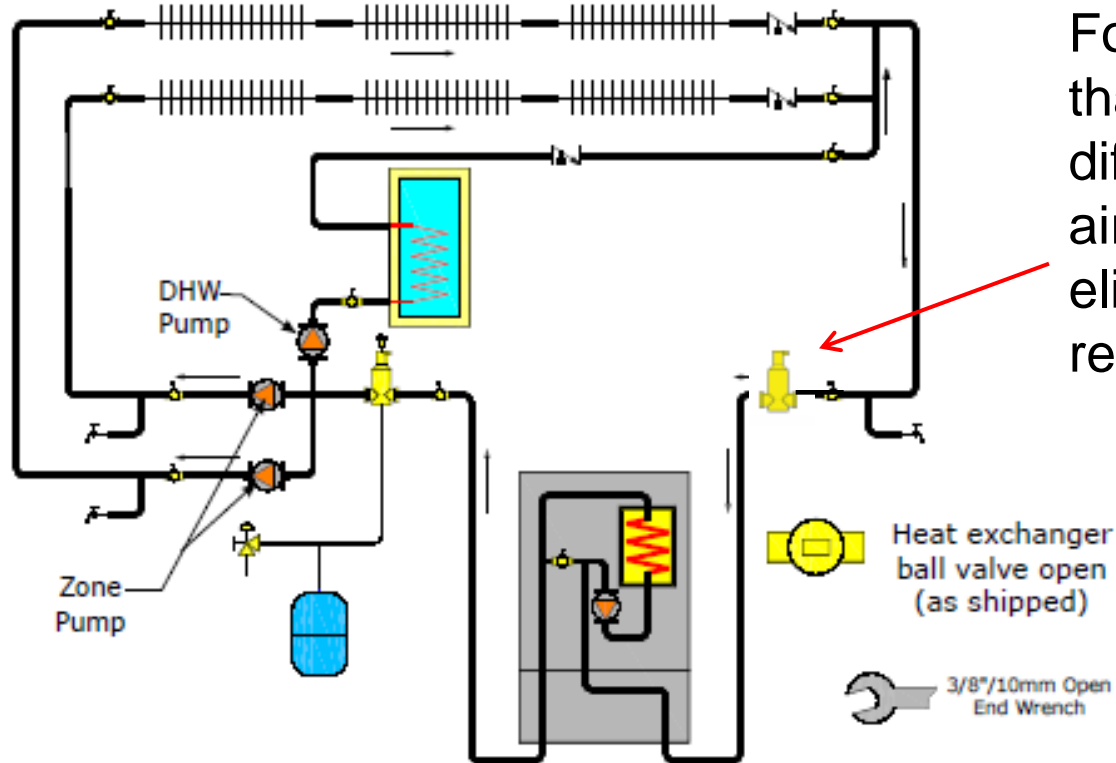
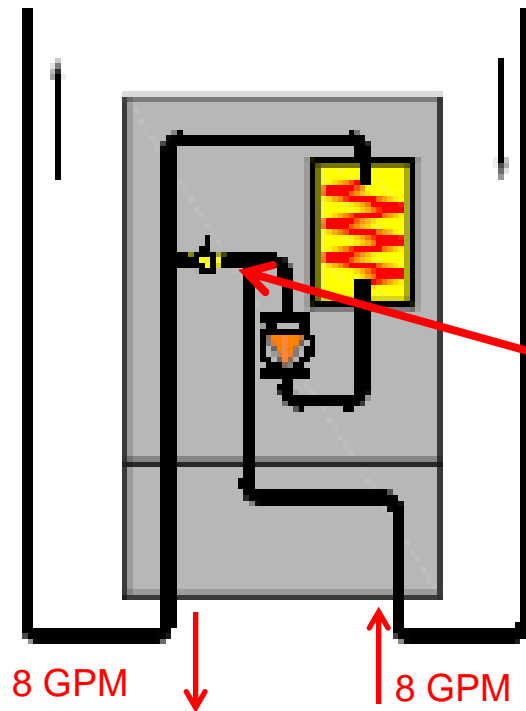

FIGURE 5-6 Single Boiler Two-Pipe Zoned System With Zone Pumps



For installations that have proven difficult to remove air, locate 2nd air eliminator in return to boiler.

SSC Power Purge



- Prior to Firing, close Ball Valve to help move ALL water out of Boiler to purge air.
- Open Ball Valve before Firing

- Low System Flow Rates will cause Boiler to heat quickly
- Cycles frequently on High Limit-Less Efficient
- Harder to get air out of boiler

FIGURE 5-6 Single Boiler Two-Pipe Zoned System With Zone Pumps

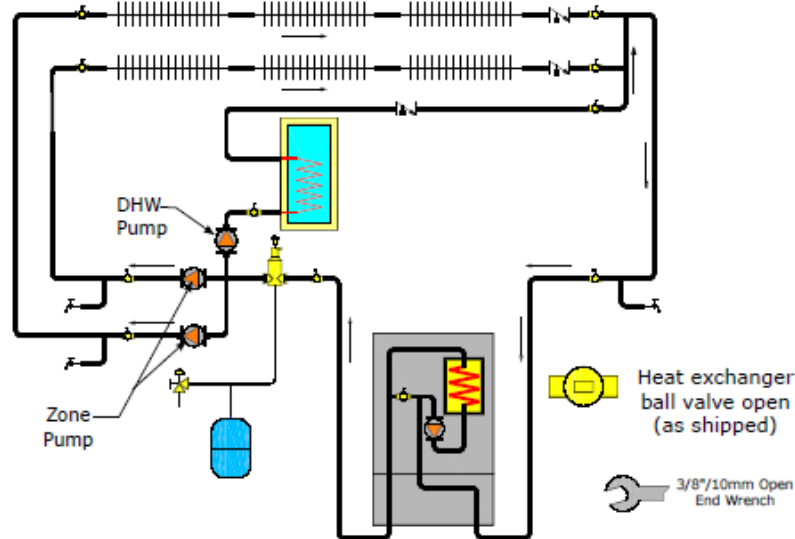

Getting the Air Out

Primary & Secondary Flow Balanced

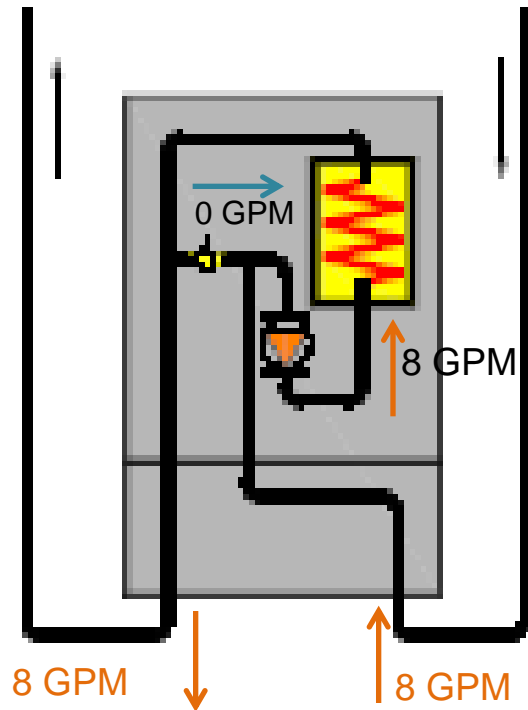

Reduced Flow in Secondary
(One Zone Calling)

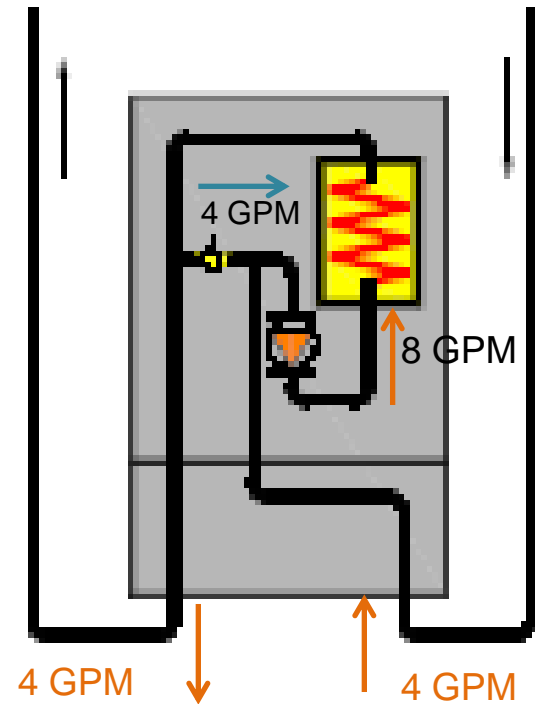

- Treated (Softened) water can reduce circulator capacity by 10-15% !!
- If reduced flow rate is causing noise issues a higher head pump may resolve the problem.

FIGURE 5-6 Single Boiler Two-Pipe Zoned System With Zone Pumps

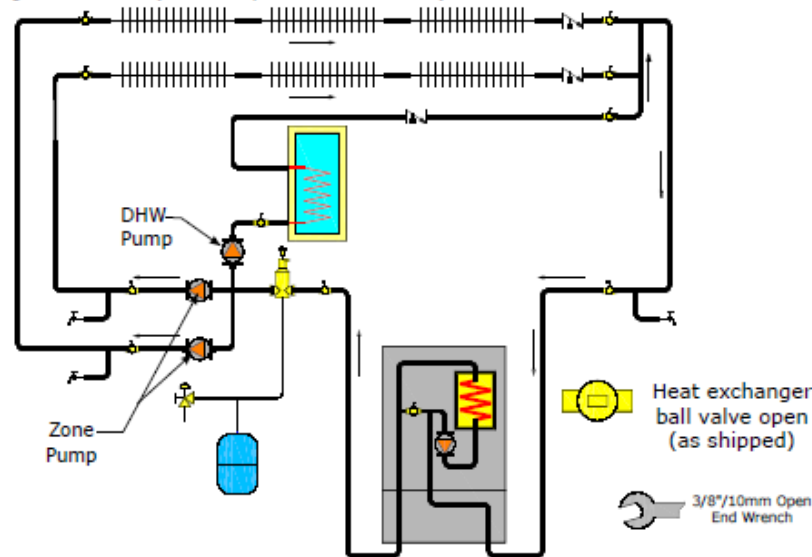



- Water quality can affect system performance
- Dirty brackish water can lower boiling point
- Also makes air removal more difficult



The Point of No Pressure Change

- The Point of no Pressure Change is the one place in the system where the pump cannot affect the overall system pressure.

The Point of No Pressure Change

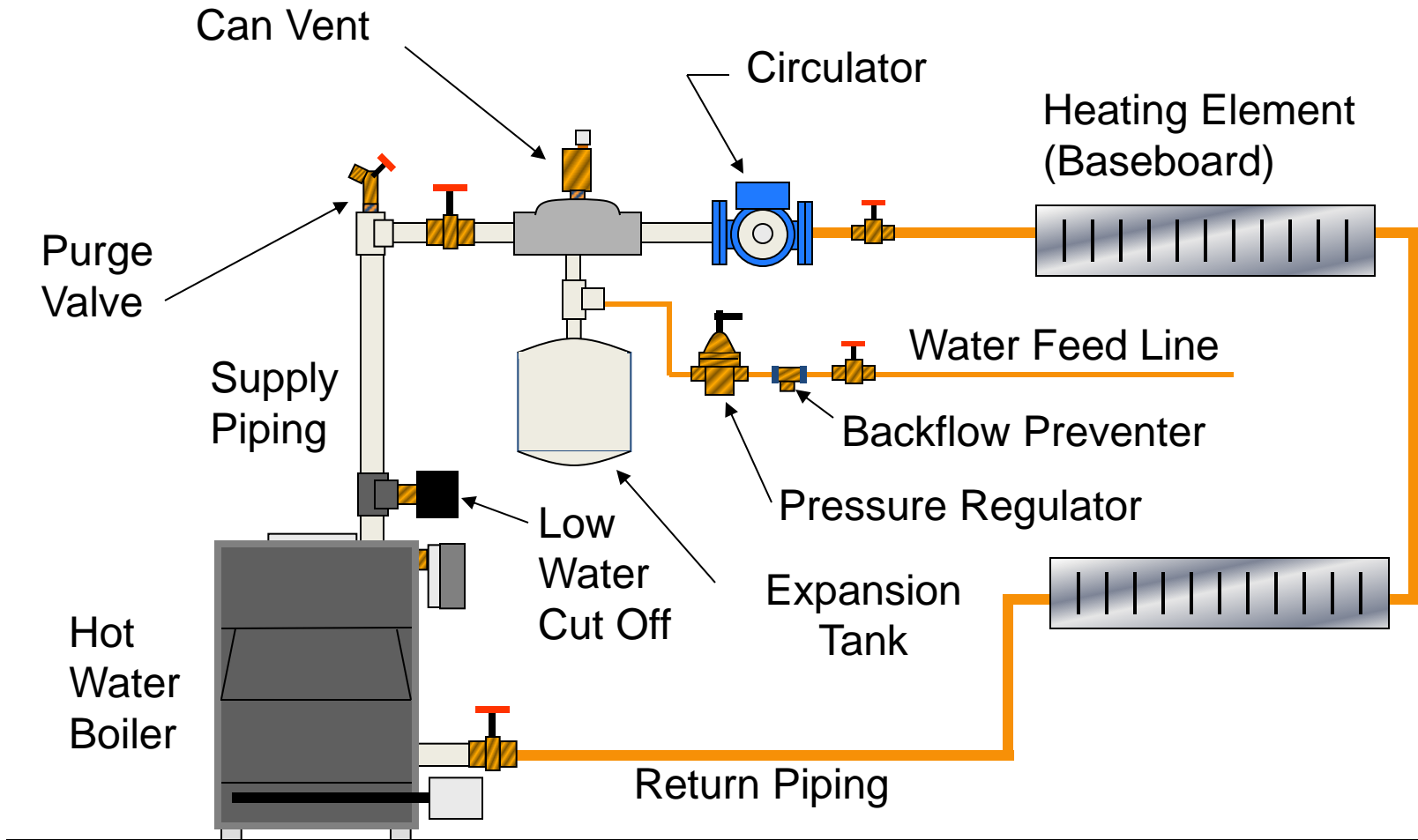

The Point of No Pressure Change

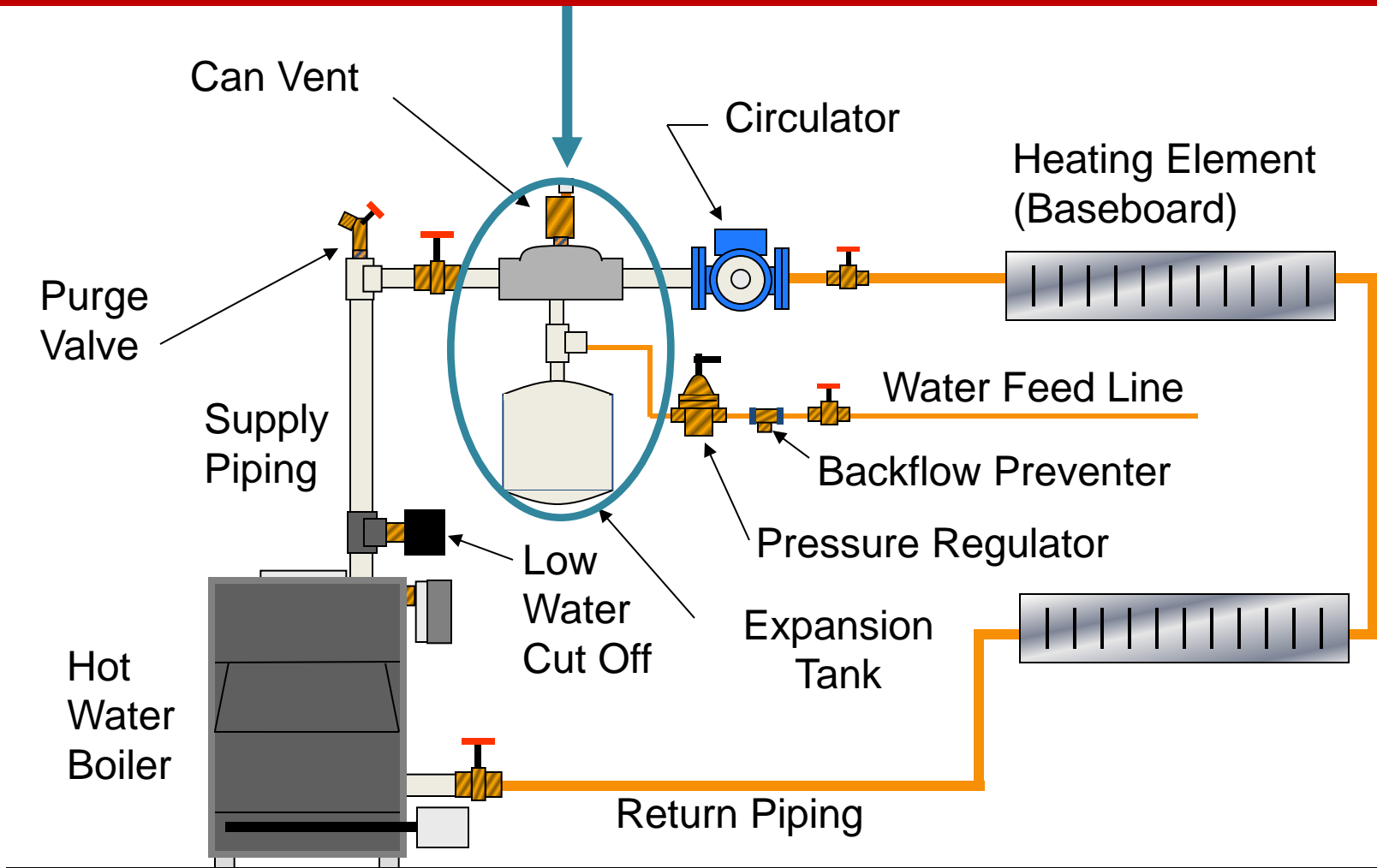

How can pump placement affect system performance?

Supply vs. Return side Pumping

The Point of No Pressure Change

A typical residential circulator will develop about 6psi. In this diagram, all of the pump's differential pressure is on the outlet side.

6 psi differential – water flows

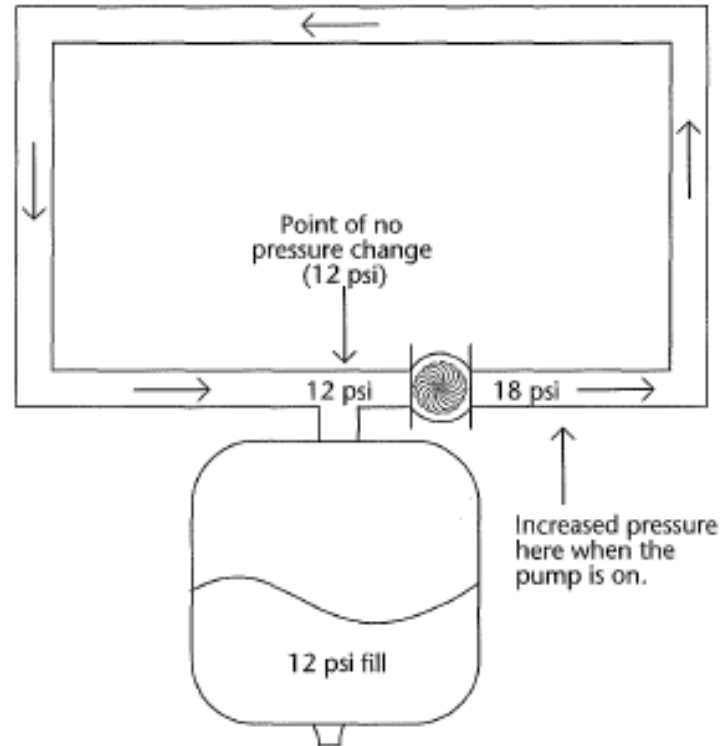

The Point of No Pressure Change

Because the point of no pressure change (the place that must remain at the 12 psi static fill pressure) is now halfway around the system, the pump is showing half of its pressure differential as an increase and the other half as a decrease. You now have a drop of 3 psi at its discharge.

Water flows exactly as it did in the last example because there's still a 6 psi pressure differential across the pump ($15 \text{ psi} - 9 \text{ psi} = 6 \text{ psi}$ differential).

6 psi differential – water flows

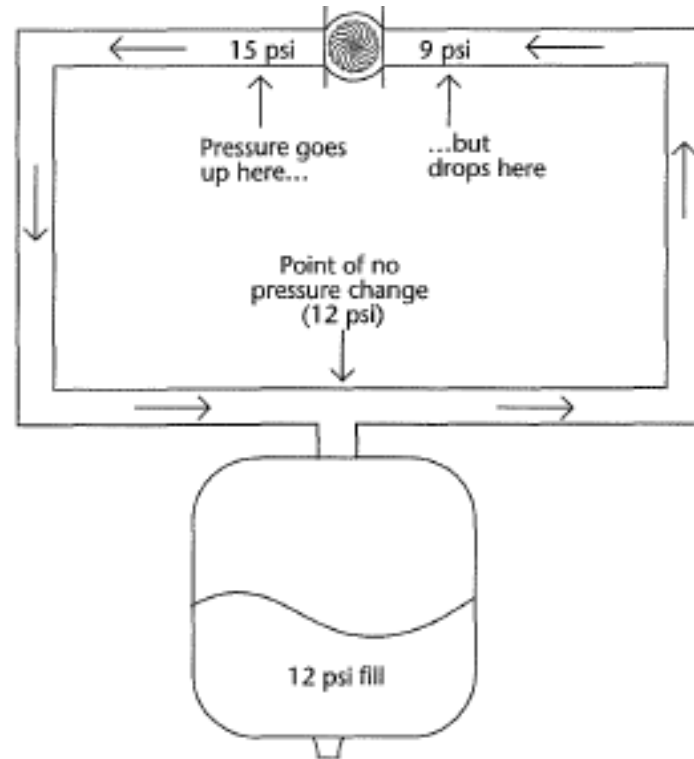

The Point of No Pressure Change

Because the outlet of the pump is right at the point of no pressure change, ALL of the pumps difference is on the inlet side. We still have a 6 psi difference and water flows as before.

6 psi differential – water flows

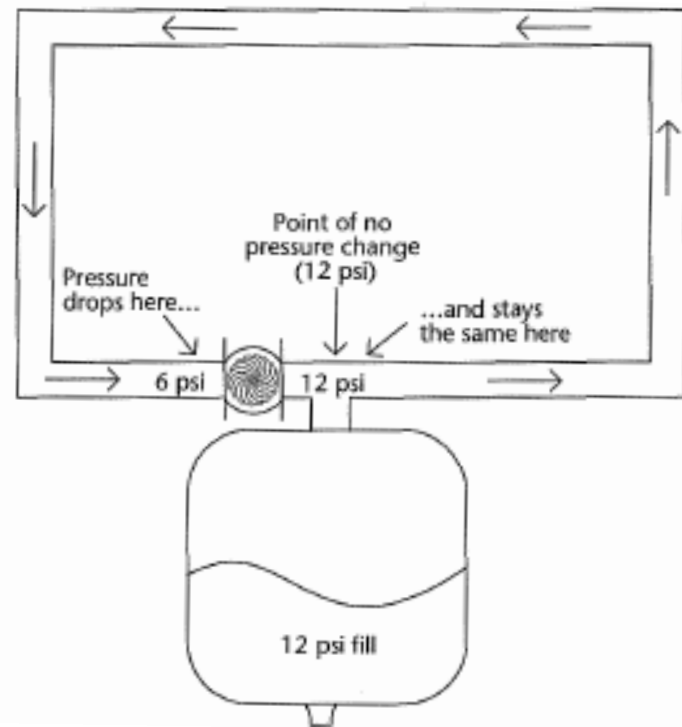

The Point of No Pressure Change

- The Water flowed in all 3 examples
- So why does pump placement matter?

The Point of No Pressure Change

Built-up gas
pops the
cap a bit



Why do the
bubbles
explode out
of the soda?

The Point of No Pressure Change

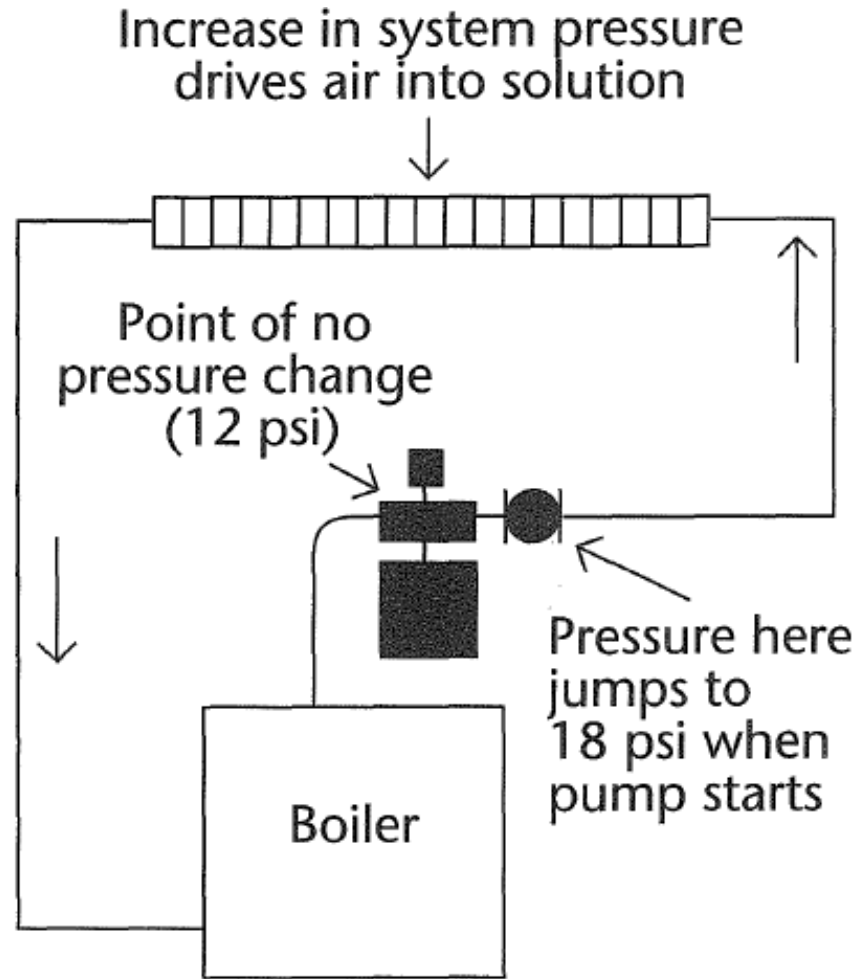

The Point of No Pressure Change

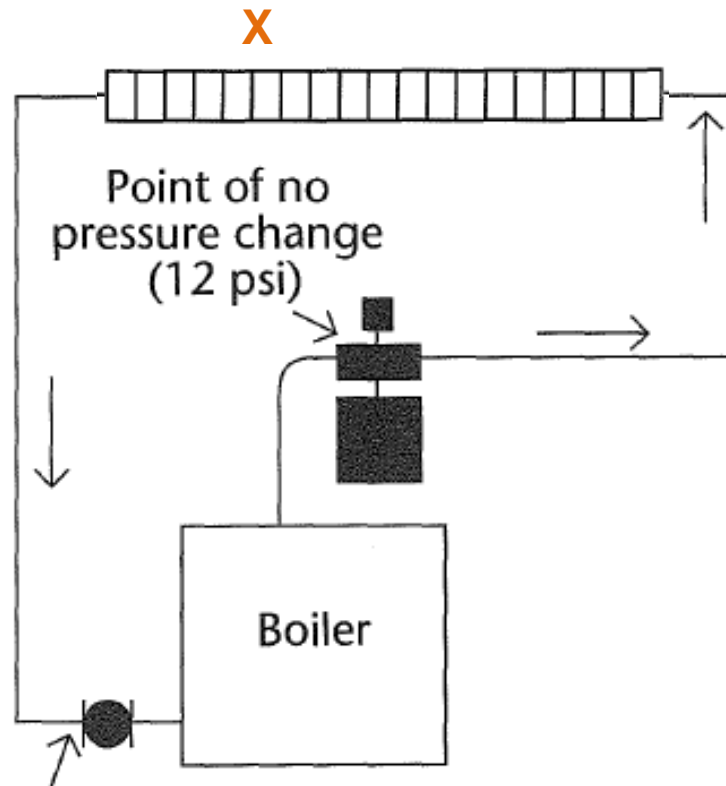

With pump located on return what happens to the pressure at "X" when the pump starts?

The Point of No Pressure Change

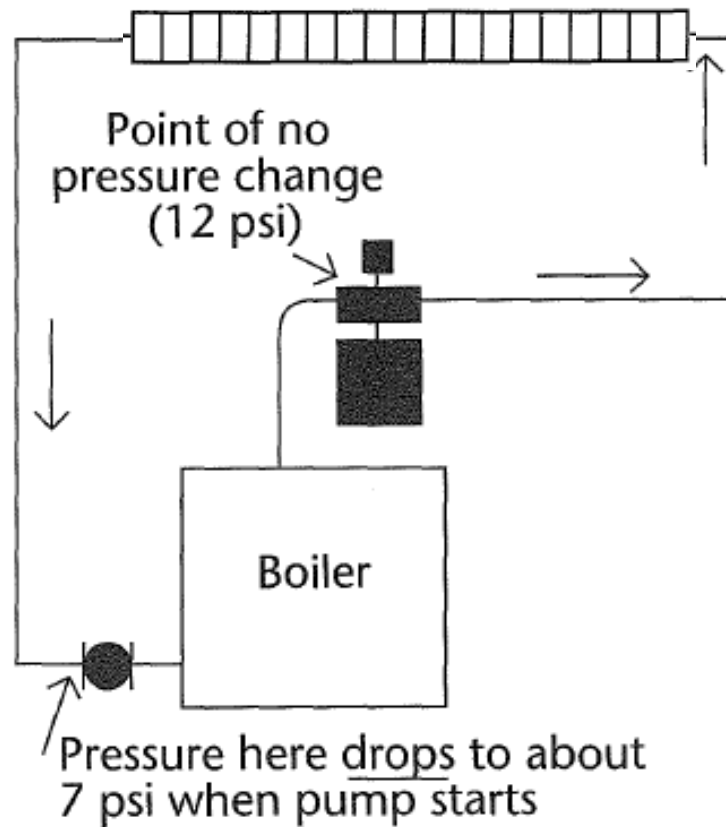

The Point of No Pressure Change

Drop in system pressure releases dissolved air and makes the bubbles larger!

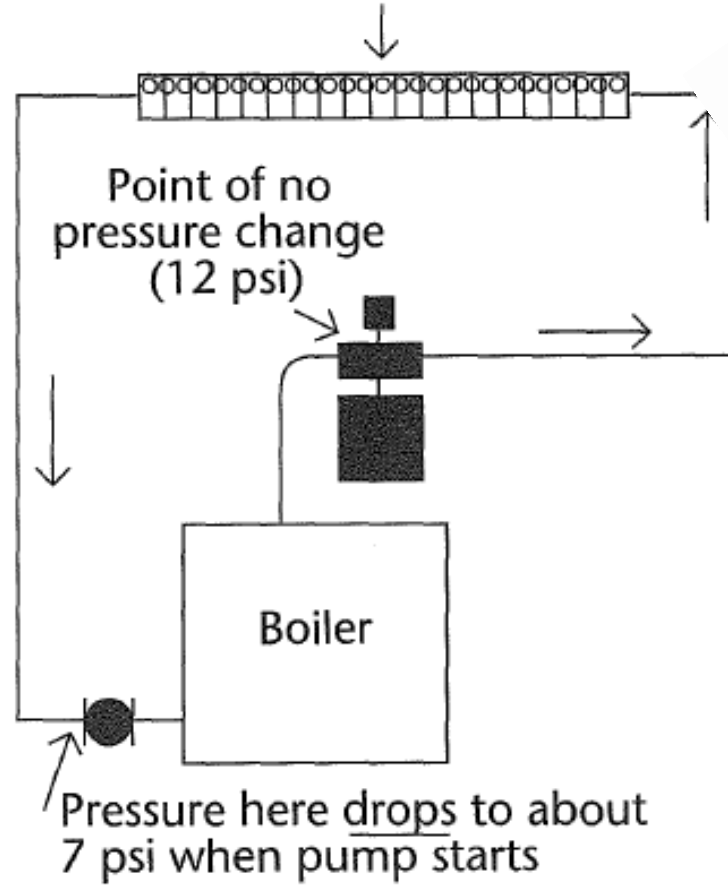

Increase the Boiling Point

- If existing system is contributing to air removal difficulties raise the boiling point.
- Increase system pressure to 20 psi.
- Remember to pump the Expansion tank!
- If higher pressure needed change Boiler relief to 50 psi and increase system pressure further.
- Remember to pump the Expansion tank!

Adjust Expansion Tank Pressure

Normal Tank Operation

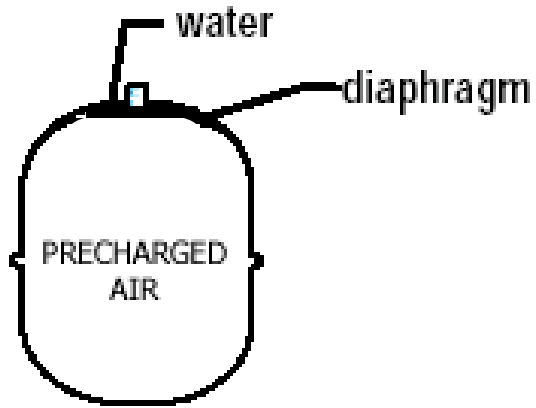

System Off

System Pressure=12

Tank Pressure=12

Adjust Expansion Tank Pressure

Normal Tank Operation

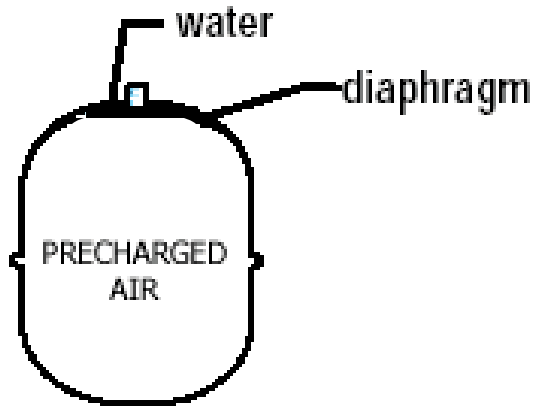

System Off

System Pressure=12

Tank Pressure=12

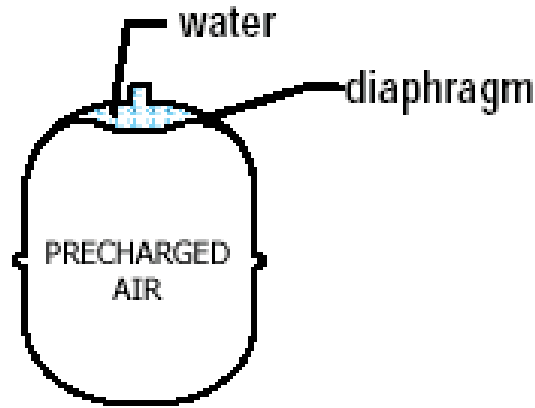

System **On**

System Pressure=14

Tank Pressure=14

Adjust Expansion Tank Pressure

Normal Tank Operation

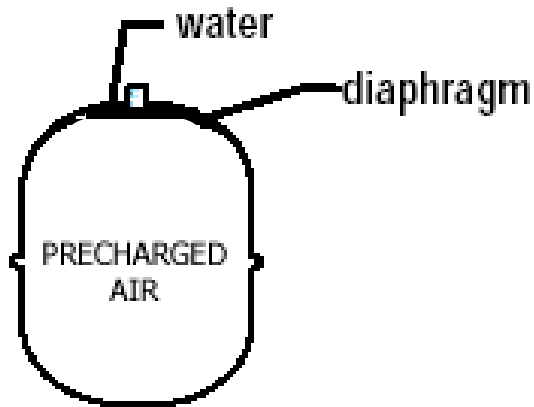

System Off

System Pressure=12

Tank Pressure=12

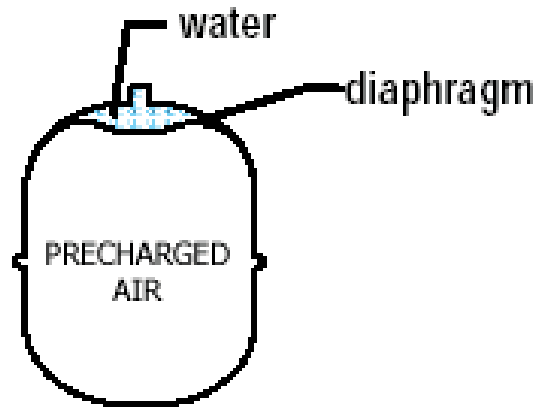

System **On**

System Pressure=14

Tank Pressure=14

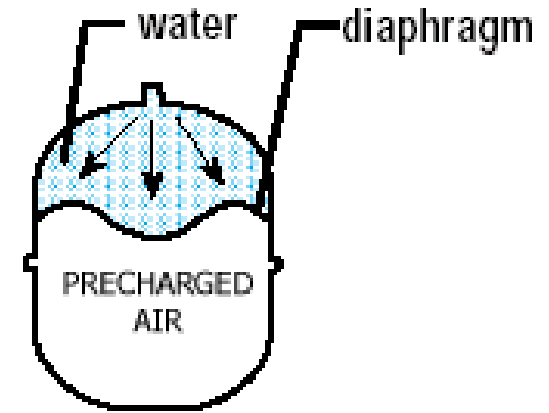

System **On**

System Pressure=18

Tank Pressure=18

Adjust Expansion Tank Pressure

What happens if I don't Pump Up my Tank?

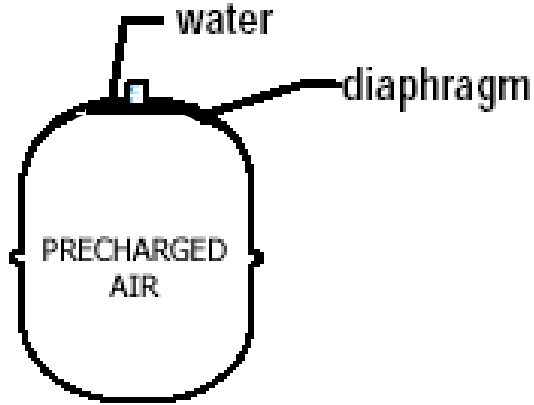

System Off

System Pressure=12

Tank Pressure=12

Adjust Expansion Tank Pressure

What happens if I don't Pump Up my Tank?

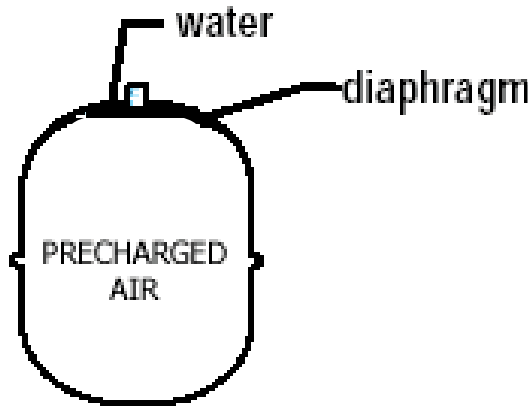

System Off

System Pressure=12

Tank Pressure=12

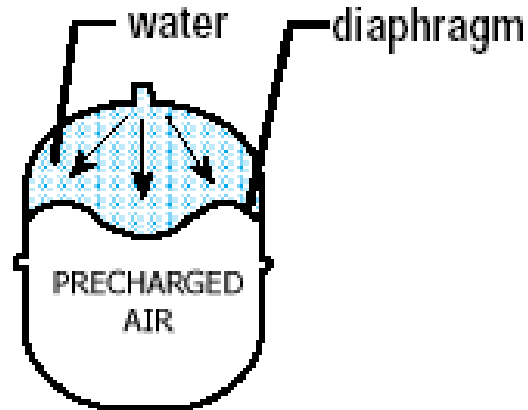

System Off

System Pressure Increased to 20

**(Tank Fills until air is
Compressed to match)**

Tank Pressure=20

Adjust Expansion Tank Pressure

What happens if I don't Pump Up my Tank?

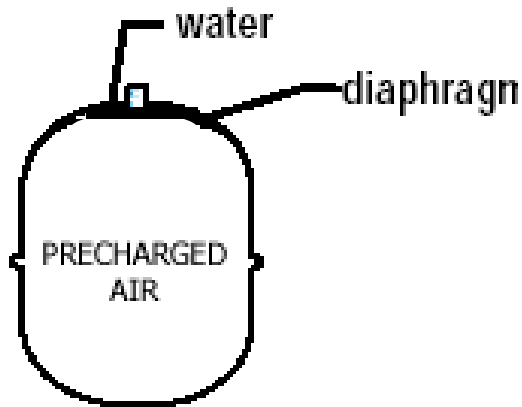

System Off
System Pressure=12
Tank Pressure=12

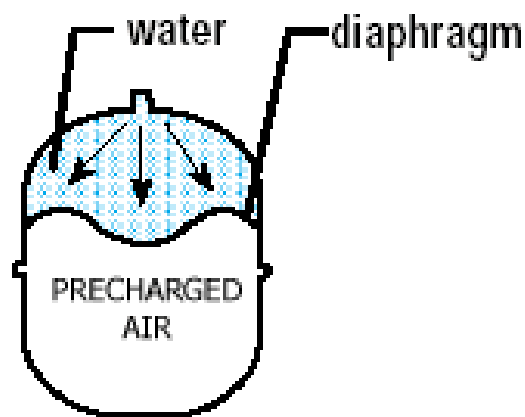

System Off
System Pressure=20
**(Tank Fills until air is
Compressed to
match)**
Tank Pressure=20

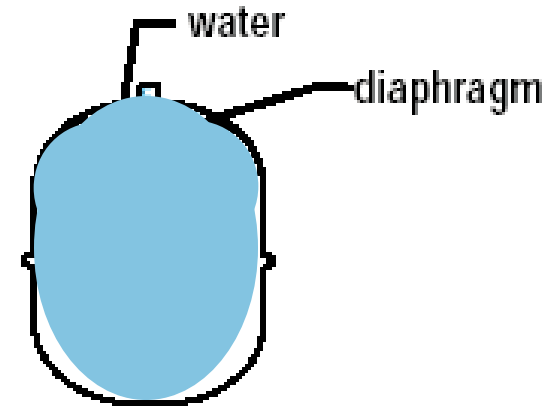

System **On**- Pressure
Increases due to
Expansion
System Pressure= 
Tank =FULL!

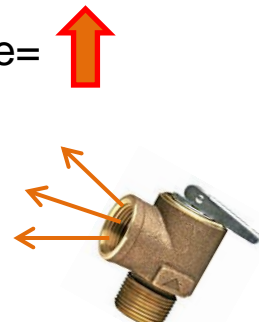
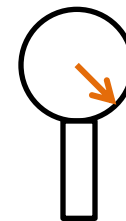

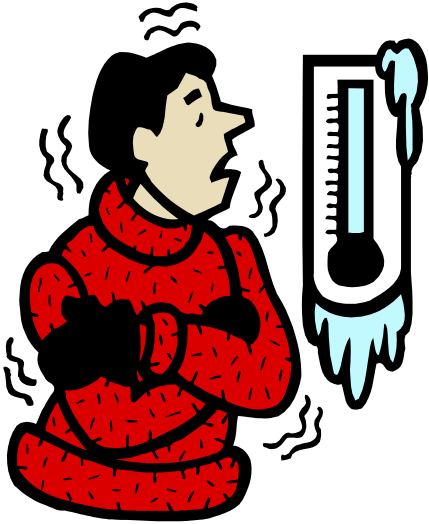

- Antifreeze is more viscous. Pump capacity reduced.
- Thermal transfer capability reduced 17% at 50-50 strength.
- Only use what's necessary.
- Use tester to determine proper level.

- 15 Year ECR Limited Warranty
- One Year all other parts



FIRST YEAR HEAT EXCHANGER ADDITIONAL COVERAGE

Effective June 1, 2011

The SSC boiler utilizes our most innovative heat exchanger design that provides industry leading efficiency and reliability. It consists of a wide diameter stainless steel tube with laser welded heat transfer fins that provide for the greatest heat transfer. The SSC heat exchanger is designed to endure the most challenging applications and guard against compromised water conditions that cause other boilers





ECR *international*
EST. 1928
A Family of Heating & Cooling Brands.

1-800-325-5479

Or

1-800-253-7900

[Training & Videos](#)[Warranty Registration](#)[Rebates & Special Offers](#)[Dealer Portal](#)[Products](#)[Documents](#)[FAQs](#)[Find A Dealer](#)[News](#)[Contact](#)

There are some things you can always depend on...

Utica Boilers has been a trusted supplier of gas and oil-fired boilers for residential and commercial buildings since 1928. Contractors and homeowners alike choose Utica Boilers as their preferred supplier because of our high efficiencies, easy maintenance and installation features, and limited lifetime warranties.

Our line of products are designed, tested, and assembled to ensure that our customers get the very best in home heating comfort and value. The complete selection of gas and oil-fired products only use superior parts and has earned a reputation for exceptional quality, performance, and dependability since its inception. Our testing standards are second to none and are supplemented by a computerized process that tracks components to finished goods. Utica's highly trained and skilled workforce ensures every customer that our products and service are among the best in the industry.

Utica products offer:

- Innovative, dependable designs made right here in America
- Solid reliability
- Highest quality parts
- Best-in-class warranties
- Responsive and adaptive service professionals

SSC STAINLESS STEEL CONDENSING Wall hung modulating condensing boiler



Most Efficient

Thank You