



SSV

Technical Training

Gas-Fired, Wall Hung Modulating Condensing Boiler



Co-Founder
Earle C. Reed



Capacities BTUH	50,000	75,000	100,000	150,000	200,000
Modulation with 5 to 1 turndown	50,000 ----- 10,000	75,000 ----- 15,000	100,000 ----- 20,000	150,000 ----- 30,000	200,000 ----- 40,000
Nat or LP	LP conversion kits are available as an option				
AFUE	95	95	95	95	95
Water Connections	3/4" Copper stub	3/4" Copper stub	3/4" Copper stub	1" Copper stub	1" Copper stub





Model Size	50,000 75,000 100,000	150,000 200,000
Width (A)	20"	23"
Height (B)	27.75"	37.75"
Depth (C)	14.75"	16.3"
Boiler Weights	<u>75 lbs.</u>	<u>127 lbs.</u>



ARGUS™ Control
EASY TO PROGRAM
EASY TO UNDERSTAND

Same Control on 50-200 models!



- **The ARGUS Control:**
- **Plain text display – no codes**
- **Displays boiler status and water temperature**
- **Records run time & cycling for Heating and Domestic Hot water**
- **Has built in Domestic Hot Water Priority**
- **Functions as Multiple Boiler Controller-up to 16 boilers!**
- **Built in Boost function**
- **Monitors the temperature of the Supply water, Return water, and Outdoor Air to continuously modulate the combustion process. This insures the boiler only burns the fuel necessary for the heat load of the home.**

- **Wiring Harness**
- **Eliminated Low Water Cut Off**
- **Eliminated Internal Trap**
- **Smaller Cabinet**
- **One Piece Jacket**
- **Jacket removal Clip**

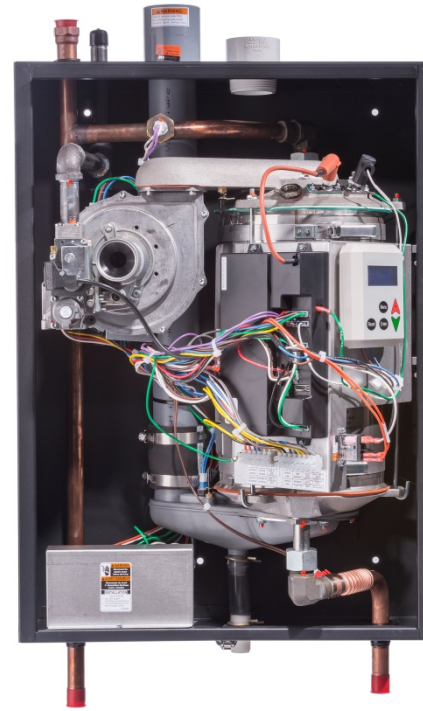

- **Vertical Stainless Steel Coil Heat Exchanger**
- **Specialized flue collector designs**
- **Argus vision control**
- **Internal gas drip leg**
- **Copper stub Connections**
- **Boiler powers CH & DHW & Primary Loop Pump**
- **Smaller Cabinet**
- **One Piece Jacket**
- **Jacket removal Clip**

- Vertical Coil – Self Cleaning

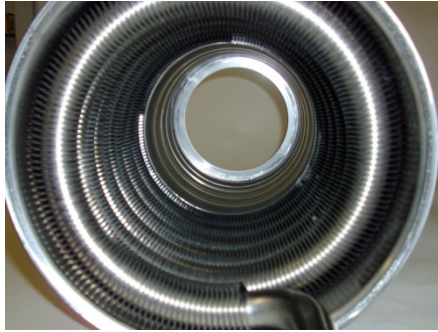

- Stainless Steel Coil 316L with 444 fins that are laser welded to the coil.

- ASME “H” stamp with 150 MAWP

- Exclusive to ECR. Developed in our research facility located in Utica, NY

Benefits

Waterways are wide and smooth with a helix coil that expands and contracts to inhibit hard water scaling. The vertical design coil prevents debris from settling in the heat exchanger. Condensate flowing over the fins continually “washes” the combustion side

The stainless steel is resistant to the effects of acidic condensate. The laser welding process ensures the highest level of heat transfer and efficiency

H Stamped, ASME heat exchanger designed, assembled and independently audited in our Utica NY facility.

Heat Exchanger

316L stainless steel tubing has 444 fins laser welded onto the tubing. 444 fins are used due to their high heat transfer and high corrosion resistance in the combustion area.

Tubing Diameter

The larger diameter tubing and round shape optimize water flow through the heat exchanger.

Positioning / Self Cleaning

The vertical positioning of the coil heat exchanger and open fin spacing allows the heat exchanger to drain off any combustion particles. The natural flexing of the coil during operation reduces scale buildup

Self cleaning – both water and flue gas sides



SSV Coil



VLT round shape with a larger diameter coil for better water flow and reduced scaling



Vertically positioned to drain away any debris and scale - self cleaning. Open flueways between the coils.

SSV Coil



**Vertical Coil can't trap
byproducts of combustion
or water scale.**

Less Maintenance!



SSV Coil

Water Tube – Single piece coil

Self Cleaning

Flue Gas Side – **Yes**

Water Side – **Yes** - water flow velocity is maintained preventing debris from settling. The natural flexing of the coil (during operation) reduces scale buildup

15 year HX warranty

5:1 turndown

95% AFUE

Vertically Positioned - yes
Self Cleaning – (see below)
Stainless Construction – yes

Multiple Welds



Competition



Fire Tube – multiple tubes with welded connections
potential stress and leak points

Self Cleaning

Flue Gas Side – **Yes**

Water Side – Water flow velocity is reduced
allowing debris to settle inside the
heat exchanger

10 year HX warranty

3.7:1 or 5:1 turndown – depending on manufacture

95% AFUE

SSV Coil

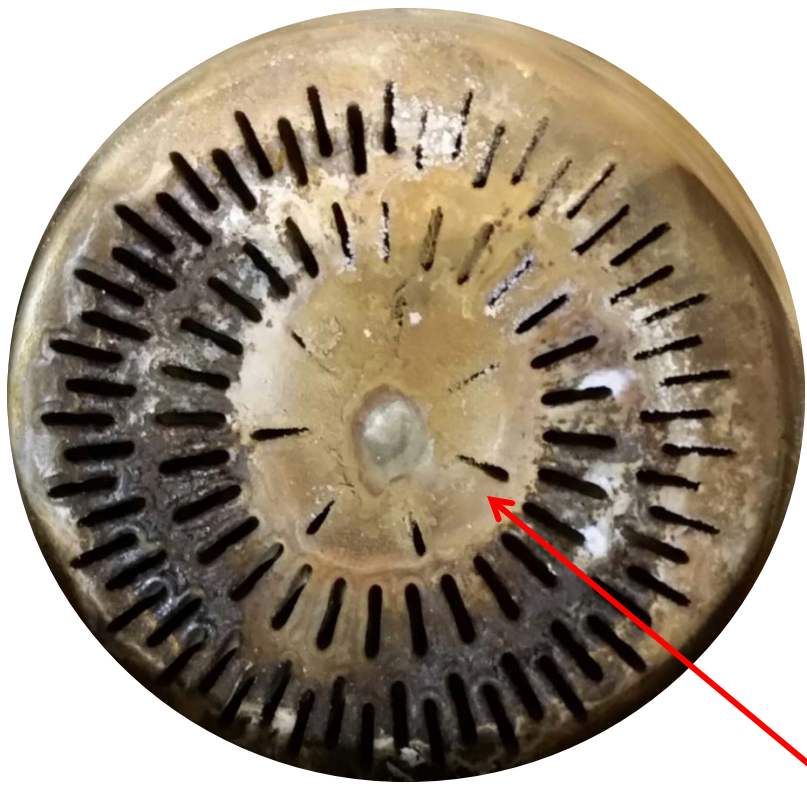

**Vertical Coil can't trap
byproducts of combustion**

Less Maintenance!



SSV Coil



Vertical Coil can't trap water scale.

Less Maintenance!



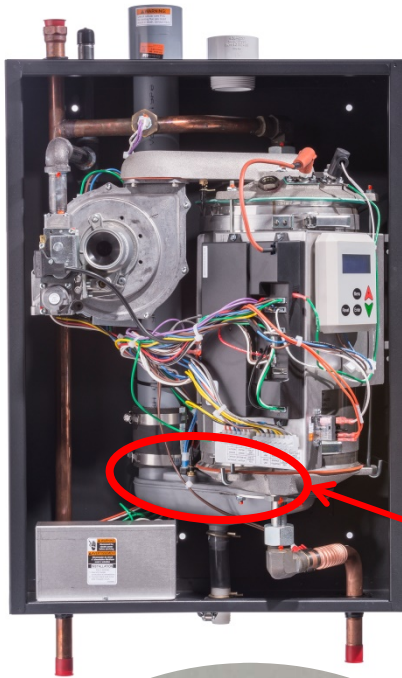

Flue Collector: High temperature non-metallic

- Polypropylene
- Excellent corrosion resistance in highly acidic critical area
- Condensate will not pool on metal surfaces of the heat exchanger



Ultrasonic Weld



**Listed with
Polypropylene as a
venting option**

- Worgas™ designed gas burner for the unit
- Natural / propane
- Easy removal for field inspection
- Easy removal for maintenance to heat exchanger

Note: Burner is keyed to heat exchanger. Line up notch in heat exchanger casting.



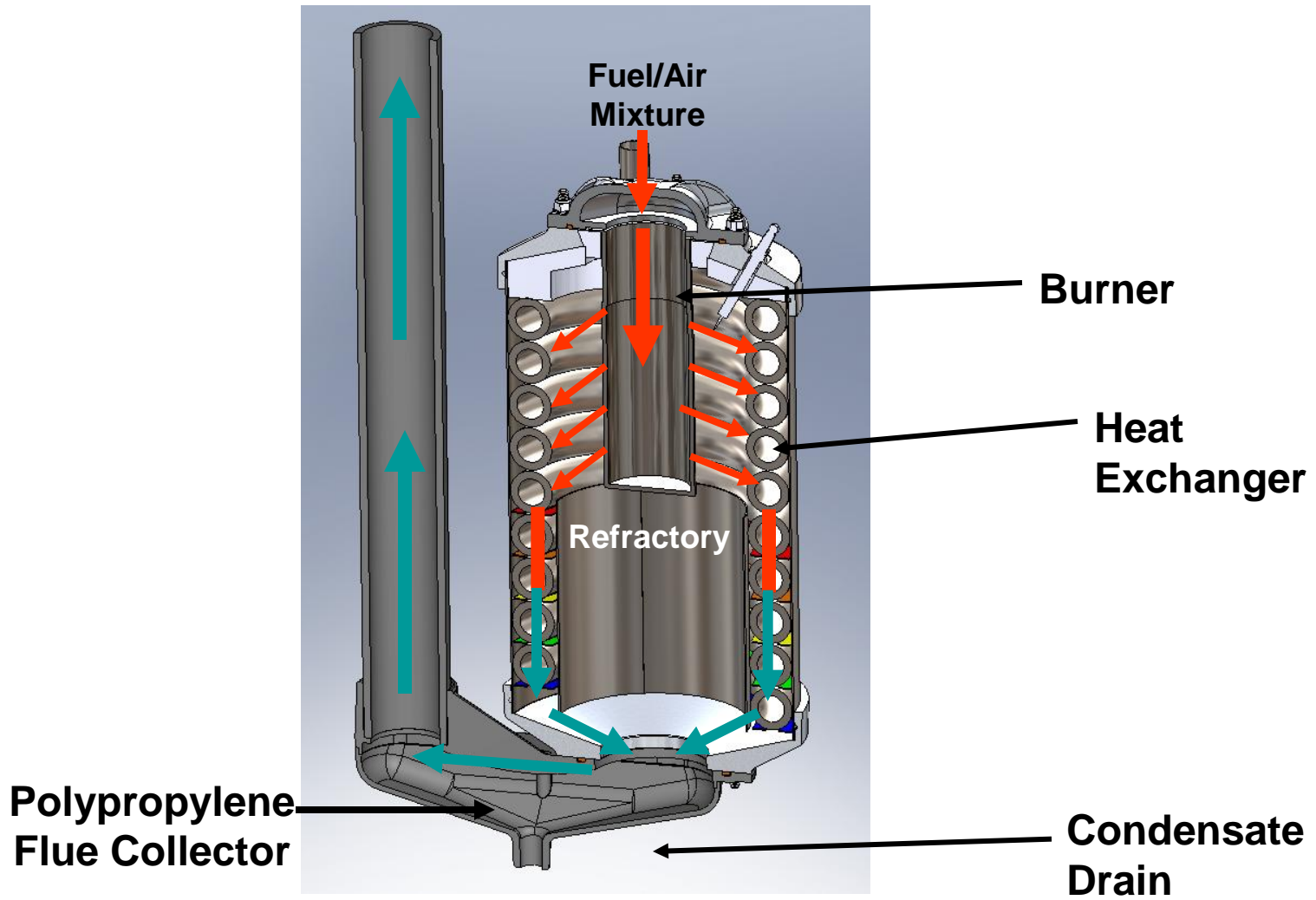

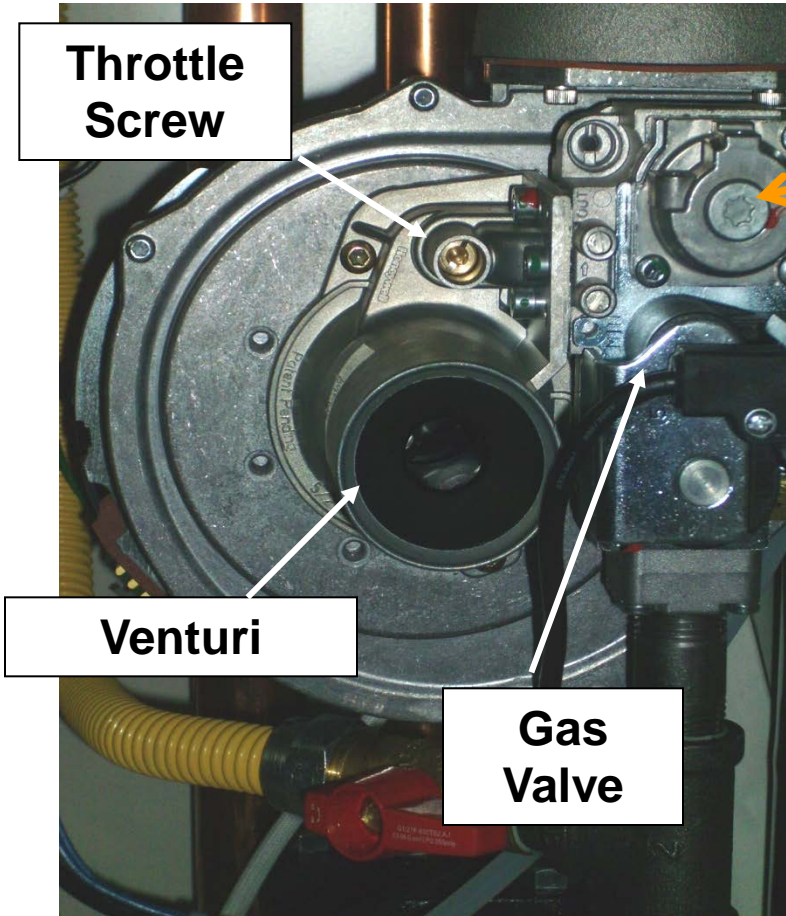

Don't touch offset screw
Will void valve's calibration

- 120 volt gas valve system
- Venturi system takes air from within the sealed cabinet
- Adjust throttle screw for proper gas / air CO² setting

- Preassembled external condensate trap with air break
- Fill trap with water prior to start of boiler.
- Contractor is required to run a drain off boiler.

FIGURE 6-18 Condensate Drain

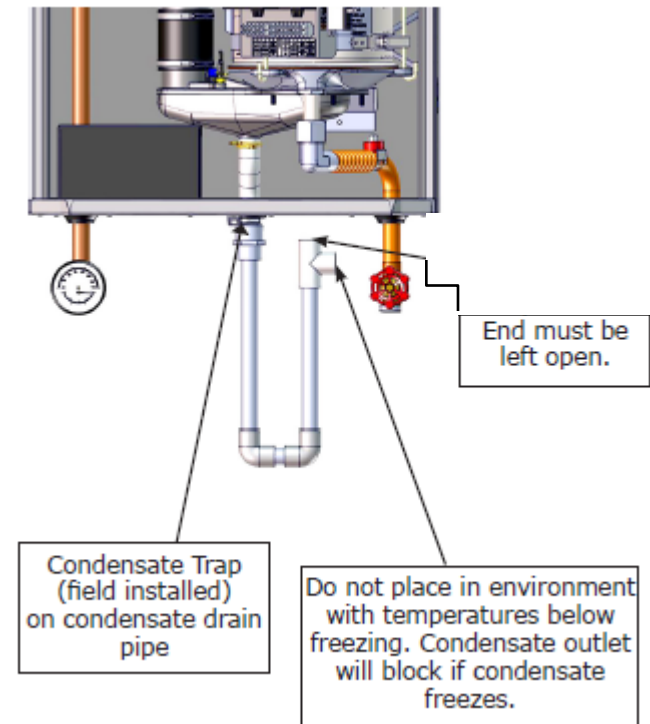



Boiler Clearances		
Dimension	Combustible Materials (1)	Service (1) (2)
Model	050/075/100/ 150/200	050/075/100/ 150/200
Top	0" (0 cm)	14" (36 cm)
Left Side	0" (0 cm)	0" (0 cm)
Right Side	0" (0 cm)	0" (0 cm)
Front	0" (0 cm)	6" (16 cm)
Back	0" (0 cm)	0" (0 cm)
Bottom	0" (0 cm)	12" (38)
Combustion Air/Vent Piping	0" (0 cm)	6" (16 cm)
Hot Water Piping	1/2" (1.3 cm)	6" (16 cm)
(1) Required distances measured from boiler.		
(2) Service, proper operation clearance recommendation.		



- Access to outdoors to meet minimum and maximum pipe lengths
- Disposal of condensate
- Drainage of water or anti-freeze during service or from safety relief valve piping
- Access to system water, gas piping and electrical service
- Ambient room location above 32°F
- Approved for installation in a closet
- Protect boiler from any external water or moisture that could damage the electrical or combustion controls

Wall Mounting Bracket & Hardware Included with boiler

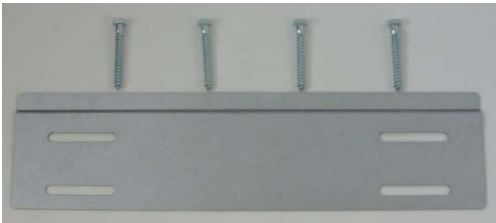

Optional Floor Stand Features Include:

- Powder Coated Black Paint with a textured finish to match the boiler back panel. The paint process provides a durable rust resistant finish.
- One size floor stand fits the entire SSV condensing family from 50 through 200 mbh.
- The stand is shipped in a knockdown configuration for ease of handling and transport. The stand can be quickly assembled at the jobsite in just a few minutes.

Note: For Multiple Boiler Applications - Boilers can be placed side by side or back to back

- Bottom Supply and Return :
 - 3/4" Copper Stub 50-75-100
 - 1" Copper Stub 150-200
- Condensate Drain – 3/4" NPT
- Combustion Air & Vent:
 - 2" PVC 50-75-100
 - 3" PVC 150-200
- 3/4" NPT Stub out on top for field installation of Safety Relief (included with Boiler)

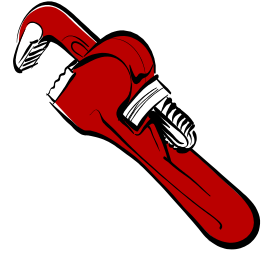

Backup wrench when tightening fittings

Top View

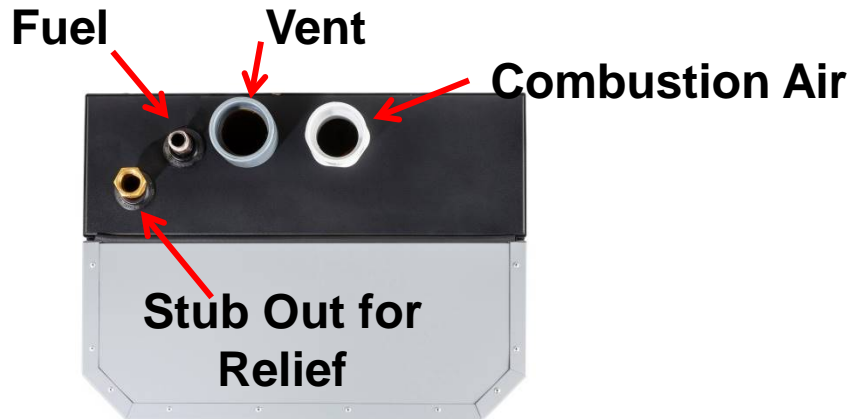

Bottom View

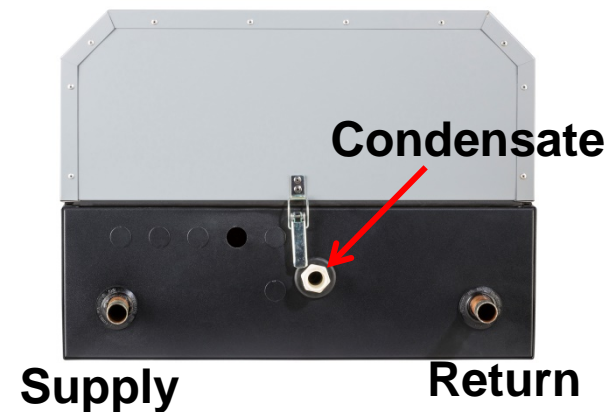
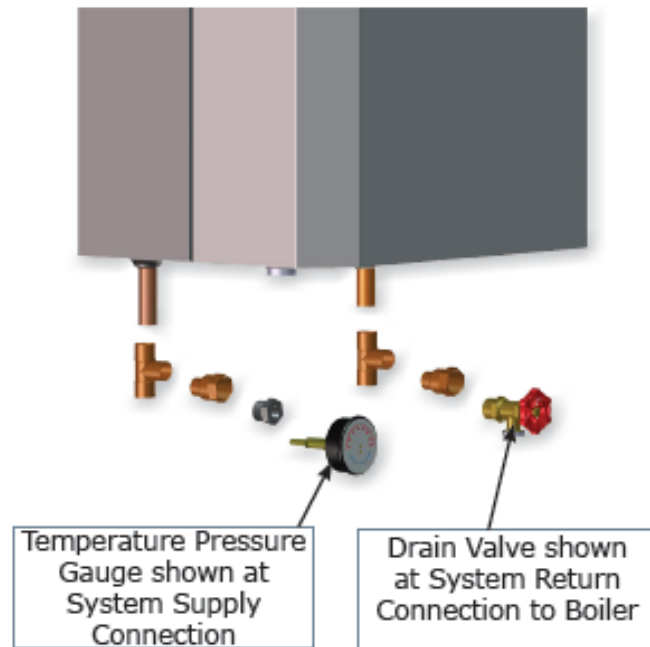

FIGURE 5-3 Temperature Pressure Gauge and Drain Valve Installations



Included with the boiler is a trim kit!

- Gas piping needs to be in accordance with all national and local codes
- Sediment Leg built inside boiler
- Always check gas piping and connections for leaks



1/2" NPT Gas Connection 50/75/100

3/4" NPT Gas Connection 150/200

Use a backup wrench when tightening

FIGURE 7-2 Manual Gas Shutoff Valve - Outside Boiler Jacket (view from top rear of boiler)

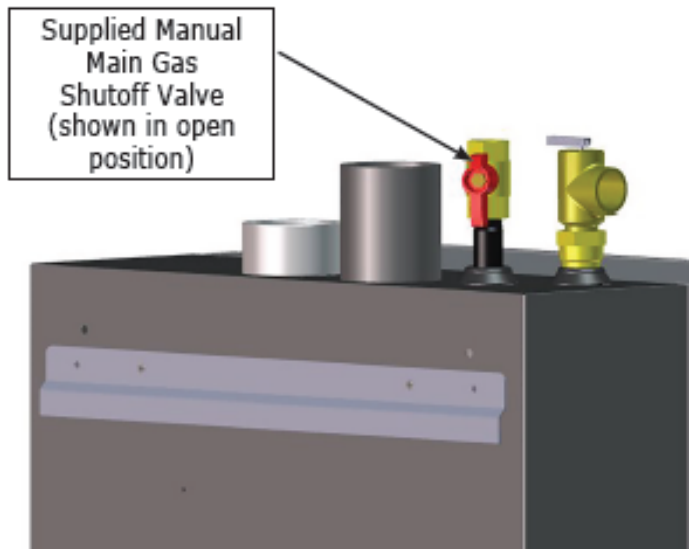

Rated up to 150 MAWP

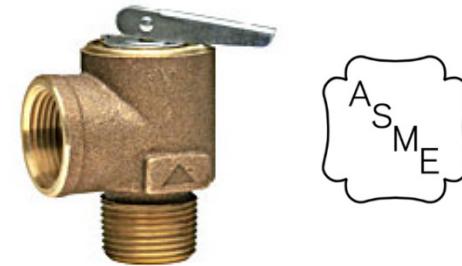

- Factory supplied 30 psig relief valve
- Install $\frac{3}{4}$ " or larger discharge pipe to floor
- Install relief valve with spindle in vertical position only
- Do not install shutoff valve between boiler and safety relief valve
- Field Installed - pipe relief valve to within 6" of floor

Gas Supply Pressure				
Capacities BTUH	Natural Gas		Propane	
	Min.	Max.	Min.	Max.
50,000 - 200,000	*3.0" w.c. (0.7kPa)	13.5" w.c. (3.3 kPa)	5.0" w.c. (1.2 kPa)	13.5" w.c. (3.4 kPa)

*Minimum gas pressure requirement of 3" w.c. – excellent for metropolitan areas with low gas pressure from the utility.

- All boilers shipped as Nat Gas. LP Kit available.
- Propane orifice conversion from natural gas in less than 5 minutes.
- Orifice to be installed for propane gas fired units
- Propane gas supply inlet pressures: 5" w.c. minimum, 13.5" w.c. maximum



Propane orifice
location 50-200

Combustion Air and Vent Pipe Equivalent Length				
Model	2" Pipe		3" Pipe	
	050	075/100	075/100	150/200
Min.	6 ft. (1.8 m)	6 ft. (1.8 m)	6 ft. (1.8 m)	6 ft. (1.8 m)
Max.	100 ft. (30.5 m)	50 ft. (15.2 m)	100 ft. (30.5 m)	100 ft. (30.5 m)

1 - 90° elbow = 5 ft. (1.6 m)
1 - 45° elbow = 3.5 ft. (1.1 m)
1 - 2" x 3" adapter = 0 ft. (0 m)
Note: Concentric Vent Kit = 5 ft. (1.6 m) equivalent length
 i.e.: Boiler can be installed on outside wall and vented with 1 - 90° elbow and 1 ft. (0.30m) of vent pipe.

- **PVC**
- **CPVC**
- **ABS**
- **Polypropylene**

**** Make sure to use appropriate glue for proper vent pipe**

Table 4 – Combustion air and vent pipe fittings must conform with the following:		
Item	Material	Standards
Vent Pipe and Fittings	PVC schedule 40	ANSI/ASTM D1785
	PVC – DWV	ANSI/ASTM D2665
	CPVC schedule 40	ANSI/ASTM D1784/F441
	SDR-21 & SDR-26 PVC	ANSI/ASTM D2241
	ABS-DWV	ANSI/ASTM D2661
	Schedule 40ABS	ANSI/ASTM F627
	PP (Polypropylene) Pipe and Components	UL 1738 ULC S636-08
Pipe Cement / Primer	PVC	ANSI/ASTM D2564
	CPVC	ANSI/ASTM F493
	Schedule 40 ABS	ANSI/ASTM D2235
<ul style="list-style-type: none"> • IPEX is approved vent manufacturer in Canada listed to ULC-S636. • IPEX System 636 Cements and Primers are approved in Canada listed to ULC-S636 		
Use of cellular core PVC (ASTM F891), cellular core CPVC, or Radel®, (Polyphenolsulfone) in venting systems shall be prohibited.		

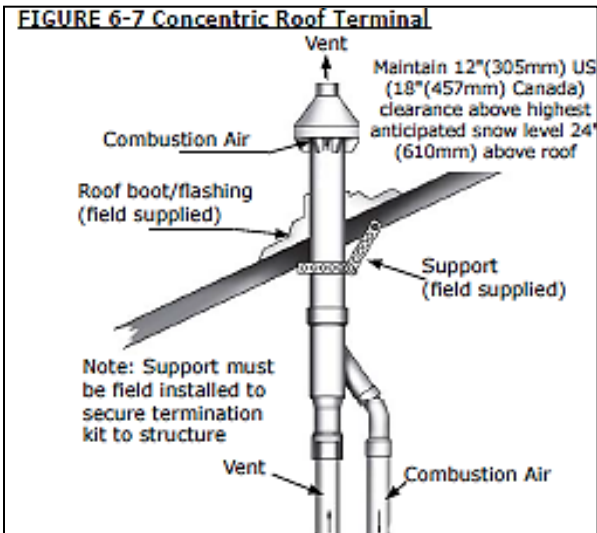

Roof w/ Concentric combustion air

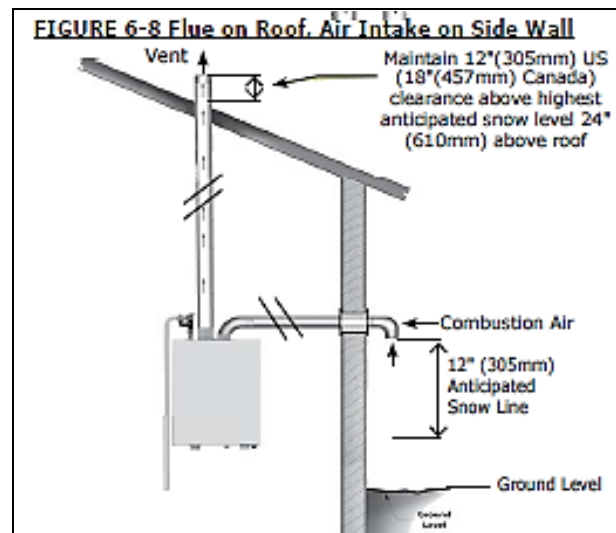

Roof w/ sidewall combustion air

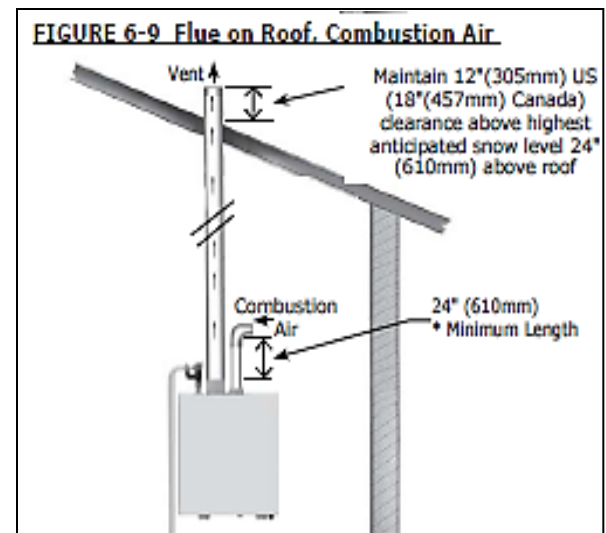

Roof w/ inside combustion air

FIGURE 6-10 Flue on Sidewall, Combustion Air on Roof

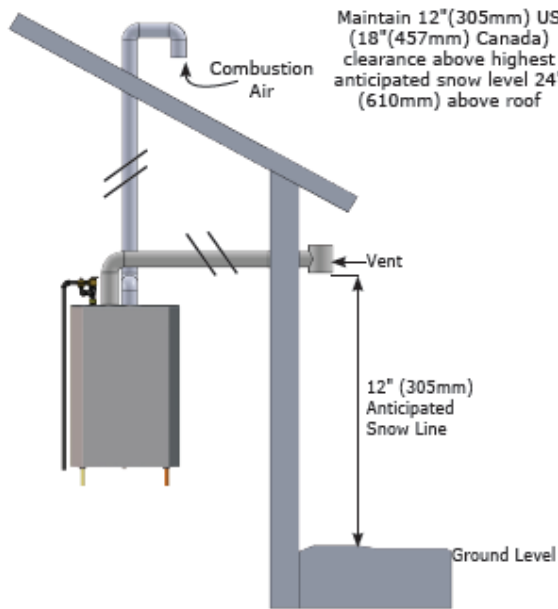

Sidewall vent w/
combustion air on roof

FIGURE 6-11 Flue on Sidewall, Inside Combustion Air

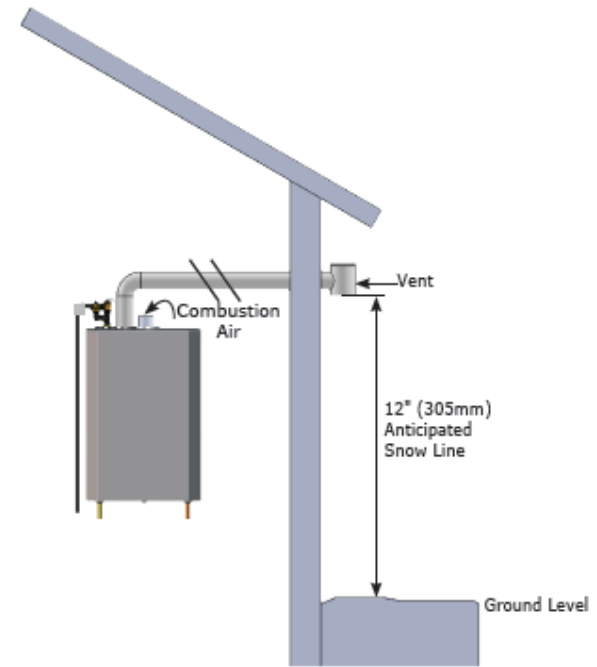

Sidewall vent w/
inside combustion air

FIGURE 6-1 Two Pipe Roof Vent

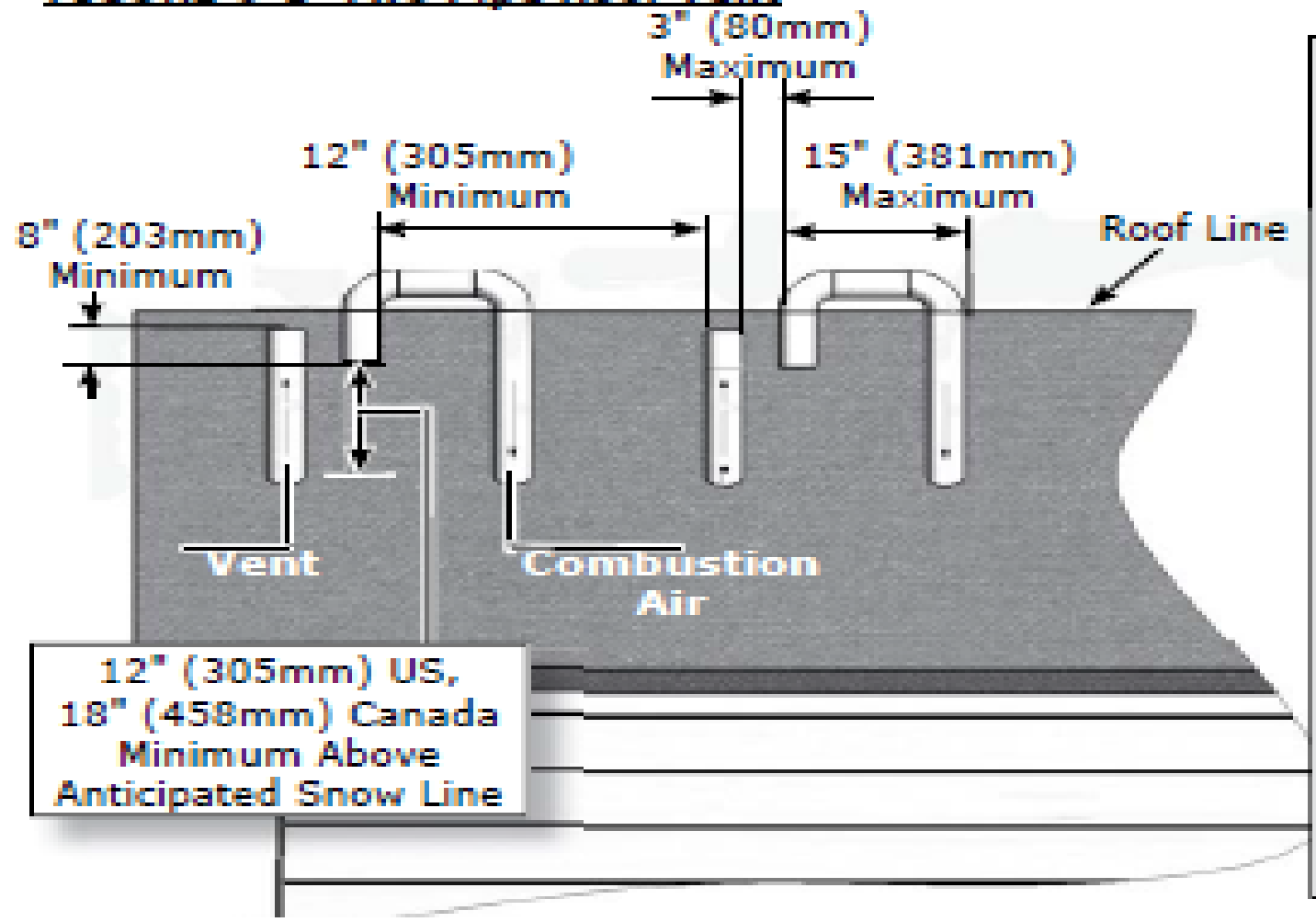

FIGURE 6-2 Two Pipe Side Wall Vent

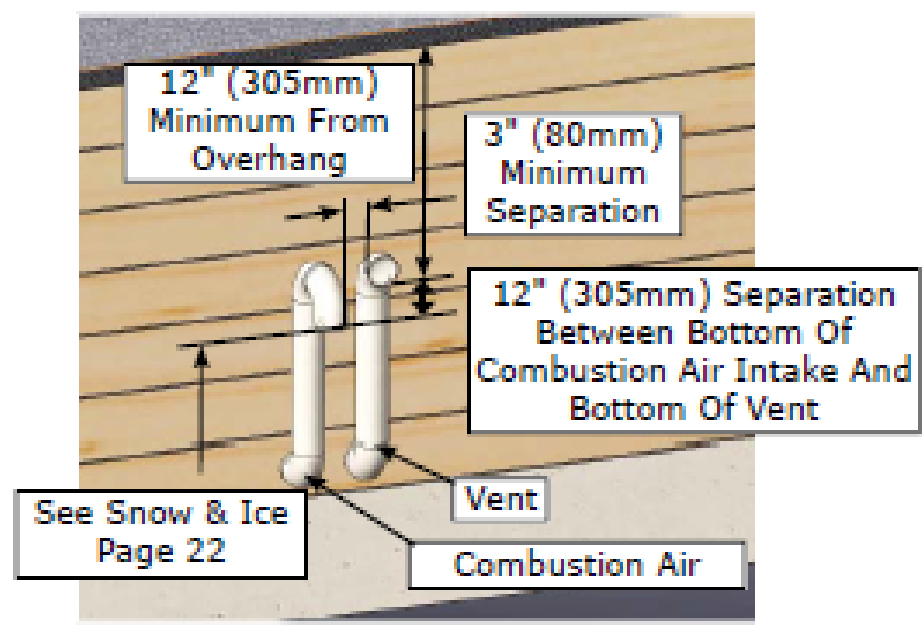
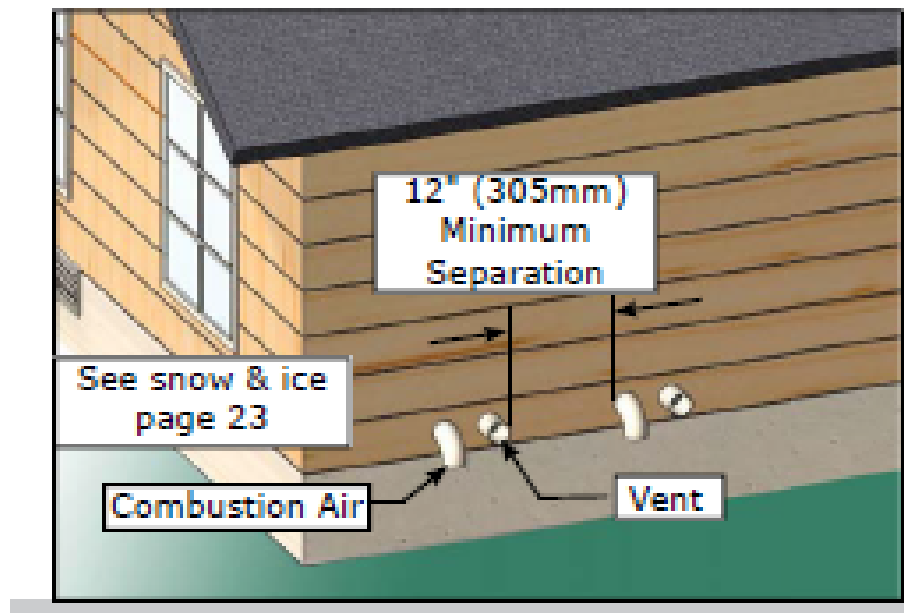

FIGURE 6-3 Two Pipe Side Wall Vent (Multiple Appliances)



- Side wall or roof venting systems allowed
- 1' from or below doors, windows / gravity inlets **except** when using indoor air for combustion. 4' clearance required for single pipe installations.
- 3' above and 10' from any forced air inlet
- Above expected Snow grade (12")
- 3' from a inside "L" corner
- 4' horizontally from, no case above or below electrical, gas meter / regulators or relief equipment
- Cannot be vented under a deck or porch

Piping

This boiler **must** be installed with a Primary/Secondary arrangement or with a low loss accessory.

Use the worksheet in the IOM to calculate your pump size.

Primary Loop Equivalent Length Calculation and Pump Selection, 150/200 MBH (This boiler must be piped Primary/Secondary)				
This chart is valid for piping diagrams on pages XXXXXXXXXXXX				
Instructions:				
Fill in chart using the 1" section first. Then consult chart 4 for pump selection.				
Pump size may be decreased by decreasing equivalent length of pipe.				
Use larger diameter pipe as primary loop to decrease equivalent length. Use chart 2 or 3.				
Note: The figures below are based off of industry average. Consult the valve/fitting manufacturer for exact equivalent length or for fittings not shown below.				
Chart 1				
Pipe diameter	Fitting	Enter Number of fittings	Multiply By	Equivalent Length A x B
1"	90° Elbow		2.5	
	45° Elbow		1.3	
	Tee-branch		5.0	
	Tee-through		1.7	
	Swing check valve		8.3	
	Lift check valve		50.0	
Enter Total 1" straight pipe length in feet Add up numbers in column C				Pump Factor
Chart 2				
Pipe diameter	Fitting	Enter Number of fittings	Multiply By	Equivalent Length A x B
1.25"	90° Elbow		3.1	
	45° Elbow		1.7	
	Tee-branch		6.3	
	Tee-through		2.1	
	Swing check valve		10.4	
	Lift check valve		62.5	
Enter Total 1.25" straight pipe length in feet Add up numbers in column C Total equivalent length of Primary				Pump Factor
Multiply Total of Column C in Chart 2 by 0.35				
Chart 3				
Pipe diameter	Fitting	Enter Number of fittings	Multiply By	Equivalent Length A x B
1.5" (Any pipe/fitting larger than 1.5", count as 1.5")	90° Elbow		3.8	0.00
	45° Elbow		2.0	0.00
	Tee-branch		7.5	0.00
	Tee-through		2.5	0.00
	Swing check valve		12.5	0.00
	Lift check valve		75.0	0.00
Enter Total 1.5" straight pipe length in feet Add up numbers in column C Total equivalent length of Primary				0.00
Multiply Total of Column C in Chart 3 by 0.15				Pump Factor
Chart 4				
Total equivalent length of Primary			Pump options (Minimum)	
From	To	Grundfos	Taco	B&G
0	20	UP 26-99	Taco-0013	NRF-36 speed-3
21	35	UP 26-116	Taco 2400-20	PL-36
36	50	UP 26-150	Taco 2400-50	PL-55
Note: If the heating system uses antifreeze solution 30% or higher, choose the next step larger pump given in the table.				

Calculate your
“Pump Factor”

Note: additional
charts for other
pipe sizes.

Primary Loop Equavelent Length Calculation and Pump Selection, 150/200 MBH (This boiler must be piped Primary/Secondary)

Instructions:

Fill in chart using the 1" section first. Then consult chart 4 for pump selection.

Pump size may be decreased by decreasing equivalent length of pipe.

Use larger diameter pipe as primary loop to decrease equivalent length. Use chart 2 or 3.

Note: The figures below are based off of industry average. Consult the valve/fitting manufacturer for exact equivalent length or for fittings not shown below.

Chart 1		A	B	C
Pipe diameter	Fitting	Enter Number of fittings	Multiply By	Equivalent Length A x B
1"	90° Elbow	8	2.5	20
	45° Elbow		1.3	
	Tee-branch		5.0	
	Tee-through		1.7	
	Swing check valve		8.3	
	Lift check valve		50.0	
Enter Total 1" straight pipe length in feet				20
Add up numbers in column C:				Pump Factor 40

Calculate your
"Pump Factor"

Chart 2		A	B	C
Pipe diameter	Fitting	Enter Number of fittings	Multiply By	Equivalent Length A x B
1.25"	90° Elbow	8	3.1	24.8
	45° Elbow		1.7	
	Tee-branch		6.3	
	Tee-through		2.1	
	Swing check valve		10.4	
	Lift check valve		62.5	
Enter Total 1.25" straight pipe length in feet				20
Add up numbers in column C Total equivalent length of Primary				44.8
Note: Sizes larger than boiler connection require correction factor. → Multiply Total of Column C in Chart 2 by 0.35				Pump Factor 15.68

Using Pump Factor select the correct pump below.

Chart 4				
Total equivalent length of Primary		Pump options (Minimum)		
From	To	Grundfos	Taco	B&G
0	20	UP 26-99	Taco-0013	NRF-36 speed-3
21	35	UP 26-116	Taco 2400-20	PL-36
36	50	UP 26-150	Taco 2400-50	PL-55
Note: If the heating system uses antifreeze solution 30% or higher, choose the next step larger pump given in the table.				

Single Boiler Primary / Secondary Two-Pipe Zoned System With Zone Pumps

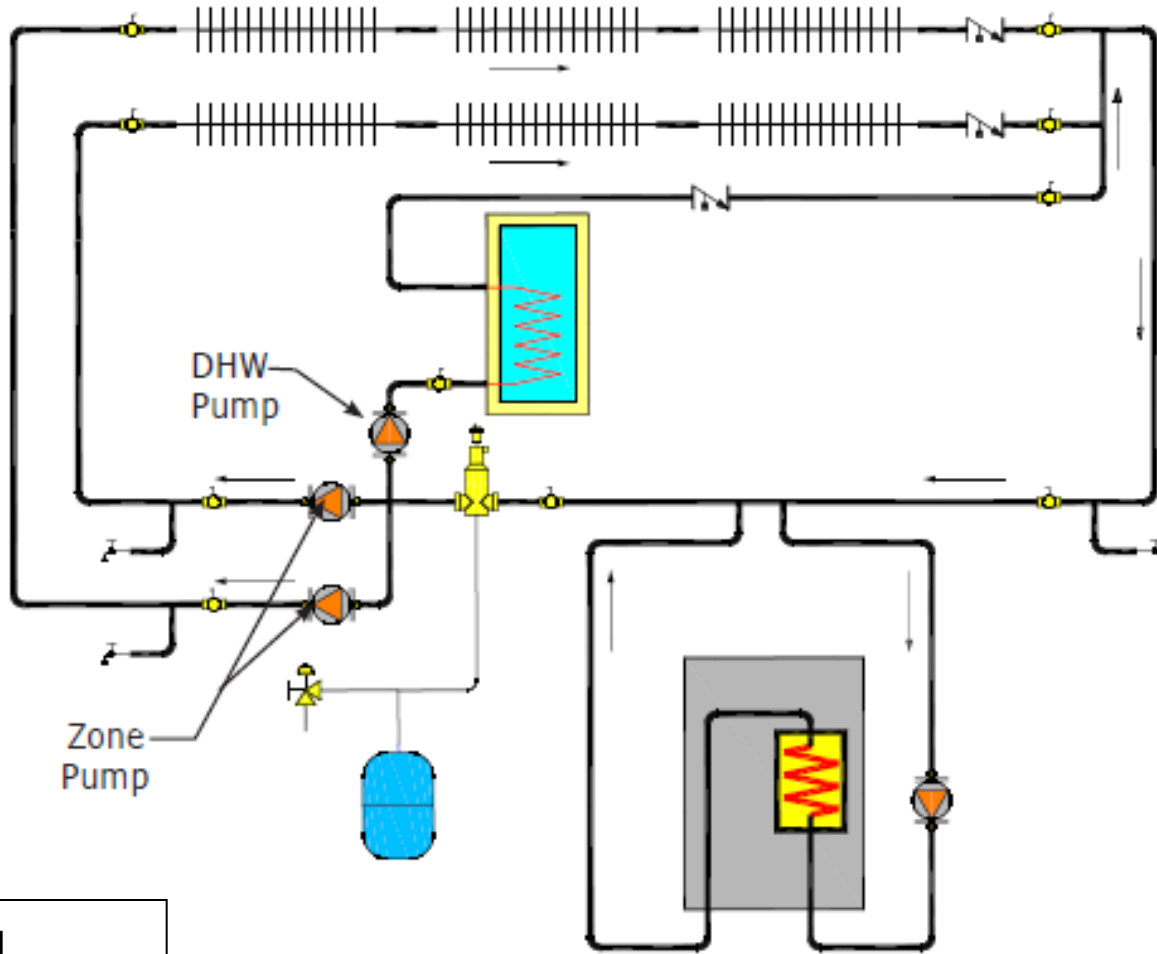

Additional Piping
Diagrams in I.O.M.

Single Boiler Primary / Secondary Two-Pipe Zoned System With Zone Pumps

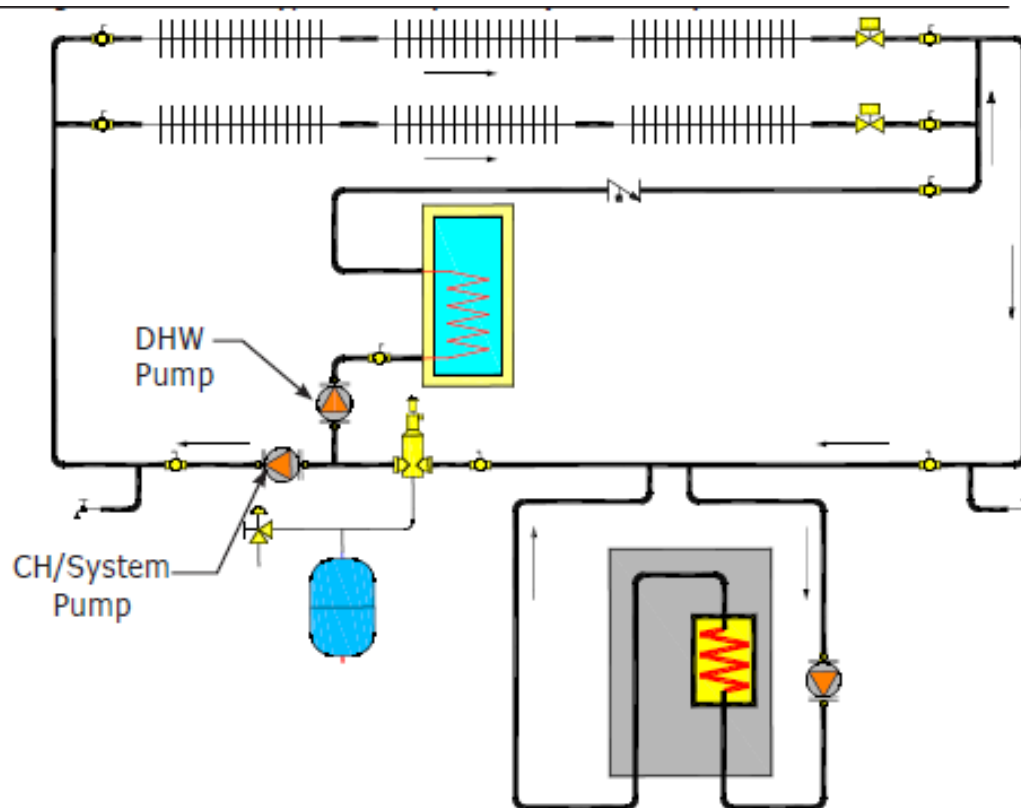

Additional Piping
Diagrams in I.O.M.

Multiple Boiler Primary / Secondary Two-Pipe Zoned System With Zone Pumps

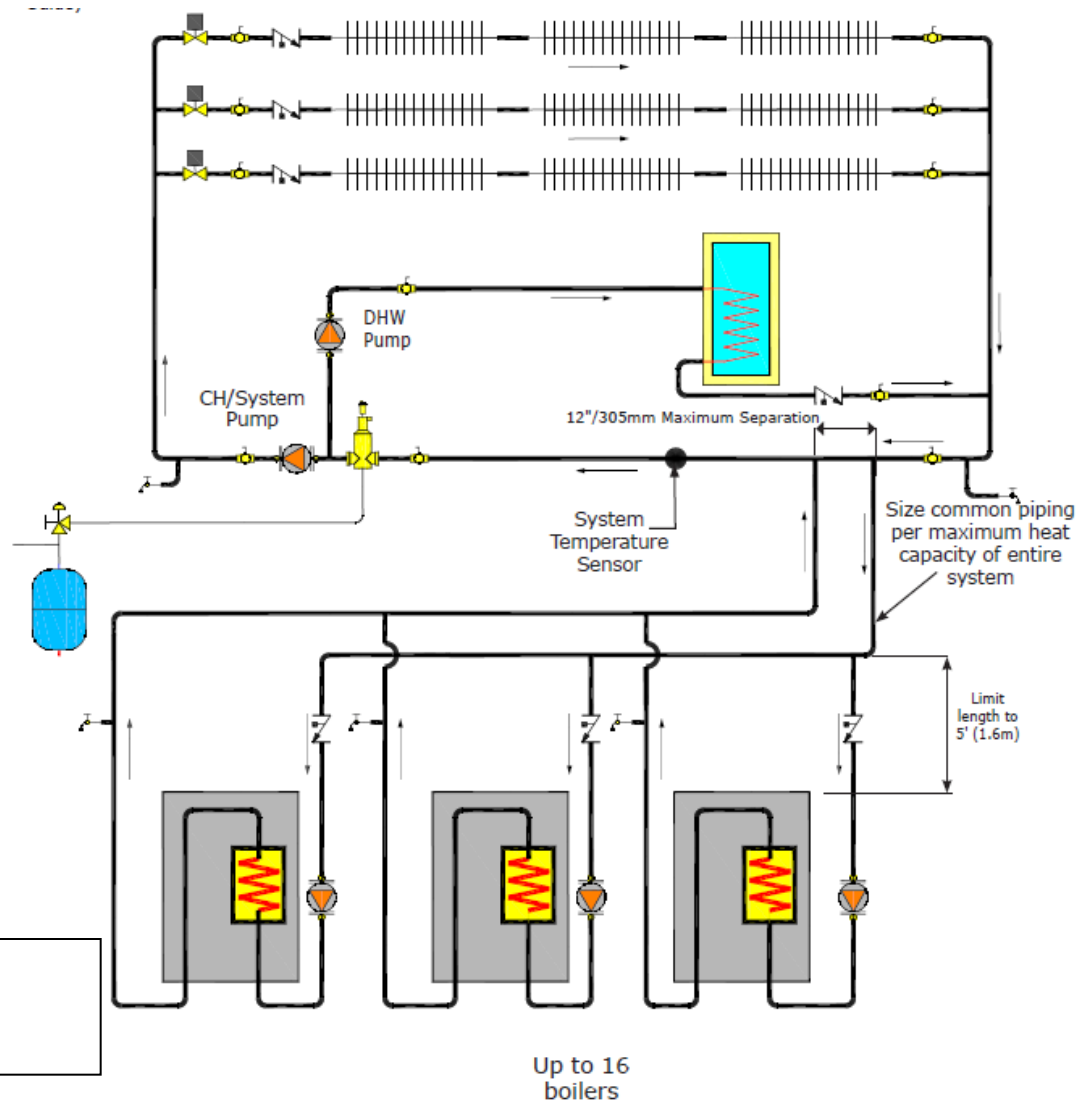

Installing contractor must furnish and install a Low Water Cutoff device.

The Low Voltage Terminal Strip has 2 landing points for the LWCO safety switch. Separate power source must be field provided (24 vac or 120 vac).

Failure to install a LWCO will produce a lockout error E36 on the boiler display on startup.

- Wiring connections located inside, bottom left
- Incoming 120 volt
- Primary Loop circulator pump
- Domestic hot water circulator pump
- Central heating circulator pump

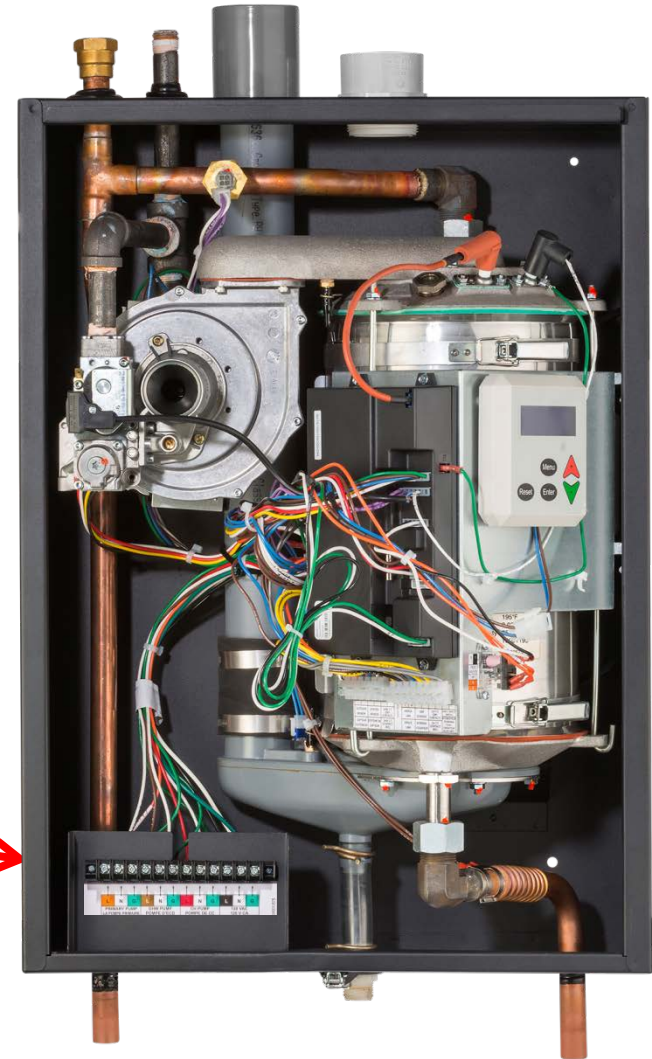
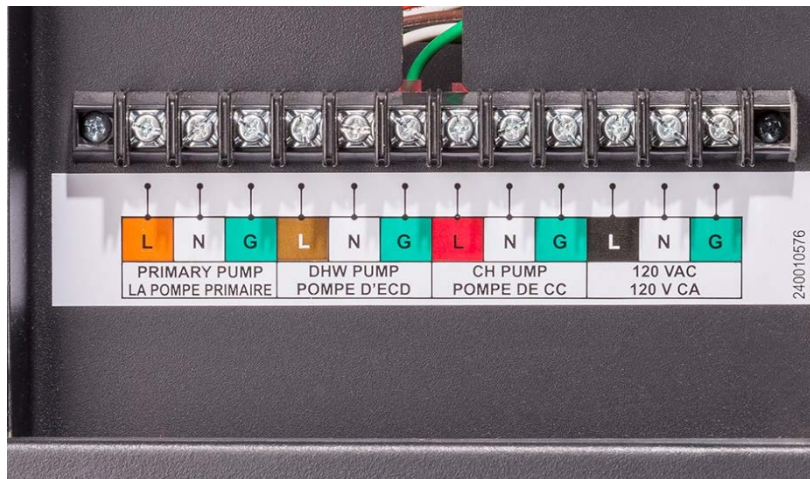
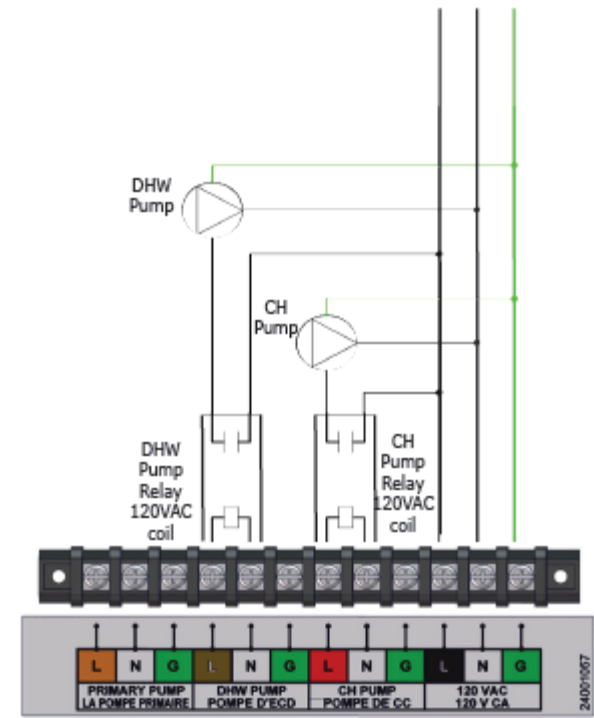

Table 9 - Maximum Allowable Current Draw

MBH	CH PUMP	DHW PUMP	PRIMARY PUMP	NOTE
50 75 100	1 A*	1 A*	10 A**	*Powered by Control Board
150 200	10 A**	10 A**	10 A**	**Powered by installed 10 Amp relay

If CH or DHW pump current is more than the maximum allowable current draw install proper field sourced relays as shown in figure 8-3.
Maximum allowable total amperage of all 3 pumps must not exceed 20 amps.

FIGURE 8-3 Isolation Relays for CH System Pump and DHW Pump



Built-in 10 amp relay for Primary Pump all models & CH/DHW pumps on 150-200 models.

Low voltage terminal strip located inside boiler

Connections

- Outdoor Sensor
- System Sensor
- DHW T-T
- Argus Link
- User Interface
- CH T-T
- LWCO end switch

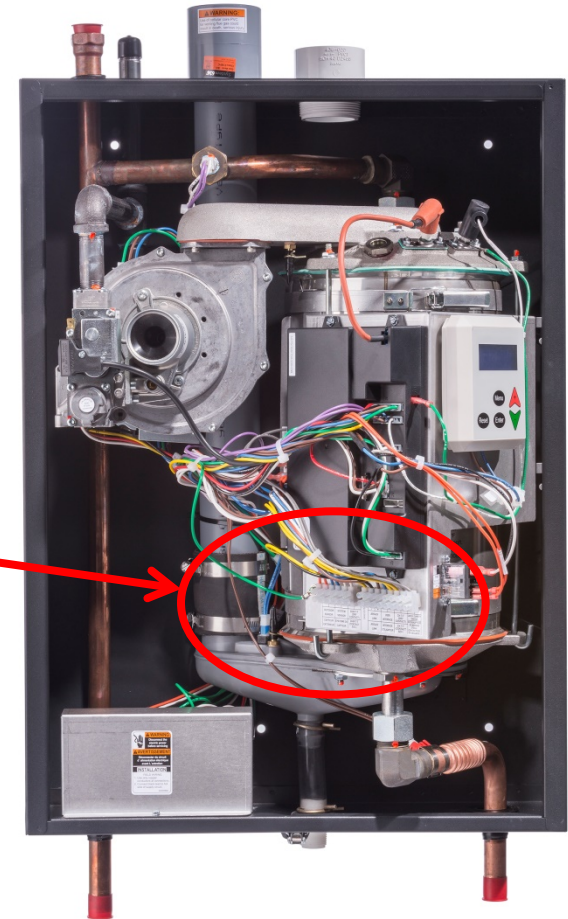
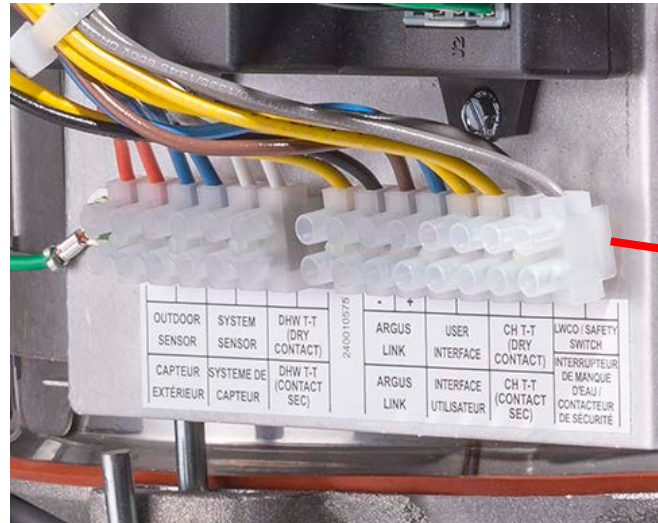

One Zone Heat or One Zone Heat & Indirect

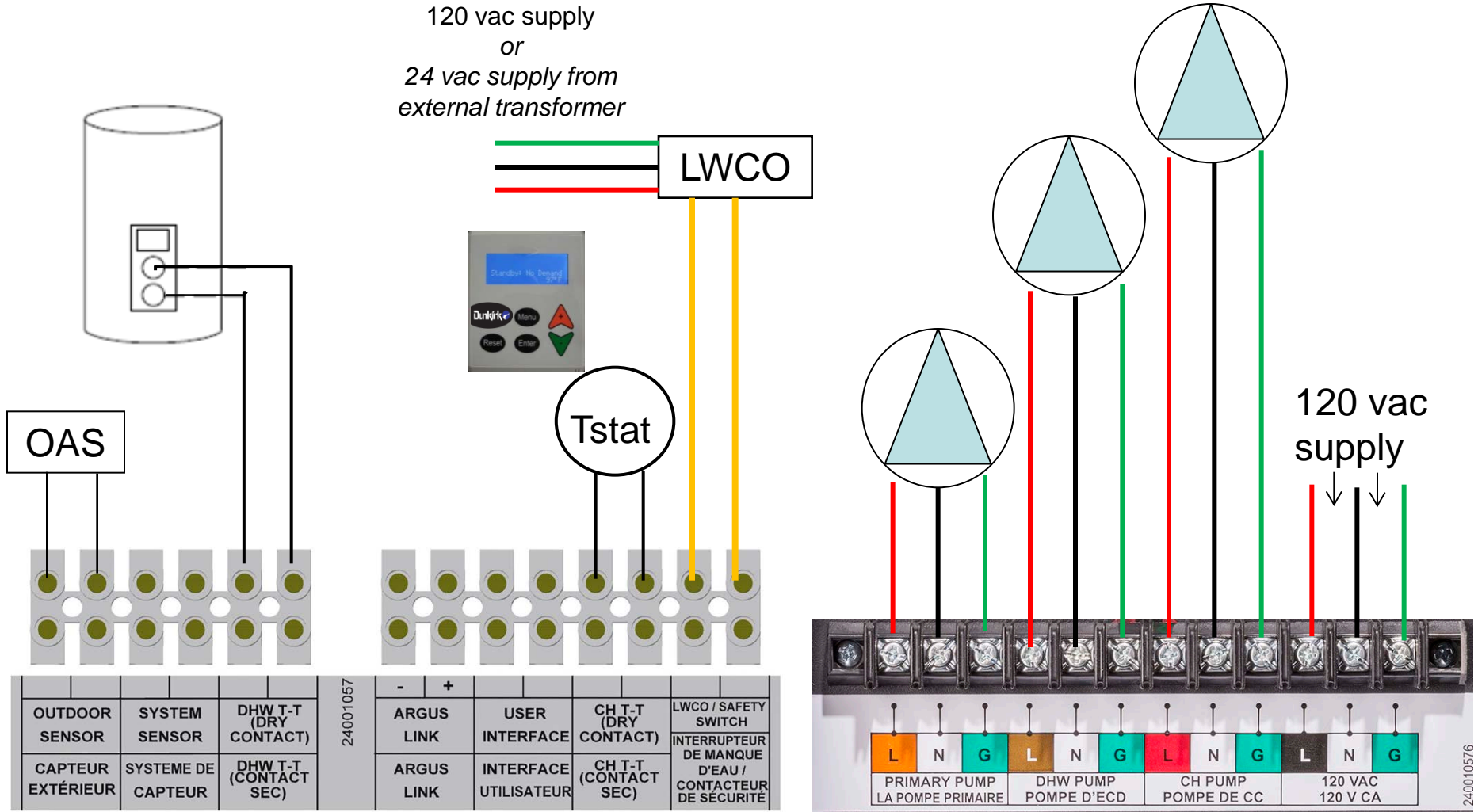

Typical Cast Iron Wiring

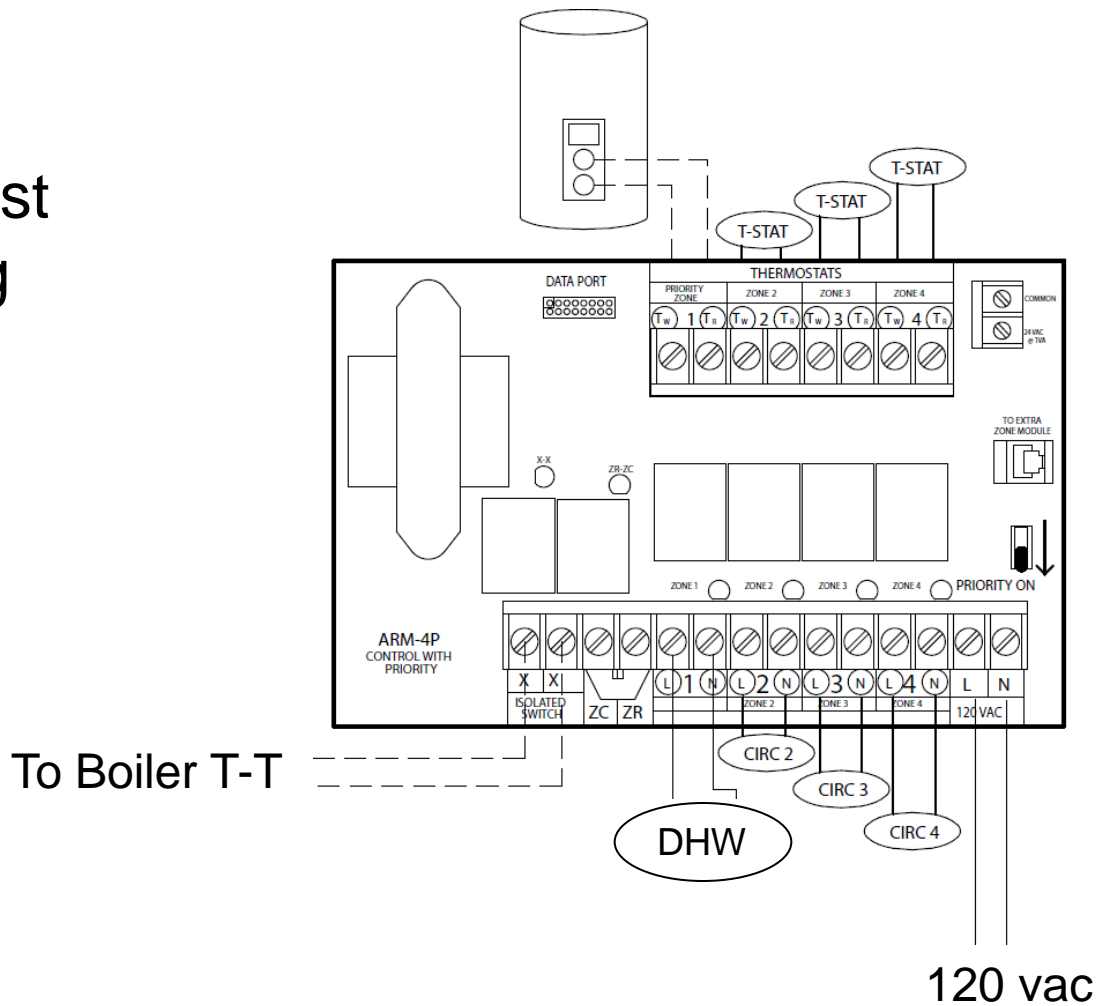

If Done this way on the SSV it will be

Incorrect---

WHY?

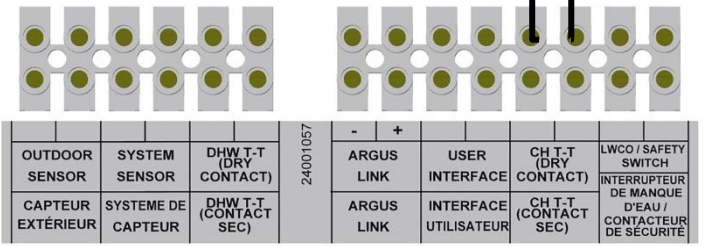
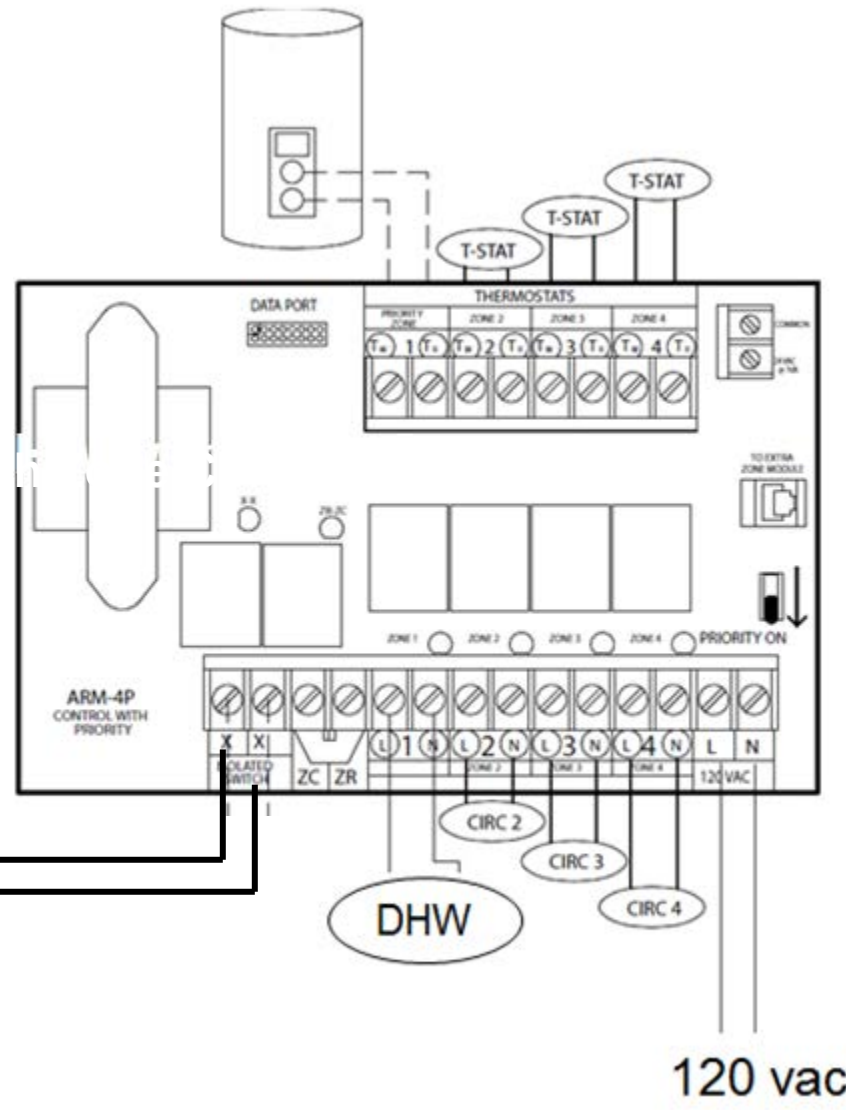

120 vac

If Done this way on the SSV it will be

Incorrect---

WHY?

Hint: Installed in December and it worked fine until spring.

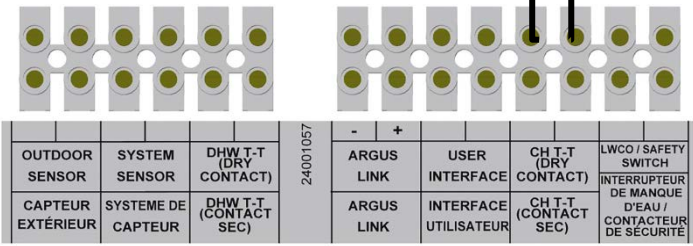
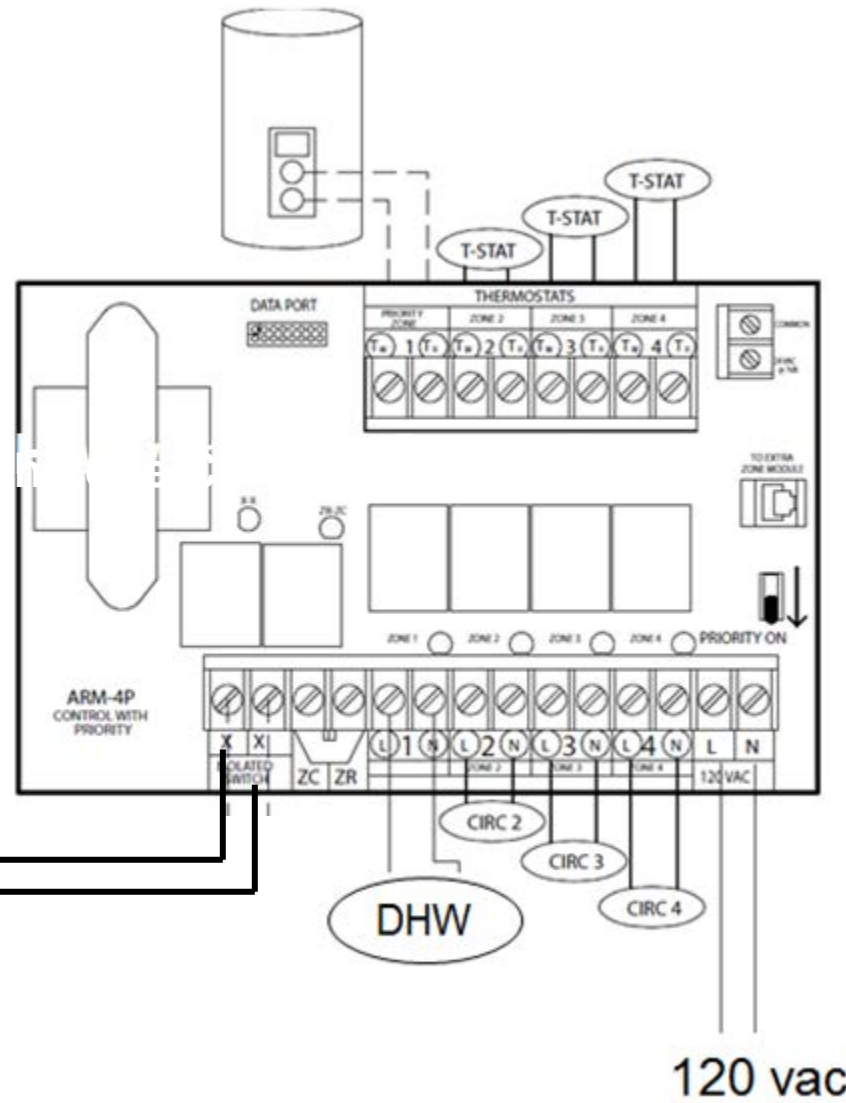

120 vac

If Done this way on the SSV it will be

Incorrect---

WHY?

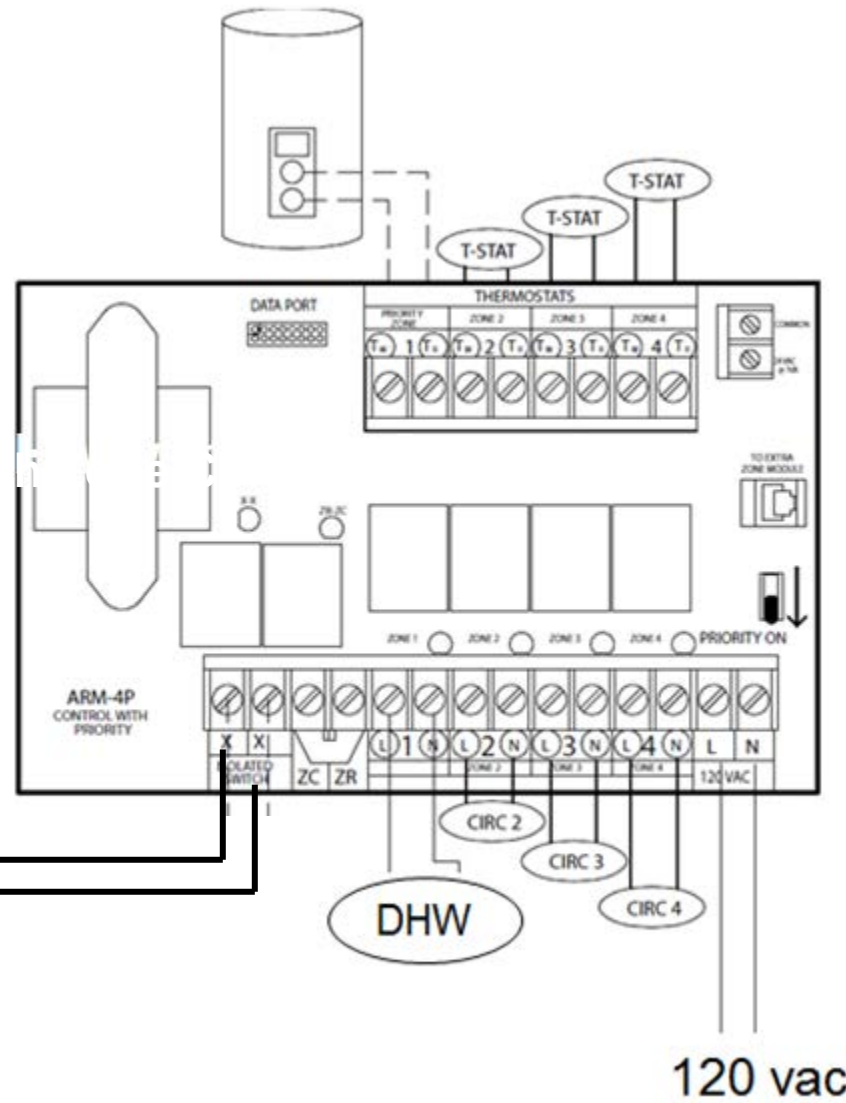
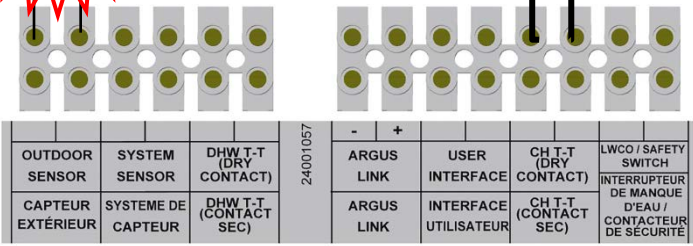
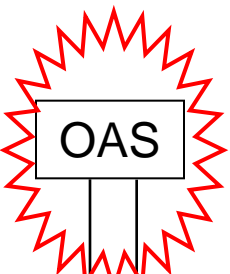

120 vac

CORRECT

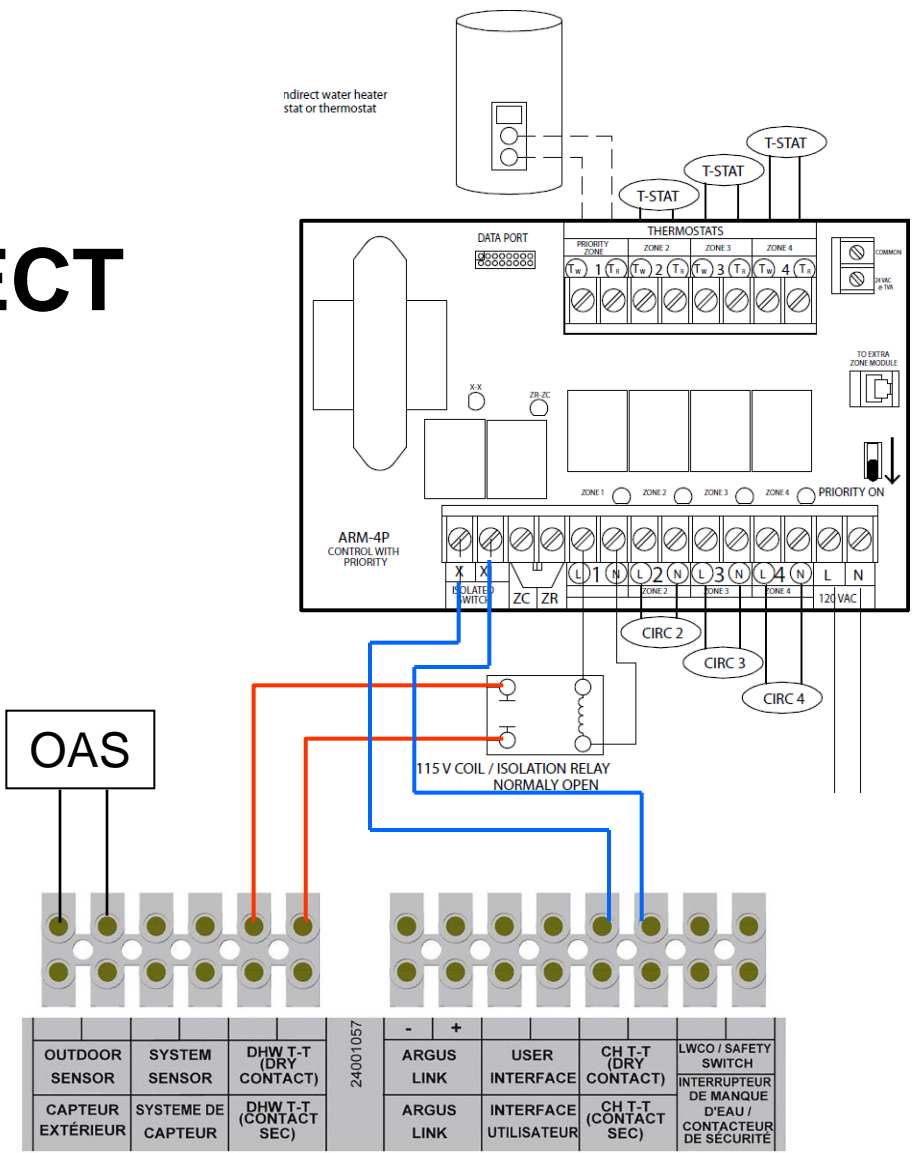

Argo AZ-4CP Zone Valve Control

Note: End switch of DHW zone valve to boiler DHW T-T

(No need for additional relay.)

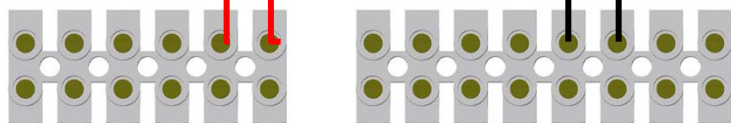
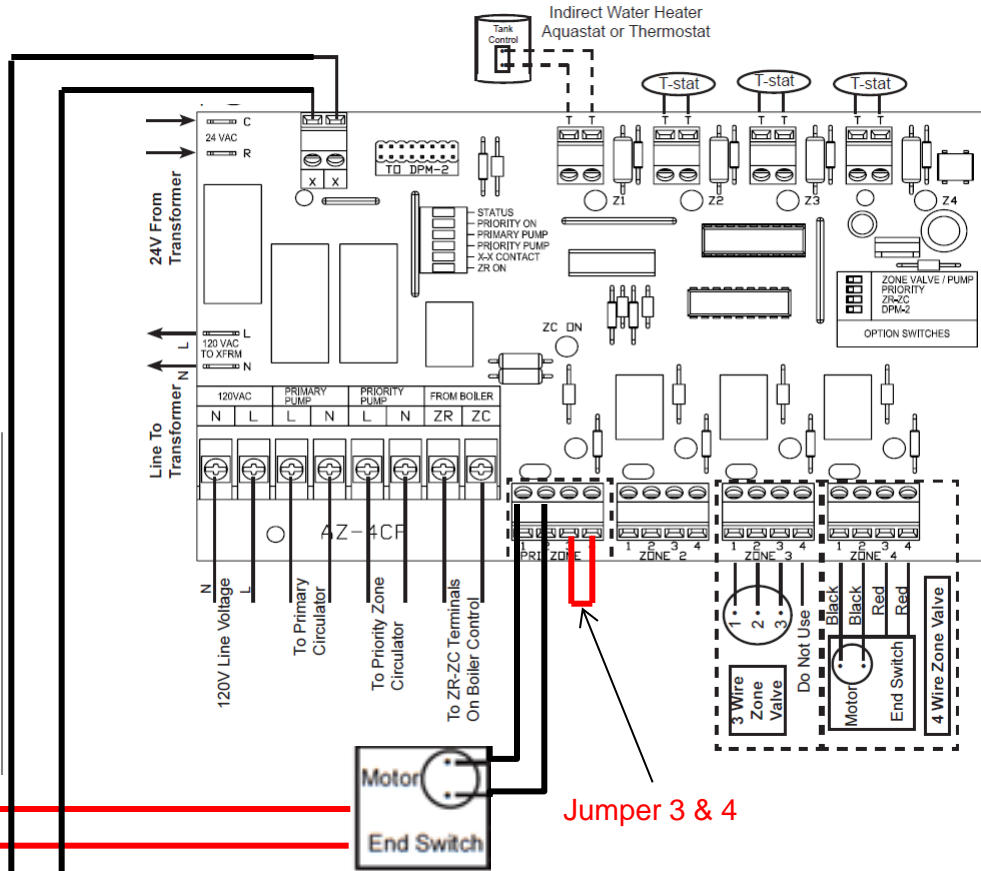

			24-001057	-	+				
OUTDOOR SENSOR	SYSTEM SENSOR	DHW T-T (DRY CONTACT)		ARGUS LINK	USER INTERFACE	CH T-T (DRY CONTACT)	LWCO / SAFETY SWITCH		
CAPTEUR EXTÉRIEUR	SYSTEME DE CAPTEUR	DHW T-T (CONTACT SEC)	ARGUS LINK	INTERFACE UTILISATEUR	CH T-T (CONTACT SEC)	INTERRUPTEUR DE MANQUE D'EAU / CONTACTEUR DE SECURITE			

Multiple Boiler System

- ARGUS™ control on first boiler will act as the master control. Requires a Multiple Boiler Install Kit p/n 550002186
- No need for expensive MBS control

Wiring

- Daisy chain wiring from the master to additional boilers with low voltage wiring from the ARGUS link terminals (2-conductor low voltage wire, maintain polarity)

- **ARGUS™**
- **Display / mother board**
- **Fuse protected**

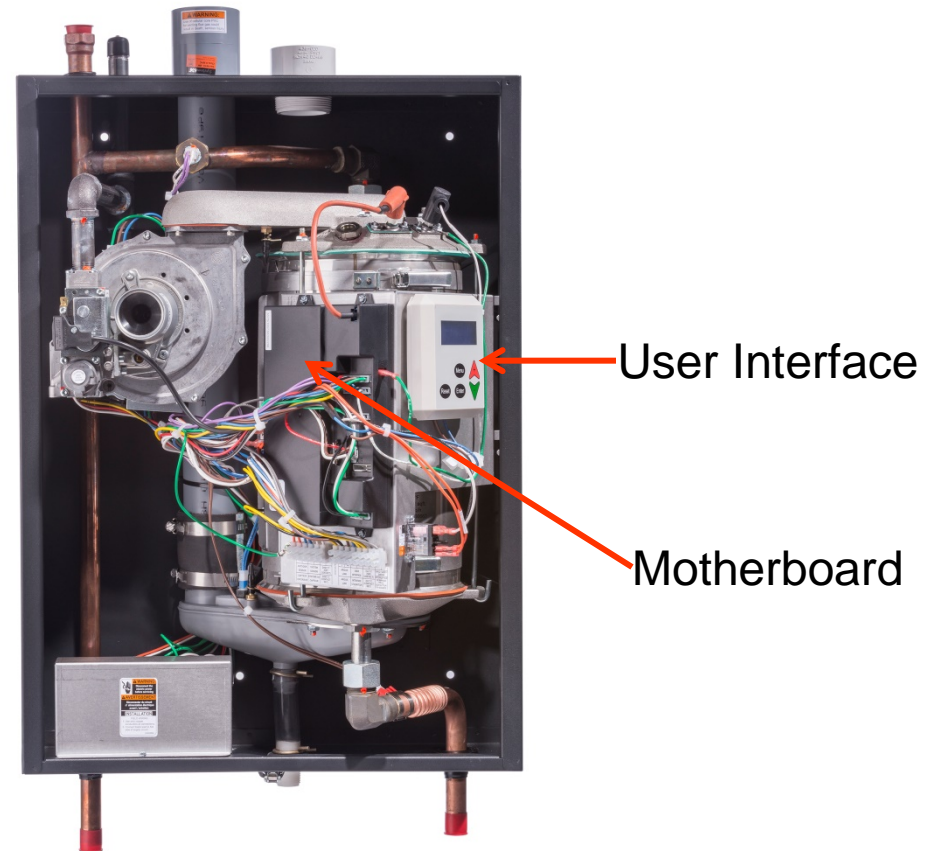

Key Features:

- User Interface with full text readout of error codes + diagnostics.
- Integrated Multiple boiler control w/ simplified physical connection.



S t a n d b y : N o D e m a n d
7 5 ° F

F P B G

C e n t r a l H e a t i n g
6 5 % 9 5 ° F

F P B G D

D o m e s t i c H o t W a t e r
9 5 % 1 6 5 ° F

Boiler operates in standby mode until demand for Central Heat (CH) or Domestic Hot Water (DHW) is detected.

Boiler Status Indicator

F = Flame Detected

P = Boiler Pump On

B = Combustion Air Blower

S = Spark Ignition On

G = Gas Valve Open

D = DHW Pump On



```
F P B S G D
S e r v i c e   R e m i n d e r
S t a n d b y :   N o   D e m a n d
                                     7 5 ° F
```

Service Reminder Indicator

Boiler in Standby Mode

Boiler Supply Water

Temperature Indicator



ARGUS™ Control

Key	Description
RESET	Reset Control / System
MENU	Enter / Exit user menu
ENTER	Select Menu item Confirm new parameter value
▲ PLUS	Scroll up to next menu item Go to next screen Increase value
▼ MINUS	Scroll down to next menu item Go to previous screen Decrease value

**EASY TO PROGRAM
EASY TO UNDERSTAND**

TWO MENU'S: MAIN MENU & INSTALLERS MENU

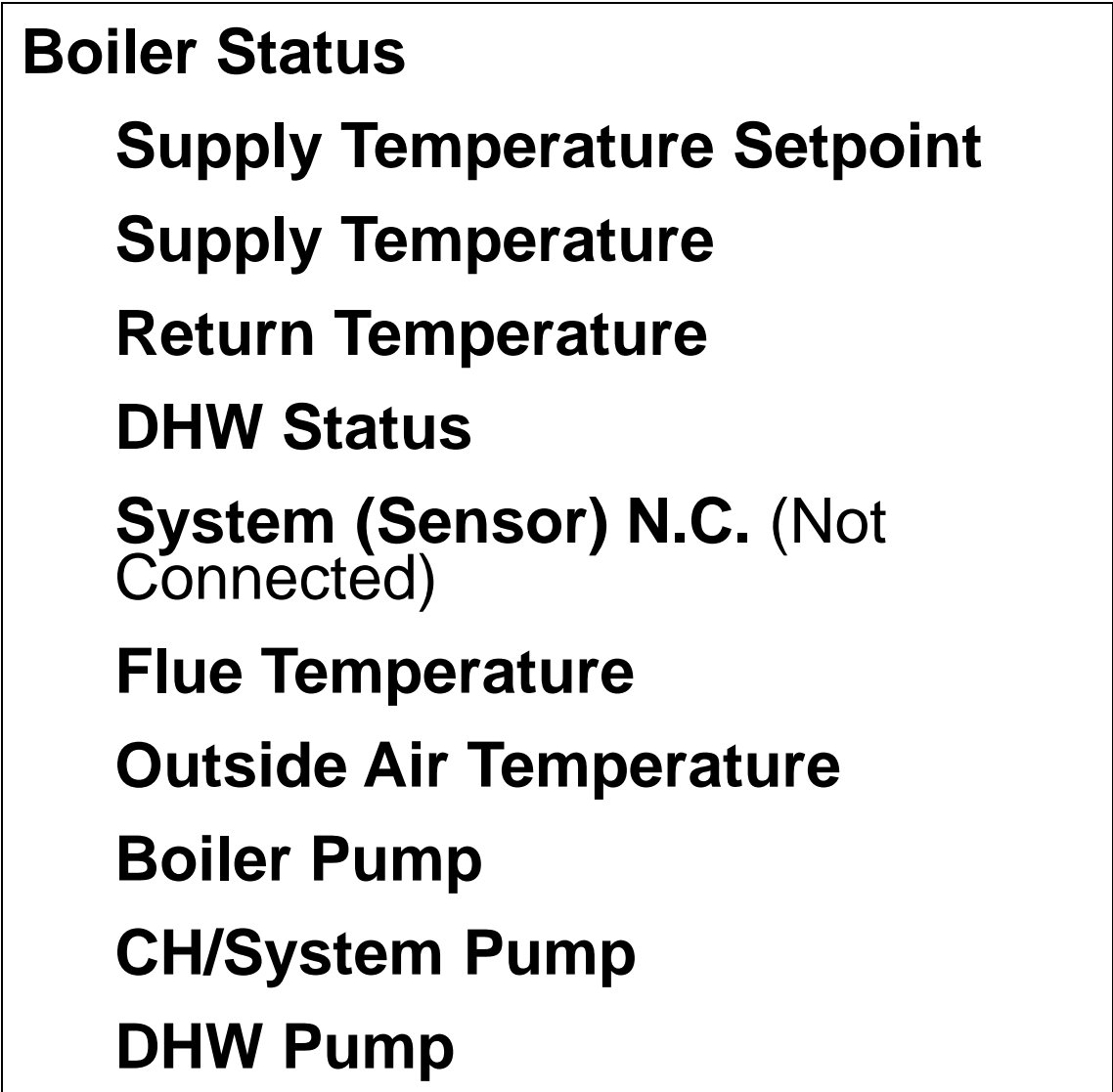
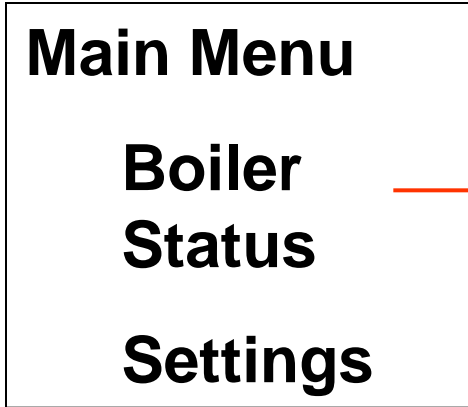

Key	Description
RESET	Reset Control / System
MENU	Enter / Exit user menu
ENTER	Select Menu item Confirm new parameter value
▲ PLUS	Scroll up to next menu item Go to next screen Increase value
▼ MINUS	Scroll down to next menu item Go to previous screen Decrease value

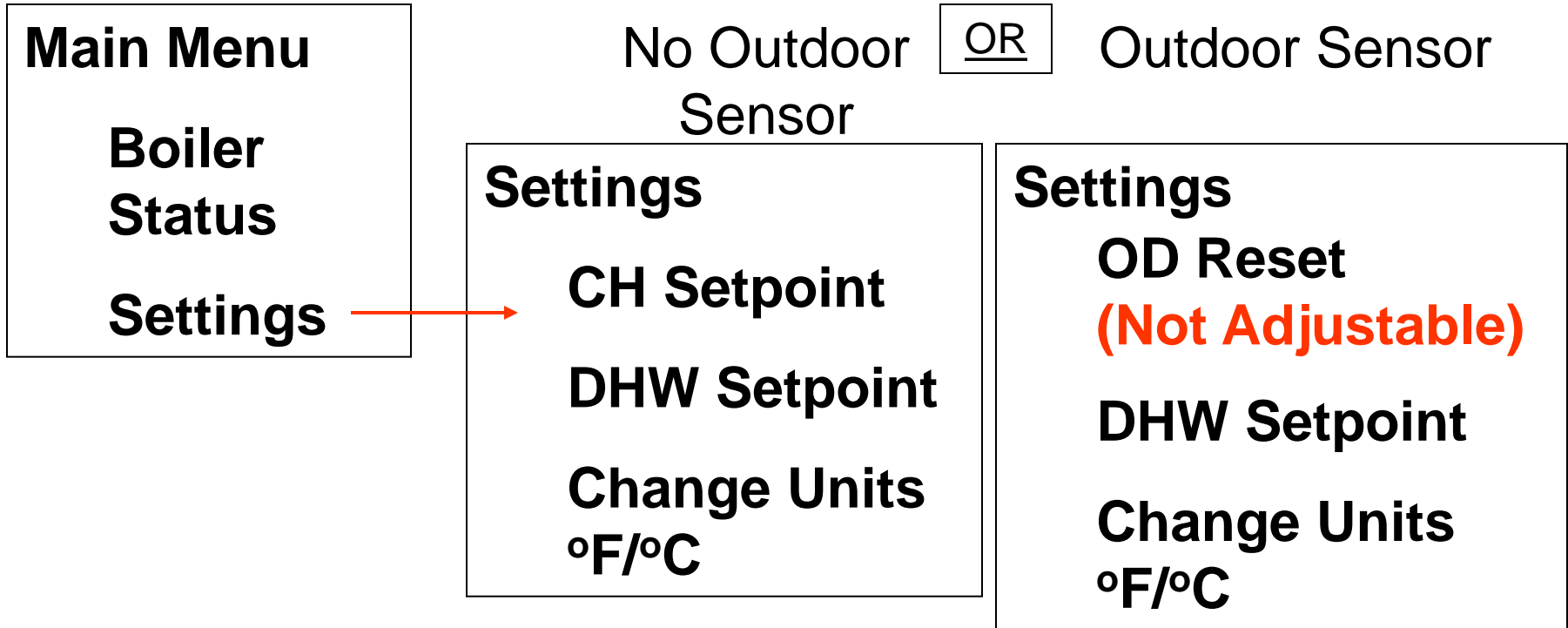

Key	Description
RESET	Reset Control / System
MENU	Enter / Exit user menu
ENTER	Select Menu item Confirm new parameter value
▲ PLUS	Scroll up to next menu item Go to next screen Increase value
▼ MINUS	Scroll down to next menu item Go to previous screen Decrease value

Sample Screen Display

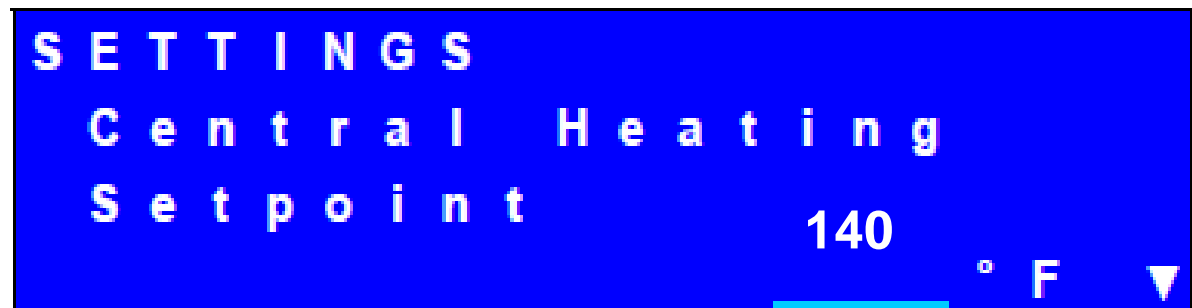

(Menu & Enter Buttons – 4 seconds)

Installer Menu

Boiler Status

Boiler Config

CH Settings

DHW Settings

**Cascade
Settings**

System Test

Boiler Status

**Fan Speed – Actual, Low, IGN,
High**

Flame

Signal

Failures

Ignition Attempts

Successful

Failed

Boiler Run Time

CH – hours

DHW – hours

**Blocking Errors (non-volatile
memory for 16)**

**Locking Errors (non-volatile
memory for 16)**

Key	Description
RESET	Reset Control / System
MENU	Enter / Exit user menu
ENTER	Select Menu item Confirm new parameter value
▲ PLUS	Scroll up to next menu item Go to next screen Increase value
▼ MINUS	Scroll down to next menu item Go to previous screen Decrease value

(Menu & Enter Buttons – 4 seconds)

Installer Menu

Boiler Status

Boiler Config

CH Settings

DHW Settings

**Cascade
Settings**

System Test

Boiler Config

Address Selection

LWCO – enable/disable

Pump Mode

CH or Ch & DHW - 0

System Pump - 4

Service Reminder

On/Off

Duration

Key	Description
RESET	Reset Control / System
MENU	Enter / Exit user menu
ENTER	Select Menu item Confirm new parameter value
▲ PLUS	Scroll up to next menu item Go to next screen Increase value
▼ MINUS	Scroll down to next menu item Go to previous screen Decrease value

(Menu & Enter Buttons – 4 seconds)

Installer Menu

Boiler Status

Boiler Config

CH Settings

DHW Settings

Cascade Settings

System Test

CH Settings

CH Mode

- 0- CH with Tstat
- 1- CH: Tstat & Outdoor Sensor
- 2- CH: No Tstat, Full setback by OAS
- 3- CH: Permanent Demand

Warm Weather Shutdown (70) *

Reset Curve Design – High end (180 @ 25)* (A)

Reset Curve Design – Low end (100 @ 70)* (B)

Reset Curve Min/Max Temperatures (180/70)* (C-D)

Boost Function

Max Power

*Defaults

Figure A-2 Outdoor Reset Curve
Calculated supply temperature follows thick black line in graph below based on outdoor temperature.

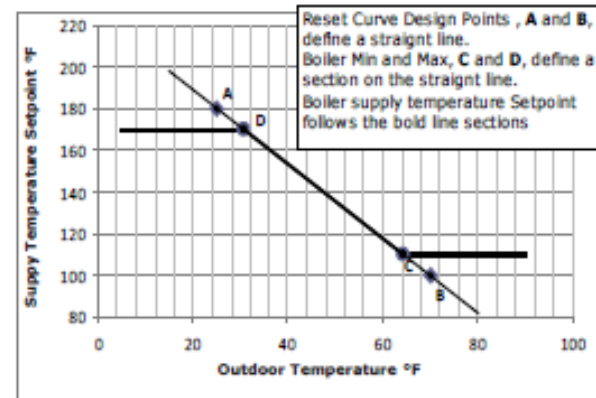

Key	Description
RESET	Reset Control / System
MENU	Enter / Exit user menu
ENTER	Select Menu item Confirm new parameter value
▲ PLUS	Scroll up to next menu item Go to next screen Increase value
▼ MINUS	Scroll down to next menu item Go to previous screen Decrease value

(Menu & Enter Buttons – 4 seconds)

Installer Menu

Boiler Status

Boiler Config

CH Settings

DHW Settings

**Cascade
Settings**

System Test

DHW Settings

DHW Mode

DHW Priority (Default – 30 min)

Key	Description
RESET	Reset Control / System
MENU	Enter / Exit user menu
ENTER	Select Menu item Confirm new parameter value
▲ PLUS	Scroll up to next menu item Go to next screen Increase value
▼ MINUS	Scroll down to next menu item Go to previous screen Decrease value

(Menu & Enter Buttons – 4 seconds)

Installer Menu

Boiler Status

Boiler Config

CH Settings

DHW Settings

**Cascade
Settings**

System Test

Cascade Settings

Emergency Setpoint

Start Delay Time

Stop Delay Time

Start Boiler Differential

Stop Boiler Differential

Calculated Setpoint: Max Offset Up

**Calculated Setpoint: Max Offset
Down**

Next Boiler Start Rate

Next Boiler Stop Rate

Rotation Interval

Boilers for DHW

Start Modulation Delay Factor

System Test – Post Pump Time

Key	Description
RESET	Reset Control / System
MENU	Enter / Exit user menu
ENTER	Select Menu item Confirm new parameter value
▲ PLUS	Scroll up to next menu item Go to next screen Increase value
▼ MINUS	Scroll down to next menu item Go to previous screen Decrease value

(Menu & Enter Buttons – 4 seconds)

Installer Menu

Boiler Status

Boiler Config

CH Settings

DHW Settings

**Cascade
Settings**

System Test

System Test Settings

System test power: (Low, IGN, High)

Boiler Pump (On / Off)

CH Pump (On / Off)

DHW Pump (On / Off)

Key	Description
RESET	Reset Control / System
MENU	Enter / Exit user menu
ENTER	Select Menu item Confirm new parameter value
▲ PLUS	Scroll up to next menu item Go to next screen Increase value
▼ MINUS	Scroll down to next menu item Go to previous screen Decrease value



Current System Status

----- Lockout Alarm Blocking Too Long Error	A 0 0	Go to Page 40	F P ----- Blocking Error False Flame Detect	E 3 5	Go to Page 44
----- Lockout Alarm Ignit Error	A 0 1	Go to Page 41	----- Blocking Error Low Water Cutoff	E 3 6	Go to Page 45
----- Lockout Alarm GV Relay Error	A 0 5	Go to Page 40	----- Blocking Error Return Temp	E 4 0	Go to Page 46

Error Description

Error Code #

Page # in IOM

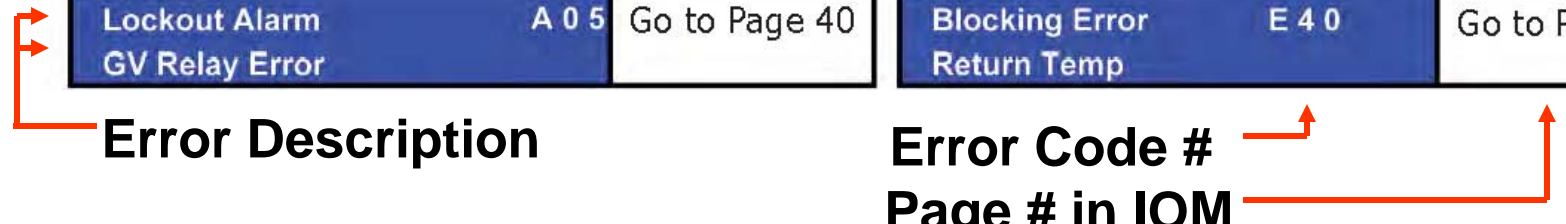

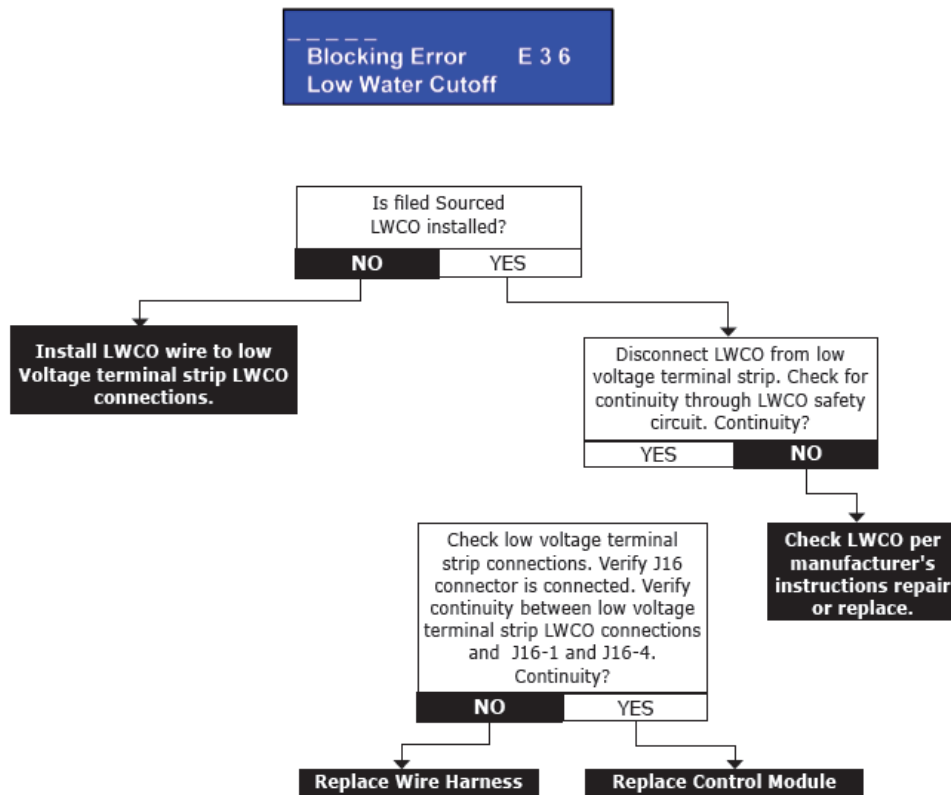

- Flow chart design
- Error code listed in **blue box**
- Easy to follow and understand
- Step by step procedure



- Combustion and proper installation set up required for all high efficiency models
 - **Combustion Analyzer** - Properly check CO² level of exhaust
 - **Gas Meter** – U-tube manometer or gauge set to check inlet gas pressure
 - To change gas inlet pressure adjust at system regulator **NOT** THE GAS VALVE REGULATOR
 - **Sampling port located on Flue Collector**
- No need to drill sample port in flue pipe!!*

Gas	CO2		CO
	Min	Max	
Natural Gas	9.0	9.5	<200ppm
Propane	10.0	11.0	<200ppm



- Do not adjust the gas regulator on the gas valve

- Gas inlet pressure tap
Natural: 3" – 13.5" w.c.
LP: 5" – 13.5" w.c.

- Throttle screw – to adjust the air / gas mixture on the venturi assembly

- All gas pressure changes are done at the utility regulator external of the equipment

Combustion: Built-in Sample Port

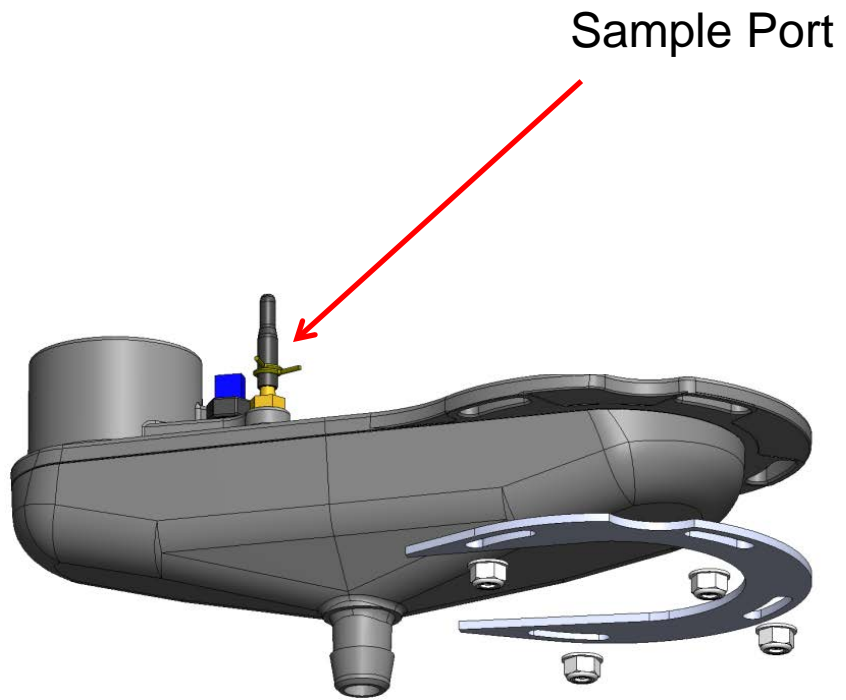



- Turn off gas and electrical
- Remove blower / burner assembly and examine flue passageways
- Remove igniter and sensor off top of heat exchanger
- Burner may be cleaned by inserting an air hose into blower opening of casting and blowing air thru heat exchanger side

- Clean heat exchanger with nylon brush if required
- Any remaining sediment can be removed with a shop vacuum snorkel
- Re-install refractory and burner / gas valve
- Visually inspect condensate trap – re-fill trap (If required)

Critical Installation Points



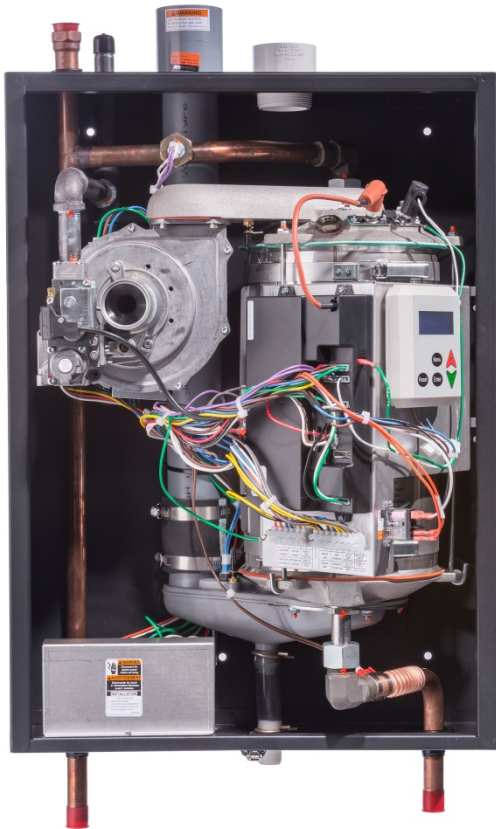

- Air in the system affects Low Mass Boilers differently than cast iron boilers
- Heat Exchanger Water Volume is much lower
- Air removal methods different
- Water Flow rates are important
- How does Antifreeze affect the System?
- Clean Water



- Cast Iron Boilers are more tolerant of system air issues.
- Gravity works with us



Cast Iron Air Scoop

- Based on venturi principal; accelerated flow yields reduced pressure, causing dissolved gases to separate
- Slow Process – Less Effective
- Proper location Critical for air scoop to remove air



Micro-Bubble Separator

- Based on the principal that reduced velocity plus multiple impact sites allow air bubbles to separate easily
- Faster process, much more effective
- Location Not Critical for Separator to function

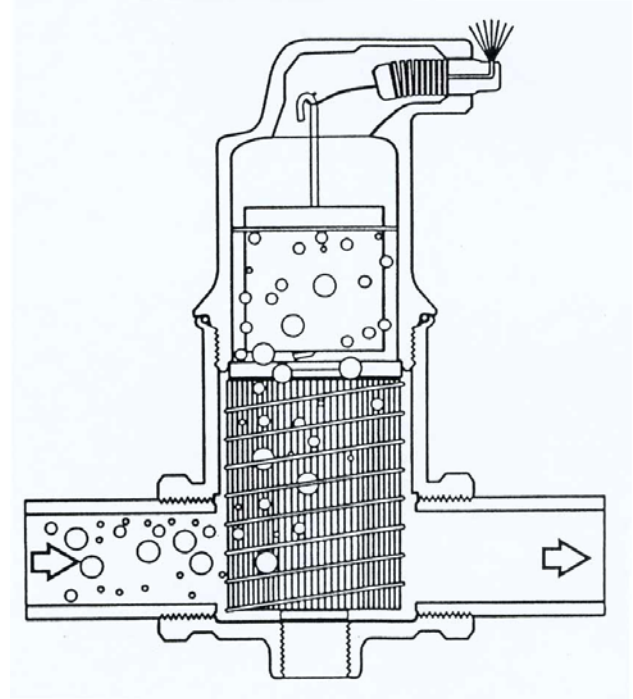

How to properly purge a system

- When filling the boiler you must relieve the air in the boiler by opening the pressure relief valve
- Before firing the boiler you should turn on the Boiler Pump and the CH pump by the System Test Menu and let the water circulate while listening for air.
- If air is present repeat system and boiler purging.

- Low System Flow Rates will cause Boiler to heat quickly
- Cycles frequently on High Limit-Less Efficient
- Harder to get air out of boiler

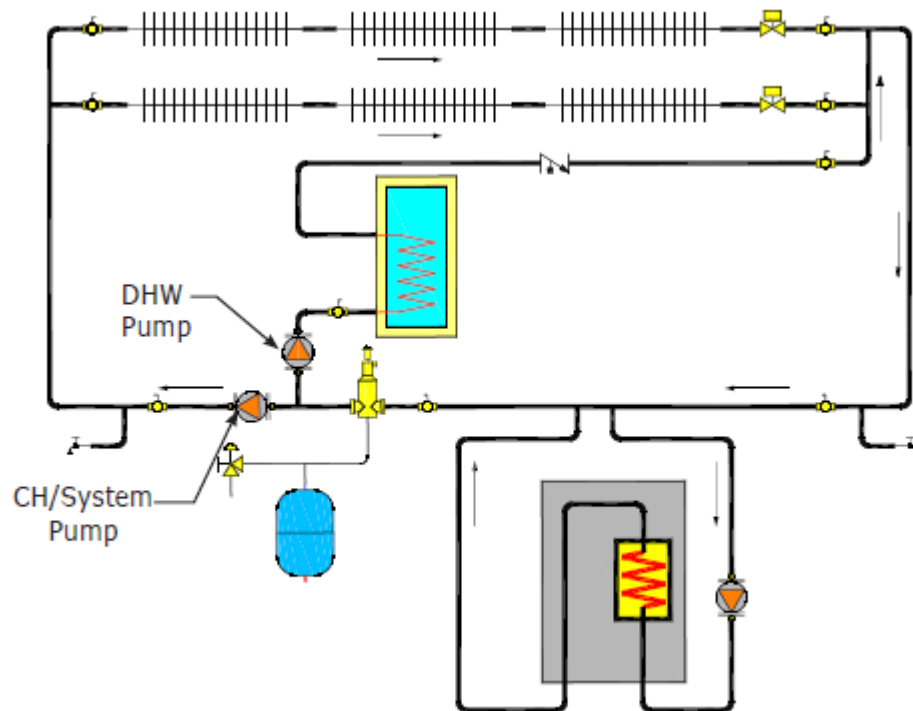

- Treated (Softened) water can reduce circulator capacity by 10-15% !!
- If reduced flow rate is causing noise issues a higher head pump may resolve the problem.

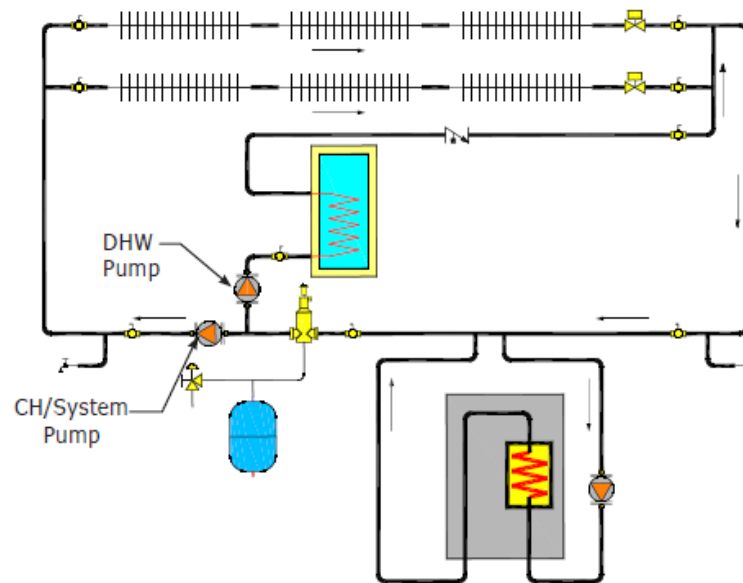

- Water quality can affect system performance
- Dirty brackish water can lower boiling point
- Also makes air removal more difficult
- Using a strainer in the return line helps greatly



- If existing system is contributing to air removal difficulties raise the boiling point.
- Increase system pressure to 20 psi.
- Remember to pump Expansion tank!
- If higher pressure needed change Boiler relief to 50 psi and increase system pressure further.
- Remember to pump Expansion tank!

Normal Tank Operation

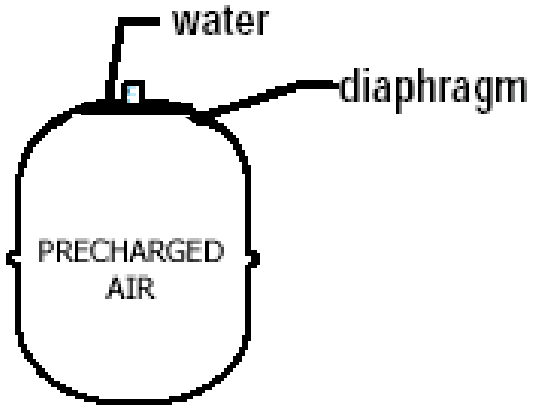

System Off

System Pressure=12

Tank Pressure=12

Normal Tank Operation

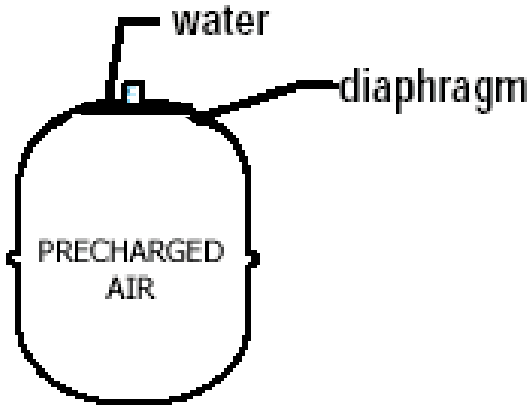

System Off

System Pressure=12

Tank Pressure=12

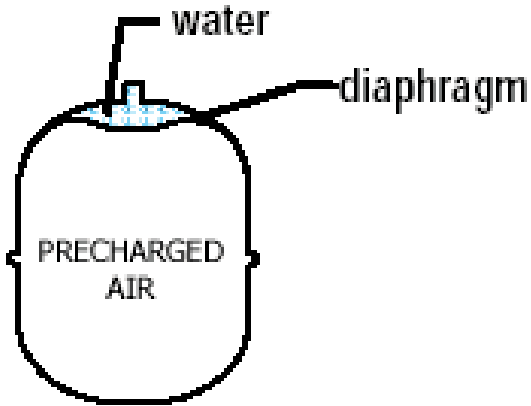

System **On**

System Pressure=14

Tank Pressure=14

Normal Tank Operation

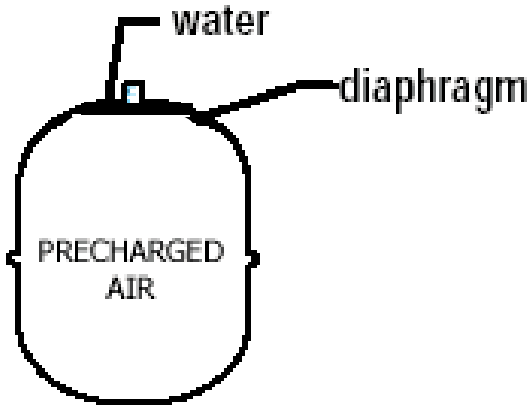

System Off

System
Pressure=12

Tank Pressure=12

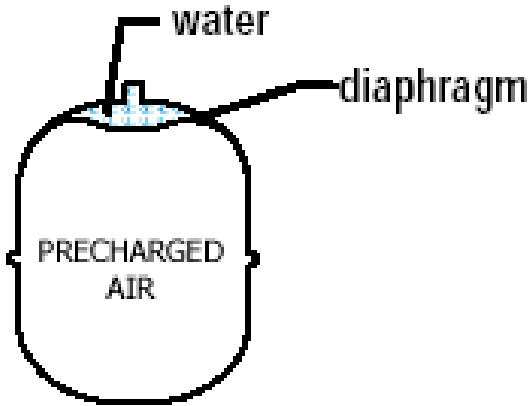

System On

System
Pressure=14

Tank Pressure=14

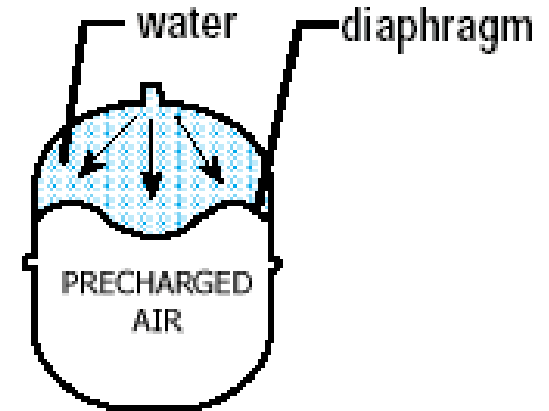

System On

System
Pressure=18

Tank Pressure=18

What happens if I don't Pump Up my Tank?

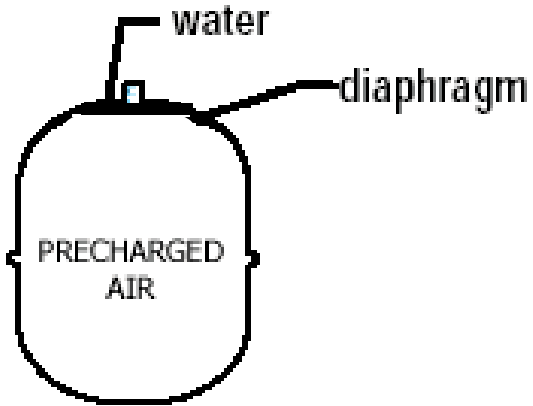

System Off

System Pressure=12

Tank Pressure=12

What happens if I don't Pump Up my Tank?

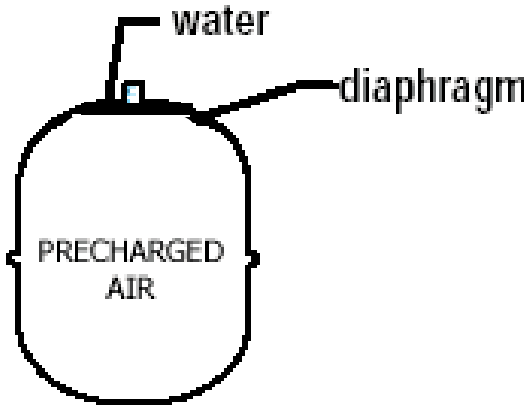

System Off

System Pressure=12

Tank Pressure=12

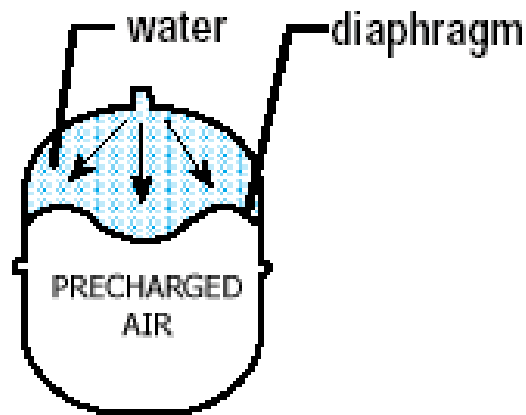

System Off

System Pressure Increased to 20

**(Tank Fills until air is
Compressed to match)**

Tank Pressure=20

What happens if I don't Pump Up my Tank?

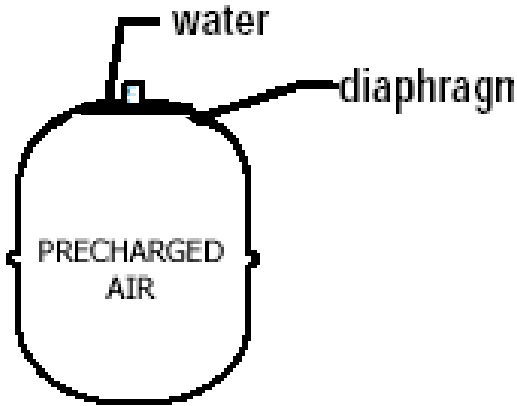

System Off

System Pressure=12

Tank Pressure=12

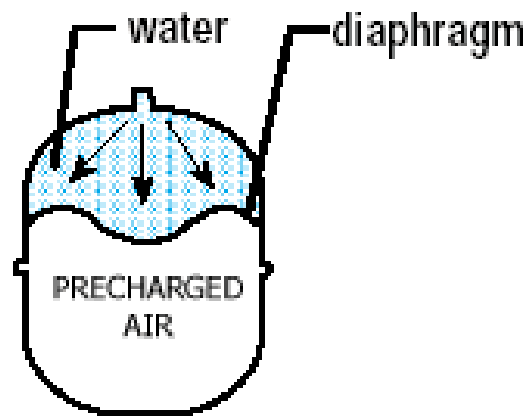

System Off

System Pressure=20

**(Tank Fills until air is
Compressed to
match)**

Tank Pressure=20

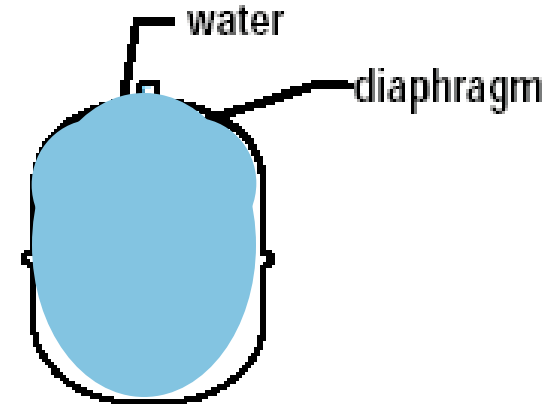

System **On**- Pressure
Increases due to
Expansion

System Pressure=



Tank =FULL!

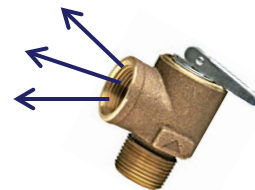
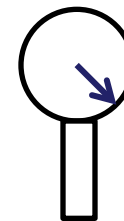

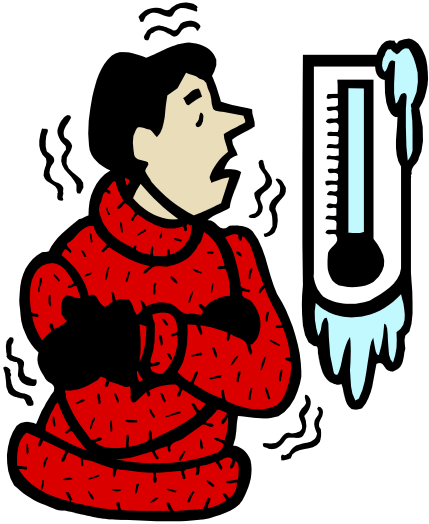

- Antifreeze is more viscous. Pump capacity reduced.
- Thermal transfer capability reduced 17% at 50-50 strength.
- Only use what's necessary.
- Use tester to determine proper level.
- Don't mix & match
- Future Service / Acidic

- 15 Year ECR Limited Warranty
- One Year all other parts
- First Year Leak Warranty

The SSV heat exchanger is simply the finest ever designed and as such we provide the strongest factory warranty available. An additional first year leak-free heat exchanger coverage provides the original purchaser the right to select a new replacement SSV boiler or heat exchanger at their choice, and receive a labor allowance of \$500.00 for the servicing contractor.





There are some things you can always depend on...

Utica Boilers has been a trusted supplier of gas and oil-fired boilers for residential and commercial buildings since 1928. Contractors and homeowners alike choose Utica Boilers as their preferred supplier because of our high efficiencies, easy maintenance and installation features, and limited lifetime warranties.

Our line of products are designed, tested, and assembled to ensure that our customers get the very best in home heating comfort and value. The complete selection of gas and oil-fired products only use superior parts and has earned a reputation for exceptional quality, performance, and dependability since its inception. Our testing standards are second to none and are supplemented by a computerized process that tracks components to finished goods. Utica's highly trained and skilled workforce ensures every customer that our products and service are among the best in the industry.

Utica products offer:

- Innovative, dependable designs made right here in America
- Solid reliability
- Highest quality parts
- Best-in-class warranties
- Responsive and adaptive service professionals

SSC STAINLESS STEEL CONDENSING Wall hung modulating condensing boiler



Most Efficient

Thank You!



1-800-253-7900