

# Trade Price Book Addendum

Effective 5/1/2017



Utica Boilers Gas & Oil Fired Boilers

## Customer Service Technical Support

Phone: 800-325-5479  
Fax: 315-724-9319/866-432-7329  
[www.utica boilers.com](http://www.utica boilers.com)

## Corporate Sales

Phone: 877-386-5475  
Fax: 716-366-4670

## Literature

[literature@ecrinternational.com](mailto:literature@ecrinternational.com)



**ECR** international  
EST. 1928

A Family of Heating & Cooling Brands.

P/N 240005093 Addendum

**UCS 240**

NATURAL OR PROPANE KIT  
 CONDENSING HOT WATER BOILER  
 WALL MOUNT OR FLOOR BASE  
 6.7:1 TURNDOWN RATIO

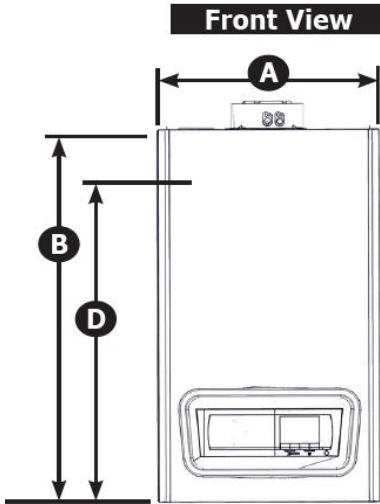
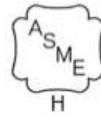

**Bottom View Dimensions**

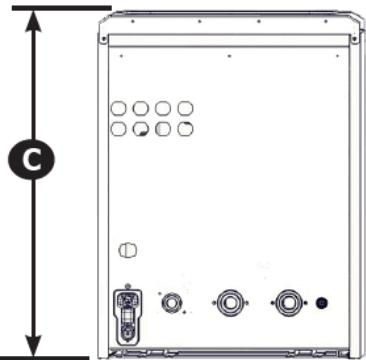

The UCS 240 has an AFUE of 95% and meets the criteria for 2017 Most Efficient.



**General Information** (See IOM for complete instructions)

Clearances	Combustible Materials (Required) (1)		Service (2)
	1) Required distances measured from boiler jacket.	Top	0" (0 mm)
Left Side		1-3/4" (45 mm)	1-3/4" (45 mm)
Right Side		1-3/4" (45 mm)	1-3/4" (45 mm)
Front		2" (51 mm)	17-3/4" (450 mm)
Back		0" (0 mm)	0" (0 mm)
Bottom		0" (0 mm)	*9-7/8" (250 mm)
(2) Service, proper operation clearance recommended. (*) Allowance for Piping at the bottom of boiler not included	Combustion Air/Vent Piping	0" (0 mm)	6" (160 mm)

<b>Connections UCS-240</b>	Gas Connection 3/4" NPT 1" NPT Heating System Supply & Return (without manifold) 1-1/2" Copper Stub Heating System Supply & Return (with manifold)
----------------------------	--

<b>Water Content</b>	0.8 Gallons
----------------------	-------------

**Note: Refer to IOM and vent pipe manufacturer's instructions for equivalent vent lengths and alternate venting materials.**

<b>Electrical</b>	120 Volts AC, 60 hertz, 1 phase, Less than 12 amps (15 amp circuit recommended)
-------------------	---

<b>Shipping Weight</b>	145 lbs. (65.8kg)
------------------------	-------------------

Dimensions	
Model 240 - Physical Data	
Width "A"	17 - 3/4"
	450 mm
Height "B"	31 - 1/16"
	763 mm
Depth "C"	23"
	585 mm
Bracket on Back "D"	15 - 7/8"
	403.2 mm





UCS 240 CONTINUED								
(NATURAL GAS - LESS PRIMARY PUMP)								
BOILER MODEL	ITEM NUMBER	TRADE PRICE	INPUT RATE (MBH)	HTG. CAP. (MBH)	NET RATING WATER (MBH)	AFUE RATING %	VENTING COAXIAL	VENTING 2-PIPE
UCS-240	UCS124000600110	\$7,500	241,000	216,000	188,000	95	3" / 5"	3"
UCS 240 CONTINUED								
UCS 240 - VENTING OPTIONS/ADDITIONAL EQUIPMENT (USE PARTS MULTIPLIER)					PN	TRADE		
MANUAL RESET HIGH LIMIT KIT L4006E1109					550003322	\$235		
MANUAL RESET LWCO KIT					550003323	\$225		
CSD-1 KIT (INCLUDES HIGH LIMIT AND MANUAL RESET LWCO)					550003332	\$460		
COMMON VENTING CHECK VALVE KIT					550003354	\$330		
LP CONVERSION KIT					550003316	\$150		
OUTDOOR AIR SENSOR					BD710487302V	\$32		
DHW SENSOR KIT					550003189	\$70		
FLOOR BASE KIT					550003304	\$465		
UCS 240 - STANDARD EQUIPMENT								
<b>STANDARD EQUIPMENT:</b>								
<ul style="list-style-type: none"> <li>-Boiler Control Module: High Limit/Electronic Ignition Control.</li> <li>-User Display Interface: Digital Temperature Display with diagnostics and programmable settings.</li> <li>-Heat Exchanger: 316L Stainless Steel</li> <li>-Combustion: 6.7:1 Turndown, Stainless Steel Burner, Direct Spark Ignition, Combination Flame Sensor and Ignitor</li> <li>-Other: Assembled Boiler with Jacket, Built-In Boiler Loop Pump, 50 psi Relief Valve Low Water Pressure Sensor, Temperature/Pressure Gauge</li> </ul> <p>Optional: Outdoor Temperature Sensor, Indirect Tank Sensor, Floor Base Kit, CSD-1 Kits available (includes Manual Reset Low Water Cut Off as well as High Limit.).</p>								

\* Vent accessories listed on the next page.







**(USE PARTS MULTIPLIER FOR ALL OF THE FOLLOWING)**

**UCS 240 VENTING MATERIALS**

**COAXIAL VENTING**

<b>VENTING COAXIAL</b>	<b>DESCRIPTION</b>	<b>ITEM</b>	<b>TRADE PRICE</b>
	Coaxial Pipe 3.28' (1m) Long	KHG714088512	\$52
	Coaxial 90 Elbows	KHG714088712	\$28
	Coaxial 45 Elbows	KHG714088812	\$28
	Horizontal Vent Termination	KHG714088911	\$59
	Vertical Vent Termination	KHG714093512	\$83

**TWIN PIPE POLYPROPYLENE VENTING**

<b>POLYPROPYLENE VENTING</b>	<b>DESCRIPTION</b>	<b>ITEM</b>	<b>TRADE PRICE</b>
	Boiler Appliance Twin Pipe Adapters For Polypropylene	KHG714089010	\$36
	Polypropylene Pipe 3.28' (1m) Long	KUG714132610	\$15
	Polypropylene 90 Elbows	KUG714132410	\$10
	Polypropylene 45 Elbows	KUG714132310	\$10
	Horizontal Vent Termination	KUG714132010	\$17
	Vertical Vent Termination	KUG714132110	\$43

**TWIN PIPE CPVC UL1738 / S636 VENTING ADAPTER KIT**

<b>DESCRIPTION</b>	<b>ITEM</b>	<b>TRADE PRICE</b>	
	Boiler Appliance Twin Pipe Adapter Kit For 3" CPVC UL1738 / S636	550003403	\$100

**UCS 380**

NATURAL OR PROPANE KIT  
 CONDENSING HOT WATER BOILER  
 FLOOR STANDING BOILER  
 10.5:1 TURNDOWN RATIO

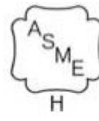

**Front View**

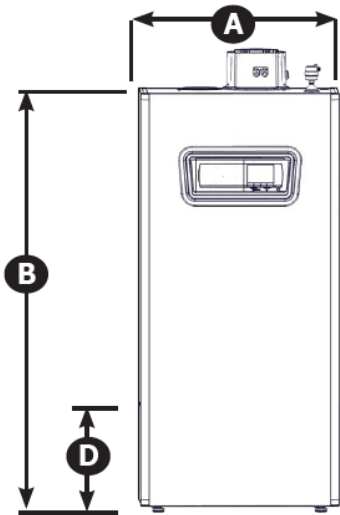

**Bottom View Dimensions**

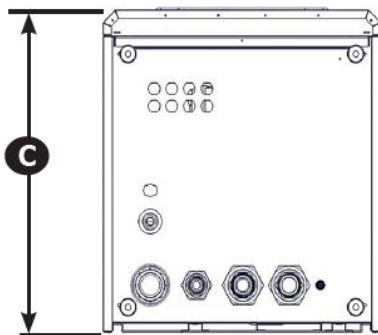

The UCS 380 has a Thermal Efficiency of 95%.



**General Information** (See IOM for complete instructions)

Clearances	Combustible Materials (Required) (1)	Service (2)	
1) Required distances measured from boiler jacket.	Top	0" (0 mm)	15-3/4" (400 mm)
	Left Side	1-3/4" (45 mm)	1-3/4" (45 mm)
	Right Side	1-3/4" (45 mm)	1-3/4" (45 mm)
	Front	2" (51 mm)	23-5/8" (600 mm)
	Back	0" (0 mm)	0" (0 mm)
	Bottom	0" (0 mm)	0" (0 mm)
(2) Service, proper operation clearance recommended.	Combustion Air/Vent Piping	0" (0 mm)	6" (160 mm)

<b>Connections UCS-380</b>	Gas Connection 1" NPT 1-1/2" NPT Heating System Supply & Return (without manifold) 1-1/2" Copper Stub Heating System Supply & Return (with manifold)
----------------------------	--

<b>Water Content</b>	4.6 Gallons
----------------------	-------------

**Note: Refer to IOM and vent pipe manufacturer's instructions for equivalent vent lengths and alternate venting materials.**

<b>Electrical</b>	120 Volts AC, 60 hertz, 1 phase, Less than 12 amps (15 amp circuit recommended)
-------------------	---

<b>Shipping Weight</b>	255 lbs. (115.7kg)
------------------------	--------------------

Dimensions	
Model 380 - Physical Data	
Width "A"	23 - 5/8"
	600 mm
Height "B"	50"
	1270 mm
Depth "C"	23 - 1/2"
	648 mm
Bracket on Back "D"	11 - 3/4"
	298.5 mm

UCS 380 CONTINUED								
(NATURAL GAS - LESS PRIMARY PUMP)								
BOILER MODEL	ITEM NUMBER	TRADE PRICE	INPUT RATE (MBH)	HTG. CAP. (MBH)	NET RATING WATER (MBH)	THERMAL EFF. %	VENTING COAXIAL	VENTING 2-PIPE
UCS-380	UCS138000600110	\$9,475	379,000	348,000	303,000	95	4" / 6"	4"

**UCS 380 CONTINUED**

UCS 380 - VENTING OPTIONS/ADDITIONAL EQUIPMENT (USE PARTS MULTIPLIER)			PN	TRADE
MANUAL RESET HIGH LIMIT KIT L4006E1109			550003322	\$235
MANUAL RESET LWCO KIT			550003323	\$225
CSD-1 KIT (INCLUDES HIGH LIMIT AND MANUAL RESET LWCO)			550003332	\$460
COMMON VENTING CHECK VALVE KIT			550003354	\$330
LP CONVERSION KIT			550003317	\$150
OUTDOOR AIR SENSOR			BD710487302V	\$32
DHW SENSOR KIT			550003189	\$70

**UCS 380 - STANDARD EQUIPMENT**

**STANDARD EQUIPMENT:**

- Boiler Control Module: High Limit/Electronic Ignition Control.
- User Display Interface: Digital Temperature Display with diagnostics and programmable settings.
- Heat Exchanger: 316L Stainless Steel
- Combustion: 10.5:1 Turndown, Stainless Steel Burner, Direct Spark Ignition, Combination Flame Sensor and Ignitor
- Other: Assembled Boiler with Jacket, Built-In Boiler Loop Pump, 50 psi Relief Valve Low Water Pressure Sensor, Temperature/Pressure Gauge





Optional: Outdoor Temperature Sensor, Indirect Tank Sensor, Floor Base Kit, CSD-1 Kits available (includes Manual Reset Low Water Cut Off as well as High Limit.).

\* Vent accessories listed on the next page.







**(USE PARTS MULTIPLIER FOR ALL OF THE FOLLOWING)**

**UCS 380 VENTING MATERIALS**

**COAXIAL VENTING**

<b>VENTING COAXIAL</b>	<b>DESCRIPTION</b>	<b>ITEM</b>	<b>TRADE PRICE</b>
	Coaxial Pipe 3.28' (1m) Long	KUG714133833	\$90
	Coaxial 90 Elbows	KUG714133611	\$77
	Coaxial 45 Elbows	KUG714133511	\$77
	Horizontal Vent Termination	KUG714133311	\$218
	Vertical Vent Termination	KUG714133411	\$278

**TWIN PIPE POLYPROPYLENE VENTING**

<b>POLYPROPYLENE VENTING</b>	<b>DESCRIPTION</b>	<b>ITEM</b>	<b>TRADE PRICE</b>
	Boiler Appliance Twin Pipe Adapters For 4" UL1738 / S636	BD7106314V	\$118
	Polypropylene Pipe 3.28' (1m) Long	KUG714133210	\$30
	Polypropylene 90 Elbows	KUG714133010	\$19
	Polypropylene 45 Elbows	KUG714132910	\$19
	Horizontal Vent Termination	KUG714132710	\$111
	Vertical Vent Termination	KUG714132810	\$101





**(NATURAL GAS - LESS SYSTEM PUMP - HYDROLEVEL CONTROL)**

BOILER MODEL	ITEM NUMBER	TRADE PRICE	INPUT (MBH)	HTG. CAP. (MBH)	AHRI NET (MBH)	AFUE RATING %	AIR CUSHION TANK	NO. OF BRNS.	SHIP WGT.
MGB-50J	MGB205003200210	\$2,059	50	52	37	83.5	15	1	205
MGB-75J	MGB307503200210	\$2,313	75	63	55	83.1	15	2	253
MGB-100J	MGB310003200210	\$2,393	100	83	72	83.0	30	2	253
MGB-125J	MGB412503200210	\$2,616	125	104	90	82.0	30	3	315
MGB-150J	MGB415003200210	\$2,702	150	124	108	83.0	30	3	315
MGB-170J	MGB517003200210	\$3,199	170	139	121	82.0	30	4	377
MGB-200J	MGB520003200210	\$3,381	200	165	143	82.0	30	4	377
MGC-8D	MGC826203200210	\$3,999	262.5	220	191	83.9	60	7	552
MGC-9D	MGC929903200210	\$4,600	299	251	218	83.7	60	8	616

**(NATURAL GAS - WITH GRUNDFOS SYSTEM PUMP - HYDROLEVEL CONTROL)**

BOILER MODEL	ITEM NUMBER	TRADE PRICE	INPUT (MBH)	HTG. CAP. (MBH)	AHRI NET (MBH)	AFUE RATING %	AIR CUSHION TANK	NO. OF BRNS.	SHIP WGT.
MGB-50J	MGB205003220210	\$2,135	50	52	37	83.5	15	1	205
MGB-75J	MGB307503220210	\$2,389	75	63	55	83.1	15	2	253
MGB-100J	MGB310003220210	\$2,469	100	83	72	83.0	30	2	253
MGB-125J	MGB412503220210	\$2,692	125	104	90	82.0	30	3	315
MGB-150J	MGB415003220210	\$2,778	150	124	108	83.0	30	3	315
MGB-170J	MGB517003220210	\$3,275	170	139	121	82.0	30	4	377
MGB-200J	MGB520003220210	\$3,457	200	165	143	82.0	30	4	377
MGC-8D	MGC826203220210	\$4,075	262.5	220	191.0	83.9	60	7	552
MGC-9D	MGC929903220210	\$4,676	299	251	218.0	83.7	60	8	616

**(NATURAL GAS, HIGH ALTITUDE - WITH GRUNDFOS SYSTEM PUMP - HYDROLEVEL CONTROL)**

BOILER MODEL	ITEM NUMBER	TRADE PRICE	INPUT (MBH)	HTG. CAP. (MBH)	AHRI NET (MBH)	AFUE RATING %	AIR CUSHION TANK	NO. OF BRNS.	SHIP WGT.
MGB-50J	MGB205003222210	\$2,135	50	52	37	83.5	15	1	205
MGB-75J	MGB307503222210	\$2,389	75	63	55	83.1	15	2	253
MGB-100J	MGB310003222210	\$2,469	100	83	72	83.0	30	2	253
MGB-125J	MGB412503222210	\$2,692	125	104	90	82.0	30	3	315
MGB-150J	MGB415003222210	\$2,778	150	124	108	83.0	30	3	315
MGB-170J	MGB517003222210	\$3,275	170	139	121	82.0	30	4	377
MGB-200J	MGB520003222210	\$3,457	200	165	143	82.0	30	4	377

**(NATURAL GAS - WITH B & G SYSTEM PUMP - HYDROLEVEL CONTROL)**

BOILER MODEL	ITEM NUMBER	TRADE PRICE	INPUT (MBH)	HTG. CAP. (MBH)	AHRI NET (MBH)	AFUE RATING %	AIR CUSHION TANK	NO. OF BRNS.	SHIP WGT.
MGB-50J	MGB205003230210	\$2,135	50	52	37	83.5	15	1	205
MGB-75J	MGB307503230210	\$2,389	75	63	55	83.1	15	2	253
MGB-100J	MGB310003230210	\$2,469	100	83	72	83.0	30	2	253
MGB-125J	MGB412503230210	\$2,692	125	104	90	82.0	30	3	315
MGB-150J	MGB415003230210	\$2,778	150	124	108	83.0	30	3	315
MGB-170J	MGB517003230210	\$3,275	170	139	121	82.0	30	4	377
MGB-200J	MGB520003230210	\$3,457	200	165	143	82.0	30	4	377

(NATURAL GAS - WITH TACO ECM SYSTEM PUMP - HYDROLEVEL CONTROL)									
BOILER MODEL	ITEM NUMBER	TRADE PRICE	INPUT (MBH)	HTG. CAP. (MBH)	AHRI NET (MBH)	AFUE RATING %	AIR CUSHION TANK	NO. OF BRNS.	SHIP WGT.
MGB-50J	MGB205003240210	\$2,135	50	52	37	83.5	15	1	205
MGB-75J	MGB307503240210	\$2,389	75	63	55	83.1	15	2	253
MGB-100J	MGB310003240210	\$2,469	100	83	72	83.0	30	2	253
MGB-125J	MGB412503240210	\$2,692	125	104	90	82.0	30	3	315
MGB-150J	MGB415003240210	\$2,778	150	124	108	83.0	30	3	315
MGB-170J	MGB517003240210	\$3,275	170	139	121	82.0	30	4	377
MGB-200J	MGB520003240210	\$3,457	200	165	143	82.0	30	4	377
MGC-8D	MGC826203240210	\$4,075	262.5	220	191.0	83.9	60	7	552
MGC-9D	MGC929903240210	\$4,676	299	251	218.0	83.7	60	8	616
(LP GAS - WITH GRUNDFOS SYSTEM PUMP - HYDROLEVEL CONTROL)									
BOILER MODEL	ITEM NUMBER	TRADE PRICE	INPUT (MBH)	HTG. CAP. (MBH)	AHRI NET (MBH)	AFUE RATING %	AIR CUSHION TANK	NO. OF BRNS.	SHIP WGT.
MGB-50J	MGB205013220210	\$2,187	50	52	37	83.5	15	1	205
MGB-75J	MGB307513220210	\$2,441	75	63	55	83.1	15	2	253
MGB-100J	MGB310013220210	\$2,521	100	83	72	83.0	30	2	253
MGB-125J	MGB412513220210	\$2,744	125	104	90	82.0	30	3	315
MGB-150J	MGB415013220210	\$2,830	150	124	108	83.0	30	3	315
MGB-170J	MGB517013220210	\$3,327	170	139	121	82.0	30	4	377
MGB-200J	MGB520013220210	\$3,509	200	165	143	82.0	30	4	377
(LP GAS - WITH B & G SYSTEM PUMP - HYDROLEVEL CONTROL)									
BOILER MODEL	ITEM NUMBER	TRADE PRICE	INPUT (MBH)	HTG. CAP. (MBH)	AHRI NET (MBH)	AFUE RATING %	AIR CUSHION TANK	NO. OF BRNS.	SHIP WGT.
MGB-50J	MGB205013230210	\$2,187	50	52	37	83.5	15	1	205
MGB-75J	MGB307513230210	\$2,441	75	63	55	83.1	15	2	253
MGB-100J	MGB310013230210	\$2,521	100	83	72	83.0	30	2	253
MGB-125J	MGB412513230210	\$2,744	125	104	90	82.0	30	3	315
MGB-150J	MGB415013230210	\$2,830	150	124	108	83.0	30	3	315
MGB-170J	MGB517013230210	\$3,327	170	139	121	82.0	30	4	377
MGB-200J	MGB520013230210	\$3,509	200	165	143	82.0	30	4	377
(LP GAS - WITH TACO ECM SYSTEM PUMP - HYDROLEVEL CONTROL)									
BOILER MODEL	ITEM NUMBER	TRADE PRICE	INPUT (MBH)	HTG. CAP. (MBH)	AHRI NET (MBH)	AFUE RATING %	AIR CUSHION TANK	NO. OF BRNS.	SHIP WGT.
MGB-50J	MGB205013240210	\$2,187	50	52	37	83.5	15	1	205
MGB-75J	MGB307513240210	\$2,441	75	63	55	83.1	15	2	253
MGB-100J	MGB310013240210	\$2,521	100	83	72	83.0	30	2	253
MGB-125J	MGB412513240210	\$2,744	125	104	90	82.0	30	3	315
MGB-150J	MGB415013240210	\$2,830	150	124	108	83.0	30	3	315
MGB-170J	MGB517013240210	\$3,327	170	139	121	82.0	30	4	377
MGB-200J	MGB520013240210	\$3,509	200	165	143	82.0	30	4	377

(USE PARTS MULTIPLIER FOR ALL OF THE FOLLOWING)	PN	TRADE
COMBUSTIBLE FLOOR PLATE MGB-50J	325-2-8.01	\$212
COMBUSTIBLE FLOOR PLATE MGB-75J	325-2-8.02	\$222
COMBUSTIBLE FLOOR PLATE MBG-100J	325-2-8.02	\$222
COMBUSTIBLE FLOOR PLATE MGB-125J	325-2-8.03	\$244
COMBUSTIBLE FLOOR PLATE MGB-150J	325-2-8.03	\$244
COMBUSTIBLE FLOOR PLATE MGB-170J	325-2-8.04	\$244
COMBUSTIBLE FLOOR PLATE MGB-200J	325-2-8.04	\$244
COMBUSTIBLE FLOOR PLATE MGC-8D,8DP,9D,9DP	14614032	\$96
CONVERSION KIT NAT. TO LP MGB-50J	550002663	\$82
CONVERSION KIT NAT. TO LP MGB-75J	550002664	\$82
CONVERSION KIT NAT. TO LP MGB-100J	550002663	\$82
CONVERSION KIT NAT. TO LP MGB-125J	550002665	\$82
CONVERSION KIT NAT. TO LP MGB-150J	550002663	\$82
CONVERSION KIT NAT. TO LP MGB-170J	550002665	\$82
CONVERSION KIT NAT. TO LP MGB-200J	550002663	\$82
CONVERSION KIT NAT. TO LP MGC-8	43300728	\$59
CONVERSION KIT NAT. TO LP MGC-9	43300729	\$59
CONVERSION KIT LP TO NAT. MGB-50J	5611902	\$100
CONVERSION KIT LP TO NAT. MGB-75J	5611903	\$102
CONVERSION KIT LP TO NAT. MGB-100J	5611904	\$102
CONVERSION KIT LP TO NAT. MGB-125J	5611905	\$104
CONVERSION KIT LP TO NAT. MGB-150J	5611906	\$104
CONVERSION KIT LP TO NAT. MGB-170J	5611905	\$104
CONVERSION KIT LP TO NAT. MGB-200J	5611908	\$106
CONVERSION KIT LP TO NAT. MGC-8	43300636	\$130
CONVERSION KIT LP TO NAT. MGC-9	43300637	\$155
FILL-TROL #110 FOR WATER BOILERS 150 MBH OR LESS	14624002	\$291
FILL-TROL #111 FOR WATER BOILERS OVER 150 MBH	14624003	\$392

**MGB SERIES II & MGC SERIES STANDARD EQUIPMENT**

**STANDARD EQUIPMENT:**

- Boiler Control Module:  
Hydrolevel Fuel Smart Control (High Limit/LWCO)
- User Display Interface: Digital Temperature Display
- Heat Exchanger: Cast Iron Sections with Cast Iron Push Nipples.
- Combustion: Stainless Steel Main Gas Burners (MGB)/Titanium Composite Burners (MGC), Combination 24 Volt Gas Control (Includes: Automatic Gas Valve, Gas Pressure Regulator, Automatic Pilot, Safety Shutoff, Pilot Flow Adjustment, Pilot Filter), Intermittent Pilot Control, Continuous Retry, Combination Pilot Burner/Electrode/Flame Sensor.
- Safety: Spill Switch and Roll-Out Switch for safety (MGB)/Flame Roll-Out Safety Shut-Off (Fuse Link) (MGC), Automatic Vent Damper.
- Other: Insulated Boiler Jacket, Integral Draft Diverter, Combination Temperature/Pressure Gauge, Circulator Pump, 3/4" Drain Valve, 30lb. ASME Relief Valve.

**STARFIRE SFH-IV SERIES**  
OIL CHIMNEY VENT  
WATER BOILER

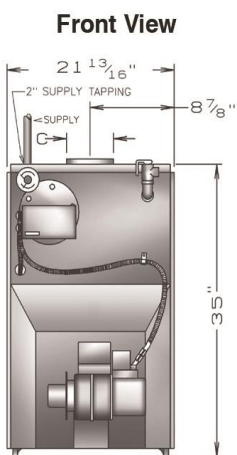
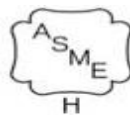

**General Information** (See IOM for complete instructions)

<b>Clearances</b>		<b>Combustible Materials (Required) (1)</b>
<b>(1) Required distances measured from boiler.</b>	<b>Top</b>	24" (610 mm)
	<b>Front</b>	24" (610 mm)
	<b>Flue Connector</b>	9" (229 mm)
	<b>Rear</b>	6" (152 mm)
	<b>Sides</b>	6" (152 mm)
<b>Connections</b>	Supply Tapping - 2", Return Tapping 1-1/2" NPT, Oil Line 3/8" O.D. copper tubing for runs of 50 feet or less, and 1/2" O.D. for longer runs.	
<b>All Models</b>		
<b>Electrical</b>	120 Volts AC, 60 hertz, 1 phase, Less than 12 amps (15 amp circuit recommended)	
<b>Water Content</b>	SFH3 - 10.5 Gallons, SFH4 - 13.5 Gallons, SFH5 - 16.5 Gallons, SFH6 - 19.5 Gallons	

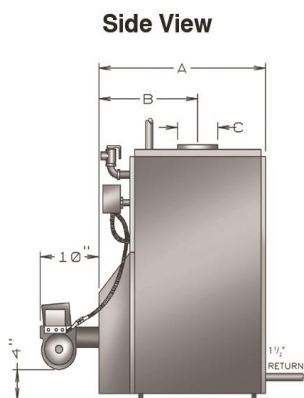

Model	Input Rate G.P.H.	Tankless Heater Number	Tankless Heater Cap. Intermittent
SFH-3085WT	0.85	T3	3
SFH-3100WT	1.00	T3	3.25
SFH-4100WT	1.00	T4	3.25
SFH-4125WT	1.25	T4	3.75
SFH-4145WT	1.45	T4	4
SFH-5160WT	1.60	T4	4
SFH-5185WT	1.85	T4	4.25
SFH-6175WT	1.75	T4	4.25
SFH-6210WT	2.10	T4	4.5

**Dimensions**

Number of Sections	A (Depth of Flush Jacket)	B (Front of Jacket to Center Line of Flue)	C (Flue Outlet Diam.)
3	17-7/8"	11-1/4"	6"
4	21-1/2"	12-5/8"	6"
5	25-1/8"	14-1/4"	7"
6	29-1/4"	15-15/16"	8"

<b>(BECKETT BURNER - CHIMNEY VENTED - LESS PUMP - HYDROLEVEL CONTROL - CAST OVER)</b>									
<b>BOILER MODEL</b>	<b>ITEM NUMBER</b>	<b>TRADE PRICE</b>	<b>NO. OF SEC.</b>	<b>INPUT (MBH)</b>	<b>HTG. CAP. (MBH)</b>	<b>AHRI NET (MBH)</b>	<b>FIRING RATE G.P.H.</b>	<b>AFUE RATING %</b>	<b>SHIP WGT.</b>
SFH-3085W	SFH308530200410	\$3,287	3	119	103	90	0.85	85.0	534
SFH-3100W	SFH310030200410	\$3,287	3	140	119	103	1.00	84.0	534
SFH-4100W	SFH410030200410	\$3,768	4	140	122	106	1.00	86.0	668
SFH-4125W	SFH412530200410	\$3,768	4	175	151	131	1.25	85.0	668
SFH-4145W	SFH414530200410	\$3,768	4	203	173	150	1.45	84.0	668
SFH-5160W	SFH516030200410	\$4,284	5	224	193	168	1.60	85.0	781
SFH-5185W	SFH518530200410	\$4,284	5	259	221	192	1.85	84.0	781
SFH-6175W	SFH617530200410	\$4,692	6	245	212	184	1.75	85.0	901
SFH-6210W	SFH621030200410	\$4,692	6	294	252	219	2.10	84.0	901
<b>(BECKETT BURNER - CHIMNEY VENTED - TACO SYSTEM PUMP - HYDROLEVEL CONTROL - CAST OVER)</b>									
<b>BOILER MODEL</b>	<b>ITEM NUMBER</b>	<b>TRADE PRICE</b>	<b>NO. OF SEC.</b>	<b>INPUT (MBH)</b>	<b>HTG. CAP. (MBH)</b>	<b>AHRI NET (MBH)</b>	<b>FIRING RATE G.P.H.</b>	<b>AFUE RATING %</b>	<b>SHIP WGT.</b>
SFH-3085W	SFH308530210410	\$3,364	3	119	103	90	0.85	85.0	534
SFH-3100W	SFH310030210410	\$3,364	3	140	119	103	1.00	84.0	534
SFH-4100W	SFH410030210410	\$3,845	4	140	122	106	1.00	86.0	668
SFH-4125W	SFH412530210410	\$3,845	4	175	151	131	1.25	85.0	668
SFH-4145W	SFH414530210410	\$3,845	4	203	173	150	1.45	84.0	668
SFH-5160W	SFH516030210410	\$4,361	5	224	193	168	1.60	85.0	781
SFH-5185W	SFH518530210410	\$4,361	5	259	221	192	1.85	84.0	781
SFH-6175W	SFH617530210410	\$4,769	6	245	212	184	1.75	85.0	901
SFH-6210W	SFH621030210410	\$4,769	6	294	252	219	2.10	84.0	901
<b>(BECKETT BURNER - CHIMNEY VENTED - GRUNDFOS SYSTEM PUMP - HYDROLEVEL CONTROL - CAST OVER)</b>									
<b>BOILER MODEL</b>	<b>ITEM NUMBER</b>	<b>TRADE PRICE</b>	<b>NO. OF SEC.</b>	<b>INPUT (MBH)</b>	<b>HTG. CAP. (MBH)</b>	<b>AHRI NET (MBH)</b>	<b>FIRING RATE G.P.H.</b>	<b>AFUE RATING %</b>	<b>SHIP WGT.</b>
SFH-3085W	SFH308530220410	\$3,364	3	119	103	90	0.85	85.0	534
SFH-3100W	SFH310030220410	\$3,364	3	140	119	103	1.00	84.0	534
SFH-4100W	SFH410030220410	\$3,845	4	140	122	106	1.00	86.0	668
SFH-4125W	SFH412530220410	\$3,845	4	175	151	131	1.25	85.0	668
SFH-4145W	SFH414530220410	\$3,845	4	203	173	150	1.45	84.0	668
SFH-5160W	SFH516030220410	\$4,361	5	224	193	168	1.60	85.0	781
SFH-5185W	SFH518530220410	\$4,361	5	259	221	192	1.85	84.0	781
SFH-6175W	SFH617530220410	\$4,769	6	245	212	184	1.75	85.0	901
SFH-6210W	SFH621030220410	\$4,769	6	294	252	219	2.10	84.0	901

(BECKETT BURNER - CHIMNEY VENTED - LESS PUMP - HYDROLEVEL - WITH TANKLESS COVER PLATE)									
BOILER MODEL	ITEM NUMBER	TRADE PRICE	NO. OF SEC.	INPUT (MBH)	HTG. CAP. (MBH)	AHRI NET (MBH)	FIRING RATE G.P.H.	AFUE RATING %	SHIP WGT.
SFH-3085W	SFH308531200410	\$3,409	3	119	103	90	0.85	85.0	534
SFH-3100W	SFH310031200410	\$3,409	3	140	119	103	1.00	84.0	534
SFH-4100W	SFH410031200410	\$3,902	4	140	122	106	1.00	86.0	668
SFH-4125W	SFH412531200410	\$3,902	4	175	151	131	1.25	85.0	668
SFH-4145W	SFH414531200410	\$3,902	4	203	173	150	1.45	84.0	668
SFH-5160W	SFH516031200410	\$4,427	5	224	193	168	1.60	85.0	781
SFH-5185W	SFH518531200410	\$4,427	5	259	221	192	1.85	84.0	781
SFH-6175W	SFH617531200410	\$4,844	6	245	212	184	1.75	85.0	901
SFH-6210W	SFH621031200410	\$4,844	6	294	252	219	2.10	84.0	901
(BECKETT BURNER - CHIMNEY VENTED - TACO PUMP - HYDROLEVEL - WITH TANKLESS COVER PLATE)									
BOILER MODEL	ITEM NUMBER	TRADE PRICE	NO. OF SEC.	INPUT (MBH)	HTG. CAP. (MBH)	AHRI NET (MBH)	FIRING RATE G.P.H.	AFUE RATING %	SHIP WGT.
SFH-3085W	SFH308531210410	\$3,487	3	119	103	90	0.85	85.0	534
SFH-3100W	SFH310031210410	\$3,487	3	140	119	103	1.00	84.0	534
SFH-4100W	SFH410031210410	\$3,979	4	140	122	106	1.00	86.0	668
SFH-4125W	SFH412531210410	\$3,979	4	175	151	131	1.25	85.0	668
SFH-4145W	SFH414531210410	\$3,979	4	203	173	150	1.45	84.0	668
SFH-5160W	SFH516031210410	\$4,505	5	224	193	168	1.60	85.0	781
SFH-5185W	SFH518531210410	\$4,505	5	259	221	192	1.85	84.0	781
SFH-6175W	SFH617531210410	\$4,921	6	245	212	184	1.75	85.0	901
SFH-6210W	SFH621031210410	\$4,921	6	294	252	219	2.10	84.0	901
(BECKETT BURNER - CHIMNEY VENTED - GRUNDFOS PUMP - HYDROLEVEL - WITH TANKLESS COVER PLATE)									
BOILER MODEL	ITEM NUMBER	TRADE PRICE	NO. OF SEC.	INPUT (MBH)	HTG. CAP. (MBH)	AHRI NET (MBH)	FIRING RATE G.P.H.	AFUE RATING %	SHIP WGT.
SFH-3085W	SFH308531220410	\$3,487	3	119	103	90	0.85	85.0	534
SFH-3100W	SFH310031220410	\$3,487	3	140	119	103	1.00	84.0	534
SFH-4100W	SFH410031220410	\$3,979	4	140	122	106	1.00	86.0	668
SFH-4125W	SFH412531220410	\$3,979	4	175	151	131	1.25	85.0	668
SFH-4145W	SFH414531220410	\$3,979	4	203	173	150	1.45	84.0	668
SFH-5160W	SFH516031220410	\$4,505	5	224	193	168	1.60	85.0	781
SFH-5185W	SFH518531220410	\$4,505	5	259	221	192	1.85	84.0	781
SFH-6175W	SFH617531220410	\$4,921	6	245	212	184	1.75	85.0	901
SFH-6210W	SFH621031220410	\$4,921	6	294	252	219	2.10	84.0	901
(BECKETT BURNER - CHIMNEY VENTED - LESS PUMP - HYDROLEVEL - WITH TANKLESS COIL)									
BOILER MODEL	ITEM NUMBER	TRADE PRICE	NO. OF SEC.	INPUT (MBH)	HTG. CAP. (MBH)	AHRI NET (MBH)	FIRING RATE G.P.H.	AFUE RATING %	SHIP WGT.
SFH-3085WT	SFH308532200410	\$3,561	3	119	103	90	0.85	85.0	534
SFH-3100WT	SFH310032200410	\$3,561	3	140	119	103	1.00	84.0	534
SFH-4100WT	SFH410032200410	\$4,096	4	140	122	106	1.00	86.0	668
SFH-4125WT	SFH412532200410	\$4,096	4	175	151	131	1.25	85.0	668
SFH-4145WT	SFH414532200410	\$4,096	4	203	173	150	1.45	84.0	668
SFH-5160WT	SFH516032200410	\$4,572	5	224	193	168	1.60	85.0	781
SFH-5185WT	SFH518532200410	\$4,572	5	259	221	192	1.85	84.0	781
SFH-6175WT	SFH617532200410	\$4,974	6	245	212	184	1.75	85.0	901
SFH-6210WT	SFH621032200410	\$4,974	6	294	252	219	2.10	84.0	901

<b>(BECKETT BURNER - CHIMNEY VENTED - TACO PUMP - HYDROLEVEL - WITH TANKLESS COIL)</b>									
<b>BOILER MODEL</b>	<b>ITEM NUMBER</b>	<b>TRADE PRICE</b>	<b>NO. OF SEC.</b>	<b>INPUT (MBH)</b>	<b>HTG. CAP. (MBH)</b>	<b>AHRI NET (MBH)</b>	<b>FIRING RATE G.P.H.</b>	<b>AFUE RATING %</b>	<b>SHIP WGT.</b>
SFH-3085WT	SFH308532210410	\$3,638	3	119	103	90	0.85	85.0	534
SFH-3100WT	SFH310032210410	\$3,638	3	140	119	103	1.00	84.0	534
SFH-4100WT	SFH410032210410	\$4,173	4	140	122	106	1.00	86.0	668
SFH-4125WT	SFH412532210410	\$4,173	4	175	151	131	1.25	85.0	668
SFH-4145WT	SFH414532210410	\$4,173	4	203	173	150	1.45	84.0	668
SFH-5160WT	SFH516032210410	\$4,649	5	224	193	168	1.60	85.0	781
SFH-5185WT	SFH518532210410	\$4,649	5	259	221	192	1.85	84.0	781
SFH-6175WT	SFH617532210410	\$5,051	6	245	212	184	1.75	85.0	901
SFH-6210WT	SFH621032210410	\$5,051	6	294	252	219	2.10	84.0	901
<b>(BECKETT BURNER - CHIMNEY VENTED - GRUNDFOS PUMP - HYDROLEVEL - WITH TANKLESS COIL)</b>									
<b>BOILER MODEL</b>	<b>ITEM NUMBER</b>	<b>TRADE PRICE</b>	<b>NO. OF SEC.</b>	<b>INPUT (MBH)</b>	<b>HTG. CAP. (MBH)</b>	<b>AHRI NET (MBH)</b>	<b>FIRING RATE G.P.H.</b>	<b>AFUE RATING %</b>	<b>SHIP WGT.</b>
SFH-3085WT	SFH308532220410	\$3,638	3	119	103	90	0.85	85.0	534
SFH-3100WT	SFH310032220410	\$3,638	3	140	119	103	1.00	84.0	534
SFH-4100WT	SFH410032220410	\$4,173	4	140	122	106	1.00	86.0	668
SFH-4125WT	SFH412532220410	\$4,173	4	175	151	131	1.25	85.0	668
SFH-4145WT	SFH414532220410	\$4,173	4	203	173	150	1.45	84.0	668
SFH-5160WT	SFH516032220410	\$4,649	5	224	193	168	1.60	85.0	781
SFH-5185WT	SFH518532220410	\$4,649	5	259	221	192	1.85	84.0	781
SFH-6175WT	SFH617532220410	\$5,051	6	245	212	184	1.75	85.0	901
SFH-6210WT	SFH621032220410	\$5,051	6	294	252	219	2.10	84.0	901
<b>(LESS BURNER - CHIMNEY VENTED - LESS PUMP - HYDROLEVEL CONTROL - CAST OVER)</b>									
<b>BOILER MODEL</b>	<b>ITEM NUMBER</b>	<b>TRADE PRICE</b>	<b>NO. OF SEC.</b>	<b>INPUT (MBH)</b>	<b>HTG. CAP. (MBH)</b>	<b>AHRI NET (MBH)</b>	<b>FIRING RATE G.P.H.</b>	<b>AFUE RATING %</b>	<b>SHIP WGT.</b>
SFH-3100W	SFH310020200410	\$2,459	3	140	119	103	1.00	84.0	534
SFH-4145W	SFH414520200410	\$2,900	4	203	173	150	1.45	84.0	668
SFH-5185W	SFH518520200410	\$3,402	5	259	221	192	1.85	84.0	781
SFH-6210W	SFH621020200410	\$3,794	6	294	252	219	2.10	84.0	901
<b>(LESS BURNER - CHIMNEY VENTED - TACO PUMP - HYDROLEVEL CONTROL - CAST OVER)</b>									
<b>BOILER MODEL</b>	<b>ITEM NUMBER</b>	<b>TRADE PRICE</b>	<b>NO. OF SEC.</b>	<b>INPUT (MBH)</b>	<b>HTG. CAP. (MBH)</b>	<b>AHRI NET (MBH)</b>	<b>FIRING RATE G.P.H.</b>	<b>AFUE RATING %</b>	<b>SHIP WGT.</b>
SFH-3100W	SFH310020210410	\$2,536	3	140	119	103	1.00	84.0	534
SFH-4145W	SFH414520210410	\$2,977	4	203	173	150	1.45	84.0	668
SFH-5185W	SFH518520210410	\$3,479	5	259	221	192	1.85	84.0	781
SFH-6210W	SFH621020210410	\$3,871	6	294	252	219	2.10	84.0	901
<b>(LESS BURNER - CHIMNEY VENTED - GRUNDFOS PUMP - HYDROLEVEL CONTROL - CAST OVER)</b>									
<b>BOILER MODEL</b>	<b>ITEM NUMBER</b>	<b>TRADE PRICE</b>	<b>NO. OF SEC.</b>	<b>INPUT (MBH)</b>	<b>HTG. CAP. (MBH)</b>	<b>AHRI NET (MBH)</b>	<b>FIRING RATE G.P.H.</b>	<b>AFUE RATING %</b>	<b>SHIP WGT.</b>
SFH-3100W	SFH310020220410	\$2,536	3	140	119	103	1.00	84.0	534
SFH-4145W	SFH414520220410	\$2,977	4	203	173	150	1.45	84.0	668
SFH-5185W	SFH518520220410	\$3,479	5	259	221	192	1.85	84.0	781
SFH-6210W	SFH621020220410	\$3,871	6	294	252	219	2.10	84.0	901

<b>(LESS BURNER - CHIMNEY VENTED - LESS PUMP - HYDROLEVEL CONTROL - WITH TANKLESS COVER PLATE)</b>									
<b>BOILER MODEL</b>	<b>ITEM NUMBER</b>	<b>TRADE PRICE</b>	<b>NO. OF SEC.</b>	<b>INPUT (MBH)</b>	<b>HTG. CAP. (MBH)</b>	<b>AHRI NET (MBH)</b>	<b>FIRING RATE G.P.H.</b>	<b>AFUE RATING %</b>	<b>SHIP WGT.</b>
SFH-3100W	SFH310021200410	\$2,582	3	140	119	103	1.00	84.0	534
SFH-4145W	SFH414521200410	\$3,034	4	203	173	150	1.45	84.0	668
SFH-5185W	SFH518521200410	\$3,545	5	259	221	192	1.85	84.0	781
SFH-6210W	SFH621021200410	\$3,945	6	294	252	219	2.10	84.0	901
<b>(LESS BURNER - CHIMNEY VENTED - TACO PUMP - HYDROLEVEL CONTROL - WITH TANKLESS COVER PLATE)</b>									
<b>BOILER MODEL</b>	<b>ITEM NUMBER</b>	<b>TRADE PRICE</b>	<b>NO. OF SEC.</b>	<b>INPUT (MBH)</b>	<b>HTG. CAP. (MBH)</b>	<b>AHRI NET (MBH)</b>	<b>FIRING RATE G.P.H.</b>	<b>AFUE RATING %</b>	<b>SHIP WGT.</b>
SFH-3100W	SFH310021210410	\$2,659	3	140	119	103	1.00	84.0	534
SFH-4145W	SFH414521210410	\$3,111	4	203	173	150	1.45	84.0	668
SFH-5185W	SFH518521210410	\$3,623	5	259	221	192	1.85	84.0	781
SFH-6210W	SFH621021210410	\$4,022	6	294	252	219	2.10	84.0	901
<b>(LESS BURNER - CHIMNEY VENTED - GRUNDFOS PUMP - HYDROLEVEL CONTROL - WITH TANKLESS COVER PLATE)</b>									
<b>BOILER MODEL</b>	<b>ITEM NUMBER</b>	<b>TRADE PRICE</b>	<b>NO. OF SEC.</b>	<b>INPUT (MBH)</b>	<b>HTG. CAP. (MBH)</b>	<b>AHRI NET (MBH)</b>	<b>FIRING RATE G.P.H.</b>	<b>AFUE RATING %</b>	<b>SHIP WGT.</b>
SFH-3100W	SFH310021220410	\$2,659	3	140	119	103	1.00	84.0	534
SFH-4145W	SFH414521220410	\$3,111	4	203	173	150	1.45	84.0	668
SFH-5185W	SFH518521220410	\$3,623	5	259	221	192	1.85	84.0	781
SFH-6210W	SFH621021220410	\$4,022	6	294	252	219	2.10	84.0	901
<b>(LESS BURNER - CHIMNEY VENTED - LESS PUMP - HYDROLEVEL - WITH TANKLESS COIL)</b>									
<b>BOILER MODEL</b>	<b>ITEM NUMBER</b>	<b>TRADE PRICE</b>	<b>NO. OF SEC.</b>	<b>INPUT (MBH)</b>	<b>HTG. CAP. (MBH)</b>	<b>AHRI NET (MBH)</b>	<b>FIRING RATE G.P.H.</b>	<b>AFUE RATING %</b>	<b>SHIP WGT.</b>
SFH-3100WT	SFH310022200410	\$2,733	3	140	119	103	1.00	84.0	534
SFH-4145WT	SFH414522200410	\$3,228	4	203	173	150	1.45	84.0	668
SFH-5185WT	SFH518522200410	\$3,690	5	259	221	192	1.85	84.0	781
SFH-6210WT	SFH621022200410	\$4,075	6	294	252	219	2.10	84.0	901
<b>(LESS BURNER - CHIMNEY VENTED - TACO PUMP - HYDROLEVEL - WITH TANKLESS COIL)</b>									
<b>BOILER MODEL</b>	<b>ITEM NUMBER</b>	<b>TRADE PRICE</b>	<b>NO. OF SEC.</b>	<b>INPUT (MBH)</b>	<b>HTG. CAP. (MBH)</b>	<b>AHRI NET (MBH)</b>	<b>FIRING RATE G.P.H.</b>	<b>AFUE RATING %</b>	<b>SHIP WGT.</b>
SFH-3100WT	SFH310022210410	\$2,811	3	140	119	103	1.00	84.0	534
SFH-4145WT	SFH414522210410	\$3,305	4	203	173	150	1.45	84.0	668
SFH-5185WT	SFH518522210410	\$3,767	5	259	221	192	1.85	84.0	781
SFH-6210WT	SFH621022210410	\$4,152	6	294	252	219	2.10	84.0	901
<b>(LESS BURNER - CHIMNEY VENTED - GRUNDFOS PUMP - HYDROLEVEL - WITH TANKLESS COIL)</b>									
<b>BOILER MODEL</b>	<b>ITEM NUMBER</b>	<b>TRADE PRICE</b>	<b>NO. OF SEC.</b>	<b>INPUT (MBH)</b>	<b>HTG. CAP. (MBH)</b>	<b>AHRI NET (MBH)</b>	<b>FIRING RATE G.P.H.</b>	<b>AFUE RATING %</b>	<b>SHIP WGT.</b>
SFH-3100WT	SFH310022220410	\$2,811	3	140	119	103	1.00	84.0	534
SFH-4145WT	SFH414522220410	\$3,305	4	203	173	150	1.45	84.0	668
SFH-5185WT	SFH518522220410	\$3,767	5	259	221	192	1.85	84.0	781
SFH-6210WT	SFH621022220410	\$4,152	6	294	252	219	2.10	84.0	901



<b>STARFIRE SFH-IV SERIES - OPTIONS/ADD. EQUIPMENT</b>	<b>PN</b>	<b>TRADE</b>
<b>3085/3011 BECKETT RERATE KIT</b> (Used on 3 section SFH IV .85 and 1.00 Firing Rates)	550002372	\$65
<b>4100/4125/4145 BECKETT RERATE KIT</b> (Used on 4 section SFH IV 1.00, 1.25, 1.45 Firing Rates)	550002373	\$65
<b>5160/5185 BECKETT RERATE KIT</b> (Used on 5 section SFH IV 1.50 and 1.85 Firing Rates)	550002374	\$65
<b>SFH-3085/3100 BECKETT BURNER IN A BOX KIT</b> (SFH IV 3 section boiler)	550002680	\$815
<b>SFH-4100/4125/4145 BECKETT BURNER IN A BOX KIT</b> (SFH IV 4 section boiler)	550002681	\$855
<b>SFH-5150/5185 BECKETT BURNER IN A BOX KIT</b> (SFH IV 5 section boiler)	550002682	\$869
<b>SFH-6175/6210 BECKETT BURNER IN A BOX KIT</b> (SFH IV 6 section boiler)	550002683	\$885
<b>SFH 3085/3100/4100/4125/4145/5160 RIELLO 40F5 BURNER IN A BOX KIT</b>	550002832	\$1,028
<b>SFH 5160/5185 RIELLO 40F10 BURNER IN A BOX KIT</b>	550002833	\$1,353
<b>SFH 6175/6210 RIELLO 40F10 BURNER IN A BOX KIT</b>	550002834	\$1,364
<b>SFH 3085/3100/4100/4125/4145 CARLIN EZ1-HP BURNER IN A BOX KIT</b>	240010414	\$799
<b>SFH 5160/5185/6175/6210 CARLIN EZ2-HP BURNER IN A BOX KIT</b>	240010415	\$799
<b>STARFIRE SFH-IV SERIES - STANDARD EQUIPMENT</b>		
<p><b><u>STANDARD EQUIPMENT:</u></b></p> <ul style="list-style-type: none"> <li>- Boiler Controls: Primary Control, High Limit and Circulator Control</li> <li>- Heat Exchanger: Cast Iron Heat Exchanger with Cast Iron Push Nipples. Swing out Burner Door.</li> <li>Combustion: Oil Burner, Target Wall/Liner.</li> <li>- Electrical: Wiring Harness, Burner Electrical Disconnect.</li> <li>- Other: Crated Boiler, Flush Jacket, Circulator- 1¼", Supply Tapping-2", Return Tapping-1 1/2", Temperature Pressure Gauge, Safety Relief Valve, Drain Valve.</li> <li>- For Tankless Heater Units add Tankless Hot Water Coil and Triple Combination High Limit/Low Limit/Circulator Control.</li> </ul>		